



GPC16



Serial #: _____



Instruction Manual for the Globe Countertop Pasta Cooker Model GPC16

For Service on Your Pasta Cooker:

1. Visit our website at www.globefoodequip.com
2. Or call the Globe Service Department at 937-299-8625 and ask for contact information for your local service company.

- IMPORTANT SAFETY NOTICE -

This manual contains important safety instructions which must be strictly followed when using this equipment.

Visit our website for information on additional products available from Globe.

www.globefoodequip.com

Slicers, Mixers, Countertop Cooking Equipment, Meat Choppers & Scales

WARRANTY REGISTRATION
SCAN THE QR CODE WITH YOUR MOBILE DEVICE OR GO TO
WWW.GLOBEFOODEQUIP.COM
TO FILL OUT AND SUBMIT YOUR WARRANTY REGISTRATION.

WWW.GLOBEFOODEQUIP.COM/SUPPORT/WARRANTY-REGISTRATION-FORM

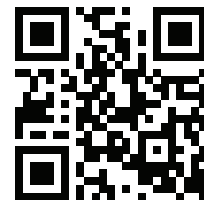

Index

ATTENTION OWNERS AND OPERATORS.....	3
INSTALLATION	4-6
SAFEGUARDS & SAFETY INSTRUCTIONS	7
OPERATING INSTRUCTIONS.....	8-9
CLEANING INSTRUCTIONS	10
TROUBLESHOOTING	11
LIMITED WARRANTY	12



GLOBE FOOD EQUIPMENT COMPANY
2153 DRYDEN RD
DAYTON, OH 45439
PHONE: 937-299-5493
TOLL FREE: 800-347-5423
FAX: 937-299-8623
E-MAIL: info@globefoodequip.com
WEBSITE: www.globefoodequip.com

Attention Owners and Operators

Globe equipment is designed to provide safe and productive processing, cooking and warming of food products as long as the equipment is used in accordance with the instructions in this manual and is properly maintained. Unless the operator is adequately trained and supervised there is a possibility of serious injury. Owners of this equipment bear the responsibility to make certain that this equipment is used properly and safely, to strictly follow all of the instructions contained in this manual, and adhere to the requirements of local, state, or federal law.

Owners should not permit anyone to touch this equipment unless they are over 18 years of age, are adequately trained and supervised, and have read and understood this manual. Owners should also ensure that no customers, visitors or other unauthorized personnel come in contact with this equipment. Please remember that Globe cannot anticipate every circumstance or environment in which its equipment will be operated. It is the responsibility of the owner and the operator to remain alert to any hazards posed by the function of this equipment. If you are ever uncertain about a particular task or the proper method of operating this equipment, ask your supervisor.

This manual contains a number of precautions to follow to help promote safe use of this equipment. Throughout the manual you will see additional warnings to help alert you to potential hazards.

Warnings affecting your personal safety are indicated by:



or



Warnings related to possible damage to the equipment are indicated by:



If the warning labels or this manual are misplaced, damaged, or illegible, or if you require additional copies, please contact your nearest representative or contact Globe directly to request these items at no charge.

Please remember that neither this manual nor the warning label(s) replace the need to be alert, to properly train and supervise operators, and to use common sense when using this equipment.

Installation

UNPACKING

Unpack the pasta cooker immediately after receipt. If the machine is found to be damaged, save the packaging material and contact the carrier within fifteen (15) days of delivery. Immediately contact Globe or your local dealer of the equipment. **You have no recourse to damage after fifteen (15) days.**

⚠️ WARNING

TO AVOID SERIOUS PERSONAL INJURY:

- **ALWAYS** install equipment in a work area with adequate light and space.
- **ONLY** operate on a solid, level, nonskid surface that is nonflammable and away from sinks and water hazards.
- **NEVER** bypass, alter or modify equipment in any way from its original condition. Doing so can create hazards and will void warranty.
- **NEVER** operate pasta cooker without all warnings attached to it.

NOTICE: Local codes regarding installation vary greatly by area. The National Fire Protection Association, Inc, states in its NFPA 96 latest edition that local codes are “authority having jurisdiction” when it comes to requirements for installation of equipment. Therefore, installations must comply with all local codes. Once your pasta cooker has been removed from the packaging, be certain that all protective plastic and residue are removed from all surfaces.

⚠️ WARNING PROPER GROUNDING

THIS MACHINE IS PROVIDED WITH A THREE-PRONG GROUNDING PLUG. THE OUTLET TO WHICH THIS PLUG IS CONNECTED MUST BE PROPERLY GROUNDED. IF THE RECEPTACLE IS NOT THE PROPER GROUNDING TYPE, CONTACT AN ELECTRICIAN. DO NOT, UNDER ANY CIRCUMSTANCES, CUT OR REMOVE THE THIRD GROUND PRONG FROM THE POWER CORD OR USE ADAPTER PLUG.



Fig. 4-1 Correct



Fig. 4-2 Incorrect

1. Complete the warranty registration online at www.globefoodequip.com/support/warranty-registration-form.
2. Pasta cooker outside covering/containment unit, water and baskets will be HOT during and after use. Use caution when approaching the unit.

Electrical

The Pasta Cooker is a 208/240V boiler wired to use a 6-20R receptacle. This unit requires 14.2/15.8 amps to produce between 2900/3800 watts and must be used on a dedicated circuit.

The installation of the pasta cooker must conform to the NATIONAL ELECTRIC CODE AND ALL LOCAL ELECTRIC CODES AND ORDINANCES AND ALL LOCAL ELECTRICAL COMPANY RULES AND REGULATIONS. APPROVED FIRE SAFETY AND HOOD SYSTEMS MUST BE INSTALLED ACCORDING TO NFPA 96 STANDARDS.

Installation

ASSEMBLY AND INSTALLATION OF THE PASTA COOKER

1. Read this manual thoroughly before installation and operation. DO NOT proceed with installation and operation if you have questions or do not understand everything in this manual. Contact your local representative or Globe first.
2. Remove the parts that make up the pasta cooker from the box. Once the unit has been removed from the packaging, be certain that all protective plastic and residue is removed from all surfaces.
3. Inspect the unit to make sure all parts have been provided. (Pasta cooker body and attached cooking pan, element/control head, cooking element, baskets, attached drain valve and adjustable feet).
4. Select a location for placement of pasta cooker which has a level, solid, nonskid surface that is nonflammable, away from water hazards or sinks, and is in a well-lighted work area away from visitors.
5. Install the unit in a location with at least 6" between the appliance and walls or other objects.
6. Proper connection and power supply are necessary for satisfactory performance. (Do not plug the unit in yet).
7. Make sure that the pasta cooker is installed in a well ventilated area.
8. Make sure to put pasta cooker in an area that is open and not underneath a cabinet or other overhang other than a vent hood.



WARNING Pasta cooker, water, and contents get EXTREMELY HOT. Make sure all flammable/combustible materials are set away from this equipment.

Feet

Install four feet by screwing each foot into the threaded openings on bottom corners of the unit. Failure to use feet will void warranty and could cause unsafe conditions.

Leveling

Level unit by adjusting the four feet and tighten securely. Check on feet regularly to make sure they are tight. Make sure the work surface of the bench/table that pasta cooker sits on is kept clean and is maintained to avoid any accidents. Make sure the bench/table is sufficient to hold the weight of the unit. Pasta Cooker weight (empty) = 9 lbs. and about 41.2 lbs. with water. (This weight can vary slightly depending on the water level, basket type and food added.)

COMMISSIONING:

Commissioning of the new pasta cooker is of the utmost importance. Commissioning is the thorough and methodical testing of the equipment, sub systems, and systems to make sure that the final product functions correctly and safely at the work site. By identifying any potential problems (i.e. equipment location, ventilation, local fire/electrical codes, installation, operator training and certification) prior to equipment being placed into service, costly outages and potential damages can be avoided.

SAFETY ALWAYS.

Installation

IMPORTANT:

Use only the baskets provided and the pot attached to the unit. DO NOT replace the baskets or attempt to replace the pot with other containers.

The pasta cooker electrical head has two locating buttons that need to be aligned to operate.

1. Lower the element into pot by following the two simple steps (Fig. 6-1 and Fig. 6-2). Point A cradles and guides the head to unit's body.

NOTE: Push buttons are located on the operator right-side to lock and unlock; lift and lower heating element for cooking or cleaning. Point A is the cradle pin guide. Point B determines the position of the head in either the working (Drip) position or cleaning position (Access Pot position) (Fig 6-3).

2. Put control head into supporting cradle brackets. Put Point A into element cradle pin guide, then gently push the electrical head forward to lock Point B into first position.
3. Use Point B to keep control head in the raised (Drip or Access Pot) position. To lower element into pan and operating position, hold insulated element handle and push and/or depress button.

These steps can be repeated in reverse for cleaning purposes.

NOTE: Point B has two level options: Fully raised 90° (Access Pot position) allows pot to be accessed for cleaning; raised to 75° (Drip position) allows for cleaning and draining water from element.

4. Make sure pasta cooker is "Off". It is now ready to be filled with the appropriate amount of water.

NOTE: In the "Off" position, the pot can be filled with the heating element up or down. Once the pot is full with appropriate amount of water, carefully lower the heating element into the pot if heating element is in up position. Make sure the element is always submerged. Once the element is submerged, pasta cooker can be plugged in and can be turned "On". See Operating Instruction section in manual to correctly start and operate pasta cooker.

IMPORTANT: Continually observe and maintain water level in boiling pan. Water level will decrease with each boil.

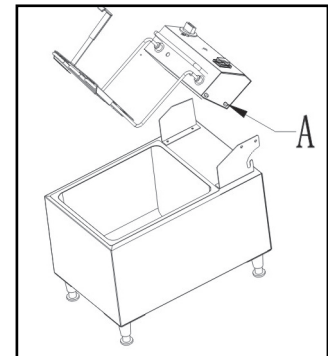

Fig. 6-1

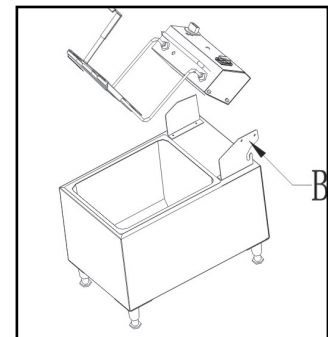

Fig. 6-2

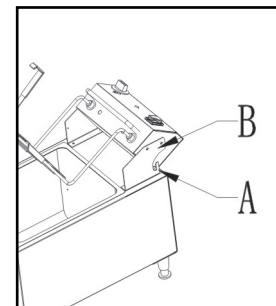

Fig. 6-3

Safeguards & Safety Instructions

When using electrical appliances, basic safety precautions should always be followed. Follow all safeguards and safety instructions including, but not limited to, the following:

TO AVOID SERIOUS PERSONAL INJURY: Do not attempt to fry with this unit. This unit is not a fryer.

WARNING

During and after operation pasta cooker reaches very high temperatures. The water, water pot, and all surfaces will be **EXTREMELY HOT**. Take extreme caution when operating. Let water and pasta cooker cool before handling water or equipment.



- **DO NOT** operate pasta cooker before reading the instruction manual.
- **DO NOT** touch pasta cooker or water during or after cooking. All parts become **EXTREMELY HOT**.
- **ALWAYS** disconnect or unplug electrical power before cleaning, servicing or adjusting parts or attachments.
- **NEVER** bypass, alter, modify or attach unauthorized parts to equipment. Doing so can create hazards and will void warranty.
- **NEVER** operate unit with a damaged power cord or plug.
- **NEVER** leave pasta cooker on overnight or for prolonged periods of non-use.
- **NEVER** use pasta cooker as a heating source for your kitchen, space, or room.
- **ALWAYS** keep hands, hair and clothing away from heating elements.
- **NEVER** handle unit, pan or water during or directly after use. **ALWAYS** allow unit and water to cool completely before handling equipment.
- **DO NOT** overload pasta cooker with water or food product. Water will splatter causing serious injuries and burns.
- **DO NOT** pull/yank on cord to disconnect. Turn off all controls, then gently remove plug from wall outlet.
- Before handling and cleaning – Switch “Off” the power and disconnect from the main power. Unit must be unplugged and cool to touch. Allow time for water to cool completely. Unit will be too hot to handle immediately after use.

WARNING

When using electrical appliances, basic safety precautions must always be followed. **DO NOT** operate pasta cooker if unit appears damaged or malfunctions in any manner. Call Globe Customer Service for assistance.



- Close supervision is necessary when pasta cooker is being used. Operator must be properly trained on all operational and safety procedures, especially when using near others.
- To protect against electrical shock, do not immerse cord, plugs or appliance in water, liquid or dishwasher.
- Unplug unit when not in use and before cleaning. Allow unit and water to cool before moving or cleaning.
- Use of accessories or cooking pans that are not recommended by the manufacturer, can cause fire and/or injury.
- **DO NOT** use outdoors. For indoor use only.
- Do not allow power cord to hang over edge of table or counter, or to touch hot surfaces.
- Do not place pasta cooker in, on or near open flames, electric burners, heated ovens or other high temperature equipment or surroundings.
- Do not use pasta cooker for anything other than boiling water for cooking. Use with provided basket(s) and supervision.
- Do **NOT** pull/yank on cord to disconnect.
- Globe takes care to make sure that all products are safe. Steel cutting procedures used to manufacture these items result in sharp edges. Take care when in contact with pasta cooker.
- Continually observe and maintain water level in boiling pan. Water level will decrease with each boil.
- **ALWAYS BE PREPARED** in case of a fire, make sure to have the correctly rated fire extinguisher nearby.
- **DO NOT** immerse pasta cooker in water, as this will cause permanent damage to unit.

The pasta cooker **does not** contain **any** user-serviceable parts. Globe dealers or recommended qualified technicians must carry out repairs. Do not remove components or service panels on this product.

Operating Instructions

OPERATING PASTA COOKER

Always make sure all parts are cleaned thoroughly before use. Detergent can be used to break down cooking residue and make sure adequate cleaning. For cleaning instructions, refer to Cleaning Instructions section of this manual.

NOTE: Always preheat and bring water to a boil before adding food product.

Once pasta cooker has been correctly positioned in the work space, it is ready for use.

1. Make sure that unit is “Off”. The temperature dial must be positioned “Off” and power rocker switch must be in “Off” position (**O** = Off and **|** = On).
2. Plug unit in. Unit now has electric current flowing to it.
3. Check to make sure drain tap on front of unit is in the closed and locked position. (The handle must be turned, locked and hanging to the left of drain.)
4. Fill pot with water until it reaches level indicator line. Make sure to fill water above “Min” line, but not above “Max” line. (Approximately 2.1 gallons/8 liters.)

CAUTION

- Do not operate this unit without water.
- Use only water (**no** oil, shortening, etc) in this unit.
- Do NOT raise the heating element while the unit is in use.



5. Turn power switch to “On” position (**|**). The timer display will illuminate, unit will beep and switch will illuminate indicating there is power.
6. Turn/adjust thermostat dial “On” by setting it to the desired temperature. The heat indicator light, located in the upper right of the control head, will illuminate indicating that unit is heating.
7. Allow the water to reach the set temperature. Whenever the water is being heated, heat indicator light will be illuminated. When the water has reached the required temperature, the red light will switch off. As the water temperature fluctuates, the thermostat will operate to maintain the set temperature.

NOTE: Temperature for cooking pasta and other particular food types will vary. Cook according to individual requirements.

8. Once the water has reached the desired temperature, add pasta/food product and basket(s) to the water.

WARNING

- Be cautious of boiling water. Boiling water will scald skin and cause severe burns.
- DO NOT overload the pasta cooker with water or food product. Water will splatter causing serious injuries and burns.
- Use caution when adding pasta into the baskets. The water is EXTREMELY HOT!
- Always use extreme caution when lowering, lifting, and draining baskets.
- Do NOT attempt to remove inner pot.
- After water has cooled completely, use the drain valve to empty water from inner pot.



TIMER OPERATION:

Digital timer has four programmable times to make sure products are cooked consistently. Each program time is adjustable from 1 second to 15 minutes.

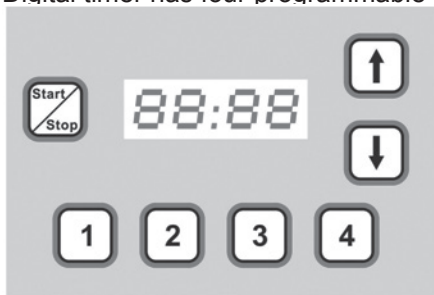

Introduction of buttons.

1. Start/Stop - Start and stop time/countdown
2. 1, 2, 3 & 4 - Program buttons, for time setup selection
3. ▲ adjust time upward
4. ▼ adjust time downward

Operating Instructions

TIMER FUNCTION MODE

START/STOP:

Once a timer button has been selected, push the Start/Stop button. Start begins the timer count down.

To stop or pause timer, press Start/Stop button a second time. Display will blink once every second.

To continue timer, press Start/Stop button again to release it from paused/stopped function. The timer will begin to count down the selected programmed time to 0. Once timer has timed out, display will blink 00:00 and unit will beep five times.

To stop timer blinking 00:00, repeat the last selected time by pressing Start/Stop button one time OR select 1, 2, 3 or 4 to select a new preset time.

Select Start/Stop to begin timer again.

Program time setup buttons:

1. Select one of the program buttons, 1, 2, 3, or 4, once.
2. Display will show the Factory default value.

MENU	1	2	3	4
Factory default	00: 30	01: 00	01: 30	02: 00
Adjustable time	0: 01-15: 00	0: 01-15: 00	0: 01-15: 00	0: 01-15: 00

3. Select a preset and then press Start/Stop button to begin timing the boil to selected time/preset .

NOTE: Once a program button has been selected and it begins countdown, all other buttons are inoperable except Start/Stop button. Select Start/Stop button to pause/stop timer as needed.

If time needs to be added or a new time selected, press Start/Stop button to stop or pause timer, then press 1, 2, 3, or 4, to reset your time. Next, press Start/Stop button to continue cooking time.

RESET 1, 2, 3, OR 4 PRESET TIME:

To reset/adjust a preset time up or downward:

1. Make sure pasta cooker is on. If needed, use Start/Stop button to stop all functions.
2. Press one of the program buttons (1, 2, 3, or 4) one time.
3. Display will show preset time.
4. Press desired program button a second time. Display will begin to blink
5. Press ▲ or ▼ arrow button to the desired time. (Time accumulates by 5 seconds each time the ▲ or ▼ button is pressed).
6. After 3 seconds of inactivity, timer will be set with the entered time.

Once time has expired or proper cooking time has elapsed, carefully lift baskets out of water and hold them over pot to drain water from pasta before serving.

NOTE: If unit stops working or display is blank (not showing anything) press any button to display 00:00.

IMPORTANT: Continually monitor and maintain water level in boiling pan. Water level will decrease with each boil.

NOTE: In higher elevations above sea level, evaporation occurs more quickly.

Cleaning Instructions

WARNING

WARNING: Addition to warnings listed below, refer to all Safeguards and Safety Instructions section of this manual.

- **ALWAYS** unplug pasta cooker and allow water to cool before draining water from drain valve.
- **DO NOT** use cleaning fluids that can be harmful to you, others around you, or to the environment.
- **DO NOT** hose down, immerse or pressure wash any part of pasta cooker.
- **NEVER** use a scrubber pad, steel wool or abrasive material to clean pasta cooker.



ALWAYS DISCONNECT OR UNPLUG ELECTRICAL POWER FROM PASTA COOKER BEFORE CLEANING.

RECOMMENDED CLEANING

Cleaning & Maintenance

CAUTION

Pasta cooker was designed for easy disassembly and cleaning. Pasta cooker must be cleaned after each day's operation; however, it can require cleaning more often depending on the volume of production. A clean boiler performs better and more safely, produces higher quality product and reduces maintenance costs. When cleaning, always consider safety first. Make sure all power is off and unit has been disconnected from power source.

WARNING

Allow pasta cooker and water to completely cool before draining water from drain valve.

1. Turn thermostat to "Off" position, switch pasta cooker to "Off" position and disconnect from power source.
2. Allow water to cool to a safe handling temperature.
3. Remove baskets and clean them, using standard dish-washing detergent. Be sure to rinse basket(s) thoroughly.
4. Using the handle on the element assembly, raise the heating element to the first stop position.
5. With a bucket placed securely under the drain trap, lift and rotate the valve handle counterclockwise, allowing the drain to open and the water to flow freely from the pot into the bucket.
6. Once the water has been completely drained from the unit, raise the heating element to the second raised stop position, fully raising the element and electric control head. Be sure that the latch has properly engaged.
7. Thoroughly clean and rinse the pot. Wipe/clean the pasta cooker body.
8. For detail cleaning, the electrical control head can be entirely removed from the boiler body.
9. During cleaning take care to avoid damage to the element or the switch on the electrical control head.

NOTE: The baskets are dish machine washable or they can be submerged in water for cleaning. Make sure baskets are dried fully before reassembling. The pasta cooker pan that holds the water is not designed to disassemble from the pasta cooker body.



- Check the power cord for damage.
- For assistance with disassembly or reassembly of the pasta cooker during or after cleaning, refer to the Installation section of this manual.

CAUTION

NEVER submerge or run water over the unit.

An Authorized Servicer must perform servicing.

Troubleshooting

ISSUE	CAUSE	SOLUTION
Pasta cooker not working	Power supply	Check power source
	Power switch has not been turned on	Check that the pasta cooker is correctly plugged in and turned on.
	Plug/cord damaged	Call for service
	Internal wiring fault	Call for service
	Food debris stuck on or between heating element	Power off boiler, let the pasta cooker cool and then clean on or around elements removing food debris.
	Thermostat dial has not been set	Set the thermostat dial to the desired temperature setting.
	Thermal cut off has activated	Power off pasta cooker, let unit cool. Clean on and around elements, removing food debris. Unscrew small, black cap on the back of the control head exposing the reset button. Press button to reset. Re-cap the reset button and start the unit normally. Call for service if problem continues or if the pasta cooker will not reset.
Water is not heating up and indicator light is On	Thermostat or heating element has failed	Call for service
Indicator light is Off but pasta cooker is operating normally	Faulty indicator light	Call for service

If problem persists and the above solutions do not correct the issue, please call Globe's Service Department at: 866-260-0522.

Limited Warranty

Globe Food Equipment Company (“GFE”) warrants to the original purchaser of new equipment that said equipment, when installed in accordance with our instructions within North America and subjected to normal use, is free from defects in material or workmanship for a period of one (1) year (excludes wear items). The labor warranty is one year from original installation date or factory shipment date (not to exceed 18 months) whichever occurs first. Unit must be sent prepaid to GFE for repair. No mileage or travel time is paid.

THIS WARRANTY IS IN LIEU OF ALL OTHER WARRANTIES, WHETHER EXPRESSED OR IMPLIED. GFE EXPRESSLY DISCLAIMS ANY IMPLIED WARRANTY OF MERCHANTABILITY OR EXPRESSED OR IMPLIED WARRANTY OF FITNESS FOR A PARTICULAR PURPOSE.

GFE’S OBLIGATION AND LIABILITY UNDER THIS WARRANTY IS EXPRESSLY LIMITED TO REPAIRING EQUIPMENT WHICH PROVES TO BE DEFECTIVE IN MATERIAL OR WORKMANSHIP WITHIN THE APPLICABLE WARRANTY PERIOD. All repairs pursuant to this Warranty will be performed by GFE Service during normal working hours. IN NO EVENT SHALL GFE BE LIABLE FOR INCIDENTAL OR CONSEQUENTIAL DAMAGES TO BUYER OR ANY THIRD PARTY, INCLUDING, WITHOUT LIMITATION, LOSS OF PROPERTY, PERSONAL INJURY, LOSS OF BUSINESS OR PROFITS OR OTHER ECONOMIC LOSSES, OR STATUTORY OR EXEMPLARY DAMAGES, WHETHER IN NEGLIGENCE, WARRANTY, STRICT LIABILITY, OR OTHERWISE.

This warranty is given only to the first purchaser from a retail dealer. No warranty is given to subsequent transferees.

This warranty does not cover product failures caused by: failure to maintain, neglect, abuse, damage due to excess water, fire, normal wear, improper set up and use. Periodic maintenance is not covered.

This warranty is not in force until such time as a properly completed, digitally signed and Installation/Warranty Registration has been received by GFE within 30 days from the date of installation. Complete the online warranty registration at: www.globesfoodequip.com/support/warranty-registration.form.

Proof of purchase is required if extended more than one (1) year from date of shipment from the factory

THE FOREGOING WARRANTY PROVISIONS ARE A COMPLETE AND EXCLUSIVE STATEMENT BETWEEN THE BUYER AND SELLER. GFE NEITHER ASSUMES NOR AUTHORIZES ANY PERSONS TO ASSUME FOR IT ANY OTHER OBLIGATION OR LIABILITY IN CONNECTION WITH SAID EQUIPMENT.

Example of items not covered under warranty, but not limited to just these items:

1. Acts of God, fire, water damage, burglary, accident, theft.
2. Freight damage.
3. Improper installation or alteration of equipment.
4. Use of generic or after market parts.
5. Repairs made by anyone other than a GFE designated servicer.
6. Lubrication.
7. Expendable wear parts, adjustable feet, blown fuses, lamps, etc.
8. Cleaning of equipment.
9. Misuse or abuse.

WARRANTY REGISTRATION
SCAN THE QR CODE WITH YOUR MOBILE DEVICE OR GO TO
WWW.GLOBESFOODEQUIP.COM
TO FILL OUT AND SUBMIT YOUR WARRANTY REGISTRATION.

www.globesfoodequip.com/support/warranty-registration.form

