

Parts Catalog



PF10E/PF10E-C

Electric Fryer

Model: **PF10E/PF10E-C**

02/08/2022 Rev -
IMPORTANT!

TO EXPEDITE SHIPMENT OF PARTS, ALWAYS SPECIFY MODEL, REV,
PART NUMBER, AND SERIAL NUMBER OF UNIT.

GLOBE FOOD EQUIPMENT COMPANY

2215 East River Road
Dayton, Ohio 45439

Parts Department

Toll Free 1-800-745-6238 · Fax (937) 290-0585

E-Mail: info@globefoodequip.com

Website: www.globefoodequip.com

Not for resale

Table of Contents

Description

Page

PF10E_PF10E-C Electric Fryer

4

[PF10E](#), [PF10E-C](#) Wiring Diagram

6



PF10E PF10E-C Electric Fryer

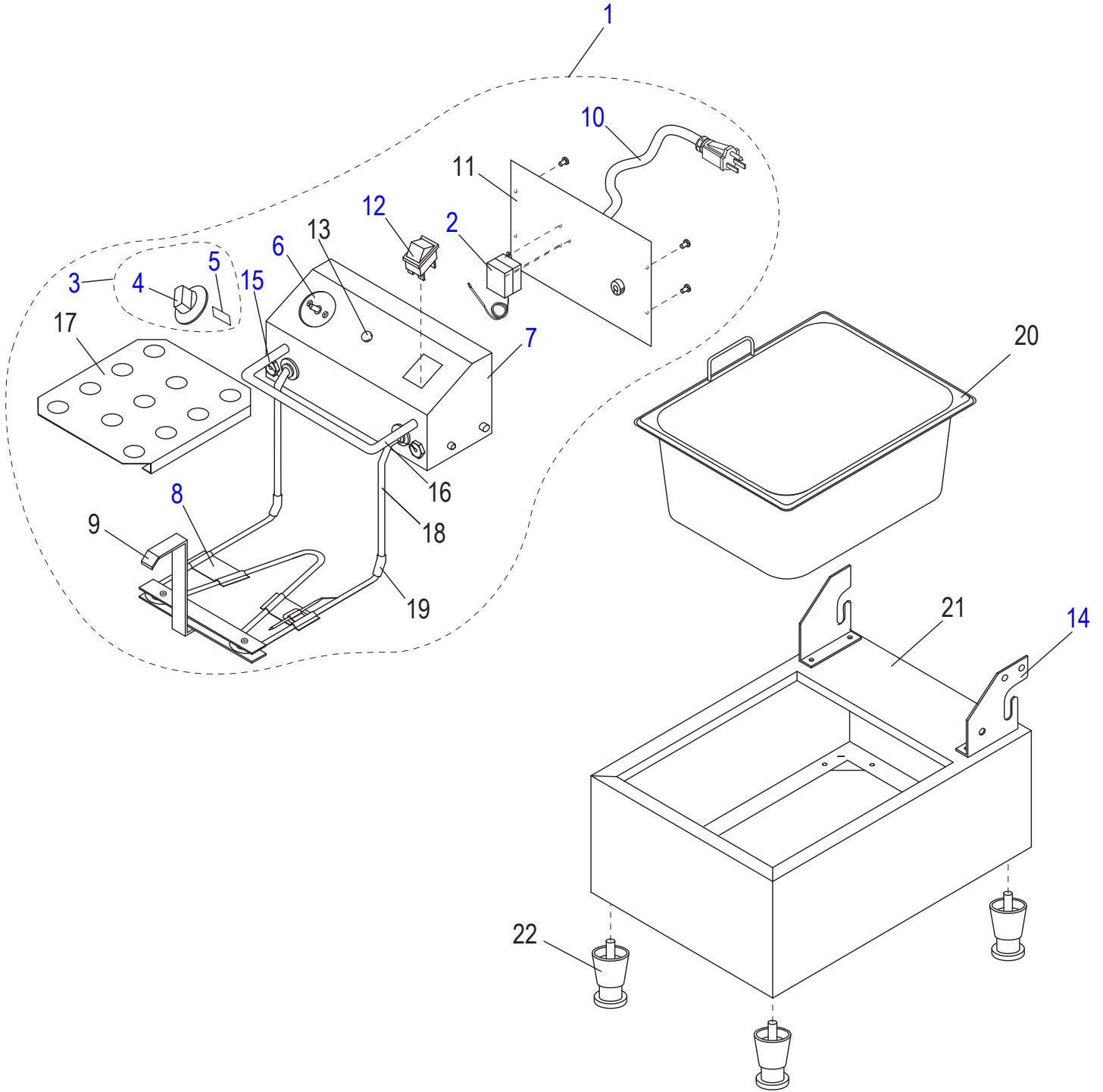



PF10E PF10E-C Electric Fryer

Item	Part Number	Description	Qty	Serial Number
1	U06051470590	Control Box Assembly (Back Hook)	1	
1	U06051471098	Control Box Assembly (Front Hook)	1	PF10E0001496 ->
2	U00577	Thermal Cut Out	1	
3	U01033	Knob Assembly	1	
4		Dial	1	
5		Spring Plate	1	
6	U03051220008	Thermostat	1	
7		Control Enclosure	1	
8	U01051025402	Tube Clamp (Left)	1	
8	U00766	Tube Clamp (Right)	1	
9	U06051470011	Element Hook	1	
10	U03021205012	Cord and Plug, 120V	1	
10	U03021205010	Cord and Plug (For Model -C)	1	
11		Back Cover Plate	1	
12	U03041215027	Power Switch	1	
13	U03091240005	Indicator Light, 120V	1	
14	U00765	Flange Assembly (Right)	1	
14	U01051025556	Flange Assembly (Left)	1	
15	U02121165001	Stuffing Nut	2	
16		Basket Hook	1	
17	U01051025555	Element Cover	1	
18	U03061225044	Heating Element	1	
19	U01051025128	Tube Bend Clamp	2	
20	U01121063013	Pan (No Handles)	1	Used w/ Back Hook Baskets
20	U01121063043	Pan (Retractable Handles)	1	Used w/ Front Hook Baskets
21		Fryer Cabinet	1	
22	U01021005002	Foot	4	
23	U02053	Overlay	1	(Not Shown)
24	U02043	Wiring Kit	1	(Not Shown)



PF10E Wiring Diagram

