

# Parts Catalog



**PF16E**

## Electric Fryer

**Model: PF16E**

03/22/2019 Rev A

IMPORTANT!

TO EXPEDITE SHIPMENT OF PARTS, ALWAYS SPECIFY MODEL, REV,  
PART NUMBER, AND SERIAL NUMBER OF UNIT.

## **GLOBE FOOD EQUIPMENT COMPANY**

2215 East River Road  
Dayton, Ohio 45439

### **Parts Department**

Toll Free 1-800-745-6238 · Fax (937) 290-0585

E-Mail: [info@globefoodequip.com](mailto:info@globefoodequip.com)

Website: [www.globefoodequip.com](http://www.globefoodequip.com)

Not for resale



# Table of Contents

**Description**

**Page**

PF16E Electric Fryer

4

PF16E Wiring Diagram

6



# PF16E Electric Fryer

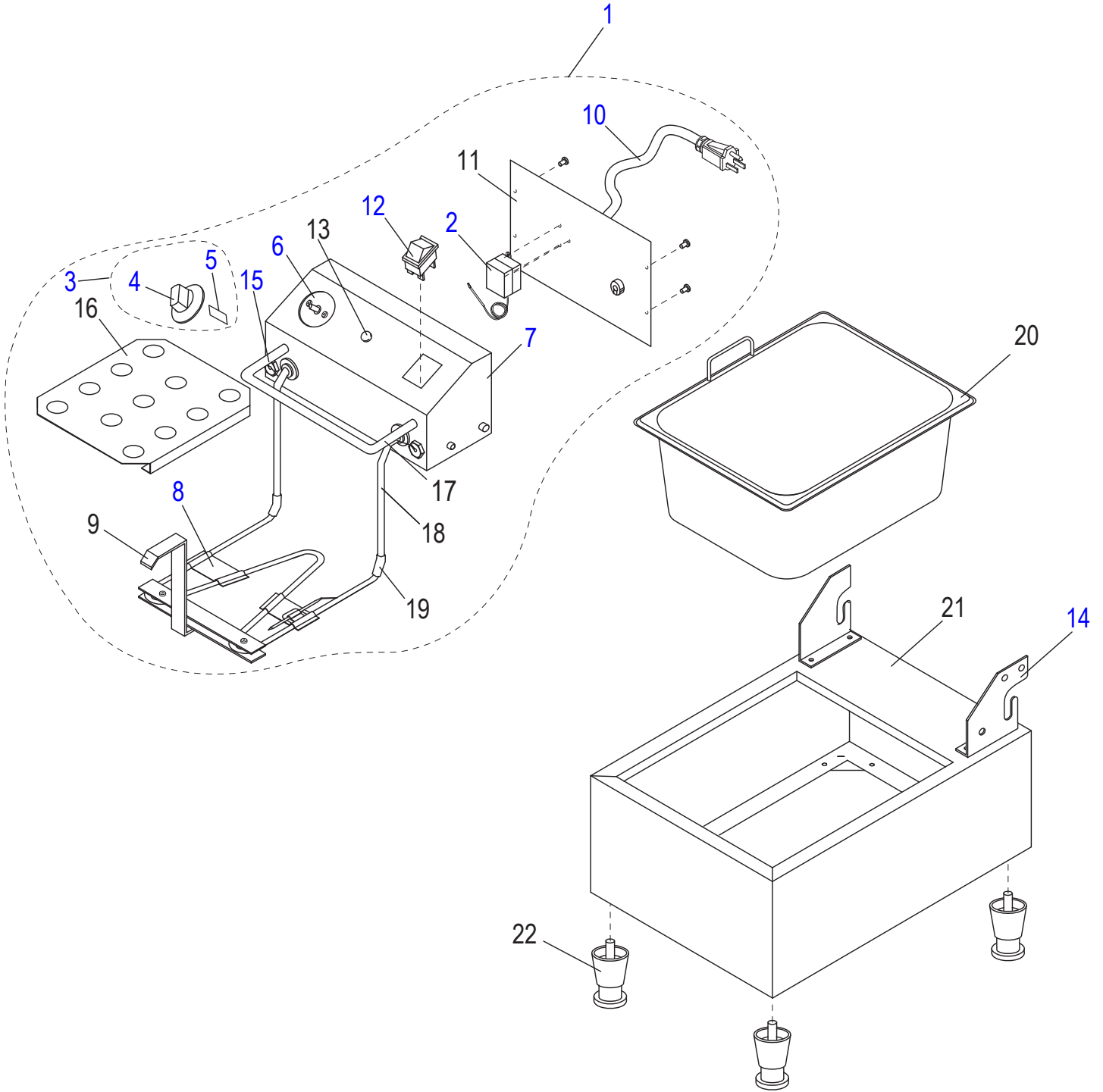



## PF16E Electric Fryer

Item	Part Number	Description	Qty	Serial Number
1	U06051470593	Control Box Assembly (Back Hook)	1	
1	U06051471101	Control Box Assembly (Front Hook)	1	PF16E00011111 ->
2	U00577	Thermal Cut Out	1	
4		Dial	1	
3	U01033	Knob Assembly	1	
5		Spring Plate	1	
6	U03051220008	Thermostat	1	
7		Control Enclosure	1	
8	U01051025117	Tube Clamp	2	
9	U00584	Element Handle Assembly	1	
10	U03021205013	Power Cord and Plug	1	
11		Back Cover Plate	1	
12	U03041215027	Power Switch	1	
13	U03091240006	Indicator Light	1	
14	U01051025556	Flange Assembly (Left)	1	
14	U00765	Flange Assembly (Right)	1	
15	U02121165001	Stuffing Nut	2	
16	U01051025555	Element Cover	1	
17		Basket Hook	1	
18	U03061225047	Heating Element	1	
19	U01051025128	Tube Bend Clamp	2	
20	U01121063016	Pan (Retractable Handles)	1	Used w/Back Hook Baskets
20	U01121063044	Pan (Retractable Handles)	1	Used w/Front Hook Baskets
20	U06051471081	Pan (Fixed Handles)	1	Used w/Front Hook Baskets
21		Fryer Cabinet	1	
22	U01021005002	Foot	4	
23	U02053	Overlay	1	(Not Shown)
24	U02043	Wiring Kit	1	(Not Shown)



# PF16E Wiring Diagram

