

Parts Catalog



ELECTRIC CONVEYOR TOASTER

MODEL: TC1

02May2011

IMPORTANT!

TO EXPEDITE SHIPMENT OF PARTS, ALWAYS SPECIFY MODEL, REV,
PART NUMBER, AND SERIAL NUMBER OF SLICER.

GLOBE FOOD EQUIPMENT COMPANY

2215 East River Road

Dayton, Ohio 45439

Parts Department

Toll Free 1-800-745-6238 · Fax (937) 290-0585

E-Mail: globeinfo@globeslicers.com

Website: www.globeslicers.com

Not for resale

TC1 CONVEYOR TOASTER COMPONENTS

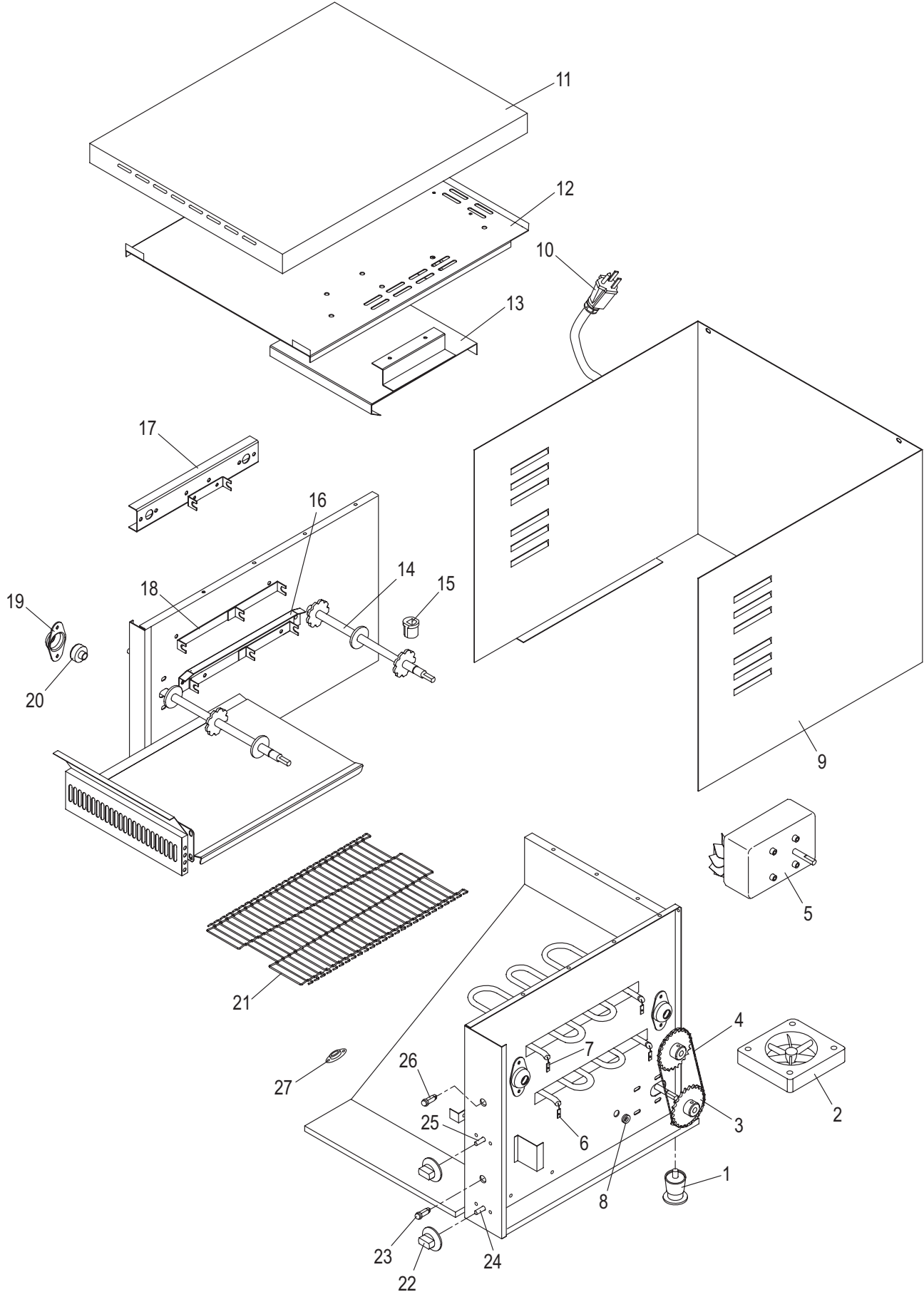

TC1 CONVEYOR TOASTER PARTS LIST

Item	Description	Part Numbers	Qty
1	Foot	U01021005002	4
2	Fan	U03991290033	1
3	Gear, 12 Tooth	U01021005059	1
3A	Gear, 20 Tooth	U01021005037	1
4	Chain	U01021005147	1
5	Motor	U03011200001	1
6	Lower Element	U03061225029	1
7	Upper Element	U03061225030	1
8	Wireway Bushing	-	1
9	Toaster Enclosure	-	1
10	Power Cord and Plug	U03021205011	1
11	Top Cover	-	1
12	Top Panel, Inner	-	1
13	Element Cover	-	1
14	Conveyor Drive Shaft	U01141065004	2
15	Bushing	U02101155021	1
16	Conveyor Support Runner	-	2
17	Element Assembly Plate	-	2
18	Element Fixing Plate	-	4
19	Shaft Bracket	U01051025053	4
20	Shaft Cover	U02991190003	4
21	Conveyor Belt	U01021005004	1
22	Knob	U02101155013	2
23	Power Indicator Light (Green)	U03091240004	1
24	Multi Function Control Switch	U03041215009	1
25	Variable Speed Controller	U03991290015	1
26	Malfunction Indicator Light (Red)	U03091240006	1
27	Thermal Cut-Out	U03051220001	1

WIRING DIAGRAM, TC1

