



100 Series Coffee Grinders

Models 100 and 190SS



Model 100



Model 190SS



Table of Contents

Specifications.....2	Cleaning & Maintenance.....6
Safety Information.....2	Troubleshooting Guide.....7
Installation.....3	Parts Diagram and List8
Operation3	Wiring Diagram.....10

Thank you for purchasing this quality coffee grinder. For your safety and the safety of others, read all warnings and the operator's manual before installing or using the product. Properly instruct all operators. Keep training records. For future reference, record serial number here:

Grindmaster-Cecilware

4003 Collins Lane, Louisville, KY 40245 USA
Phone: 502.425.4776 Toll Free: 800.695.4500
Fax: 502.425.4664
Web: gmcw.com Email: info@gmcw.com

Grindmaster-Cecilware provides the industry's BEST warranty. Visit gmcw.com for warranty terms and conditions.



Specifications

Model	Description	Electrical
100	Single portion grinder, (1) 6 lbs. hopper C-UL US Certification	120V / 920 W / 8A / 1 Ph
190SS	Single portion grinder, (1) 6 lbs. hopper UL Certification	120V / 920 W / 8A / 1 Ph
190E-SSG	Single portion grinder, (1) 6 lbs. hopper UL, NSF Certification	230V / 50/60 Hz / 4A

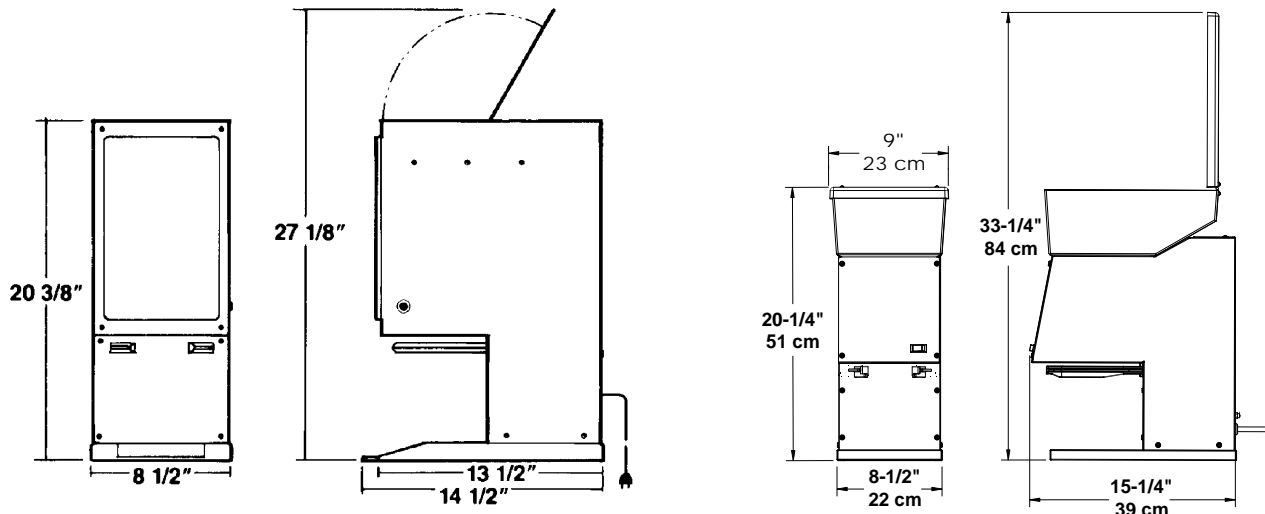

Model 100

Model 190SS

Safety Information

Important Safety Information



This is the safety alert symbol. It is used to alert you to potential personal injury hazards. Obey all safety messages that follow this symbol to avoid possible injury or death.

For your safety and the safety of others, read all warnings and the operator's manual before installing or using the product.

DANGER: This term warns the user of imminent hazard that will result in serious injury or death.

WARNING: This term refers to a potential hazard or unsafe practice, which could result in serious injury or death.

CAUTION: This term refers to a potential hazard or unsafe practice, which could result in minor or moderate injury.

NOTICE: This term refers to information that needs special attention or must be fully understood.

WARNING

- Product must be attached to a three wire 120V 15 AMP receptacle (export units - 230V 16 AMP).
- Do not deform plug or cord.
- Follow national and local electrical codes.
- Do not use near combustibles.
- Use only on a circuit load that is properly protected and capable of the rated load.
- Always unplug unit from power supply before servicing or cleaning.

FAILURE TO COMPLY RISKS PERSONAL INJURY, SHOCK HAZARD, FIRE, OR DAMAGE TO EQUIPMENT.

Safety Information (continued)

CAUTION

Personal injury hazard. Keep fingers, hands, and foreign objects out of hopper or chute opening.

NOTICE

Never connect to an overloaded circuit or to an extension cord, otherwise serious damage to the motor may result.

Installation

NOTICE: It is essential that full voltage and amperage always be available as it takes full power to grind coffee.

Please read this manual before operating the grinder.

1. Carefully remove grinder from carton.
2. Place grinder in position on shelf, counter or other flat surface.
3. Plug grinder into the specified power source. (Check rating plate on back of unit for voltage and amperage requirements.) Do not use an extension cord.
4. Grind a small amount of whole bean coffee following operating instructions as described in this manual.

If you need help, call Grindmaster-Cecilware Technical Service Department for help, (502) 425-4776 or (800) 695-4500 (USA & Canada only) 8 AM - 6 PM EST.

Prior authorization must be obtained from Grindmaster-Cecilware for all warranty claims.

Operation

Your new coffee grinder is easy to operate and maintain. Before you place it in service, please have all personnel familiarize themselves with these instructions. Keep this manual in a convenient place for ready reference.

How to Operate

1. Fill the hopper with whole bean coffee and close the lid.
2. Place the brew basket with coffee filter between brew rails.
3. Push the start button. Grinder will grind a predetermined amount of coffee, and then automatically shut off.
4. When grinder stops, remove the brew basket.

NOTE: If too much or too little coffee is dispensed, adjust the timer inside the grinder to dispense the desired weight of ground coffee (see **Portion Adjustment**). The grinder is factory set to deliver approximately 2 ounces of ground coffee. This weight is approximate, as the density of all coffee beans is not

the same. The only way to ensure the desired portion is being dispensed is to weigh the coffee after it has been ground.

NOTE: The grind is factory set to deliver a standard autodrip grind. The grind texture can be adjusted, if necessary, to a finer or coarser grind (see **Grind Adjustment**).

Helpful Hint

Because of the inherent properties of some decaffeinated coffee, it may be necessary to dispense a slightly greater amount to achieve the desired level of flavor extraction as in regular coffee. This should be evaluated based on the coffee you use as well as the brewing equipment used.

Portion Adjustment

This unit utilizes a dual range solid state timer control to determine the amount of beans ground during each grind cycle. Changing the timer setting will increase or decrease the amount of ground coffee dispensed.

The length of time to grind a specified quantity of coffee is dependent upon the grind setting and the hardness and size of the coffee beans. The **Approximate Dial Setting Table** can be used as a guide. The final setting will have to be determined by weighing the coffee dispensed. Once the time has been established, the grinder will dispense approximately the same quantity of coffee each time the start button is pushed. To adjust the portion see **Timer Adjustment**.

Operation (continued)

Approximate* Timer Dial Setting for Auto Drip Grind

120V and 230V Models 100 & 190SS Series			
Switch Up (0.75-15 sec)		Switch Down (3-60 sec)	
Inside dial		Outside Dial	
Amount Desired (oz.)	Time Setting (seconds)	Amount Desired (oz.)	Time Setting (seconds)
0.5	1	6	15
1	3	8	20
1.5	4	10	25
2	5	12	29
2.5	6	14	34
3	7	16	39
3.5	8	18	43
4	10	20	48
5	12	25	60

*You should check the weight of the coffee dispensed to guarantee the time setting is delivering the amount desired. Minor adjustments may be necessary. Different roasts and blends of coffee may affect the time required to obtain a desired throw weight.

Timer Adjustment

Range Switches [Equipped on timers 86456 (110V) & 86450 (230V)]

The timer dial can be set from 0.75 to 60 seconds by using the range switch located to the left of the dial. The range selection allows more precise time settings from the dial for different throw weights.

Switch Up

Time: 0.75 to 15 seconds (refer to the inner ring of numbers around dial)

Throw Weights: 1/2 oz. to 6 oz. of coffee

Switch Down

Time: 3 to 60 seconds (refer to the outer ring of numbers around dial)

Throw Weights: 1.5 oz. to 27 oz. of coffee

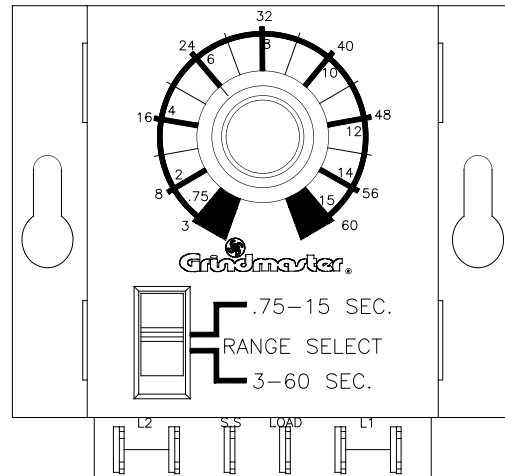

Setting the Timer:

Tools required: Phillips screwdriver

⚠ WARNING Unplug grinder to prevent electrical shock.

1. Model 100: Remove lower cover plate (4 screws).
2. Model 190SS: First remove the (2) screws in the timer cover behind the hopper. Now remove the panel to access the timer.
3. Refer to the **Approximate Timer Dial Setting Chart** to determine the proper time setting for the amount of coffee you wish to dispense.
4. Set the range switch to the proper position as determined by the time required for your desired portion.
5. Now set the timer dial. Be sure to use the ring of numbers that correspond to the range you have selected.
6. Check the weight of coffee dispensed to guarantee the dial setting is delivering the approximate amount desired. Minor adjustments may be required.
7. Once time is set, replace the cover plate or access panel. Plug unit in.

Grinds

Before shipment, this grinder has been tested with coffee and has been accurately adjusted to deliver ground coffee to normal auto drip specifications.

The Grinding Burrs are made of an extremely hard and wear resistant alloy. From time to time, grind adjustments (see following instructions) may be necessary as the burrs wear. If the grind runs coarser than expected after normal adjustment and the grind time has increased, the burrs may have excess wear and should be replaced. New burrs should always be installed as a pair, never one or the other, as they are accurately ground and lapped in pairs. Old burrs cannot be resharpened.

Operation (continued)

Grind Adjustment

Tools required: Phillips screwdriver
Large and small blade screwdrivers
Wrench

1. Remove all beans from hopper and run grinder until all coffee is cleaned out of grinder.
2. Remove Upper Front Plate by removing the (4) screws in the corners, to expose Grinder Cap.
3. Loosen Adjusting Screw Lock Nut by turning counter clockwise.
4. Turn slotted Adjusting Screw clockwise to make grind finer or counterclockwise to make grind coarser. Generally a 1/8 to 1/4 turn will provide the desired adjustment.

NOTE: Use dial on Grinder Cap as reference. Do not turn more than one mark before testing new grind adjustment.

5. After adjustment has been made, tighten Adjusting Screw Lock Nut.
6. To visually inspect grind adjustment, test grind a small portion of coffee and readjust if necessary.

NOTE: Adjusting the grind may alter the portion of coffee dispensed. After grind adjustment, weigh portion and adjust if necessary (See **Portion Adjustment**).

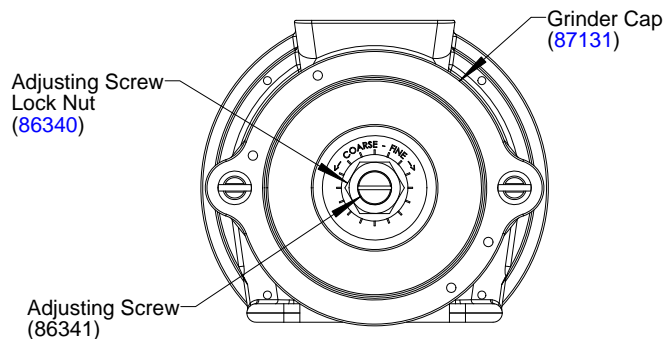

Protection

This grinder is equipped with both a circuit breaker and a shear disc to protect motor and burrs if a foreign object gets into the coffee.

Circuit Breaker

This grinder is equipped with a circuit breaker to protect the motor from overloading. When the circuit breaker trips, the reset button will pop out approximately 1/4" which cuts off the power to the grinder. The reset button is located above the power cord on the back of the grinder. To reset the circuit breaker, push in the button. You will hear a click as it resets. If the grinder does not operate after resetting the circuit breaker, there may be an obstruction in the grinding mechanism that is stalling the motor. In this case, the Grinder Head should be cleaned as described in **Shear Disc Replacement**.

Cleaning & Maintenance

Cleaning Instructions

The outside of the machine can be cleaned with warm soapy water and a damp cloth. Grinding parts should be cleaned with a stiff brush or dry cloth. **DO NOT USE WATER.** See **Shear Disc Replacement** for instructions on assembling and disassembling grinder parts. Before reassembling, wipe motor shaft with dry cloth.

Lubrication

None required.

Shear Disc Replacement

If the motor should run and no coffee is dispensed, the Shear Disc may have sheared. Should this occur, perform the following operations in the sequence given (refer to following drawing).

Tools Required: Phillips Screwdriver
Pliers

▲ WARNING Unplug grinder to prevent electrical shock.

1. Remove the Upper Front Plate of the grinder to provide access to the grinder mechanism.
2. Remove the Grinder Cap by taking out the two Thumb Screws.
3. Pull out the Revolving Burr and Feedworm

Assembly. Clean out the Grinder Head, removing all coffee particles from inside of the Grinder Head and the Grinder Cap so that it can be reset properly.

4. Check that no obstruction has been caught on the surface of the teeth of either burr.
5. Remove the Shear Cap and broken pieces of the Shear Disc. You are now ready to reassemble the grinder mechanism.
6. Slide the Burr and Feedworm Assembly back onto the Motor Shaft making certain that the tongue of the shaft engages the slot in the Shear Drive.
7. Insert a new Shear Disc by aligning the slot in the Shear Drive with the slot in the hub of the Feedworm.
8. Reassemble the Shear Cap and Grinder Cap. Make certain the Grinder Cap is screwed on tight and is sealed properly against the head and not tilted or misaligned. Otherwise a proper grind cannot be obtained.
9. Replace the Upper Front Plate. Your grinder is now ready to grind.
10. Test the grind and adjust as necessary. (See **Grind Adjustment.**)

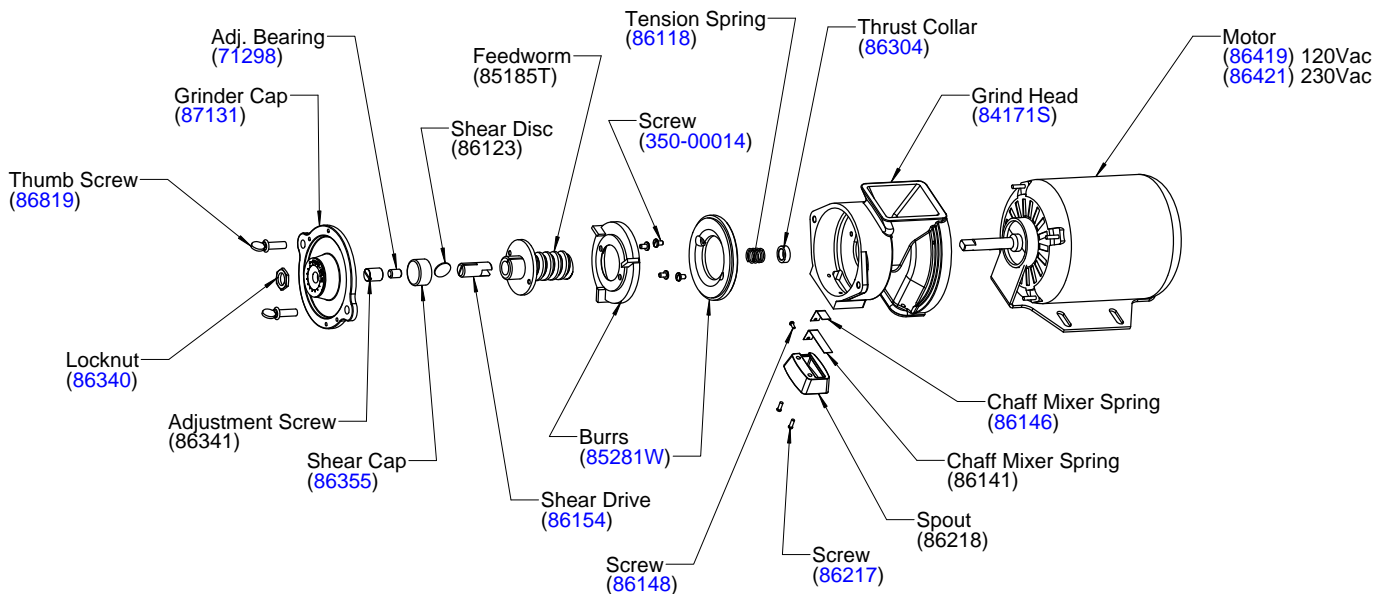

Troubleshooting Guide

Before you call for help, please read the following:

▲ WARNING Unplug power cord from outlet before cleaning or servicing your grinder.

Problem	Possible Cause	Solution
Grinder will not start when START button is pushed	Plug not in outlet properly.	Install plug in outlet.
	No power to outlet.	Check outlet with lamp or radio to verify outlet has power.
	Circuit breaker has tripped.	Reset circuit breaker by pushing in reset button until you hear a click.
Grinder runs or hums but no coffee is dispensed	Shear disc is broken.	Replace shear disc. See Shear Disc Replacement or instructions on inside of upper front plate.
	Obstruction in opening to grinding chamber.	Unplug unit. Empty beans out of hopper and clear obstructions. See Shear Disc Replacement for disassembly and assembly instructions.
Excessive amount of coffee chaff flying about	Defective chaff mixer spring.	If bent, broken, or missing, replace spring. If stuck open with coffee, clean out coffee to free spring.
	Static electricity.	Tighten all nuts, bolts, and screws and verify outlet is grounded.
Quantity of coffee dispensed each throw is not the same	Defective timer.	Check the length of time the grinder runs with watch. If time varies more than plus or minus 1%, replace timer.
Circuit breaker continuously trips	Insufficient current due to use of extension cord.	Plug unit directly into outlet. Do not use extension cord.
	Insufficient current due to overloaded line.	Designate single line for grinder. Do not use multi-outlet box.
	Grind setting needs adjustment.	Adjust grind to coarser setting (see Grind Adjustment).

If you still need help, call Grindmaster-Cecilware Technical Service Department, (502) 425-4776 or (800) 695-4500 (USA & Canada only) (Monday through Friday 8 AM - 6 PM EST). Please have the model and serial number ready so that accurate information can be given.

Prior authorization must be obtained from Grindmaster-Cecilware for all warranty claims.

Grindmaster-Cecilware provides the industry's BEST warranty. Visit our website at GMCW.com for warranty terms and conditions.

Parts Diagram and List

Model 100

Model 100 Exploded View

ITEM #	DESCRIPTION	PART #
1.	STRAIN RELIEF	86071
2.	POWER CORD	86222
3.	UPPER FRONT PLATE	87612
4.	BRACKET, HOPPER	87605
5.	ARM, BASKET LEFT	71013
5.	ARM, BASKET RIGHT	71014
6.	SPRING, BASKET ARM EXT	86508
7.	LOWER FRONT PLATE	86003
8.	SAFETY SHIELD	87604
9.	DEFLECTOR	86220
10.	SPOUT	86218
11.	GRINDER HEAD	84171S
12.	HOPPER GASKET	86228
13.	HOPPER	86192
14.	HOPPER SUPPORT	86008
15.	CAP. GRIND	87131
16.	CHAFF MIXER SPRING	86141
16.	CHAFF MIXER SPRING	86146
17.	MOTOR 120V-UL	86419
18.	TIMER 120V	86456
19.	BASE	86309
20.	ANGLE FASTENER	86862
21.	RUBBER FOOT (1)	86034
22.	CAPACITOR W/BRKT 120V	86144
23.	MOTOR MOUNT W/TMR BRKT	86995
24.	START SWITCH UL-120V	86331
25.	CIRCUIT BREAKER 120V	86618
26.	CASING	87601
27.	FRONT LID	87607
28.	HINGES (2)	86316
29.	BACK LID	86013
30.	WINDOW, SHORT*	89021

* NOT SHOWN

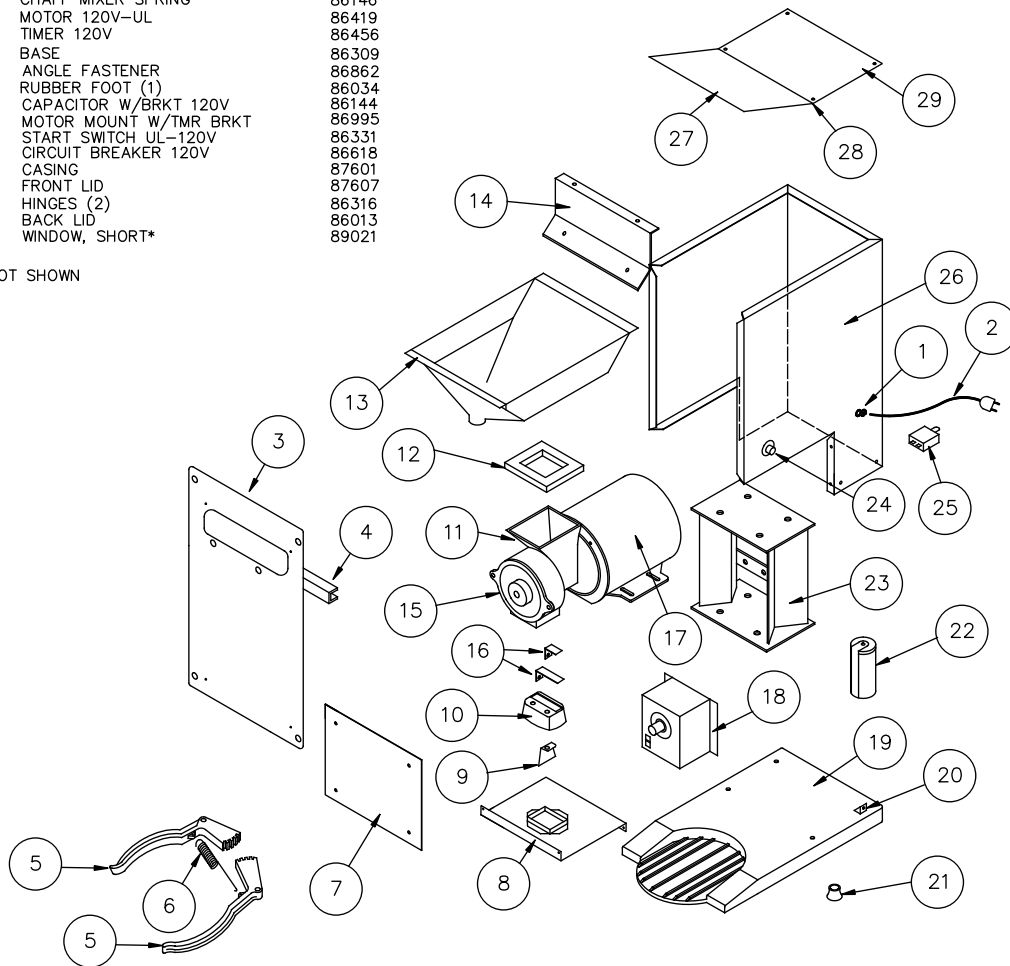

Parts Diagram and List (continued)

Model 190SS

ITEM NO.	DESCRIPTION	190-SS PART NO.	190E-SS PART NO.
1	SCREW, #8x3/8 PH PN HD TYPE	89113	89113
2	HINGE, LID	86785	86785
3	LID, HOPPER 6 LB	83005	83005
4	DECAL, HOPPER WARNING	83024	83024
5	HOPPER 6 LB	83004	83004
6	COVER, 190 TIMER	83233	83233
7	CASING	87600	87600
8	BREAKER, CIRCUIT 10 AMP	86618	-----
	BREAKER, CIRCUIT 5 AMP (230V)	-----	83107
9	RELIEF, STRAIN	86071	86071
10	CORD, POWER	86222	61453
11	TIMER, SOLID STATE 120V	86456	-----
	TIMER, SOLID STATE 230V	-----	86450G
12	BASE, 190	83762	83762
13	MOTOR MOUNT	86995	86995
14	CAPACITOR, W/CAP & BRKT (120V)	86144	-----
	CAPACITOR, W/CAP & BRKT (230V)	-----	86179
15	NUT, TINNERMAN, 1/4-20	86864	86864
16	BOLT, 1/4-20x1 HX HD W/SERF	86872	86872
17	SPRING, CHAFF	86141	86141
	SPRING, CHAFF	86146	86146
18	SPOUT, MACHINED	86218	86218
19	SCR #4-40x1/4" PH PN ZNC	86148	86148
20	DEFLECTOR	86220	86220
21	SCREW, 8-32x3/8 PH FIL HD MS	86217	86217
22	FRONT, LOWER 190	83767	83767
23	PANEL, MIDDLE	87627	87627
24	SWITCH	70445	80079
25	DECAL, 190 FRONT	83020	83020
26	FRONT, 190	87625	87625
27	NUT, 5/16-18 BRASS	86340	86340
28	CAP, GRIND	87131	87131
29	SCREW, GRIND ADJUST	86341	86341
30	COVER, SHEAR	86355	86355
31	BEARING, ADJUST	71298	71298
32	DISC, SHEAR	86123	86123
33	DRIVE, SHEAR	86154	86154
34	FEEDWORM	85185T	85185T
35	BURRS	85281W	85281W
36	SPRING, TENSION	86118	86118
37	COLLAR, THRUST	86304	86304
38	HEAD, GRIND	84171S	84171S
39	MOTOR 1/2 HP 120/60HZ	86419	-----
	MOTOR 1/2HP 230V/50HZ	-----	86421
40	GASKET, HOPPER	86228	86228
41	SOUND DAMPER	86312	86312
42	SCREW, #10 X 1/2	86859	86859
43	T-MAN ANGLE BRACKET	86863	86863
44	SPRING, BASKET ARM	86508	86508
45	NUT, WHIZLOCK 1/4-20	87049	87049
46	SPACER	87026	87026
47	ARM, BASKET LEFT	71014	71014
48	ARM, BASKET RIGHT	71013	71013
49	SPACER	87025	87025
50	SCREW, 5/16X1 HEX SOC SHLDR	87024	87024

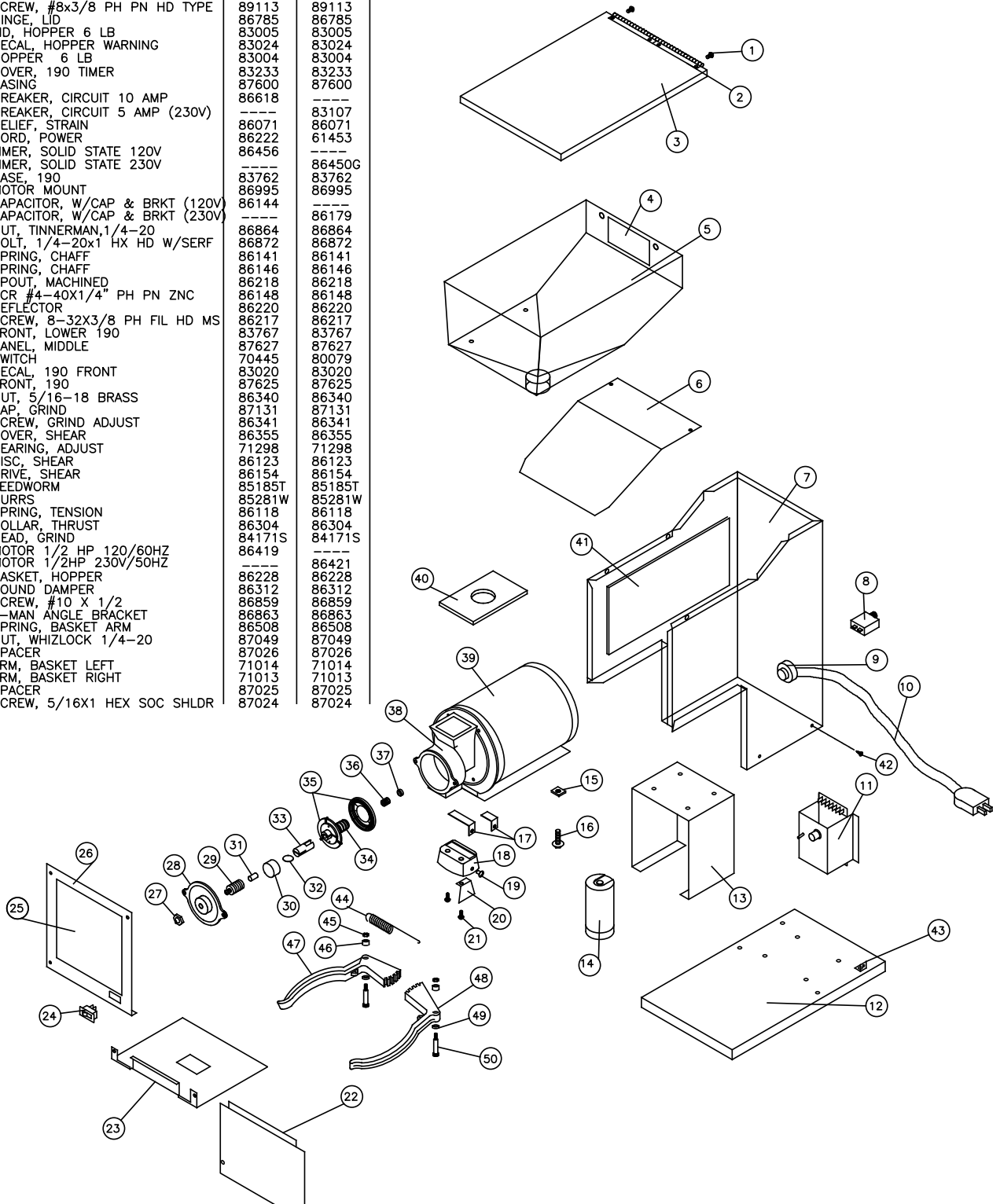

Wiring Diagram

120V, 60Hz Wiring Diagram

(Models 100 & 190-SS for P/N 86456 Timer)

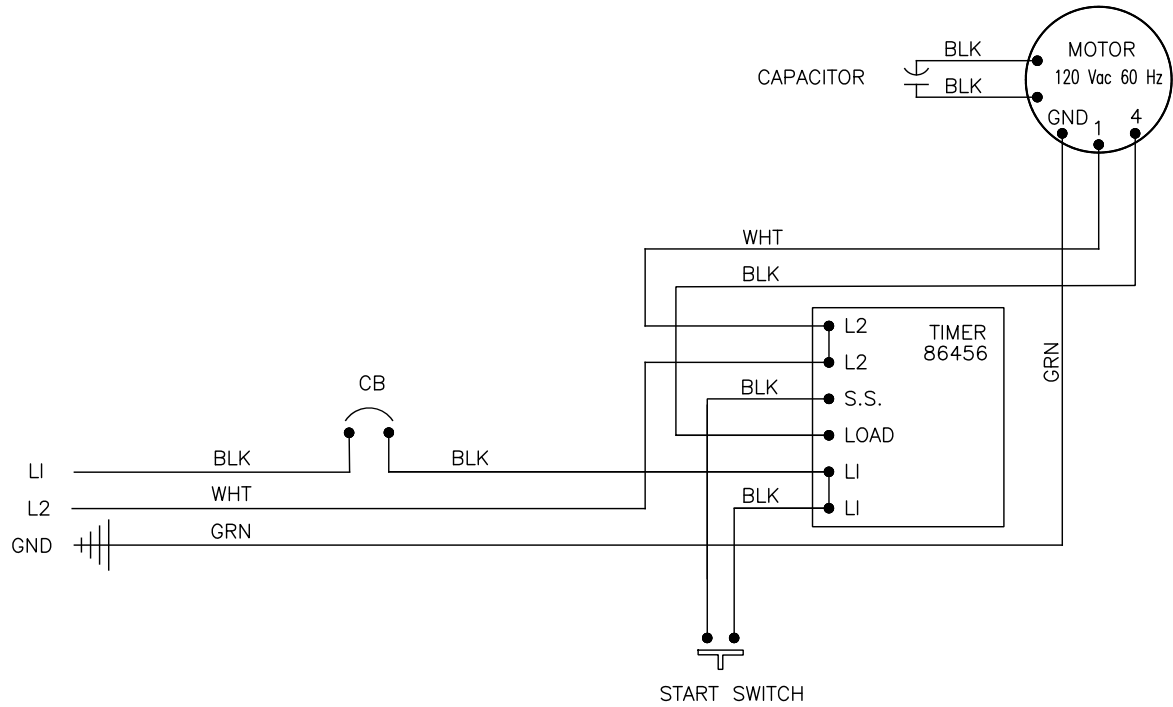

230V, 50Hz Wiring Diagram

(Model 190E-SS for P/N 86450 Timer)

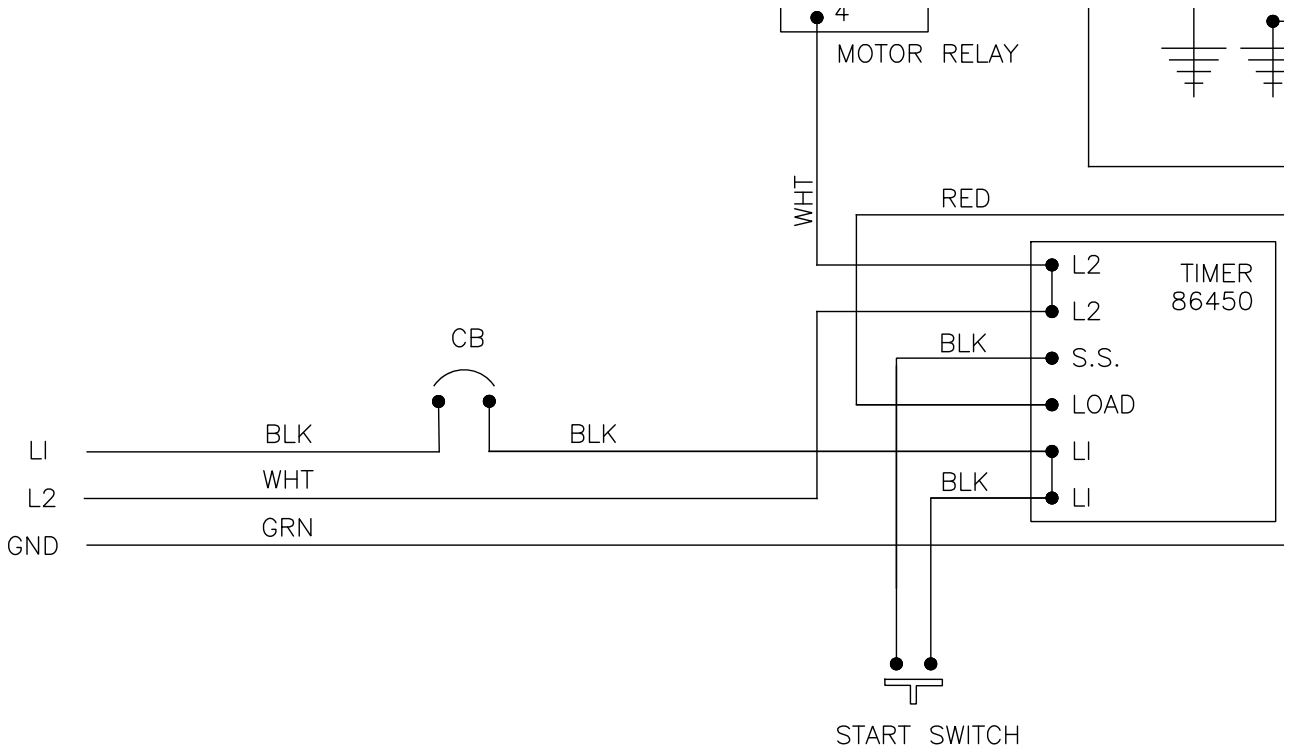

Grindmaster-Cecilware

4003 Collins Lane, Louisville, KY 40245 USA
Phone: 502.425.4776 Toll Free: 800.695.4500
Fax: 502.425.4664
Web: gmcw.com Email: info@gmcw.com

©2015 Grindmaster-Cecilware
Printed in USA



1015 Form # GR-310-09
Part # 390-00050