

American Metal Ware® Hot Water Boiler

Installation, Operation & Service Manual

For

Models 815, 830, 850

Gas

Electric

Steam

TABLE OF CONTENTS

General Description.....	1
Installation.....	1
Thermostat.....	4
Adjustment.....	4
Service Instructions.....	5
Dual Level Control.....	6
Troubleshooting.....	7
Solenoid Valve	
Safety Instructions.....	11
Installation.....	11
Disassembly.....	12
Assembly.....	12
Troubleshooting.....	12
Cleaning.....	12
Testing.....	12
Repair Kits.....	12
Coils.....	12
Parts List.....	13

Special Features

After completing installation and set-up, the equipment owner should keep this manual for future reference.



Grindmaster Corporation™
4003 Collins Lane
Louisville, Kentucky 40245 USA
(502) 425-4776
(800) 695-4500 (USA and Canada only)
(800) 568-5715 (technical service only)
FAX: (502) 425-4664
www.grindmaster.com

Electric Models
815, 830, 850
Equipped with Option 46 Automatic Refill
Option 39 Low Water Cut-Off System

General Description

This unit is a high temperature hot water boiler. It consists of a non-pressure, vented water compartment into which is installed an electric immersion heater thermostatically controlled through a contactor relay, to keep the water always at the desired brewing temperature. Automatic refill maintains water level in water compartment. All control system components are enclosed in a stainless steel housing on the right end of the urn:

A master ON-OFF switch shuts off entire unit, including heater circuit: Separate low water cutoff system protects heater and entire unit from damage.

Installation

1. **IMPORTANT TO ALLOW 6" CLEAR SPACE TO RIGHT ON CONTROL BOX FOR ACCESS.** Urn should be level, both front to back and left to right.
2. **CONNECT WATER LINE.** 3/8" NPT water inlet located at right end. Provide shutoff valve and union in supply line near urn. Cold or hot water may be used, but hot water will give greater gallon per hour capacity. We strongly recommend the use of copper or aluminum tubing to provide flexibility and avoid strain on the unit. 3/8" O.D. Tubing is recommended.
3. **CONNECT URN TO ELECTRIC POWER.** Check to be sure that name plate marking of voltage phase and number of wires matches supply lines. Remove cover on control housing. Terminal block for line connections located in housing on right end. See drawing, as required. It is recommended that a fused disconnect switch be installed near urn. Urn body must be grounded either through metallic conduit or else by means of ground wire. An experienced electrician should be responsible for the installation of the unit, and its associated supply line. **NOTE:** Neutral wire required on all single phase and on 208 volt 3 phase power supplies to operate 120volt AC control circuit. Do not replace cover until completion of installation.
4. **FILL WATER COMPARTMENT.** Turn on water supply and electric service to urn. Turn master switch on. Do NOT turn on thermostat until water shows in gauge glass (approximately 6 minutes). When water shows, remove adhesive **WARNING** label from thermostat knob. Turn thermostat knob maximum clockwise to **BREW** position. Pilot light over knob should light showing heater power on. Water compartment will fill automatically to stop-full level, and should reach operating temperature approximately 45 minutes later. When the pointer on thermometer approaches the "W" in the blue **BREW** zone, unit is ready for operation.
5. **REFILL RATE ADJUSTMENT.** To gain maximum capacity of the boiler, and shorten heat recovery time, adjust the water inlet flow regulator (located inside the control box) according to the chart provided. Turning the threaded adjustment shaft clockwise increases the flow rate, counterclockwise will decrease it.

Installation (cont.)

5) TO CHECK REFILL RATE, allow water to fill to stop/full level automatically; then turn off master switch. Draw off 1 gallon of water from faucet. Turn master switch back on and time how long it takes for the water level to come up to stop/full mark again. Compare time with chart provided and adjust accordingly.

	TIME TO REFILL 1 GALLON	
HEATER SIZE (OR EQUIV. STEAM USE)	COLD WATER* CONNECTION	HOT WATER CONNECTION
5.5KW/208 Volt or 7KW/240 Volt	3min. 30sec.	1min. 25sec.
12KW	1min. 50 sec.	45sec.
15KW	1min. 25sec.	35sec.

*Factory setting

MODEL	GAL DRAIN OFF	HEATER SIZE 5.5 KW 200V/1PH 7 KW 240V/1PH 12 KW 240V/1PH 15 KW	GPH RECOVERY HEATER 13 18 30 38	LBS/HR STEAM CONSUMPTION
815E,S	15		32	18
830E,S	30		44	23
850E,S	50		74	40
			90	50

STANDARD OPERATING STEAM PRESSURE (MODELS WITH SUFFIX "S") IS 10-25 PSIG

MODEL	GAL DRAIN OFF	GAS INPUT BTUH	GPH 50°F INLET	GPH 140°F INLET
815G	15	18000	9	22
830G	30	24000	12	30
850G	50	24000	12	30

NOTE: CONTROL CIRCUIT IS 120 V AC.

GAS INPUT, 3/8" FPT

FLUE ON GAS ONLY

1" MODEL SHOWN: 830 E

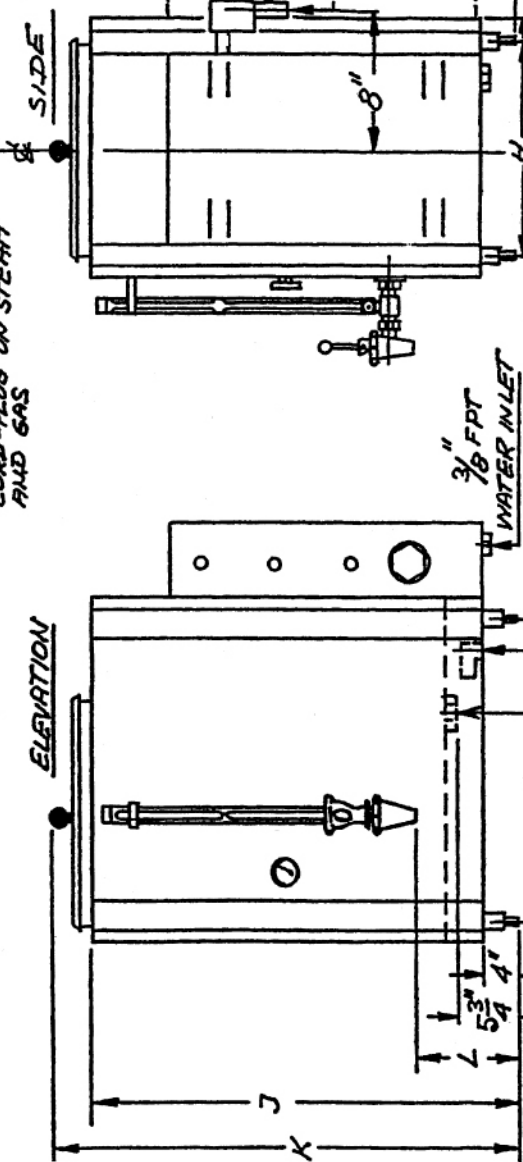
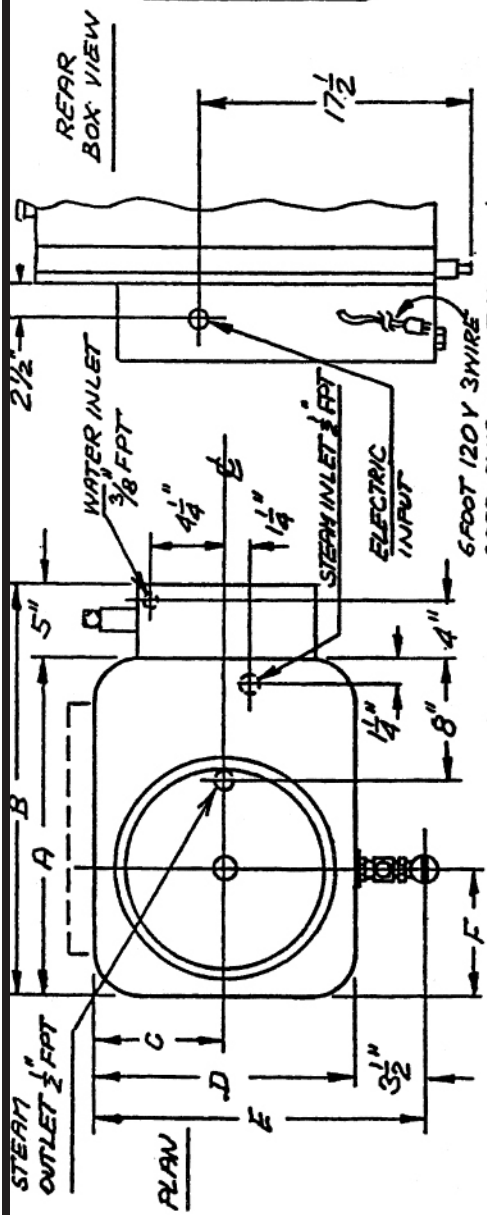

AMERICAN METAL WARE
1835 Raymond Drive, Northbrook, Illinois 60062-6778

SCALE: / MAT'L: /

DRAWN: 2L CHK'D: LRO APP'D: LRO

DATE: 11.28.1983 DATE: 11/28/83

TITLE: ROUGHING-IN SPECIFICATIONS FOR MODEL SERIES 800 WATER BOILERS

DRAWG NO. 090-307

REVISIONS	
NO	DATE / ECN BY
A	11-28-83 WAS DRG. A1179 LRO
B	ECN 853 WJ
C	12-5-89
D	
E	
F	

MODEL	A	B	C	D	E	F	G	H	I	J	K	L
850 G	21	26	8 3/8	16 3/4	20 1/2	8 1/2	18	14	34 1/2	37 1/2	10 1/2	
830 G	21	26	8 3/8	16 3/4	20 1/2	8 1/2	18	14	29 1/2	32 1/2	10 1/2	
815 G	18	23	7 1/2	15	18 1/2	7 3/4	15	12	26 1/2	29 1/2	10 1/2	
850 E,S	21	26	8 3/8	16 3/4	20 1/2	8 1/2	18	14	32	35	8	
830 E,S	21	26	8 3/8	16 3/4	20 1/2	8 1/2	18	14	27	30	8	
815 E,S	18	23	7 1/2	15	18 1/2	7 3/4	15	12	24	27	8	
MODEL	A	B	C	D	E	F	G	H	I	J	K	L

Thermostat

Factory set so that knob on BREW setting holds unit at brewing temperature toward HIGH end of brew zone on thermometer dial. Then, if turned back to HOLD position, thermostat should cycle on and off and hold at LOW 'end of BREW zone on thermometer.

Thermostat Adjustment

1. If water temperature is below HIGH end of BREW zone on thermometer dial with knob on BREW setting, remove knob by pulling straight outward. Using a small screwdriver, insert in hole in center of shaft, turn slotted screw counter-clockwise until red pilot light goes on. Check to see that water in unit holds at HIGH end on BREW zone on thermometer and does not boil.
2. If water boils with thermostat knob set at the BREW position, remove knob by pulling straight outward. Using a small screwdriver, insert into hole in center of shaft, turn slotted screw clockwise until red pilot light goes out. Hold shaft so it does not turn while adjusting screw. Add cold water and check that heat comes back on (Pilot light glows), and that thermostat cycles at temperature at HIGH end of BREW zone on thermometer dial.

If thermostat will not cycle, replace entire control.

Service Instructions

PROBLEM: THERMOSTAT DIAL TURNED TO BREW AND WATER IN COMPARTMENT REMAINS COLD

POSSIBLE CAUSE

1. No power at urn. Check main switch, Check main fuses. (3 on 3 phase power, 2 on single phase power). Check that Pilot Light by On-Off switch is ON.
2. Power at urn, but no power at heater terminals. Check control circuit fuse. Check that pilot light over thermostat dial is lighted with dial set to BREW. Check that water level is at FULL mark on water gauge glass. NOTE: If urn is equipped with Option 39, Low Water Cut-off System, level in gauge glass should be minimum 2 inches showing to have power ON to control circuit. Check low water cut-off and auto refill system and replace if necessary. Check that contactor clicks on and off as thermostat dial is turned from BREW to OFF. Check control transformer if so equipped. Lastly, check for voltage at heater terminals. If OK, check for broken or loose wire on terminal. If necessary, replace heater.

PROBLEM: WATER BOILS CONTINUOUSLY WITH THERMOSTAT DIAL ON POSITION BREW OR HOLD.

POSSIBLE CAUSE

1. Thermostat out of calibration. Set knob on BREW and remove knob by pulling outward. Using small screwdriver in center of shaft, turn slotted screw clockwise until pilot light goes out. Check holding temperature by adding cold water. Red light should come on, and water heat up to HI end of BREW zone on thermometer dial and then shut off. NO BOILING.
2. Thermostat is inoperative. Fluid has leaked out of diastat assembly of thermostat. If impossible to get control to cycle on and off and control temperature, replace entire control. Be sure to drain water in urn below level at which bulb enters urn. Also shut off all power before service is attempted.
3. Relay sticking in closed position. Relay must click on and off. If it sticks, replace.

Dual Level Control Auto Refill And Low Water Cutoff System

I) Dual Level Control: What it does:

- A. AUTO REFILL of the water compartment to keep the tank filled with water. When water is used, the fill valve opens automatically to let in more. The fill valve closes when the water level reaches full.
- B. LOW WATER CUTOFF to prevent burn out of the electric immersion heater when there is not enough water to cover it. When low water occurs, the heat automatically switches off. The heat stays off until more water is added.
- C. A device called a DUAL LEVEL CONTROL keeps the tank filled with water and turns off the heat when water is low by simultaneously monitoring two different water levels.

II) Description and Operation of Dual Level Control System:

A. Components

1. DUAL LEVEL CONTROL - switches power to both the thermostat and water inlet solenoid valve by sensing changes in water level.

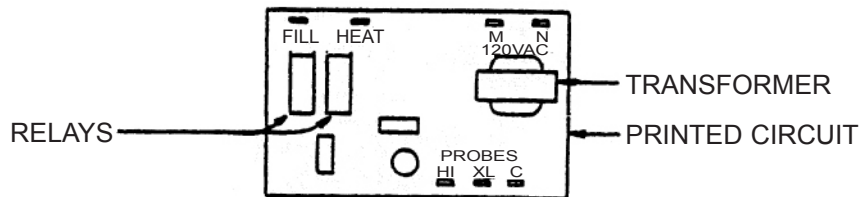

2. ELECTRODE ASSEMBLY - consists of a high (short) and a low (extra long) sensing electrode, or probe, molded in an epoxy body.

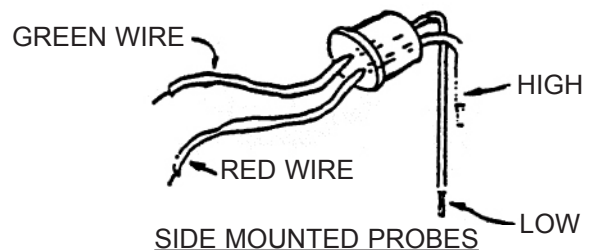
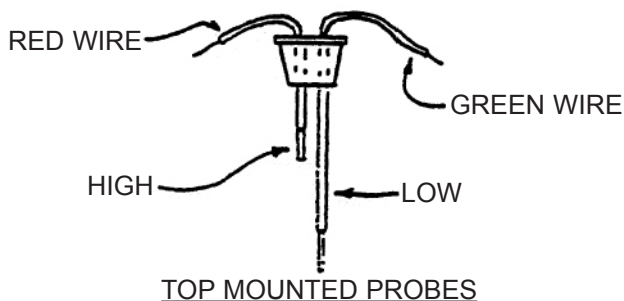

3. METAL ENCLOSURE (TANK BODY) - provides a common (ground) connection for the electrode circuit.

II) Description and Operation of Dual Level Control System (continued)

B. Operation

Water Level

1) Below both electrodes



2) Rises to low electrode above heater coils



3) Rises to high electrode



4) Falls below high electrode only



5) Falls below low electrode
(Same as condition no. 1)

Action

1) Both "HI" and "XL" electrode circuits open. Dual Level Control turns power on to fill valve and keeps power off to thermostat.

Fill Solenoid Valve



Thermostat

2) "XL" electrode circuit closes. Power to thermostat turned on. Power to fill valve remains on.

Fill Solenoid Valve



Thermostat

3) "HI" electrode circuit closes. Dual Level Control turns power off to fill valve and continues power to thermostat.

Fill Solenoid Valve



Thermostat

4) "HI" electrode circuit opens. "XL" circuit stays closed. After a few seconds delay, power to fill valve is turned on.

Fill Solenoid Valve

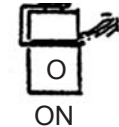

Thermostat

5) "XL" electrode circuit now opens. Power to thermostat is turned off. Power to fill valve remains on.

III) Quick Service Check of Dual Level Control System:

- 1) All wire secure and properly connected.
- 2) Clean the electrodes. Lime (mineral scale) build-up can interfere with the operation of any liquid level control system.
- 3) Check the common (ground) connection. A little looseness or dirt can cause erratic operation.

IV) Trouble Shooting Auto Refill, Low Water Cutoff, and Dual Level Control System

PROBLEM	POSSIBLE CAUSE	SERVICE CHECK	REMEDY
A) Overfilling of water tank when power is off.	1) Fill solenoid valve leaking due to dirt or scale holding valve open, or worn plunger seat.	Visual. Water entering tank continuously, and usually slowly.	Disassemble and clean out. May require new plunger assembly. Caution is advised to avoid damage to valve. See valve instruction sheet.
	2) Fill solenoid valve installed backwards.	Visual.	On valves without integral strainer: Install so that port marked "IN" is connected to outside fresh water supply. On valves with integral strainer: Install so that arrow points in direction of tank, away from fresh water supply.
B) Overfilling of water tank only when power to unit is on.	1) High electrode coated with scale, or faulty.	Jumper from "HI" terminal to metal enclosure stops fill.	Remove electrode assembly. Clean both electrodes. If still no remedy and connections are good, replace assembly.
	2) Missing or faulty common connection for electrode circuit ("C" terminal to metal enclosure).	Jumper "C" terminal (next to XL) to metal enclosure stops fill.	Make good secure connection. May require cleaning or replacement.
	3) Fill valve connected to "HEAT" terminal.	Visual.	Connect "BLACK" wire lead to "FILL" terminal.
	4) Dual Level printed circuit board faulty.	Jumper from "HI" to "C" does not stop fill.	Replace Dual Level Control.
C) Auto refill fails to fill water tank.	1) No power at equipment.	Nothing operates on machine.	Make sure main switch(es), fuse(s), circuit breaker(s) provide power to unit, that machine's circuit breaker is OK and power switch, if provided, is on.
	2) No water at equipment.	"Crack" fitting at water inlet for pressure check.	Make sure all water supply line valves are open.

IV) Trouble Shooting Auto Refill, Low Water Cutoff, and Dual Level Control System (continued)

PROBLEM	POSSIBLE CAUSE	SERVICE CHECK	REMEDY	
C) Auto refill fails to fill water tank (continued).	3) Water strainer clogged.	Water pressure before strainer and not after.	Remove and clean micromesh screen filter located in water strainer.	
	4) No power on Dual Level Control.	Check for 120V AC across "H" and "N" terminals.	If voltage missing or incorrect, check wiring for looseness, breaks, and proper connections.	
	5) Fill solenoid valve clogged with scale or frozen closed.	Disassemble.	Clean out and/or replace plunger assembly or entire valve. May require new coil. Caution is advised to avoid damage to valve. See valve instruction sheet.	
	6) Fill solenoid valve coil inoperative	Jumper from "FILL" terminal to "H" terminal does not start fill.	Replace coil. Also check for frozen plunger. See valve instruction sheet.	
	7) Electrodes shorting to ground.	Tank fills with electrode wire disconnected from "HI" terminal.	Replace electrode assembly. If no remedy, check for improper wiring (cut insulation) or electrode tips touching metal.	
	8) Dual Level Control faulty.	Tank does not fill with electrode wire disconnected from "HI" terminal.	Replace Dual Level Control.	
	D) Auto Refill is erratic.	1) Electrode shorting to ground completely or intermittently.	Tank fills with electrode wire disconnected from "HI" terminal	Replace electrode assembly.
		2) Loose connection.	Visual. Check for "C" and "HI" probe terminals as well as "FILL." Also check neutral (white) wire at valve.	Push wire lead connector securely onto terminal(s). Replace connector if wire is frayed or broken.
3) Dual Level Control faulty.		Tank does not fill with electrode wires disconnected from "XL" and "H" terminals.	Replace Dual Level Control.	

IV) Trouble Shooting Auto Refill, Low Water Cutoff, and Dual Level Control System (continued)

PROBLEM	POSSIBLE CAUSE	SERVICE CHECK	REMEDY
E) Tank fills with water, but heat does not come on.	1) Thermostat off.	Visual.	Make sure knob is turned fully clockwise.
	2) Thermostat inoperative or out of calibration.	Jumper across thermostat terminals causes heat to come on.	Recalibrate thermostat. If no remedy, or thermostat does not cycle, replace.
	3) Power relay or contactor inoperative.	Check for voltage (120V AC) across coil terminals.	If correct voltage, replace coil or entire device. If not correct voltage, check for loose wires, improper wiring or other cause.
	4) Low electrode faulty or covered with lime scale.	Jumper from "XL" terminal to metal enclosure allows unit to heat.	Clean electrodes. Check wiring. If still no remedy, replace electrode assembly.
	5) Dual Level Control faulty.	Jumper from "XL" terminal to "C" does not cause unit to heat.	Replace Dual Level Control.
F) No water in tank, but heat comes on (heater damage likely).	1) Thermostat and fill valve connected to wrong terminals on Dual Level Control.	Visual	Thermostat (brown wire) must be connected to "HEAT" and fill valve (black wire) to "FILL".
	2) Electrode(s) shorting to ground.	Disconnecting wire (white) from "C" probe terminal provides low water heat cutoff and tank fill.	Replace electrode assembly. If no remedy, check for improper wiring (cut insulation for instance), or electrode tips touching metal inside tank.
	3) Dual Level Control faulty.	Heat comes on with no probe wires (HI, XL, C) connected.	Replace Dual Level Control.

NOTE: The level control board works on the principle that water is conductive and with some pure water installations, an increased sensitivity may be required in the level control system. Consult factory if this be the case.

If you still need help, call our service department at (800) 568-5715 Ext. 3 or (505) 425-4776 (Monday through Friday, 8 am - 6 pm EST) or an authorized service center in your area. Please have the model number and serial number ready so that accurate information may be given.

Prior authorization must be obtained from Grindmaster Corporation's Technical Services Department for all warranty claims.



INSTALLATION AND SERVICE INSTRUCTIONS

FOR
202CB and 204CD Series
General Purpose Solenoid Valve

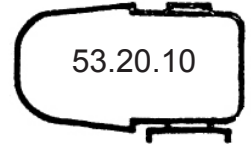

May 1983
Supd's 3-80

Safety Instructions

ATTENTION: Read carefully before attempting to install, operate or service your Alco solenoid valve. Retain for future reference.

1. Read installation instructions- thoroughly. Failure to comply can result in valve failure or system damage or personal injury.
2. Do not use solenoid valves on applications or fluid media not specifically cataloged without prior approval of Alco Engineering Department.
WARNING: DO NOT USE WITH FLAMMABLE OR EXPLOSIVE FLUIDS OR GASES. DO NOT USE IN EXPLOSIVE ATMOSPHERES.
Use on these elements can result in product damage or personal injury.
3. Use of solenoid valves on applications not specifically cataloged can result in valve failure and/or system damage or personal injury. Do not utilize a solenoid valve on any system where the system pressure can exceed the safe working pressure of the valve.
4. CAUTION:
Do not utilize a solenoid valve as a safety shut off.
5. Do not exceed MOPD (Maximum Operating Pressure Differential) or valve may fail to open when energized.
6. CAUTION: Always disconnect power source and depressurize the system before working on solenoid valve or system. If the power disconnect is out-of-sight, lock it in the open position and tag to prevent unexpected applications of power.
7. Direction of flow must correspond to flow Direction Schematics.
8. Before energizing valve, be sure source voltage and frequency matches that on coil. Do not energize coil unless coil is securely attached to valve. See Coil Installation Instructions.
9. Prolonged use in excessive ambient temperature or humidity may damage coils.
10. Do not dent or bend or use enclosing tube as lever. A damaged enclosing tube may result in coil burnout or inoperative valve.
11. Foreign matter in the valve may result in seat leakage, sticking open or closed, or coil burnout. To prolong valve life and ensure system cleanliness use a strainer.

Installation

Valve and Solenoid Position

1. For ease of installation, an Alco solenoid valve can be installed in any position...gravity does not affect its operation.

NOTE: Although all valves can be operated in any position, by mounting the valve upright there is less chance of malfunction caused by the collection of foreign material.

2. The solenoid coil can be rotated 360° for ease of wiring. If possible do not reduce the length of the solenoid coil wire leads, so that if it becomes necessary to remove coil at a later date (for valve cleanout, etc), wire leads will not have to be disconnected.
3. To allow for removal of the solenoid coil without removing the valve from its piping, allow at least 2 inches of clearance above the solenoid.
4. Be sure valve is installed so that its flow arrow on valve body corresponds to direction of flow through piping.

FLUID TEMPERATURE RATING F°

Elastomer Code	Coil Code	
	AMG, AMC	AHG, AHC
B	180	
P	250	
N	180	
F	180	
T		385
V	250	

Identify valve elastomer code and coil code from valve model number and reference rating from table.

Valves are rated for use on air or other non-hazardous, non-toxic fluids, water and other aqueous, non-hazardous fluids, and steam.

Coil Installation Instructions

1. Before removing coil from valve, disconnect electrical power source. Failure to do so will cause coil to burn out.
2. Verify coil type, voltage and frequency. This information appears on the coil nameplate.
3. Place coil over the enclosing tube. Coil may be rotated 360° for easy wiring. It is recommended that coil lead connections be soldered on D.C. and 24V - 50/60 Hz. applications.
4. Install valve nameplate. Pull tab on valve nameplate and peel off paper backing to expose adhesive. Stick nameplate on top of coil housing and press nameplate down firmly. If installing replacement coil, use valve nameplate supplied with valve. Press nameplate down firmly.
5. Install voltage nameplate and coil retainer. Press coil retainer down firmly to secure coil.

Wiring

1. Be sure your wiring conforms to all local and national electric codes.
2. For dual voltage coils, refer to the wiring schematic label on side of coil.
3. The coil circuit of each solenoid valve should be protected by adequate fuses.

WARNING

If not properly grounded, a hazard of electrical shock may exist. Install and ground unit in compliance with National, state, and local electrical codes.

Disassembly

Disassemble in the same general order as indicated in exploded-view illustrations except as noted in the following steps:

1. De-pressurize valve and disconnect electrical power source.
2. To remove solenoid coil:
Insert small screwdriver into gap in voltage nameplate. Slide screwdriver tip under coil retainer and snap off. If replacing coil, use knife to separate adhesive-backed valve nameplate from coil. Keep valve nameplate.
3. To remove collar, use service tool X11981-1 shown in Figure 1.

Notes: Do NOT Lose Nameplate, as it is extremely important if it becomes necessary to order a parts kit, coil or duplicate valve .

Assembly

1. Assemble in the reverse general order of disassembly.
2. Lubricate gasket and "O" ring sparingly with a compatible lubricant such as a Silicon base lubricant.
3. All moving parts, must move freely over the full length of its intended travel.

Troubleshooting

1. Check system fuses, electrical wiring and system source voltage as specified.
2. Is flow direction arrow on valve the same as system flow direction?

Cleaning

As with all valves, it may become necessary to clean them periodically to keep them in peak operating condition. Any cleaning methods or fluids used should be compatible with valve materials.

Inspection

1. All moving parts and elastomers should be clean in appearance without permanent set springs should be free of corrosion. If any appear damaged, replace them with a parts kit which contains all moving parts necessary to rebuild valve to an "as new" condition.
2. Inspect enclosing tube assembly for wear, exterior dents or other conditions which would impair free movement of the poppet and/or plunger assembly. Its interior should be clean and free from any obstructions. Be especially critical of its valve seat.

Testing

1. Apply correct voltage to valve solenoid and cycle solenoid several times. A distinct click should be heard each time the solenoid is energized.
2. Pressurize valve and check for leaks.

Note: Alco solenoid valves are equipped with a continuous-duty solenoid coil, which when energized for an extended period of time becomes hot to the touch...this is a safe operating temperature. Any excessive heating will be indicated by smoke and odor of burning coil insulation.

3. Are all system relays operating?
4. Is system source pressure as specified?
5. Are all system components free from obstructions?

Repair kits

The following Repair Kits are available:

VALVE SERIES	KIT PART NO.	VALVE SERIES	KIT PART NO.
202CB -B	K-1063	204CD -B	K-1072
202CB -F	K-1066	204CD -F	K-1075
202CB -N	K-1067	204CD -N	K-1073
202CB -P	K-1064	204CD -P	K-1076
202CB -T	K-1068	204CD -T	K-1077
202CB -V	K-1065	204CD -V	K-1074

VALVE SERIES	KIT PART NO.
For 1/4" Orifice Only	
204CD -B	K-1162
204CD -V	K-1164
204CD -T	K-1167
204CD -P	K-1166

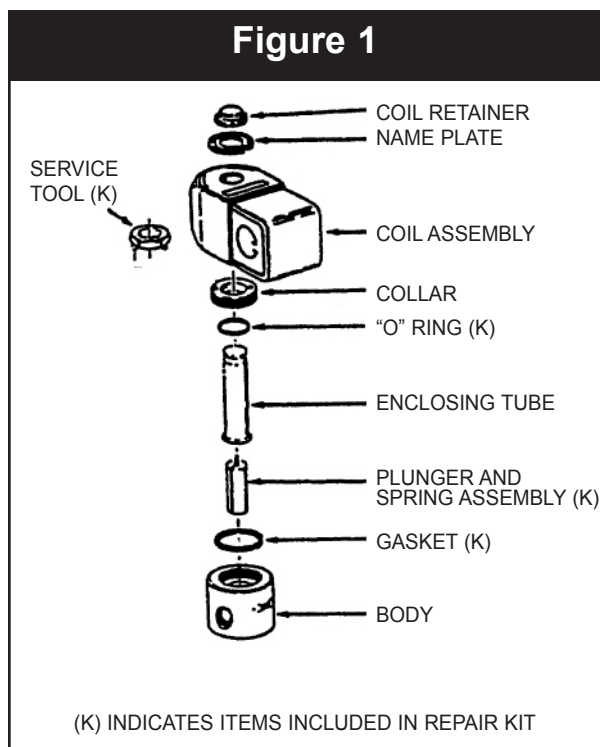

Coils

1. Junction box (AMG) is supplied as standard on all valves.
2. The following coil housings are available:
 - a. Conduit Connection (AMC)
 - b. GROMMET 113" Leads (AML)
 - c. Open Frame (AMF)
 - d. Spade Connection (AMS)
3. Use only Alco coils on Alco valves.



ALCO CONTROLS DIVISION • EMERSON ELECTRIC CO.
P.O. BOX 12700 • ST. LOUIS, MISSOURI 63141 • 314-569-4500
CUSTOMER SERVICE • 314 569 4666



Parts List

815, 830, 850 - Electric, Gas or Steam Heat

<u>AMW Part #</u>	<u>Description</u>
522004	Aluminum Gauge Shield Only for 815 - 5/8" x 13"
522006	Aluminum Gauge Shield Only for 830 - 5/8" x 16"
522010	Aluminum Gauge Shield Only for 850 - 5/8" x 20"
522034	Gauge Glass Only for 815 - 5/8" x 13"
522036	Gauge Glass Only for 830 - 5/8" x 16"
522129	Gauge Glass Only for 850 - 5/8" x 20"
522030	Aluminum Bracket for Gauge Shield
522026	Upper Gauge Glass Washer
522027	Lower Gauge Glass Washer
A-682	Gauge Shield Cap for Plug-in Cleanout Cap
A-1132	Plug-in Cleanout Cap w/Vent Hole
522094	Water Faucet
522102	Silicone Seat Cup for Faucet
532064	Water Line Strainer
506001	Thermometer
549-000	Dual Liquid Level Control
712-017	Electrode Assembly for 815, 830
712-007	Electrode Assembly for 850
505021	Adjustable Water Flow Regulator (1/4- NPT)
504001	Thermostat
515017	Red Pilot Light
537-060	Solenoid Valve, Water Inlet
537-061	Repair Kit for Solenoid
515012	On-Off Master Switch
<u>Electric Heat Only</u>	
514009	Heater Contactor - 3 Pole
514005	Heater Contactor - 4 Pole Control
515043	Control Circuit Transformer
515072	Circuit Breaker
535-_____	Heater -- specify model and serial number, voltage, watts and phase
<u>Steam Heat Only</u>	
506009	Steam Solenoid Valve - 10-40 PSI
506014	Repair Kit for Steam Solenoid
506016	Replacement Coil Only for Steam Solenoid
532027A	Steam Strainer
<u>Gas Heat Only</u>	
504002	Gas Solenoid Valve
504024	Thermocouple
504038	TS11K Gas Safety Valve
504026	Coil for Gas Solenoid
504023	Pilot Burner with Orifice - Natural Gas
504025	Pilot Burner with Orifice - L.P. Gas
505007	Gas Pressure Regulator - Natural Gas
505039	Gas Pressure Regulator - L.P. Gas

IMPORTANT: Give Model Number and Serial Number when ordering

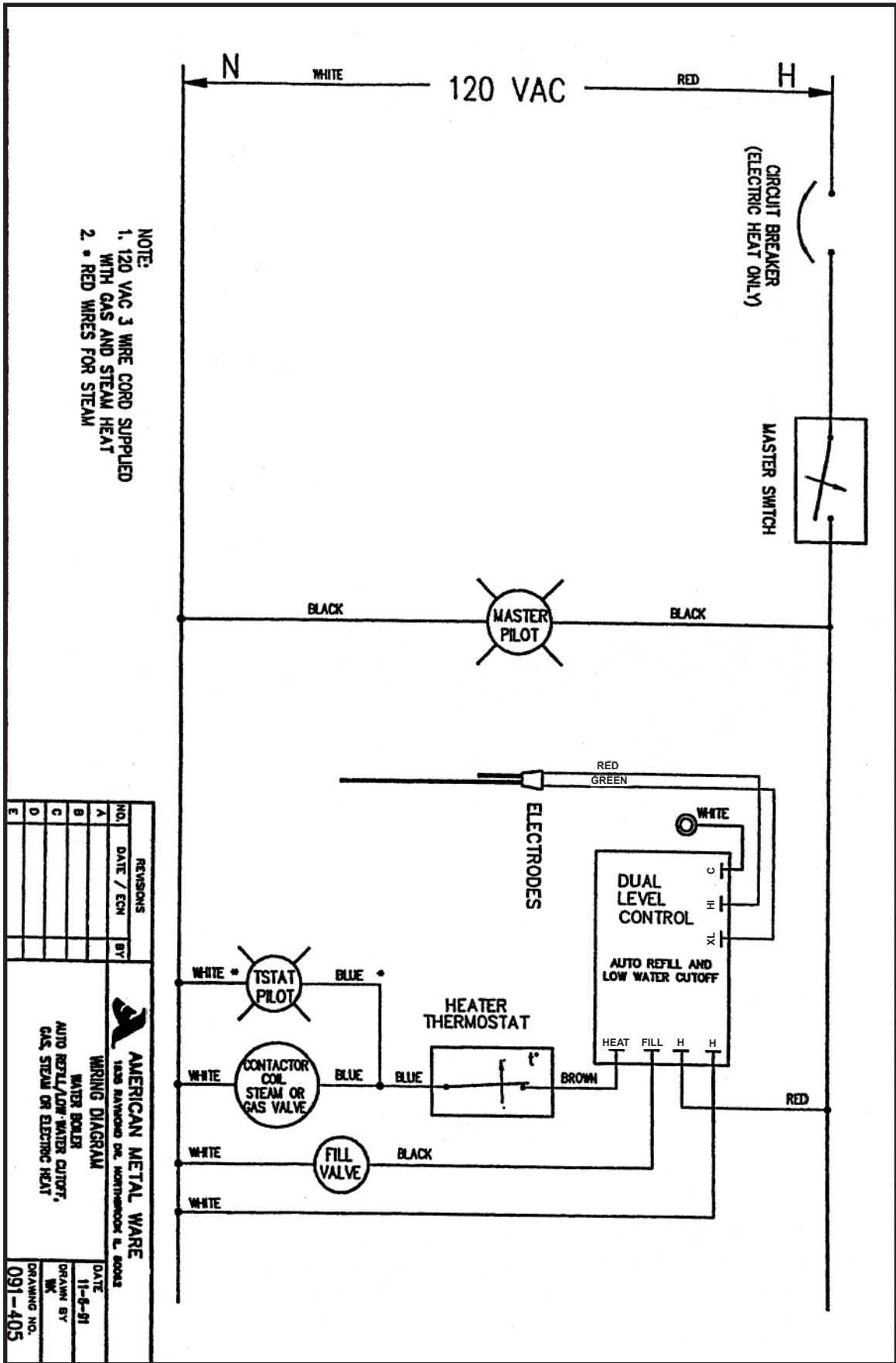

REVISIONS	
NO.	DATE / ECH BY
A	
B	
C	
D	
E	

AMERICAN METAL WARE
 1525 HANCOCK DR. NORTHMOOR, L. 80008

WIRING DIAGRAM
 WATER BOILER
 AUTO REFILL/LOW WATER CUTOFF,
 GAS, STEAM OR ELECTRIC HEAT

DATE: 11-6-91
 DRAWN BY: MK
 DRAWING NO. 091-405



GRINDMASTER™

C O R P O R A T I O N

Grindmaster® Coffee Grinders and Brewers • Espresso® Espresso Machines • Crathco® Hot Beverage Dispensers
Crathco® Cold and Frozen Beverage Dispensers • American Metal Ware® Coffee and Tea Systems
Tel (502) 425-4776 • Fax (502) 425-4664 • 1-800-695-4500
P.O. Box 35020 • Louisville, KY 40232 • USA
www.grindmaster.com • email: info@grindmaster.com