



GRINDMASTER™

CORPORATION

AUTO-SERIES BREWERS

Installation, Operation, and Service Manual

TABLE OF CONTENTS

Warning Labels	3
Water Connection	4
Installation Instructions	4
Coffee Preparation Procedures	5
Brew Volume Adjustment	5
Brew Basket Rail Adjustment	5
Spare Parts List	6
Water Tank Assembly Drawing	7
AT-2W/AT-2WE Drawing	8
AT-AP/AT-APE Drawing.....	9
AT-3WR/AT-3WRE Drawing	10
AT-TC/AT-TCE Drawing	11
AT-3W/AT-3WE Drawing	12
Troubleshooting Guide	13
Component Replacement Instructions	14

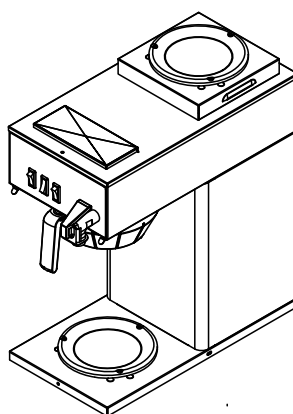

Model AT-2W/AT-2WE

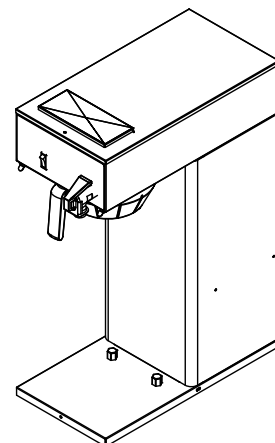

Model AT-AP/AT-APE

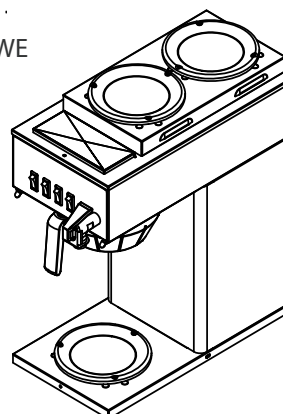

Model AT-3W/AT-3WE

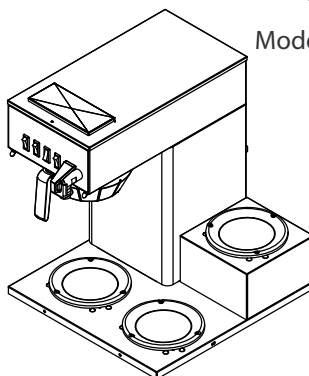

Model AT-3WR/AT-3WRE

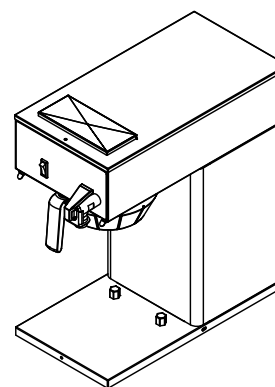

Model AT-TC/AT-TCE

Prior authorization must be obtained from Grindmaster Corporation™ for all warranty claims.



GRINDMASTER™
CORPORATION

Grindmaster Corporation™
4003 Collins Lane
Louisville, Kentucky 40245 USA
(502) 425-4776
(800) 695-4500 (USA and Canada only)
(800) 568-5715 (Technical Service only)
FAX: (502) 425-4664
www.grindmaster.com

WARNING LABELS

The following warning labels were on your dispenser when it was shipped from the factory. They should remain on your dispenser in good, readable condition at all times. If one of your labels is missing or damaged, order a replacement label immediately.

Part # 71509 (for warmer models only)
 Located near warmer plates



Part # 71582
 Located on rear and top access panels



Part # 70248
 Located on front, behind server



Part # 71949 or 71149
 Located on brew basket

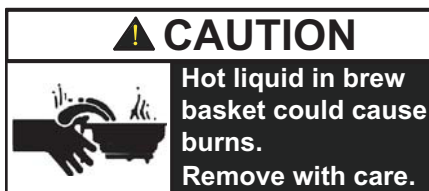

Part #71949



Part #71149

 **WARNING** - Read and follow installation instructions before plugging or wiring in machine to electrical circuit. Warranty will be void if unit is connected to any voltage other than that listed on the name plate.

FILL BREWER TANK WITH WATER BEFORE CONNECTION TO POWER SUPPLY

WATER CONNECTION

The following is required for water hook-up:

- 1) A quick disconnect water connection or enough coiled tubing so the machine can be moved for cleaning underneath. (required for NSF approved water hook-up)
- 2) A 1/4" male flare adapter is provided to be attached by the installer to the back of the machine for hook-up to water supply.
- 3) Installation to a water filter system is required to prevent lime and scale build up in the machine.
- 4) Water pipe connections and fixtures directly connected to potable water supply shall be sized, installed, and maintained in accordance with Federal, State, and Local codes. (required for NSF approved water hook-up)
- 5) Equipment is to be installed with adequate backflow protection to comply with applicable Federal, State, and local codes. (required for NSF approved water hook-up)

Minimum water pressure to the machine: 30 psi (2.0 bar)

Maximum water pressure to the machine: 80 psi (5.6 bar)

INSTALLATION INSTRUCTIONS

- 1) Place the decanter under brew basket, raise top evaporation cover and pour three decanters of water through the top pour-in opening. Water should come through the brew basket as the third decanter of water drains out of the pour-in basin.
- 2) Brewer is shipped with thermostat turned on, (full clockwise position). Plug brewer into a dedicated, grounded 120V/15A circuit (230V/15A circuit for E models).
- 3) Allow 10-15 minutes for water in tank to heat to brewing temperature. (Hot water may drip from brew basket on initial thermal expansion of water in the tank). This will not occur thereafter.
- 4) After water has reached brewing temperature (thermostat will click off, heating noise will stop and green ready light will be on) pour 1 decanter (60 oz./1.8L) of water through pour-in opening. Machine is now ready to use.
- 5) Pour 1 decanter of water through pour-in opening to check for proper temperature setting with an accurate thermometer. Take the temperature of this water at a point below the brew basket opening at the start of the brew cycle and when the decanter is half full. Recommended temperature of the water is approximately 195°F (91°C) .
- 6) In higher altitude locations (5,000 feet/1,500m above sea level) the thermostat may have to be adjusted lower to prevent boiling.

COFFEE PREPARATION PROCEDURES (Pour-Over Mode)

- 1) Place filter into brew basket.
- 2) Put the proper amount of coffee into the filter.
- 3) Slide the brew basket into holder.
- 4) Place empty decanter on warmer located directly under the brew basket and turn corresponding warmer switch ON.
NOTE: For airpots, open airpot lid, remove pump stem from airpot and place airpot opening directly under center hole in brew basket.
- 5) Pour decanter of fresh water through pour-in opening at top of brewer.
- 6) Hot water will be delivered through the sprayhead. This distributes the hot water evenly over the coffee bed within the brew basket. The coffee will drain from brew basket into the container below.
- 7) TURN OFF WARMER WHEN NOT IN USE. (Red light indicates warmer is ON.) Not for airpot brewers.
- 8) Before brewing next pot, remove brew basket from brew rails and dump filter into waste basket.

COFFEE PREPARATION PROCEDURES (Auto Mode)

- 1) Place filter into brew basket.
- 2) Put the proper amount of coffee into the filter.
- 3) Slide the brew basket into holder.
- 4) Place empty decanter on warmer located directly under the brew basket and turn corresponding warmer switch ON.
NOTE: For airpots, open airpot lid, remove pump stem from airpot and place airpot opening directly under center hole in brew basket.
- 5) Press Brew switch once then release.
- 6) Valve will turn on approximately 1 minute and fill pour-in basin.
- 7) Hot water will be delivered through the sprayhead. This distributes the hot water evenly over the coffee bed within the brew basket. The coffee will drain from brew basket into the container below.
- 8) TURN OFF WARMER WHEN NOT IN USE. (Red light indicates warmer is ON.) Not for airpot brewers.
- 9) Before brewing next pot, remove brew basket from brew rails and dump filter into waste basket.
- 10) Do not press Brew switch more than once during brew cycle.

BREW VOLUME ADJUSTMENT

- 1) Disconnect power to brewer.
- 2) Remove plug on upper left side of chassis.
- 3) With a flat head screwdriver, turn dial clockwise slightly to increase volume and counter-clockwise to decrease volume.

Reference timer setting:

Water Pressure (psi)	Timer setting (sec)	Volume (oz)
35	64	64
40	63	64
50	62	64

- 4) Reconnect power and run a brew cycle to check volume.
- 5) Repeat steps 1-3 if necessary.

BREW BASKET RAIL ADJUSTMENT

- 1) Disconnect power to brewer.
- 2) Remove lid and pour-in basin.
- 3) Loosen nuts for brew rails.
- 4) Fit basket in place.
- 5) Tighten nuts and check basket fit.

SPARE PARTS LIST

Item No.	Part No.	Description	Item No.	Part No.	Description
1	73035	Water Tank	38	73242	Hole Plug
2A	73252	Clamp Hose, Nylon .468" ID	39	71093	Pipe Adapter
2B	73283	Clamp Hose, Nylon .531" ID	40	73179	Timer Relay, 120V
3	71155	Tubing, 5/16"ID x 1/2"OD Silicone		73251	Timer Relay, 230V
4	73318	Heat Exchanger Inside Tank 3/8" ID	41	73114	Bracket, Panel Spray HD
5	70818	Element, Heating 1400W 120V	42	73003	Top Cover SS, AT-AP, AT-3WR
	70820	Element, Heating 2500W 240V	43	71607	Panel, Pour-Over Lid
	73222	Element, Heating 1780W 120V	44	71529	Wire Hinge, Pour-Over Lid
6	73037-1	Inlet Tube Assembly	45	73008	Nut Slotted Hex SS (size M20x1.5)
7	73186A	Cover, Tank W/Bracket, Thermostat	46	73010	Pan, Receiving
8	61143	Nut, Pipe Jam 1/8" NPT	47	73175	Assy, Water Line to Faucet
9A	73317	Fitting Brass 1/4"MFL x 3/8"NPT	48	73188A	Top Body Assembly AT-AP, AT-TC
9B	73177	Fitting Brass 1/4"MFL x 1/4"NPT	49	73191	Panel, Back AT-AP, AT-APE
10	73033	Elbow Brass, 1/8" NPT 3/8" Barb	50	73291	Valve Inlet 120V, 50/60Hz
11	61243	Grommet, Dump Valve		73298	Valve Inlet 230V, 50/60Hz
12	73178	Fitting, 1/4"MFL x 3/8" Barb	51	73021	Bracket, Tank Base AT-AP, AT-APE
13	73234	Tube, Inner Braided Silicone	52	73192	Panel Center SS. AT-AP, AT-APE
14	60550	Clamp Hose, Stainless	53	73190	Panel, Back AT-TC, AT-2W, AT-3WR
15	73036	Thermostat Regulating	54	73213	Base Tank
16	61150	Valve, Ambient Flow Control Assy	55	73185	Panel Center SS. AT-TC, AT-2W, AT-3WR
17	62237	T-Stat, Hi-Limit, 120V Models	56	73029	Base Cover Panel, AT-2W, AT-3W
	100523	T-Stat, 1/2" Manual Reset 230V Models	57A	73321-1	Decal, Main Front AT-2W
18	62238	Bracket, Hi-Limit 120V Models	57B	73321	Decal, Main Front W/Switch Power AT-2W
	100524	Bracket, Hi-Limit Manual Reset 230V Models	58	73031	Panel, Warmer Top AT-2W
19	73095	Bracket, Water Tank	59	73001	Bracket, Warmer
20	73057	Gasket, Tank O-Ring	60	73002	Plate, Warmer
21	73096	Thermostat Clip Lock	61	13029	Heater, Warmer 120V, 100W
22	61232	Plug 3/8" Barbed		A535-028	Heater, Warmer 220V, 100W
23	73028	Leg, Support	62	73004	Top Cover SS, AT-2W
24	73026	Base Welded	63	73218A	Top Body Assembly AT-2W
25	73024	Base Cover Panel, AT-AP, AT-AC	64	73079	Base Welded AT-3WR
26	73027	Airpot Stopper	65	73080	Base Cover Panel, AT-3WR
27A	73183	Rail Brew, RH. Assembly	66	73078	Panel, Warmer 3RD, AT-3WR
27B	73182	Rail Brew, LH. Assembly	67A	73319-1	Decal, Main Front AT-3WR
28	71952	Brew Basket	67B	73319	Decal, Main Front W/Switch Power AT-3WR
29	73249	Pressure Faucet	68	73184A	Top Body Assembly AT-3WR
30	63495	Ready Light, Green 120V	69	61237	Fitting Assembly 1/4MFL x 3/4Hs Brass
	61125	Ready Light, Green 240V	70	73292	Elbow, Barbed 3/8" Hose ID x 3/8" NPT
31	70445	Brew Switch	71	73294	Orifice, Flow Control, 0.5 GPM
32A	73058	Switch Warmer Lighted 230V	72	73293	Barb, 3/8" Hose ID x 3/8" NPT
	73059	Switch Warmer Lighted 120V	73	73312	Grommet Pipe Connect Silicone
32B	73194	Switch Power - Optional	74	73315	Bracket, Pipe Connect
33A	73320-1	Decal, Main Front AT-AP, AT-TC	75	73313	Pipe connect 1/4" OD
33B	73320	Decal, Main Front W/Switch Power AT-AP, AT-TC	76	73314	Tubing Silicone 0.2" ID x 0.5" OD
34	06491	Deflector, Spray HD	77A	73297-1	Decal, Main Front AT-3W
35	06490	Nozzle, Spray HD	77B	73297	Decal, Main Front AT-3W, W/Switch Power
36	07220	Nut, Lock Palnut Spray HD	78	73287	Top Cover SS, AT-3W
37	70341	Elbow, Silicone 90 deg	79	73288	Panel, 2 Warmers

Not shown:

61530

Power Cord, 120V

61453

Power Cord, 230V

WATER TANK ASSEMBLY

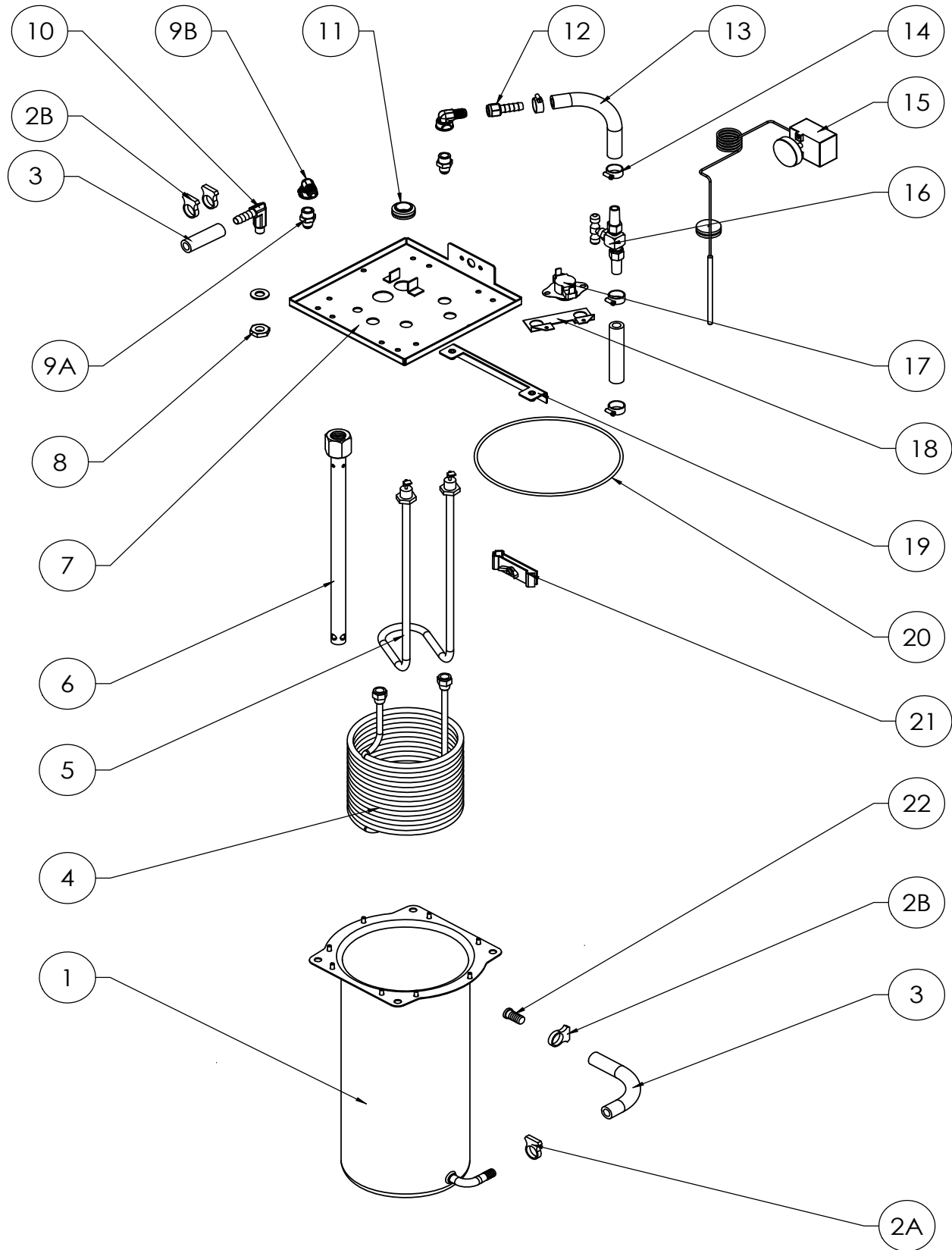

AT-2W/AT-2WE PART LIST

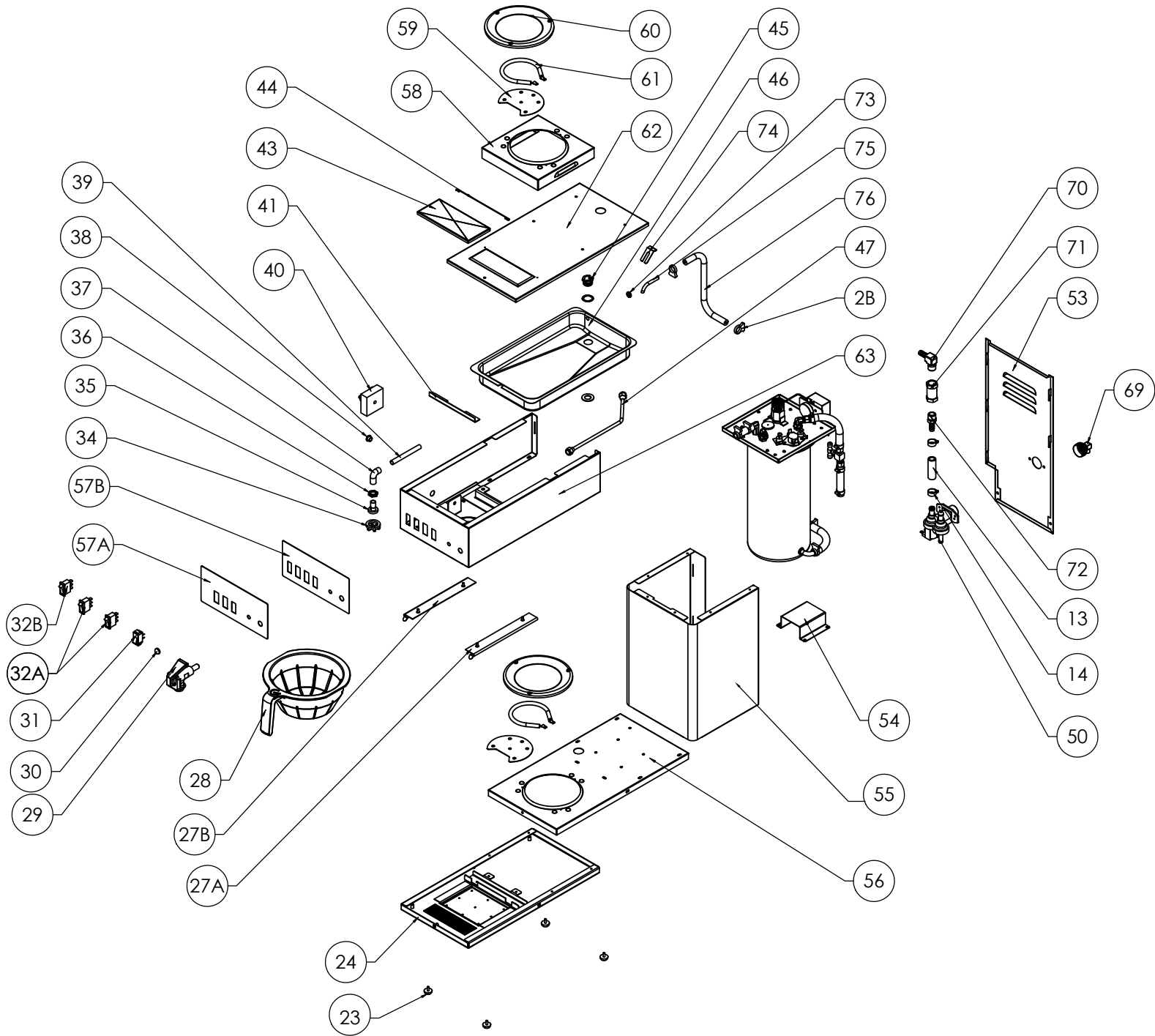

AT-AP/AT-APE PART LIST

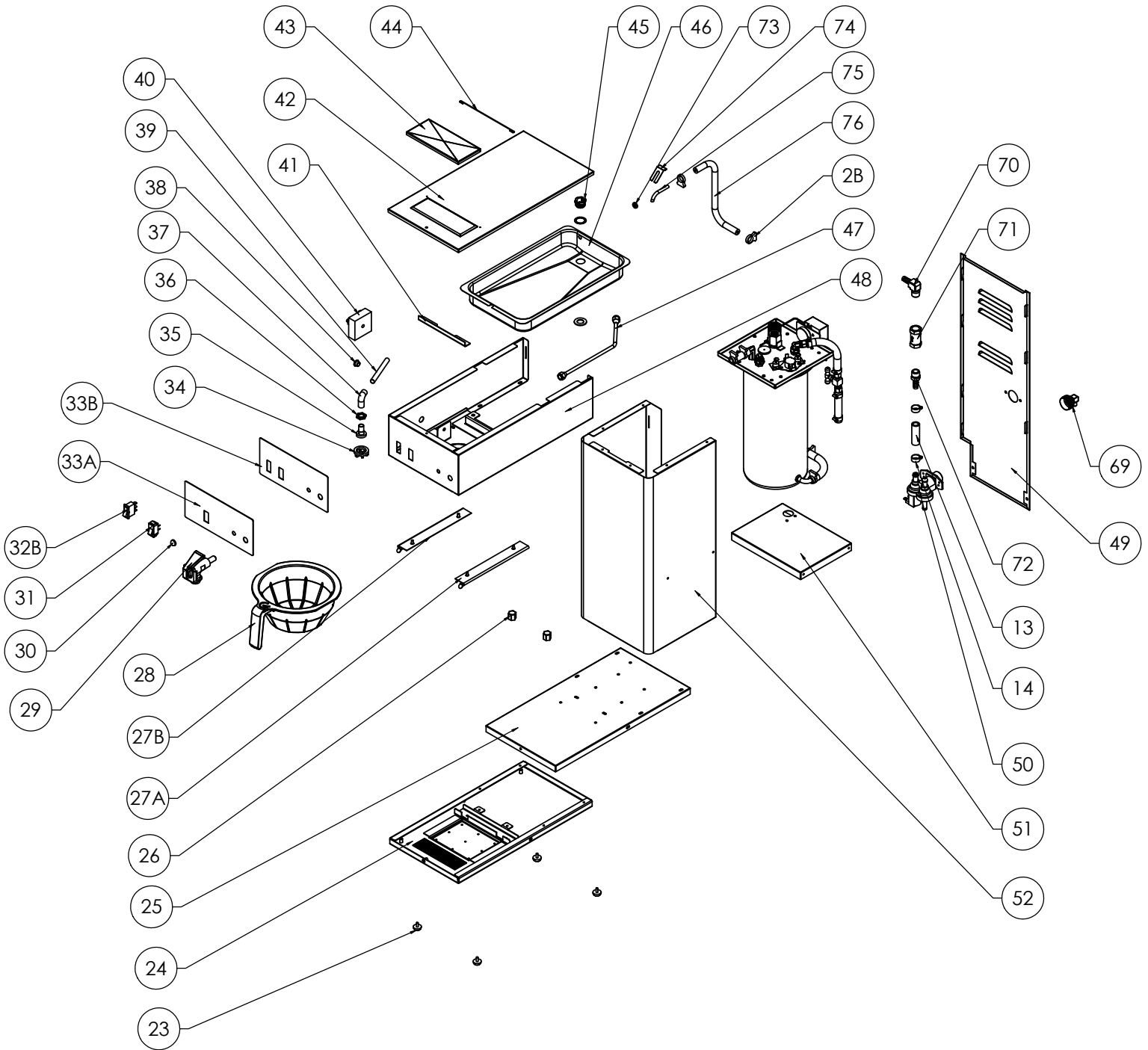

AT-3WR/AT-3WRE PART LIST

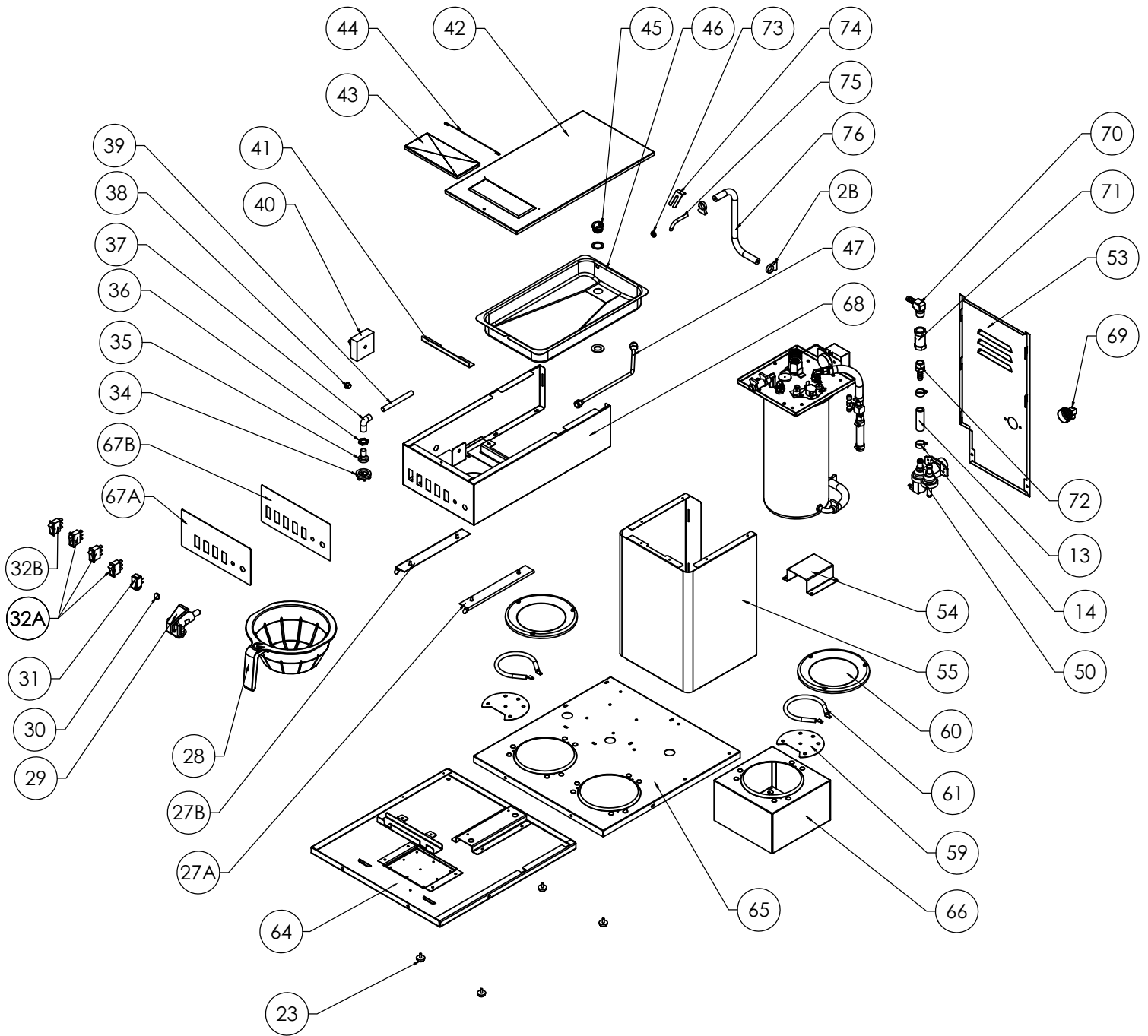

AT-TC/AT-TCE PART LIST

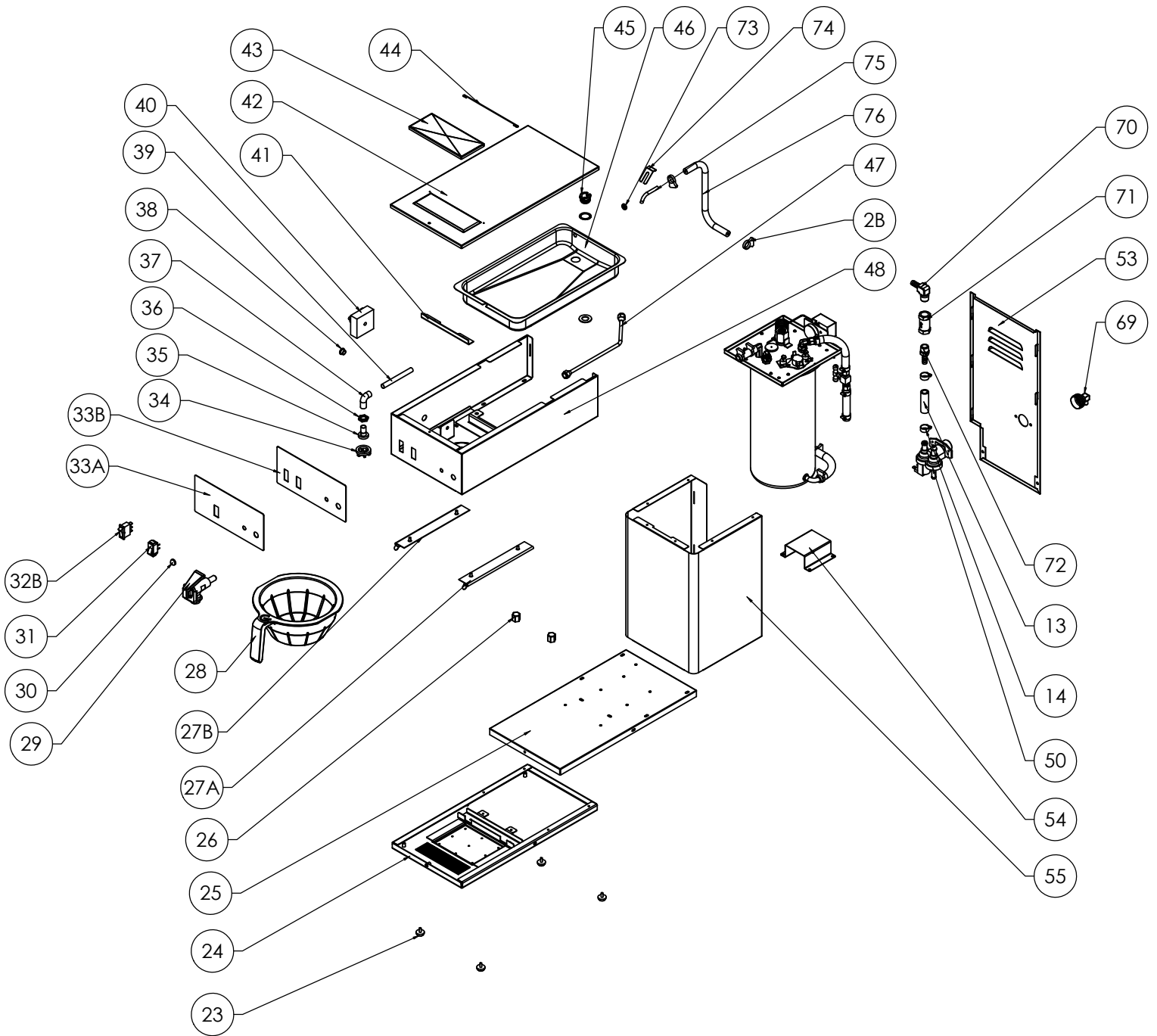

AT-3W/AT-3WE PART LIST

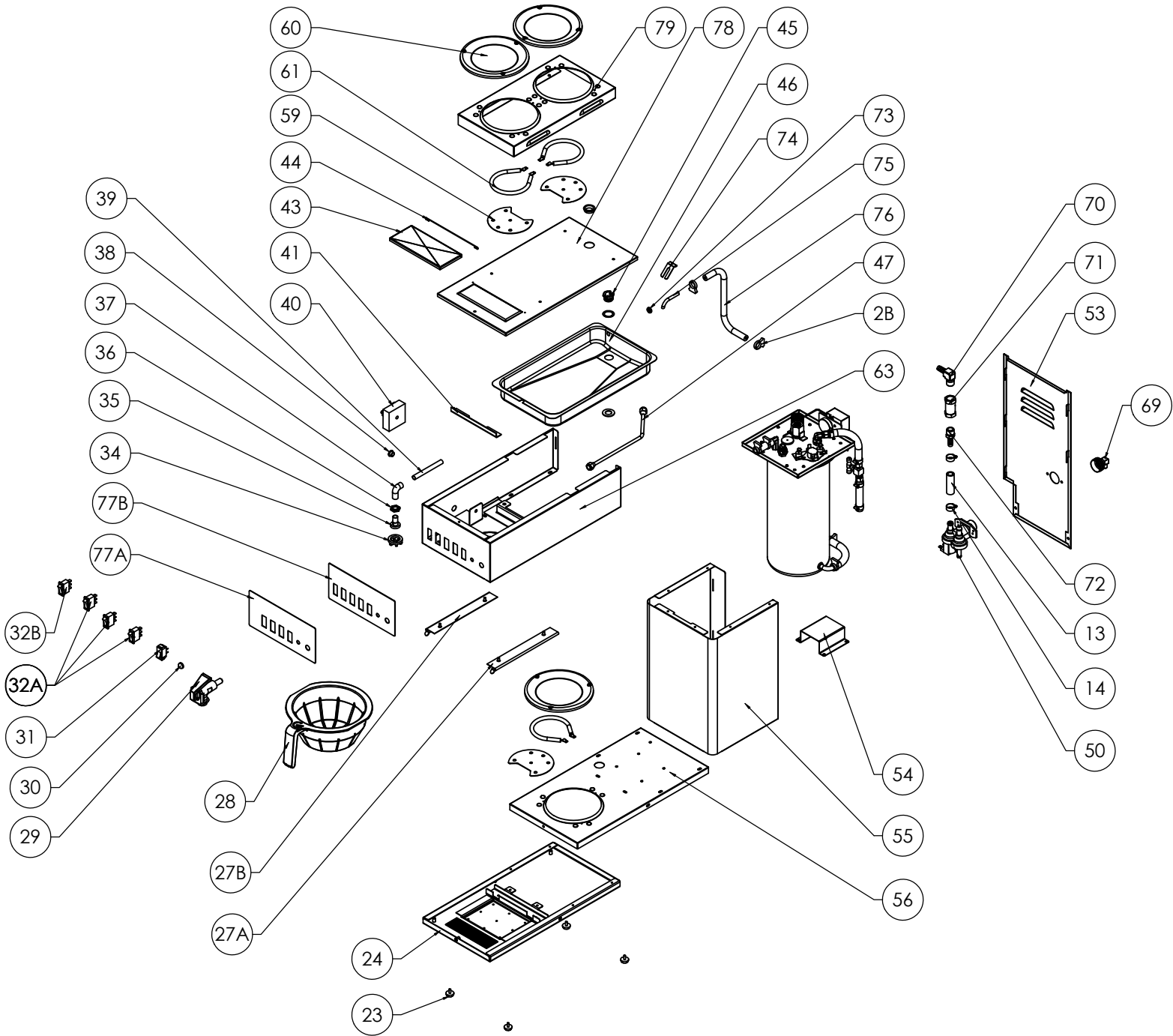

TROUBLESHOOTING GUIDE

Problem	Possible Source	Check	Solution
No Hot Water	<ol style="list-style-type: none"> 1. Tank heater 2. Hi-limit thermostat or main thermostat 	<ol style="list-style-type: none"> 1. Check the voltage at the tank heater terminals. Voltage should be 120V (230V for E models). Check serial tag for proper voltage. 2. Check the voltage between the white wire on the tank heater terminal and the incoming terminal (black wire) on the hi-limit thermostat, then the outgoing (black wire) terminal on the hi-limit thermostat. 	<ol style="list-style-type: none"> 1. (A) If correct voltage is present at the tank heater terminals and water is not being heated, replace tank heater. (B) If voltage is not present at tank heater terminals, refer to step 2. (C) If incorrect voltage is present at tank heater terminals, check voltage at outlet. 2. (A) If voltage is present on incoming terminal on the hi-limit thermostat but not on the outgoing terminal, replace hi-limit thermostat. (B) Check voltage between black and white wire on receptacle. If voltage is not present check outlet or circuit breaker. (C) If voltage is not present on incoming terminal of hi-limit thermostat, replace main thermostat.
Steaming or Spitting Around Funnel	<ol style="list-style-type: none"> 1. Main thermostat 2. High altitude 	<ol style="list-style-type: none"> 1. Thermostat contact stuck or out of calibration 2. For altitude above 5,000 feet (1,500m) 	<ol style="list-style-type: none"> 1. (A) Adjust thermostat to lower temperature setting. (B) Thermostat should be calibrated or replaced.
Dripping	<ol style="list-style-type: none"> 1. Not siphoning properly 2. Leaky fill valve 	<ol style="list-style-type: none"> 1. Water should flow from sprayhead freely 2. Turn off water supply to see if dripping stops 	<ol style="list-style-type: none"> 1. (A) Clean sprayhead holes (B) Check tightness of sprayhead tube. (C) Check brass elbow in tank for debris 2. Replace or repair inlet valve as needed
Dry Coffee Remaining on Brew Basket	<ol style="list-style-type: none"> 1. Filters 2. Not siphoning properly 3. Improper loading of brew basket 	<ol style="list-style-type: none"> 1. Are correct filters being used 2. Refer to "dripping" step 1 3. Filter and coffee in brew basket 	<ol style="list-style-type: none"> 1. Use correct filter 2. Refer to "dripping" step 1 3. Filter should be centered in brew basket and coffee bed should be level.
Warmer Station	<ol style="list-style-type: none"> 1. Warmer - defective 2. Warmer On/Off switch 3. Bad harness 	<ol style="list-style-type: none"> 1. Voltage at warmer terminals should be 120V (230V for E models). 2. If voltage is not present on warmer terminals, check continuity of switch 3. Check connections between harness and switch, and between switch and warmer. 	<ol style="list-style-type: none"> 1. If voltage is present on terminals, but warmer is not heating, replace warmer. 2. If switch does not make and break continuity when turned on and off, replace switch. 3. All connections should be tight.
Overflowing	<ol style="list-style-type: none"> 1. Receiving container not completely empty at start of brew cycle. 2. Not siphoning properly 3. Adjust timer 	<ol style="list-style-type: none"> 1. Operating instructions 2. Refer to "dripping" step 1. 3. Check valve on-time with watch 	<ol style="list-style-type: none"> 1. Always start brew cycle with empty container. 2. Refer to "dripping" step 1. 3. Refer to "Brew Volume Adjustment" section
Low Pot Level	<ol style="list-style-type: none"> 1. Adjust timer 	<ol style="list-style-type: none"> 1. Check valve on-time with watch 	<ol style="list-style-type: none"> 1. Refer to "Brew Volume Adjustment" section
Excessively Long Brew Times	<ol style="list-style-type: none"> 1. Lime scale build-up 	<ol style="list-style-type: none"> 1. Remove spray head deflector and check nozzle. 	<ol style="list-style-type: none"> 1. Delime machine.
Little or No Water From Faucet	<ol style="list-style-type: none"> 1. Lime scale build-up 2. Clogged inlet valve 	<ol style="list-style-type: none"> Be sure water is turned on. 	<ol style="list-style-type: none"> 1. Delime heat exchanger. 2. Replace or repair inlet valve.

If you still need help, call an authorized dealer in your area or Grindmaster Corporation's Technical Service Department. You can reach Technical Service at (502) 425-4776 or (800) 695-4500 (USA and Canada only) Monday - Friday, 8:00 AM - 8:00 PM EST.

Please have the model and serial number ready so that accurate information can be given.

Prior authorization must be obtained from Grindmaster Corporation's Technical Service Department for all warranty claims.

COMPONENT REPLACEMENT INSTRUCTIONS



WARNING - Disconnect power before servicing. Risk of electric shock.

These steps apply to replacement of TANK, TANK HEATER, and HI-LIMIT or MAIN THERMOSTAT

1. Remove brewer lid. Disconnect electrical connectors from upper warmer plate if applicable.
2. Remove pour in basin assembly (receiving pan).
3. Disconnect electrical terminals and hoses as needed.
4. Remove front two screws mounting the tank.
5. Lift tank and lid completely out of tank.
6. Remove two rear screws mounting tank to tank lid.
7. Reverse steps 1-6 to reassemble new tank assembly.

THERMOSTAT, HI-LIMIT

1. Disconnect wires to hi-limit thermostat.
2. Remove two screws and remove thermostat.
3. Check continuity of the new hi limit thermostat before installing.
4. Screw down new t-stat and reconnect wires.
5. Make sure the hi-limit thermostat is securely mounted and that all electrical connections are tight and isolated.

MAIN THERMOSTAT

1. Disconnect wires and remove tank and tank lid assembly.
2. Remove two rear screws mounting tank to tank lid.
3. Remove screws which secure thermostat to tank lid.
4. Loosen thumb nut securing capillary bulb.
5. Remove grommet from top of tank lid by pressing up with thumb and pulling capillary bulb out through hole.
6. Reverse steps 1-5 to reassemble new tank assembly.

TANK HEATING ELEMENT

1. Disconnect wires and remove tank and tank lid assembly.
2. Remove two rear screws mounting tank to tank lid.
3. Loosen thumb nut securing capillary bulb and remove bracket.
4. Remove two brass nuts and remove element.
5. Install new element and washers with nuts secured tightly.
6. Inspect tank lid gasket and replace if necessary.
7. Reverse steps 1-3 to reassemble.

WARMER ELEMENT

1. Remove retaining screws from warmer plate.
2. Lift plate and disconnect leads.
3. Remove nuts and washers holding retaining plate and warmer element to plate.
4. Reverse steps 1-3 to reassemble.

SCHEMATIC WIRING DIAGRAM AT-2W, AT-2WE

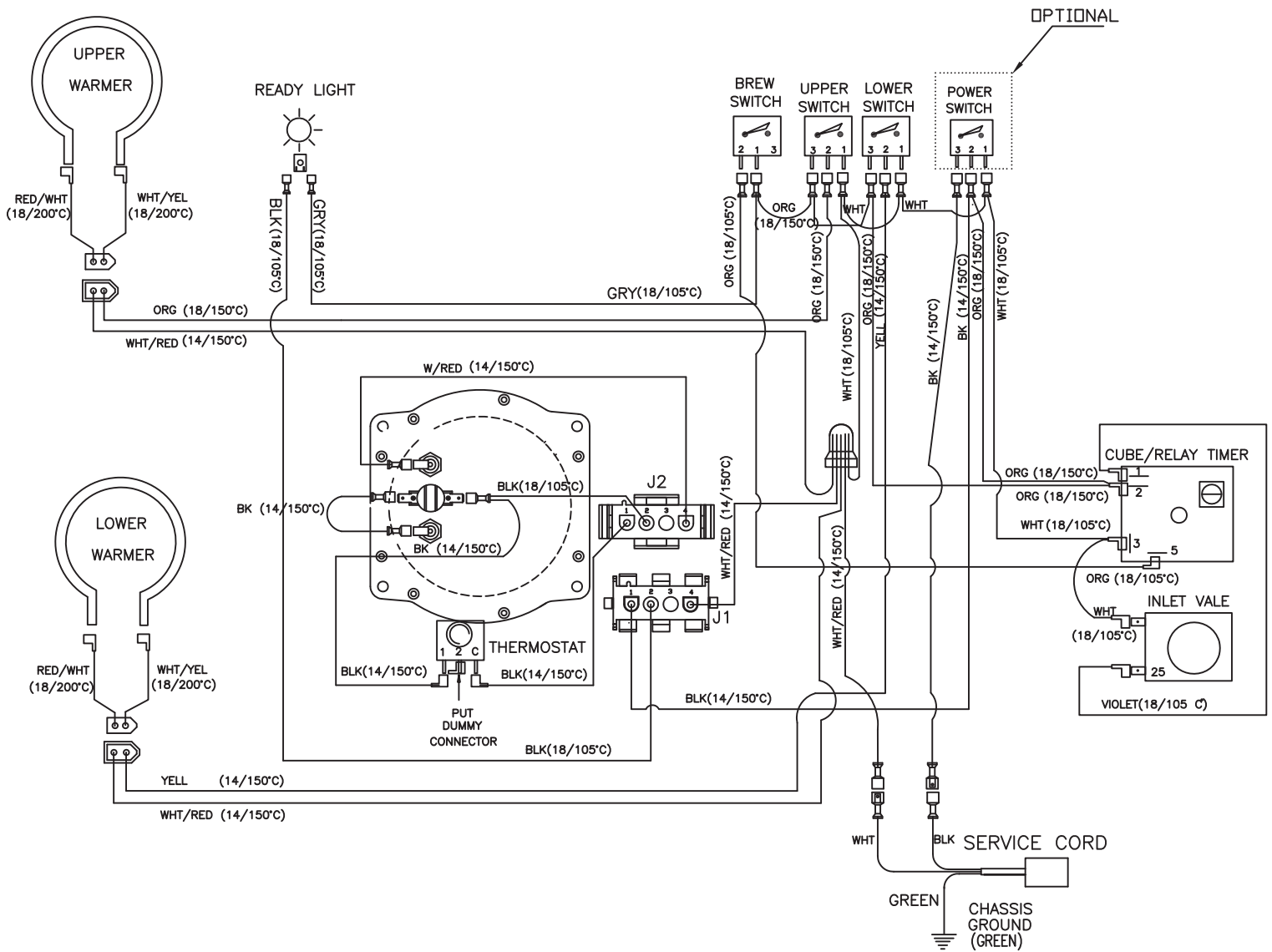

SCHEMATIC WIRING DIAGRAM AT-AP , AT-AP , AT-TC , AT-TCE

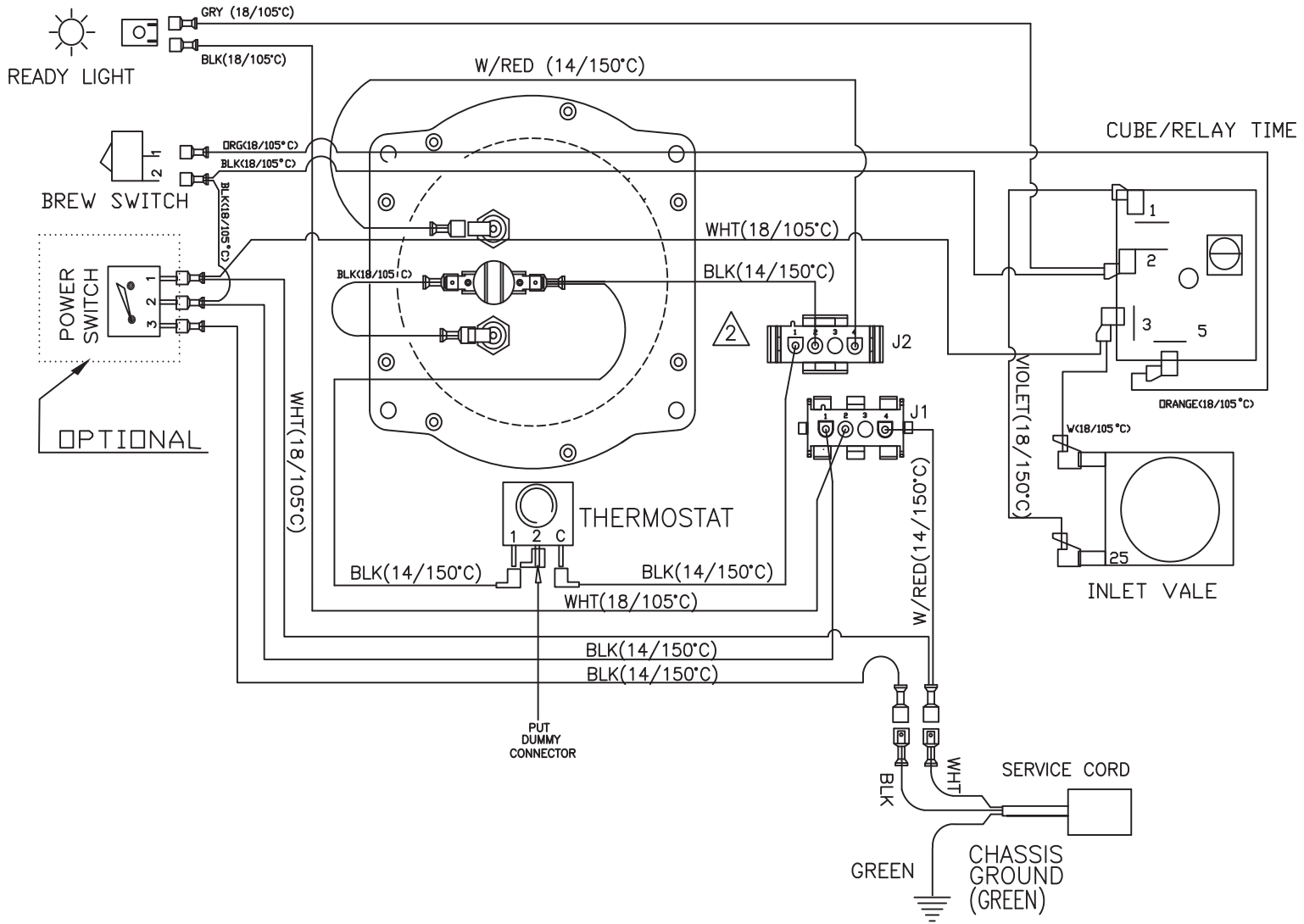

SCHEMATIC WIRING DIAGRAM AT-3WR, AT-3WRE

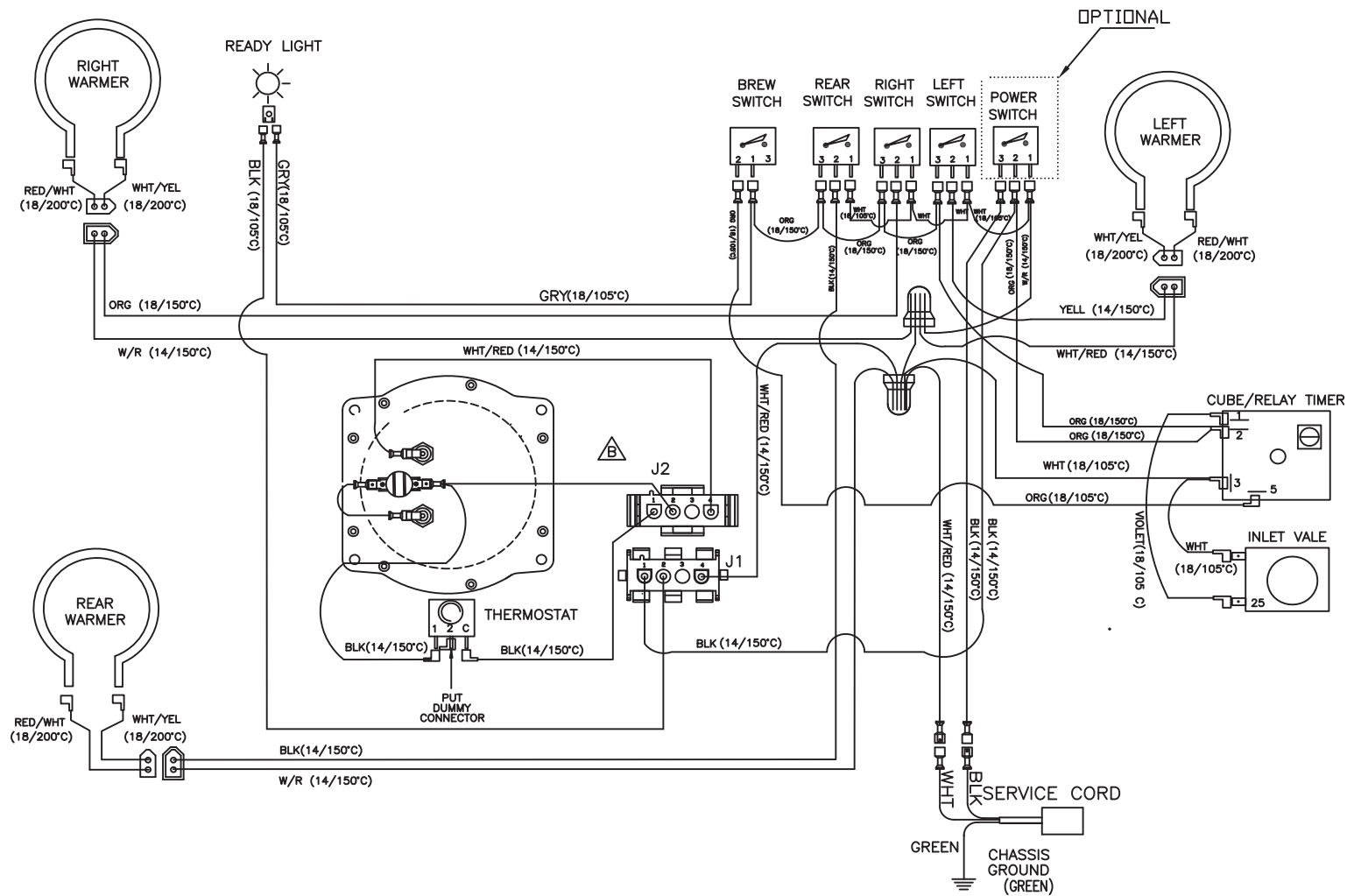

SCHEMATIC WIRING DIAGRAM AT-3W, AT-3WE

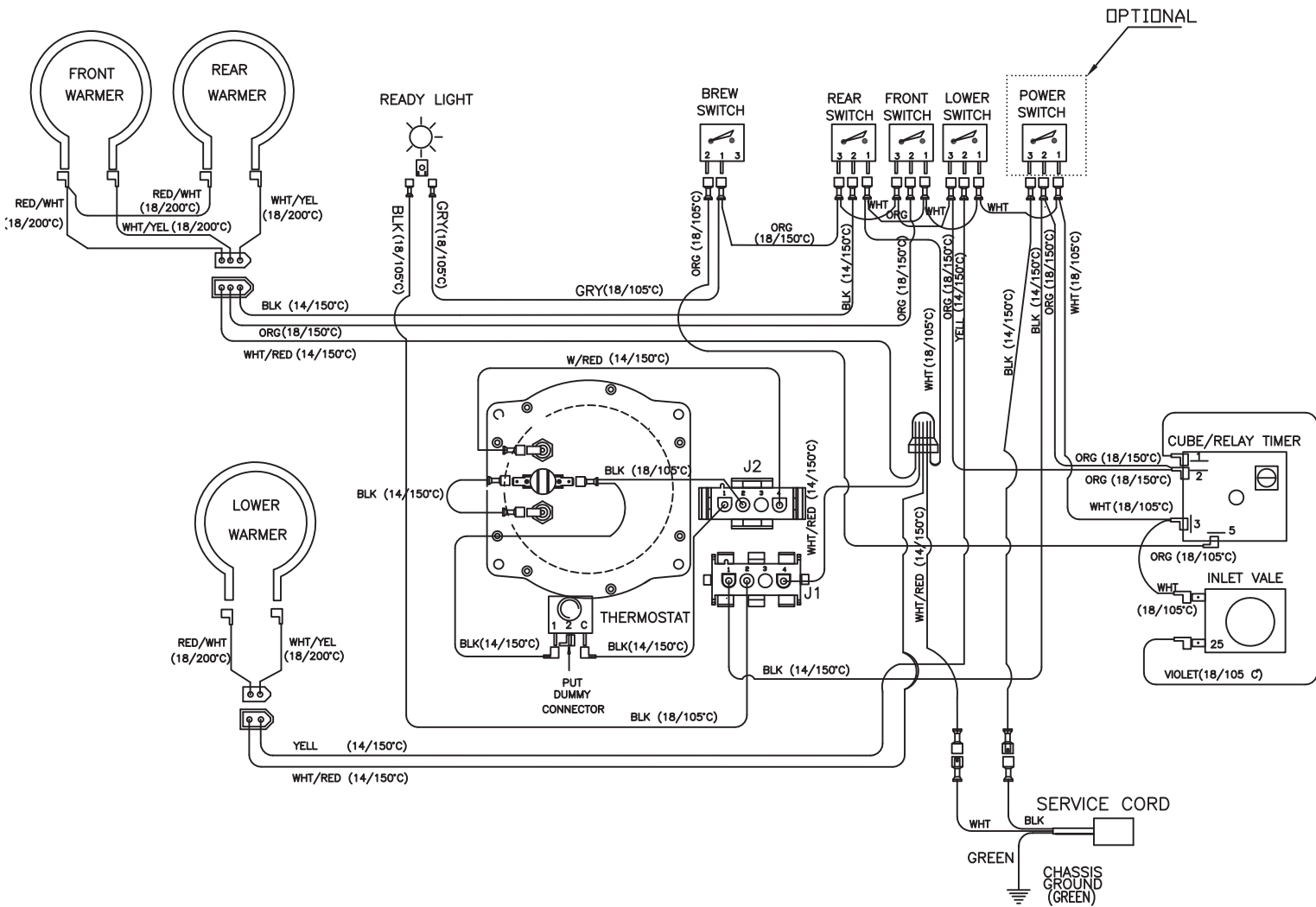



GRINDMASTER™

C O R P O R A T I O N

Grindmaster® Coffee Grinders and Brewers • PrecisionBrew™ Brewing Systems • Espresso® Espresso Machines
Crathco® Hot Beverage Dispensers • Crathco® Cold and Frozen Beverage Dispensers • AMW Coffee and Tea Systems
Tel (502) 425-4776 • Fax (502) 425-4664 • 1-800-695-4500 (USA & Canada only)

P.O. Box 35020 • Louisville, KY 40232 • USA

www.grindmaster.com • email: info@grindmaster.com