



**Cecilware®**

# Operator Manual

## Coffee Urns

FE75N, FE100N, FE200, FE300,  
CL75N, CL100N, CL200 Series

Activate your warranty now at  
<http://gmcw.com/warranty-registration>



**Model FE100N**



**Model FE300**



### Table of Contents

Safety Information.....2	Cleaning.....7
Rough-In Drawings .....3	Adjustments .....7
Electrical Specifications.....5	Maintenance .....8
Installation.....5	Parts Diagram.....12
Priming .....6	Parts List.....14
Operation .....6	Wiring Diagram.....16

Thank you for purchasing this quality urn. For your safety and the safety of others, read all warnings and the operator manual before installing or using the product. Properly instruct all operators. Keep training records. For future reference, record serial number here:

**Grindmaster-Cecilware**

4003 Collins Lane, Louisville, KY 40245 USA  
Phone: 502.425.4776 Toll Free: 800.695.4500  
Fax: 502.425.4664  
Web: [gmcw.com](http://gmcw.com) Email: [info@gmcw.com](mailto:info@gmcw.com)

Grindmaster-Cecilware provides the industry's BEST warranty. Visit [gmcw.com](http://gmcw.com) for warranty terms and conditions.



## Safety Information

### Important Safety Information



This is the safety alert symbol. It is used to alert you to potential personal injury hazards. Obey all safety messages that follow this symbol to avoid possible injury or death.

For your safety and the safety of others, read all warnings and the operator manual before installing or using the product.

**DANGER:** This term warns the user of imminent hazard that will result in serious injury or death.

**WARNING:** This term refers to a potential hazard or unsafe practice, which could result in serious injury or death.

**CAUTION:** This term refers to a potential hazard or unsafe practice, which could result in minor or moderate injury.

**NOTICE:** This term refers to information that needs special attention or must be fully understood.

### **WARNING**

To reduce risk of electrical shock, do not remove or open cover. No user-serviceable parts inside. Repair should be done by authorized service personnel only.

The appliance is not intended for outdoor use.

Do not clean with pressurized water or use in an area where pressurized water may be used.

Cleaning and maintenance shall be made only by properly trained persons with supervision.

This appliance is not intended for use by persons with reduced physical, sensory, or mental capabilities, or lack of experience and knowledge, unless they have been given supervision or instruction concerning use of the appliance by a person responsible for their safety.

Children should be supervised to ensure that they do not play with the appliance.

Do not alter or deform the power cord or plug in any way! Altering or deforming the plug may cause electrical shock, damage unit and will void warranty.

To reduce risk of explosion or fire, do not use near combustibles.

### **CAUTION**

For safe and proper operation, the appliance must be placed in a stable, vertical position.

To reduce risk of serious burns or scalding, do not place hand or other body parts under dispenser or container while product is brewing.

Always unplug unit from power supply before servicing.

Hot liquid in brew basket could cause burns. Remove with care.

Surfaces are hot and can cause burns.

### **NOTICE**

Use only on a circuit that is properly protected and capable of the rated load.

Electronically ground the chassis.

Follow national and local electrical codes.

Do not use extension cord.

This equipment must be installed in compliance with applicable Federal, State, and/or Local plumbing codes having jurisdiction. This product requires an approved back flow prevention water device, such as a double check valve, to be installed between the machine and the water supply.

## Rough-In Drawings

**FE75N Single 3 Gallon Urn, Adjustable By-pass, Automatic Agitator, and Solid State Timer**

**CL75N Single 3 Gallon Urn, Adjustable By-pass, Push-Button Agitator, and Electro-Mechanical Timer**

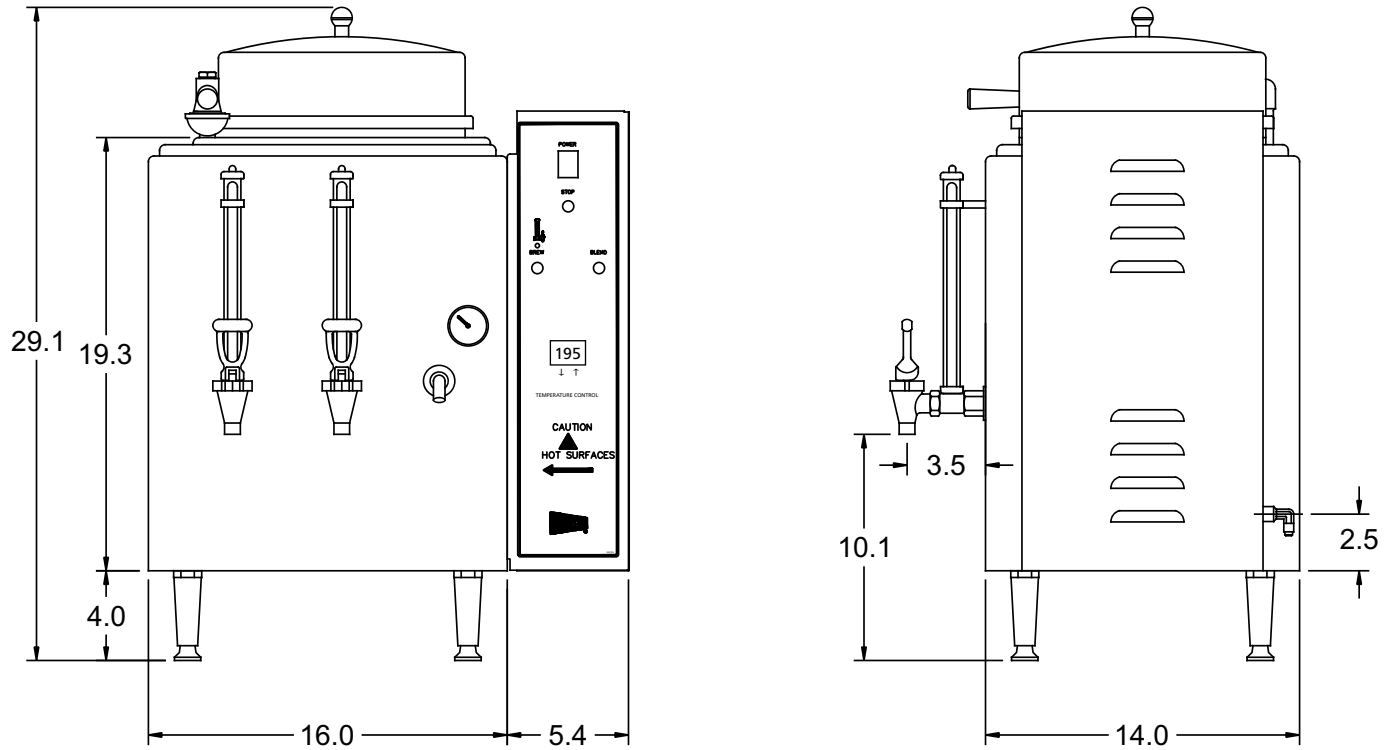

**FE100N Twin 3 Gallon Urn, Adjustable By-pass, Automatic Agitator, and Solid State Timer**

**CL100N Twin 3 Gallon Urn, Adjustable By-pass, Push-Button Agitator, and Electro-Mechanical Timer**

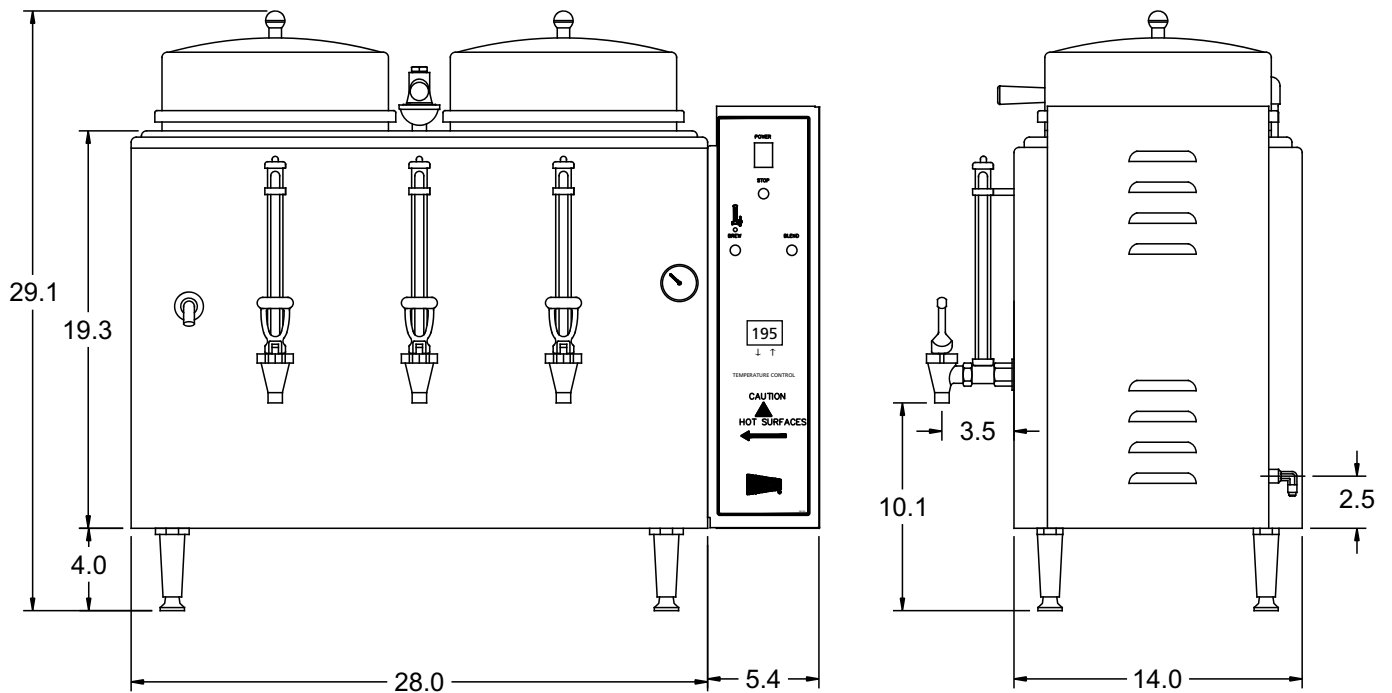

## Rough-In Drawings (continued)

**FE200 Single 6 Gallon Urn, Adjustable By-pass, Automatic Agitator, and Solid State Timer**

**CL200 Single 6 Gallon Urn, Adjustable By-pass, Push-Button Agitator, and Electro-Mechanical Timer**

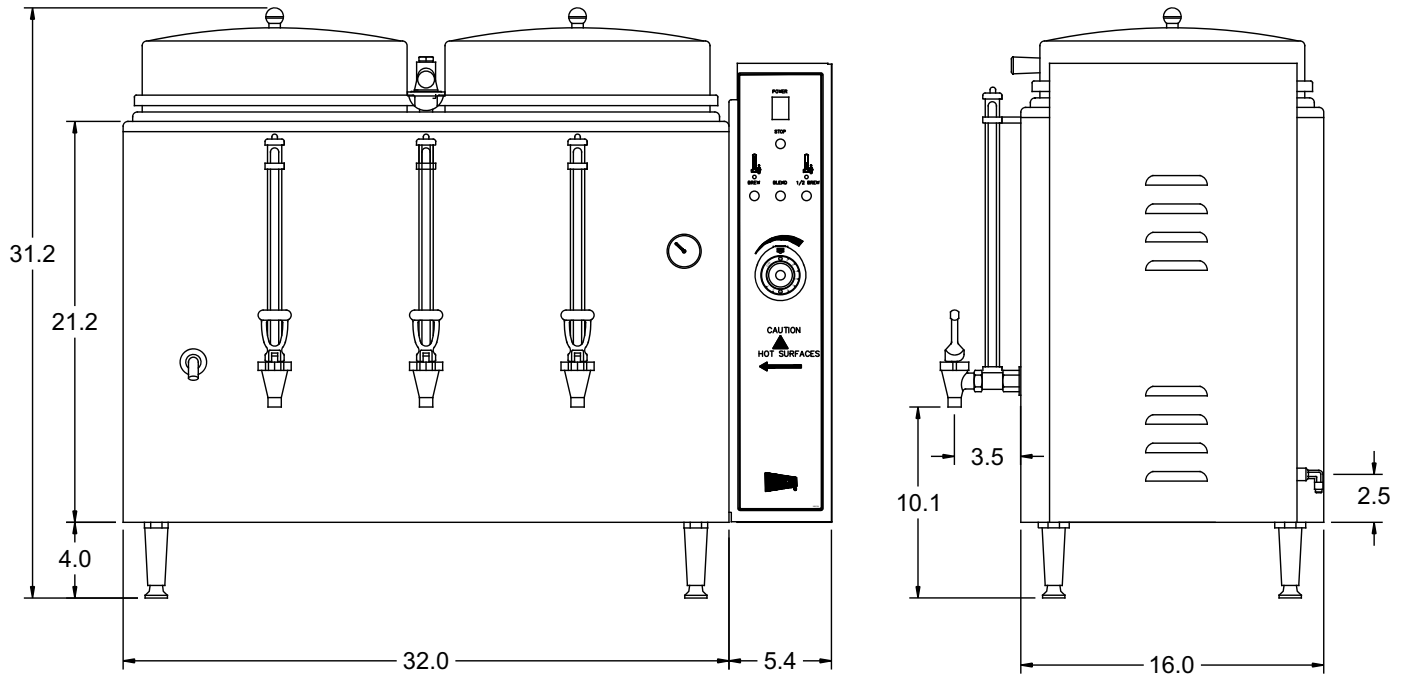

**FE300 Twin 10 Gallon Urn, Adjustable By-pass, Automatic Agitator, and Solid State Timer**

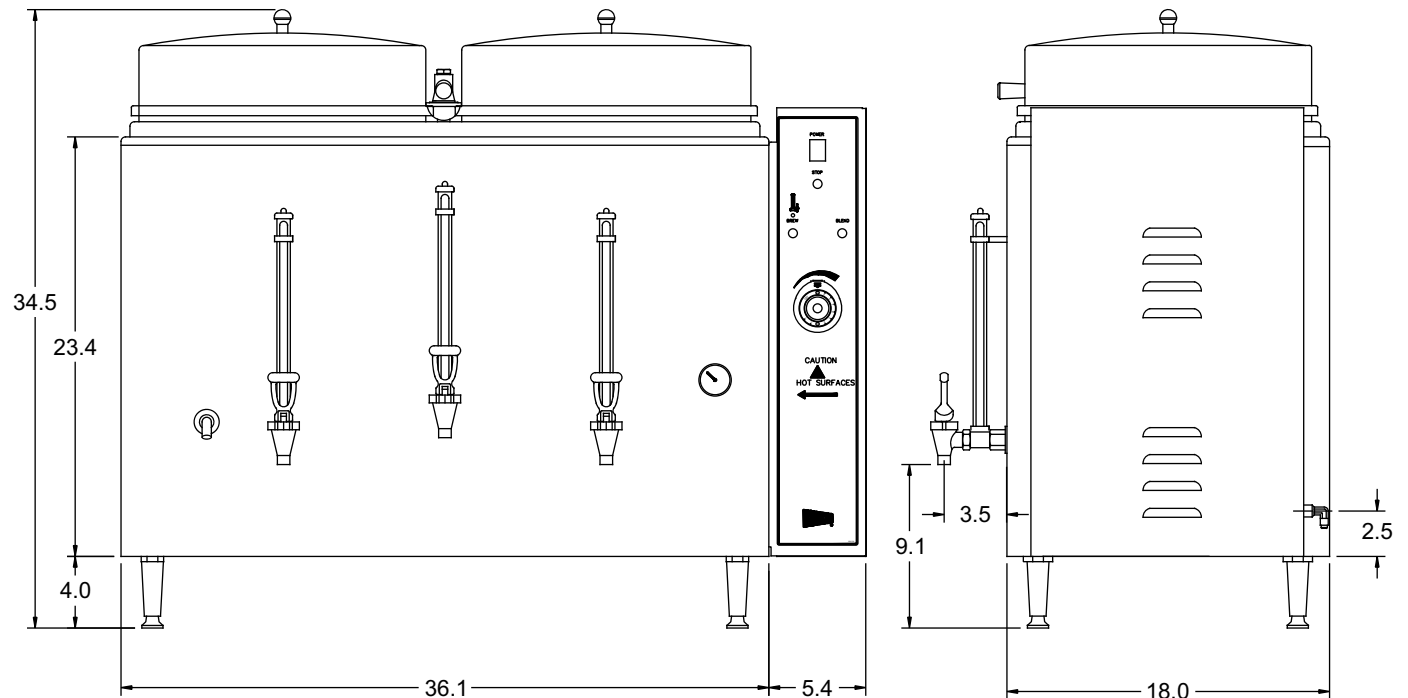

## Electrical Specifications

Information below provided for US models only. Check rating marking on urn nameplate. Consult factory for export model information.

VOLTS	KILOWATTS		AMPS	
	1 PHASE	3 PHASE	1 PHASE 3 WIRE	3 PHASE 4 WIRE
120/240	7	6	29	15
120/208	5.3	4.5	26	12
120/240	6	8	34	20
120/208	8	6	29	17
120/240	7	8	29	20
120/208	5.3	6	26	17
120/240	10	10	42	24
120/208	7.5	7.5	38	22
120/240	-	15	-	37
120/208	-	11.3	-	33

**Recommended Wire Size For Field-Wiring Urns** US models only. Consult factory for export model information..

MODEL	WIRE SIZE	
	1 PHASE	3 PHASE
FE75N, CL75N, CL100N	(2) 10 AWG + GND	(3) 10 AWG + GND
FE100-N	(2) 8 AWG + GND	(3) 8 AWG + GND
FE200-N, CL200-N	(2) 6 AWG + GND	(3) 8 AWG + GND
FE300-N	-	(3) 10 AWG + GND

Neutral and Ground Wires # 14 AWG min.

Note: Field wiring must be suitable for 75° C. Use copper wire only for power supply connections.

GROUNDING: ON ALL URNS, CONNECT A GROUND WIRE TO GROUNDING LUG TO COMPLY WITH LOCAL ELECTRICAL CODES (14 AWG MIN. 75° C)

## Installation

### Unpacking Instructions

Carefully unpack the machine and inspect immediately for shipping damage. The packaging may contain unattached parts. Your machine was shipped in a carton designed to give it maximum protection in normal handling. It was thoroughly inspected before leaving the factory. In case of damage, contact the shipper, not Grindmaster-Cecilware.

**NOTICE:** The person installing this appliance is responsible for ensuring that electric and water connections meet the requirements of the national electric code, national plumbing code, and any local ordinances.

See **Rough-in Drawings** for approximate dimensions and locations of electric and water input.

### Mechanical Installation

**⚠ WARNING: ELECTRIC SHOCK HAZARD!**  
Installation of this appliance should be performed by qualified service personnel only. Improper installation could result in electrocution.

### ⚠ CAUTION

These urns are heavy pieces of equipment. It is recommended that moving or lifting the unit be done by two people to avoid injury.

**NOTICE: Do not turn thermostat on until all installation instructions have been followed.**

1. Inspect unit to see if any damage occurred in shipment.
2. Remove the urn from the packing material. The four legs, faucets, and vent cap drain are packed separately with urn.
3. Install legs by tilting urn on its side and screwing legs into urn leg supports until hand tight.
4. Carefully right unit and install in its permanent location, being sure to leave at least 6" on right side of urn for access to controls. Position urn so that the faucets drip into a drip trough or drain receptacle of some type.
5. Level urn by adjusting legs. Then attach faucets and install vent cap drain.
6. Cover(s) are shipped with knob(s) on inside to prevent damage. Simply unscrew and reverse.

## Installation (continued)

### **▲ WARNING: ELECTRIC SHOCK HAZARD!**

Installation of this appliance should be performed by qualified service personnel only. Improper installation could result in electrocution.

### **Water Hook-up**

**NOTICE:** This equipment must be installed in compliance with applicable Federal, State, and/or Local plumbing codes having jurisdiction. This product requires an approved back flow prevention water device, such as a double check valve, to be installed between the machine and the water supply. Incoming pressure should be greater than 30 psi and not more than 70 psi.

Urn should be connected to cold water supply

1. The automatic coffee urn is equipped with a ¼" Flare water inlet fitting which is located on the back of the unit.
2. Provide shut-off valve and union in supply line near urn.
3. Minimum inlet pressure at urn should be 30 PSI.
4. Maximum inlet pressure recommended at 70 PSI.
5. Copper flex tubing should be used for valve connections.
6. To ensure pressure at the urn of at least 30 PSI, use 3/8" OD tubing for short runs, 1/2" OD tubing for longer runs, and larger size tubing for unusually long runs. Be sure other appliances will not reduce water pressure excessively.
7. Turn on the water supply line and check for leaks.

**NOTE:** For the best tasting coffee, add a filtering system to the water supply line to eliminate any taste and/or odor from the water.

**NOTE:** In areas with extremely hard water, a water softener must be installed in order to prevent mineral deposits that could result in malfunctioning of the equipment and in order not to void the warranty.

### **Electrical Hook-up**

### **▲ WARNING: ELECTROCUTION HAZARD!**

Never use the ground conductor as a neutral. This could cause electrocution.

**NOTICE:** This equipment must be installed in compliance with applicable Federal, State and/or Local electrical codes having jurisdiction. Do not use extension cords. Make sure that the outlet the urn plugs into is grounded.

1. Check rating marking on urn nameplate to be sure electric lines match voltage, phase, and amperage requirements of urn. Select the proper cord and cord grip for electrical rating of the urn.
2. **Urn body MUST be grounded.** A grounding terminal is provided for this purpose.
3. Use only copper wire to connect this urn.

## Priming

NOTE: THERMOSTAT MUST BE IN THE "OFF" POSITION.

1. Open water supply line valve to urn.
2. Turn on or plug in the power supply to the urn. Water compartment will begin to fill automatically. Do not power up the urn when the water line is off.
3. Wait until water is visible in center gauge glass (left-hand gauge glass on 3-gallon single urns). Then turn thermostat knob to 10; thermostat pilot light shows heater is on. Urn jacket will continue to fill automatically until water reaches the proper level.
4. When indicator on dial thermometer approaches the "W" in BREW zone, 195°F (92°C), urn is ready to brew coffee.
5. In high altitude locations (over 5000 ft. above sea level), thermostat may have to be lowered to prevent boiling.
6. Brew and discard at least one batch of water into each liner. Check that the fill level is correct. See the **Adjustments** section if changes are needed.

## Operation

### **▲ CAUTION: BURN HAZARD**

Water used for brewing coffee is very hot. Use caution when brewing, pouring, or transporting coffee. Accidental spills may result in severe burns. Use caution when disposing grounds.

1. Place filter paper in brew basket with designated amount of coffee grounds. Coffee experts recommend from 6 to 10 ounces of coffee per gallon of water. Use fresh urn grind or drip grind coffee spread evenly on filter for proper extraction. Make certain you have a level bed of coffee. Consult your coffee supplier for exact brewing specifications.
2. Water should be heated to 195°F (92°C) before brewing coffee.
3. While brewing, leave cover on urn to preserve aroma and prevent excessive steaming. Total contact time for urn grind should be approximately 4-6 minutes. When the brew is finished, allow one to two minutes for the coffee to drip from the basket.
4. When the drip period is complete, center the spray arm and remove the basket to throw away the grounds. Replace the liner cover to keep the coffee hot. Never pour coffee back through spent grounds.
  - Urns with automatic agitator (FE series), blend coffee automatically at end of brewing cycle. Press and hold agitator BLEND switch for additional blending.
  - If urn has a manual agitator (CL series), press and hold agitator BLEND switch for 20 seconds after brewing cycle to blend coffee.
5. Coffee is ready to serve.
6. Hold coffee at 185°-190°F (85°-88°C) (about 8 on thermostat). Brewed coffee should not be held for longer than one (1) hour and should never be reheated.

## Cleaning

### ▲ CAUTION: BURN HAZARD

The urn surfaces and water inside jacket are very hot. Use caution when cleaning this urn to prevent burns.

**NOTICE:** All sanitizing agents in the food zone must comply with 21 CFR 178.1010. Sanitize all food dispensing units periodically. All parts to be sanitized must be cleaned first. Cleaning and sanitizing frequency must follow state and local health department regulations.

**NOTICE:** Do not use cleansers, bleach liquids, powders, or any other substance containing chlorine. These products promote corrosion and will pit the stainless steel. USE OF THESE PRODUCTS WILL VOID THE WARRANTY.

#### After Each Brew:

1. Dispose of grounds and rinse brew basket.

#### Every Day:

1. Drain the urn; then run a brew cycle of hot water. After spraying hot water into the liner, thoroughly brush the liner with a long handled brush.
2. Drain the water and repeat step one. Run another brew cycle. Brush the liner and drain.
3. Wash the wire brew baskets with urn cleaner and rinse thoroughly.

#### Weekly or Bi-Weekly, Depending on Use:

1. Fill the urn liners with several gallons of hot water.
2. Pour into the liner the recommended concentration of urn cleaning compound. Set the thermostat to high (NO. 10) and then run a brew cycle of hot water.
3. Allow solution to remain in the liner for approximately 30 minutes.
4. Scrub the inside of both the liner and the cover with a long handled brush.
5. Drain the cleaning solution from the liner. Rinse by running several brew cycles with the sprayhead centered over the liner. Be sure to drain the rinse water between cycles.

### ▲ CAUTION: BURN HAZARD

Never remove the faucet when the liner has water or coffee in it. Switch OFF the power to the unit at the circuit breaker. Turn off the water line running to the urn.

6. Thoroughly clean the faucets.
7. Use a long, thin gauge glass brush to clean the coffee gauge glass. Use the same brush to clean the fitting at the bottom of the liner and the pipe connected to the coffee faucet.
8. Reassemble faucets. Fill the liners with hot water and drain until the liner and all parts are completely rinsed.

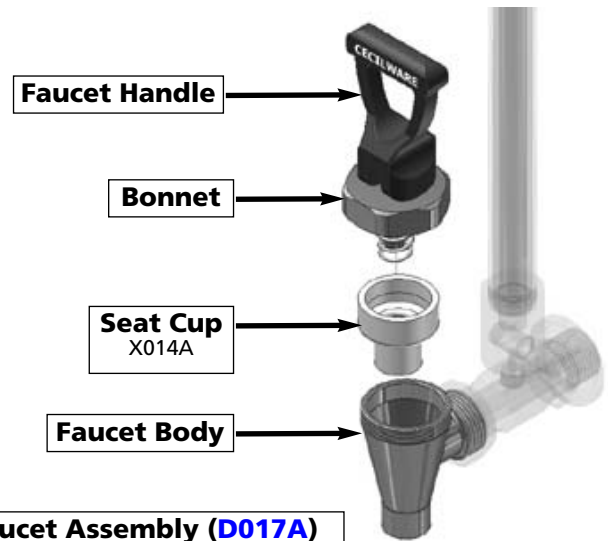

## Adjustments

### ▲ WARNING: SHOCK AND BURN HAZARD

To prevent electric shock and burn hazard, all tasks described in this section are to be performed by a trained and qualified service technician.

#### Thermostat Adjustment

The Thermostat is factory set for proper dispense temperature of 200°F ± 3°F with the control knob set to the maximum clockwise position. If field adjustments are needed proceed as follows:

- To DECREASE temperature, turn the control knob slightly in the COUNTERCLOCKWISE direction.
- To INCREASE the water temperature -
  1. With the Thermostat Knob to its maximum clockwise position, remove the knob and locate the slotted adjustment screw inside the hollow thermostat shaft.
  2. Using a narrow-bladed screwdriver, engage slotted adjustment screw and turn it 1/4 turn slowly counter-clockwise.

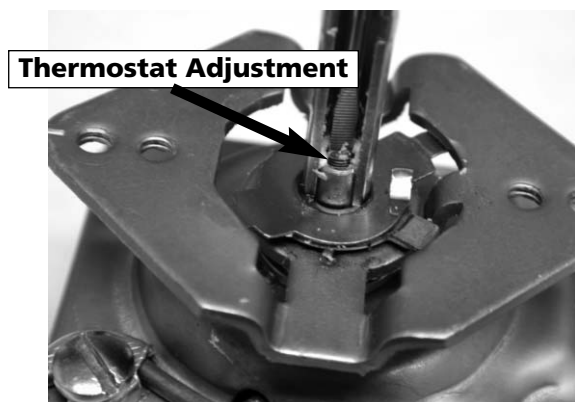

(continued next page)

## Adjustments (continued)

### ⚠ WARNING: SHOCK AND BURN HAZARD

To prevent electric shock and burn hazard, all tasks described in this section are to be performed by a trained and qualified service technician.

### ⚠ WARNING: SHOCK HAZARD

Disconnect power before attempting any electrical repairs.

### Thermostat Adjustment (continued)

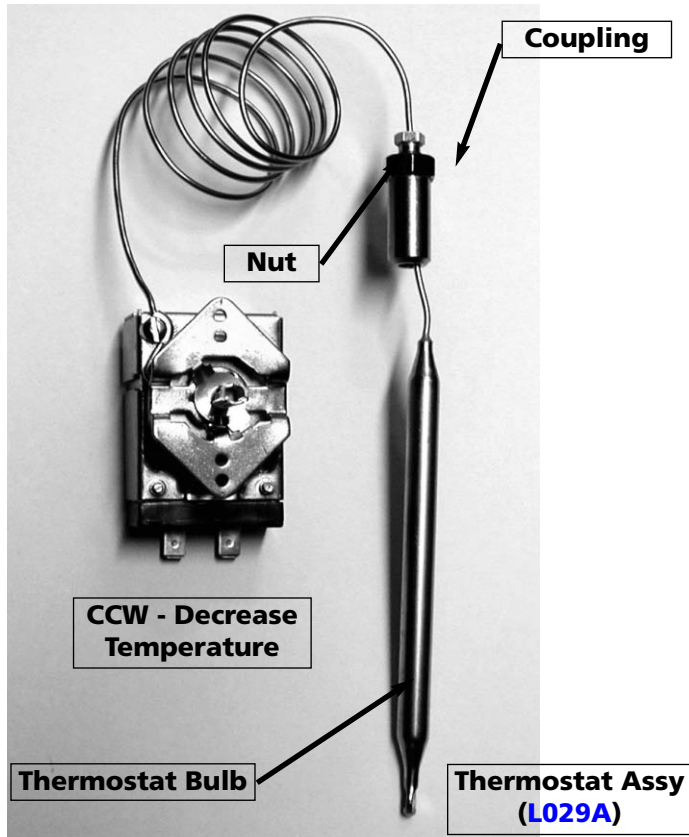

3. Allow a few minutes for the temperature to reach set level. The Heater Light will go ON, indicating the heating element is activated, wait for it to go OFF, indicating that the water has reached new set temperature.
4. Take a temperature reading and repeat if necessary.

### Digital Display Temperature Adjustment

1. Press up and down arrows until desired temperature is displayed.

### Solid-State Timer Adjustment (FE models)

A factory pre-set electronic solid-state timer controls the volume of water for each brew cycle. If more or less water is desired, follow these instructions:

1. Turn knob of timer clockwise to increase volume of water or counterclockwise to decrease it.
2. Run through a complete brew cycle after each adjustment. Since timer cannot be readjusted in mid-cycle, simply push cycle stop switch at bottom

right of side box if water gets too high.

3. If maximum setting of timer fails to deliver enough water, check water pump and spray head and follow instructions under **Maintenance**.

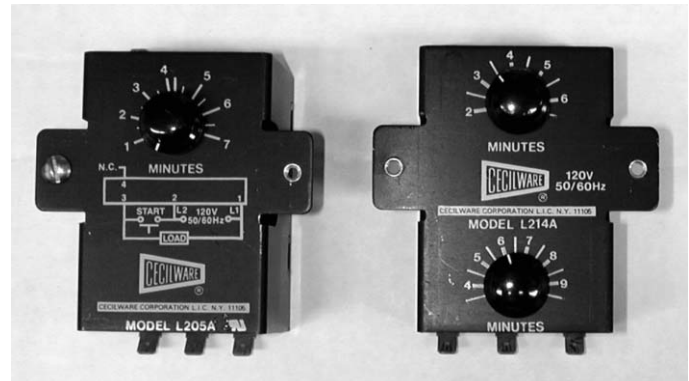

**Single Timer**  
(120V - L205A)  
(240V - L210A)

**Dual Timer**  
(120V - L214A)  
(240V - L216A)

### Mechanical Timer Adjustment (CL models)

The factory pre-set mechanical timer can be adjusted for more or less water by following these instructions:

1. Remove timer knob and loosen lock nut holding stop pin.
2. To increase volume of water, rotate stop pin clockwise.
3. To decrease, rotate counterclockwise. Tighten lock nut and replace knob.

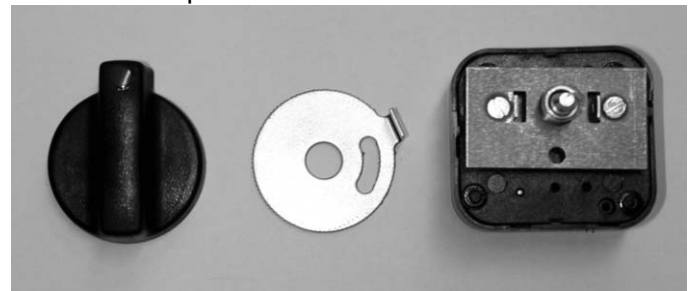

**Manual Timer**  
(L154A)

### Spray Arm By-Pass Adjustment (All Urns)

Adjustable bypass allows proper brew extraction even with variations caused by soft or treated water. If bypass requires adjustment to correct for local water conditions, proceed as follows:

1. Position spray head over center of coffee liner and press BREW switch.
2. Turn by-pass adjustment screw clockwise to decrease by-pass flow (for stronger coffee) or counter-clockwise to increase by-pass flow (for weaker coffee).
3. At end of brewing cycle, note volume of water in coffee liner. Readjust timer if necessary to obtain the correct volume of water.

## Adjustments (continued)

### ▲ WARNING: SHOCK AND BURN HAZARD

To prevent electric shock and burn hazard, all tasks described in this section are to be performed by a trained and qualified service technician.

### ▲ WARNING: SHOCK HAZARD

Disconnect power before attempting any electrical repairs.

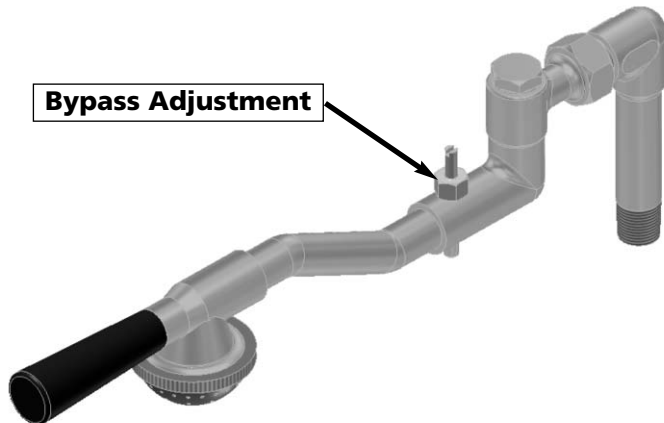

## Maintenance

### ▲ WARNING: SHOCK AND BURN HAZARD

To prevent electric shock and burn hazard, all tasks described in this section are to be performed by a trained and qualified service technician.

### ▲ WARNING: SHOCK HAZARD

Disconnect power before attempting any electrical repairs.

The rest of this manual contains information to aid the service technician who is maintaining this equipment. This section has information on performing common service tasks.

If you still need help after reading this section, call Grindmaster-Cecilware Technical Service Department, (502) 425-4776 or (800) 695-4500 (USA & Canada only) (Monday through Friday 8 AM - 6 PM EST). Please have the model and serial number ready so that accurate information can be given.

Prior authorization must be obtained from Grindmaster-Cecilware for all warranty claims.

**Grindmaster-Cecilware provides the industry's BEST warranty. Visit our website at [gmcw.com](http://gmcw.com) for warranty terms and conditions.**

### To Move the Urn

The urn must be completely drained (jacket and liners) and allowed to cool prior to moving this urn.

### Spray Arm Assembly

The spray head system was designed to facilitate easier

cleaning and maintenance. The swivel valve has a large flow opening and the spray head cap is equipped with a stainless steel disc, used to control the flow of water. When ordering replacement parts, be sure to order the correct disc and spray cap for each urn, as shown in **Parts Diagram** Illustration.

- To prevent lime buildup, especially in hard water areas, remove and clean spray head cap and spray head disc frequently.
- To clean swivel valve loosen nut and remove spray arm assembly from urn.
- Remove sediment by inserting a pipe cleaner through small hole in valve.
- If maximum setting of timer fails to deliver enough water, check water pump.

### If Water Fails To Heat

1. Check line fuse or circuit breaker. Replace or reset if necessary.
2. Make sure thermostat is in ON position. If thermostat pilot light does not come on, replace thermostat. (Refer to instructions below.) If pilot light is on, measure continuity between terminals 1 and 2 of thermostat, and between terminals 3 and 4. If a resistance is measured, replace thermostat.
3. If thermostat is okay, check wiring and repair if necessary: if wiring is okay, check heater resistance; if high or infinite, replace as follows:

### Replacing Heater

1. Shut off power and disconnect water supply at elbow. Drain urn.
2. Remove one coffee gauge glass, faucet, shank, and liner.
3. Tilt urn and disconnect wires to heater.
4. Remove socket head screw and heater flange and lift heater out.
5. Install new heater and reassemble urn.
6. Repeat **Priming** instructions on page 6. **NOTE: DO NOT TURN ON THERMOSTAT UNTIL URN IS PRIMED.**

### Replacing Thermostat (All Models)

Thermostat is located in side box of urn. Lift off side box door to gain access to thermostat; then follow instructions below.

1. Shut off power, disconnect water supply, and drain urn by opening hot water faucet. When faucet stops running you are ready to remove the thermostat bulb.
2. Remove thermostat knob and two screws holding thermostat in place.
3. Disconnect wires from thermostat.
4. Pull out thermostat bulb.
5. Install new thermostat, push in the new thermostat bulb. Tighten compression nut on thermostat fitting to prevent leaking.

(continued next page)

## Maintenance (continued)

### **▲ WARNING: SHOCK AND BURN HAZARD**

To prevent electric shock and burn hazard, all tasks described in this section are to be performed by a trained and qualified service technician.

### **▲ WARNING: SHOCK HAZARD**

Disconnect power before attempting any electrical repairs.

6. Repeat **Priming** instructions on page 6. **NOTE: DO NOT TURN ON THERMOSTAT UNTIL URN IS PRIMED.**

### **If Water from Cold Water Supply Line Does Not Enter Urn**

1. Check water supply to external shut-off valve.
2. Check fuse on rear of side box and replace if necessary.
3. If water supply and fuse are okay, remove fuse and lift off side box door exposing terminal block and electrical wiring.
4. Check dual probe liquid level controller. (See **Component Tests**)

### **If Water Runs Out At Overflow Drain**

1. Make sure urn is level and overflow tube is vertical.
2. Remove fuse from rear of side box.
3. If water continues to flow, solenoid valve is dirty or not seating properly. Replace solenoid as described below.

### **Replacing Solenoid**

1. Shut off water supply, remove fuse, and lift off side box door.
2. Disconnect wires from solenoid: then remove flare nut and unscrew solenoid valve from bracket.
3. Install new solenoid and reinstall fuse and side box door.
4. If necessary, follow **Priming** instructions on page 6.

### **No Water from Spray Head**

1. Check fuse first.
- 2a. For FE urns: Depress BREW switch and release. If switch remains lit, water pump is probably not operating. Lift off side box door and check if fan on water pump is rotating. If not, replace pump as described below.
- 2b. For CL urns: Turn brew timer knob clockwise. Replace timer if it does not go on. If timer goes on but pump doesn't, replace pump.

### **Replacing Water Pump**

1. Shut off water supply and remove fuse. Drain urn to level of water faucet.
2. Lift off side box door and disconnect the two pump wires.
3. Loosen union fittings on pump and remove pump from urn. **NOTICE: If your urn has older style pump with copper connections, it is imperative**

**that you use a counter wrench when removing and installing pump to avoid damaging copper tubing. DO NOT OVERTIGHTEN.**

4. Replace pump and follow **Priming** instructions on page 6.

### **Checking Solid-State Timer (FE Urns)**

1. Press and hold BREW switch for 10 seconds. Brew cycle should start. If water stops coming from spray head as soon as BREW switch is released, timer is not operating. Replace it. (Instructions below.)
2. If no water comes from spray head when BREW switch is pressed, replace switch.

**NOTE:** To check mechanical timer on CL urns, refer to **No Water from Spray Head**.

### **Replacing Solid-State Timer**

1. Remove fuse, lift off side box door, and remove timer from bracket.
2. Carefully note locations of colored wires on timer board and then remove wires.
3. Replace timer and reassemble unit in reverse order.

### **Blending - Automatic Type (FE Urns)**

#### **Operation:**

The agitator pump circuit is programmed to operate immediately after brewing cycle. The circuit pumps air through the coffee gauge glass(es) into the coffee liner(s). The complete cycle takes about 20 seconds. For additional blending, simply press the BLEND switch.

#### **Maintenance:**

- If agitation is not sufficient to blend coffee, check flexible tubing, and glasses and fittings, for possible air leaks. Replace as necessary.
- If agitator pump does not operate immediately after brewing cycle or when BLEND switch is pressed, replace agitator pump or solid state agitator timer.
- If agitator pump comes on immediately after brewing cycle, but does not operate when BLEND switch is pressed, replace BLEND switch.

### **Blending - Manual Type (CL Urns)**

#### **Operation:**

Immediately after brewing cycle, depress BLEND switch and hold for about 20 seconds. Your coffee will be completely blended and ready to serve.

#### **Maintenance:**

- If agitator pump does not operate when BLEND switch is pressed, replace switch, if pump still does not operate, replace pump.

### **Tank Control Board Error Codes**

ERROR1 – fill timeout

ERROR2 – temperature probe error

ERROR4 – no change in temperature when expected

## Maintenance (continued)

### ▲ WARNING: SHOCK AND BURN HAZARD

To prevent electric shock and burn hazard, all tasks described in this section are to be performed by a trained and qualified service technician.

### ▲ WARNING: SHOCK HAZARD

Disconnect power before attempting any electrical repairs.

## Component Tests

### Water Inlet Valve Test

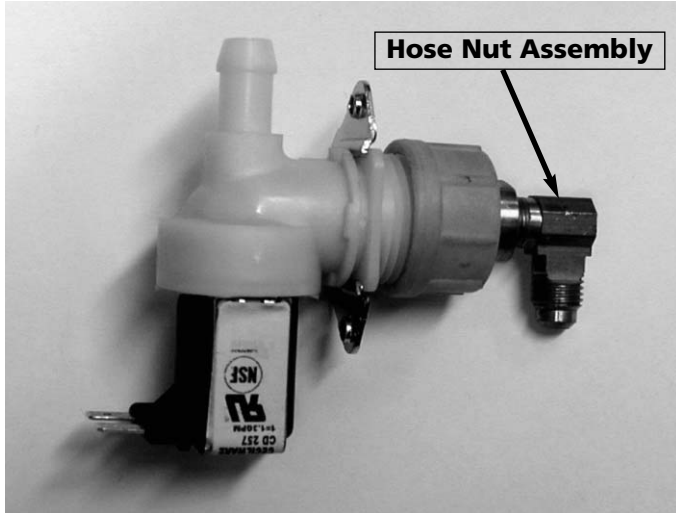

1. Turn power OFF. If the water level rises inside a partially filled tank, the Water Inlet Valve is leaking.
2. Disconnect wires from the Water Inlet Valve coil and connect a 2 wire line cord to the terminals. Plug it into a 115V outlet. If water flows in and stops when you pull it out, the Valve is working fine. Repeat this test a few times. The problem may be in the Probe or Water Level Control Board.
3. If the water does not flow in when the cord is plugged into an electrical outlet, the Solenoid coil may be damaged, opened or the valve may have an obstruction preventing the water from flowing in.
4. Clean or replace it.

### Dual Probe Test

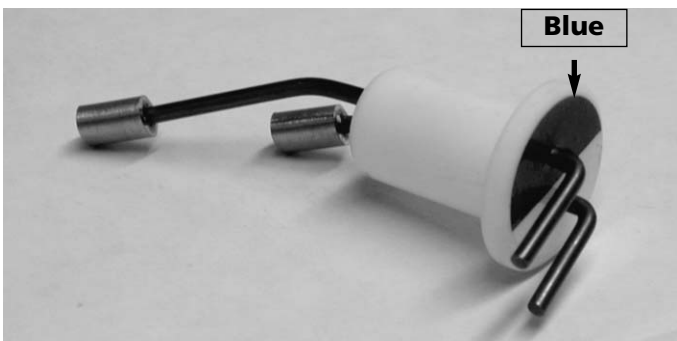

If lack of water persists, check the probe as follows:

1. Turn on the power and water supply. Check inside the tank to make sure the water is below the Probe. Pull the BLUE wire and terminal OFF the Probe rod.
2. If water still does not flow after the wire is disconnected from the Probe, the problem may be in the Solid State Dual Level Control Board.
3. If water starts flowing into the tank, the Probe may be grounded, due to excessive liming. Check with Ohm meter.
4. Clean or replace probe.

### Dual Probe Liquid Level Controller Test

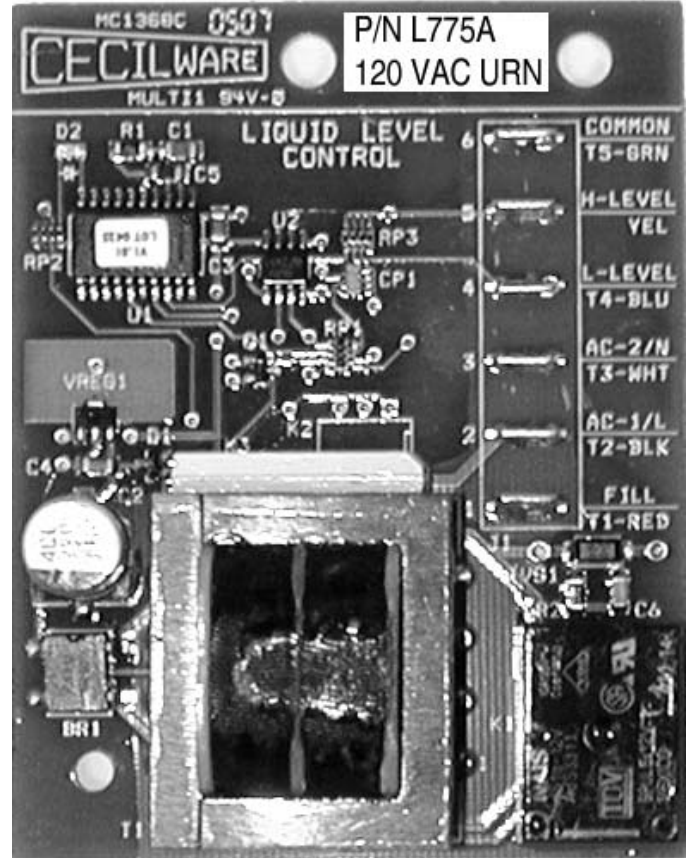

Check the Controller as follows:

1. Make sure there is power input to the Controller at the terminals AC1 & AC2. Your voltmeter should read 115 Volts. It should read the same at terminals AC1 & FILL when the water level is low. This is the output power to actuate the coil of the Solenoid Valve to open it.
2. The lack of voltage at terminals AC1 & L-LEVEL or H-LEVEL indicates that the Controller is not working properly.
3. Make sure all wire connections are tight, including ground.
4. If after this, the Controller is still failing to open the Water Inlet Valve, replace it.

# Parts Diagram

(refer to key on page 15)

## AUTOMATIC COFFEE URNS

### FE SERIES

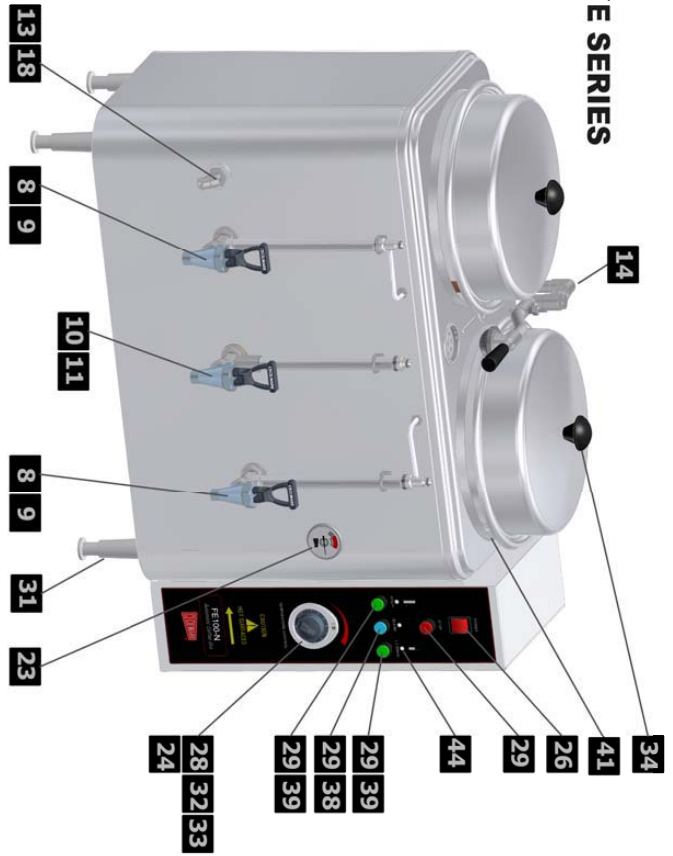

### CL & CH SERIES

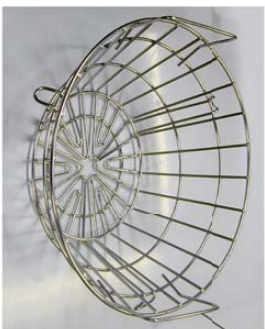
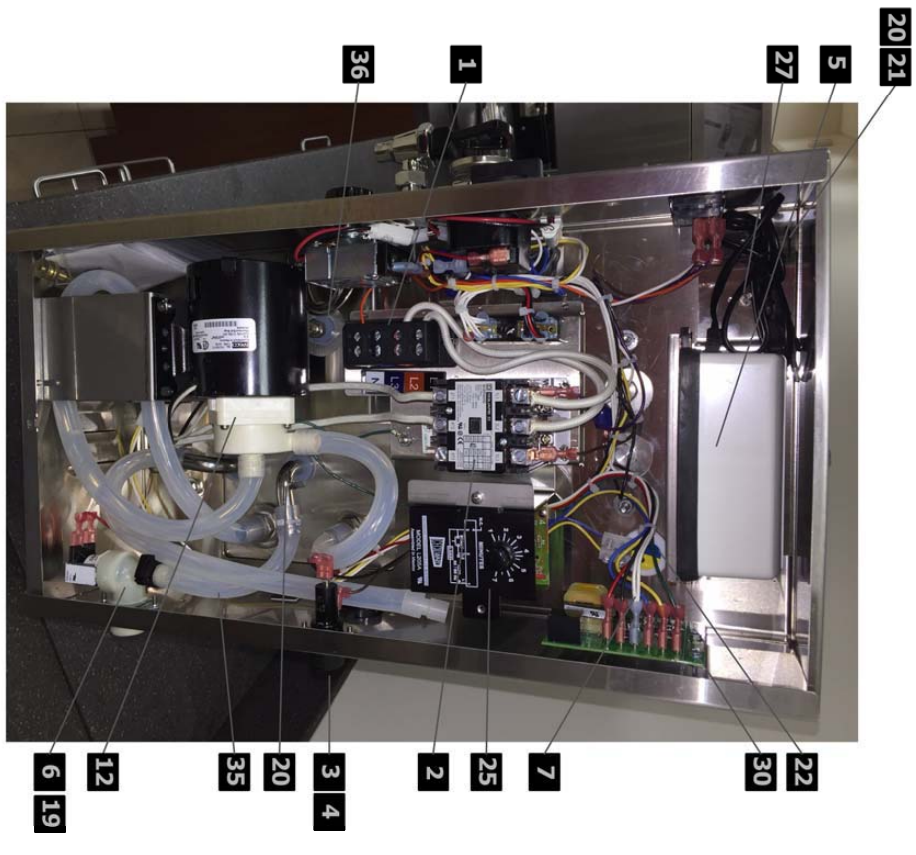

43



15 16 17

# Parts Diagram (continued)

(refer to key on page 15)

## AUTOMATIC COFFEE URNS

### SPRAY ARM ASSEMBLY

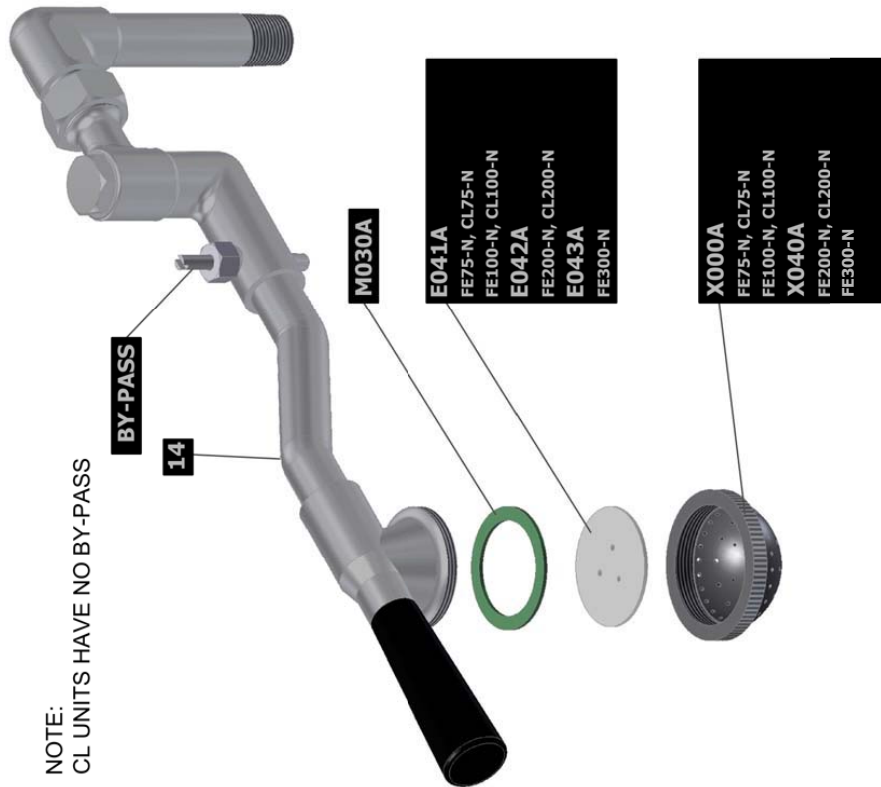

NOTE:  
CL UNITS HAVE NO BY-PASS

### FAUCET, COFFEE

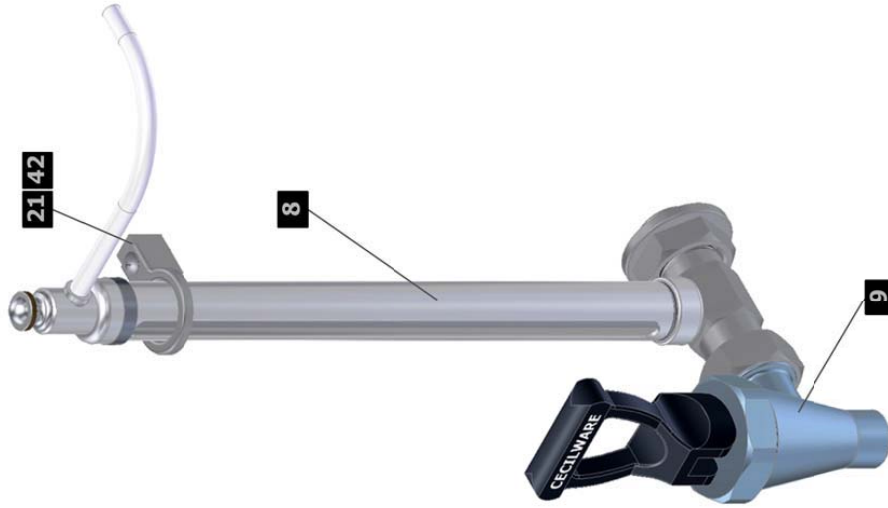

### FAUCET, HOT WATER



To prevent lime buildup, especially in hard water areas, remove and clean spray head cap and spray head disc frequently. To clean swivel valve, loosen nut and remove spray arm assembly from urn.  
Remove sediment by inserting a pipe cleaner through small hole in valve.  
If maximum setting of timer fails to deliver enough water, check water pump.

## Parts Diagram (continued)



## Parts List

ITEM #	PART #	DESCRIPTION	QUANTITY								
			FE75N	FE75N DUAL BREW	CL75N	FE100N	FE100N DUAL BREW	CL100N	FE200 DUAL BREW	CL200	FE300
1	B157A	TERMINAL BLOCK 4 WIRE	1	1	1	1	1	1	1	1	1
2	C036AL	CONTACTOR, 3 POLE, 50 AMP - (240V)	-	-	-	-	-	-	-	-	-
	CG12AL	CONTACTOR, 3 POLE, 50 AMP - (120V)	1	1	1	1	1	1	1	1	1
3	C395AL	FUSE 6A SC-6	1	1	1	1	1	1	1	1	1
4	C396AL	FUSEHOLDER, SC-6	1	1	1	1	1	1	1	1	1
5	A508004	AIR PUMP, AGITATOR (120V ONLY)	1	1	1	1	1	1	1	1	1
	C512A	AIR PUMP, AGITATOR (220V)	-	-	-	-	-	-	-	-	-
6	L080Q	WATER INLET VALVE (120V ONLY), .75 GPM	-	-	-	-	-	-	-	-	1
	L080X	WATER INLET VALVE (240V), .75 GPM	-	-	-	-	-	-	-	-	1
	CD417	WATER INLET VALVE (120V ONLY), .35 GPM	1	1	1	1	1	1	-	-	-
	CD418	WATER INLET VALVE (240V), .35 GPM	1	1	1	1	1	1	-	-	-
	280-00020	WATER INLET VALVE .50 GPM (120V ONLY)	-	-	-	-	-	-	1	1	-
	280-00020+C223AL	WATER INLET VALVE .50 GPM+ 240V COIL	-	-	-	-	-	-	1	1	-
7	CH243	WIRING HARNESS	-	-	-	-	-	-	1	-	1
	CH244	WIRING HARNESS	-	-	-	-	-	-	-	1	-
	CH387	WIRING HARNESS (MECH. TIMER)	-	-	1	-	-	1	-	-	-
	343-00128	WIRING HARNESS (120V ONLY)	1	1	-	1	1	-	-	-	-
	343-00129	WIRING HARNESS (240V)	1	1	-	1	1	-	-	-	-
8	355-00032	SIGHT GLASS ASSEMBLY (COFFEE)	1	1	1	2	2	2	-	-	-
	355-00034	SIGHT GLASS ASSEMBLY (COFFEE)	-	-	-	-	-	-	3	3	-
	355-00036	SIGHT GLASS ASSEMBLY (COFFEE)	-	-	-	-	-	-	-	-	2
9	D017Q	FAUCET, SHANK ASSEMBLY (COFFEE)	1	1	1	2	2	2	2	2	2
	220-00132	SIGHT GLASS GAUGE BASE	1	1	1	2	2	2	2	2	2
10	D022Q	FAUCET, SHANK, VALVE ASSEMBLY (WATER)	1	1	1	1	1	1	1	1	1
11	355-00035	SIGHT GLASS ASSEMBLY (WATER)	1	1	1	1	1	1	-	-	-
	355-00037	SIGHT GLASS ASSEMBLY (WATER)	-	-	-	-	-	-	-	-	1

\* Replace coil on inlet valve with 220V coil

# Parts List (continued)

ITEM #	PART #	DESCRIPTION	QUANTITY									
			FE75N	FE75N DUAL BREW	CL75N	FE100N	FE100N DUAL BREW	CL100N	FE200 DUAL BREW	CL200	FE300	
12	E000A	WATER PUMP (120V ONLY) (Prior to 3/2014)	1	1	1	1	1	1	1	1	1	1
	E070A	WATER PUMP (240V) (Prior to 3/2014)	1	1	1	1	1	1	1	1	1	1
	A533-033	WATER PUMP (120V ONLY) (After 3/2014)	1	1	1	1	1	1	1	1	1	1
	A533-034	WATER PUMP (240V) (After 3/2014)	1	1	1	1	1	1	1	1	1	1
13	359-00074	OVERFLOW FITTING W/ NUT	1	1	1	1	1	1	1	1	1	1
14	235-00007	COMPLETE SPRAY ARM ASSY NO BYPASS	-	-	-	-	-	-	-	-	-	-
	235-00008	COMPLETE SPRAY ARM ASSY W/ BYPASS	-	-	1	-	-	1	-	-	-	1
	235-00009	COMPLETE SPRAY ARM ASSY W/ BYPASS	1	1	-	1	1	-	-	-	-	-
	235-00010	COMPLETE SPRAY ARM ASSY W/ BYPASS	-	-	-	-	-	-	1	1	-	-
15	320-00015	HEATER ELEMENT 5KW 240V 1PH	CONTACT TECHNICAL SERVICE DEPARTMENT WITH SERIAL NUMBER TO DETERMINE CORRECT PART #									
	320-00016	HEATER ELEMENT 8KW 240V 1PH										
	320-00017	HEATER ELEMENT, 240V 5KW 3PH										
	320-00018	HEATER ELEMENT, 240V 6KW 3PH										
	320-00019	HEATER ELEMENT, 240V 8KW 3PH										
	320-00020	HEATER ELEMENT 7KW 240V 1PH										
	320-00021	HEATER ELEMENT, 480V 5KW 3PH										
	320-00022	HEATER ELEMENT, 480V 8KW 3PH										
	320-00031	HEATER, 240V/5700W SIDE MOUNT										
	320-00035	HEATER, 240V/4000W SIDE MOUNT										
	320-00037	HEATER, 480V/4000W SIDE MOUNT										
	G026T	HEATER, 240V 8KW3PH WYE CONFIG										
18	H023J	TUBE, OVERFLOW	-	-	-	-	-	-	1	1	-	-
	H059J	TUBE, OVERFLOW	-	-	-	-	-	-	-	-	-	1
	H429Q	TUBE, OVERFLOW	1	1	1	1	1	1	-	-	-	-
19	7327	HOSE CLAMP	1	1	1	1	1	1	1	1	1	1
20	H416Q	WATER INLET TUBE	1	1	1	1	1	1	1	1	1	1
21	K808A	RETAINER MOUNTING BLOCK	2	2	2	3	3	3	3	3	3	3
22	344-00038	LEVEL SENSOR, DUAL PROBE	1	1	1	1	1	1	1	1	1	1
23	L007A	THERMOMETER, BREW DIAL	1	1	1	1	1	1	1	1	1	1
24	L154A	TIMER, MECHANICAL (0 - 15 MINUTES)	-	-	1	-	-	1	-	1	-	-
25	L205A	TIMER, SINGLE (120V)	1	-	-	1	-	-	-	-	-	1
	L210A	TIMER, SINGLE (240V)	1	-	-	1	-	-	-	-	-	1
	L214A	TIMER, DUAL (120V)	-	1	-	-	1	-	1	-	-	-
	L216A	TIMER, DUAL (240V)	-	1	-	-	1	-	1	-	-	-
26	L155AL	ROCKER SWITCH, POWER ON-OFF	1	1	1	1	1	1	-	-	-	-
	L019A	SWITCH, POWER ON-OFF	-	-	-	-	-	-	1	1	1	1
27	L238A	DELAY TIMER-SOLID STATE (120V)	1	1	1	1	1	1	1	1	1	1
	L210A	DELAY TIMER-SOLID STATE (240V)	-	-	-	-	-	-	-	-	-	-
28	L029A	THERMOSTAT 25A, URNS	-	-	-	-	-	-	1	1	1	1
29	L584A	SWITCH, PUSHBUTTON	3	4	-	3	4	-	4	-	-	3
30	L775A	DUAL LEVEL CONTROL HI-LO (120V)	1	1	1	1	1	1	1	1	1	1
	L776A	DUAL LEVEL CONTROL HI-LO (220V ONLY)	1	1	1	1	1	1	1	1	1	1
	349-00047	CONTROL BOARD TANK (W/ DIGITAL DISPLAY)	1	1	1	1	1	1				
31	355-00054	LEGS (4" ADJ) (4 PER BAG)	1	1	1	1	1	1	1	1	1	1
32	355-00070	KNOB THERMOSTAT	1	1	1	1	1	1	1	1	1	1
33	M016A	THERMOSTAT BEZEL	1	1	1	1	1	1	1	1	1	1
34	M027A	KNOB, URN COVER	1	1	1	2	2	2	2	2	2	2
35	M326AL	WATER INLET HOSE 3/8 x 5/8 x 8"	1	1	1	1	1	1	1	1	1	1
36	M461AL	SILICONE GROMMET 12mm	3	3	3	3	3	3	3	3	3	3
37	M462AL	SILICONE GROMMET 15mm	-	-	-	-	-	-	-	-	-	-
38	M876AL	BLUE BUTTON (BLEND)	1	1	1	1	1	1	1	1	1	1
39	M877AL	GREEN BUTTON (BREW)	2	2	-	2	2	-	2	-	-	2
40	MA15A	COPPER GASKET, TEFLON FILLED	6	6	6	7	7	7	7	7	7	7
41	Q027Q	LINER ASSY & COVER (FE75/ FE100)	1	1	1	2	2	2	-	-	-	-
	Q094Q	LINER (FE300)	-	-	-	-	-	-	-	-	-	2
	Q204Q	LINER ASSY & COVER (FE200)	-	-	-	-	-	-	2	2	-	-
42	UB17A	SIGHT GLASS RETAINER	2	2	2	3	3	3	3	3	3	3
43	V002A	BREW BASKET, FE75 / FE100	1	1	1	1	1	1	-	-	-	-
	V003A	BREW BASKET, FE200	-	-	-	-	-	-	1	1	-	-
	V081A	BREW BASKET, FE300	-	-	-	-	-	-	-	-	-	1
44	32004L	INDICATOR LIGHT W/ RED LENS	2	3	-	2	3	-	3	-	-	2
45	ABB3WP	FILTER PAPER (FE75N/FE100N)	1	1	1	2	2	2	-	-	-	-
	ABB6WP	FILTER PAPER (FE200N)	-	-	-	-	-	-	2	2	-	-
	ABB810WP	FILTER PAPER (FE300N)	-	-	-	-	-	-	-	-	-	2

# Wiring Diagram

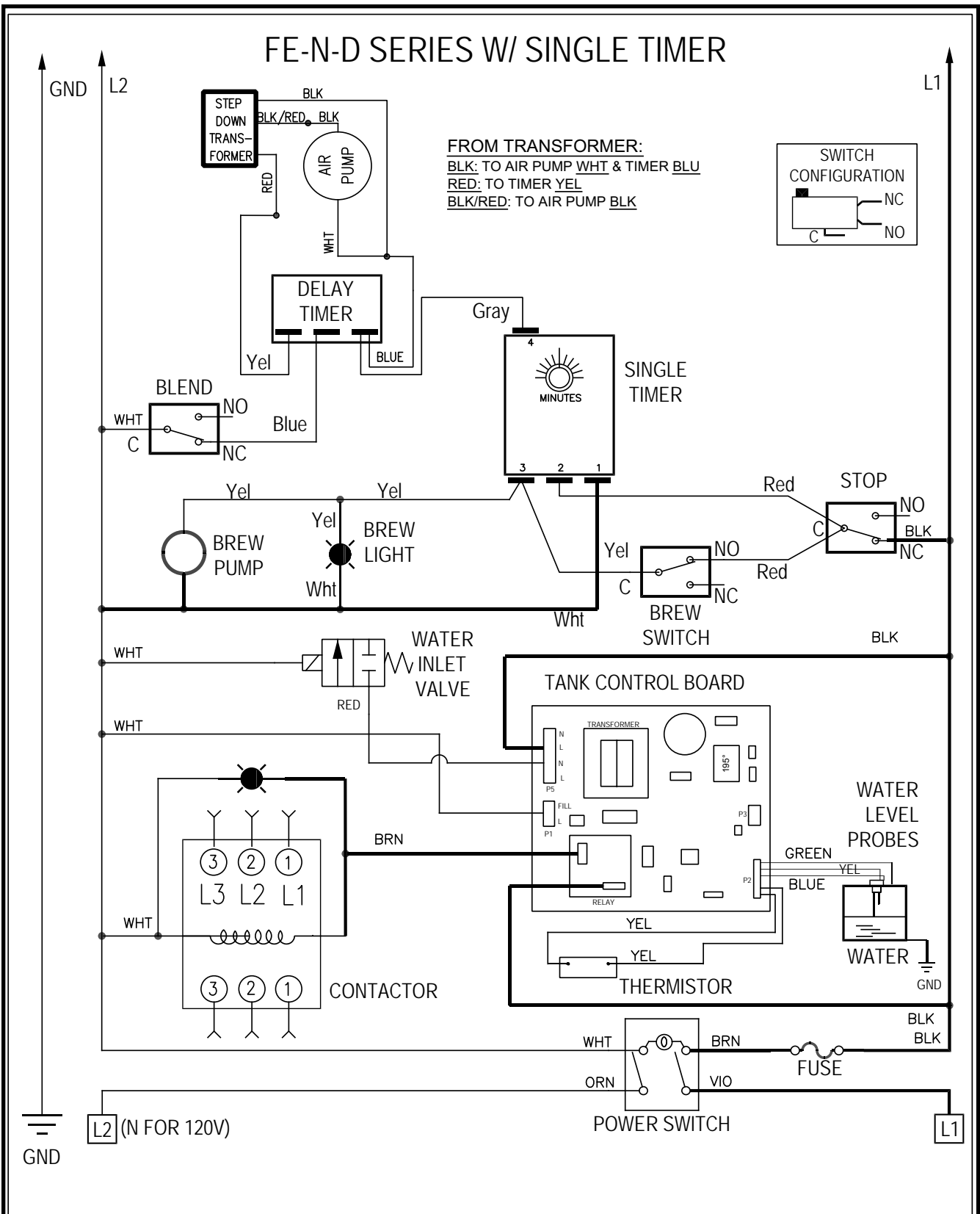

FE-N-D SERIES WIRING DIAGRAM P/N 390-00036

REV A

# Wiring Diagram (continued)

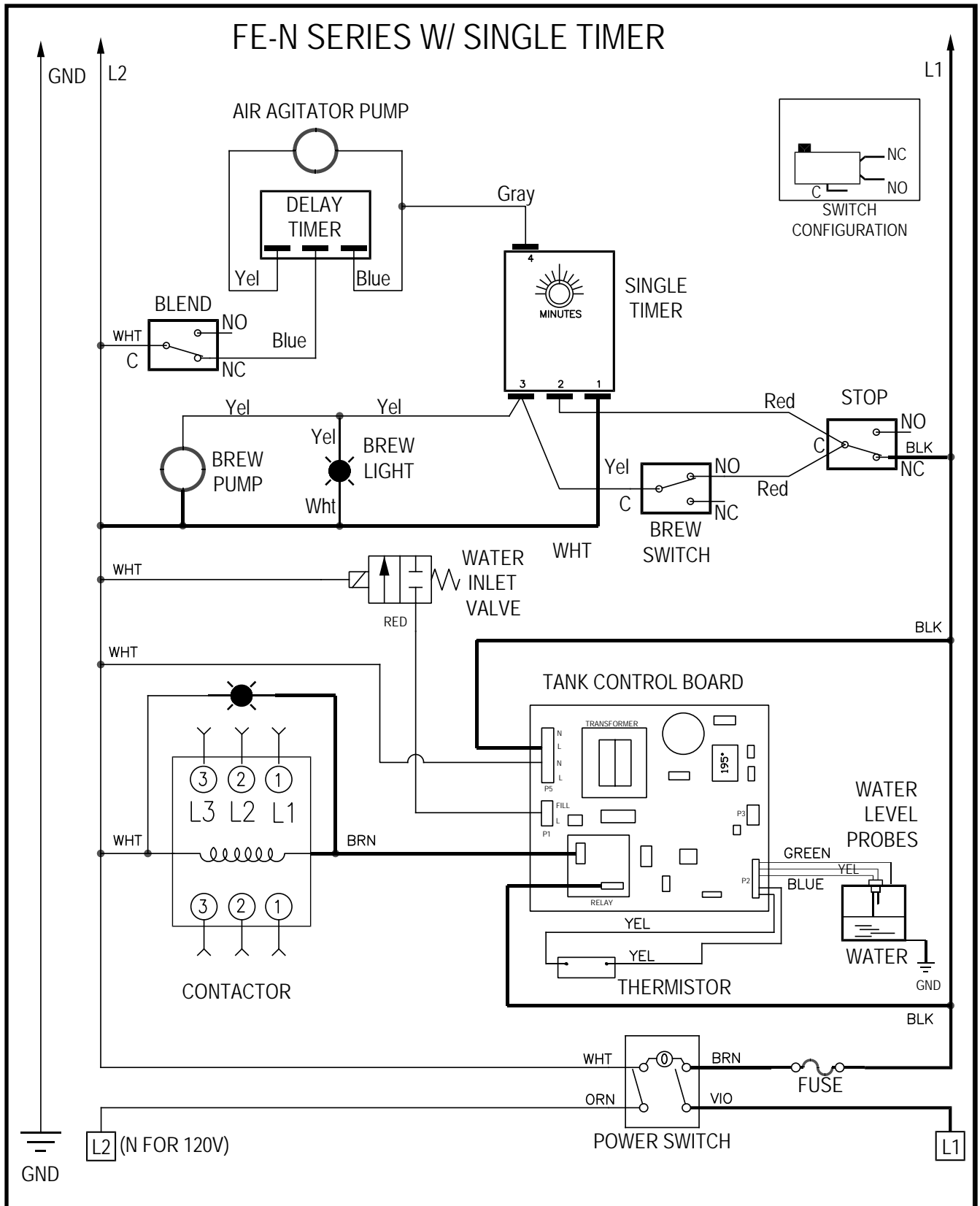

NE249  
SH 1 OF 3

# Wiring Diagram (continued)

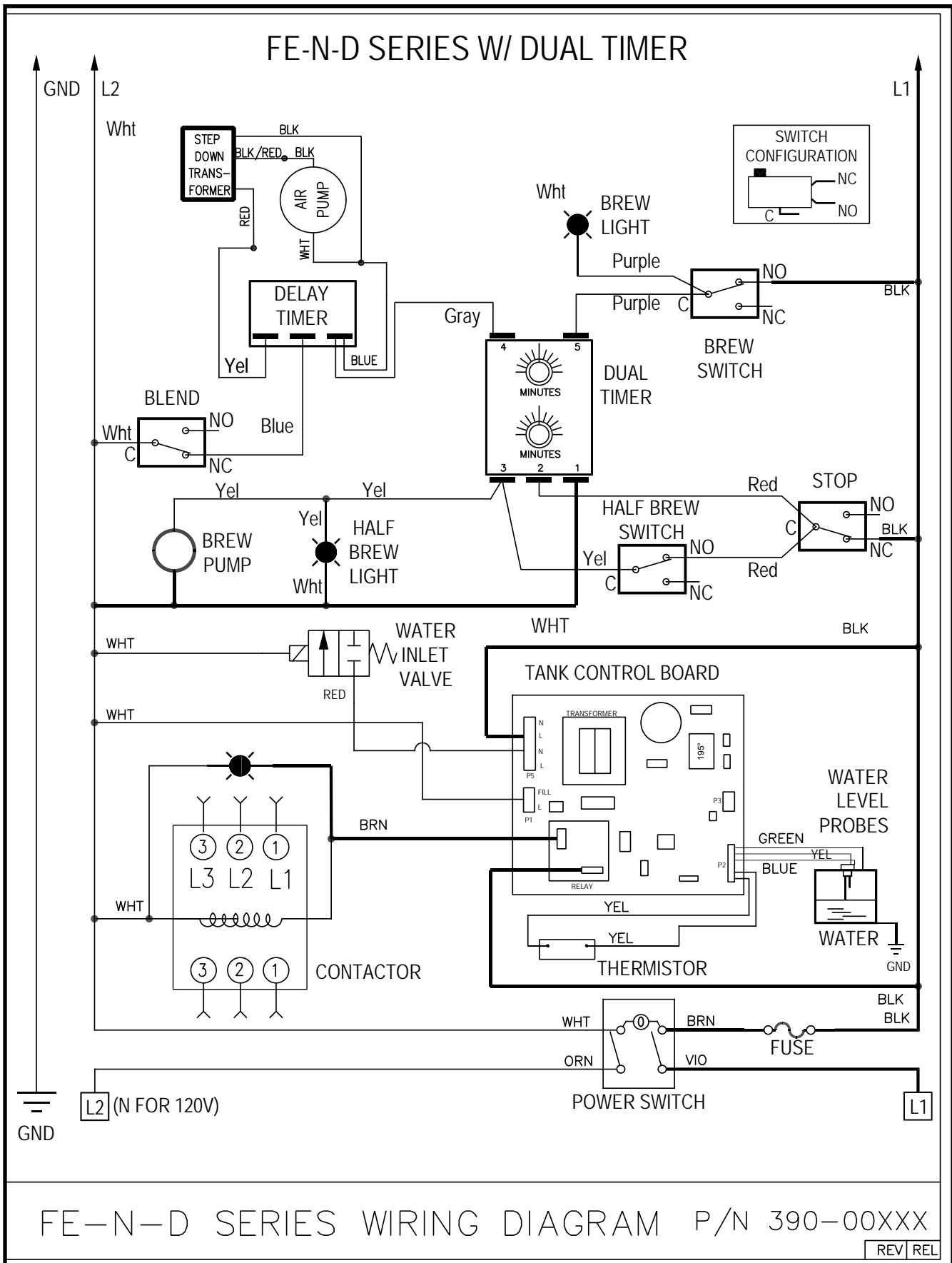

FE-N-D SERIES WIRING DIAGRAM P/N 390-00XXX

REV REL

# Wiring Diagram (continued)

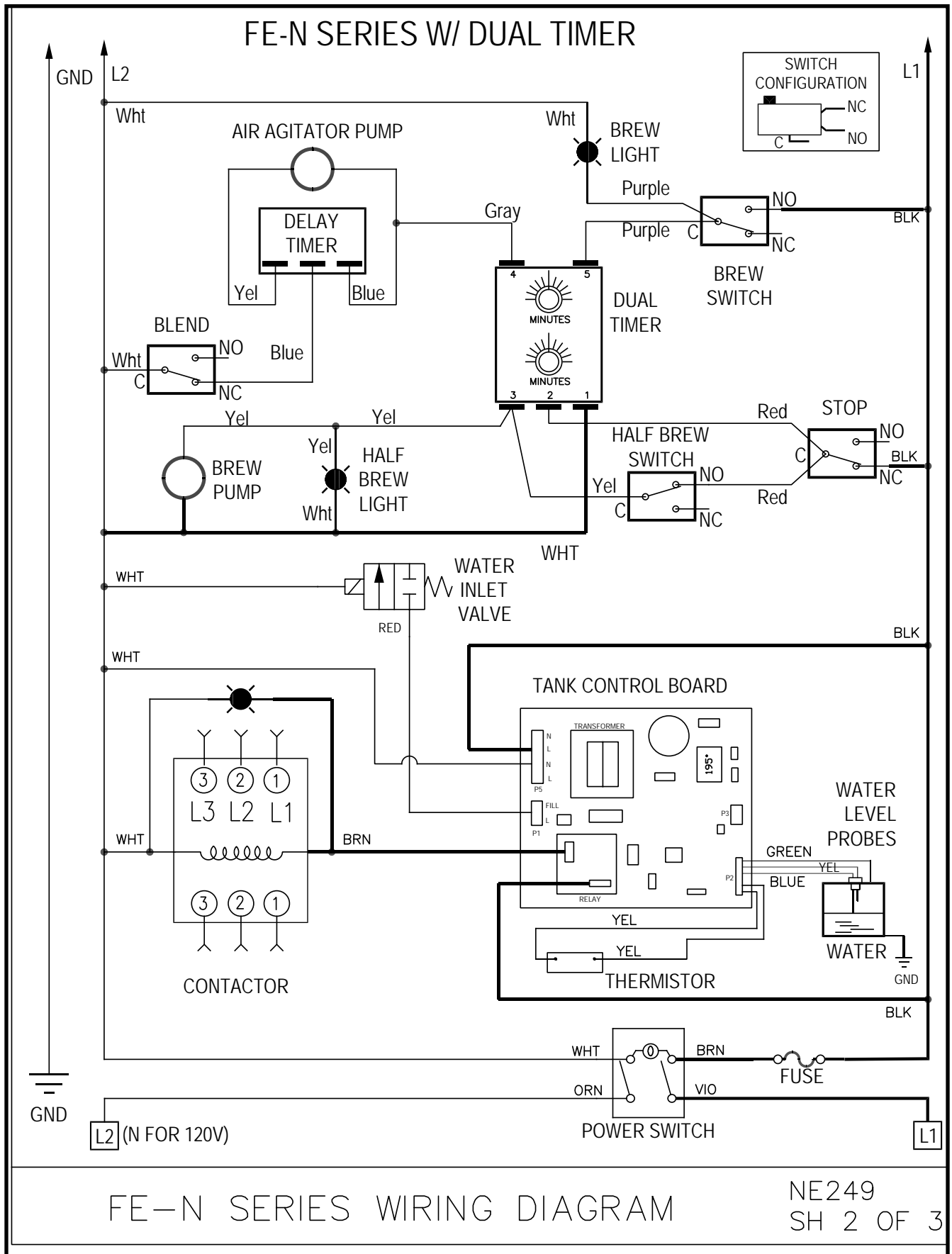



# Wiring Diagram (continued)

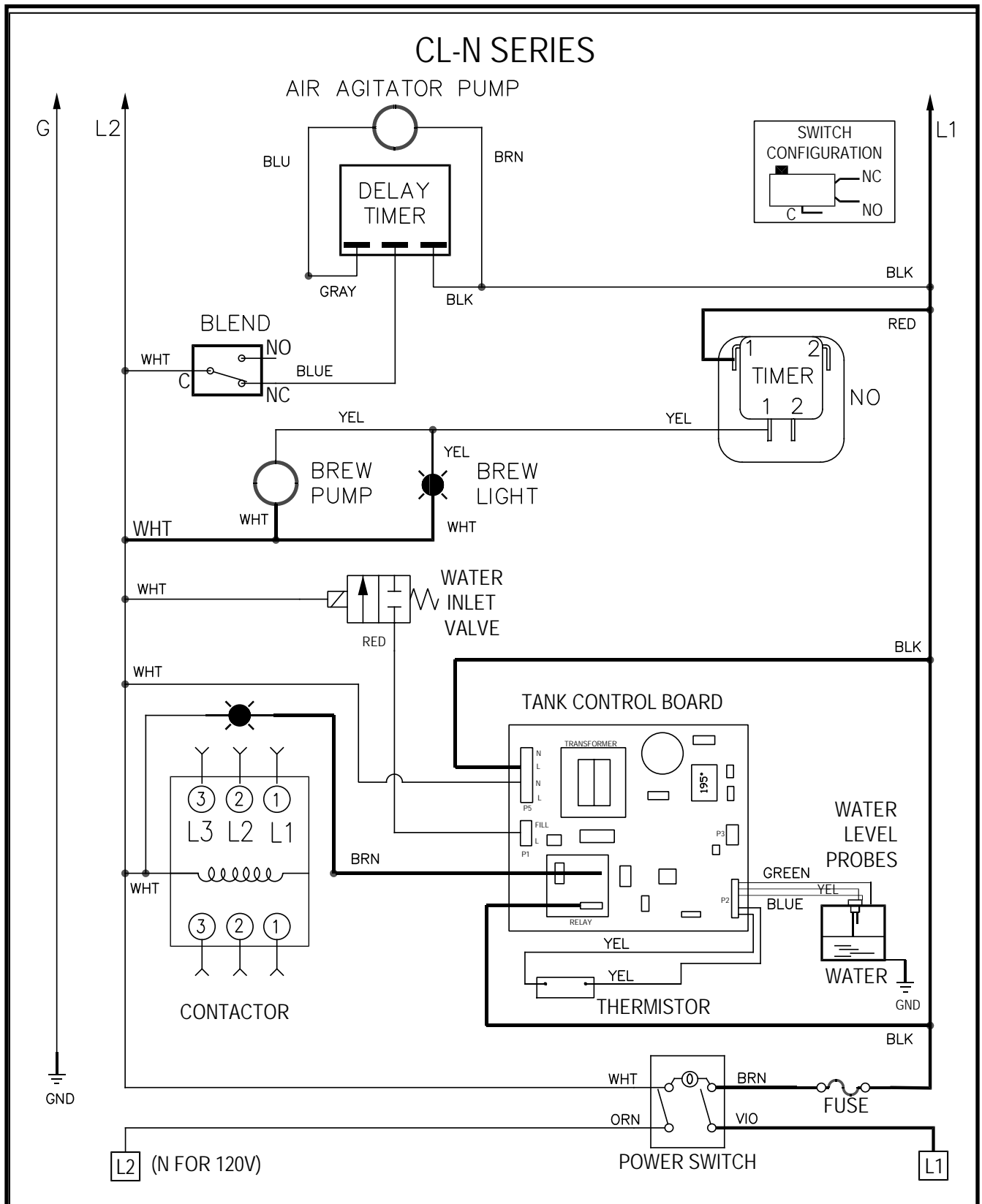

CL-N SERIES WIRING DIAGRAM

P/N 390-00XX1

REV. A

# Wiring Diagram (continued)

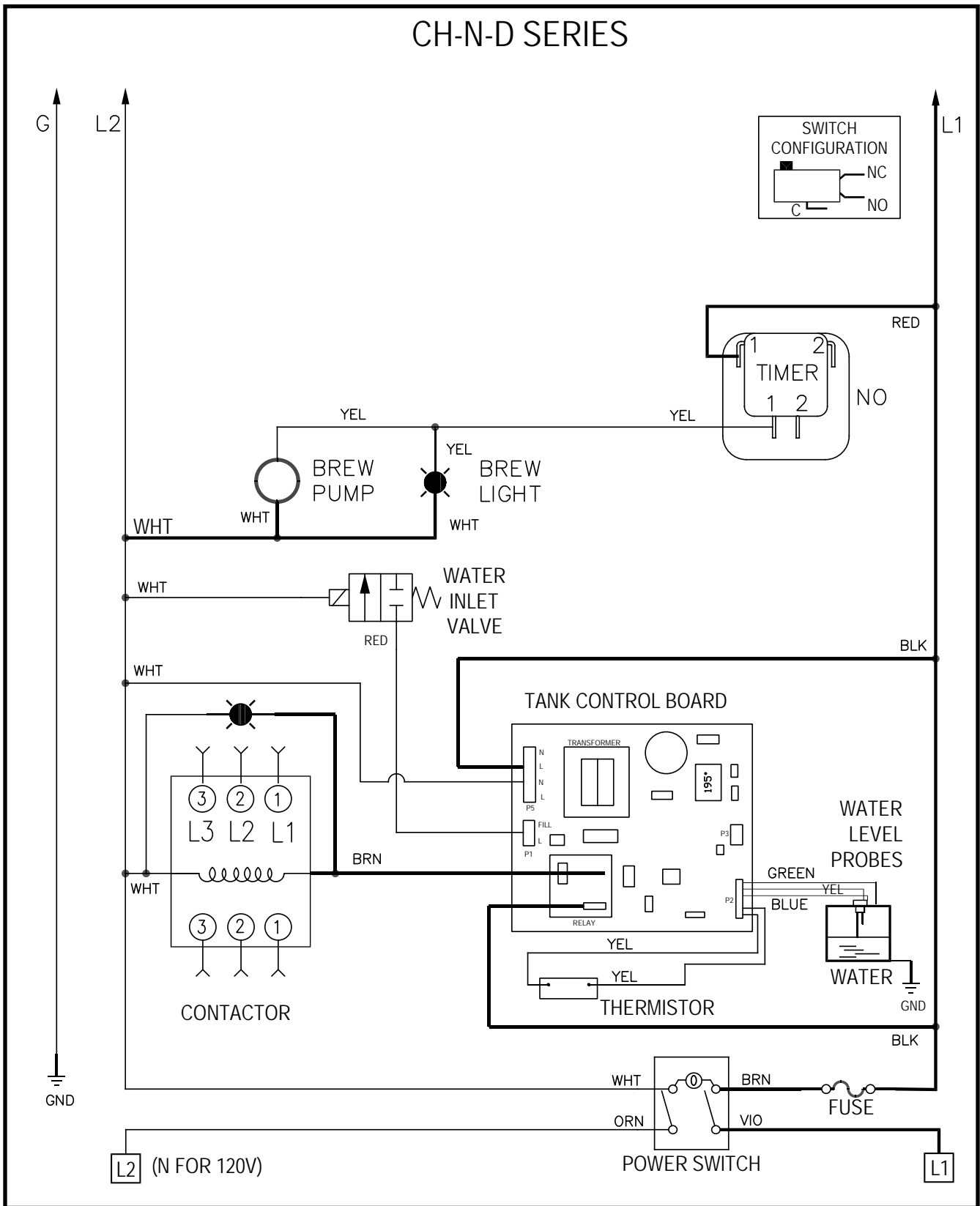

CH-N-D SERIES WIRING DIAGRAM

P/N 390-00XXX

REV. REL

# Wiring Diagram (continued)

NE313

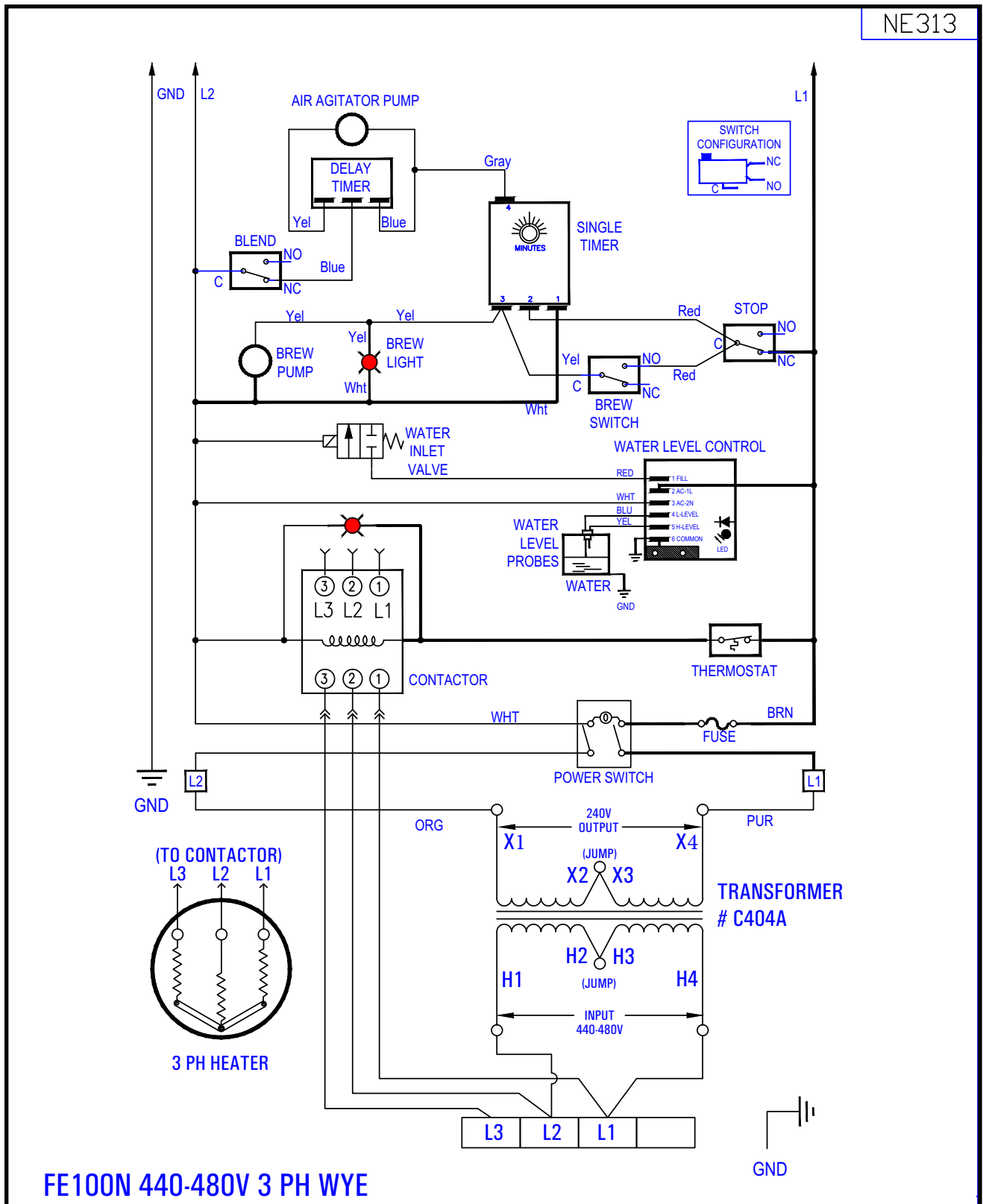

# Wiring Diagram (continued)

## FOR ALL AUTOMATIC COFFEE URNS

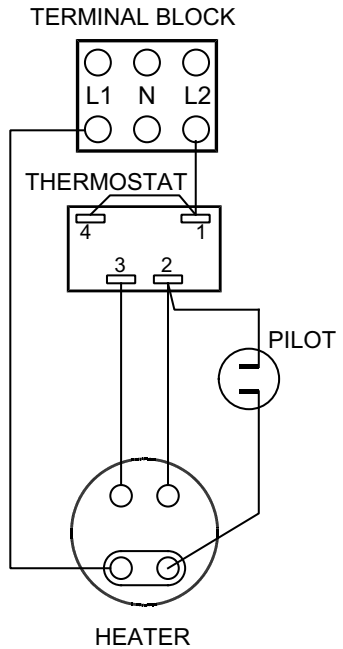

FE75 - 7KW 1PH  
FE100 - 8KW 1PH

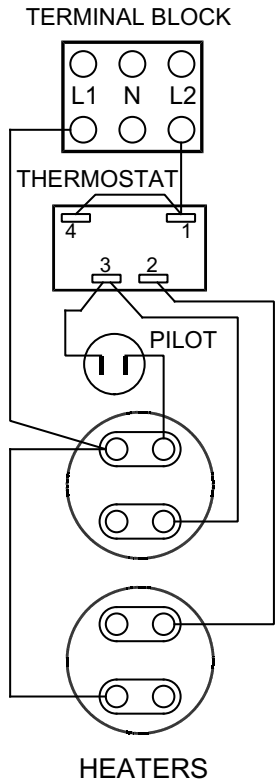

FE200 - 10KW 1PH

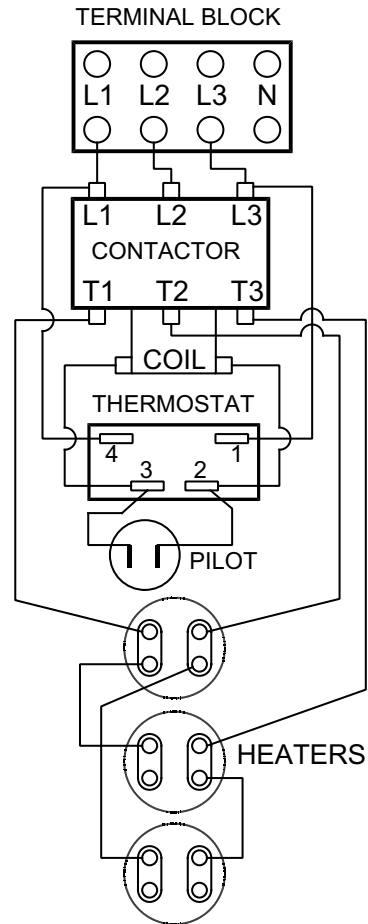

FE300 - 15KW 3PH

# Wiring Diagram (continued)

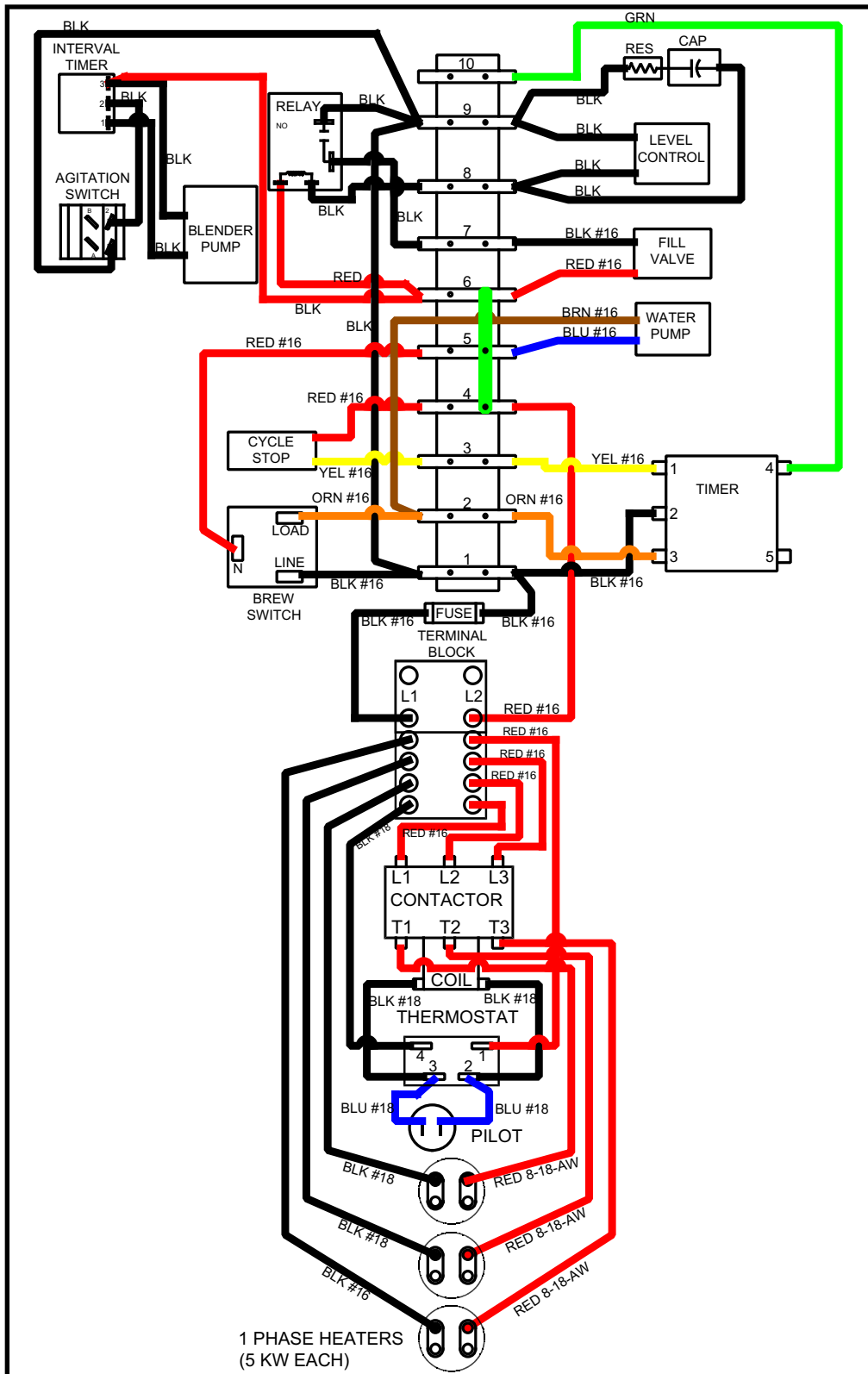

# Wiring Diagram (continued)

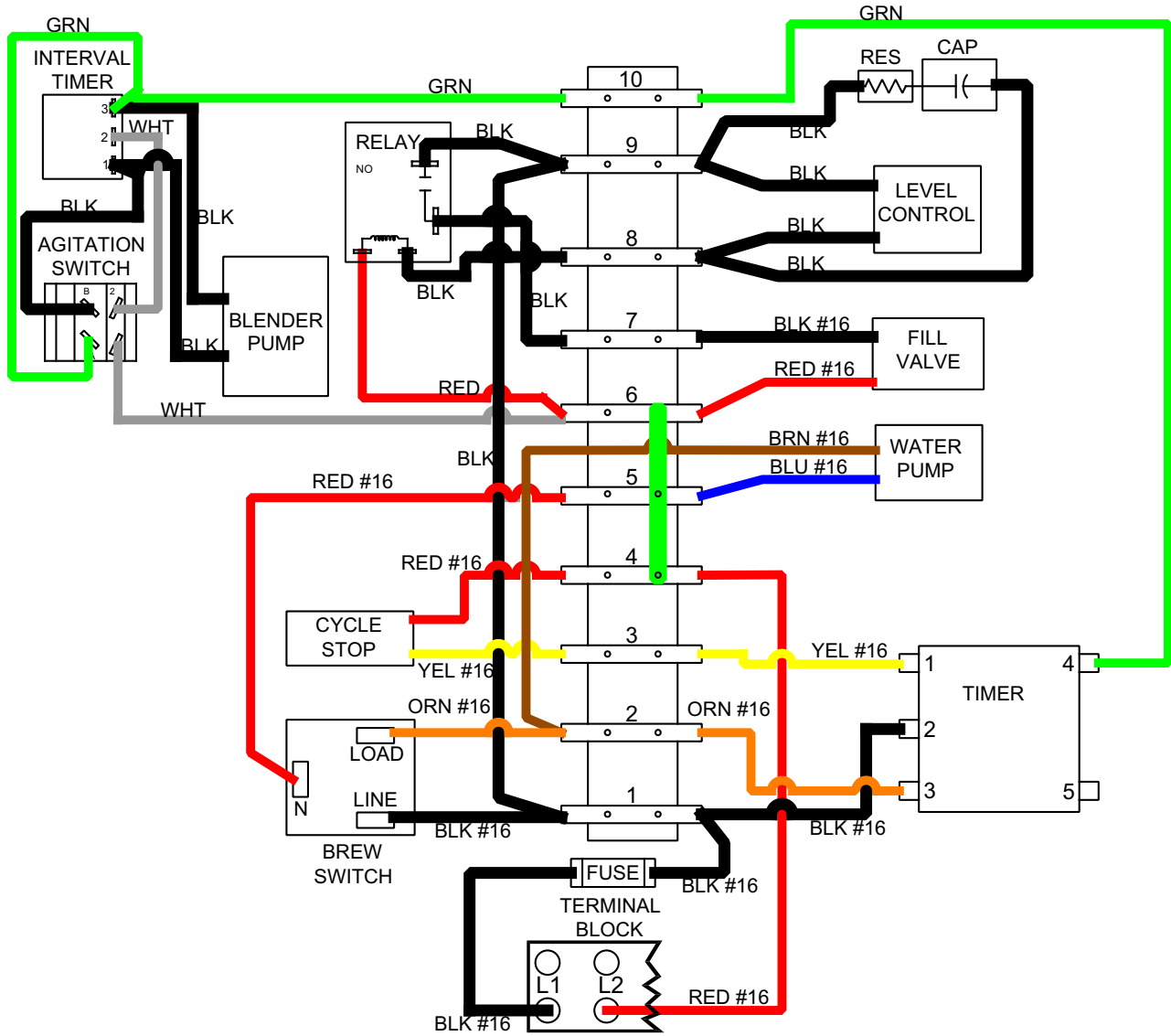

# Wiring Diagram (continued)

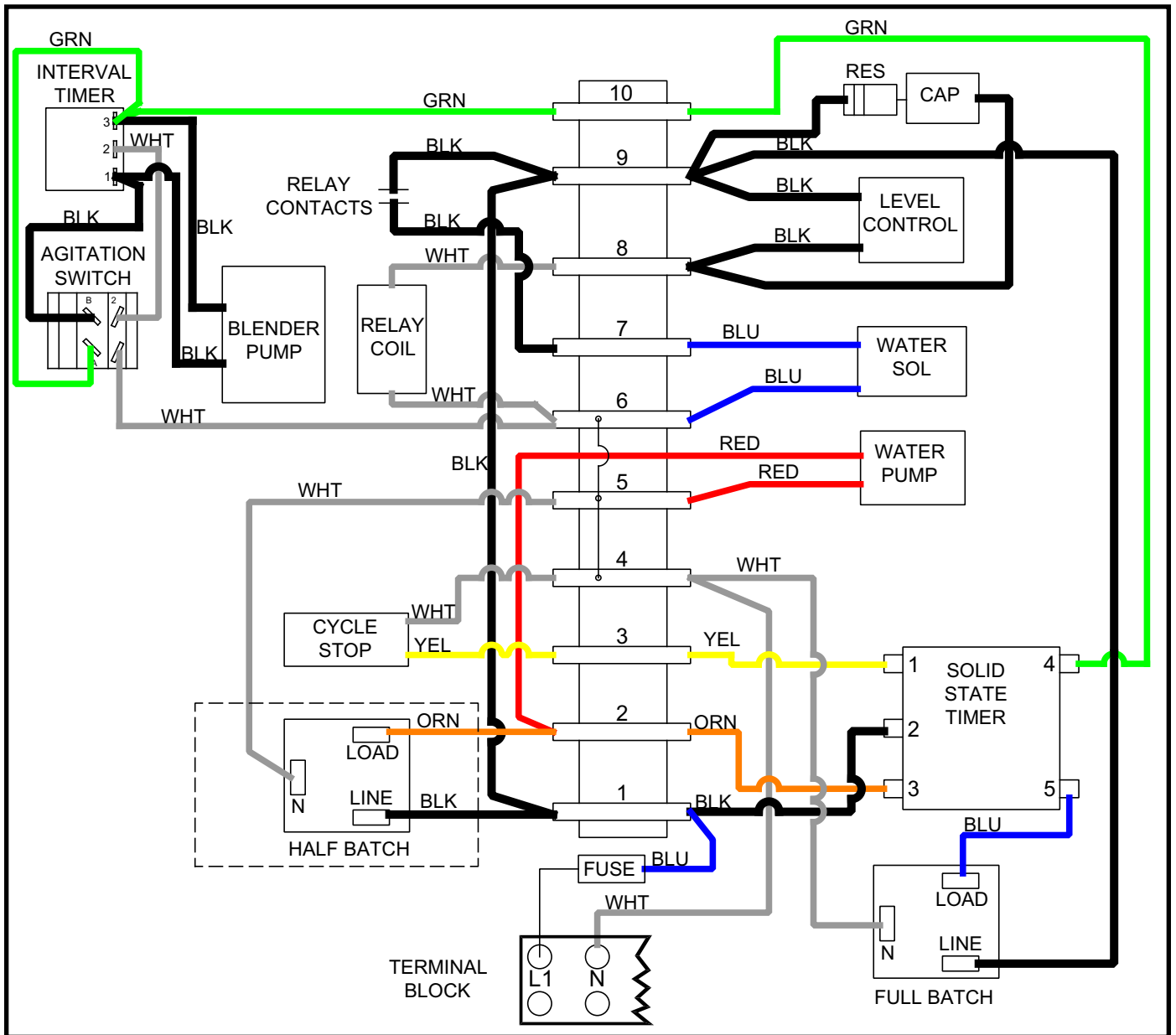





**Grindmaster-Cecilware**

4003 Collins Lane, Louisville, KY 40245 USA  
Phone: 502.425.4776 Toll Free: 800.695.4500  
Fax: 502.425.4664  
Web: gmcw.com Email: info@gmcw.com

©2018 Grindmaster-Cecilware  
Printed in USA



**Grindmaster  
Cecilware**

0518 Form # CW-326-02  
Part # 390-00070