

# Shuttle Brewer & Airpot/Shuttle Brewers

## Operation and Instruction Manual

For Models P300E, P400E, P400ESHP, RAP300E,  
RAP400E, RAPS300E, RAPS400E

### Table of Contents

Installation and Start-up .....	1-2
Warning Labels .....	3
Operation .....	4
Adjustments .....	5-8
Care and Cleaning .....	9-10
Service .....	10-11
Troubleshooting	
Filling Problems .....	12
Heating Problems .....	13
Brewing Problems .....	14
Parts Illustrations	
Models P300E & P400E .....	15
Model P400ESHP .....	16
Model RAP400E .....	17
Model RAPS400E .....	18
VSB-400.....	19
Shuttle CS-LL .....	20
Rough-In Drawings	
Model P300.....	21
Model P400 & P400ESHP .....	22
Model RAP300 .....	23
Model RAP400 .....	24
Model RAPS300 .....	25
Model RAPS400 .....	26
VSB-300 .....	27
VSB-400 .....	28
Wiring Diagrams	
P300E/P400E with 1 Batch Timer .....	29
P300E/P400E with 2 Batch Timer.....	30
RAP300E/RAP400E.....	31
RAPS300E/RAPS400E.....	32
P400ESHP .....	33
Drawing #091-548 .....	34
Drawing #091-182 .....	35

### Installation:



### WARNING

#### ELECTRIC SHOCK HAZARD!

Installation of this appliance should be performed by qualified service personnel only. Improper installation could result in electrocution.

See rough-in drawings in this manual for dimensions and locations of electric and water input.

#### Set-Up/Position

- 1) Remove the brewer from the packing material and attach its legs.
- 2) Position the brewer on a strong, stable table or counter. Check the level front to back and side to side. Adjust the legs to the correct level.

#### IMPORTANT:

THE PERSON INSTALLING THIS APPLIANCE IS RESPONSIBLE FOR ENSURING THAT ELECTRIC AND WATER CONNECTIONS MEET THE REQUIREMENTS OF THE NATIONAL ELECTRIC CODE, NATIONAL PLUMBING CODE, AND ANY LOCAL ORDINANCES.

The electric and water hook-up locations are behind the front panel. Remove the four screws fastening this panel for access to these connections.

### Water Hook-up

- 1) The water line may enter through holes on the rear or the bottom of the brewer. Use the right hand opening for water.
- 2) Use 3/8" copper or flexible water line to prevent strain. Do not use low temperature plastic tubing. The connection to the fill valve is 3/8" flare.
- 3) Water line pressure must be from 30 to 70 psi.
- 4) Hot (up to 160°F) or cold water may be used. Hot water offers faster recovery between brews.
- 5) Install a shut-off valve near the brewer.
- 6) Installing a filtering system can improve the taste of brewed coffee and extend the life of the brewer. If your water has high calcium (lime), chlorine, or iron content, this is especially important. The filter should be the lime inhibiting type if cold water is used. Contact your local water treatment professional regarding the type of filter you should use based on water quality and volume of water used.

*Prior authorization must be obtained from Grindmaster Corporation for all warranty claims.*



**GRINDMASTER™**  
CORPORATION

### Grindmaster Corporation

4003 Collins Lane

Louisville, KY 40245 USA

(502) 425-4776

(800) 695-4500 (USA & Canada only)

(800) 568-5715 (Technical Service Only)

FAX (502) 425-4664

[www.grindmaster.com](http://www.grindmaster.com)

## Installation (con't)

### Electric Hook-up

- 1) The electric ratings for your brewer are printed on its nameplate. Typical electric ratings are:

P300, P400, RAP300, RAP400

Optional 120/208V, 3.8kW, 18A or 120/240V 5.0kW, 21A, 1 phase

Standard 120/208V, 5.0kW, 24A or 120/240V 6.6kW, 28A, 1 phase

RAPS300, RAPS400

Standard 120/208V, 4.4KW, 21A or 120/240V, 5.6KW 24A, 1 phase

P400ESHP

Standard 440V, 12.5KW, 16.3A, 3 phase WYE

If the brewer includes the three heater tank option C21A, the ratings will be different. Always see the nameplate for correct ratings.

- 2) The brewer should be connected to its own circuit with a fused disconnect switch or a circuit breaker near the brewer.
- 3) Attach the appropriately sized cord to the brewer with a cord grip for the 1 1/2" electric input opening. The cord may enter through the rear or bottom on the left side of the brewer. Use an oil resistant cord such as type SO, SOO, SAO, STOO, SEO, SJO, SJOO, SJTO, SJTOO, SJEO, HSO, HSOO, HSJO, or HSJOO. Alternatively, flexible conduit and type THHN wires may be used. Use only copper conductors.
- 4) Standard connection is 1 phase 3 wire. Connect the two lines to L1 and L2 on the terminal block. If the brewer is wired for three phase, a lug, L3, is provided on the terminal block. A neutral line must be connected to the N terminal.



**Never use the ground conductor as a neutral. This could cause electrocution.**

- 5) The body of the brewer must be grounded. A ground lug is provided for this purpose.

### Start-up

- 1) Turn on the water supply to the brewer. Check for leaks.
- 2) Turn on the electric supply. The brewer will begin to fill.
- 3) Replace the front access panel.
- 4) Once the brewer is full, it will take 15 to 35 minutes to heat. The water hot light will turn on when up to temperature.
- 5) Insert the brew baskets and place a shuttle or airpot under the baskets. Brew at least one batch from each side. Check the level in the container to be sure the brew volume is correct. Remember that when using coffee, the level will be lower. Do this for both batch sizes when provided. The water must be hot to check the levels. If adjustments are needed, see the adjustments section of this manual.

## Warning Labels

The following warning labels were on your dispenser when it was shipped from the factory. They should remain on your dispenser in good, readable condition at all times. If one of your labels is missing or damaged, order a replacement label immediately.

### Part # A546-445

Located on front splash panel and lid of machine.

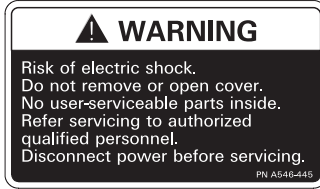

### Part # A546-020 (P-300), A546-129 (P-400)

Located near warmer plates.



### Part # A546-020 (P-300), A546-129 (P-400)

Located near water faucet.



### Part # A546-213

Located on front splash panel.



### Part # A71949

Located on brew baskets.



## Operation

### CAUTION

#### **HOT LIQUID HAZARD!**

**Water used for brewing coffee is very hot. Use caution when brewing, pouring, or transporting coffee. Accidental spills may result in severe burns.**

- 1) RAPS Brewers require the accessory warmer base placed over the pegs on the brew shelf before brewing into a shuttle. Plug the base into the receptacle on the side of the brewer. The receptacle is only energized when a shuttle is in place.
- 2) Place an empty, warm shuttle or airpot on the shelf, counter, or accessory base (depending on model) under the brew head. Turn on the warmer if a shuttle is used.
- 3) If the shuttle is not warm, allow the warmer to heat the shuttle. Only a short brew of water will speed this. A cold shuttle will significantly lower the temperature of the brewed coffee.
- 4) Remove the filter basket and line with a filter paper. Paper size is 13 x 5 for the smaller basket, BB1.5, and 14 x 5 for the larger, BB2.0.
- 5) Place ground coffee in the filter basket. Your coffee supplier can help you select the right amount of coffee and grind. Coffee brewing experts recommend between 6.5 and 8 ounces of coffee per gallon of water for most applications. A full shuttle is 1.4 gallons and a full airpot is 0.80 gallon.
- 6) Slide the basket into the brewer making sure the spout lines up with the top of the shuttle or airpot.
- 7) Check that the correct batch size is selected. Check the WATER HOT light. If lit, press start.
- 8) Brew time is about 4 minutes for a full shuttle, less for airpots and half batches. After the brew, allow the coffee to drip for 1 to 2 minutes.

### CAUTION

**Coffee basket contains very hot water until the drip is completed. Early removal of a dripping basket could result in burns.**

- 9) Dump the grounds from the basket and rinse for the next brew. Coffee is ready to serve.
- 10) The shuttle may be placed on remote warming stations. Use caution when moving a full shuttle.

# Adjustments

## WARNING

### Electrical Shock Hazard!

Dangerous electric voltages are present near adjustable components. All adjustments should be performed by qualified service personnel only.

All adjustable components are located under the top cover. To access these parts:

- 1) Shut off the electric line to the brewer or unplug the brewer.
- 2) Remove the single screw fastening the top cover. Remove the top cover.
- 3) Pull forward and lift off the top cover.

### Brew Volume, Brew Timer

The brew volume of the brewer is controlled by its timer. The batch size is directly proportional to the timer setting. The timer adjustment is located under the top cover. On twin brewers, there is one timer for each brew head.

Depending on the model, American Metal Ware offers three types of timer adjustments. Look at the instructions for the type of timer you have. There will always be a small variation ( $\pm 5\%$ ) in level from batch to batch.

**Note: Always adjust bypass before adjusting timer because bypass affects brew rate.**

Before making the timer adjustment, do the following:

- 1) Brew a batch of water to determine where the level falls. Using a stop watch, determine the current brew volume.
- 2) To determine the desired time setting, use the following formula:

$$\text{desired brew time} = \frac{\text{desired brew volume}}{\text{current brew volume}} \times \text{current brew time}$$

### Adjusting the Timer

**Standard single batch timer:** RAP and P models without half batch include this timer, (see Figure 1). This timer is adjustable from 1 to 8 minutes. After removing the cover, do the following:

- 1) Use the timer label to make an approximate adjustment of the timer.
- 2) After adjusting the timer, brew a batch of water to check the volume. Repeat adjustment, tweaking the timer knob until the volume is correct.

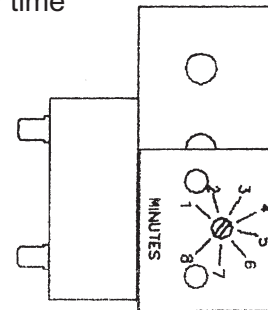

Figure 1  
Single Batch Timer

**Two Batch Timer with Knob Adjustment, See Figure 2:**

This timer is adjustable from 15 seconds to 5 minutes. Locate the adjustment knobs under the top cover.

Set this timer by adjusting the knob. The batch selector switch picks the adjustment potentiometer which the timer will see.

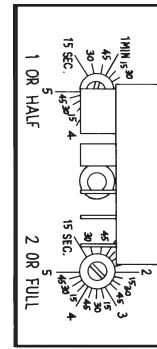

Figure 2  
Two Batch Timer

**Two Batch Timer with Counter Adjustment, See Figure 3:**

The two batch size timer may also be used with optional counter potentiometer to ease adjustments. Each batch size is adjustable from 00 to 99. The timer settings for this timer are tabulated on the table below. This chart is for making an approximate setting. You may need to click up or down to make fine adjustments to volume. Each number is about 3 seconds.

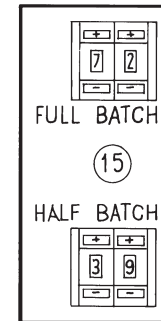

Figure 3  
Two Batch Timer  
w/Counter Adjustment

Counter Settings for NCC Q4F-0300-341AM Timers

Counter Setting	Time (min:sec)	Counter Setting	Time (min:sec)	Counter Setting	Time (min:sec)
00	0:15	35	2:03	65	3:26
10	0:46	40	2:17	70	3:39
15	1:01	45	2:31	75	3:53
20	1:17	50	2:45	80	4:06
25	1:32	55	2:59	85	4:20
30	1:47	60	3:13	99	5:00

**Bypass Adjustment**

The bypass valve adjusts the amount of water which bypasses coffee grounds and dilutes the final brew (see Figure 4). The factory setting is no bypass.

Bitter coffee results when the amount of ground coffee is too small. Therefore, if your coffee is brewing too strong, it is better to adjust the bypass valve instead of reducing the amount of coffee.

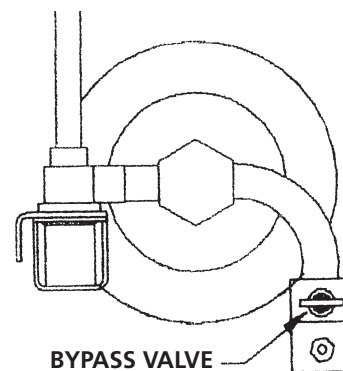

Figure 4  
Bypass Valve

### To Adjust the Bypass:

- 1) Shut off and open brewer as described at the beginning of the adjustments section.
- 2) Locate the bypass valve for the brew head you wish to adjust. Valve is on the right and front of the BREW valve.
- 3) Open the valve (counter clockwise) to the desired setting. Use the table below as a guide:

BYPASS SETTING	BYPASS: % OF TOTAL BREW
closed	0
1 turn	8
2 turns	12
3 turns	22
4 turns	33

- 4) Measure the bypass setting:
  - a) Remove the brew basket.
  - b) Place an empty shuttle without its lid under the spray head.
  - c) Place a measuring cup under the bypass nozzle.
  - d) Press START and brew water for about thirty seconds or until measuring cup is almost full. Press STOP.
  - e) Record the amount of water in the bypass measuring cup.
  - f) Add this to the water in the shuttle and record, measure the total amount of water.
  - g) The bypass percent is calculated as:

$$\text{Bypass \%} = (\text{Bypass Volume} / \text{Total Volume}) \times 100$$

- 5) Tweak the valve adjustment until the bypass is set as desired.

**Note: The bypass is accurate to  $\pm 4\%$ .**

### Thermostat Adjustment

The main thermostat adjusts the water temperature in the tank. Factory setting is 200°F. This is the ideal temperature for brewing most coffee. Water should never boil in the tank. If water is boiling, adjust the thermostat. There are two types of thermostats available. Mechanical is standard and solid state is optional. See the adjustment instructions for the thermostat in your brewer.

#### **Standard Mechanical Thermostat:**

- 1) Shut off power and open cover.
- 2) Locate thermostat mounted on tank. See Figure 5.
- 3) Turn the shaft counter clockwise to decrease temperature, opposite to increase temperature.

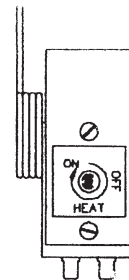

Figure 5  
Mechanical Thermostat

- 4) If the maximum temperature adjustment needs to be increased, insert a small flat screwdriver into the shaft. Turn the calibration screw counter clockwise to increase the maximum temperature.

**Optional Solid State Thermostat:** This control maintains temperature within 3°F. The adjustable range is from 155°F to 205°F.

See Figure 6.

- 1) Shut off power and open top cover.
- 2) Locate thermostat on bracket mounted to front panel.
- 3) Adjust the knob to the temperature desired. This control cannot be set above 205°F.

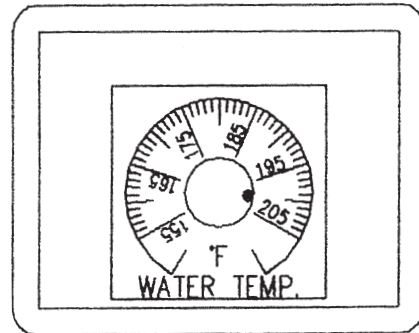

Figure 6  
Solid State Thermostat

**Optional Brew Thermostat Adjustment:** Your brewer may include the optional low temp/no brew thermostat, (see Figure 7). This will not allow a brew unless the water is up to temperature. The factory setting is 192°F. If you wish to adjust this, do the following:

- 1) Shut off power and remove top cover.
- 2) Locate the thermostat mounted on the water tank.
- 3) To increase the set point, turn the shaft clockwise. We do not recommend adjusting this above 192°F which may cause excessive delays between batches.
- 4) For accurate setting of the thermostat, remove the bulb from the brewer and immerse in water known to be 190°F. Adjust the knob so the thermostat closes at this point.

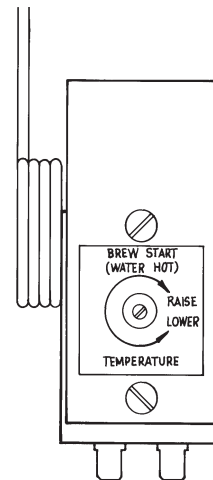

Figure 7  
Brew Thermostat

## Cleaning



### **Burn Hazard!**

**Hot liquids and surfaces are present in this equipment. To avoid burns use caution when cleaning. Rinse hot parts with cold water before cleaning. Use gloves or a heavy cloth when removing hot parts from brewer.**

### **After Each Brew:**

- 1) Dispose of grounds and rinse brew basket.
- 2) Rinse shuttle or airpot containers before reuse.

### **Every Day:**

- 1) Wash brew basket with warm soapy water. The wire basket is removable to aid cleaning.
- 2) Remove spray head(s), located above brew basket(s), using gloves or a heavy towel. Wash off coffee oils and clean any plugged holes.
- 3) Clean shuttles with warm soapy water and a brush or towel.
- 4) Clean airpots with warm soapy water and bottle brush. Be careful, glass interior breaks easily. Use only a soft cloth and warm soapy water or stainless steel polish on the outside to avoid scratches.
- 5) Wipe exterior of brewer with a damp cloth. Do not use abrasives which will scratch surface.
- 6) If shuttles are to be left on warmer all night, fill with water to avoid coffee oil burn-in.

## Weekly or Bi-Weekly, Depending on Use

- 1) Fill shuttles with one gallon, 2/3 full, of hot water.
- 2) Pour into the shuttle liners the recommended concentration of urn cleaner (excessive amounts of cleaner will attack the stainless steel).

*Urn cleaners that have been used successfully:*

DIP-IT, manufactured by Economics Laboratories, Inc.  
4 Corporate Park Drive  
White Plains, NY 10604

OXYLITE, manufactured by Avril, Inc., Syndet Division  
601 N. Third Street  
Reading, PA 19601

- 3) Scrub the liner interior with a plastic bristle brush.
- 4) Remove the knurled nut at the top of the gauge glass and clean the glass with a small bottle brush.
- 5) Pour out the contents of the shuttle.
- 6) Remove the handle assembly of the shuttle faucet by unscrewing the plastic bonnet.
- 7) Gently wash the faucet seat cup with a soft cloth and warm soapy water.
- 8) Wash the faucet shank with a bottle brush.
- 9) Soak airpot pick-up tube assembly in hot soapy water. Urn cleaner may be used for stronger cleaning.
- 10) Clean the warmer and bottom of shuttle surfaces. These surfaces must be clean for proper heat transfer.
- 11) Polish the exterior of the brewer with stainless steel cleaner. Use the appropriate cleaner for brass, copper, or vinyl if these optional finishes are provided.

## Service

The rest of this manual contains information to aid the service person who is working on this equipment. This page has information on performing *common service tasks*. Following this is the *Troubleshooting* section which can help diagnose problems which are divided into three basic systems: filling, heating, and brewing.

Next is an *illustrated parts breakdown* which will help in the selection of repair parts. If further assistance is needed, call our Technical Service Department at **(502) 425-2776** or **800-695-4500** (USA & Canada only) Monday -Friday between 8:00 am and 8:00 pm EST.

*Wiring diagrams* are also provided. Locate the basic diagram for the model you are working with. If there are any options, see Diagram #091-548 (page 31 of this manual) which shows the wiring alterations for Shuttle Brewer & Airpot/Shuttle Brewer options.

## Service (con't)

### Drain Water Tank

Always empty the tank before shipping.



**Draining of tank should be performed by a qualified service technician. The tank contains very hot water. May cause severe burns.**

**Note:** Brewer may contain over 5 gallons of hot water.

- 1) Prepare a heat resistant container to drain tank water into.
- 2) Shut off power to the brewer.
- 3) Remove the front access panel.
- 4) Pinch or clamp the silicone hose connected to fill valve.
- 5) Disconnect hose from outlet barb on fill valve.
- 6) Place hose over drain and release clamp.
- 7) Allow the tank to drain completely.

**NOTE:** It may be necessary to pinch the hose and stop the water before container is full. Carefully reinstall hose over fill valve outlet, then empty container. Repeat steps 4-7 completely to drain tank.

### Remove Brew Valve

- 1) Disconnect electric power to machine.
- 2) Remove top cover and remove wires and small tube from valve.
- 3) Tilt inlet of valve down and pull sideways out of spray tee.
- 4) Clamp rubber tubing and disconnect valve from tubing.

### Remove Heater

- 1) Disconnect power and remove top cover of brewer.
- 2) Disconnect wire leads to heater.
- 3) Remove tank cover by loosening retaining screw. Cover is lifted up with heater attached. Heater is then removed.
- 4) Replace heater with sealing washers in same configuration. When tightening nuts, hold element so it does not twist.
- 5) Replace tank cover ensuring O-ring seal is good.
- 6) Replace heater wires. Be sure all electrical connections are secure.

## Troubleshooting: Filling, Heating, and Brewing

<b>Filling Problems</b> <i>The filling system consists of the following components:</i> <ul style="list-style-type: none"> <li>• Liquid Level Control, located behind the brewer front panel.</li> <li>• Liquid Level Probes, located on the tank top, secured by wing nut, under the top cover.</li> <li>• Fill Valve, located behind the front panel.</li> </ul>			
Problem	Possible Cause	Service Check	Remedy
<b>Overfilling water tank even when power is off.</b>	Fill valve not sealing properly.	Water entering tank continuously, usually slowly.	Disassemble valve and clean out dirt. Valve may need new plunger if seal is worn.
	Fill valve installed backwards.	Look for direction of arrow on valve body.	If arrow on valve is pointing toward water inlet, remove valve and install correctly.
<b>Overfilling water tank only when power is on.</b>	High electrode coated with lime or faulty.	Jumper HI terminal on level control to metal enclosure stops fill.	Remove electrode assembly and clean both probes. If this does not work, replace assembly.
	Missing or faulty connection of C terminal on level control to metal enclosure.	Jumper from C terminal to metal body stops fill.	Make secure connection of C to metal body.
	Fill valve connected to heat terminal on level control.	Check connections.	Connect black lead for valve to FILL on level control.
	Liquid level control is faulty.	Jumper from HI to C or metal enclosure does not stop fill.	Replace level control.
<b>Tank does not refill.</b>	No power at equipment.	Nothing operates.	Check main switch or circuit breaker, brewer's circuit breaker or power switch if provided.
	No water at equipment.	Cracked water inlet fitting.	Make sure all water supply line valves are open.
	Water strainer clogged.	Water pressure before strainer but not after.	Remove and clean or replace strainer's mesh.
	No power to level control.	Check for 120V AC across H and N terminals on level control.	If no voltage, check for loose or broken wires.
	Level control faulty.	Disconnect probe wire to HI terminal on level control. Check for 120V at FILL terminal.	If no 120V at FILL terminal, replace level control.
	Electrodes faulty.	Tank fills only when probe wire is disconnected from HI terminal on level control.	Replace electrodes. If no remedy, check for improper wiring or level probe tip touching metal.
	Fill valve faulty.	120V is across FILL and N on level control, but no fill.	Disassemble valve and clean or replace plunger if frozen. If plunger is OK, coil may need replacement.

## Troubleshooting: Filling, Heating, and Brewing

### Heating Problems

*The heating system consists of the following components:*

- Liquid Level Control, located behind the front enclosure panel.
- Liquid Level Probes, located on the tank top, secured by wing nut, under the top cover.
- Thermostat, located on the tank or on the front of top control panel under top cover.
- Heater Relay, located in top control section under top cover.
- Heating Elements, located on tank top under top cover.

Problem	Possible Cause	Service Check	Remedy
<b>Tank does not heat.</b>	Low electrode faulty or covered w/lime.	Jumper from XL terminal on level control to metal body allows heating.	Clean electrodes, check wiring. If no remedy, replace electrodes.
	Level control faulty.	Check for 120V between H and N terminals on level control. If OK, jumper between XL and metal body and check for 120V between HEAT and N terminals.	If 120V is not at HEAT, replace level control.
	Thermostat faulty or out of calibration.	Make sure thermostat is turned on. Jumper across thermostat allows heating.	Recalibrate thermostat. If no remedy or thermostat does not cycle, replace thermostat.
	Heater relay coil faulty. (electric heat)	Check for 120V across contactor coil.	If correct voltage, but contactor not closing, replace contactor.
	Heater contactor contacts faulty.	Check for heater voltage between each heater pole on contactor, and different pole.	If no continuity across contactor when it is closed, replace contactor.
	Heater faulty.	Check resistance across elements with wires disconnected.	If resistance is much different than 10 to 15 ohms, replace heater.
<b>Recovery time is very long.</b>	Heater faulty.	See above.	See above.
	Low temp/no brew thermostat set too high.	Water is above 190 degrees F, but HOT WATER light is off.	Turn down brew thermostat, see adjustments.

***If you still need help, call our Technical Service Department at (502) 425-4776 or (800) 695-4500 (USA & Canada only) Monday thru Friday 8 am - 8 pm EST or an authorized service center in your area. Please have the model and serial numbers ready so that accurate information can be given. Prior authorization must be obtained from Grindmaster Corporation's Technical Service Department for all warranty claims.***

## Troubleshooting: Filling, Heating, and Brewing

<b>Brewing Problems</b>			
<p><i>The brewing system consists of the following components:</i></p> <ul style="list-style-type: none"> <li>• Start and Stop, switches located in the top control panel.</li> <li>• Brew Timer, located in the top control section under the top cover.</li> <li>• Brew Valve, located in the top control section under the top cover.</li> </ul>			
Problem	Possible Cause	Service Check	Remedy
<b>Brew volume too large or too small.</b>	Timer out of adjustment.	Compare timer setting to factory setting chart.	Adjust timer.
	Pressure not adequate at urn.	Fill valve should cycle on and off frequently during brew cycle when all brew heads are used.	If fill valve does not cycle or takes too long to refill, be sure water line is 3/8" and pressure is uninterrupted 30psi.
	Spray head clogged.	Visual	Clean all holes.
	Brew valves clogged with lime.	Visual, inspect brew valve.	Clean lime from valve. Seat cup or entire valve may need replacement.
	Timer faulty.	Brew time does match timer setting. Timer not adjustable.	Replace timer.
<b>Brew volume erratic. (there is always some small variation from batch to batch)</b>	Timer faulty.	Measure brew time for inconsistencies.	If time is different from batch to batch, replace timer.
	Pressure fluctuations at urn.	Check pressure at urn inlet.	Plumb water line so its pressure is not influenced by other appliances.
<b>Brew will not start.</b>	Circuit breaker tripped or faulty.	If circuit breaker button is out, breaker is tripped.	If tripped, find cause and reset. If faulty, replace.
	Brew valve faulty.	Check 120V across brew valve.	If 120V is across brew valve, but brew valve doesn't open, replace coil or valve.
	Stop switch faulty.	Check for continuity across stop switch when not pressed.	If no continuity, replace switch.
	Start switch faulty.	Check 120V between S.S. and N on timer when start is pressed.	If start switch does not provide 120V start signal, replace switch.
	Low temp/no brew thermostat set too high.	Water is above 190°F (88°C), but HOT WATER light is off.	Turn down brew thermostat, see adjustments.
	Timer faulty.	Check 120V between H and N on timer. If OK, check for 120V between BREW and N on timer after pressing start.	If no 120V BREW output from timer, replace timer.
<b>Spray head will not stop dripping water. (spray heads normally drip slightly after brew)</b>	Boiling tank.	If drip is from right side, check for water from overflow outlet at top of tank.	Turn down thermostat. If that doesn't cure, check for faulty thermostat or heater relay.
	Limed up brew valve.	Visual check of valve.	Clean valve. Valve seal or entire valve may need replacement.

## Parts Illustration for Models P300E & P400E

Item	Part #	Description	Item	Part #	Description
1	A545-034	LEG, 4" PLASTIC W/ SS FOOT	13	A725-081	BRASS SPRAY TEE W/ BYPASS TUBING
1	A545-015	LEG, 4" SS (OPTIONAL)	14	A530-009	BREW TIMER 0-8 MINUTES
2	A537-043	HOT WATER FAUCET W/ NUT	15	A585-021	SPRAY TUBING 3/8" ID X 5/8"OD X 6"LG
3	A531-035	TERMINAL BLOCK	16	A712-018	ELECTRODE ASSEMBLY
4	A531-026	TOGGLE SWITCH	17	A535-059	TANK HTR 6.6 KW @ 240V
5	A549-006	LIQUID LEVEL CONTROL BRD	18	A712-046	THERMOSTAT W/ GROMMET
6	APT400-105	SPRAY HEAD	19	A515027	DPST POWER RELAY
7	ACS-LL	SHUTTLE W/ LOCKING LID	20	A585-023	OVERFLOW TUBE 1/2"OD X 5/16"ID 7"LG
8	ABB1.5SS	BREW BASKET, SS	21	A515072	CIRCUIT BREAKER 10 AMP
9	A537-129	BREW VALVE	22	A718-111	BYPASS VALVE ASSEMBLY
10	A531-005	STOP SWITCH (before March 2000)	23	A718-198	FILL VALVE W/ FITTINGS (after 01-26-00)
10	A531-063	STOP SWITCH (after March 2000)	23	A537-154	FILL VALVE ONLY (after 01-26-00)
11	A531-004	START SWITCH (before March 2000)	23	A725-072	FILL VALVE RETROFIT KIT (before 01-26-00)
11	A531-062	START SWITCH (after March 2000)	24	A585-016	TUBING FILL 1.6' LG & HOT WATER 1.5' LG
12	A515016	PILOT LIGHT	25	A535-018	WARMER ELEMENT (below warmer shelf)

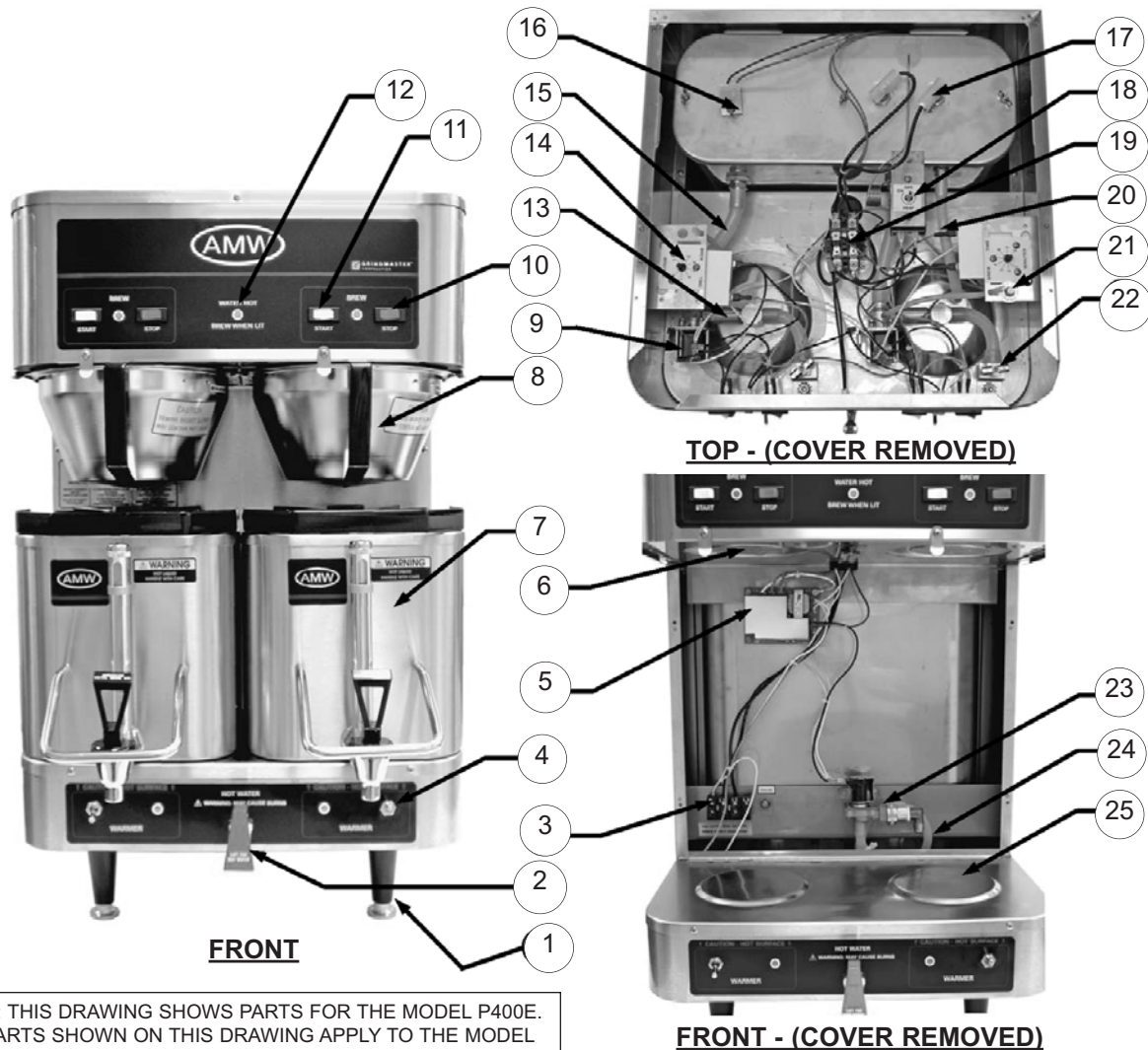

NOTE: THIS DRAWING SHOWS PARTS FOR THE MODEL P400E. ALL PARTS SHOWN ON THIS DRAWING APPLY TO THE MODEL P300E, EXCEPT THE QUANTITIES MAY CHANGE. DEPENDING ON THE OPTIONS INCLUDED, YOUR BREWER MAY HAVE DIFFERENT PARTS

## Parts Illustration for Model P400ESHP

Item	Part #	Description	Item	Part #	Description
1	A545-034	LEG, 4" PLASTIC W/ SS FOOT	15	A585-021	SPRAY TUBING 3/8" ID X 5/8"OD X 6"LG
1	A545-015	LEG, 4" SS (OPTIONAL)	16	A712-018	ELECTRODE ASSEMBLY
2	A537-043	HOT WATER FAUCET W/ NUT	17	A535-068	TANK HTR 3.7 KW @ 240V
3	A531-035	TERMINAL BLOCK	18	A712-046	THERMOSTAT W/ GROMMET
4	A531-026	TOGGLE SWITCH	19	A514005	CONTACTOR
5	A549-006	LIQUID LEVEL CONTROL BRD	20	A585-023	OVERFLOW TUBE 1/2"OD X 5/16"ID 7"LG
6	APT400-105	SPRAY HEAD	21	A515072	CIRCUIT BREAKER 10 AMP
7	ACS-LL	SHUTTLE W/ LOCKING LID	22	A718-111	BYPASS VALVE ASSEMBLY
8	ABB1.5SS	BREW BASKET, SS	23	A718-198	FILL VALVE W/ FITTINGS (after 01-26-00)
9	A537-129	BREW VALVE	23	A537-154	FILL VALVE ONLY (after 01-26-00)
10	A531-005	STOP SWITCH (before March 2000)	23	A725-072	FILL VALVE RETROFIT KIT (before 01-26-00)
10	A531-063	STOP SWITCH (after March 2000)	24	A585-016	TUBING FILL 1.6' LG & HOT WATER 1.5' LG
11	A531-004	START SWITCH (before March 2000)	25	A535-079	WARMER ELEMENT 240V (below warmer shelf)
11	A531-062	START SWITCH (after March 2000)	not shown	A515027	WARMER RELAY
12	A515016	PILOT LIGHT	not shown	A532-001	FUSE HOLDER
13	A725-081	BRASS SPRAY TEE W/ BYPASS TUBING	not shown	A532-010	FUSE 1A
14	A530-009	BREW TIMER 0-8 MINUTES	not shown	A515043	TRASFORMER STEP DOWN

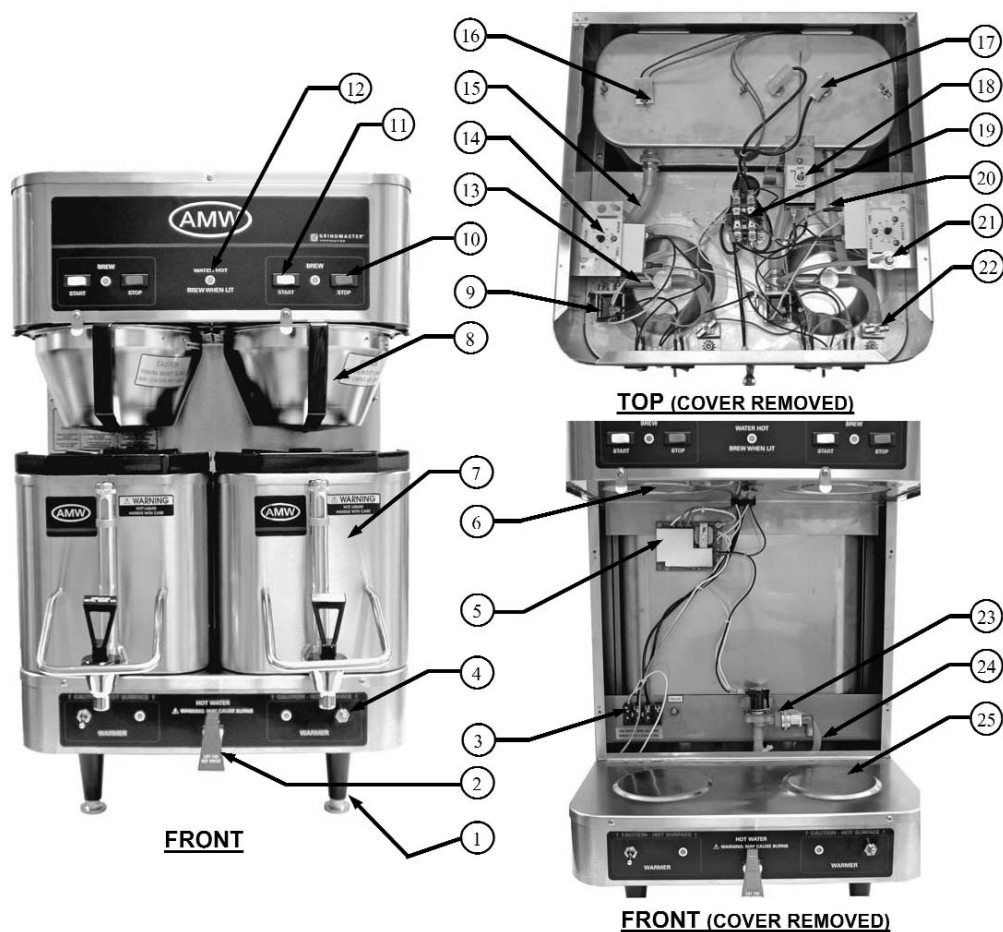

# Parts Illustration for Model RAP400E

Item	Part #	Description	Item	Part #	Description
1	A548-072	LEG, RUBBER (RAP400)	11	A515016	PILOT LIGHT
1	A545-004	LEG, PLASTIC 4" (OPTIONAL RAP 400)	12	A725-082	SPRAY TEE KIT W/ BYPASS PLUG
1	A548-090	LEG, PLASTIC PLUG (RAP300)	13	A530-009	BREW TIMER 0-8 MINUTES
2	A531-035	TERMINAL BLOCK	14	A585-021	SILICONE TUBING 3/8"ID X 5/8"OD X 6"LG
3	A549-006	LIQUID LEVEL BOARD	15	A712-018	ELECTRODE ASSEMBLY
4	AAP-3	AIRPOT	16	A535-059	TANK HTR 6.6 KW @ 240V
5	APT400-105	SPRAY HEAD	17	A712-046	THERMOSTAT W/ GROMMET
6	ABB1.5P	BREW BASKET, PLASTIC	18	A515027	POWER RELAY
7	A537-129	BREW VALVE	19	A585-023	OVERFLOW TUBE 1/2"OD X 5'16ID X 7LG
8	A531-005	STOP SWITCH (before March 2000)	20	A515072	CIRCUIT BREAKER 10 AMP
8	A531-063	STOP SWITCH (after March 2000)	21	A718-198	FILL VALVE W/ FITTINGS (after 01-26-00)
9	A531-004	START SWITCH (before March 2000)	21	A537-154	FILL VALVE ONLY (after 01-26-00)
9	A531-062	START SWITCH (after March 2000)	21	A725-072	FILL VALVE RETROFIT KIT (before 01-26-00)
10	A537-043	HOT WATER FAUCET	22	A585-016	TUBING FILL 1.6' LG & HOT WATER 3.75' LG

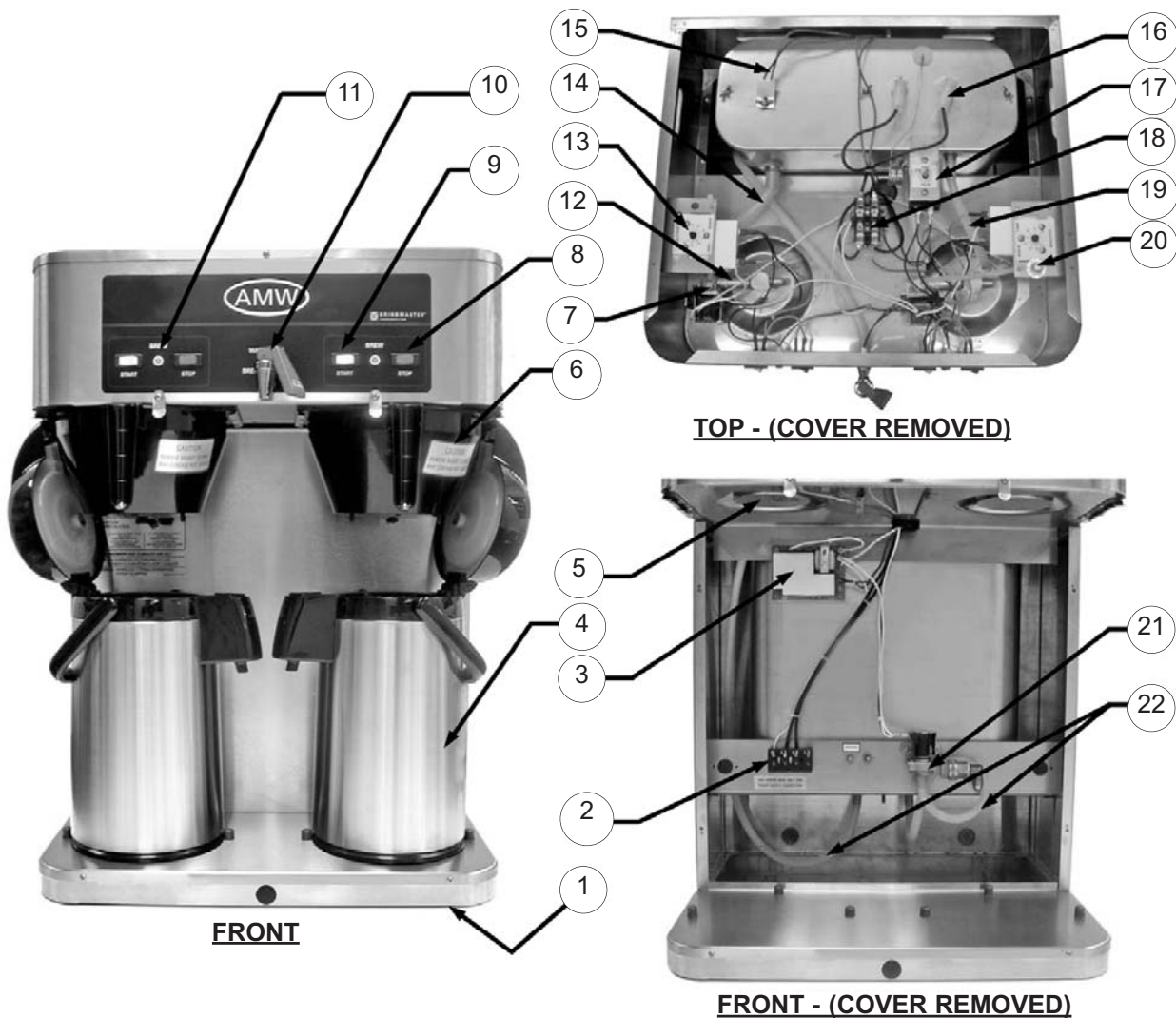

# Parts Illustration for Model RAPS400E

Item	Part #	Description	Item	Part #	Description
1	A545-034	LEG, 4" PLASTIC W/ SS FOOT	16	A725-081	BRASS SPRAY TEE W/ BYPASS TUBING
1	A545-015	LEG, 4" SS (OPTIONAL)	17	A585-021	SPRAY TUBING 3/8" ID X 5/8"OD X 6"LG
2	A537-043	HOT WATER FAUCET W/ NUT	18	A712-018	ELECTRODE ASSEMBLY
3	A531-035	TERMINAL BLOCK	19	A535-010	TANK HEATER 5KW @ 240V
4	AABW-R	ACCESSORY WARMER RIGHT	20	A712-046	THERMOSTAT W/ GROMMET
5	AAP-3	AIRPOT 3 LITER	21	A515027	DPST POWER RELAY
6	A549-006	LIQUID LEVEL CONTROL BOARD	22	A585-023	OVERFLOW TUBE 1/2"OD X 5/16"ID 7"LG
7	APT400-105	SPRAY HEAD	23	A515072	CIRCUIT BREAKER 10 AMP
8	ACS-LL	SHUTTLE W/ LOCKING LID	24	A530-016	1/2 BATCH CUBE TIMER
9	ABB1.5SS	BREW BASKET, STAINLESS STEEL	25	A718-111	BYPASS VALVE ASSEMBLY
10	A537-129	BREW VALVE	26	A531-025	MOMENTARY SWITCH
11	A531-005	STOP SWITCH (before March 2000)	27	A718-198	FILL VALVE W/ FITTINGS (after 01-26-00)
11	A531-063	STOP SWITCH (after March 2000)	27	A537-154	FILL VALVE ONLY (after 01-26-00)
12	A531-004	START SWITCH (before March 2000)	28	A515062	FUSE HOLDER
12	A531-062	START SWITCH (after March 2000)	29	A532-002	FUSE CLASS G 3 AMP
13	A550-159	BATCH SELECTOR SWITCH	30	A585-016	TUBING FILL 1.6' LG & HOT WATER 1.5' LG
14	A515016	PILOT LIGHT	31	A550-279	SINGLE RECEPTACLE NEMA 5-15R GFCI
15	A554-043	POTENTIOMETER			

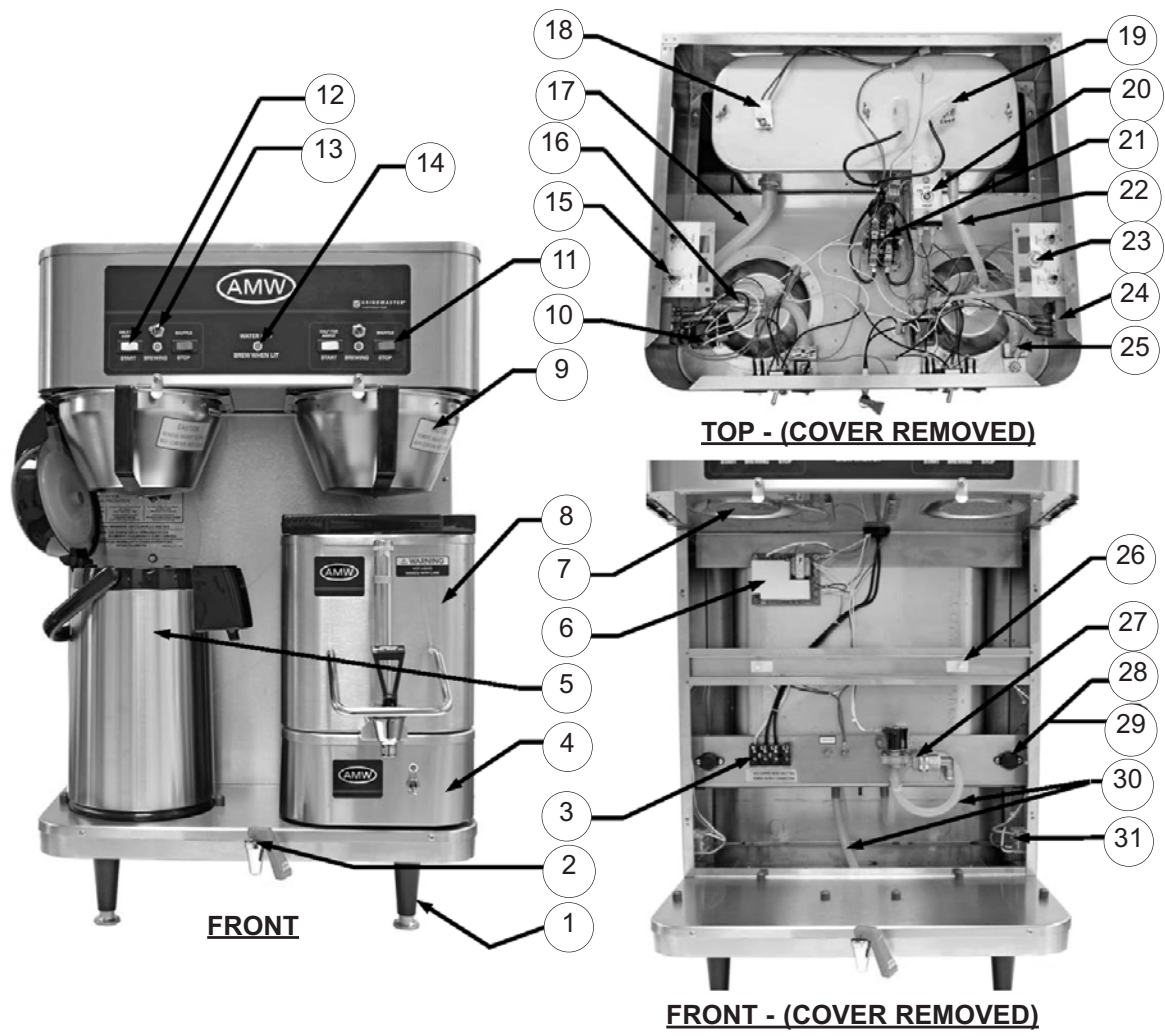

## Parts Illustration for Model VSB-400

Item	Part #	Description	Item	Part #	Description
1	A545-034	LEG, 4" PLASTIC W/ SS FOOT	12	A725-081	SPRAY TEE KIT W/ BYPASS TUBING
1	A545-015	LEG, 4" SS (OPTIONAL)	13	A530-009	BREW TIMER 0-8 MINUTES
2	A531-035	TERMINAL BLOCK	14	A585-021	SILICONE TUBING 3/8"ID X 5/8"OD X 6"LG
3	A549-006	LIQUID LEVEL BOARD	15	A712-018	ELECTRODE ASSEMBLY
4	AVS-1.5	SHUTTLE VACUUM	16	A535-059	TANK HEATER 6.6 KW @ 240V
5	APT400-105	SPRAY HEAD	17	A712-046	THERMOSTAT W/ GROMMET
6	ABB1.5P	BREW BASKET, PLASTIC	18	A515027	POWER RELAY
7	A537-129	BREW VALVE	19	A585-023	OVERFLOW TUBE 1/2"OD X 5/16"ID 7"LG
8	A531-005	STOP SWITCH (before March 2000)	20	A515072	CIRCUIT BREAKER 10AMP
8	A531-063	STOP SWITCH (after March 2000)	21	A718-111	BYPASS VALVE ASSEMBLY
9	A531-004	START SWITCH (before March 2000)	22	A718-198	FILL VALVE W/ FITTINGS (after 01-26-00)
9	A531-062	START SWITCH (after March 2000)	22	A537-154	FILL VALVE ONLY (after 01-26-00)
10	A537-043	HOT WATER FAUCET	22	A725-072	FILL VALVE RETROFIT KIT (before 01-26-00)
11	A515016	PILOT LIGHT	23	A585-016	TUBING FILL 1.6' LG & HOT WATER 1.5' LG

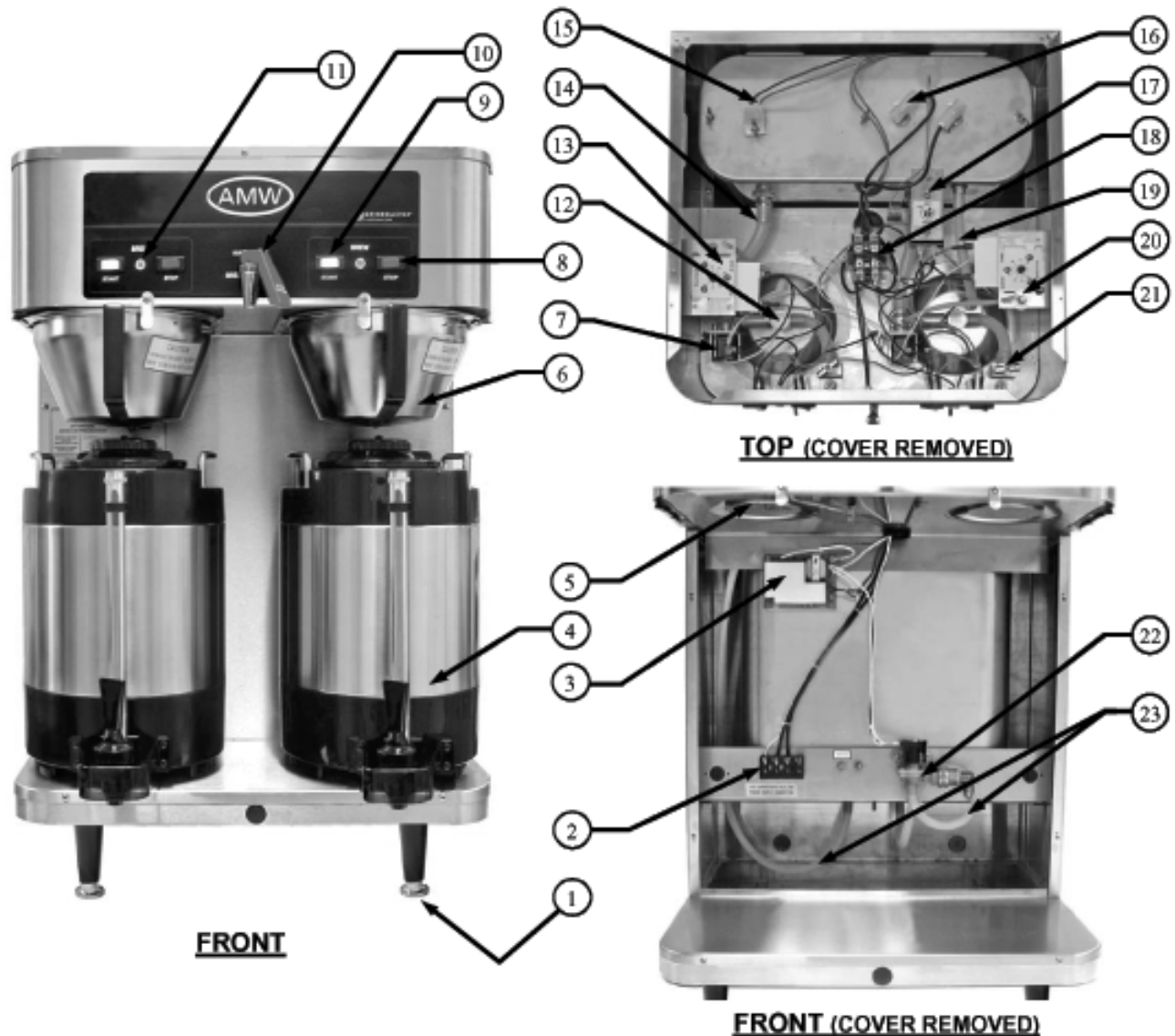

# Parts Illustration for Shuttle CS-LL

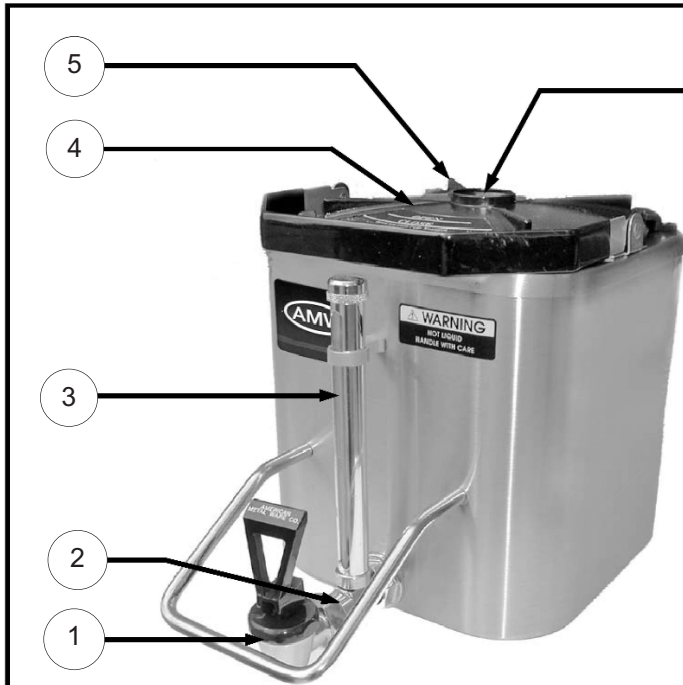

Item	Part #	Description
1	<a href="#">A537-053</a>	FAUCET MODEL ES
2	<a href="#">A522078</a>	SHANK W/ CHROME BONNET
3	<a href="#">A718-018</a>	GAUGE ASSEMBLY
4	<a href="#">A725-092</a>	KIT, SHUTTLE LID
	<a href="#">A713-027</a>	SS SHUTTLE COVER (not shown)*
5	<a href="#">A548-142</a>	LID RETAINING CLIP
6	<a href="#">A548-140</a> <a href="#">A61365</a>	LID STOPPER W/ O-RING

\* S.S. Cover used until August 2001

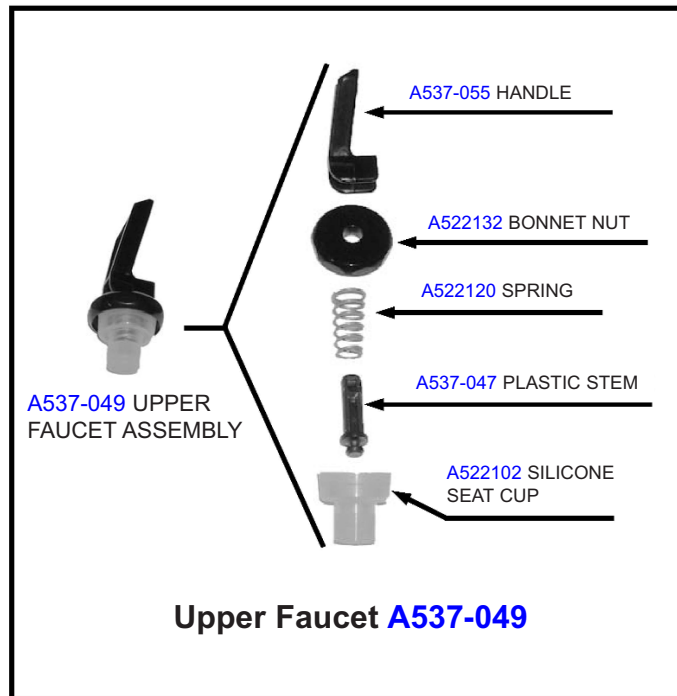

**A537-049** UPPER FAUCET ASSEMBLY

- [A537-055](#) HANDLE
- [A522132](#) BONNET NUT
- [A522120](#) SPRING
- [A537-047](#) PLASTIC STEM
- [A522102](#) SILICONE SEAT CUP

**Upper Faucet [A537-049](#)**

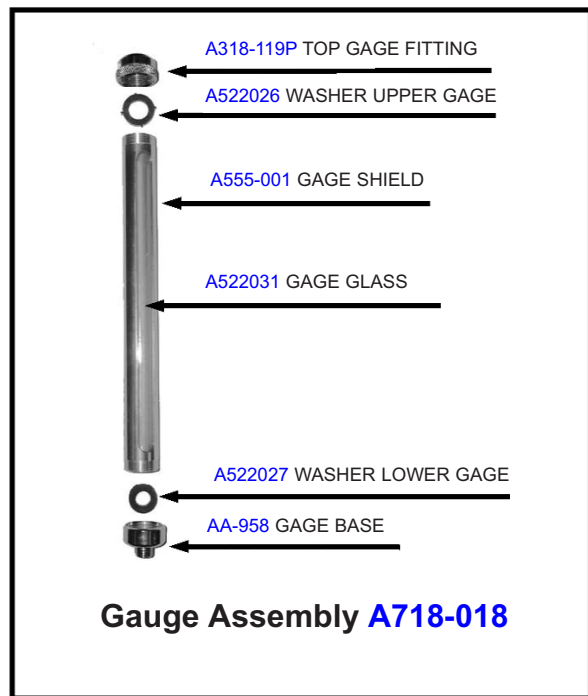

- [A318-119P](#) TOP GAGE FITTING
- [A522026](#) WASHER UPPER GAGE
- [A555-001](#) GAGE SHIELD
- [A522031](#) GAGE GLASS
- [A522027](#) WASHER LOWER GAGE
- [AA-958](#) GAGE BASE

**Gauge Assembly [A718-018](#)**

# Rough-In Drawing for Model P-300

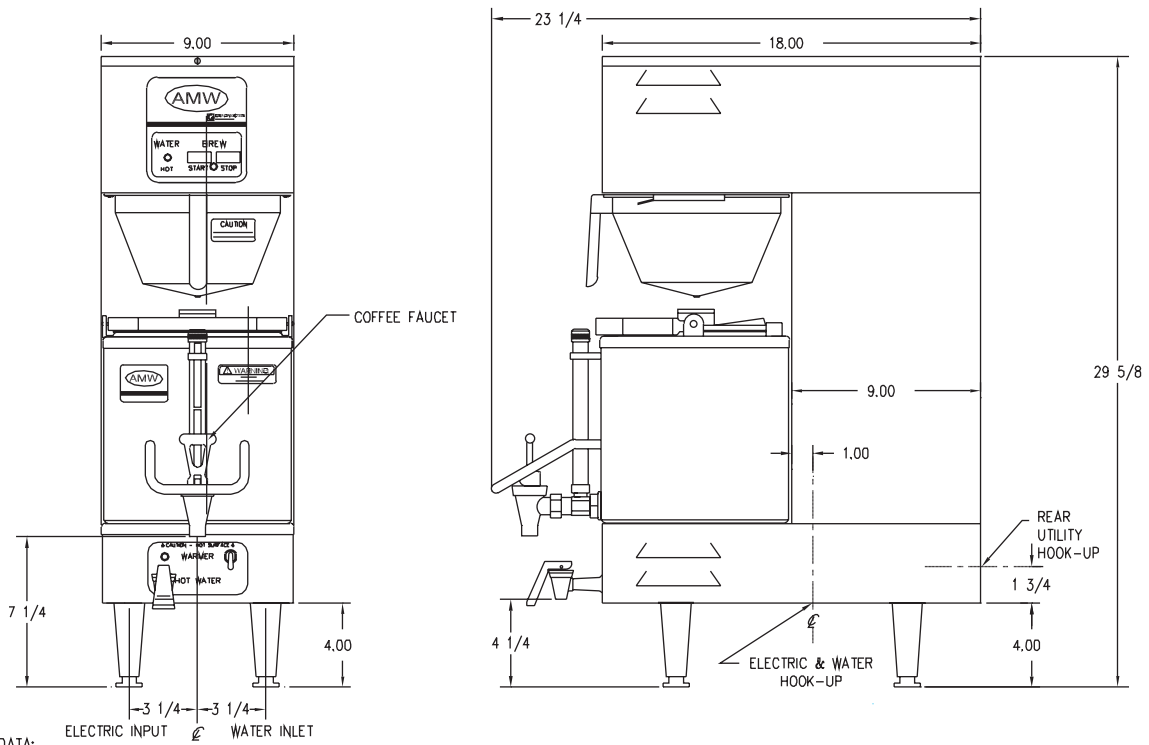

**UTILITY DATA:**  
**ELECTRIC**  
 6.6 KW 120/240 VOLT 1 PHASE 3 WIRE 28 AMPS  
 OR 5 KW 120/208 VOLT 1 PHASE 3 WIRE 24 AMPS  
 REAR OR BOTTOM HOOK-UP  
**WATER**  
 3/8" FLARE REAR OR BOTTOM HOOK-UP

**NOTES:**  
 1. ALL DIMS ARE IN INCHES

# Rough-In Drawing for Model P-400 & P-400ESHP

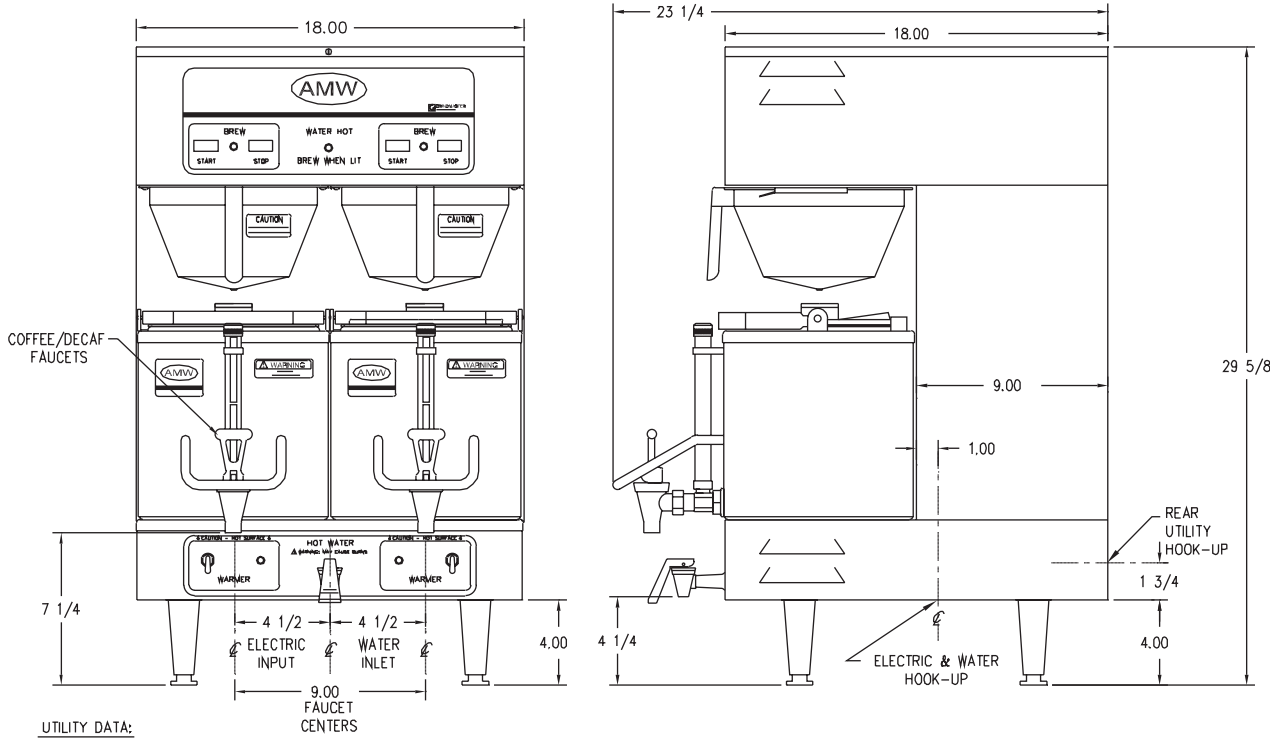

UTILITY DATA:  
ELECTRIC  
 6.6 KW 120/240 VOLT 1 PHASE 3 WIRE 28 AMPS  
 OR 5 KW 120/208 VOLT 1 PHASE 3 WIRE 24 AMPS  
 REAR OR BOTTOM HOOK-UP  
WATER  
 3/8" FLARE REAR OR BOTTOM HOOK-UP

NOTES:  
 1. ALL DIMS ARE IN INCHES

# Rough-In Drawing for Model RAP-300

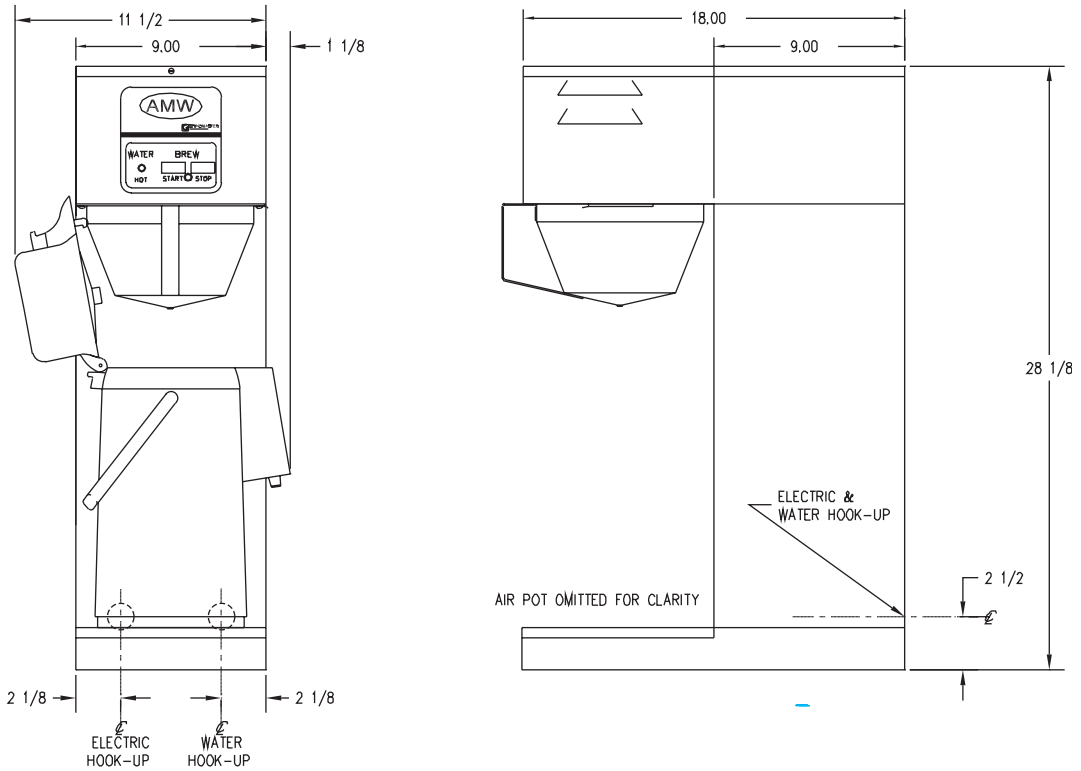

**UTILITY DATA:**  
**ELECTRIC**  
 6.6KW T20/240 VOLT 1 PHASE 3 WIRE 28 AMPS  
 OR 5KW 120/208 VOLT 1 PHASE 3 WIRE 24 AMPS  
 REAR HOOK-UP ONLY  
**WATER**  
 3/8" FLARE REAR HOOK-UP ONLY

**NOTES:**  
 1. ALL DIMS ARE IN INCHES

# Rough-In Drawing for Model RAP-400

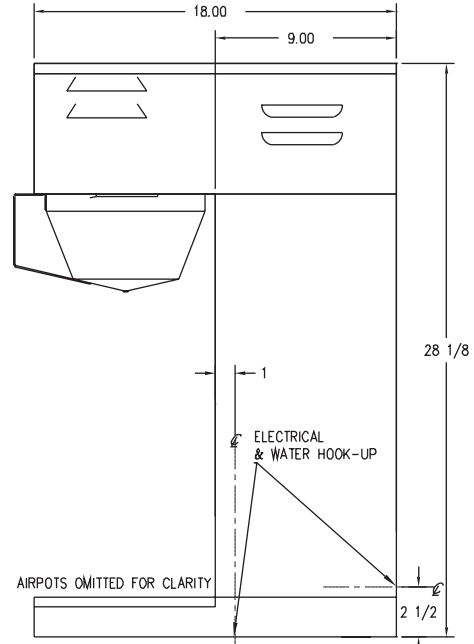
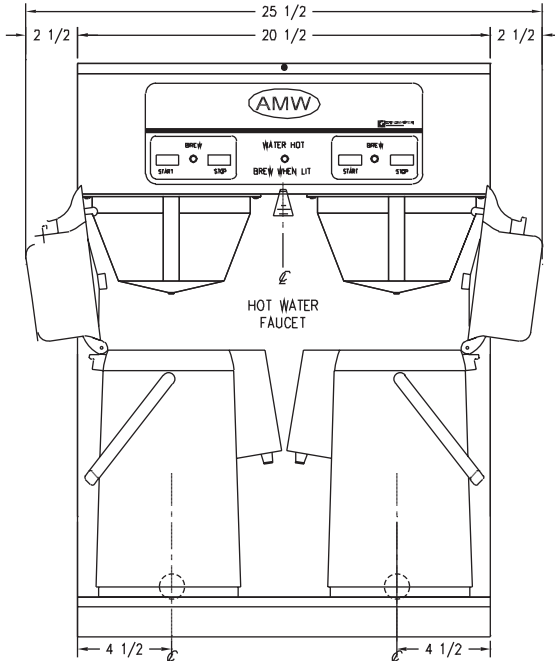

UTILITY DATA:  
 ELECTRIC  
 6.6KW 120/240 VOLT 1 PHASE 3 WIRE 28 AMPS  
 OR 5KW 120/208 VOLT 1 PHASE 3 WIRE 24 AMPS  
 REAR HOOK-UP ONLY (BOTTOM HOOK-UP WITH OPTIONAL 4" LEGS)  
 WATER  
 3/8" FLARE REAR HOOK-UP ONLY  
 (BOTTOM HOOK-UP WITH OPTIONAL 4" LEGS)

# Rough-In Drawing for Model RAPS-300

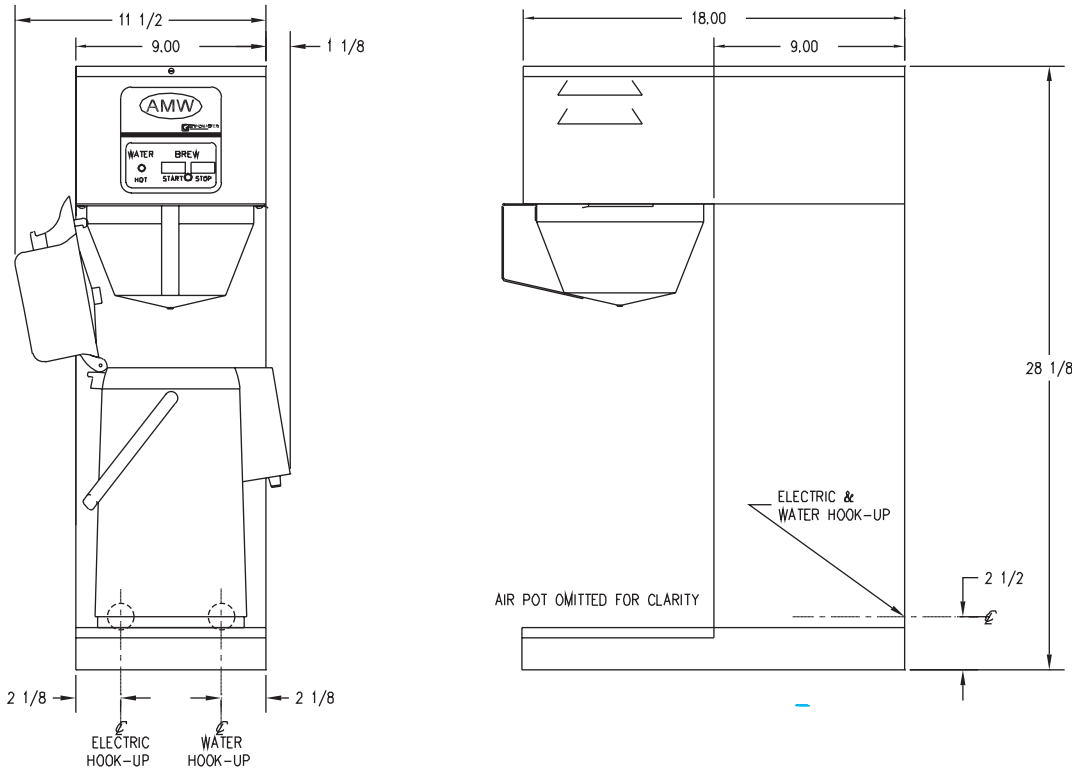

**UTILITY DATA:**  
**ELECTRIC**  
 6.6KW T20/240 VOLT 1 PHASE 3 WIRE 28 AMPS  
 OR 5KW 120/208 VOLT 1 PHASE 3 WIRE 24 AMPS  
 REAR HOOK-UP ONLY  
**WATER**  
 3/8" FLARE REAR HOOK-UP ONLY

**NOTES:**  
 1. ALL DIMS ARE IN INCHES



# Rough-In Drawing for Model VSB-300

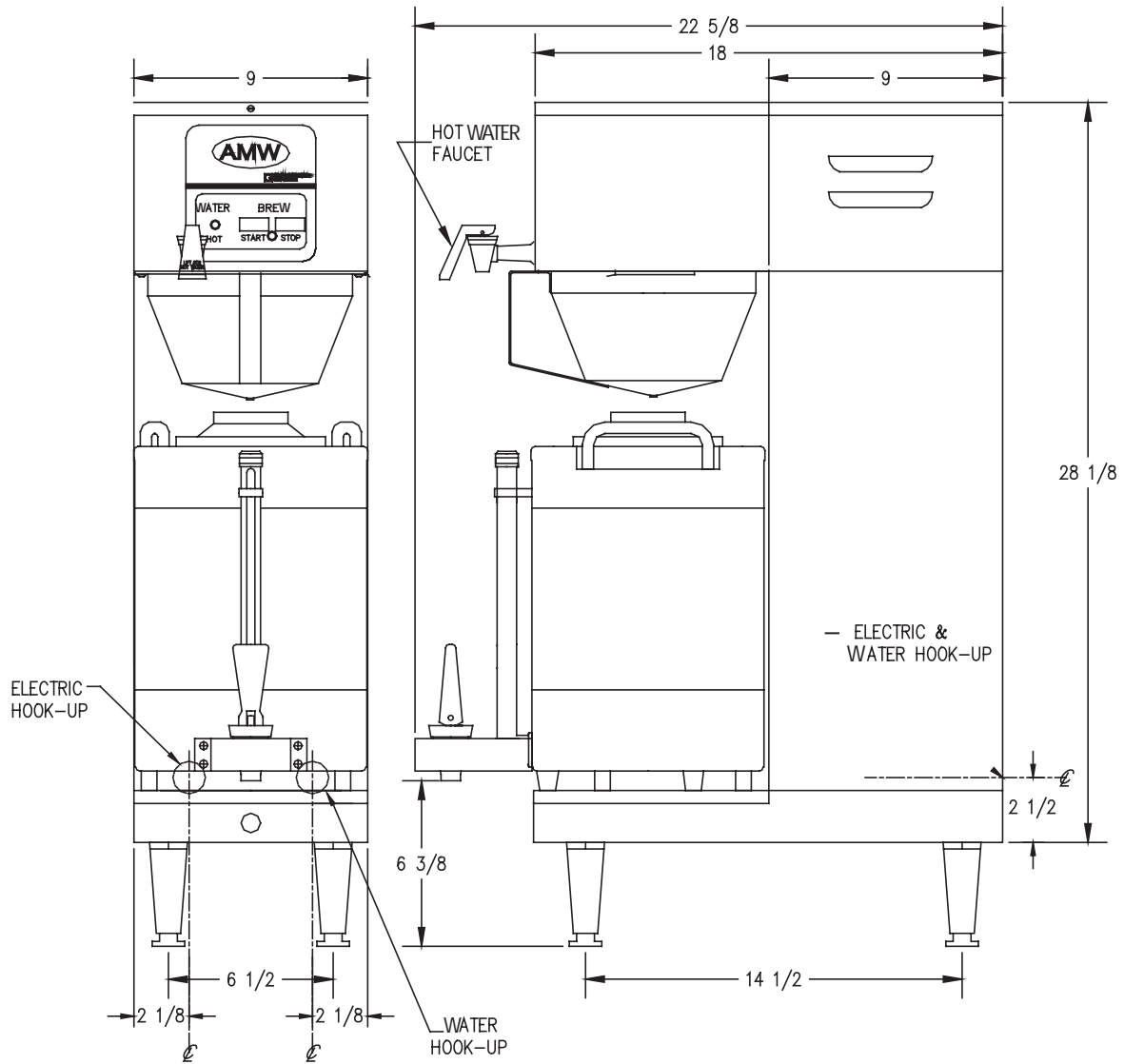

UTILITY DATA:

ELECTRIC

6.6KW 120/240 VOLT 1 PHASE 3 WIRE 28 AMPS  
 OR 5KW 120/208 VOLT 1 PHASE 3 WIRE 24 AMPS  
 REAR HOOK-UP ONLY

WATER

3/8" FLARE REAR HOOK-UP ONLY

NOTES:

1. ALL DIMS ARE IN INCHES

# Rough-In Drawing for Model VSB-400

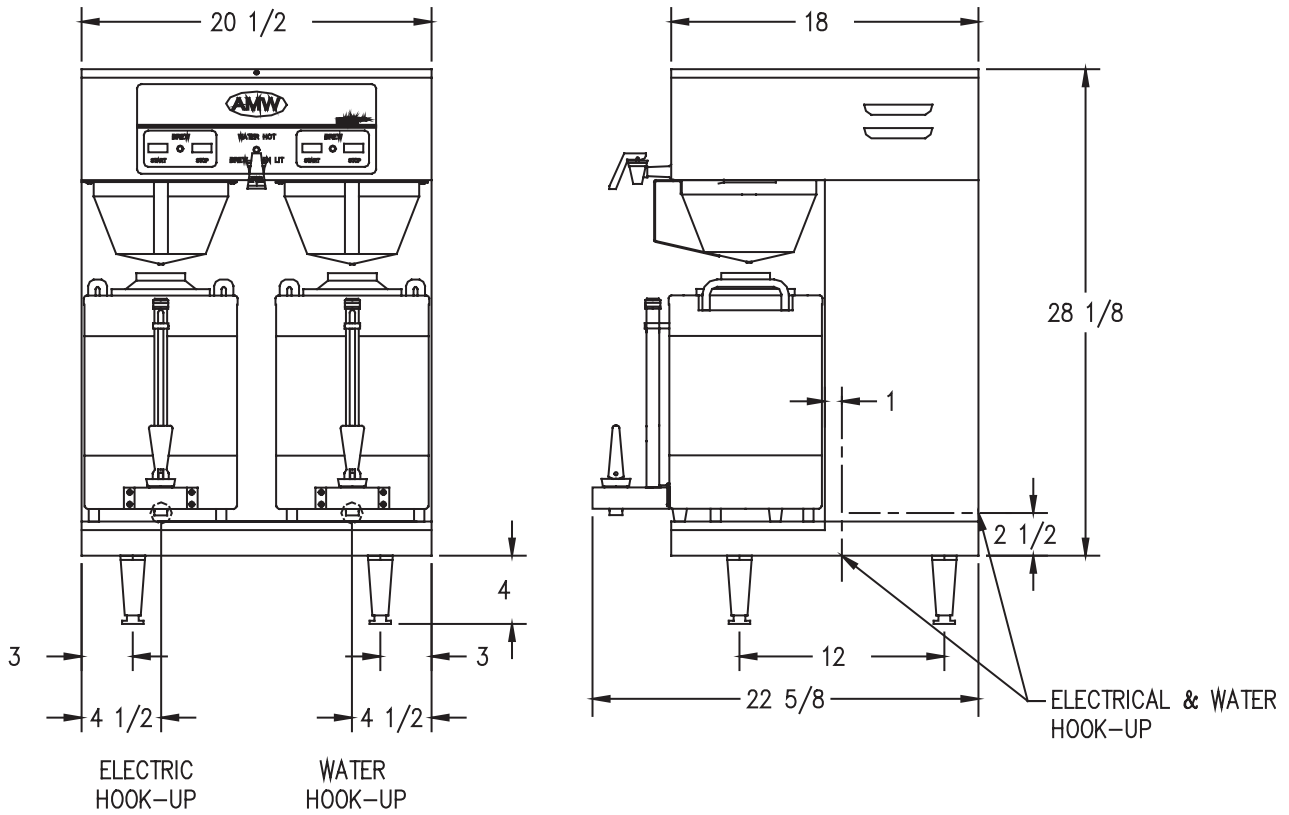

**UTILITY DATA:**

ELECTRIC

6.6KW 120/240 VOLT 1 PHASE 3 WIRE 28 AMPS  
OR 5KW 120/208 VOLT 1 PHASE 3 WIRE 24 AMPS  
BOTTOM OR REAR HOOK-UP

WATER

3/8" FLARE BOTTOM OR REAR HOOK-UP

**NOTES:**

1. ALL DIMS ARE IN INCHES

# Wiring Diagram for P300E/P400E, with 1 Batch Timer

NOTE: THIS DRAWING SHOWS COMPONENTS ON STANDARD MODEL ONLY. SEE 091-548 FOR WIRING OF BREWER OPTIONS

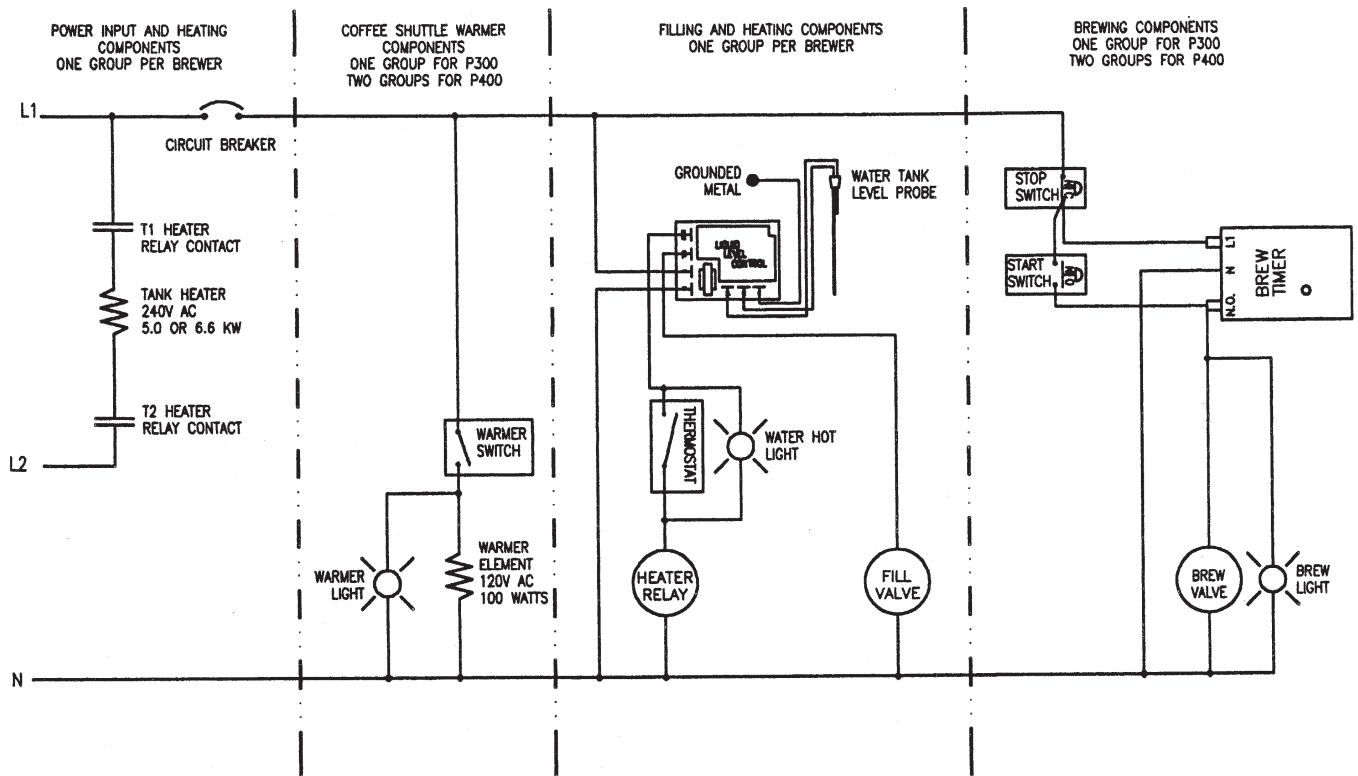

# Wiring Diagram for P300E/P400E, with 2 Batch Timer

NOTE: THIS DRAWING SHOWS COMPONENTS ON STANDARD MODEL ONLY. SEE 091-548 FOR WIRING OF BREWER OPTIONS

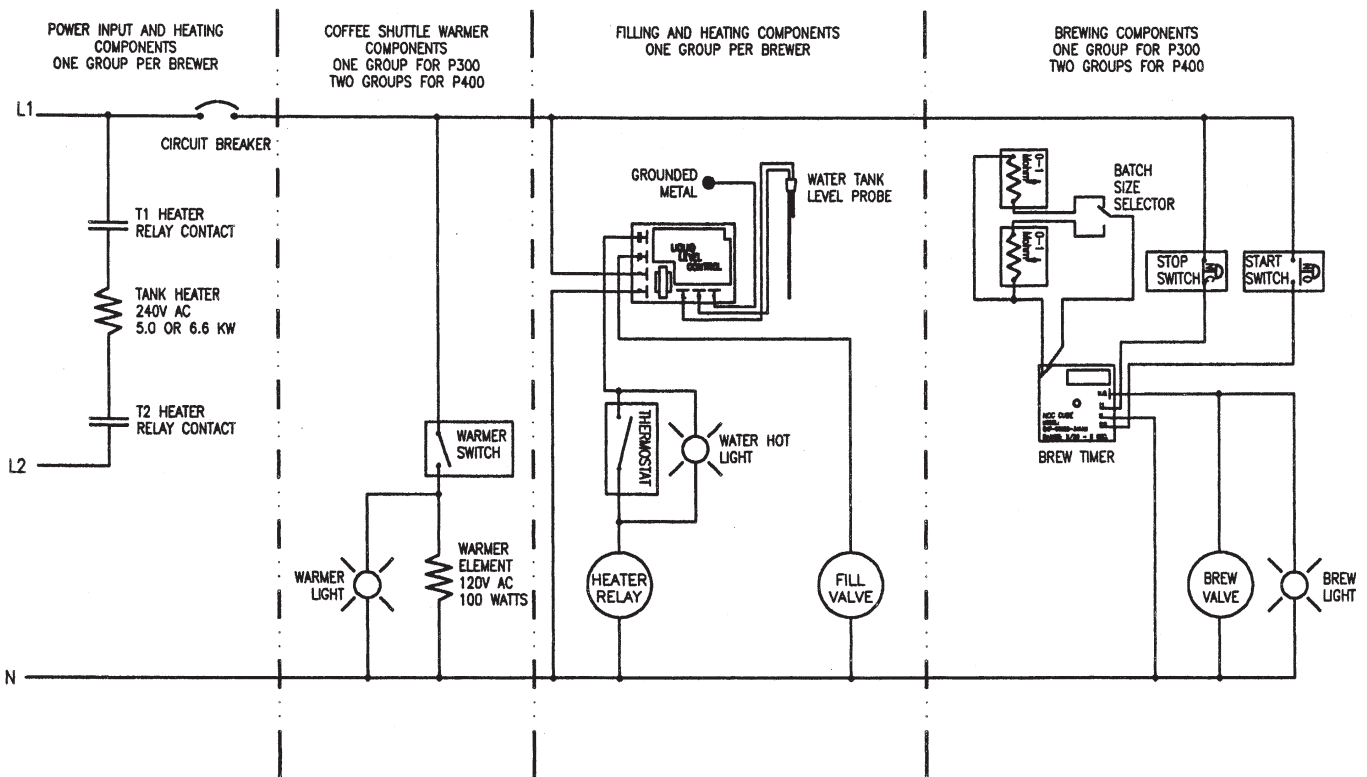

# Wiring Diagram for RAP300E/400E

NOTE: THIS DRAWING SHOWS COMPONENTS ON STANDARD MODEL ONLY. SEE 091-548 FOR WIRING OF BREWER OPTIONS

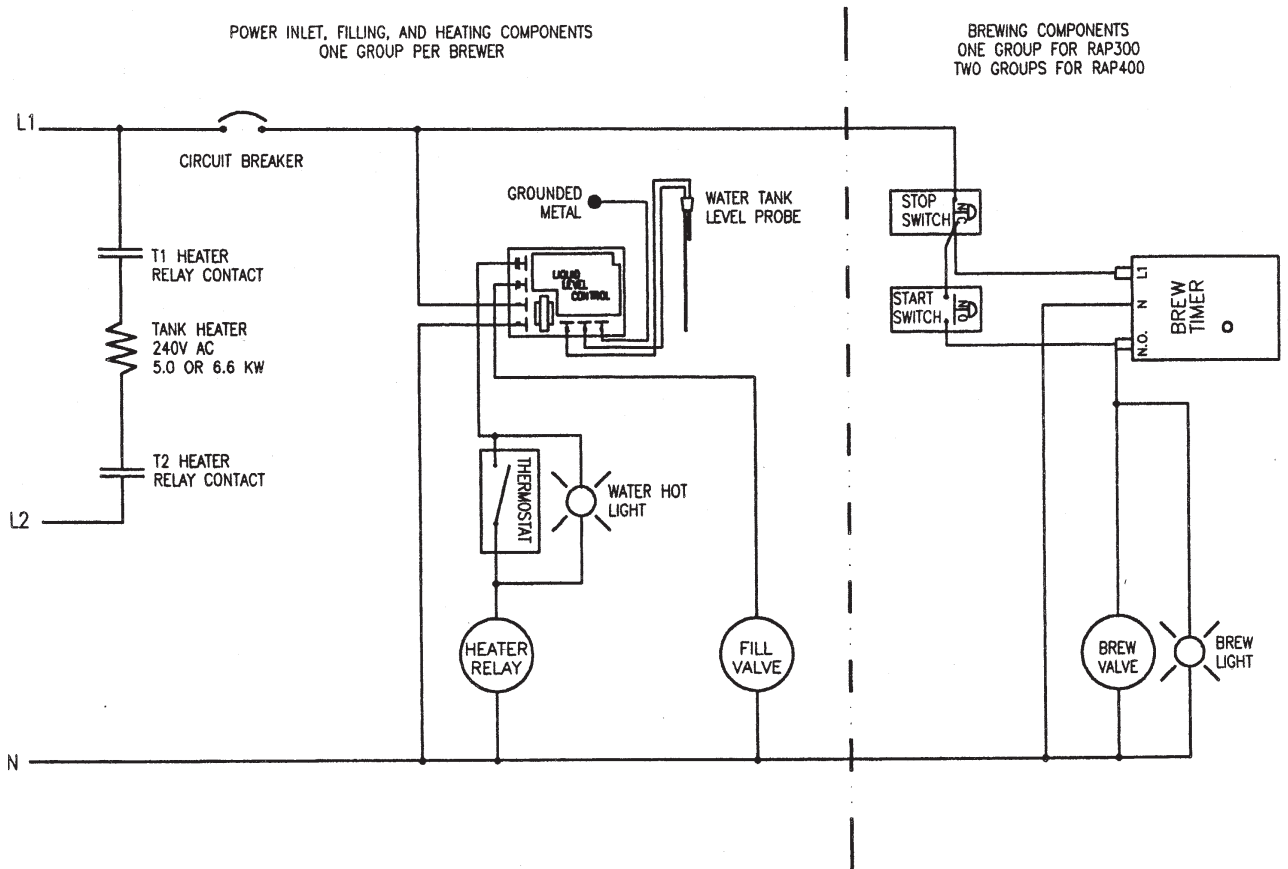

# Wiring Diagram for RAPS 300/400E

**NOTE:**  
 1) TWO SETS OF RECEPTACLE COMPONENTS ONLY PROVIDED ON TWIN RAPS400E MODEL. DELETE GROUP IN DASHED BOX FOR RAPS300E.  
 2) THIS DIAGRAM SHOWS COMPONENTS ON STANDARD MODEL ONLY. SEE 091-548 FOR WIRING OF BREWER OPTIONS.

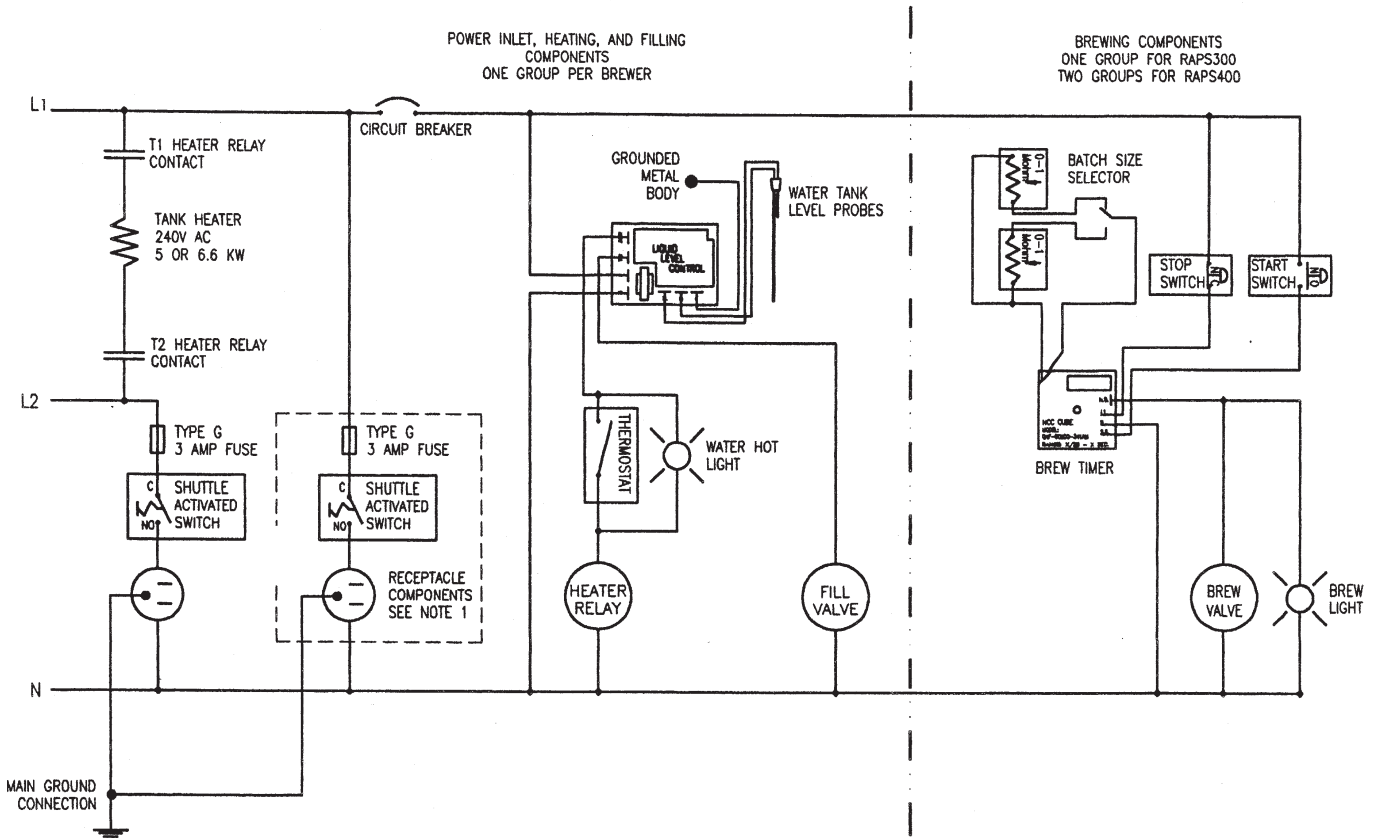

Drawing #091-523

# Wiring Diagram for P-400ESHP

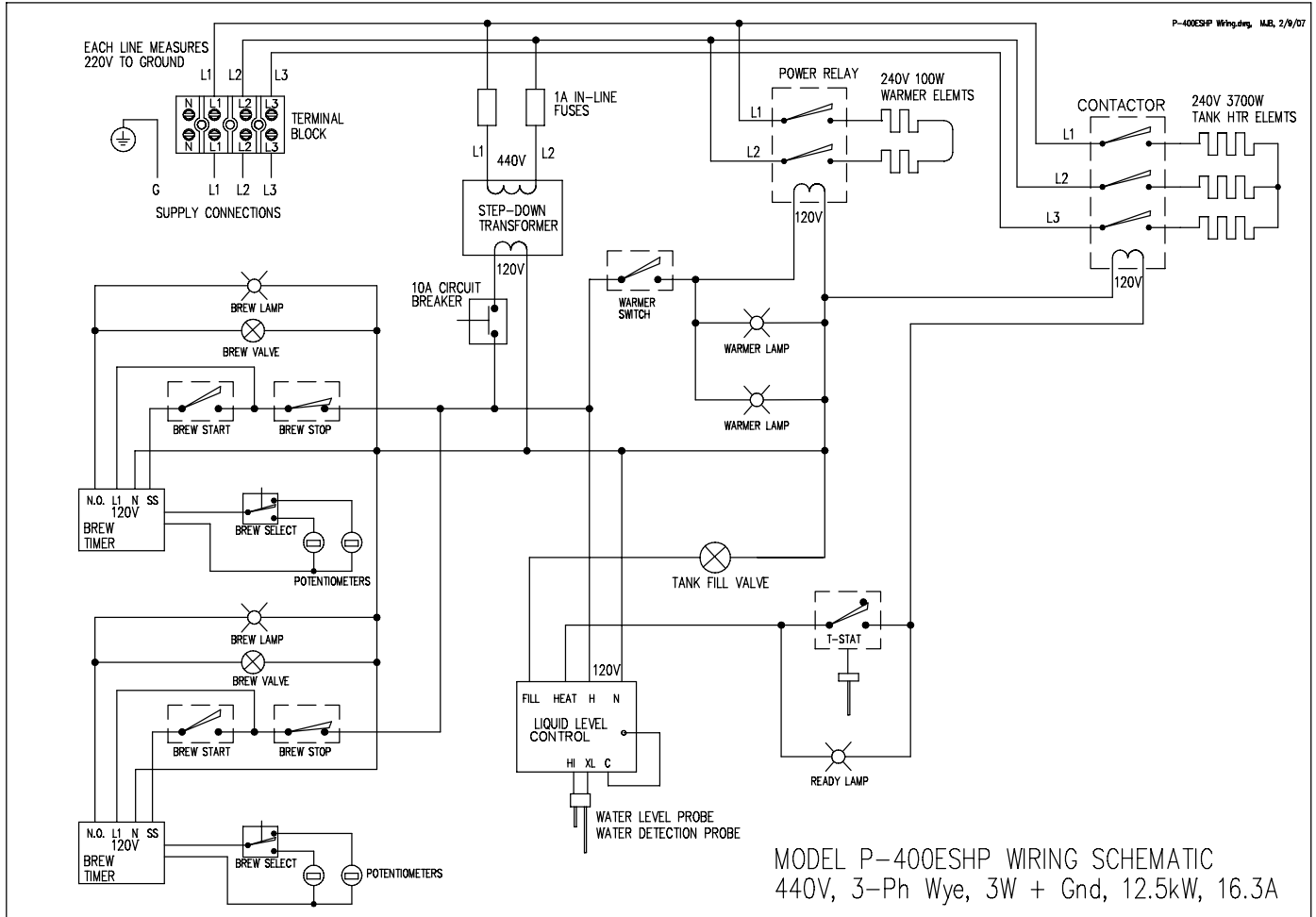

# Wiring Diagram #091-548

**NOTE:**

- 1) ONE GROUP OF WARMER COMPONENTS PER BREW HEAD ON P AND RAPS MODELS.
- 2) TRANSFORMER MUST BE USED WHEN NEUTRAL LINE IS NOT PROVIDED.
- 3) IF MODEL RAP, DELETE WARMER COMPONENTS.
- 4) IF MODEL IS RAPS, DELETE WARMER LIGHT AND REPLACE WARMER ELEMENT WITH NEMA 6-15 RECEPTACLE.

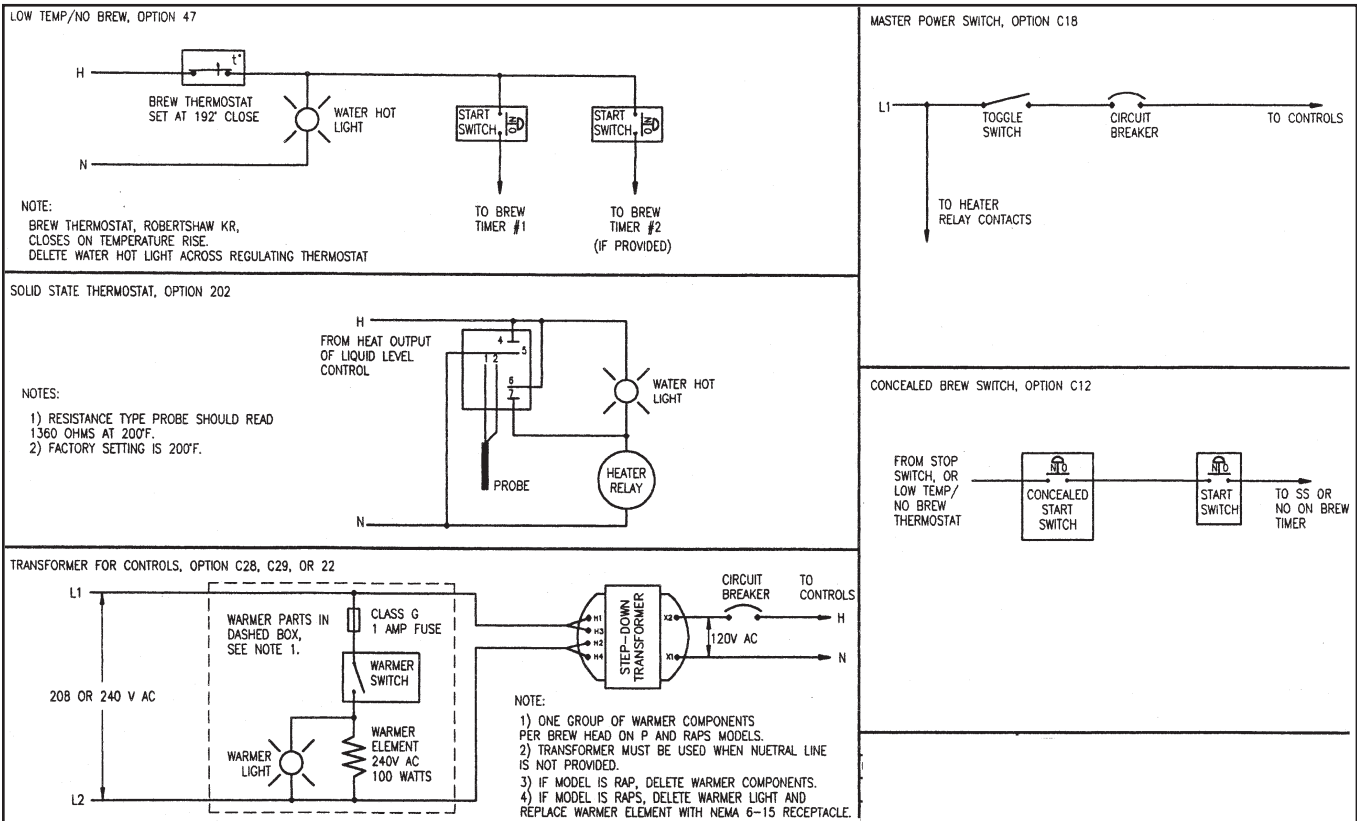

**NOTES:**

- 1) IF PROVIDED WITH OPTION C21A, THREE HEATERS, SEE HEATER WIRING DIAGRAM 091-182.
- 2) WHEN PROVIDED WITH OPTION C14, AUTOMATIC WARMER SHUTOFF, SUBSTITUTE ACTIVATED SWITCH FOR WARMER TOGGLE.

# Wiring Diagram #091-182

NOTE: USE WIRE NUT FOR ① - ① CONNECTION

T3	T3	T3	①	①	T4	A
T2	T3	T3	T4	T4	T4	B
T2	T3	T3	①	①	T1	C
T3	T3	T3	T1	T1	T4	D
T2	T3	T3	T1	T1	T4	E
T2	T3	T3	T1	T1	T2	F

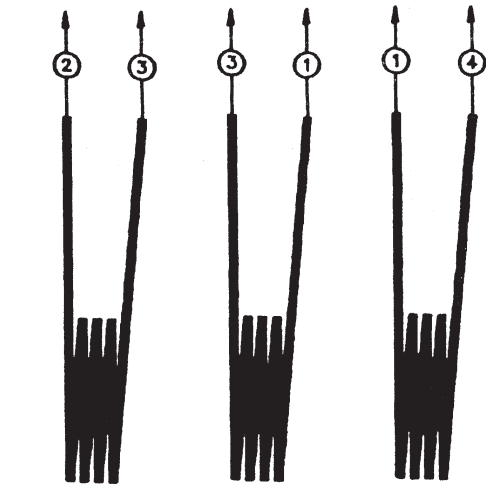
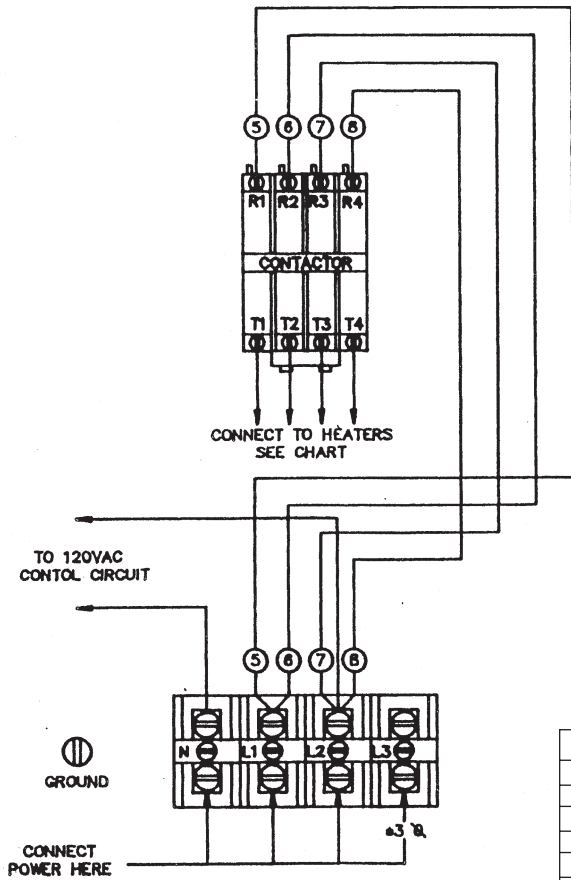

## 5000 WATT / 240V HEATERS

FOR THIS HEAT AND ELECTRIC SERVICE	WIRE PER FIG.
2.0 KW - 120/208V - 1 PH - 3 WIRE - 9 AMPS	A
2.5 KW - 120/240V - 1 PH - 3 WIRE - 11 AMPS	
4.0 KW - 120/208V - 1 PH - 3 WIRE - 18 AMPS	
5.0 KW - 120/240V - 1 PH - 3 WIRE - 21 AMPS	B
5.5 KW - 120/208V - 1 PH - 3 WIRE - 27 AMPS	C
7.5 KW - 120/240V - 1 PH - 3 WIRE - 31 AMPS	
7.5 KW - 120/208V - 1 PH - 3 WIRE - 38 AMPS	D
10.0 KW - 120/240V - 1 PH - 3 WIRE - 42 AMPS	
11.5 KW - 120/208V - 1 PH - 3 WIRE - 54 AMPS	E
15.0 KW - 120/240V - 1 PH - 3 WIRE - 63 AMPS	
11.5 KW - 120/208V - 3 PH - 4 WIRE - 31 AMPS	F
15.0 KW - 240V - 3 PH - 3 WIRE - 36 AMPS *	

\* SEPARATE 120V REQUIRED FOR CONTROLS (3 AMP LOAD)

\* FOR 3 PHASE WIRING

1. MOVE WIRE ⑥ FROM L1 TO L3
2. CONNECT HEATER ACCORDING TO FIG. F ON CHART
3. FIG. F FOR 3 PH ONLY

WIRES ⑤⑥⑦⑧ ARE 8 AWG, 105°C

①②③④ ARE 10 AWG, 105°C



**GRINDMASTER™**

C O R P O R A T I O N

---

Grindmaster® Coffee Grinders and Brewers • PrecisionBrew™ Brewing Systems • Espresso® Espresso Machines  
Crathco® Hot Beverage Dispensers • Crathco® Cold and Frozen Beverage Dispensers • AMW Coffee and Tea Systems  
Tel (502) 425-4776 • Fax (502) 425-4664 • 1-800-695-4500 (USA & Canada only)

P.O. Box 35020 • Louisville, KY 40232 • USA

© Grindmaster Corporation, 1998  
PRINTED IN USA

[www.grindmaster.com](http://www.grindmaster.com) • email: [info@grindmaster.com](mailto:info@grindmaster.com)

0307 Form # AM-309-08  
Part # 090-077