



Cecilware®

Operator Manual

TB Series Iced Tea Brewers & Dispensers

Models TB3, B1/3, B1/3T, SU3P



**Model B1/3
Dispenser w/ Base**



**Model TB3 Brewer
w/ B1/3T Dispenser**



**Model SU3P
Dispenser w/ Base**



**Model B1/3T
Dispenser w/ no Base**



Table of Contents

Safety Information.....2	Maintenance6
Specifications.....3	Troubleshooting Guide.....9
Installation.....4	Parts Diagram and List10
Operation4	Wiring Diagram.....14
Cleaning.....5	

Thank you for purchasing this quality tea brewer or dispenser. For your safety and the safety of others, read all warnings and the operator's manual before installing or using the product. Properly instruct all operators. Keep training records. For future reference, record serial number here:

Grindmaster-Cecilware™
4003 Collins Lane, Louisville, KY 40245 USA
Phone: 502.425.4776 Toll Free: 800.695.4500
Fax: 502.425.4664
Web: gmcw.com Email: info@gmcw.com

Grindmaster-Cecilware provides the industry's BEST warranty. Visit gmcw.com for warranty terms and conditions.



**Grindmaster
Cecilware**

Safety Information

Important Safety Information



This is the safety alert symbol. It is used to alert you to potential personal injury hazards. Obey all safety messages that follow this symbol to avoid possible injury or death.

For your safety and the safety of others, read all warnings and the operator's manual before installing or using the product.

DANGER: This term warns the user of imminent hazard that will result in serious injury or death.

WARNING: This term refers to a potential hazard or unsafe practice, which could result in serious injury or death.

CAUTION: This term refers to a potential hazard or unsafe practice, which could result in minor or moderate injury.

NOTICE: This term refers to information that needs special attention or must be fully understood.

WARNING

- Product must be attached to a three wire 120V 15 AMP receptacle.
- Do not deform plug or cord.
- Follow national and local electrical codes.
- Do not use near combustibles.
- Use only on a circuit load that is properly protected and capable of the rated load.
- Always unplug unit from power supply before servicing or cleaning.
- If the main power supply cord is damaged, it must be replaced by the manufacturer, its service agent or a similar qualified person in order to avoid a hazard

FAILURE TO COMPLY RISKS PERSONAL INJURY, SHOCK HAZARD, FIRE, OR DAMAGE TO EQUIPMENT.

CAUTION

Personal injury hazard. The appliance is not suitable for unsupervised use by young children, aged, or infirm persons.

NOTICE

This equipment must be installed with adequate backflow protection to comply with applicable federal, state, and local codes.

Water pipe connections and fixtures directly connected to a potable water supply shall be sized, installed, and maintained in accordance with federal, state, and local codes.

OPERATING ENVIRONMENTAL TEMPERATURE: Do not store unit in temperatures of 32° F or below with tank filled with water. Make sure tank is drained and lines purged to avoid damage.

Specifications

Model	Description	Water	Electrical
TB3 Brewer with B1/3T Dispenser	Tea Brewer with Dispenser - 3 gallon capacity C-UL US, NSF Certification	1/4" water line required	120V / 1.8 kW / 15A / 1 Ph Line cord included, NEMA plug 5-15P
B1/3 Dispenser & Base	Dispenser - 3 gallon capacity NSF Certification	n/a	n/a
B1/3T Dispenser	Dispenser - 3 gallon capacity NSF Certification	n/a	n/a
SU3P Dispenser & Base	Dispenser - 3 gallon capacity NSF Certification	n/a	n/a

ICED TEA BREWER Model: TB3

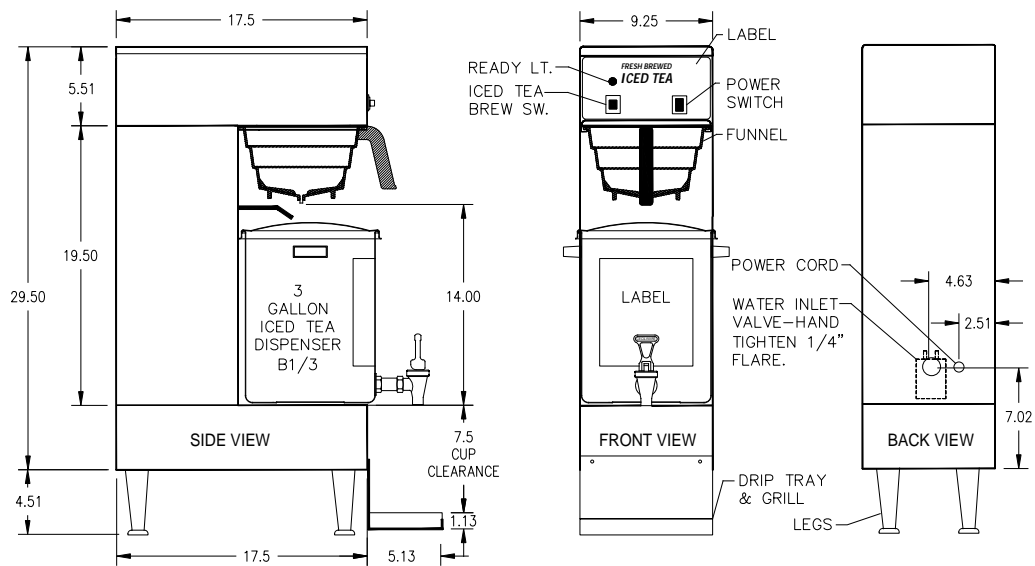

ICED TEA DISPENSERS

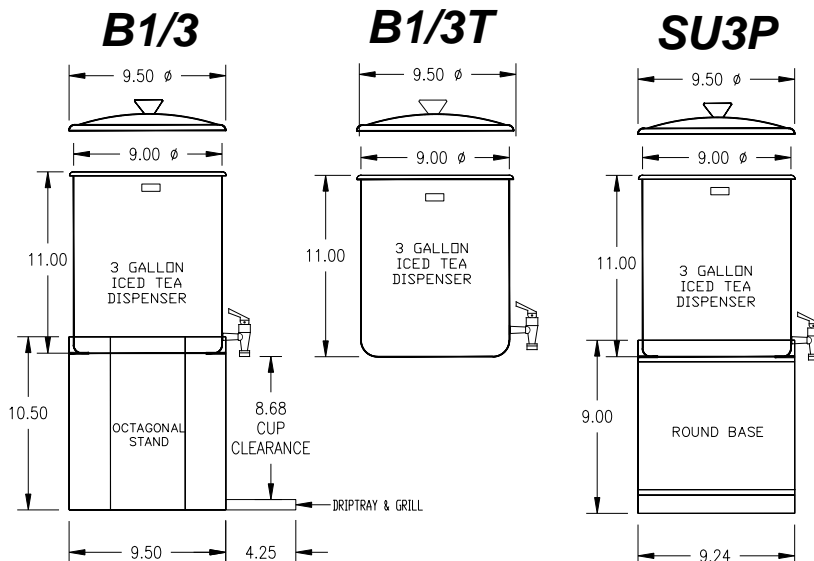

Installation

UNPACKING AND ASSEMBLY:

The machine is shipped with a set of (4) adjustable leveling feet already mounted, (1) brew funnel, (1) brew-thru cover, and (1) water inlet fitting and (1) Operator Manual.

1. Install unit on a level surface capable of supporting the weight of the brewer and filled dispenser.
2. Level brewer by adjusting feet height.

WATER INLET CONNECTION:

NOTICE: Installation to a water filter system is highly recommended to prevent lime and scale build up in the machine.

NOTICE: In areas with extremely hard water, a water softener must be installed in order to prevent a malfunctioning of the equipment and in order not to void the warranty.

NOTICE: Do not use a saddle valve to hook up the brewer since most of them restrict the water flow causing inconsistent brew batches.

This equipment must be installed to comply with the applicable federal, state, or local plumbing codes having jurisdiction.

In addition:

- A quick disconnect water connection or enough extra coiled tubing (at least 2x the depth of the unit) so that the machine can be moved for cleaning underneath.
- An approved back flow prevention device, such as a double check valve must be installed between the machine and the water supply.
- For use of machine outside the United States of America, connection to water supply mains should comply with local codes and regulations.

The brewer must be connected to a cold water supply with an operating pressure of 20psi minimum and 90psi maximum from a 1/2" supply line.

If pressure should exceed 90psi, install a pressure regulator to reduce the operating pressure to 50psi. Use 1/4" inch copper tubing for installation of less than 25 ft. and 3/8" copper tubing for more than 25 ft. from a 1/2" cold water supply line.

1. The tea brewer is equipped with a 1/4" flare water inlet fitting which is located in the back of the unit.
2. Install the water inlet fitting provided onto the inlet valve located in the back of the unit. Do not over-tighten.

3. Connect a 1/4" copper waterline to the 1/4" flare water inlet fitting of the valve.

INITIAL SET-UP:

1. Make sure unit is disconnected from power source.
2. Remove top cover and **make sure that heater switch is in the OFF position.** This will prevent heater damage due to lack of water in the tank.
3. Plug the brewer into a power source. Do not use extension cord.
4. Water will flow into the tank and will stop when the tank is fully primed (4-5 minutes).

Note: This process is automatic and is controlled by the Level Control Board and the Level Control Sensor, which is plugged into the top of the Tank.

5. Flip the Heater Toggle Switch to the ON position. This activates the heater. Allow 15-20 min. heat up time.
6. Unplug the brewer and replace the top cover.
7. Re-connect the brewer and test run the unit by going through a Brew Cycle.

Note: The machine is equipped with a Low Temperature Lockout system and will not brew until the hot water tank is filled with water and has reached the proper brew temperature of 197-203°F.

8. Insert the Brew Funnel and position empty Dispenser under it.
9. Go through one Brew cycle to make sure unit is operating properly.

Note: To test the brew cycle with cold water, flip Heater Switch to OFF position. This deactivates the temperature lockout and allows speedier testing.

Operation

Tea Brewing Procedure.

⚠ CAUTION: Operate with care. Tea Brewer dispenses HOT WATER and HOT TEA that can cause serious burns.

The Brewers are Factory pre-set to deliver the correct amount of hot water for best extraction of Hot Tea Concentrate and Cold Water Dilution. See **Flavor Chart.** Different tea blends might require some secondary adjustments of Hot and Cold water ratios in order to achieve their desired flavor profiles. This is easily accomplished by adjusting the Cold and Hot Brew Timers located inside the top. See instructions under **Adjustments** (for qualified Service Personnel only).

Operation (continued)

NOTICE: Clean and sanitize unit before first use. See following section, **Cleaning**.

Tea Brewing Instructions

1. Start each brew cycle with a clean brew funnel and a clean empty tea dispenser.
2. Place a tea bag into the funnel and slide the funnel into the funnel rails until it stops.
3. When the Green Brew Switch Light comes on, press and release the Brew Button.

NOTICE: This tea brewer will not brew until the pre-set brew temperature (197-203° F) is reached.

4. Allow approximately 3 minutes for the tea concentrate to stop dripping from the Funnel tip.
5. Carefully remove Brew Funnel and discard the used tea bag **ONLY AFTER** all visible dripping has stopped.

FLAVOR CHART

Type of Tea	Hot Water Brewing Concentrate	Cold Water Dilution	Tea Bag Size	Total Brew Time
Unsweet	0.75 gal. (96 oz) in 3 minutes	2.25 gal. (288 oz)	3 oz	6.0 min
Sweet	0.70 gal. (90 oz) in 3 minutes	2.00 gal. (256 oz)	3 oz	5.5 min.

Cleaning

⚠ CAUTION: Burn hazard. Water used for brewing tea is very hot. Use caution when brewing, pouring, or transporting hot tea. Never attempt to move the urn without first draining or allowing contents to cool.

NOTICE: Do not use scouring cleaners on the urn's surfaces. When cleaning stainless steel, only a ph neutral cleaner should be used. Use nylon or plastic brushes (not steel wire brushes) for removing food deposit.

Cleaning and Sanitizing Instructions

After Each Brew:

1. Dispose of grounds and rinse brew basket.
2. Rinse dispenser before reuse.

Daily: Clean and sanitize your tea brewer and dispenser at least **once every 24 hours**.

1. Remove and disassemble the faucet assembly by

unscrewing. Carefully inspect washers. Replace any damaged parts.

2. Place brew funnel, cover, drip tray cover, and faucet components into a warm soapy wash.
3. Clean all components by brushing or scrubbing. Use a bottle brush to wash faucet and faucet mounting location. Wash inside of dispenser.
4. Wipe exterior surfaces. Use only a soft cloth and warm soapy water or stainless steel polish on the outside to avoid scratches.
5. Rinse carefully to remove soap.
6. Prepare a sanitizing solution in accordance with local health department regulations. You may also refer to the US Food and Drug Administration regulation 21 CFR 178.1010 "Sanitizing Solutions" and US Environmental Protection Agency 40 CFR 18.940 "Tolerance exemptions for active and inert ingredients for use in antimicrobial formulations (Food-contact surface sanitizing solutions)".
7. Follow the instructions provided with the sanitizing agent.
8. Let all sanitized parts drain and dry naturally. **DO NOT WIPE THEM DRY.**
9. Reassemble brewer and dispenser.

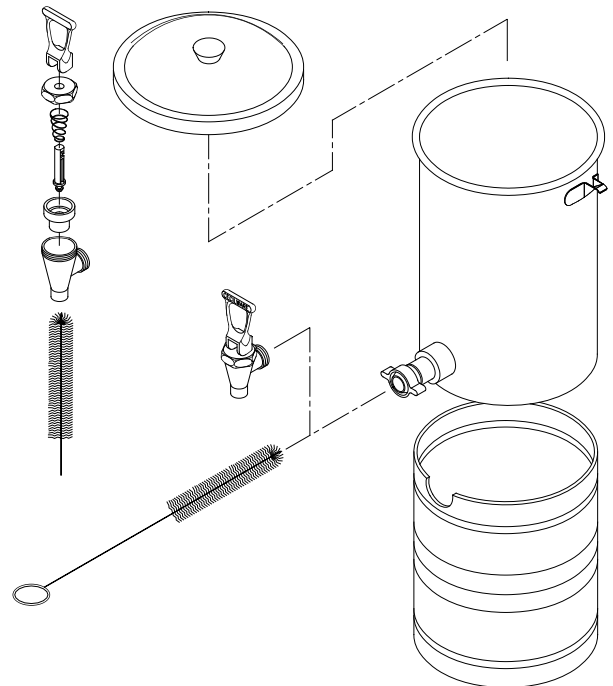

Maintenance

▲ WARNING: Brewer should be unplugged from electrical outlet before any service is performed.

ADJUSTMENTS TO BE PERFORMED BY QUALIFIED SERVICE PERSONNEL ONLY.

The water flow rate coming from the hot water tank is constant/fixed at 0.75 gal./min. Increasing or decreasing the amount of hot water dispensed from tank can be used to adjust the strength of the tea.

The Longer water flows - More water - Weaker tea; Less water flows - Less water - Stronger tea.

The TB3 Brewer will complete a full cycle in approximately 5 to 10 min.

BREW TIMER ADJUSTMENT (mounted inside top housing)

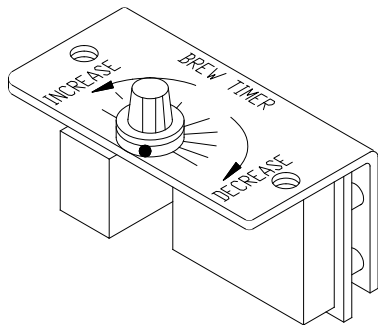

BREW TIMER
L264AL

Controls the brewing time (min.) for brewing Coffee and Hot Tea Concentrate.

The brewing time, temperature, and amount of product used in the funnel affects the drink strength. See **Flavor Chart** of Tea Flavors and Grams to be used.

Factory set at 3 min. for brewing 3 liters [3/4 gal.] of Tea Concentrate [later to be diluted with 2 1/4 gal. of cold water which makes up the total 3 gal. Iced Tea].

- To **increase or decrease dispensing time** and volume of hot water dispensed, turn knob in the direction shown on timer.

- To reset brewer to factory settings:

1. Push the Brew Button (HOT TEA), and then adjust Timer to 3 min.
2. Adjust the Dispense Valve 1/4 turn at a time, if necessary, to increase or decrease the Hot Water Flow.
3. Push the Brew Button (ICED TEA), and then adjust the Timer to 3 to 5 min. depending on the water pressure in the main water line.

COLD WATER DILUTION

DELAY TIMER ADJUSTMENT (located inside the unit, near the water inlet valve).

L595AL
DELAY TIMER

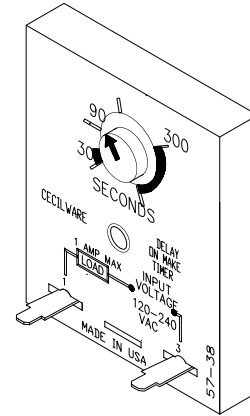

Set Delay Timer knob approximately as shown in diagram. This setting corresponds to a delay time of 1.5 minutes after the hot tea begins to dispense. If the water pressure requires a different setting on the Cold Water Timer, then the Delay Timer also needs to be adjusted so that it delays the Cold Water 1.5 minutes after the hot tea begins to dispense.

SPECIAL ORDER

This setting corresponds to a delay time of 5 minutes after the hot tea finishes dispensing.

If the water pressure is higher than 20 PSI, decrease the setting on the Cold Water Timer and Delay Timer.

If the water pressure is lower than 20 PSI, increase only the setting on the Cold Water Timer to Max.

▲ WARNING: Brewer should be unplugged from electrical outlet before any service is performed.

DUAL WATER INLET VALVE:

The Water Inlet Valve is located on the lower part of the main body with the threaded end protruding out of the back.

CD241L
WATER INLET
VALVE

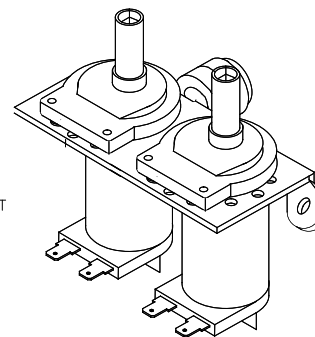

The Water Inlet Valve allows water flow up to 0.87 gal./min. [gpm].

One side supplies water to the tank and one side supplies water directly to the Iced Tea dilution water nozzle. The time that each side draws water is controlled by the Hot Water Timer and Cold Water Timer.

Maintenance (continued)

DISPENSE VALVE:

Locate Dispense Valve by removing the top lid of machine. Looking down into the machine, the Dispense Valve is mounted on the tank.

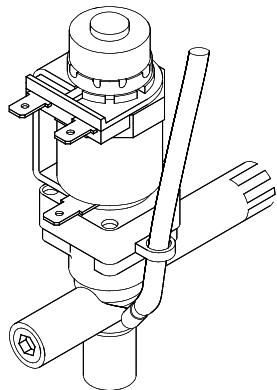

L467AL
DISPENSE VALVE

FIXED FLOW: 1 LITER/ MINUTE [0.26 gal./ minute]
TB3 3 liters in 3 minutes [0.78 gal. in 3 minutes]

THERMOSTAT ADJUSTMENT:

Locate Thermostat: Remove the top cover. Thermostat is mounted on top of tank.

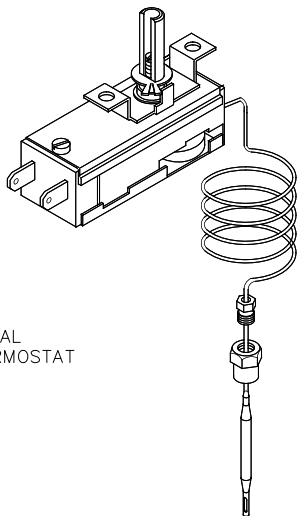

L681AL
THERMOSTAT

The thermostat is factory set to deliver hot brewing water at 195°F with the thermostat knob turned to full ON position. If adjustments should be necessary to increase or decrease the water temperature, proceed as follows:

To INCREASE the water temperature,

1. Turn Thermostat Shaft to its maximum clockwise, CW, position.
2. Remove the knob and locate the Slotted Adjustment Screw inside the hollow thermostat shaft.
3. Using a narrow-bladed screwdriver, engage slotted adjustment screw and turn it ¼ turn slowly counterclockwise, CCW.

4. Allow a few minutes for the temperature to reach set level. The Heater Light will go ON, indicating the heating element is activated, wait for it to go OFF, indicating that the water has reached new set temperature.
5. Take a temperature reading and repeat if necessary.
To DECREASE the water temperature - simply turn the Thermostat Knob one notch counterclockwise CCW to the next lower dial setting.

CRITICAL COMPONENTS TESTS

⚠ WARNING: Brewer should be unplugged from electrical outlet before any service is performed.

A) Water Inlet Valve Test

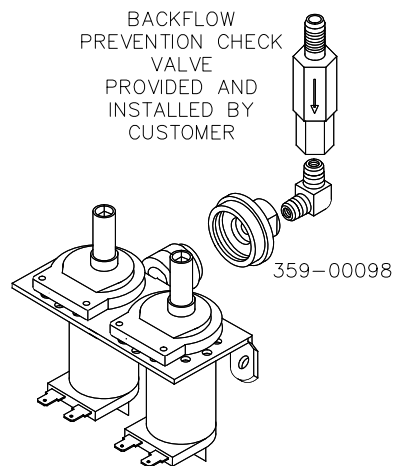

CD241L
WATER INLET
VALVE

Check hot water side, going to tank:

1. Turn power off. If the water level rises inside the tank, the Water Inlet Valve is leaking.
2. Disconnect wires from the Water Inlet Valve coil and connect a 2 wire line cord to the terminals. Plug it into electrical outlet. If water flows in and stops when you pull it out, the Valve is working correctly. Repeat this test a few times. The problem may be in the Probe or Water Level Control Board. If water does not flow in when the cord is plugged into an electrical outlet, the Solenoid coil may be damaged, opened, or the valve may have an obstruction preventing the water from flowing in. Clean or replace it.

Check cold water side, going to dilution nozzle:

1. Turn power off. If water keeps coming out of the dilution nozzle, the solenoid might be clogged or damaged.
2. Check Valve should be provided and installed by the customer to prevent backflow. To check proper function of Check Valve, disconnect water line from the Check Valve, check for dripping from the disconnected end of the Check Valve. If it leaks replace it.

Maintenance (continued)

⚠ WARNING: Brewer should be unplugged from electrical outlet before any service is performed.

CRITICAL COMPONENTS TESTS (CONTINUED)

B) Probe Test

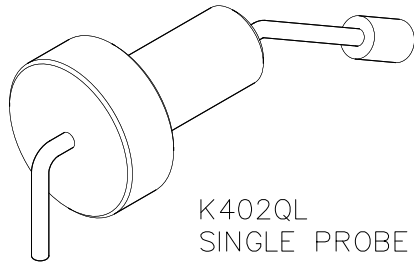

If lack of water persists, check the probe as follows:

1. Turn on the power and water supply. Check inside the tank to make sure the water is not touching the Probe.
2. Pull wire and terminal out of the Probe rod.
3. If water still does not flow after the wire is disconnected from the Probe, the problem may be in the Solid State Water Level Control Board.
4. If water starts flowing into the tank, the Probe may be grounded, due to excessive liming. Check with ohmmeter. Clean or replace probe.

C) Solid State Water Level Control Board Test

Check the board as follows:

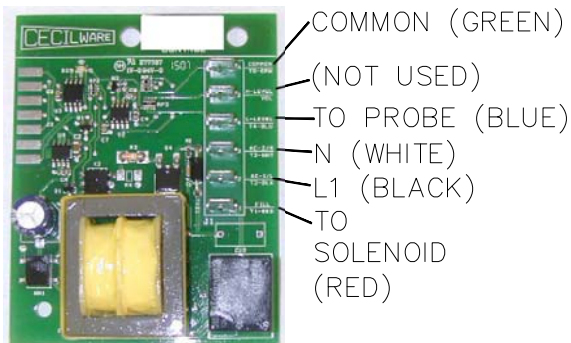

L690AL
DUAL PROBE LIQUID
LEVEL CONTROLLER

1. Make sure there is power input to the board at the terminals 2 & 3. Your voltmeter should read 115 Volts. It should read the same at terminals 1 & 3. This is the output power to electrify the coil of the Solenoid Valve to open it. The lack of voltage at terminals 2 & 4 will indicate that the board is not working properly.
2. Make sure all wire connections to the board are tight.

3. The grounding plate at the top, in the back of the board, should be securely grounded. The board will not work or will work erratically if it is not grounded properly.
4. If after this, the Controller is still failing to open the Water Inlet Valve, replace the Water Level Control Board.

Troubleshooting Guide

Before you call for help, please read the following:

⚠ WARNING To reduce risk of electrical shock, unplug the power cord before repairing or servicing any internal components. Before any attempt to replace a component, be sure to check all electrical connections for proper contact.

Problem	Possible Cause	Solution
Brewed Cold Tea.	Heater Switch OFF.	Turn Heater Switch ON.
	Run out of hot water.	Allow time for water in tank to heat after filling.
	Thermostat is OFF.	Set Thermostat at 197°F [to max. position].
	Loose electrical connection.	Check all electrical connections for contact.
	Thermostat is defective.	Replace Thermostat.
	Hi-Limit Temperature Switch is tripped.	Replace the Hi-limit Temperature Switch.
Tea too weak.	Bad Heating Element or Heater is burned out.	Replace Heater.
	Bad low temperature cutout circuit (Contactor/Relay).	Replace Contactor/ Relay.
	Not enough tea in the brew funnel. Water flow too low.	Put more tea in the brew funnel (see chart). Check flow rate. (It should be 0.26 gal /min.) Replace Dispense Valve.
Water keeps dripping or running from dilution nozzle.	Brew time is too short.	Adjust hot water timer to 3 min. 197°F (to max. position).
	Water is too cold.	Adjust Thermostat to 197°F (to max. position).
No water is going into tank at all or no water is coming from dilution nozzle.	Leaking Water Inlet Valve.	Clean/check fittings of Water Inlet Valve. Replace Water Inlet Valve if needed. See Water Inlet Valve Test .
	Clogged/ stuck Water Dispense Valve.	Clean/unclog Water Dispense Valve. Replace Dispense Valve if defective.
Water will not stop flowing into water tank.	Water Inlet Valve malfunction.	Check Water Inlet Valve. Replace if necessary. See Water Inlet Valve Test .
	Hi-Level Float Switch malfunction.	Test High-Level Float Switch. Replace if necessary.
	Probe malfunction.	Check Probe. Replace if necessary.
	Solid State Water Level Controls board malfunction.	Check The Water Level Controls. Replace if necessary.
Water is not heating up in the water tank.	Timer malfunction.	Check Timer: Compare time dispensing vs. set time on Timer. Replace if necessary.
	Water Level Probe malfunction.	Check Level Control Probe. Replace if necessary. See Probe Test .
	Solenoid (Water Inlet Valve) malfunction.	Check Solenoid. Replace if necessary.
Water is not heating up in the water tank.	Solid State Water Level Control board malfunction.	Check the Water Level Controls. Replace if necessary.
	Float Switch malfunction.	Replace Float Switch.
	Heater Switch is OFF.	Turn Heater Switch ON.
	Thermostat is OFF.	Turn Thermostat ON by turning Thermostat Knob clockwise.
	Loose connection on Thermostat.	Make sure all wires and ring terminals on the thermostat are tight.
Water is not heating up in the water tank.	Hi-Limit Temperature Switch is tripped or it is defective.	Reset the Hi-Limit Button. If heater still does not work, replace the Hi-limit Temperature Switch.
	Heater is burned out or defective.	Replace the Heater.
	Bad Low Temperature Cutout Circuit (Contactor/Relay).	Replace Contactor/ Relay.

Troubleshooting Guide (continued)

If you still need help, call Grindmaster-Cecilware Technical Service Department, (502) 425-4776 or (800) 695-4500 (USA & Canada only) (Monday through Friday 8 AM - 6 PM EST). Please have the model and serial number ready so that accurate information can be given.

Prior authorization must be obtained from Grindmaster-Cecilware for all warranty claims.

Grindmaster-Cecilware provides the industry's BEST warranty. Visit our website at GMCW.com for warranty terms and conditions.

Parts Diagram and List

Spare Parts

LARGE FUNNEL WITH STANDARD RIM USED ON TB3 PART NO V211AL

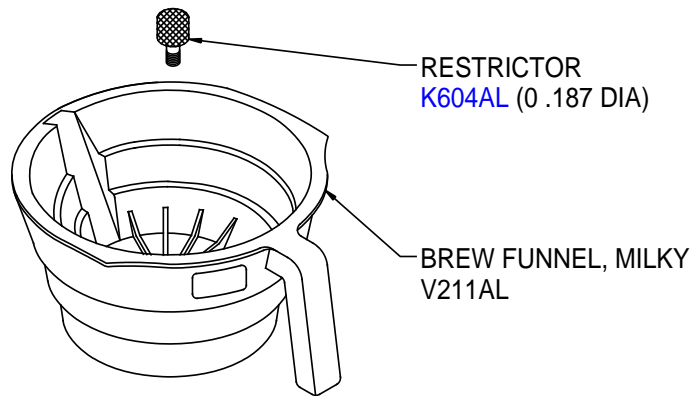

FAUCET BRUSH X159AL

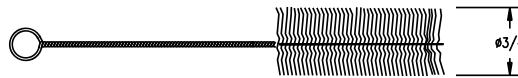

DRIP TRAY

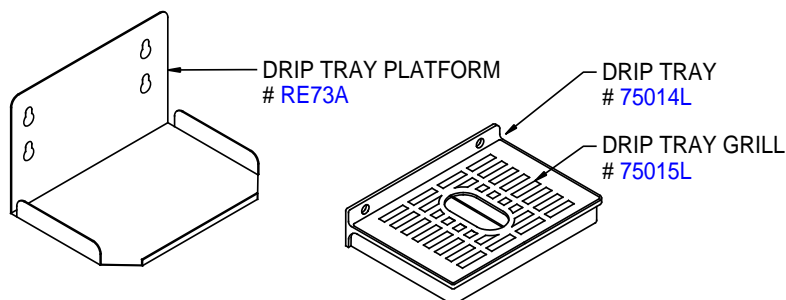

Parts Diagram and List (continued)

Spare Parts

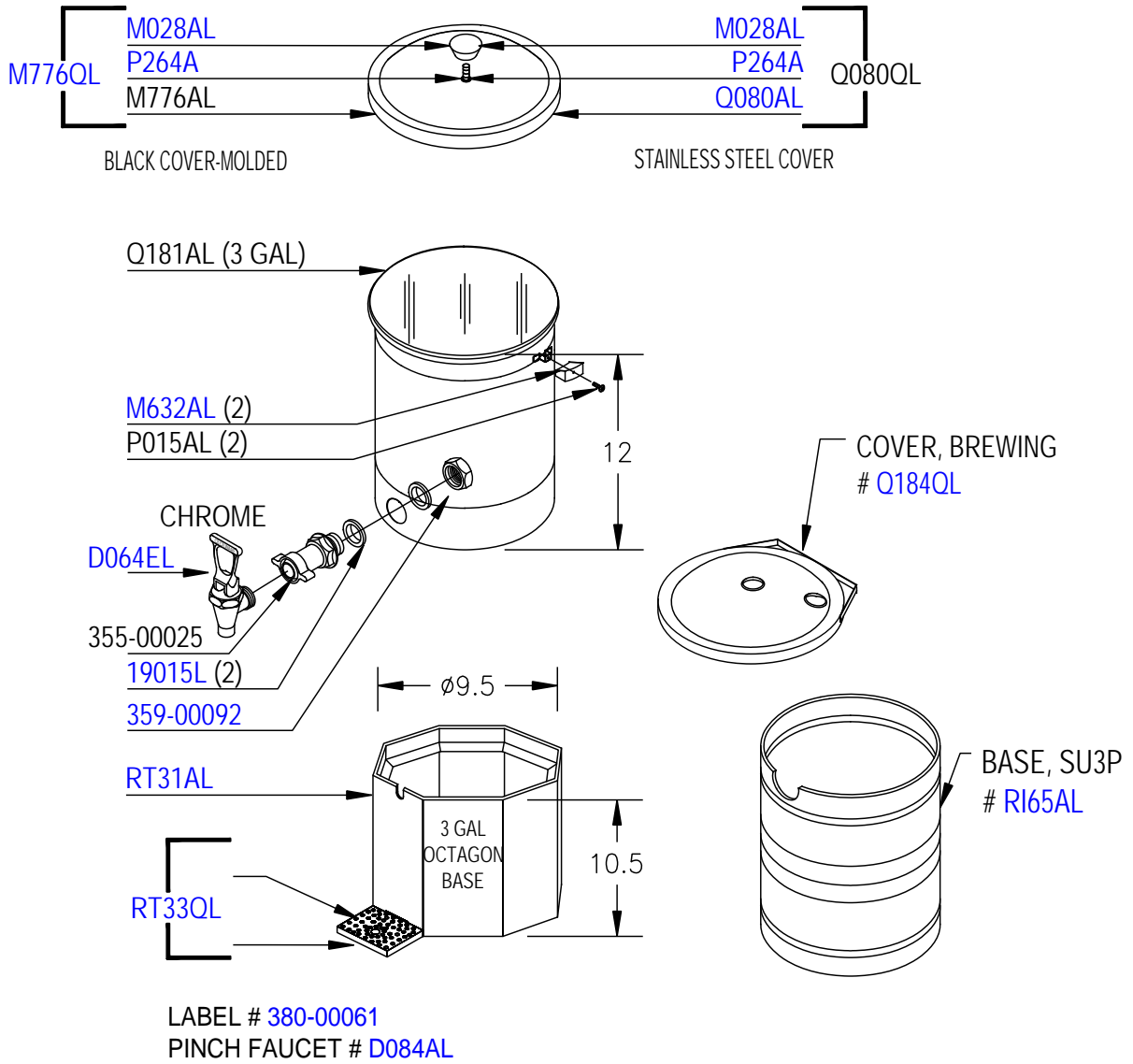

Parts Diagram and List (continued)

Brewer

TEA BREWER TB3

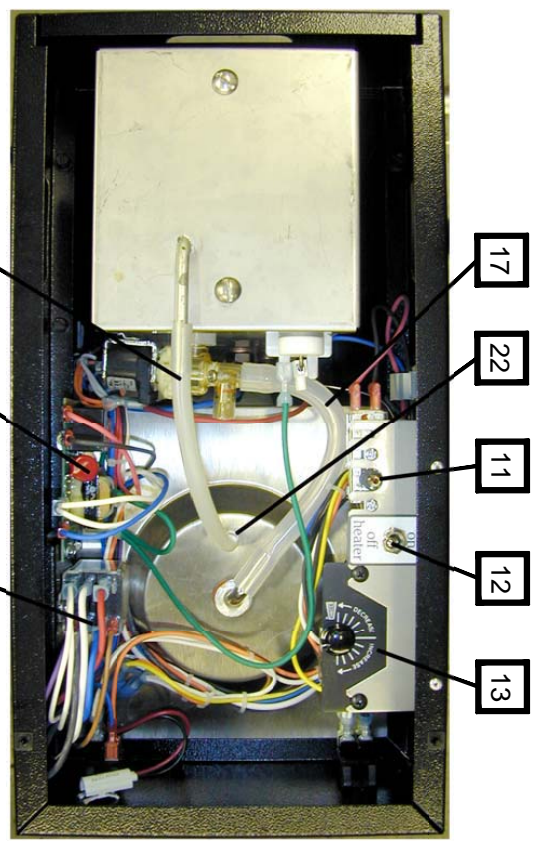
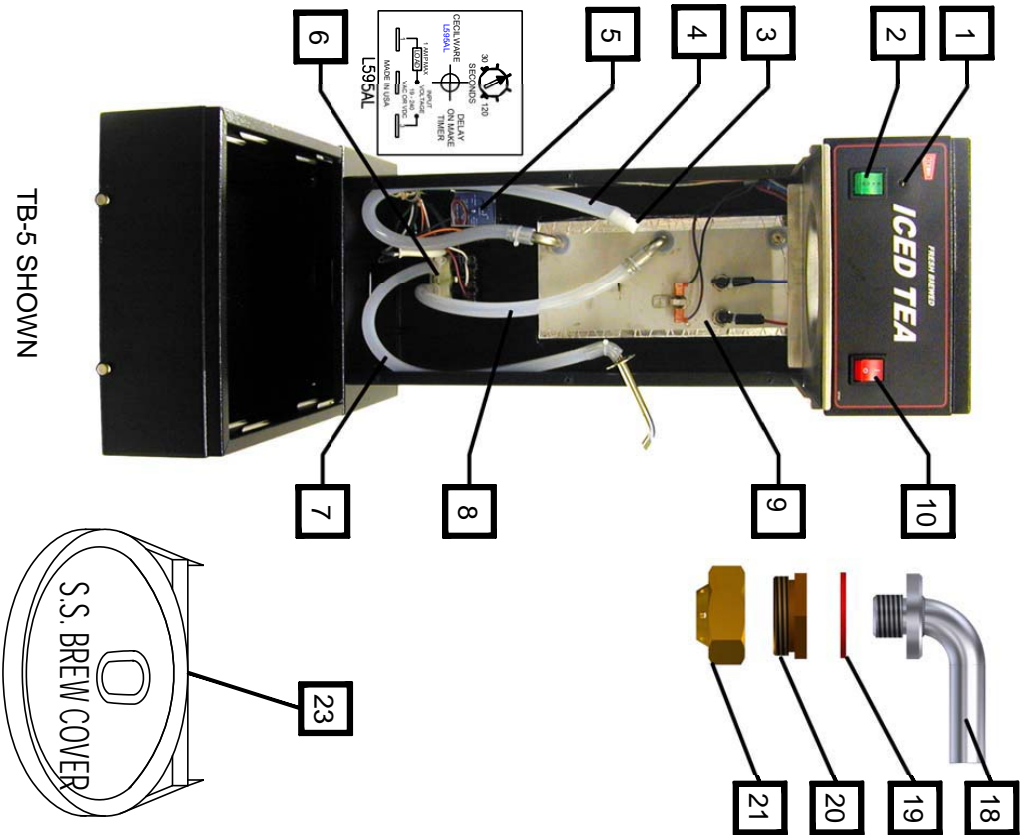

ITEM	DESCRIPTION	PART NO	QTY
1	INDICATOR LIGHT	32004L	1
2	BREW SWITCH	L291AL	1
3	DRAIN PLUG	M391AL	1
4	HOSE, DRAIN (24")	M326AL	1
5	DELAY TIMER	CD241L	1
6	WATER INLET VALVE	CD241L	1
7	HOSE, DILUTION (24")	M324AL	1
8	HOSE WATER INLET (24")	M326AL	1
9	HOT WATER TANK	RV33QL	1
10	POWER ON-OFF SWITCH	L155AL	1
11	THERMOSTAT	L681AL	1
12	HEATER SWITCH	L069AL	1
13	BREW TIMER	L264AL	1
14	DUAL LEVEL CONTROL BOARD	L690AL	1
15	RELAY TEMPERATURE LOCK-OUT	L539AL	1
16	OVERFLOW HOSE	M545AL	1
17	BREW HOSE	M326AL	1
18	SPRAY TUBE ASSEMBLY	K671QL	1
19	WASHER, RED SILICONE	MA16AL	1
20	SPRAY HEAD ADAPTER	K802AL	1
21	SPRAY HEAD	E101AL	1
22	FITTING, NOZZLE	K629AL	1
23	BREW-THRU COVER	Q184QL	1

Parts Diagram and List (continued)

HOT WATER TANK
Part No. RV33C 2.0 Gal

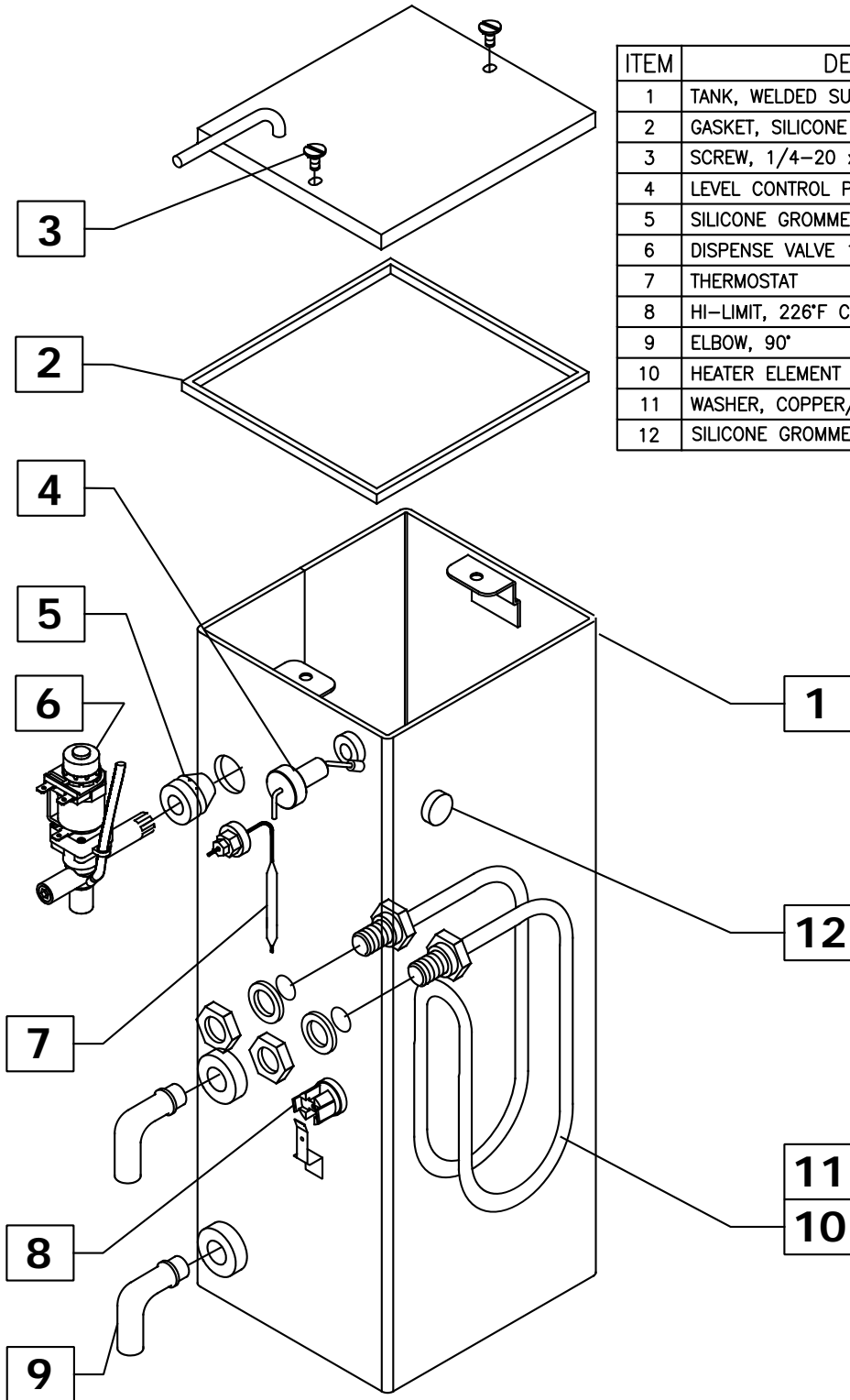

ITEM	DESCRIPTION	PART NO	QTY
1	TANK, WELDED SUB-ASSEMBLY	RV33QL	1
2	GASKET, SILICONE BUTT SPLCED	M600AL	1
3	SCREW, 1/4-20 x 5/8 SS		2
4	LEVEL CONTROL PROBE	K402BL	1
5	SILICONE GROMMET, 12mm	M461AL	5
6	DISPENSE VALVE 110V	L467AL	1
7	THERMOSTAT	L681AL	1
8	HI-LIMIT, 226°F CUTOUT	L573AL	1
9	ELBOW, 90°	K525AL	2
10	HEATER ELEMENT 120 V, 1750W	G382AL	1
11	WASHER, COPPER/ TEFLON	M730AL	2
12	SILICONE GROMMET, PLUG	M494AL	1

Wiring Diagram

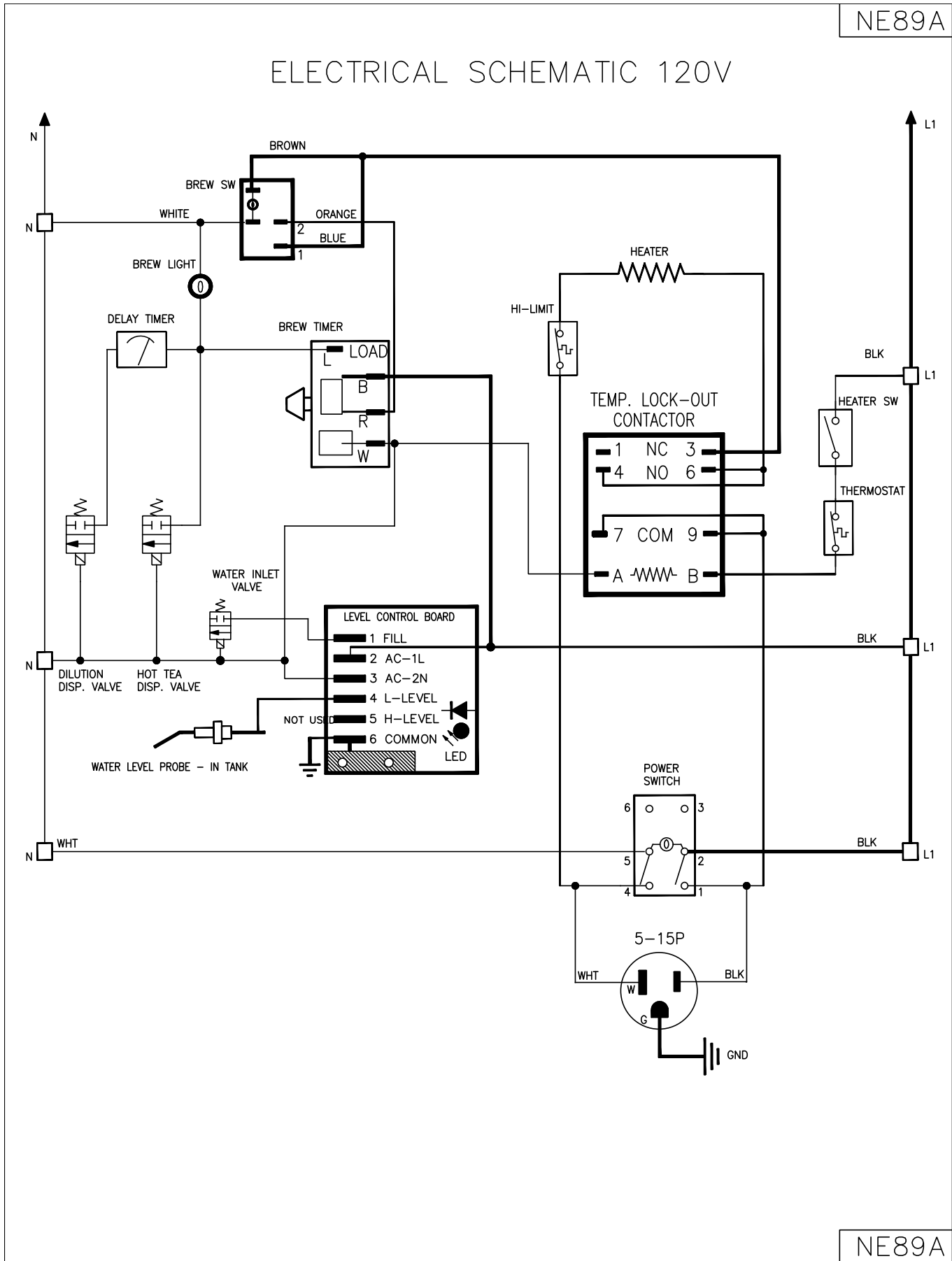

Grindmaster-Cecilware

4003 Collins Lane, Louisville, KY 40245 USA
Phone: 502.425.4776 Toll Free: 800.695.4500
Fax: 502.425.4664
Web: gmcw.com Email: info@gmcw.com

©2008 Grindmaster-Cecilware
Printed in USA



**Grindmaster
Cecilware**

0915 Form # CW-313-01
Part # 390-00046