

☆ IMPORTANT INFORMATION ☆ KEEP FOR OPERATOR ☆ IMPORTANT INFORMATION ☆

OPERATOR MANUAL

OM-CFPC

DOMESTIC
Part Number 121028

**MODEL: CFPC, CFPC/2
Braising Pans**

*Stainless Steel
Cabinet Mounted
Power Tilting
Electrically Heated*



**THIS MANUAL MUST BE RETAINED FOR FUTURE REFERENCE.
READ, UNDERSTAND AND FOLLOW THE INSTRUCTIONS AND
WARNINGS CONTAINED IN THIS MANUAL.**

WARNING
**DO NOT STORE OR USE GASOLINE OR OTHER FLAMMABLE VAPORS AND
LIQUIDS IN THE VICINITY OF THIS OR ANY OTHER APPLIANCE.**



IMPORTANT — READ FIRST — IMPORTANT

- CAUTION:** BE SURE ALL OPERATORS READ, UNDERSTAND AND FOLLOW THE OPERATING INSTRUCTIONS, CAUTIONS, AND SAFETY INSTRUCTIONS CONTAINED IN THIS MANUAL.
- WARNING:** THIS UNIT IS INTENDED FOR USE IN THE COMMERCIAL HEATING, COOKING AND HOLDING OF WATER AND FOOD PRODUCTS, PER THE INSTRUCTIONS CONTAINED IN THIS MANUAL. ANY OTHER USE COULD RESULT IN SERIOUS PERSONAL INJURY OR DAMAGE TO THE EQUIPMENT AND WILL VOID WARRANTY.
- CAUTION:** ELECTRICALLY GROUND THE PAN AT THE TERMINAL PROVIDED.
- WARNING:** THE BRAISING PAN MUST BE INSTALLED BY PERSONNEL WHO ARE QUALIFIED TO WORK WITH ELECTRICITY. IMPROPER INSTALLATION COULD RESULT IN PERSONAL INJURY OR EQUIPMENT DAMAGE.
- CAUTION:** STAND AWAY FROM THE HOT FOOD OR WATER WHILE TILTING THE PAN TO EMPTY IT.
- WARNING:** DO NOT HEAT AN EMPTY PAN FOR MORE THAN FIVE MINUTES AT A SETTING HIGHER THAN 300°F.
- WARNING:** AVOID ANY EXPOSURE TO THE STEAM ESCAPING FROM THE COVER VENT. DIRECT CONTACT COULD RESULT IN SEVERE BURNS
- WARNING:** AVOID ALL DIRECT CONTACT WITH HOT EQUIPMENT SURFACES. DIRECT SKIN CONTACT COULD RESULT IN SEVERE BURNS.
- WARNING:** AVOID ALL DIRECT CONTACT WITH HOT FOOD OR WATER IN THE BRAISING PAN. DIRECT CONTACT COULD RESULT IN SEVERE BURNS.
- WARNING:** IF THE PAN CONTAINS ITEMS IN SAUCE OR MELTED FAT, THEY COULD SLIDE FORWARD SUDDENLY DURING TILTING AND CAUSE THE HOT LIQUID TO SPLASH OUT.
- WARNING:** USE OF ANY REPLACEMENT PARTS OTHER THAN THOSE SUPPLIED BY GROEN OR ITS AUTHORIZED DISTRIBUTORS VOIDS ALL WARRANTIES AND MAY CAUSE BODILY INJURY AND/OR EQUIPMENT DAMAGE.
- NOTE:** SERVICE PERFORMED BY OTHER THAN FACTORY AUTHORIZED PERSONNEL WILL VOID ALL WARRANTIES.
- WARNING:** ALWAYS TURN OFF ELECTRIC POWER BEFORE WORKING ON INTERNAL COMPONENTS.
- WARNING:** BEFORE ANY CLEANING OPERATION, TURN THE THERMOSTAT TO “OFF” TO CUT OFF POWER TO THE HEATING ELEMENTS. BEFORE CLEANING ANY PART OTHER THAN THE INSIDE OF THE PAN, DISCONNECT THE ELECTRICAL SUPPLY AT THE CIRCUIT BREAKER OR FUSE BOX.
- WARNING:** AVOID CONTACT WITH CLEANERS IN ACCORDANCE WITH SUPPLIER AND MANUFACTURER RECOMMENDATIONS. MANY CLEANERS ARE HARMFUL TO THE SKIN, EYES, MUCOUS MEMBRANES AND CLOTHING. READ WARNINGS AND FOLLOW DIRECTIONS ON THE CLEANER LABEL.
- CAUTION:** NEVER LEAVE A CHLORINE SANITIZER IN CONTACT WITH STAINLESS STEEL FOR LONGER THAN 30 MINUTES. LONGER CONTACT CAN CAUSE CORROSION.
- WARNING:** DO NOT USE ANY FUSE WITH A HIGHER AMP RATING THAN THE RATING SPECIFIED FOR THAT CIRCUIT.

Table of Contents

IMPORTANT OPERATOR WARNINGS (READ FIRST) 2

EQUIPMENT DESCRIPTION 4

INSTALLATION 5

INITIAL START-UP 5

OPERATION 6

SEQUENCE OF OPERATION 7

CLEANING 8

MAINTENANCE 10

TROUBLESHOOTING 10

PARTS LISTS 12

DIAGRAMS & SCHEMATICS 16

REFERENCES 24

MAINTENANCE LOG 25

WARRANTY 26

OM-CFPC

Equipment Description

The Groen CFPC and CFPC/2 are stainless steel, electrically heated Braising Pans. They are equipped with integrated heating elements, a power tilting mechanism, electrical controls and a hinged cover. The Braising Pan serves as a braising unit, griddle, fry pan, oven, kettle, *bain-marie*, or food warmer and server. It can also be adapted for use as a non-pressure steamer.

Construction of the pan body employs heavy-duty stainless steel welded into a solid piece. It has a polished interior and exterior finish. A pouring lip is welded to the top of the front wall. The cooking surface is a stainless steel clad plate fitted with clamped-on electrical heating elements. The elements are positioned to ensure uniform heat transfer over the cooking surface.

The pan is mounted on a double-door cabinet with friction latches. The cabinet exterior is polished to a **m** Four finish, and accented on the front with a color strip. A removable pan support is provided as standard equipment.

An electrically powered mechanism tilts the pan forward. A three position switch on the front of the control console gives the operator positive, smooth-acting control of pan body tilt.

Heating elements and other electrical components are enclosed for safety. The

thermostat, heating indicator light, and tilting switch are contained in a compact control console which is mounted beside the pan body.

The thermostat provides automatic control of cooking temperature. Turning the thermostat dial starts and stops heating and sets the pan temperature. Installation requires two electrical connections: 115 Volt service for the tilting actuator, and higher voltage for the heating elements..

A vented, heavy gauge, one-piece, stainless steel cover with a rear condensate drip shield on the underside is standard. A fully enclosed spring-type actuator counter balances the cover to maintain either the opened or closed position. The cover opens to the back. It is hinged to the frame, moving independently of the pan body.

CFPC/2 models are distinguished from CFPC models by having the control console on the pan's right rather than left, a cabinet frame which is constructed entirely of stainless steel, by slightly different dimensions, and a hand crank override on the tilting mechanism.

The following models and options are available:

Optional Equipment (Either Model)

1. Fill faucet with swing spout
2. Model REJ Steamer Insert
3. Pouring Lip Strainer

PAN DIMENSIONS

Model	Left-to-Right		Front-to-Back		Depth	
CFPC-3	31 inches	787 mm	24 inches	610 mm	7 - 9 in.	178 - 229 mm
CFPC-4	41 inches	1041 mm	24 inches	610 mm	7 - 9 in.	178 - 229 mm
CFPC/2-3	30¾ inches	781 mm	25 inches	635 mm	7 - 9 in.	178 - 229 mm
CFPC/2-4	41 inches	1051 mm	25 inches	635 mm	7 - 9 in.	178 - 229 mm

ELECTRICAL SPECIFICATIONS - ALL FOR 60 Hz

Models	CFPC-3 or CFPC/2-3	CFPC-4 or CFPC/2-4
208 Volt One Phase Three Phase	11.5 KW 55 AMP 32AMP	14.5 KW 69 AMP 40 AMP
240 Volt One Phase Three Phase	12 KW 50 AMP 31AMP	15 KW 63 AMP 38 AMP
480 Volt Three Phase	12 KW 15 AMP	15 KW 18 AMP

Tilting Motor for all models is 120 Volts, one phase, 6 AMP

Inspection and Unpacking

The unit will arrive completely assembled, wrapped in protective plastic on a heavy skid, in a heavy cardboard carton. Immediately upon receipt, inspect the carton for damage. Report any apparent shipping damage or an incorrect shipment to the delivery agent.

When installation is to begin, get someone to assist in removing the carton. Lift it straight up and away from the unit. **Do not simply raise it and push backwards - you will break the cover assembly vent handle.** Write down the model number, serial number, and installation date of your unit, and keep this information for future reference. Space for these entries is provided at the top of the Service Log in this manual.

Cut the straps holding the unit on the skid, and lift the unit straight up off the skid.

CAUTION

SHIPPING STRAPS ARE UNDER TENSION AND CAN SNAP BACK WHEN CUT.

UNIT WEIGHS 545 TO 685 LB. (248 TO 310 KG). FOR SAFE HANDLING, INSTALLER SHOULD OBTAIN HELP AS NEEDED, OR EMPLOY APPROPRIATE MATERIALS HANDLING EQUIPMENT (SUCH AS A FORKLIFT, DOLLY, OR PALLET JACKET) TO REMOVE THE UNIT FROM THE SKID AND MOVE IT TO THE PLACE OF INSTALLATION.



Installation

WARNING

THE BRAISING PAN MUST BE INSTALLED BY PERSONNEL WHO ARE QUALIFIED TO WORK WITH ELECTRICITY. IMPROPER INSTALLATION COULD RESULT IN PERSONAL INJURY OR EQUIPMENT DAMAGE.

Internal wiring for the Braising Pan is supplied complete. When you receive it, the unit is ready for connection. A wiring diagram is inside the control box, as well as in this manual (Pages 14-21). Your pan was operated and tested at the factory to confirm that all controls and heating elements were functioning correctly.

Installation is as follows:

1. Set the unit in place and level it by turning the adjustable feet. Make sure the pan body is at its lowest position and check levelness by placing a spirit level on the bottom of the pan. The unit must be level to avoid uneven cooking across the pan.
2. Bolt the rear legs to the floor.
3. At the electrical service entrance in the bottom of the control box, make a

waterproof connection with the incoming power line. A BX connection is not recommended.

CAUTION

ELECTRICALLY GROUND THE PAN AT THE TERMINAL PROVIDED.

4. Provide the proper electrical supply as specified on the electrical plate attached to the equipment. Observe local codes and/or the National Electrical Code in accordance with ANSI/NFPA 70 — latest edition.
5. Any mechanical or electrical change must be approved by the Groen Food Service Engineering Department.

Initial Start-Up

Now that the Braising Pan has been installed, you should test it to ensure that it is operating correctly.

1. Remove all literature and packing materials from the interior and exterior of the unit.
2. Turn on the electrical power to the unit.
3. Put enough water into the pan to cover its bottom to a depth of $\frac{1}{4}$ " to $\frac{1}{2}$ ". With the tilt mechanism still lowered all the way back to the horizontal position, note how the water covers the pan bottom. This is a good method to confirm that the unit is properly leveled.
4. Set the thermostat to 235°F. The heating indicator light should come on to indicate that the pan is heating. Heating should continue until the water boils.

5. To shut the unit down, turn the thermostat dial to "OFF."

CAUTION

STAND AWAY FROM THE HOT WATER WHILE TILTING THE PAN TO EMPTY IT.

6. Position a container for the pour-off and press down on the power tilt switch so that the water pours out. This will confirm that the pan body can be tilted from horizontal to vertical. Pull the switch up to lower the pan.

If the unit functions as described above, it is ready for use. If it does not, call your local Groen Authorized Service Agent.

Operation

Operator Controls on the Braising Pan are the thermostat dial and power tilt switch, both located on the front of the unit. The dial turns electric power for the pan on or off, and sets the pan's operating temperature. The power tilt switch is used to raise or lower the pan body. Press the switch **down to raise** the pan or **up to lower** it.

A. Start-up Procedure

1. Set the thermostat dial to the desired temperature between 100 and 400°F. The glowing Heat Indicator Light shows that the pan is heating. When the light cycles on and off, it indicates that the pan is being held at the set temperature. Once in each of these cycles you may hear the contactors in the control box make a clicking sound. This is normal.
2. For best results when braising or frying, preheat the pan before putting in any food. For an even temperature across the pan, preheat at a setting of **300°F or less** for 15 minutes, or through several on/off cycles of the thermostat.



WARNING
DO NOT HEAT AN EMPTY PAN FOR MORE THAN FIVE MINUTES AT SETTINGS ABOVE 300°F. DAMAGE TO THE PAN COULD RESULT.

AVOID CONTACT WITH PAN SURFACES. SEVERE BURNS CAN RESULT.

B. Cooking

1. To simmer or slowly heat an item, set the dial at about 210°F or lower. Put the cover down to keep moisture loss at a minimum, or leave it up to help dry the product. Set the thermostat higher to cook or drive moisture off faster. The thermostat may be adjusted to any setting in its range to cook exactly as you wish.
2. Leave the cover vent open to allow excess steam to escape. For longer simmering, you may wish to close the vent.



WARNING
AVOID ANY EXPOSURE TO THE STEAM ESCAPING FROM THE COVER VENT. DIRECT CONTACT COULD RESULT IN SEVERE BURNS

3. To check cooking progress when the cover has been closed, grasp the plastic handle of vent cover and lift it slightly while moving it quickly to either side. Standing at one side of the pan to avoid the steam that will be released, grasp the nearest corner of the cover handle and raise the cover. The cover will stay in the open position until you put it down.



WARNING
AVOID ALL DIRECT CONTACT WITH HOT EQUIPMENT SURFACES. DIRECT SKIN CONTACT COULD RESULT IN SEVERE BURNS.

AVOID ALL DIRECT CONTACT WITH HOT FOOD OR WATER IN THE BRAISING PAN. DIRECT CONTACT COULD RESULT IN SEVERE BURNS.

IF THE PAN CONTAINS ITEMS IN SAUCE OR MELTED FAT, THEY COULD SLIDE FORWARD SUDDENLY DURING TILTING AND CAUSE THE HOT LIQUID TO SPLASH OUT.

C. To Tilt Pan

1. First, **raise the cover.**
2. Push the power tilt switch down to raise the pan, or up to lower it. The spring-loaded switch will return to the OFF (middle) position when released.
3. Model CFPC/2 only:

If the power tilt mechanism stops working and the actions recommended in the

OM-CFPC

Trouble Shooting Section of this manual do not correct the problem, you can tilt the body manually.

- a. Fit the provided hand crank onto the slotted shaft end that protrudes from the actuator motor (the end facing the front of the unit).
- b. Turn the crank clockwise to lower the pan or counterclockwise to raise the pan.
- c. Manual cranking will take several minutes, but the operation can be speeded up by using a reversible electric drill with a screwdriver bit in place of the hand crank.

D. To Shut Down Pan

Turn the thermostat to "OFF" to stop heating element operation. For prolonged shutdown, or before maintenance or cleaning, also cut off power to the unit at the main circuit breaker or fuse panel.

E. Daily Cleaning

After each use, turn the thermostat to "OFF" and clean all food contact surfaces to ensure proper sanitation. At the end of the day, or at least once every 24 hours, turn off the heat and shut off electric power to the unit and clean both the interior and exterior of the pan. **See Page 9 for detailed cleaning instructions.**

Sequence of Operation

The following "action-reaction" outline is provided to help you understand how the braising pan actually functions.

When you start up the pan by turning the thermostat from "OFF" to a desired temperature, the thermostat switch closes. This causes the contactors to close, and allows power to flow to the heating elements and the indicator light.

When the pan temperature reaches the value set on the thermostat dial, the thermostat switch opens and causes the contactors to open. This stops the flow of power to the heating elements and the indicator light.

As soon as the thermostat senses that the pan is cooling below the set temperature, the thermostat closes, the contactors close, and the heaters and indicator light come on again.

This on and off cycle continues, maintaining the pan at the set temperature. This is why the indicator light on and off cycling is seen during normal operation.

If the pan temperature exceeds 425°F for any reason, a high-limit thermostat shuts off the power until the pan cools. At that point, the thermostat automatically resets to permit normal operation to start again.

Turning the thermostat to "OFF" shuts down all control and heating circuits.

The thermostat controls heating by alternating between feeding full power and completely cutting power off. The pan heats as fast as it

can until it reaches the set temperature, no matter what that temperature is. Turning the thermostat to a higher setting will cause heating to continue *longer*, until the pan reaches a higher temperature, but it cannot make the pan heat any *faster*.

The power tilt switch controls a reversible motor that drives a ball screw mechanism. When the switch is held in the lowered position, the mechanism raises the pan body. The body rests on a trunnion near the front corners, so it tilts forward until the switch is released or the body reaches its vertical limit.

If the tilting motor gets too hot during operation, an overheat protection switch will open and stop the motor. When the motor has cooled sufficiently, the switch will automatically reset and permit tilting to begin again.

Cleaning

1. Suggested Tools

- a. Cleaner, such as Klenzade HC-10
- b. Brushes in good condition
- c. Cloth for cleaning controls
- d. Chlorine sanitizer such as Klenzade XY-12
- e. Heavy Duty Cleaner, such as Klenzade LC-30

2. Procedure



WARNING
BEFORE ANY CLEANING OPERATION, TURN THERMOSTAT DIAL TO "OFF" TO CUT ANY POWER TO THE HEATING ELEMENTS. BEFORE CLEANING ANY PART OTHER THAN THE INSIDE OF THE PAN, DISCONNECT ELECTRICAL SUPPLY AT CIRCUIT BREAKER OR FUSE BOX.

- a. Clean all food-contact surfaces soon after use. It is best to clean the pan before it has completely cooled. If the unit is in continuous use, completely clean and sanitize both the inside and outside at least once every 12 hours.

CAUTION
KEEP WATER AND SOLUTIONS OUT OF CONTROLS AND ELECTRICAL EQUIPMENT. DO NOT SPRAY OR HOSE THE CONTROL BOX OR OTHER ELECTRICAL CONNECTIONS. THEY ARE NOT WATER-PROOF.

- b. To remove any large amount of food left in the pan, tilt the pan all the way up and flush it with lukewarm water. Do not damage the surface of the pan by scraping it with a metal tool.
- c. Following the supplier's directions, make up a warm solution of the cleaner. Carefully wash the inside and outside of the pan body with the cleaning solution.



Use a sponge, cloth or plastic brush to clean the pan.



Scrapers or steel wool can harm the pan surface.



CAUTION
MOST CLEANERS ARE HARMFUL TO THE SKIN, EYES, MUCOUS MEMBRANES, AND CLOTHING. PRECAUTIONS SHOULD BE TAKEN. WEAR RUBBER GLOVES, GOGGLES OR FACE SHIELD AND PROTECTIVE CLOTHING. READ THE WARNINGS AND CAREFULLY FOLLOW THE DIRECTIONS ON THE CLEANER LABEL.

- d. Use a cloth moistened with cleaning solution to clean controls, the control console, and electric conduit.
- e. Rinse the pan very well with lukewarm water, and drain it completely.

OM-CFPC

- f. As part of the daily cleaning program, clean all inside and outside surfaces that may have been soiled. Remember to check such parts as the undersides of the cover, the electrical console and other more remote spots. Clean between the pan body and the control console using the brush provided (P/N 058705).
- g. To remove materials stuck to the equipment, use a brush, sponge, cloth, plastic or rubber scraper, or plastic wool with the cleaning solution. To make washing easier, let the cleaning solution sit in the unit and soak into the residue, or heat the solution briefly. Do **not** use any gritty cleaner or metal tool that might scratch the surface. Scratches make the surface harder to clean, and also provide places for bacteria to grow. Do **not** use steel wool. Small bit of steel wool left in the surface of the unit can cause rusting and pitting.
- h. The outside of the unit may be polished with a recognized stainless steel cleaner such as Zepper from the Zep Manufacturing Company.
- i. When the equipment needs to be sanitized, use a sanitizing solution equivalent to one that supplies 100 parts per million available chlorine. Get advice about the best sanitizing agent from your supplier of sanitizing products.
- j. Following supplier instructions, apply the sanitizing agent after the unit has been cleaned and drained. Thoroughly drain off the sanitizer.
- k. After the unit has been cleaned, sanitized and drained, let all surfaces air dry unless the unit must be used again right away.
- l. It is recommended that the unit be sanitized just before use. Follow the directions of the sanitizer supplier.
- m. About once a week (more often if the water is very hard), use a heavy duty cleaner to remove any mineral deposits or film left by hard water or foods. Follow the supplier's directions very carefully, and rinse the unit off thoroughly as soon as cleaning is finished.
- n. If especially difficult cleaning problems persist, contact your cleaning product supplier for help. The supplier has a trained technical staff with laboratory facilities to serve you.

CAUTION
NEVER LEAVE A CHLORINE SANITIZER IN CONTACT WITH STAINLESS STEEL SURFACES FOR LONGER THAN 30 MINUTES. LONGER CONTACT CAN CAUSE CORROSION.

Maintenance

WARNING
USE OF REPLACEMENT PARTS OTHER THAN THOSE SUPPLIED BY GROEN OR THEIR AUTHORIZED DISTRIBUTORS CAN CAUSE INJURY TO THE OPERATOR AND DAMAGE TO THE EQUIPMENT AND WILL VOID ALL WARRANTIES. SERVICE PERFORMED BY OTHER THAN FACTORY-AUTHORIZED PERSONNEL WILL VOID ALL WARRANTIES.

Your Braising Pan is designed to require minimum maintenance, but certain parts may require replacement after prolonged use. After installation, no user adjustment should be necessary. If a service need arises, only authorized personnel should perform the work.



WARNING
ELECTRICAL POWER MUST BE SHUT OFF BEFORE ANY WORK IS PERFORMED ON INTERNAL COMPONENTS.

Service personnel should check the unit at least once a year. This should include inspecting electrical wires and connections and cleaning inside of the control console. A Maintenance and Service Log is provided at the rear of this manual. Each time work is performed, enter the date on which it was done, what was done, and who did it.

Troubleshooting

Your Groen Braising Pan will operate smoothly and efficiently if properly maintained. However, the following is a list of checks to make in the event of a problem. If the actions suggested do not solve the problem, call your qualified Groen Service Representative. For the phone number of the nearest agency, call your area Groen representative or the Groen Parts and Service Department. If an item on the list is followed by **Y**, the work should only be performed by a qualified service representative.

WARNING

USE OF ANY REPLACEMENT PARTS OTHER THAN THOSE SUPPLIED BY GROEN OR THEIR AUTHORIZED DISTRIBUTORS CAN CAUSE INJURY TO THE OPERATOR AND DAMAGE TO THE EQUIPMENT AND WILL VOID ALL WARRANTIES.

SERVICE PERFORMED BY OTHER THAN FACTORY-AUTHORIZED PERSONNEL WILL VOID ALL WARRANTIES.

SYMPTOM	WHO	WHAT TO CHECK <small>Y indicates items which must be performed by an authorized technician.</small>
Pan will not heat, but indicator light comes on.	Auth Service Rep Only	a. Heating elements for short circuit. Y
Pan will not heat, and indicator light will not light	User	a. That power supply is on. b. Fuses, accessible by removing caps on the side of the control box. REPLACE A BLOWN FUSE ONLY WITH A FUSE OF THE SAME AMP RATING.
	Auth Service Rep Only	c. For loose or broken wire. Y d. Thermostat functioning, by listening for a click when the switch opens or closes. Y e. Contactor functioning. Y
Pan continues to heat after it reaches desired temperature	User	a. Thermostat dial setting.
	Auth Service Rep Only	b. Thermostat functioning, by listening for a click when the switch opens or closes. Y c. Thermostat calibration. Y d. Contactor, to determine if it is de-energized. Y
Pan does not reach desired temperature.	User	a. Thermostat dial setting.
	Auth Service Rep Only	b. Heating elements for ground short or open (burned out) element. Y c. Thermostat functioning, by listening for a click when the switch opens or closes. Y d. Thermostat calibration. Y e. Contactor functioning. Y
Rapid clicking noise (chattering)	Auth Service Rep Only	a. For low voltage. Y b. Contactor for dirt or corrosion on the contacts. Y
Uneven cooking due to "hot spots."	User	a. That the pan body is level
Uneven cooking due to "cold spots."	Auth Service Rep Only	a. For open (burned out) heating element. Y
Pan will not tilt	User	a. That electrical power supply is on. b. For overheated actuator motor. Wait 15 minutes or less for motor to cool, then operate the power tilt. (For instructions on manual operation see Page 7.
	Auth Service Rep Only	c. For burned out capacitor or motor. Y

OM-CFPC

Parts List Model CFPC

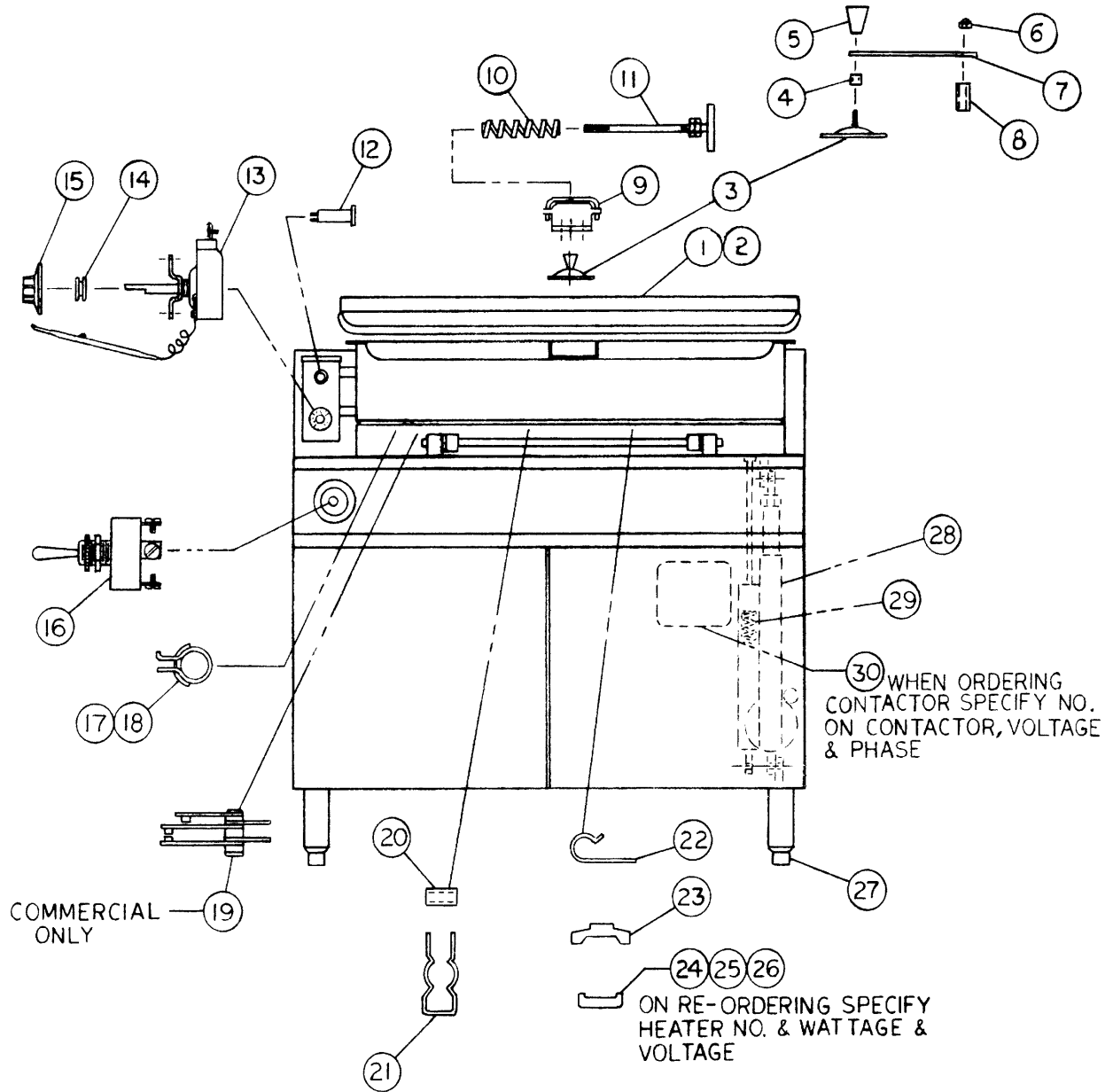

**Parts List
Model CFPC**

Key	Description	Part No.	Key	Description	Part No.
1	Cover Assembly FPC-3	014031	18	Clamp, Hose for One Phase	009966
2	Cover Assembly FPC-4	014032	19	Thermostat, High Limit	012840
3	Cover, Vent	003265	20	Bushing, Porcelain	012606
4	Spacer, Short Vent	002378	21	Hanger, Minerallac	012852
5	Knob, Plastic	002408	22	Clamp	009968
6	Nut, Dome	005471	23	Clamp, Strip Heater	012844
7	Arm for Vent Cover	002377	24	Heater, Strip, 950W for 208V	012842
8	Spacer, Long Rear	012733	25	Heater, Strip, 1000W for 240-380V	012843
9	Actuator, Cover, Model 51	014085	26	Heater, Strip, 1000W for 480V	012908
10	Spring, High Pressure	012533	27	Foot, Bullet	013275
11	Rod Assembly, Spring	012524	28	Actuator, Tilting, for CFPC-3	002655
12	Indicator Light Assembly	016028		Actuator, Vertical Tilting, for CFPC-4	N/A
13	Thermostat, Adjustable	012838		Actuator Horizontal Tilt for CFPC-4	N/A
14	Grommet, Rubber	001518	29	Spring, booster for 9" deep CFPC-4	003267
15	Knob, Thermostat	003908	30	Contactator (See Note)	
16	Switch, Momentary Toggle	002664	31	Transformer (Not Shown)	012827
17	Clamp, Hose, for Three Phase	009967			

OM-CFPC

Parts List Model CFPC/2

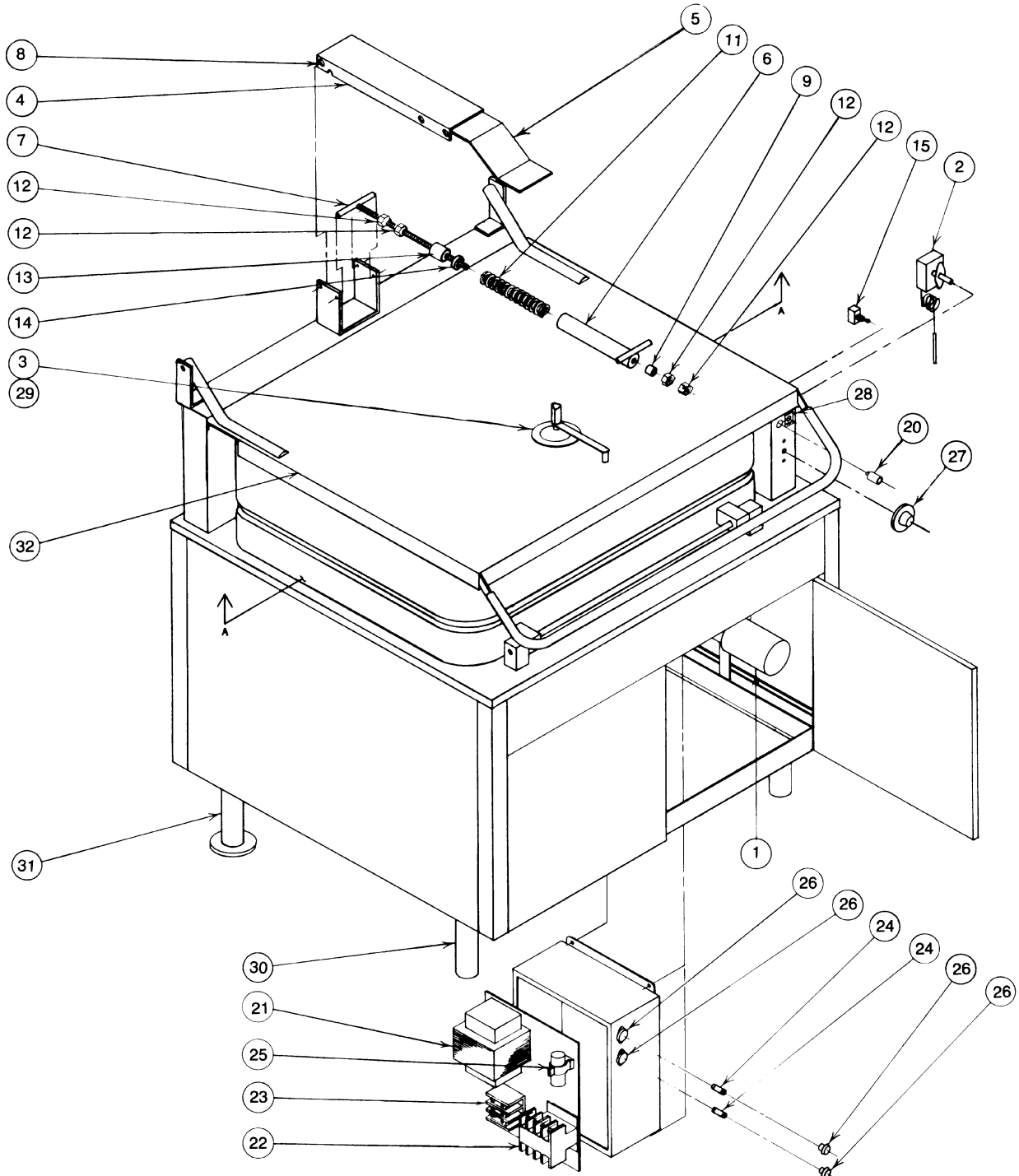

CONTROL BOX IS LOCATED ON RIGHT
WALL INSIDE THE MAIN CABINET.

**Parts List
Model CFPC/2**

Key	Description	Part No.	Key	Description	Part No.
1	Actuator, Tilting	045880	18	Tube, Sealtite ¾ O.D. ½ I.D.	012606
2	Thermostat, Adjustable	012838	19	Hanger, Conduit	012852
3	Vent Assembly, Cover	050359	20	Indicator Lamp, 115 Volt Red	002986
4	Body, Actuator	002440	21	Transformer, 208, 240 and 480 Volt	051469
5	Bracket, Cover	013277		Transformer, 380 Volt	054762
6	Housing Assembly, Spring	012407	22	Contact, 208, 240 and 480 Volt	006950
7	Pin Assembly, Rod	012524		Contact, 380 Volt	054761
8	Pin, Actuator Hinge	012525	23	Block, Terminal	002577
9	Spacer, Front	012528	24	Fuse, SC6, 6 AMP	003982
10	Ring, External Retaining (not shown)	012529	25	Capacitor 18 : F	050384
11	Spring, High Pressure	012533	26	Fuse holder	002944
12	Nut, Hex Jam ½ - 13	012538	27	Knob, Thermostat	003908
13	Spacer, Rear	012814	28	Label, Raise - Lower	051471
14	Washer, Plain	005598	29	Knob, Plastic	002408
15	Switch, Momentary Toggle	002664	30	Bullet Leg Assembly	003597
16	Thermostat, High Limit	012840	31	Flanged Base Leg Assembly	003598
17	Heater, Strip, 208 Volt	012842	32	Cover & Handle Assembly, 3-Pan	048789
	Heater, Strip, 240-380 Volt	012843		Cover & Handle Assembly, 4-an	046450
	Heater, Strip, 480 Volt	012908	33	Clamp, Heater Strip	012844

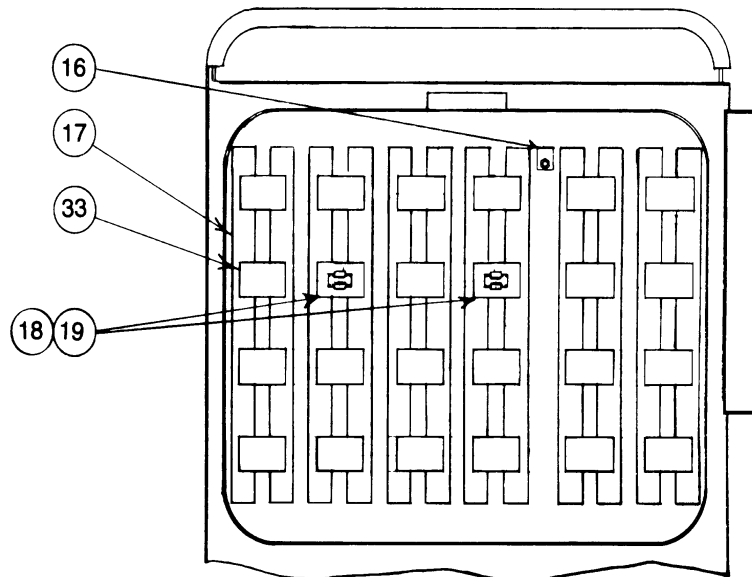

(Underside View of Pan Body)

OM-CFPC

Wiring Diagrams

For certain models of CFPC/2, all units manufactured after January 1, 1985, have been wired for three phase power supply. The models affected are:

Size 3, 208 Volt Size 3, 240 Volt Size 4, 208 Volt Size 4, 240 Volt

If one of these braising pans will be used with single phase supply, it must be field converted as shown in the Phase Conversion Diagram, below.

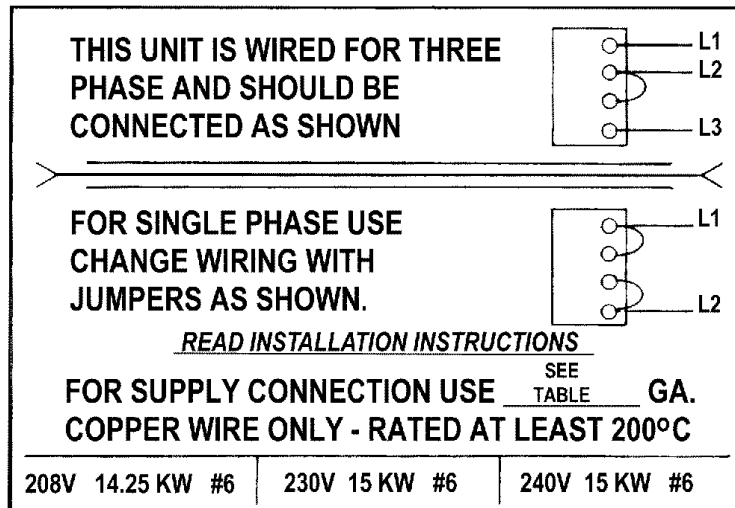

A-9010-7

Note: See Figure 1, page 14

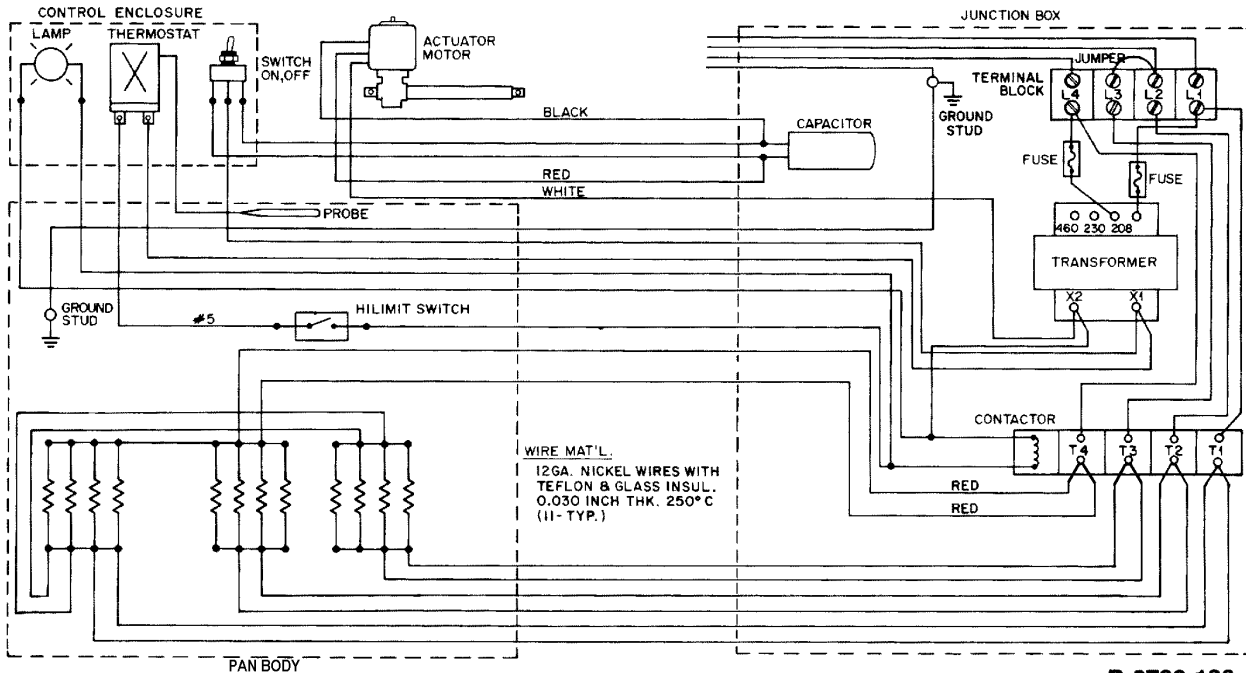

B-8720-126

NOTES:
14.25 KW AT 208 V
15 KW AT 230 / 240V
FOR SINGLE PHASE CONNECTION
SEE LABEL OR DWG No. a-9010-7

**CFPC/2-3, 208 and 240V, 1 and 3 PH
manufactured after January 1, 1985**

Wiring Diagrams

Note: See Figure 1, page 14

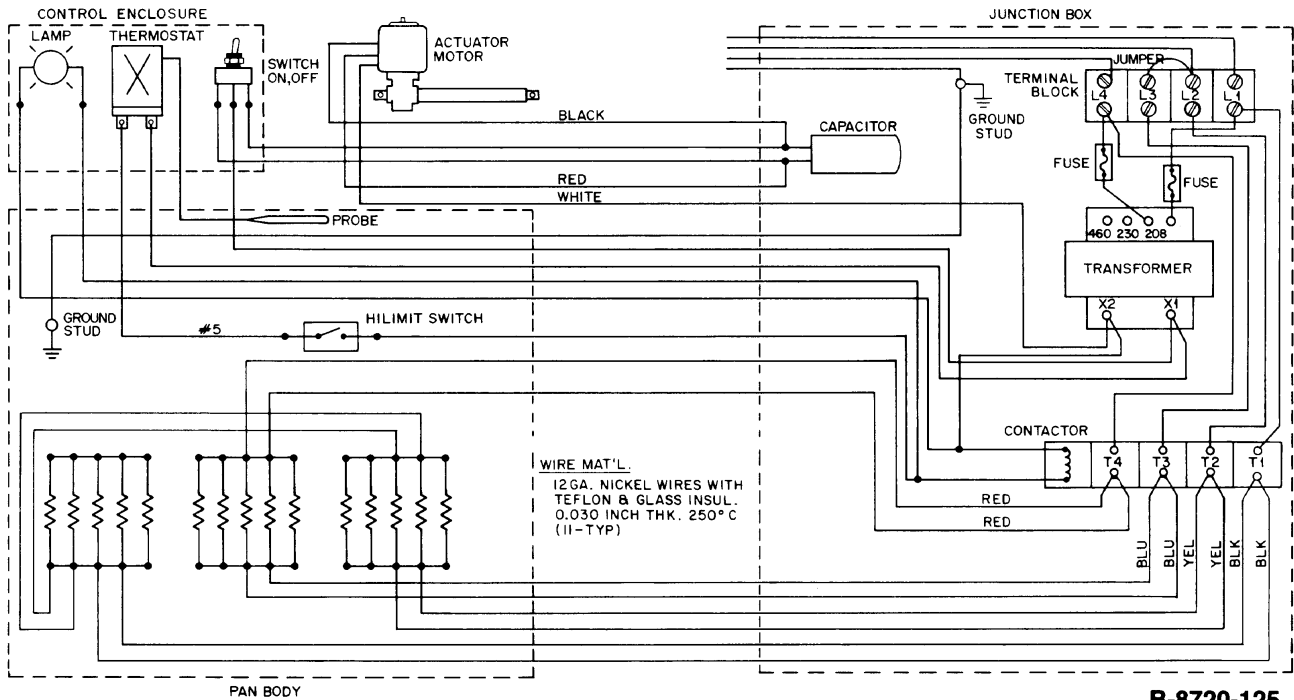

B-8720-125

NOTES:
14.25KW AT 208V
12 KW AT 230 / 240V
FOR SINGLE PHASE CONNECTION
SEE LABEL OR DWG NO. A-9010-7.

**CFPC/2-4, 208 and 240V, 1 and 3 PH
manufactured after January 1, 1985**

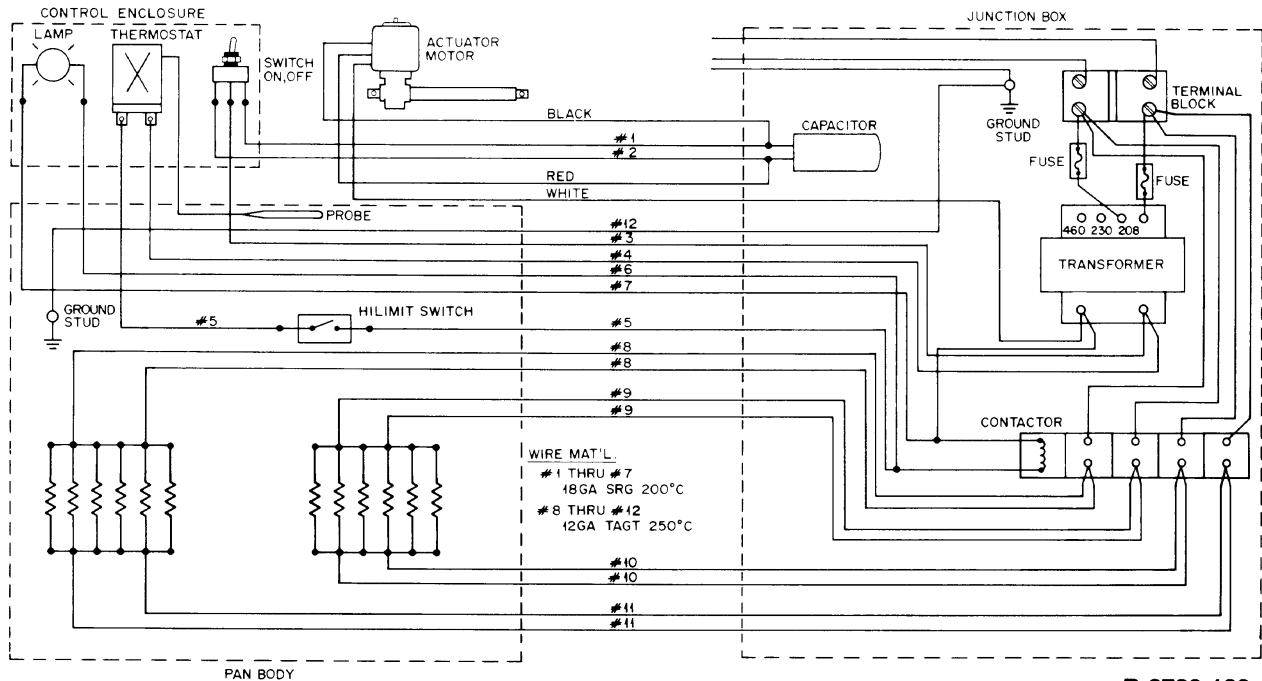

B-8720-128

NOTES:
11.4 KW AT 208V

**CFPC-3 and CFPC/2-3, 208 V, 1 PH
manufactured before January 1, 1985**

OM-CFPC

Wiring Diagrams

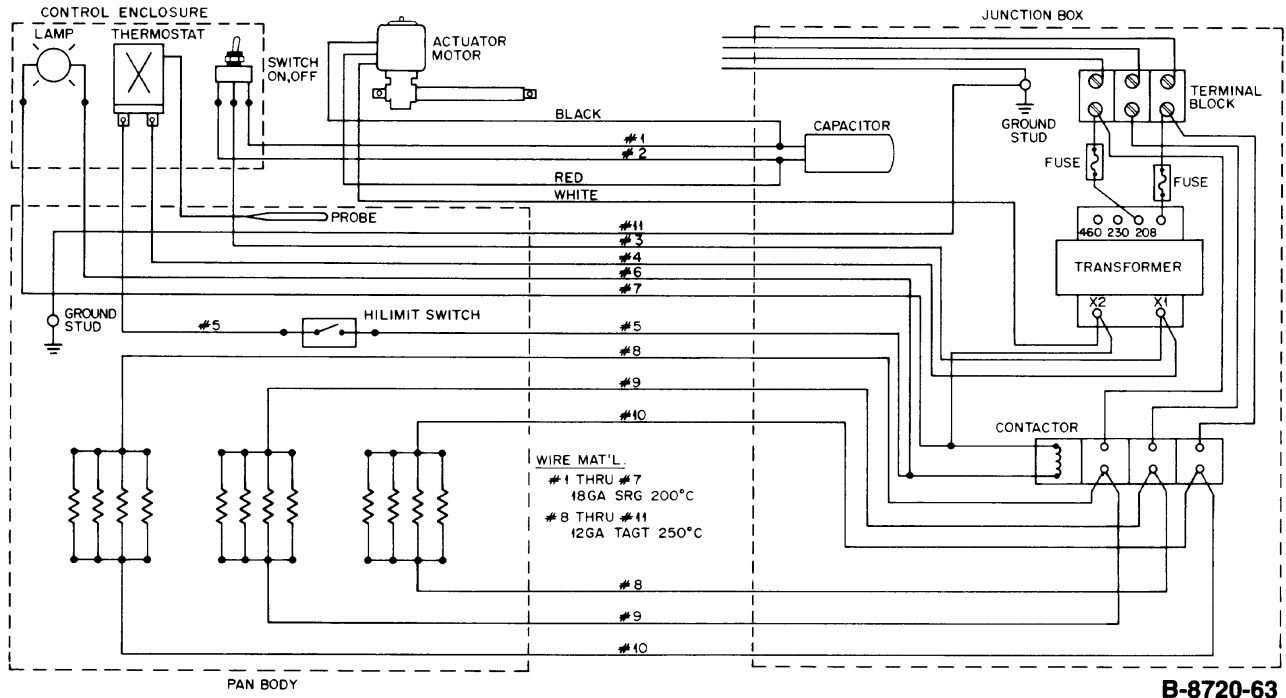

B-8720-63

NOTES:
11.4 KW AT 208V

**CFPC-3 and CFPC/2-3, 208 V, 3 PH
manufactured before January 1, 1985**

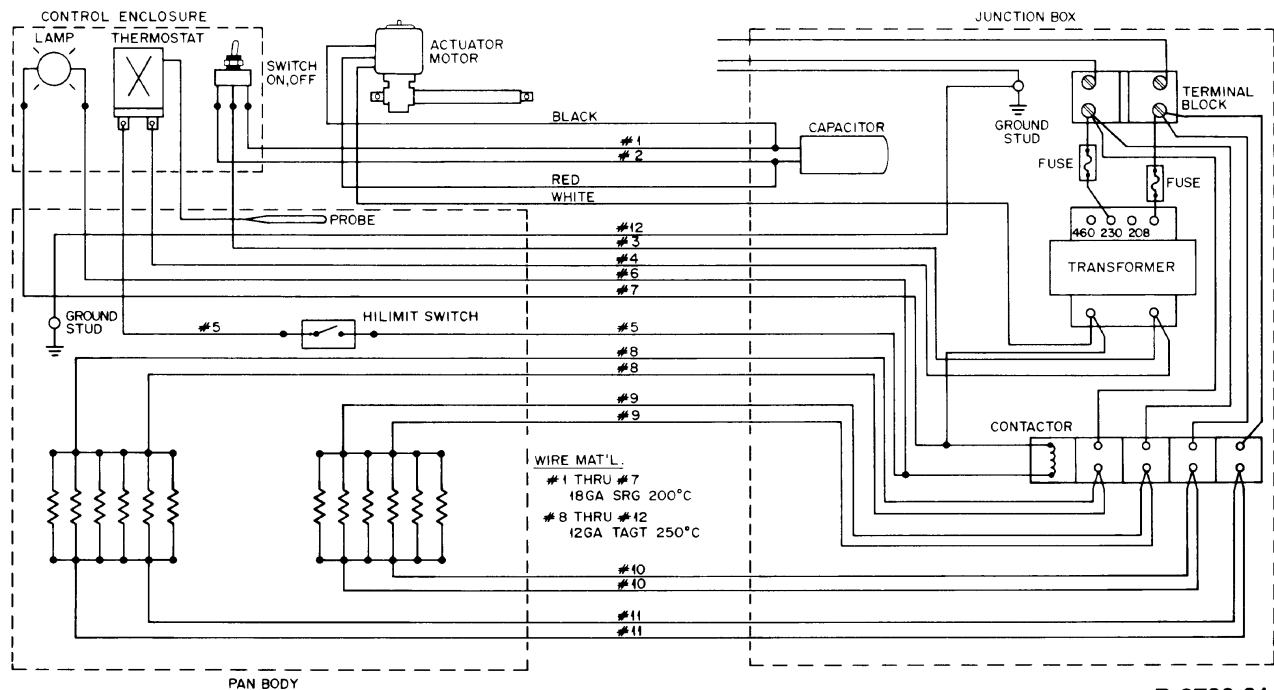

B-8720-81

NOTES:
12 KW AT 240V

**CFPC-3 and CFPC/2-3, 240 V, 1 PH
manufactured before January 1, 1987**

Wiring Diagrams

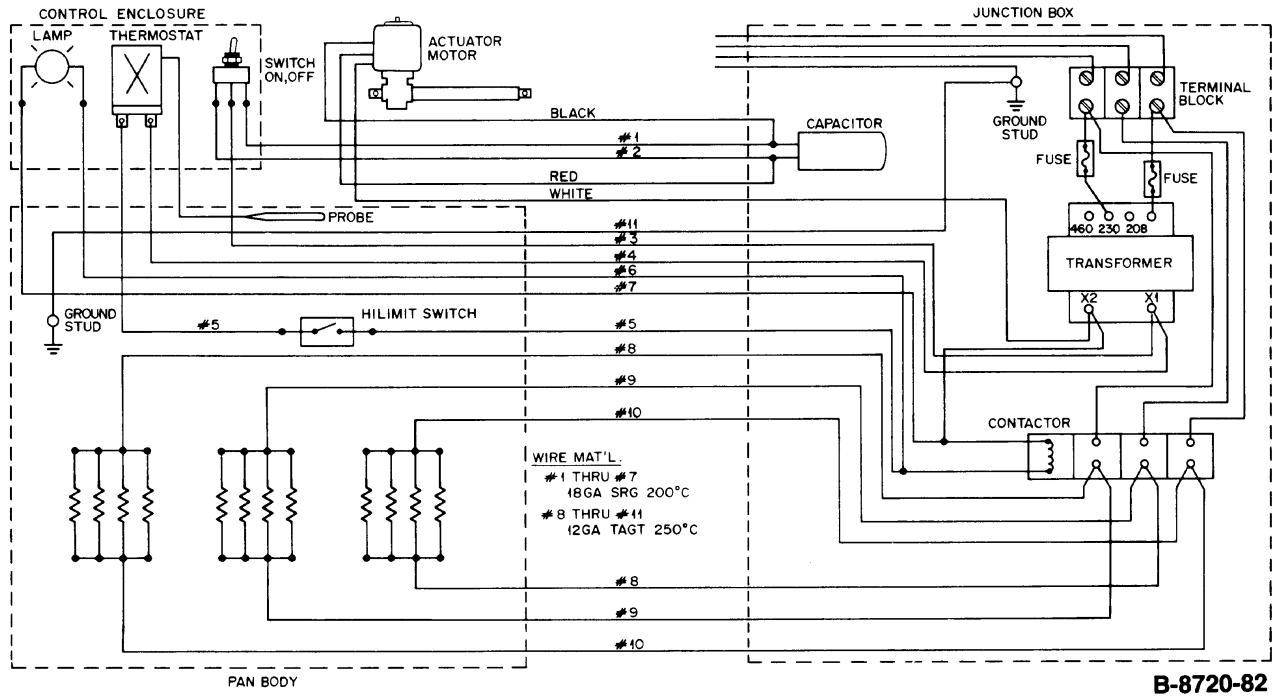

NOTES:
 1. 12KW AT 240 V
 2. FOR BRAISING PANS BUILT AFTER
 JANUARY 1, 1985 USE DWG 3-8720-125

CFPC-3 and CFPC/2-3, 240 V, 3 PH
 manufactured before January 1, 1985

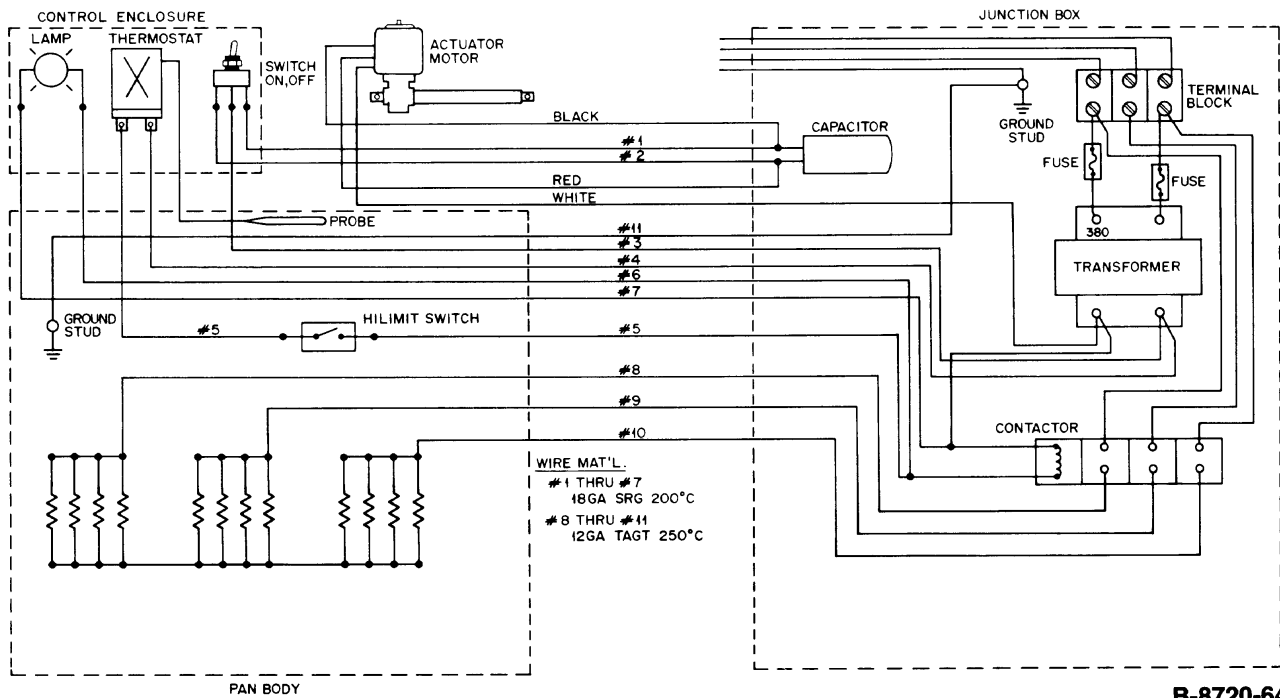

NOTES:
 12 KW AT 380V

CFPC-3 and CFPC/2-3, 380 V, 3 PH

OM-CFPC

Wiring Diagrams

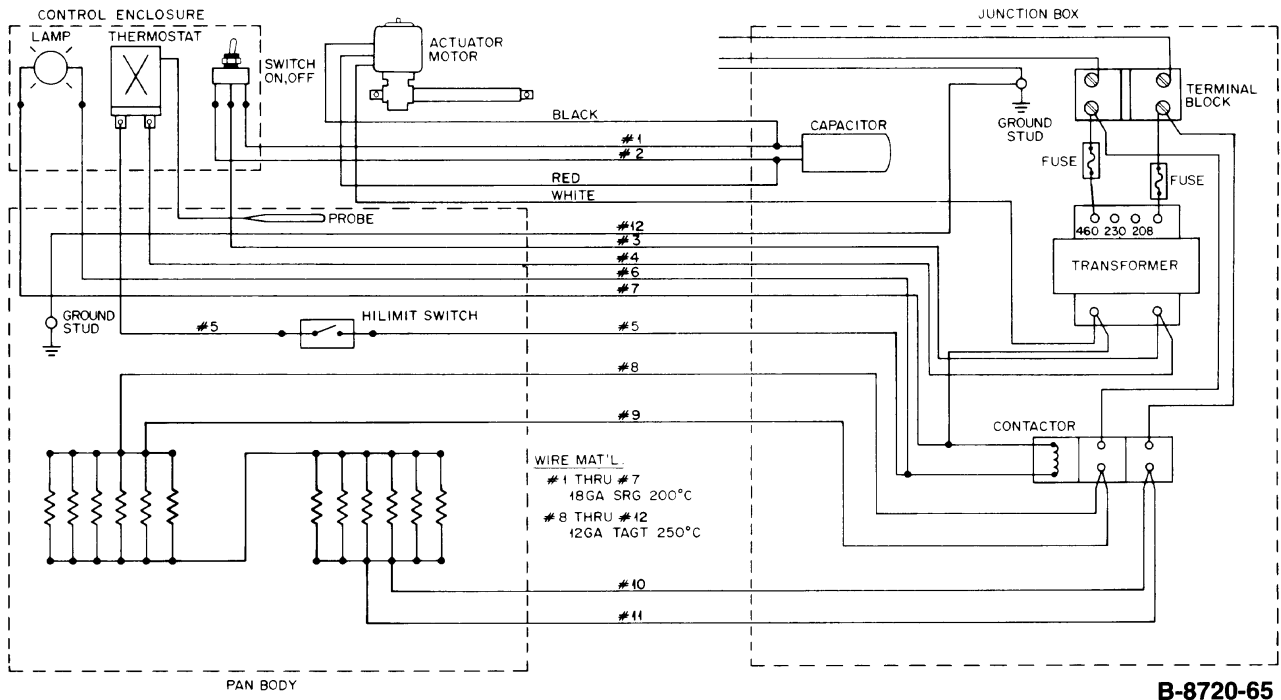

NOTES:
12KW AT 480V

B-8720-65

CFPC-3 and CFPC/2-3, 480 V, 1 PH

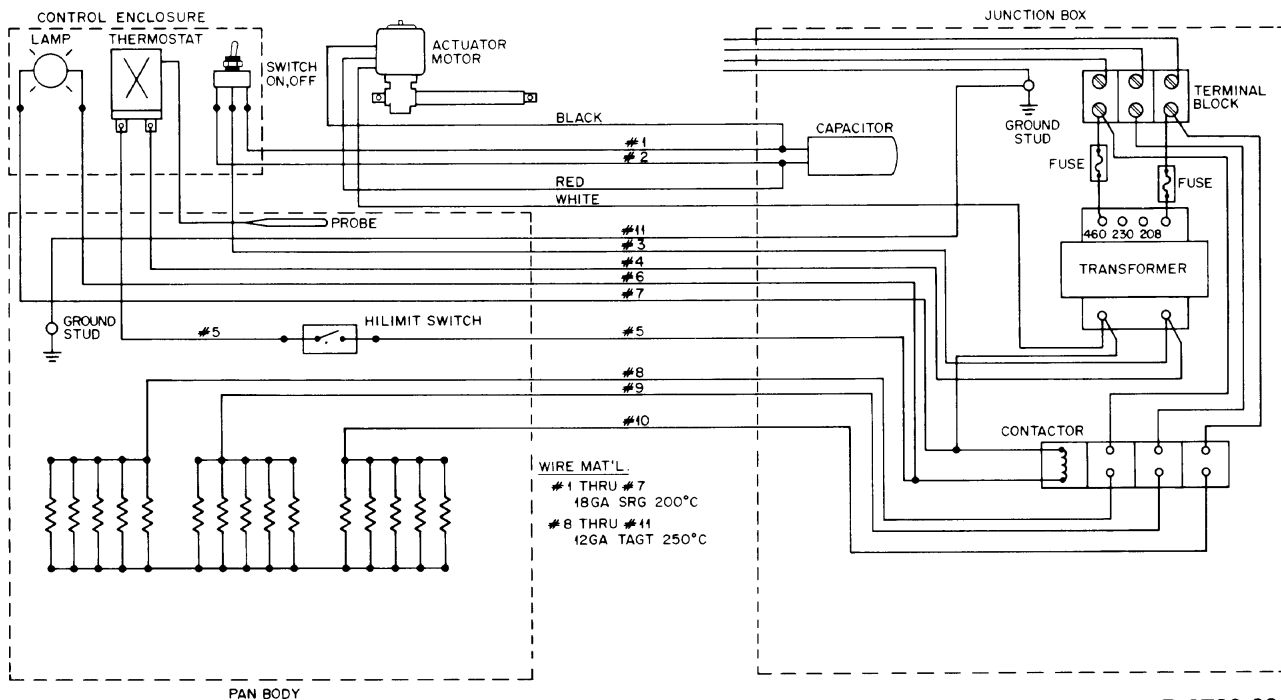

NOTES:
12 KW AT 480V

B-8720-66

CFPC-3 and CFPC/2-3, 480 V, 3 PH

Wiring Diagrams

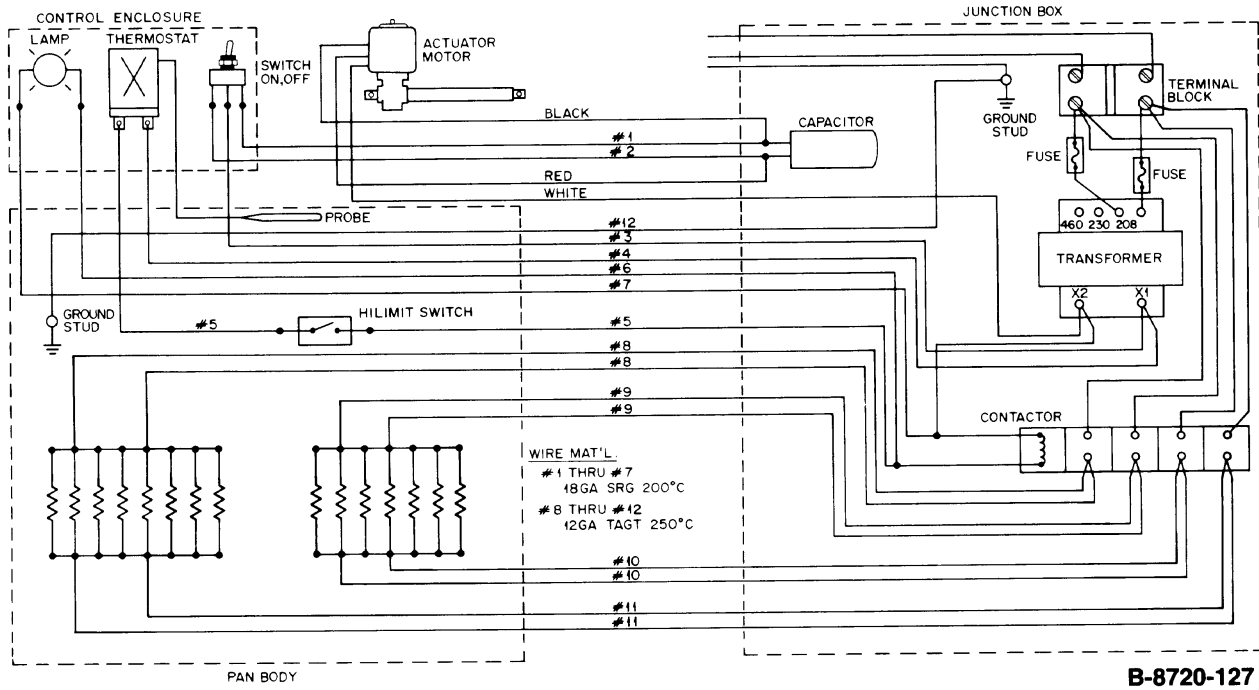

NOTES:
14.25KW AT 208V

**CFPC-4 and CFPC/2-4, 208 V, 1 PH
manufactured before January 1, 1985**

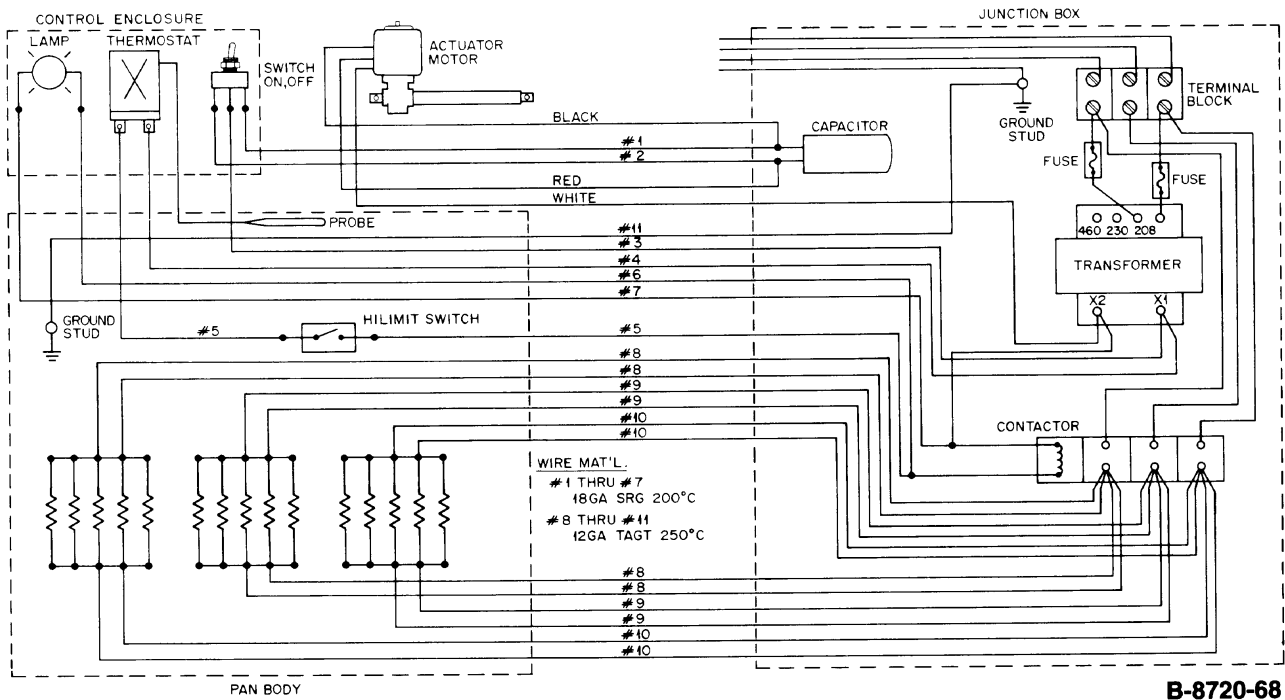

NOTES:
14.25KW AT 208V

**CFPC-4 and CFPC/2-4, 208 V, 3 PH
manufactured before January 1, 1985**

OM-CFPC

Wiring Diagrams

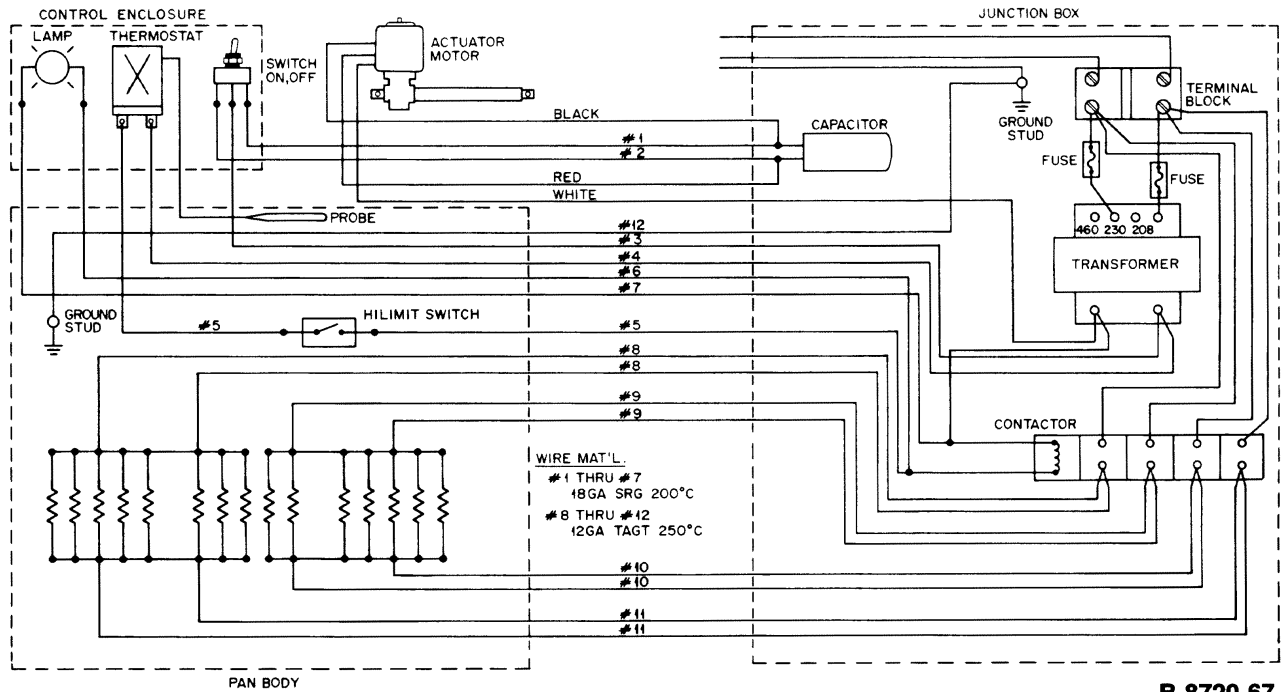

NOTES:
15.0 KW AT 240V

B-8720-67

**CFPC-4 and CFPC/2-4, 240 V, 1 PH
manufactured before January 1, 1985**

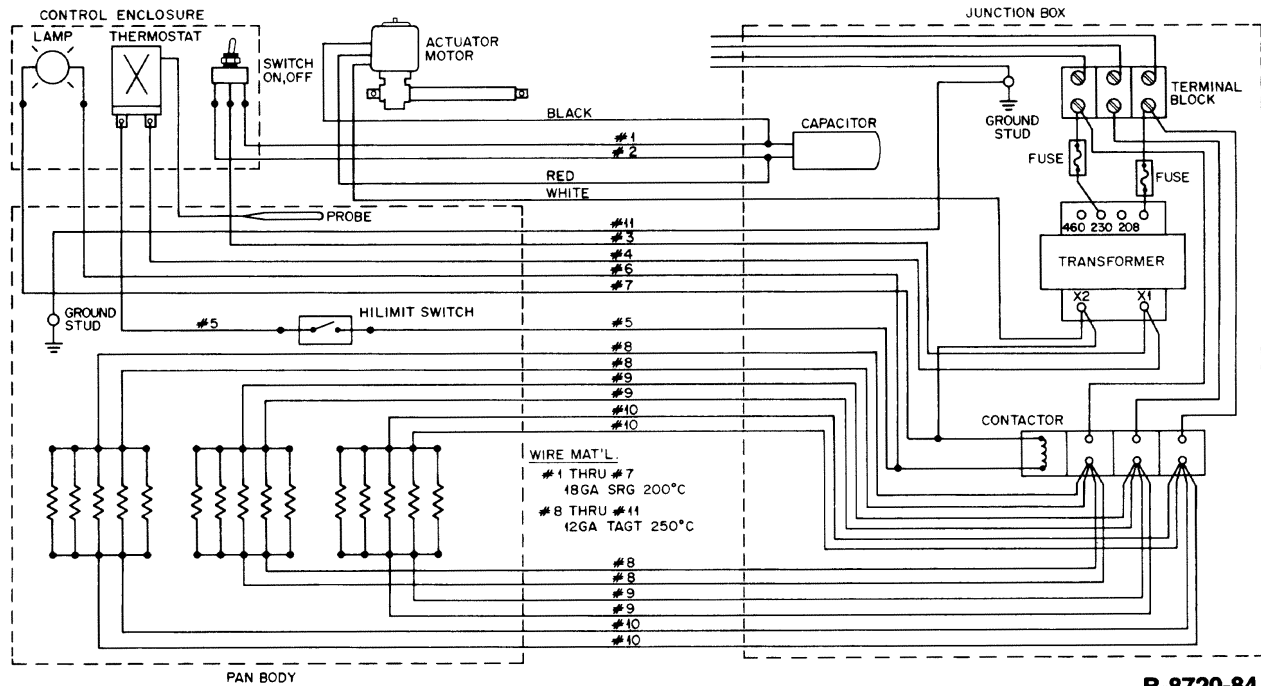

NOTES:
15.0 KW AT 240V

B-8720-84

**CFPC-4 and CFPC/2-4, 240 V, 3 PH
manufactured before January 1, 1985**

Wiring Diagrams

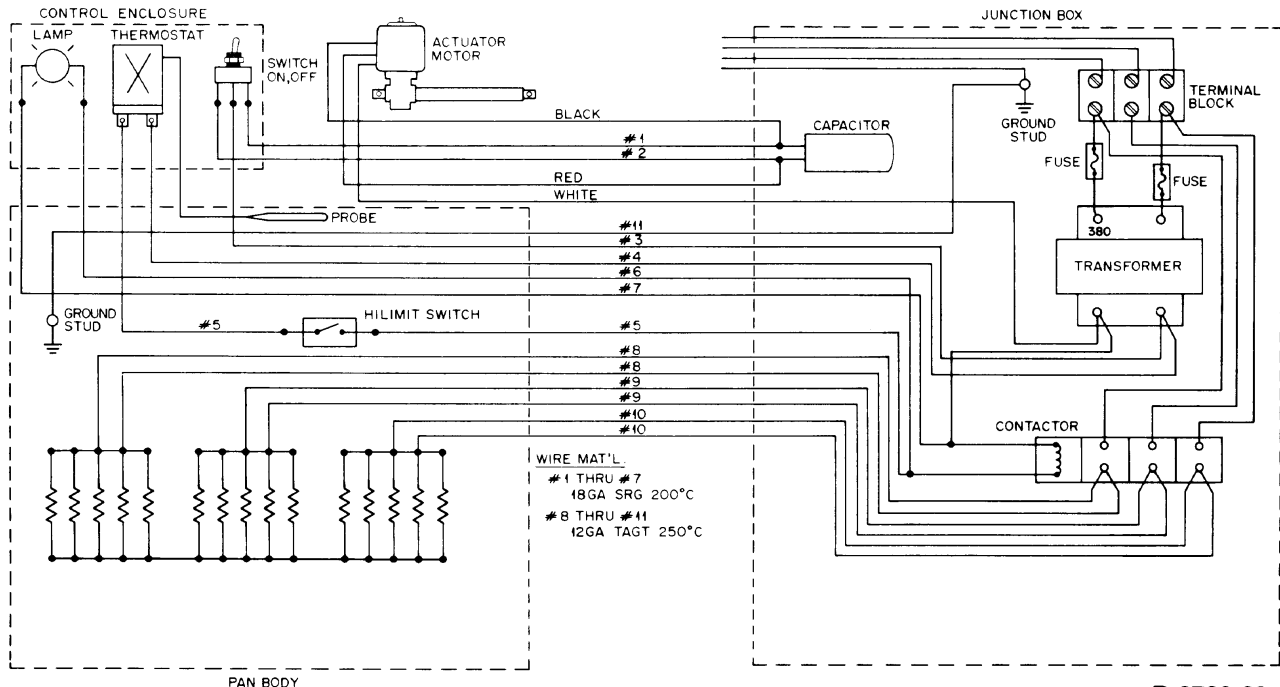

NOTES:
15 KW AT 380V

B-8720-69

CFPC-4 and CFPC/2-4, 380 V, 3 PH

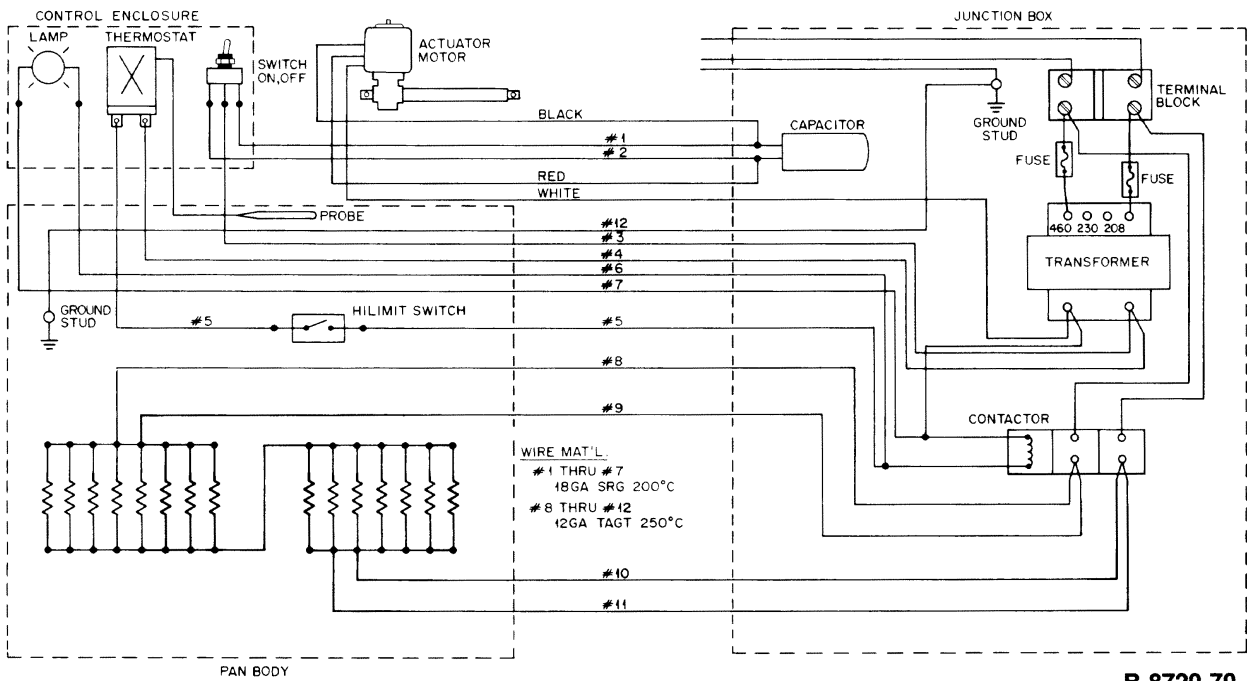

NOTES:
15 KW AT 480V

B-8720-70

CFPC-4 and CFPC/2-4, 480 V, 1 PH

OM-CFPC

Wiring Diagrams

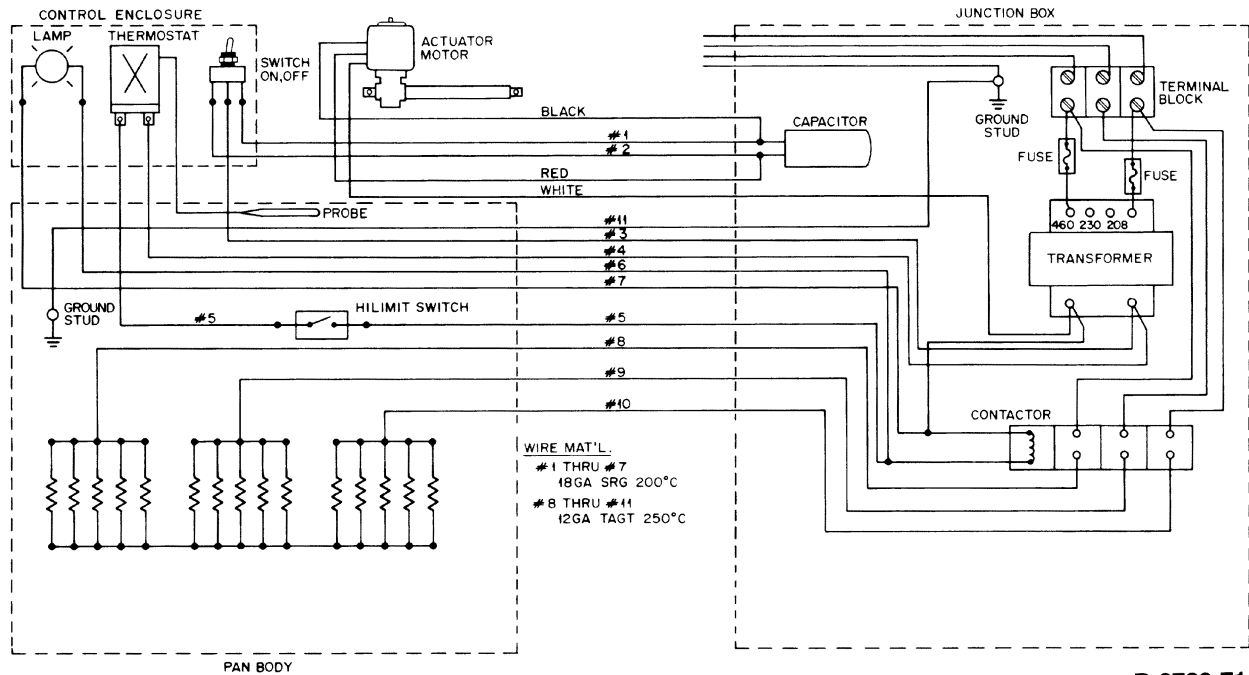

NOTES:
15 KW AT 480V

B-8720-71

CFPC-4 and CFPC/2-4, 480 V, 3 PH

References

KLENZADE SALES CENTER
ECOLAB, Inc.
370 Wabasha
St. Paul, Minnesota 55102
800 328-3663 or 612 293-2233

NATIONAL FIRE PROTECTION ASSOCIATION
60 Battery March Park
Quincy, Massachusetts 02269

NFPA The National Electrical Code

NATIONAL SANITATION FOUNDATION
3475 Plymouth Rd.
Ann Arbor, Michigan 48106

UNDERWRITERS LABORATORIES, INC.
333 Pfingsten Rd.
Northbrook, Illinois 60062

ZEP MANUFACTURING
1390 Lunt Avenue
Elk Grove Village, Illinois 60007

Limited Warranty To Commercial Purchasers *

(Domestic U.S., Hawaii &
Canadian Sales Only)

Groen Foodservice Equipment ("Groen Equipment") has been skillfully manufactured, carefully inspected and packaged to meet rigid standards of excellence. Groen warrants its Equipment to be free from defects in material and workmanship for (12) twelve months with the following conditions and subject to the following limitations.

- I. This parts and labor warranty is limited to Groen Equipment sold to the original commercial purchaser/users (but not original equipment manufacturers), at its original place of installation in the continental United States, Hawaii and Canada.
- II. Damage during shipment is to be reported to the carrier, is not covered under this warranty, and is the sole responsibility of purchaser/user.
- III. Groen, or an authorized service representative, will repair or replace, at Groen's sole election, any Groen Equipment, including but not limited to, draw-off valves, safety valves, gas and electric components, found to be defective during the warranty period. As to warranty service in the territory described above, Groen will absorb labor and portal to portal transportation costs (time & mileage) for the first twelve (12) months from date of installation or fifteen (15) months from date of shipment from Groen.
- IV. This warranty does not cover boiler maintenance, calibration, periodic adjustments as specified in operating instructions or manuals, and consumable parts such as scraper blades, gaskets, packing, etc., or labor costs incurred for removal of adjacent equipment or objects to gain access to Groen Equipment. This warranty does not cover defects caused by improper installation, abuse, careless operation, or improper maintenance of equipment. This warranty does not cover damage caused by poor water quality or improper boiler maintenance.
- V. THIS WARRANTY IS EXCLUSIVE AND IS IN LIEU OF ALL OTHER WARRANTIES, EXPRESSED OR IMPLIED, INCLUDING ANY IMPLIED WARRANTY OF MERCHANTABILITY OR FITNESS FOR A PARTICULAR PURPOSE, EACH OF WHICH IS HEREBY EXPRESSLY DISCLAIMED. THE REMEDIES DESCRIBED ABOVE ARE EXCLUSIVE AND IN NO EVENT SHALL GROEN BE LIABLE FOR SPECIAL, CONSEQUENTIAL OR INCIDENTAL DAMAGES FOR THE BREACH OR DELAY IN PERFORMANCE OF THIS WARRANTY.
- VI. Groen Equipment is for commercial use only. If sold as a component of another (O.E.M.) manufacturer's equipment, or if used as a consumer product, such Equipment is sold AS IS and without any warranty.

* (Covers All Foodservice Equipment Ordered After October 1, 1995)

NOTES

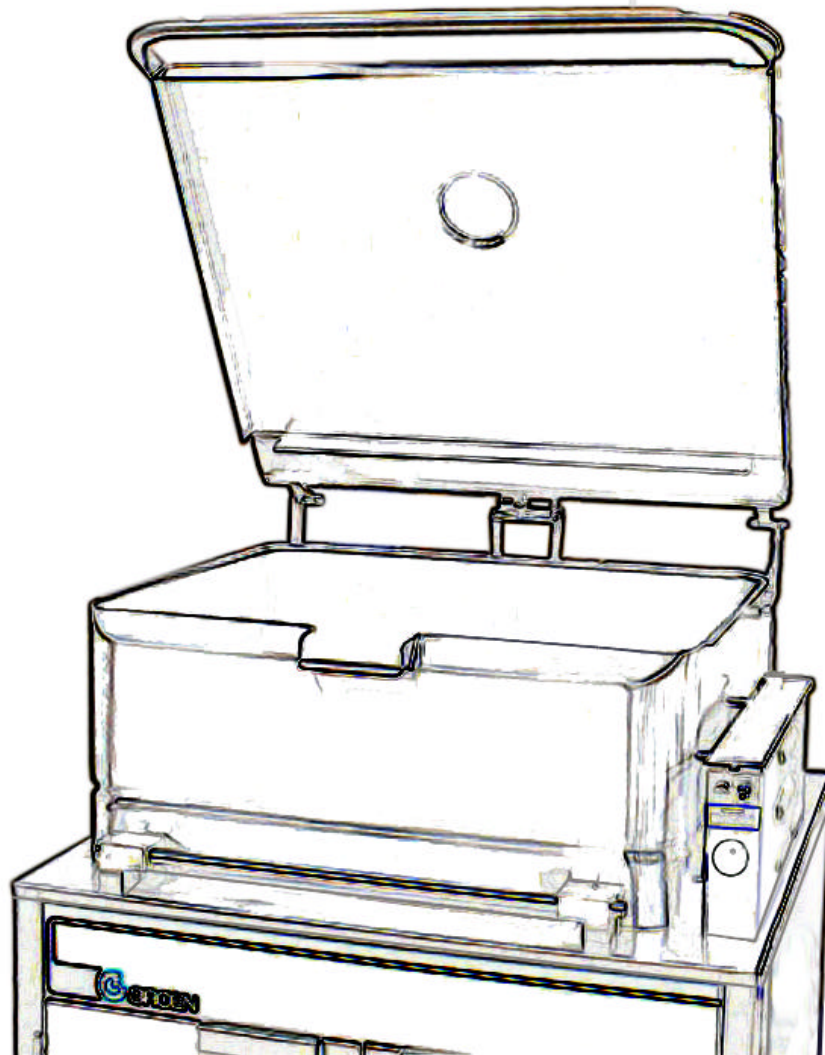

1055 Mendell Davis Drive
Jackson, MS 39212
Telephone 601 372-3903
FAX 601 373-9587

OM-CFPC (Revised 10/98)
Part Number 121028