

OPERATOR MANUAL

Part Number 121031

OM-CHFP

DOMESTIC

**MODELS: CHFP/1, CHFP/1-E
CHFP/2, CHFP/2-E
Braising Pans**

*Stainless Steel
Cabinet Mounted
Power Tilting
Gas Heated*



THIS MANUAL MUST BE RETAINED FOR FUTURE REFERENCE. READ, UNDERSTAND AND FOLLOW THE INSTRUCTIONS AND WARNINGS CONTAINED IN THIS MANUAL.

WARNING

DO NOT STORE OR USE GASOLINE OR OTHER FLAMMABLE VAPORS AND LIQUIDS IN THE VICINITY OF THIS OR ANY OTHER APPLIANCE.

POST IN A PROMINENT LOCATION

INSTRUCTIONS TO BE FOLLOWED IN THE EVENT USER SMELLS GAS. THIS INFORMATION SHALL BE OBTAINED BY CONSULTING YOUR LOCAL GAS SUPPLIER. AS A MINIMUM, TURN OFF THE GAS AND CALL YOUR GAS COMPANY AND YOUR AUTHORIZED SERVICE AGENT. EVACUATE ALL PERSONNEL FROM THE AREA.

WARNING

IMPROPER INSTALLATION, ADJUSTMENT, ALTERATION, SERVICE OR MAINTENANCE CAN CAUSE PROPERTY DAMAGE, INJURY OR DEATH. READ THE INSTALLATION, OPERATING AND MAINTENANCE INSTRUCTIONS THOROUGHLY BEFORE INSTALLING OR SERVICING THIS EQUIPMENT.



IMPORTANT — READ FIRST — IMPORTANT

- CAUTION:** HIPPIING STRAPS ARE UNDER TENSION AND CAN SNAP BACK WHEN CUT.
- CAUTION:** UNIT WEIGHS 585 TO 720 LB. (266 TO 327 KG). FOR SAFE HANDLING, INSTALLER SHOULD OBTAIN HELP AS NEEDED, OR EMPLOY APPROPRIATE MATERIALS HANDLING EQUIPMENT (SUCH AS A FORKLIFT, DOLLY, OR PALLET JACK) TO REMOVE THE UNIT FROM THE SKID AND MOVE IT TO THE PLACE OF INSTALLATION.
- WARNING:** INSTALLATION OF THE BRAISING PAN MUST BE DONE BY PERSONNEL QUALIFIED TO WORK WITH GAS AND ELECTRICITY. IMPROPER INSTALLATION CAN RESULT IN INJURY TO PERSONNEL AND/OR DAMAGE TO EQUIPMENT.
- WARNING:** THIS UNIT IS DESIGNED FOR COMMERCIAL USE. NEVER USE HOME OR RESIDENTIAL GRADE GAS CONNECTIONS. THEY DO NOT MEET GAS CODES AND COULD BE HAZARDOUS.
- DANGER:** ELECTRICALLY GROUND THE UNIT AT THE TERMINAL PROVIDED. FAILURE TO GROUND UNIT COULD RESULT IN ELECTROCUTION AND DEATH.
- WARNING:** KEEP THE APPLIANCE AREA FREE AND CLEAR OF COMBUSTIBLE MATERIALS.
- CAUTION:** BE SURE ALL OPERATORS READ, UNDERSTAND AND FOLLOW THE OPERATING INSTRUCTIONS, CAUTIONS AND SAFETY INSTRUCTIONS CONTAINED IN THIS MANUAL.
- CAUTION:** KEEP FLOORS IN BRAISING PAN WORK AREA CLEAN AND DRY. IF SPILLS OCCUR, CLEAN IMMEDIATELY TO AVOID THE DANGER OF SLIPS OR FALLS.
- WARNING:** WHEN TILTING BRAISING PAN FOR PRODUCT TRANSFER:
- 1) USE CONTAINER DEEP ENOUGH TO CONTAIN AND MINIMIZE PRODUCT SPLASHING.
 - 2) PLACE CONTAINER ON STABLE, FLAT SURFACE, AS CLOSE TO PAN AS POSSIBLE.
 - 3) STAND TO SIDE OF PAN WHILE POURING — NOT DIRECTLY IN POUR PATH OF HOT CONTENTS.
 - 4) RETURN PAN BODY TO LEVEL POSITION AFTER CONTAINER IS FILLED OR TRANSFER IS COMPLETE.
 - 5) DO NOT OVER FILL CONTAINER. AVOID DIRECT SKIN CONTACT WITH HOT CONTAINER AND ITS CONTENTS.
- WARNING:** DO NOT HEAT AN EMPTY PAN FOR MORE THAN 5 MINUTES AT A SETTING HIGHER THAN 300°F.
- WARNING:** IF THE PAN CONTAINS ITEMS IN SAUCE OR MELTED FAT, THEY CAN SLIDE FORWARD SUDDENLY DURING TILTING AND CAUSE THE HOT LIQUID TO SPLASH OUT.
- WARNING:** AVOID ALL DIRECT CONTACT WITH HOT FOOD OR WATER IN THE PAN. DIRECT CONTACT COULD RESULT IN SEVERE BURNS.
- WARNING:** KEEP WATER AND SOLUTIONS OUT OF CONTROLS AND BURNERS. NEVER SPRAY OR HOSE THE CONTROL CONSOLE, OR ELECTRICAL CONNECTIONS.
- CAUTION:** MOST CLEANERS ARE HARMFUL TO THE SKIN, EYES, MUCOUS MEMBRANES AND CLOTHING. PRECAUTIONS SHOULD BE TAKEN TO WEAR RUBBER GLOVES, GOGGLES OR FACE SHIELD AND PROTECTIVE CLOTHING. CAREFULLY READ THE WARNINGS AND FOLLOW THE DIRECTIONS ON THE LABEL OF THE CLEANER TO BE USED.
- WARNING:** THE CONTROL BOX IS NOT WATERPROOF. TAKE CARE TO KEEP WATER AND CLEANING SOLUTIONS OUT OF THE BOX. NEVER HOSE OR SPRAY ELECTRICAL CONTROLS, CONNECTIONS OR CONTROL CONSOLE.
- WARNING:** BEFORE REPLACING ANY PARTS, DISCONNECT THE UNIT FROM THE ELECTRIC POWER SUPPLY AND CLOSE THE MAIN GAS COCK. ALLOW FIVE MINUTES FOR UNBURNED GAS TO VENT.
- CAUTION:** USE OF ANY REPLACEMENT PARTS OTHER THAN THOSE SUPPLIED BY GROEN OR AUTHORIZED DISTRIBUTORS CAN CAUSE INJURY TO THE OPERATOR AND DAMAGE TO THE EQUIPMENT AND WILL VOID ALL WARRANTIES.
- IMPORTANT:** Service performed by other than factory authorized personnel will void all warranties.

Table of Contents

IMPORTANT OPERATOR WARNINGS (READ FIRST) 2

EQUIPMENT DESCRIPTION 4

INSPECTION AND UNPACKING 5

INSTALLATION 6

INITIAL START-UP 7

OPERATION 7

SEQUENCE OF OPERATION 10

CLEANING 11

MAINTENANCE 12

TROUBLESHOOTING 13

PARTS LIST 16

DIAGRAMS & SCHEMATICS 20

MAINTENANCE LOG 25

REFERENCES 26

WARRANTY 27

OM-CHFP

Equipment Description

Groen Gas Heated Braising Pans provide a stainless steel pan equipped with patented heat transfer fins, burner/combustion chamber, power tilting mechanism, thermostatic controls, and hinged cover. The Braising Pan can serve as braising unit, griddle, fry pan, oven, kettle, bain-marie, or food warmer and server, and it can be adapted for use as a steamer.

The pan body is made from heavy-duty stainless steel welded into one solid piece, with a polished interior and exterior. A pouring lip is welded to the front wall. The cooking surface is a stainless steel clad plate fitted with welded heat transfer fins which assure uniform heat transfer over the entire surface. The gas burner/combustion chamber supplies the heat.

The thermostat and tilting switch are contained in a compact control console which is mounted beside the pan body.

An electrically powered mechanism tilts the pan forward. A three position switch on the front of the control console gives the operator positive, smooth-acting control of pan body tilt.

The thermostat provides automatic control of cooking temperature. Operating the thermostat dial on the front of the control console turns the heat on or off and sets the pan temperature.

A vented, heavy gauge, one-piece, stainless steel cover with a condensate drip shield on the rear edge is standard on the Braising Pan. A fully enclosed, spring type actuator counter-balances the cover to keep it in either the opened or closed position. The cover opens to the back and is hinged to the frame, so it moves independently of the pan body.

The pan is mounted on a double-door cabinet with friction latches. The cabinet exterior is polished to a uniform m 4 finish, and accented on the front with a color strip. A removable pan support is provided as standard equipment.

CHFP/2 Models are distinguished from Model CHFP/1 by several characteristics. CHFP/2 units have higher firing rates, slightly wider pans, and a manual override feature in the tilting mechanism. Models of CHFP also differ in their ignition systems.

CHFP/1 and CHFP/2 Models have a standing flame pilot light that ignites the main burner.. Model CHFP/1/E has an electronic ignition system which employs an intermittent spark. CHFP/2/E also has an electronic ignition system, but it uses a carborundum glow coil igniter. Installation of any CHFP model requires connection to gas and to 115 Volt electric power.

CHARACTERISTICS AND PERFORMANCE DATA

Model	Pan Dimensions			Ignition	Firing Rate BTU/hr	Heat into Product BTU/hr
	Left to Right	Front to Back	Depth			
CHFP/1-3	31" (787 mm)	24" (610 mm)	7" or 9" (18 or 23cm)	Flame	90,000	54,000
CHFP/1E-3	31" (787mm)	24" (610 mm)	7" or 9" (18 or 23cm)	Spark	90,000	54,000
CHFP/1-4	41" (1041 mm)	24" (610 mm)	7" or 9" (18 or 23cm)	Flame	120,000	70,000
CHFP/1E-4	41" (1041mm)	24" (610 mm)	7" or 9" (18 or 23cm)	Spark	120,000	70,000
CHFP/2-3	31e" (803 mm)	25" (635 mm)	7" or 9" (18 or 23cm)	Flame	104,000	67,600
CHFP/2E-3	31e" (803 mm)	25" (635 mm)	7" or 9" (18 or 23cm)	Coil	104,000	67,600
CHFP/2-4	41e" (1057 mm)	25" (635 mm)	7" or 9" (18 or 23cm)	Flame	144,000	93,600
CHFP/2E-4	41e" (1057mm)	25" (635 mm)	7" or 9" (18 or 23cm)	Coil	144,000	93,600

Inspection and Unpacking

The unit will arrive completely assembled, wrapped in protective plastic on a heavy skid, in a heavy cardboard carton. Immediately upon receipt, inspect the carton for damage. Report any apparent shipping damage or an incorrect shipment to the delivery agent.

When installation is to begin, get someone to assist in removing the carton. Lift it straight up and away from the unit. **Do not simply raise it and push backwards - you will break the cover assembly vent handle.** Write down the model number, serial number, and installation date of your unit, and keep this information for future reference. Space for these entries is provided at the top of the Service Log in this manual.

Cut the straps holding the unit on the skid, and lift the unit straight up off the skid.

CAUTION

SHIPPING STRAPS ARE UNDER TENSION AND CAN SNAP BACK WHEN CUT.

UNIT WEIGHS 585 TO 720 LB. (266 TO 327 KG). FOR SAFE HANDLING, INSTALLER SHOULD OBTAIN HELP AS NEEDED, OR EMPLOY APPROPRIATE MATERIALS HANDLING EQUIPMENT (SUCH AS A FORKLIFT, DOLLY, OR PALLET JACK) TO REMOVE THE UNIT FROM THE SKID AND MOVE IT TO THE PLACE OF INSTALLATION.



Installation

The Braising Pan should be installed in a ventilated room for efficient performance. Items which might obstruct or restrict the flow of air for combustion and ventilation must be removed. The area directly around the braising pan must be cleared of all combustible material.

WARNING
INSTALLATION OF THE BRAISING PAN MUST BE DONE BY PERSONNEL QUALIFIED TO WORK WITH GAS AND ELECTRICITY. IMPROPER INSTALLATION CAN RESULT IN INJURY TO PERSONNEL AND/OR DAMAGE TO EQUIPMENT.

1. Installation on combustible floors is allowed, with a minimum clearance to combustible and noncombustible construction of six inches at the rear, five inches at the right side and zero inches on the left.
2. The must be installed under a vent hood. Installation of the vent hood must also comply with local codes and/or ANSI/NFPA 70 - latest edition.
3. Level the unit by adjusting it legs. Make sure that the tilting mechanism has been run all the way to the horizontal position. Check levelness front to rear and side to side by placing a spirit level on the bottom of the pan body.
4. The Braising Pan should be electrically interlocked to shut off the gas supply and prevent operation of the unit if the exhaust fan is not operating or the fire suppression system is activated.
5. Complete the piping to the gas service by using ½ inch IPS pipe or approved equivalent.

WARNING:
THIS UNIT IS FOR COMMERCIAL USE. NEVER USE HOME OR RESIDENTIAL GRADE GAS CONNECTIONS. THEY DO NOT MEET GAS CODES AND COULD BE HAZARDOUS.

6. The installation must conform with local codes or with the American National Standard Z223, latest edition, National Fuel Gas Code. The pan should be

installed in an adequately ventilated room with a provision for adequate air supply to the unit. The best ventilation will use a vent hood and exhaust fan. DO NOT obstruct the flue or vent duct after installation. **In Canada**, installation must conform to CAN/CGA B149 Installation Codes for Gas Appliances and Equipment and/or local codes.



WARNING
ELECTRICALLY GROUND THE UNIT AT THE TERMINAL PROVIDED. FAILURE TO GROUND UNIT COULD RESULT IN ELECTROCUTION AND DEATH.

7. For models with hot surface ignition, provide 115 VAC, 60 HZ, 1 phase, 5 AMP electrical service through the rear of the electrical console. (See Pages 16 and 18). Local codes and/or The National Electrical Code should be observed in accordance with ANSI/NFPA70, latest edition. **AN ELECTRICAL GROUND IS REQUIRED.** The electrical schematic is located on the inside of the service panel and at the rear of this manual. **In Canada**, provide electrical service in accordance with the Canadian Electrical Code, CSA-C22.1 Part 1 and/or local codes.
8. Adequate space for proper servicing and operation is required. DO NOT block any air intake spacings to the combustion chamber or obstruct air flow.
9. After the pan has been connected to the gas supply, check all gas joints for leaks. A soap solution or other suitable leak detector should be used. **Do not use flame to check for leaks.**

10. The appliance and its individual shutoff valve must be **protected** from the gas supply piping system during any system pressure testing at test pressures **in excess of ½ PSI (3.45 kPa)**.

The appliance must be **isolated** from the gas supply piping system by closing its individual manual shutoff valve during any pressure testing of the gas supply piping system.

Initial Start-Up

Now that the unit has been installed, you should test your Braising Pan to ensure that it is operating correctly.

1. Remove literature and packing materials from the interior and exterior of the unit.
2. Put enough water into the pan to cover the bottom to a depth of ¼ to ½ inch. With the pan body in the horizontal position, note how the water lies in the pan, to confirm that the pan was leveled properly during installation.
3. Following "To Start Pan" instructions for your pan model, begin heating the water at a thermostat setting of 235°F. At this setting, heating should continue until the water boils.
4. To shut down the unit, turn the thermostat dial to "OFF".



WARNING
WATER IS EXTREMELY HOT AND CAN CAUSE SEVERE BURNS. AVOID CONTACT WITH HOT WATER WHEN EMPTYING UNIT.

5. Pull the power tilt switch up to pour out the water and to confirm that the pan body can be tilted smoothly from horizontal to vertical.

If the unit functions as described above, it is ready for use. If it does not, contact your local Groen Authorized Service Agency.

Operation

A. Controls

Operator controls for the Braising Pans are:

1. The thermostat dial, located on the control console to the right of the pan body. This dial is used to turn the thermostat on or off and to set the thermostat for pan temperatures between 175° and 425°F.
2. The power tilt switch, located on the front of the cabinet, which is used to raise or lower the pan body.
3. The main supply gas valve, installed on the gas line to the unit.

4. For CHFP/1 and CHFP/2 only, the manual knob on the Combination Gas Control Valve, which is located under the pan on the gas line to the burner manifold. This valve selects settings of "OFF", "PILOT", or "ON" for the Combination Control. (See photograph on page 22).

B. Operating Procedure

WARNING
KEEP THE APPLIANCE AREA FREE AND CLEAR OF COMBUSTIBLE MATERIALS.

CAUTION
BE SURE ALL OPERATORS READ, UNDERSTAND AND FOLLOW THE OPERATING INSTRUCTIONS, CAUTIONS AND SAFETY INSTRUCTIONS CONTAINED IN THIS MANUAL.

KEEP FLOORS IN BRAISING PAN WORK AREA CLEAN AND DRY. IF SPILLS OCCUR, CLEAN IMMEDIATELY TO AVOID THE DANGER OF SLIPS OR FALLS.

OM-CHFP

1. For Models CHFP/1 and CHFP/2 with Standing Pilot Ignition

- a. To Start Pan
 - (1) Set thermostat to "OFF".
 - (2) Light gas pilot burner.
 - (a) Set knob on Combination Gas Control Valve to "OFF" by depressing the knob slightly and turning it clockwise.
 - (b) Turn the main supply gas valve ON (parallel to the gas pipe).
 - (c) Tilt the pan, so the pilot burner is easier to reach.
 - (d) Hold a lighted match at the pilot burner, while you depress the knob on the Combination Control and turn it counterclockwise to the "PILOT" position. Continue to hold the knob down for 60 seconds.
 - (e) Release the knob. The pilot flame should stay lighted.
 - (f) Turn the knob counterclockwise to "ON."
 - (3) Turn the thermostat dial to the desired temperature.

<p>CAUTION DO NOT HEAT AN EMPTY PAN FOR MORE THAN FIVE MINUTES AT A SETTING HIGHER THAN 300° F.</p>

- b. To Shut Off Pan
 - (1) Set the thermostat dial to "OFF".
 - (2) To turn off the gas pilot, depress the knob on the Combination Control and turn it clockwise to "OFF".
- c. To Relight Pilot
 - (1) Close the main supply gas valve.
 - (2) Set the thermostat to "OFF".
 - (3) Depress the knob on the Combination Control and turn it clockwise to "OFF".

- (4) Wait 5 minutes, then proceed as instructed at "To Start Pan" at left.

2. For Models CHFP/1/E and CHFP/2/E with Spark or Coil Ignition

- a. To Start Pan
 - (1) DO NOT attempt to light the burner with a flame.
 - (2) Turn on the electrical service to the unit.
 - (3) Turn the main supply gas valve ON (handle parallel to the gas pipe).
 - (4) Turn the thermostat dial to the desired temperature setting.
- b. To Turn Off Pan
 - (1) Set the thermostat to "OFF".
 - (2) For a prolonged shut-off period:
 - (a) Set the thermostat to "OFF".
 - (b) Turn the main gas valve OFF (handle at right angles to the gas pipe).
 - (c) Disconnect the electrical power.

3. To Tilt

- a. **Raise the cover.**
- b. Move the power tilt switch **up to raise** the pan, **down to lower** it. The switch will return to the OFF (middle) position when you release it.
- c. For models CHFP/2 and CHFP/2/E only, if the tilting mechanism stops working and the recommendations in "Troubleshooting," (page 13) don't work, you can tilt the pan body by hand:
 - 1) Fit the provided hand crank onto the slotted shaft end which protrudes from the actuator motor toward the front of the unit.
 - 2) Turn the crank clockwise to raise the pan body, and counterclockwise to lower it. It may take several minutes to crank the pan to the desired position.
 - 3) To speed the cranking operation,

you may use a reversible electric drill with a screwdriver bit.

operations, you may wish to close the vent to retain moisture.

WARNING
WHEN TILTING BRAISING PAN FOR PRODUCT TRANSFER:

- 1) USE CONTAINERS DEEP ENOUGH TO CONTAIN AND MINIMIZE PRODUCT SPLASHING.
- 2) PLACE CONTAINER ON A STABLE, FLAT SURFACE, AS CLOSE TO THE BRAISING PAN AS POSSIBLE.
- 3) STAND TO THE SIDE OF THE PAN WHILE POURING — NOT DIRECTLY IN THE POUR PATH OF HOT CONTENTS.
- 4) RETURN PAN BODY TO UPRIGHT POSITION AFTER CONTAINER IS FILLED OR TRANSFER IS COMPLETE.
- 5) DO NOT OVERFILL CONTAINER. AVOID DIRECT SKIN CONTACT WITH HOT CONTAINER AND CONTENTS.

4. To Preheat the Pan

- a. For best braising or frying results, preheat pan before you put in any food.
- b. To get an even temperature across the pan, preheat at a setting of 300°F or less for 15 minutes or through several on-off cycles of the burner.

CAUTION
DO NOT HEAT AN EMPTY PAN FOR MORE THAN FIVE MINUTES AT A SETTING HIGHER THAN 300°F. DAMAGE TO THE PAN COULD RESULT.

5. If Power Fails

- a. Do not try to operate the unit until power is restored.
- b. When power is restored, follow directions under “To Start Pan.”

c. Cooking

1. To simmer or slowly heat an item, set the dial at 210°F or lower. Put the cover down to minimize moisture loss, or leave it up to help dry or reduce the product. Set the thermostat higher to cook or drive off moisture faster. You may adjust the thermostat to any setting to cook the item exactly as required.
2. Leave the cover vent open to let excess steam escape. For long simmering



WARNING
STEAM CAN CAUSE BURNS. AVOID ESCAPING STEAM WHEN RAISING COVER.

3. To check progress when the cover is closed, lift the handle of the vent cover slightly, and move it quickly to either side.
4. Standing to one side of the pan (to avoid the steam that will be released) grasp the nearer corner of the cover handle and raise the cover. The cover will stay in the open position until you push it down.

WARNING
ITEMS IN SAUCE OR MELTED FAT CAN SLIDE FORWARD SUDDENLY DURING TILTING AND SPLASH THE HOT LIQUID.

4. To pour or dump product, remove grease, or assist cleaning, first raise the cover, then tilt the pan forward by pressing the tilt switch. When you release the switch, the pan body will hold its position.

OM-CHFP

Sequence of Operation

The following "action-reaction" outline is provided to help users understand how the equipment works.

A. Models CHFP/1 and CHFP/2

When the operator presses down the knob on the Combination Gas Control Valve and turns it to "Pilot," gas is admitted to the pilot burner. Depressing the knob in this position overrides the automatic control, which otherwise shuts off all gas supply when the thermopile is cold. Lighting and maintaining the pilot flame for 60 seconds heats the thermopile to operating temperature, so the thermopile begins to provide electric current at 750 millivolts. Electricity from the thermopile powers the control circuit and the Combination Gas Control Valve. When the thermopile begins operating at full capacity, the knob may be released.

When the knob is turned to "ON", the automatic valve for the main burner is able to open. Setting the thermostat to call for heat causes the thermostat to send a signal to the valve, which opens and admits gas to the main burner. Gas from the main burner is ignited by the pilot flame.

When the pan reaches the set temperature, the thermostat switch opens, stopping the signal to the main burner valve and causing the valve to close. When the pan cools below the set temperature, the thermostat switch closes and starts another heating cycle. On-off cycling continues and maintains the pan at the desired temperature.

B. Model CHFP/1/E with Spark Ignition

When the operator sets the desired temperature on the thermostat dial, the thermostat switch closes and sends a signal which (1) starts the spark and (2) opens the automatic valve for the pilot burner. The spark ignites the pilot flame, which is detected by the flame sensor probe. The probe then sends a signal to shut off the spark and open the automatic valve and admit gas to the main burner. The pilot flame ignites the main burner. If a pilot flame is not detected within 30 seconds after the spark starts, a lockout timer shuts down the whole operation.

When the pan reaches the set temperature, the thermostat switch opens, stopping the signal to the gas control valve and causing

the valve to close. When the pan cools below the set temperature, the thermostat switch closes and starts another heating cycle. On-off cycling continues and maintains the pan at the desired temperature.

C. Model CHFP/2/E with Coil Ignition

When the operator sets the desired temperature on the thermostat dial, the thermostat switch closes and causes electric current to heat the Carborundum glow coil. When the coil gets hot enough to ignite gas, a sensor built into the coil signals the automatic gas control valve, which admits gas to the burner. Gas flowing from the burner is ignited directly by the glow coil. A separate sensor detects flame at the burner and sends a signal that turns off electric power to the coil. If flame is not sensed within 30 seconds, a timer shuts off the gas flow.

When the pan reaches the set temperature, the thermostat switch opens, stopping the signal to the gas control valve and causing the valve to close. When the pan cools below the set temperature, the thermostat switch closes and starts another heating cycle. On-off cycling continues and maintains the pan at the desired temperature.

C. All Models

The thermostat controls heating by alternately calling for flames at the full capacity of the main burner and then signaling the control to shut the burner off completely. Because the control works in this "all or nothing" manner, the pan will heat as fast as it can until it reaches the set temperature, no matter what that temperature is. Turning the thermostat dial to a higher setting will cause heating to continue longer, until the pan reaches the higher temperature, but it cannot make the pan heat any faster.

The pans are protected from overheating by the high-limit thermostat. If the pan temperature rises above 425°F, the high-limit thermostat causes the automatic gas control valve to close. When the pan cools, the thermostat automatically resets and

permits normal operation to continue.

The power tilt switch controls a reversible motor which drives a ball screw mechanism. When the switch is held in the raised position, the mechanism raises the pan body. The body rests on trunnions near its front corners, so it tilts forward until the switch is released or the body reaches its vertical limit.

A tilt limit switch turns off gas flow to the burner so that the unit will not heat (operate) when the braising pan has been tilted 10° or more from horizontal.

If the tilting motor gets too hot during operation, an overheat protection switch will open and stop the motor. When the motor has cooled sufficiently, the switch will reset automatically and permit tilting to begin again. Such overheating will only occur if the pan is continuously tilted up and down through four or five cycles.

Cleaning

WARNING
KEEP WATER AND SOLUTIONS OUT OF CONTROLS AND BURNERS. NEVER SPRAY OR HOSE THE CONTROL CONSOLE OR ANY ELECTRICAL CONNECTIONS.

1. Before any cleaning operation, shut off the burner by turning the thermostat dial to "OFF". If water or cleaning solution will be sprayed, unplug the unit from the electric power source, or shut off the power at the circuit breaker or fuse panel.
2. Clean all food-contact surfaces soon after use, before the pan has cooled completely. If the unit is in continuous use, thoroughly clean and sanitize both interior and exterior at least once every 12 hours.
4. To remove materials stuck to the equipment, use a brush, sponge, cloth, plastic or rubber scraper, or plastic wool along with the detergent or soap solution. To minimize the effort required in washing, let the detergent solution sit in the pan and soak into the residue, or heat the detergent solution briefly in the pan. Do NOT use any abrasive materials or metal implement that might scratch the surface, because scratches make the pan hard to clean and provide places for bacteria to grow. Do NOT use steel wool, which may leave particles imbedded in the pan surface and cause eventual corrosion and pitting.



CAUTION
MOST CLEANERS ARE HARMFUL TO THE SKIN, EYES, MUCOUS MEMBRANES AND CLOTHING. PRECAUTIONS SHOULD BE TAKEN TO WEAR RUBBER GLOVES, GOGGLES OR FACE SHIELD AND PROTECTIVE CLOTHING. CAREFULLY READ THE WARNINGS AND FOLLOW THE DIRECTIONS ON THE LABEL OF THE CLEANER TO BE USED.

4. As part of the daily cleaning program, clean all external and internal surfaces that may have been soiled. Remember to check such parts as the underside of the cover, control console, etc.
 6. Controls and the control console may be cleaned with a damp cloth.
 7. The exterior surface of the unit may be polished with a recognized stainless steel cleaner, such as "Zepper" from Zep Manufacturing Co.
 8. If the equipment needs to be sanitized, use a sanitizing solution equivalent to one that supplies 200 parts per million available chlorine. Obtain advice on the best sanitizing
3. Scrape or rinse out large amounts of food residues, then wash the inside of the pan body with a mixture of hot water and soap or an appropriate detergent, such as Mikro-Quat from ECOLAB. Follow the detergent supplier's recommendations on strength of the solution. Rinse the pan thoroughly with hot water and drain completely.

OM-CHFP

agent from your supplier of sanitizing products. Following the supplier's instructions, apply the sanitizing agent after the unit has been cleaned and drained. Rinse off the sanitizer thoroughly.

NOTICE
NEVER LEAVE A CHLORINE SANITIZER IN CONTACT WITH STAINLESS STEEL SURFACES LONGER THAN 30 MINUTES. LONGER CONTACT CAN CAUSE CORROSION.

- 9. If there is difficulty removing mineral deposits or a film left by hard water or food residues, clean the pan thoroughly and then use a deliming agent, like Lime-Away from ECOLAB, in accordance with the manufacturer's directions. Rinse and drain the unit before further use.
- 10. If especially difficult cleaning problems persist, contact your cleaning product representative for assistance. The supplier has a trained technical staff with laboratory facilities to serve you.

Maintenance

Your Braising Pan is designed to require minimum maintenance, but certain parts may need replacement after prolonged use. After installation, no user adjustment should be necessary. If a service need arises, only authorized personnel should perform the work.



WARNING
ELECTRIC POWER ALWAYS SHOULD BE SHUT OFF BEFORE WORK IS DONE ON INTERNAL COMPONENTS.

Service personnel should check the unit at least once a year. This periodic maintenance should include inspecting electrical wires and connections, cleaning the inside of the control console, and possible adjustment of the pilot light.



Don't use metal implements or steel wool to clean the braising pan.



Use a brush, cloth, sponge or other non-abrasive tool for cleaning.



WARNING
DISCONNECT ELECTRICAL POWER FROM THE UNIT BEFORE ATTEMPTING TO GREASE THE TRUNNION BEARINGS.

A Service Log is provided with the warranty information at the back of this manual. Each time service is performed on your Groen equipment, enter the date on which the work was done, what was done, and who did it. Keep the manual with the equipment for quick and easy reference.

Troubleshooting

Your Groen Braising Pan will operate smoothly and efficiently if properly maintained. However, the following is a list of checks to make in the event of a problem. If the actions suggested do not solve the problem, call your qualified Groen Service Representative. For the phone number of the nearest agency, call your area Groen representative or the Groen Parts and Service Department. If an item on the list is followed by Y, the work should only be performed by a qualified service representative.

WARNING
BEFORE REPLACING ANY PARTS, DISCONNECT THE UNIT FROM THE ELECTRICAL POWER SUPPLY AND CLOSE THE MAIN GAS VALVE. ALLOW FIVE MINUTES FOR GAS TO VENT.

TO AVOID INJURY BY HOT CONTENTS, EMPTY THE PAN AND LET IT COOL BEFORE PERFORMING ANY WORK ON IT OR THE TILTING MECHANISM.

USE OF ANY REPLACEMENT PARTS OTHER THAN THOSE SUPPLIED BY GROEN OR THEIR AUTHORIZED DISTRIBUTORS CAN CAUSE INJURY TO THE OPERATOR AND DAMAGE TO THE EQUIPMENT AND WILL VOID ALL WARRANTIES.

Important: Service performed by other than factory authorized personnel will void all warranties.

SYMPTOM	WHO	WHAT TO CHECK
Y indicates items which must be performed by an authorized technician.		

A. All Models

Pan will not tilt.	User	a. That electric power is on. b. For overheated actuator motor. Wait 15 minutes for motor to cool, then operate power tilt.
Pan will not tilt after motor cools	Auth Service Rep Only	a. For burned out capacitor or motor.Y
Burners will not light	User	a. That the main gas supply valve is open (handle is in line with the gas pipe) b. Gas supply to the building. c. That the pan body is horizontal.
	Auth Service Rep Only	d. Thermostat operation.Y e. That the tilt limit switch is closed when the pan body is not tilted.Y
Pan continues to heat after it reaches desired temperature	User	a. Thermostat dial setting
	Auth Service Rep Only	b. Thermostat calibration.Y c. Thermostat operation.Y
Pan stops heating before reaching desired temperature.	User	a. Thermostat dial setting.
	Auth Service Rep Only	b. Thermostat calibration.Y c. Thermostat operation.Y
Pan heats unevenly	User	a. That the pan body is horizontal. b. That the pan is preheated properly in accordance with the instructions in the Operation section of this manual.

B. Models CHFP/1 and CHFP/2 with Standing Pilot Ignition

Pilot will not light.	User	a. Lighting procedure. Ensure that the instructions in the Operation section of this manual are followed
	Auth Service Rep Only	b. That the pilot gas supply line is purged of air.Y c. Pilot gas adjustment screw, to ensure that it is open.Y d. Pilot tubing and orifice for clogging.Y

OM-CHFP

Important: Service performed by other than factory authorized personnel will void all warranties.

SYMPTOM	WHO	WHAT TO CHECK Y indicates items which must be performed by an authorized technician.
---------	-----	---

B. Models CHFP/1 and CHFP/2 with Standing Pilot Ignition, Continued

Pilot flame goes out when Combination Control knob is released.	Auth Service Rep Only	a. Pilot gas adjustment.Y b. Are connections from Powerpile generator to Pilotstat power unit and Powerpile operator clean and secure?Y c. Are open and closed circuit output voltages of the generator in the acceptable range shown by the charts in the manual for the W720 Systems Tester?Y d. Resistance of the Pilotstat power unit.Y e. If an appropriate meter is not available, replace first the generator, then the power unit.Y
Pan will not heat, and pilot light is out	User	a. Is the Combination Gas Control Valve knob turned ON?
	Auth Service Rep Only	b. Check the pilot tubing and orifice for clogging.Y c. Are connections from Powerpile generator to Pilotstat power unit and Powerpile operator clean and secure?Y d. Are open and closed circuit output voltages of the generator in the acceptable range shown by the charts in the manual for the W720 Systems Tester?Y e. If an appropriate meter is not available, replace the generator.Y
Pan will not heat, but pilot light is burning.	Auth Service Rep Only	a. That high-limit thermostat switch is closed.Y

C. Model CHFP/1/E with Spark Ignition System (Refer to Schematic)

System does not produce a spark	Auth Service Rep Only	a. Thermostat and close the contacts, if they are open. b. AC voltage between terminals "2" and "GR." If it is not 24 Volt, take the following steps: (1) Check the high limit thermostat, which should be closed.Y (2) Replace the transformer.Y c. Pilot spark gap. Regap if it is not 7/64 inch.Y d. Electrode ceramic for crack or break.Y e. That the high tension cable is firmly attached and in good condition. If it is cracked or brittle, replace the pilot.Y f. Replace the electronic portion of the G60 system.Y
Spark is present, but the pilot will not light.	Auth Service Rep Only	a. That the pilot valve is securely connected to terminals "1" and "GR." (Valve models have the pilot grounded internally).Y b. That gas pressure meets the control manufacturer's specifications.Y c. For gas at the pilot. If it is not flowing, take the following steps: (1) Check the pilot gas line for kinks and obstructions.Y (2) Replace the pilot valves.Y d. That the pilot spark gap is 7/64 inch and located in the pilot gas stream. If not, adjust or replace the pilot.Y e. Orifice. Clean if necessary.Y f. For drafts. Shield the pilot burner, if necessary.Y

Important: Service performed by other than factory authorized personnel will void all warranties.

SYMPTOM	WHO	WHAT TO CHECK
Y indicates items which must be performed by an authorized technician.		
C. Model CHFP/1/E with Spark Ignition System (Refer to Schematic), Continued		
Pilot lights, but main burner will not come on, and spark stays on.	Auth Service Rep Only	<ul style="list-style-type: none"> a. Sensor cable, to ensure secure attachment to terminal "4" on G60 and to the sensor.Y b. Sensor ceramic for cracks.Y c. That cable is not grounded out. If it is, correct the ground.Y d. Sensor cable for continuity and insulation condition.Y e. That sensor probe current is greater than 0.7 microamp. Y (Disconnect sensor wire from terminal "4." Connect a DC microammeter between the sensor wire terminal and terminal "4"). If the current equals or exceeds 0.7 microamp, replace the G60 electronics.Y If the current is less: <ul style="list-style-type: none"> (1) Check the gas pressure and clean the pilot assembly. Y (2) Tighten mechanical and electrical connections.Y f. Pilot application and correct to increase sensor probe current by: <ul style="list-style-type: none"> (1) Increasing or decreasing pilot orifice size. Y (2) Shielding the pilot from drafts.Y
Pilot lights, but the main burner will not come on and the spark does not stay on.	Auth Service Rep Only	<ul style="list-style-type: none"> a. For 24 Volts between terminals "3" and "GR." If voltage is incorrect, replace the G60 electronics.Y b. Than gas pressure meets control manufacturer specifications.Y c. Electrical connections of the main valve to terminals "3" and "GR," to assure that they are securely attached. If they are, replace the main valve.Y

D. Model CHFP/2/E with Coil Ignition System (Refer to Schematic)

Burner does not come on, and glow coil does not heat.	User	a. That electric power is being supplied to the unit.
	Auth Service Rep Only	<ul style="list-style-type: none"> b. For 115V input to the control module.Y c. For a 24V supply at the transformer.Y d. For 24V between pins "2" and "4" of the control module. If not present, check the thermostat/high-limit circuit for open thermostat switches .Y e. Voltage supply to the igniter. Remove the igniter plug from the control module receptacle and read voltage across the igniter receptacle pins. If 115V is present, replace the igniter. If 115V is not present, replace the control module.Y f. Voltage across the terminals of the main gas valve solenoid. If 24 VAC is present, replace the gas valve assembly. If not, replace the control module.Y
Burner does not come on, but the glow coil heats.	User	a. That gas is being supplied to the unit.
	Auth Service Rep Only	<ul style="list-style-type: none"> b. Voltage across the terminals of the gas valve solenoids. If 24 VAC is present, replace the gas valve assembly. If not, replace the control module.Y c. Ground connection of module terminal "12" (green wire) for firm attachment.Y d. Flame sensing probe and wire "11" (blue) for a short to ground. If found, correct the short or replace the probe.Y e. For a short to ground at 24V source. If the transformer is shorted, correct the short and replace the control module.Y f. After the transformer has been replaced, check the flame sensing function. If flame sensing is not working, reverse the 115V or 24V leads on the control transformer side.Y

OM-CHFP

Parts List - CHFP/1 & CHFP/1E Models

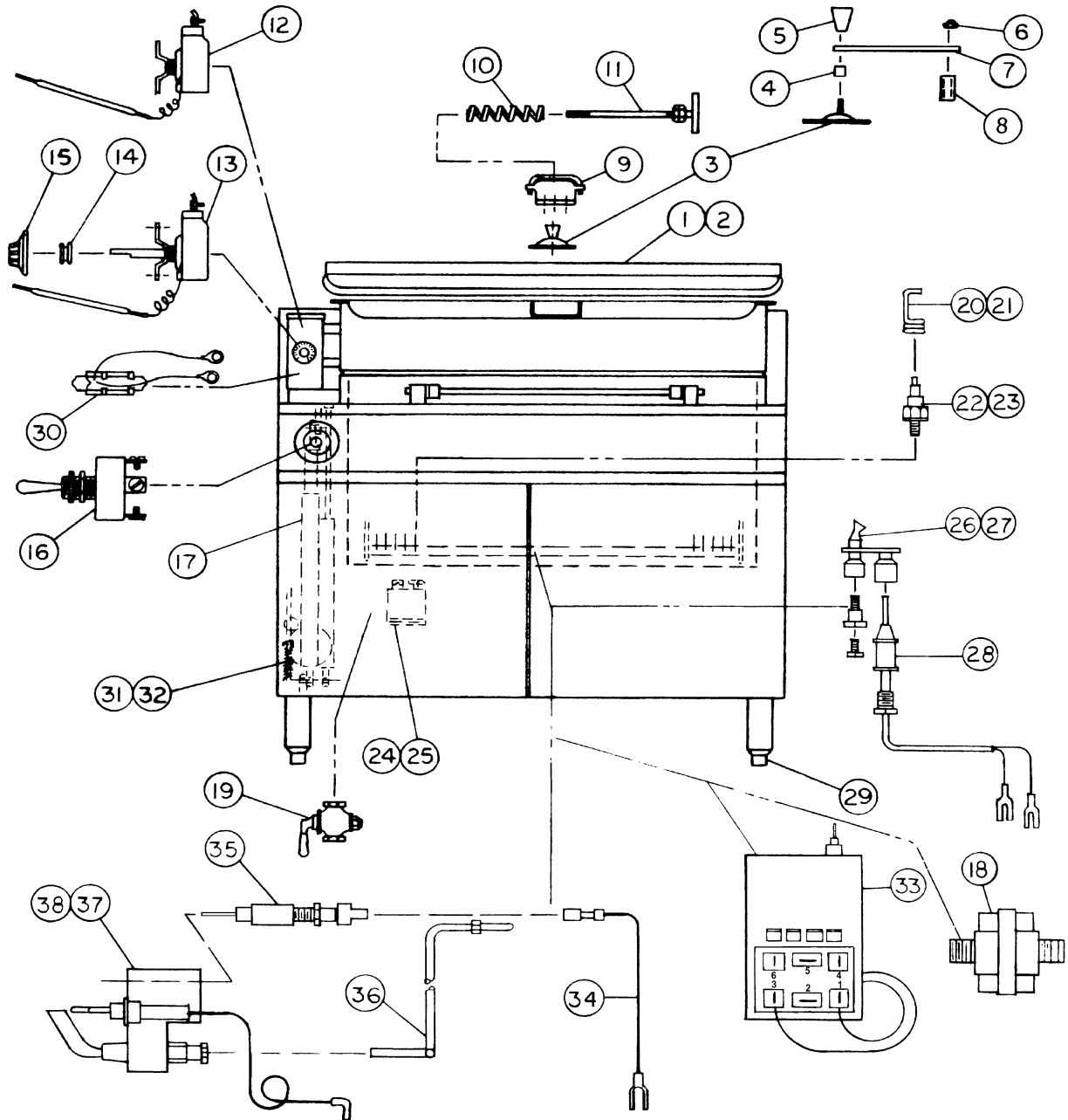

Parts List - CHFP/1 & CHFP/1E Models

To order parts, contact your authorized Groen Service Agency. Supply the model designation, part description, part number, quantity, and where applicable, voltage and phase.

Key	Description	Part No.	Key	Description	Part No.
1	Cover Assembly, Size 3 Pan	014031	20	Flame Spreader, Natural Gas	013489
2	Cover Assembly. Size 4 Pan	104032	21	Flame Spreader, Propane Gas	014391
3	Cover, Vent	003265	22	Burner Tip, Natural Gas	001133
4	Spacer, Shortg Front	002378	23	Burner Tip, Propane Gas	017765
5	Knob, Plastic	002408	24	Valve, Natural Gas Control	002648
6	Nut, Dome	005471	25	Valve, Propane Gas Control	002649
7	Arm for Vent Cover	002377	26	Burner, Pilot, Natural Gas	001125
8	Spacer. Long Rear	012733	27	Burner, Pilot, Propane Gas	001129
9	Actuator, Cover	014085	28	Thermopile	001126
10	Spring	012533	29	Foot, Bullet	013275
11	Rod Assembly, Spring	012524	30	Switch, Mercury, with clip	007517
12	Thermostat, High Limit	013481	31	Spring	003316
13	Thermostat, Adjustable	041700	32	Clamp	007870
14	Grommet, Rubber	001518	33	Control, Electronic (spark ignition)	079801
15	Knob, Thermostat	003908	34	Lead, Probe, 30 inch	003329
16	Switch, Momentary Toggle	002664	35	Probe, Pilot Flame Sensing	003328
17	Actuator, Tilting - Size 3 Pan	002655	36	Tubing	—
	Actuator vert. tilt - Size 4 Pan	N/A	37	Burner, Pilot, Natural Gas	003325
	Actuator Horiz. tilt - Size 4 Pan	N/A	38	Burner, Pilot, Propane Gas	003326
18	Transformer	074839	39	Regulator, Gas Pressure	054326
19	Valve, Manual Gas	008172			

OM-CHFP

Parts List - CHFP/2 & CHFP/2E Models

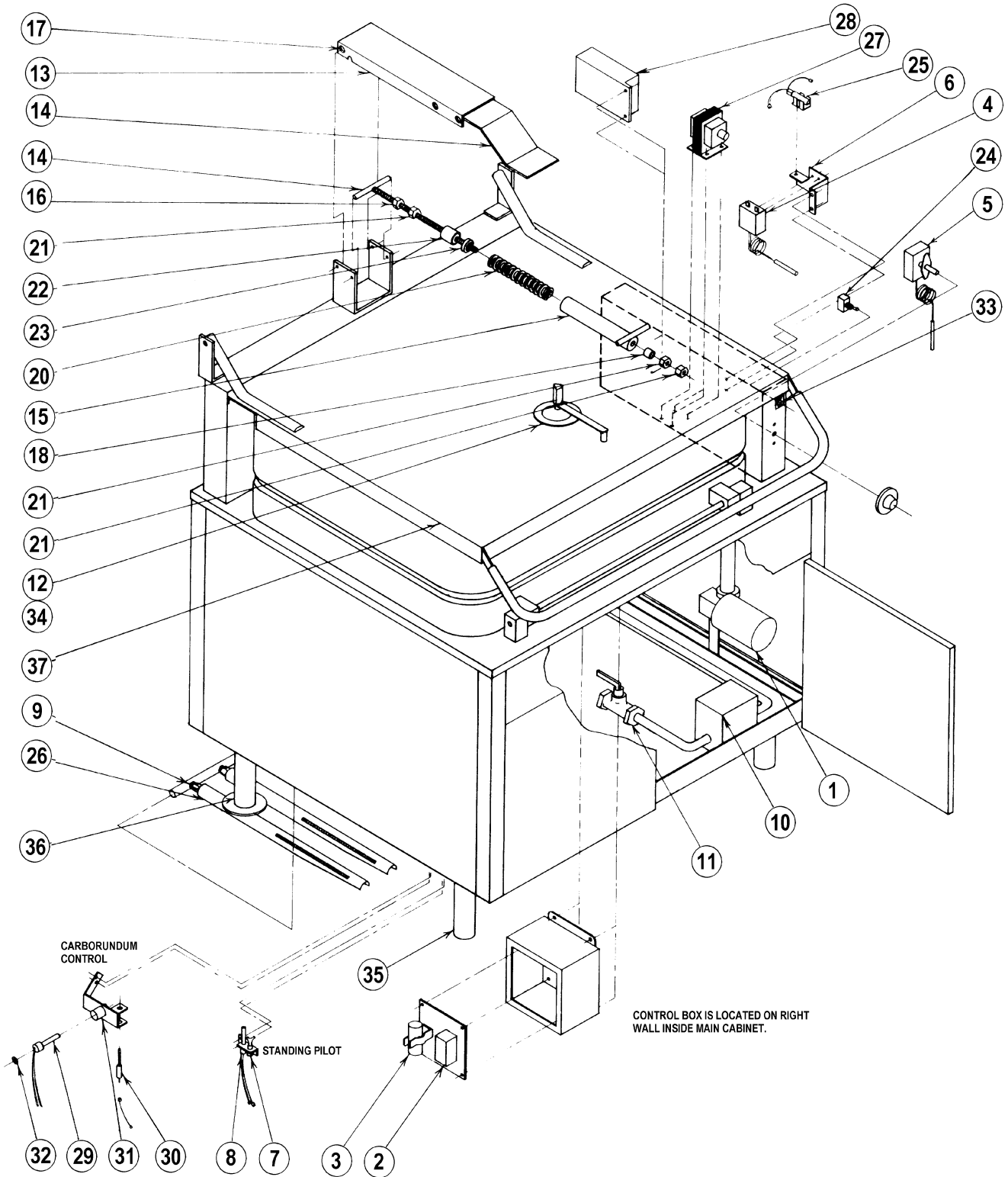

Parts List - CHFP/2 & CHFP/2E Models

To order parts, contact your authorized Groen Service Agency. Supply the model designation, part description, part number, quantity, and where applicable, voltage and phase.

Key	Description	Part No.	Key	Description	Part No.
1	Actuator, Tilting, Size 3 Pan	045880	18	Spacer, Front	012528
	Actuator, Tilting, Size 4 Pan	083667	19	Ring external, retaining (not shown)	012529
2	Block, Terminal	043128	20	Spring, High Pressure	012533
3	Capacitor, 18 : fd	050384	21	Nut, Hex jam, ½-13	012538
4	Thermostat, High Limit	013481	22	Spacer, reare	012814
5	Thermostat, Adjustable	041700	23	Washer, Plain	005598
6	Bracket, Thermostat	005068	24	Switch, Momentary Toggle, Size 3	002664
7	Pilot Burner, Natural Gas	001125		Switch, Momentary Toggle, Size 4	003500
	Pilot Burner, Propane Gas	001129	25	Switch, Mercury	007517
8	Thermopile	001126	26	Burner	051619
9	Orifice, Natural Gas	045897	27	Transformer (Coil ignition only)	003331
	Orifice, Propane Gas	050047	28	Control, Gas ignition (Coil ignit only)	076519
10	Valve Natural Gas Ctrl (Stdg Pilot)	002648	29	Igniter, Coil	054285
	Valve Propane Gas Ctrl (Stdg Pilot)	002649	30	Probe, Sensing, with Kanthol	003328
	Valve Essex Natural Gas Ctrl (Coil)	081711	31	Bracket, Coil Mounting	066013
	Valve Essex Propane Ctrl (Coil)	081712	32	Cotter Pin	012947
11	Valve, Manual Gas	005429	33	Label, Raise - Lower	051471
12	Vent Assembly, Cover	017494	34	Knob, Plastic	002408
13	Body, Cover Actuator	002440	35	Leg Assembly with bullet foot	003597
14	Bracket, Cover	013277	36	Leg Assembly with flanged base	003598
15	Housing Assembly, Spring	012407	37	Cover & Handle Assembly Size 3	048798
16	Rod Assembly, Spring	012524		Cover & Handle Assembly Size 4	046450
17	Pin, Actuator Hinge	012525			

Electrical Schematics - CHFP/1

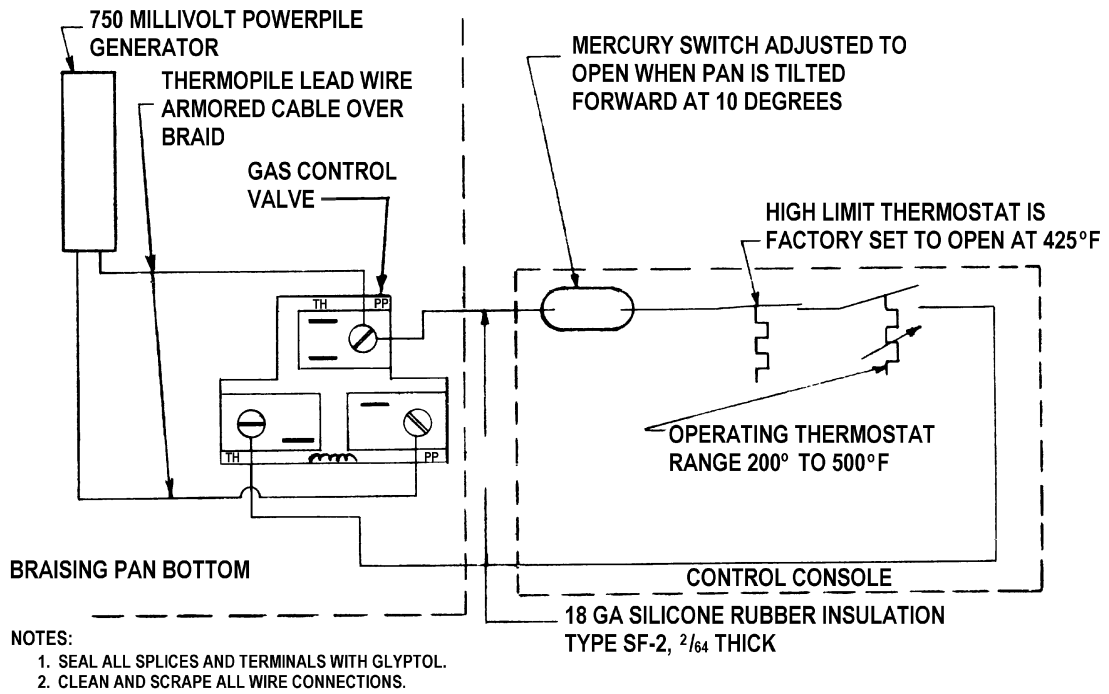

Standing Pilot - Natural Gas & Propane

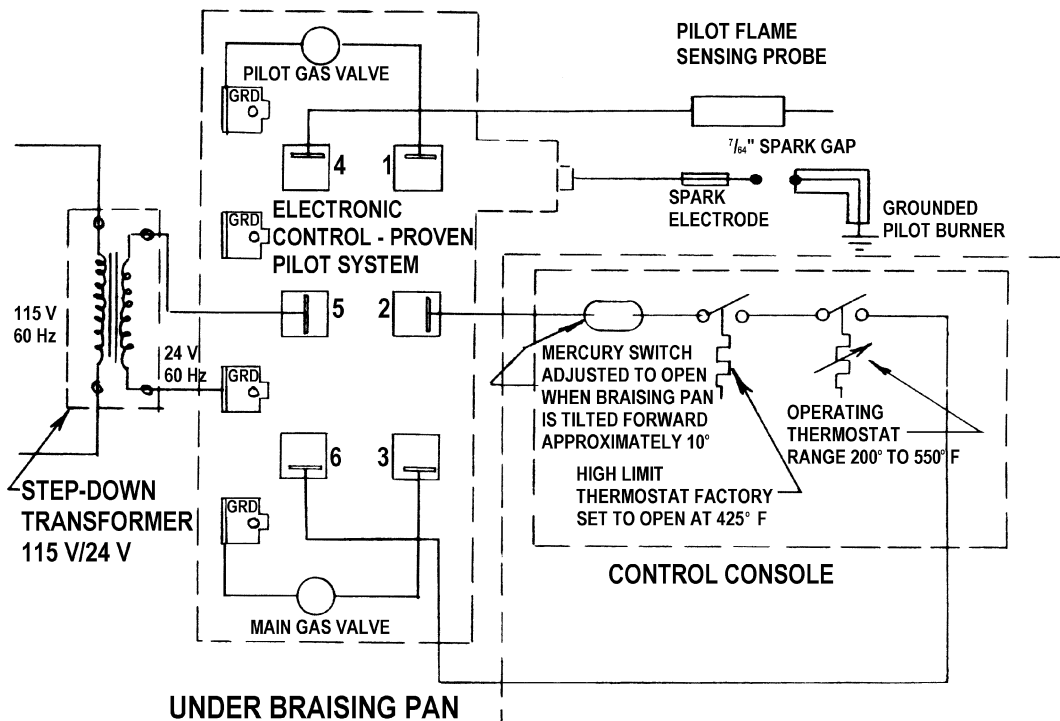

Spark Ignition - Natural Gas

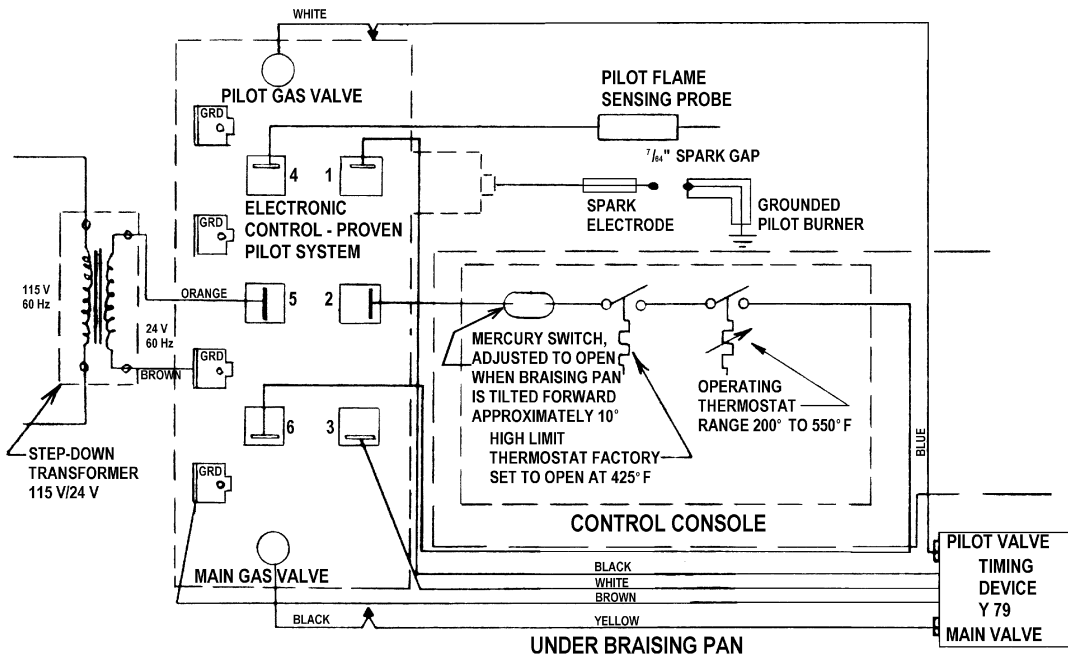

Spark Ignition - Propane

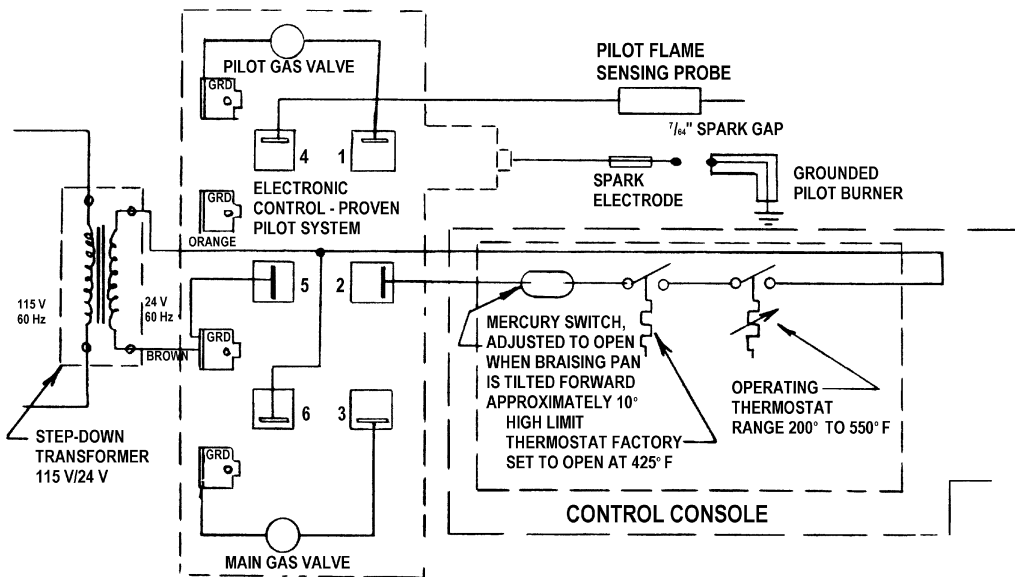

G60QHL-1 Ignition - Natural Gas and Propane

OM-CHFP

Combination Gas Control Valve

Selector Knob

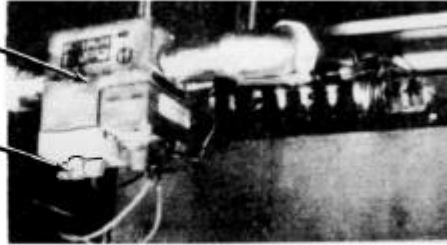

Control for Standing Pilot Ignition

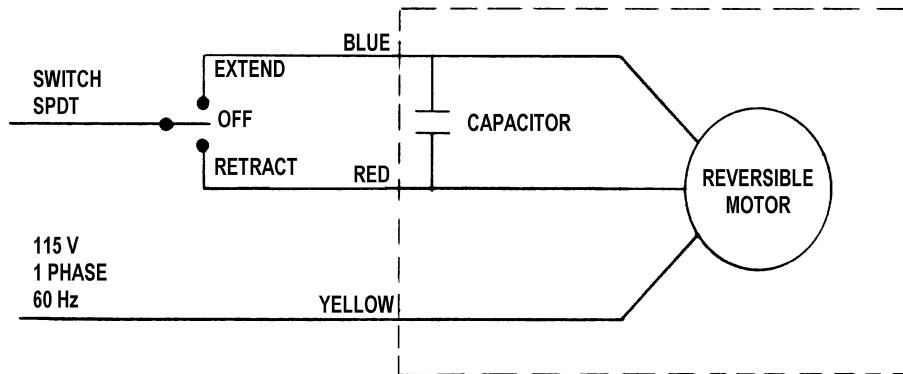

Tilting Actuator, Duff-Norton

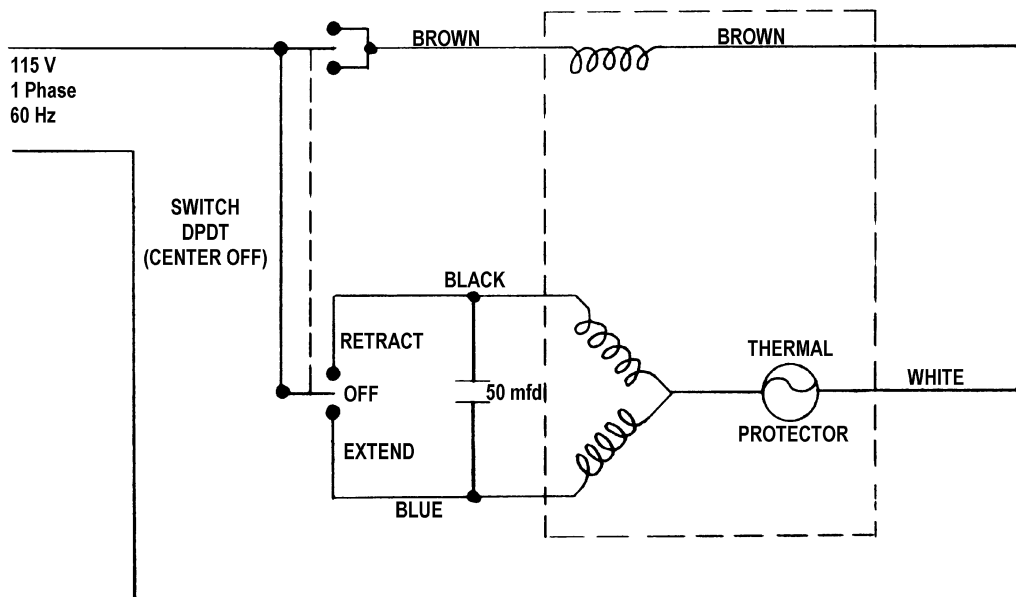

Tilting Actuator, Warner

CHFP/2 Wiring Schematics

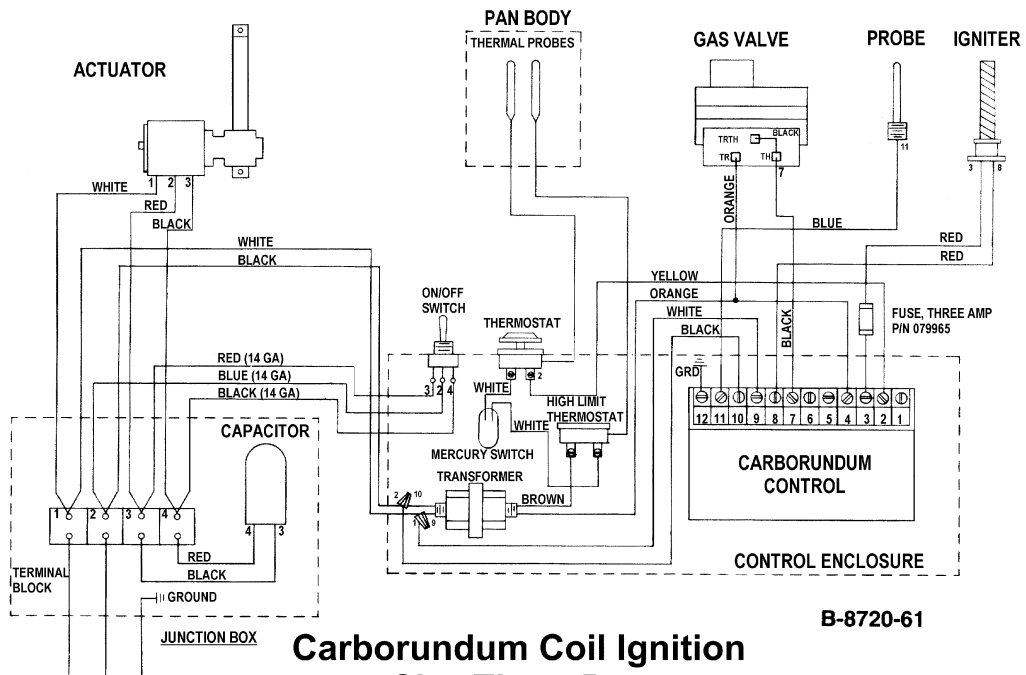

**Carborundum Coil Ignition
Size Three Pan**

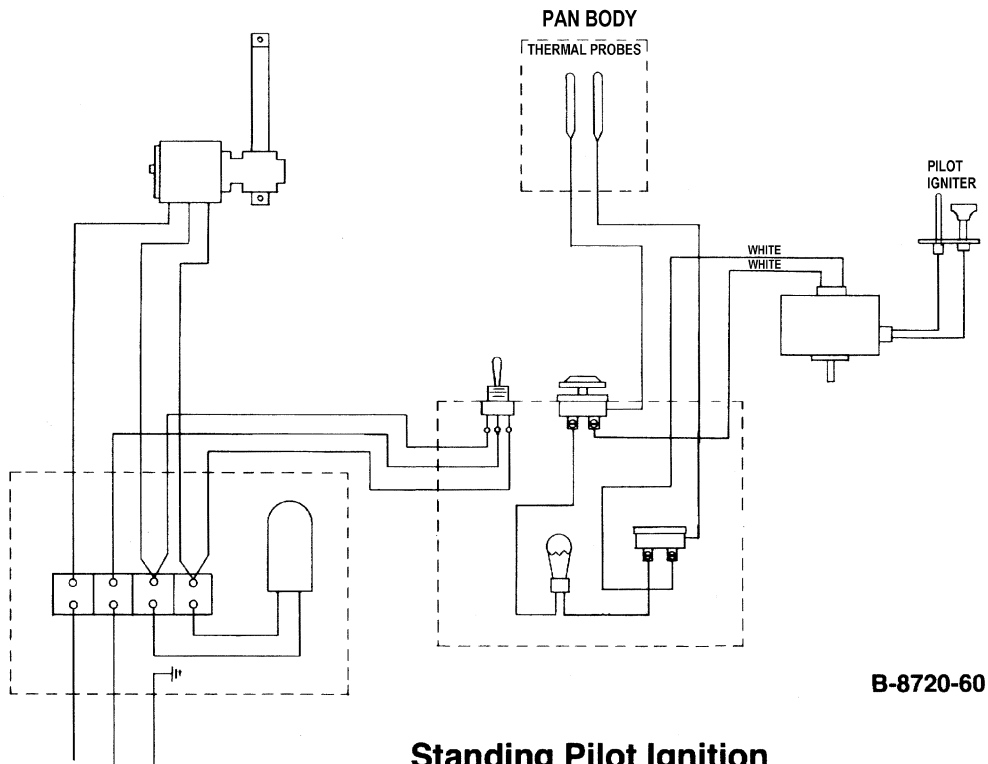

**Standing Pilot Ignition
Size 3 Pan**

Wiring Diagrams (Cont'd)

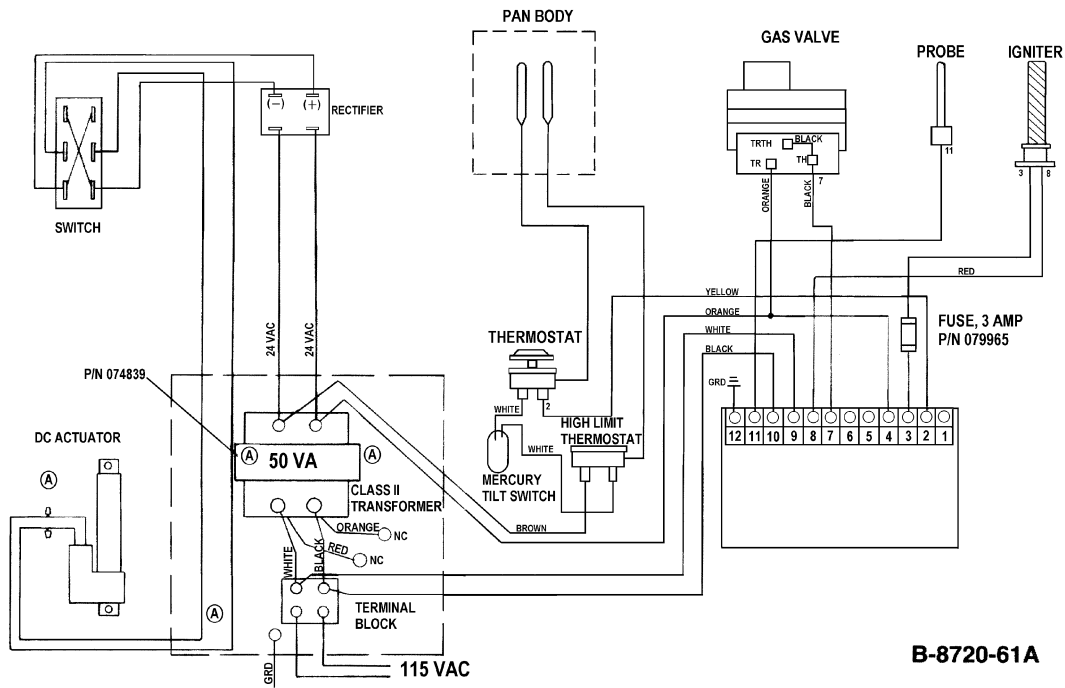

B-8720-61A

Carborundum Coil Ignition
Size 4 Pan

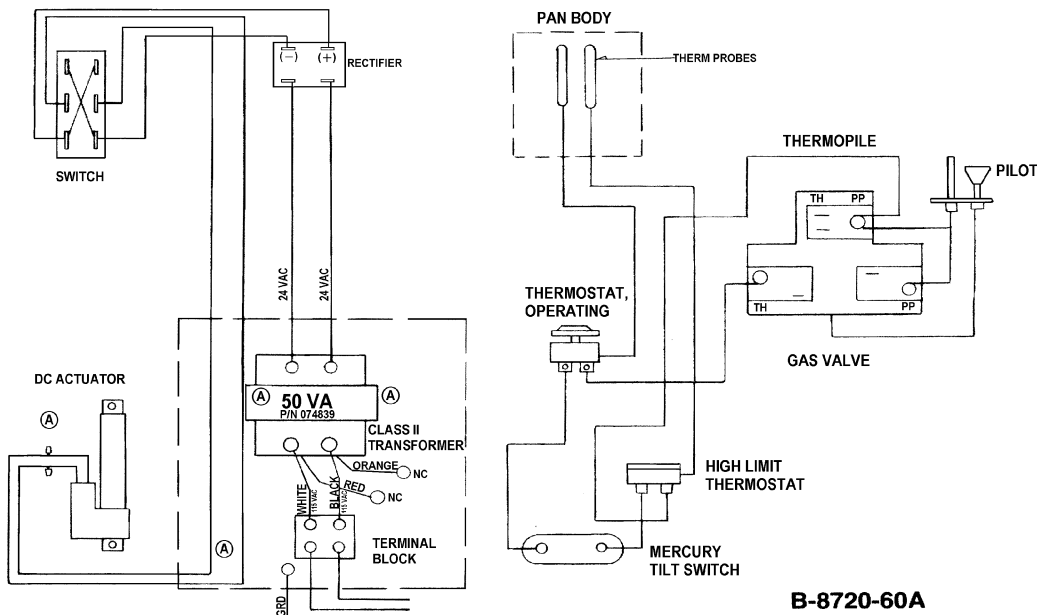

B-8720-60A

Standing Pilot Ignition
Size 4 Pan

References

AMERICAN NATIONAL STANDARDS INSTITUTE
1403 Broadway
New York, New York 10018

Z21.30 Installation of Gas Appliances & Piping
Z223.1 1984 National Fuel Gas Code

AMERICAN GAS ASSOCIATION LABORATORIES
8501 East Pleasant Valley Road
Cleveland, Ohio 44131

KLENZADE SALES CENTER
ECOLAB, Inc.
370 Wabasha
St. Paul, Minnesota 55102
800 328-3663

NATIONAL FIRE PROTECTION ASSOCIATION
60 Battery March Park
Quincy, Massachusetts 02269

NFPA/54 Installation of Gas Appliances & Piping
NFPA/70 The National Electric Code

NATIONAL SANITATION FOUNDATION
3475 Plymouth Road
Ann Arbor, Michigan 48106

ZEP MANUFACTURING
1390 Lunt Avenue
Elk Grove Village, Illinois 60007

Limited Warranty To Commercial Purchasers *

(Domestic U.S., Hawaii &
Canadian Sales Only)

Groen Foodservice Equipment ("Groen Equipment") has been skillfully manufactured, carefully inspected and packaged to meet rigid standards of excellence. Groen warrants its Equipment to be free from defects in material and workmanship for (12) twelve months with the following conditions and subject to the following limitations.

- I. This parts and labor warranty is limited to Groen Equipment sold to the original commercial purchaser/users (but not original equipment manufacturers), at its original place of installation in the continental United States, Hawaii and Canada.
- II. Damage during shipment is to be reported to the carrier, is not covered under this warranty, and is the sole responsibility of purchaser/user.
- III. Groen, or an authorized service representative, will repair or replace, at Groen's sole election, any Groen Equipment, including but not limited to, draw-off valves, safety valves, gas and electric components, found to be defective during the warranty period. As to warranty service in the territory described above, Groen will absorb labor and portal to portal transportation costs (time & mileage) for the first twelve (12) months from date of installation or fifteen (15) months from date of shipment from Groen.
- IV. This warranty does not cover boiler maintenance, calibration, periodic adjustments as specified in operating instructions or manuals, and consumable parts such as scraper blades, gaskets, packing, etc., or labor costs incurred for removal of adjacent equipment or objects to gain access to Groen Equipment. This warranty does not cover defects caused by improper installation, abuse, careless operation, or improper maintenance of equipment. This warranty does not cover damage caused by poor water quality or improper boiler maintenance.
- V. **THIS WARRANTY IS EXCLUSIVE AND IS IN LIEU OF ALL OTHER WARRANTIES, EXPRESSED OR IMPLIED, INCLUDING ANY IMPLIED WARRANTY OF MERCHANTABILITY OR FITNESS FOR A PARTICULAR PURPOSE, EACH OF WHICH IS HEREBY EXPRESSLY DISCLAIMED. THE REMEDIES DESCRIBED ABOVE ARE EXCLUSIVE AND IN NO EVENT SHALL GROEN BE LIABLE FOR SPECIAL, CONSEQUENTIAL OR INCIDENTAL DAMAGES FOR THE BREACH OR DELAY IN PERFORMANCE OF THIS WARRANTY.**
- VI. Groen Equipment is for commercial use only. If sold as a component of another (O.E.M.) manufacturer's equipment, or if used as a consumer product, such Equipment is sold AS IS and without any warranty.

* (Covers All Foodservice Equipment Ordered After October 1, 1995)



1055 Mendell Davis Drive
Jackson, MS 39212
Telephone 601 372-3903
FAX 601 373-9587

OM-CHFP (Revised 10/98)
Part Number 121031