



OPERATOR MANUAL

IMPORTANT INFORMATION, KEEP FOR OPERATOR

888-994-7636, fax 888-864-7636
unifiedbrands.net

THIS MANUAL MUST BE RETAINED FOR FUTURE REFERENCE. READ, UNDERSTAND AND FOLLOW THE INSTRUCTIONS AND WARNINGS CONTAINED IN THIS MANUAL.

FOR YOUR SAFETY Instructions to be followed in the event user smells gas. This information shall be obtained by consulting your local gas supplier. As a minimum, turn off the gas and call your gas company and your authorized service agent. Evacuate all personnel from the area.

WARNING Improper installation, adjustment, alteration, service or maintenance can cause property damage, injury or death. Read the installation, operating and maintenance instructions thoroughly before installing or servicing this equipment.

NOTIFY CARRIER OF DAMAGE AT ONCE It is the responsibility of the consignee to inspect the container upon receipt of same and to determine the possibility of any damage, including concealed damage. Groen suggests that if you are suspicious of damage to make a notation on the delivery receipt. It will be the responsibility of the consignee to file a claim with the carrier. We recommend that you do so at once.

Manufacture Service/Questions 888-994-7636.

This manual provides information for:

LOW HEIGHT STEAM JACKETED KETTLE WITH STANDARD ELECTRONIC IGNITION MODELS DHS(/T)-40(C,A,C2T™)

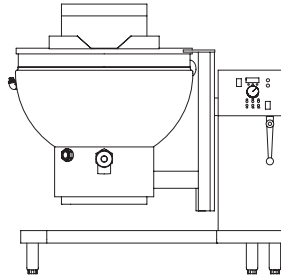

REFERENCES

CSA INTERNATIONAL
8501 East Pleasant Valley Road
Cleveland, Ohio 44131

NSF INTERNATIONAL
798 N. Dixboro Rd.
P.O. Box 130140
Ann Arbor, Michigan 48113-0140

UNDERWRITERS LABORATORIES, INC.
333 Pflugsten Road
Northbrook, Illinois 60062

KLENZADE SALES CENTER ECOLAB, Inc.
370 Wabasha
St. Paul, Minnesota 55102

NATIONAL FIRE PROTECTION ASSOCIATION
60 Battery March Park
Quincy, Massachusetts 02269

ZEP MANUFACTURING COMPANY
1310-T Seaboard Industrial Boulevard
Atlanta, Georgia 30318

AMERICAN NATIONAL STANDARDS INST., INC.
1430 Broadway
New York, New York 10018

ICC – INTERNATIONAL CODE COUNCIL
500 New Jersey Avenue, NW
6th Floor, Washington, DC 2000

EQUIPMENT DESCRIPTION

The Groen DHS is a floor-mounted, tilting, steam jacketed kettle with an electronically controlled, self-contained, gas-heated steam source and appropriate controls, mounted on a sturdy base. The Model DHS is currently only available in a 40 gallon capacity.

The body of the DHS Kettle is constructed of stainless steel, welded into one solid piece. The kettle is furnished with a reinforced rim and a butterfly shaped pouring lip. It has a steam jacket which is ASME shop inspected and registered with the national board for working pressures up to 50 PSI. Kettle finish is 180 emery grit on the inside and bright high buff polish on the outside.

The kettle is tilted with a hand crank to pour out its contents. Stainless steel panels enclose the controls and the base. A u-shaped frame with four stainless steel tubular legs support the unit. Bullet feet on each of the legs can be adjusted to level the kettle. Models with a "T" suffix are supplied with a two-inch tangent draw-off valve.

The self-contained steam source is heated by propane or natural gas. Electronic spark to pilot ignition is standard for all units.

The kettle is filled at the factory with water which contains rust inhibitors. The steam source provides kettle temperatures of 150° to approximately 295°F (65 to 150°C). Unit controls include a temperature controller, pressure gauge, safety valve, pressure limit control, low water cut-off, power switch and gas regulator valve. The gas burner shuts off automatically when the kettle is tilted.

The unit must be specified for use with natural or propane gas. Service connections for gas and electricity are required. Standard power supply is 120 VAC.

Options available include:

1. Two inch tangent drawoff*
2. Strainers, solid disk (P/N 013783), 1/4" (P/N 009044) or 1/8" perforations (P/N 013875)
3. No. 31 lift-off cover (P/N 004282)
4. No. 51 counterbalanced cover w/actuator* (P/N 148287)
5. Basket Inserts (Tri-BC) (P/N 140527)
6. Water fill faucets with swing spout
7. Kettle Brush Kit (P/N 104278)
8. Gallon or Liter etch marks (factory installed)
9. Automatic, metered water filler



Information contained in this document is known to be current and accurate at the time of printing/creation. Reference our product line website for the most updated product information and specifications. © 2023 Electrolux Professional, Inc. All Rights Reserved.

IMPORTANT - READ FIRST - IMPORTANT

- WARNING:** FAILURE TO DISCONNECT POWER BEFORE SERVICING COULD RESULT IN ELECTROCUTION AND DEATH.
- WARNING:** IMPROPER INSTALLATION, ADJUSTMENT, ALTERATION, SERVICE OR MAINTENANCE CAN CAUSE PROPERTY DAMAGE, INJURY OR DEATH. READ THE INSTALLATION, OPERATING AND MAINTENANCE INSTRUCTIONS THOROUGHLY BEFORE INSTALLING OR SERVICING THIS EQUIPMENT.
- WARNING:** THE UNIT MUST BE INSTALLED BY PERSONNEL QUALIFIED TO WORK WITH GAS, ELECTRICITY AND PLUMBING. UNIT MUST BE INSTALLED IN ACCORDANCE WITH ALL APPLICABLE CODES.
- WARNING:** DO NOT ATTACH THE UNIT TO A TYPE "B" VENT. IT COULD CAUSE FIRE OR PROPERTY DAMAGE.
- WARNING:** DO NOT CONNECT ANY PIPING TO THE PRESSURE RELIEF VALVE. IT MUST BE FREE TO VENT STEAM AS NEEDED. TO AVOID BURNS FROM THE VENTED STEAM THE VALVE DISCHARGE SHOULD POINT DOWNWARD. IMPROPER INSTALLATION WILL VOID WARRANTY.
- DANGER:** ELECTRICALLY GROUND THE UNIT AT THE TERMINAL PROVIDED. FAILURE TO GROUND THE UNIT COULD RESULT IN ELECTROCUTION AND DEATH.
- CAUTION:** BE SURE ALL OPERATORS READ, UNDERSTAND AND FOLLOW THE OPERATING INSTRUCTIONS, CAUTIONS AND SAFETY INSTRUCTIONS CONTAINED IN THIS MANUAL.
- CAUTION:** DO NOT OVERFILL THE KETTLE WHEN COOKING, HOLDING OR CLEANING. KEEP LIQUIDS A MINIMUM OF 2-3" (5-8 CM) BELOW THE KETTLE BODY RIM TO ALLOW CLEARANCE FOR STIRRING, BOILING AND SAFE TRANSFER OF PRODUCT.
- CAUTION:** KEEP FLOORS IN FRONT OF KETTLE WORK AREA CLEAN AND DRY. IF SPILLS OCCUR, CLEAN IMMEDIATELY TO AVOID SLIPS OR FALLS.
- WARNING:** KEEP WATER AND SOLUTIONS OUT OF CONTROLS AND BURNERS. NEVER USE A HIGH PRESSURE HOSE TO CLEAN KETTLE SURFACES.
- CAUTION:** MOST CLEANERS ARE HARMFUL TO THE SKIN, EYES, MUCOUS MEMBRANES AND CLOTHING. TAKE PRECAUTIONS: WEAR RUBBER GLOVES, GOGGLES OR FACE SHIELD AND PROTECTIVE CLOTHING. CAREFULLY READ WARNINGS AND FOLLOW DIRECTIONS ON CLEANER LABELS .
- WARNING:** DO NOT STAND ON OR APPLY UNNECESSARY WEIGHT OR PRESSURE ON THE KETTLE FRONT OR POURING LIP. THIS COULD RESULT IN THE OVERLOAD AND FAILURE OF THE TILT MECHANISM, AND POSSIBLE SERIOUS INJURY AND BURNS TO THE OPERATOR AND OTHERS.
- NOTICE:** NEVER LEAVE A SANITIZER IN CONTACT WITH STAINLESS STEEL SURFACES LONGER THAN 10 MINUTES. LONGER CONTACT CAN CAUSE CORROSION.
- WARNING:** FAILURE TO PERIODICALLY CHECK PRESSURE RELIEF VALVE OPERATION COULD RESULT IN PERSONAL INJURY AND/OR DAMAGE TO EQUIPMENT.

- WARNING:** WHEN TESTING, AVOID EXPOSURE TO THE STEAM BLOWING OUT OF THE PRESSURE RELIEF VALVE. DIRECT CONTACT COULD RESULT IN SEVERE BURNS.
- WARNING:** TO AVOID INJURY, READ AND FOLLOW ALL PRECAUTIONS STATED ON THE LABEL OF THE WATER TREATMENT COMPOUND.
- WARNING:** BEFORE REPLACING ANY PARTS, DISCONNECT THE UNIT FROM THE ELECTRIC POWER SUPPLY AND CLOSE THE MAIN GAS VALVE. ALLOW 5 MINUTES FOR GAS TO VENT.
- CAUTION:** USE OF ANY REPLACEMENT PARTS OTHER THAN THOSE SUPPLIED BY GROEN OR AUTHORIZED DISTRIBUTORS CAN CAUSE INJURY TO THE OPERATOR AND DAMAGE TO THE EQUIPMENT AND WILL VOID ALL WARRANTIES.
- WARNING:** KEEP AREA AROUND KETTLE FREE AND CLEAR OF ALL COMBUSTIBLE MATERIALS. FAILURE TO DO SO COULD RESULT IN FIRE OR PROPERTY DAMAGE.
- CAUTION:** HEATING AN EMPTY KETTLE MAY CAUSE THE RELEASE OF STEAM FROM THE PRESSURE RELIEF VALVE.
- IMPORTANT:** SERVICE PERFORMED BY OTHER THAN FACTORY AUTHORIZED PERSONNEL WILL VOID ALL WARRANTIES.
- WARNING:** THIS UNIT IS INTENDED FOR USE IN THE COMMERCIAL HEATING, COOKING AND HOLDING OF WATER AND FOOD PRODUCTS, PER THE INSTRUCTIONS CONTAINED IN THIS MANUAL. ANY OTHER USE COULD RESULT IN SERIOUS PERSONAL INJURY OR DAMAGE TO THE EQUIPMENT AND WILL VOID WARRANTY.
- WARNING:** AVOID ALL DIRECT CONTACT WITH HOT EQUIPMENT SURFACES. DIRECT SKIN CONTACT COULD RESULT IN SEVERE BURNS.
- WARNING:** AVOID ALL DIRECT CONTACT WITH HOT FOOD OR WATER IN THE KETTLE. DIRECT CONTACT COULD RESULT IN SEVERE BURNS.
- WARNING:** WHEN TILTING KETTLE FOR PRODUCT TRANSFER:
- 1) USE CONTAINER DEEP ENOUGH TO CONTAIN AND MINIMIZE SPLASHING.
 - 2) PLACE CONTAINER ON STABLE, FLAT SURFACE, AS CLOSE TO KETTLE AS POSSIBLE.
 - 3) DO NOT OVER FILL CONTAINER. AVOID DIRECT SKIN CONTACT WITH HOT CONTAINER AND ITS CONTENTS.
- WARNING:** DO NOT HEAT AN EMPTY KETTLE. EXCESSIVE STEAM PRESSURE COULD DEVELOP.
- NOTICE:** IT IS RECOMMENDED THAT AN INSTANT-READ THERMOMETER BE USED TO CHECK THE INTERNAL TEMPERATURE THROUGHOUT THE COOKING PROCESS AND AFTER THE COOKING PROCESS HAS BEEN COMPLETED TO ENSURE THE FOOD HAS BEEN COOKED SUFFICIENTLY.

PERFORMANCE DATA

Model	Kettle Capacity	Tangent Draw-Off	Jacket Capacity	Kettle Body Diameter	Base Width	Base Front to Back	Firing Rate Per Hour	Energy into Product Per Hour
DHS-40 (C,A,C2T)	40 Gal.	No	14 Gal.	30 in.	47 in.	29 in.	150,000 BTU	82,000 BTU
	150 liter		53 liter	762 mm	1194 mm	736 mm		
DHS/T-40 (C,A,C2T)	40 Gal.	Yes	14 Gal.	30 in.	47 in.	29 in.	150,000 BTU	82,000 BTU
	150 liter		53 liter	762 mm	1194 mm	736 mm		

INSPECTION & UNPACKING

CAUTION: SHIPPING STRAPS ARE UNDER TENSION AND CAN SNAP BACK WHEN CUT. TAKE CARE TO AVOID PERSONAL INJURY OR DAMAGE TO THE UNIT BY STAPLES LEFT IN THE WALLS OF THE CARTON.

CAUTION: THIS UNIT WEIGHS BETWEEN 535 AND 978 POUNDS (245 TO 400 KG) DEPENDING ON SIZE. INSTALLER SHOULD USE PROPER EQUIPMENT TO LIFT SAFELY.

The unit will arrive bolted or banded to a skid. Immediately upon receipt, inspect the unit carefully for exterior damage. Carefully remove the crating around the unit. Thoroughly inspect the unit for hidden damage. Report any shipping damage or incorrect shipments to the delivery agent.

Write down the model number, serial number, and installation date, and retain this information for future reference. Space for these entries is provided at the top of the Service Log at the back of this manual. Keep this manual on file and available for operators to use.

When installation is to begin, carefully cut any straps which hold the unit on the skid. Lift the unit straight up off the skid. Examine packing materials to be sure loose parts are not discarded with the materials.

INSTALLATION

WARNING: THE UNIT MUST BE INSTALLED BY PERSONNEL WHO ARE QUALIFIED TO WORK WITH GAS, ELECTRICITY AND PLUMBING. IMPROPER INSTALLATION CAN CAUSE INJURY TO PERSONNEL AND/OR DAMAGE TO THE EQUIPMENT. THE UNIT MUST BE INSTALLED IN ACCORDANCE WITH APPLICABLE CODES. THE UNIT MUST BE INSTALLED BY A LICENSED PLUMBER OR GAS FITTER WHEN INSTALLED WITHIN THE COMMONWEALTH OF MASSACHUSETTS.

DANGER: ELECTRICALLY GROUND THE UNIT AT THE TERMINAL PROVIDED. FAILURE TO GROUND UNIT COULD RESULT IN ELECTROCUTION AND DEATH.

WARNING: DO NOT CONNECT ANY PIPING TO THE PRESSURE RELIEF VALVE. THE VALVE MUST BE FREE TO VENT STEAM AS NEEDED. IMPROPER INSTALLATION WILL VOID THE WARRANTY! THE ELBOW ATTACHED TO THE PRESSURE RELIEF VALVE MUST POINT TO THE FLOOR.

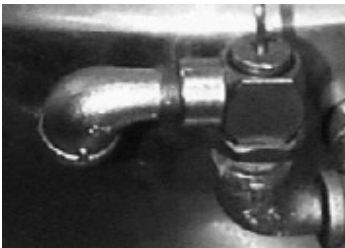

The open end of the pressure relief valve elbow must face downward.



When attaching the draw-off valve, hand-tighten the nut.

For efficient performance the kettle must be installed in a well-ventilated area. Items which might restrict or obstruct the flow of air for combustion and ventilation must be removed. The area directly around the appliance must be free of combustible materials.

1. Installation can be on a combustible or noncombustible floor. Clearances should be per table.

	MINIMUM CLEARANCE FROM COMBUSTIBLE WALLS	MINIMUM CLEARANCE FROM NON-COMBUSTIBLE WALLS	RECOMMENDED CLEARANCES
Left Side	6 in.	0 in.	6 in.
Right Side	6 in.	0 in.	10 in.
Rear	10 in.	10 in.	12 in.

2. The kettle should be installed in an adequately ventilated room with provision for adequate air supply. The ventilation must employ a vent hood and exhaust fan with no direct connection between the vent duct and the kettle flue. Do not obstruct the flue or vent duct after installation.
3. Set the kettle in place and level it using a spirit level on the bar rim, by turning the bullet or flange feet to adjust leg length. Allow clearance around the unit for cleaning, maintenance and service.
4. Complete the piping to the gas service main with ½" line or approved equivalent.
5. For standard units, provide 115 vac, 60 Hz, single phase 5 AMP electrical service. Observe local codes and/or The National Electrical Code in accordance with ANSI/NFPA 70 (current edition), or the Canadian Electrical Code, CSA C22.2 (current edition), as applicable. Use the wiring diagram inside the service panel and at the rear of this manual.
6. Core probe storage bracket (C2T models only)
 - a. It is recommend that the core probe storage bracket be installed on the control console. It is not recommend that the core probe storage bracket be installed on the kettle body or cover.
 - b. To obtain proper adhesion, the bonding surface must be unified, clean and dry. Clean the bonding surface with rubbing alcohol and allow the surface to dry. Next firmly apply pressure to the storage bracket to help improve bond strength. After application, the bond strength will increase as the adhesive flows onto the surface. At room temperature, approximately 50% of the ultimate strength will be achieved after 20 minutes, 90% after 24 hours and 100% after 72 hours.

7. Bring electrical service through the entrance at the rear of the support housing with a ½ inch conduit connector. Make a watertight connection with the incoming lines.
8. Electrically ground the unit at the terminal provided.
9. After the kettle has been connected to the gas supply, check all gas joints for leaks. DO NOT USE FLAME TO CHECK FOR LEAKS. A thick soap solution or other suitable leak detector should be employed.
10. The gas supply and unit's installation must conform with local codes or in the absence of local codes, with the National Fuel Gas Code, ANSI Z223.1/NFPA 54 (current edition), or the Natural Gas and Propane Installation Code CSA 149.1(current edition), as applicable. Additionally following must be complied with: THE AREA DIRECTLY AROUND THE APPLIANCE MUST BE CLEARED OF ALL COMBUSTIBLE MATERIAL. FAILURE TO FOLLOW THESE INSTRUCTIONS CAN CAUSE BODILY INJURY AND /OR PROPERTY DAMAGE. The appliance and its individual shut-off valve must be disconnected from the gas supply piping system during any testing at pressures in excess of ½ PSI (3.45 kPa). The appliance must be isolated from the gas supply piping system by closing its individual manual shut-off valve during any pressure testing at or less than ½ PSI (3.45 kPa).
11. Confirm that the jacket water level is between the gauge glass markers or inside the sight glass port. If the level is low, follow instructions under Jacket Filling and Water Treatment in this manual.
12. The open end of the elbow on the outlet of the safety valve must face downward. If it does not, turn it to the correct position.
13. For units with optional tangent draw-off: Assemble the tangent draw-off by placing the large nut over the draw-off valve and inserting it into the draw-off tube. ONLY HAND-TIGHTEN THE NUT to complete installation.

INITIAL START-UP

WARNING: WATER IS EXTREMELY HOT AND CAN CAUSE SEVERE BURNS. AVOID CONTACT WITH HOT WATER WHEN EMPTYING UNIT.

WARNING: DO NOT STAND ON OR APPLY UNNECESSARY WEIGHT OR PRESSURE ON THE KETTLE FRONT OR POURING LIP. THIS COULD RESULT IN THE OVERLOAD AND FAILURE OF THE TILT MECHANISM, AND POSSIBLE SERIOUS INJURY AND BURNS TO THE OPERATOR AND OTHERS.

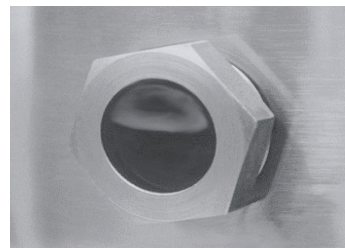

Correct water level.

After the kettle has been installed, the installer should test to ensure that it is operating correctly.

1. Remove literature and packing materials from the interior and exterior of the unit.
2. If the unit is equipped with a draw-off valve (product outlet), clean out any material which might clog or damage the draw-off.
3. Confirm that the tilting mechanism is operating properly by tilting the kettle through its full range. Then return the kettle to the upright position.
4. Turn on the electrical service to the unit.
5. Pour 1-2 gallons of water into the kettle.
6. Following "To Start Kettle" instructions in the "Operation" section in this manual, begin heating the water at the highest controller setting. The heat indicator light should come on, and heating should continue until the water boils.

If the kettle functions as described, it is ready for use. If the unit does not operate as designed, contact an authorized Service Agent.

OPERATION

WARNING: WHEN TILTING KETTLE:

- 1) WEAR PROTECTIVE OVEN MITT AND PROTECTIVE APRON.
- 2) USE DEEP CONTAINER TO CONTAIN AND MINIMIZE PRODUCT SPLASHING.
- 3) PLACE CONTAINER ON STABLE, FLAT SURFACE, AS CLOSE TO KETTLE AS POSSIBLE.
- 4) STAND TO RIGHT OF KETTLE WHILE POURING — NOT DIRECTLY IN POUR PATH OF HOT CONTENTS.
- 5) POUR SLOWLY, MAINTAINING CONTROL OF KETTLE, AND RETURN KETTLE BODY TO UPRIGHT POSITION AFTER CONTAINER IS FILLED OR TRANSFER IS COMPLETE.
- 6) DO NOT OVERFILL CONTAINER. AVOID SKIN CONTACT WITH HOT CONTAINER AND ITS CONTENTS.

WARNING: AVOID ALL DIRECT CONTACT WITH HOT SURFACES AND HOT FOOD OR WATER IN THE KETTLE. DIRECT CONTACT COULD RESULT IN SEVERE BURNS.

CAUTION: DO NOT OVERFILL THE KETTLE WHEN COOKING, HOLDING OR CLEANING. KEEP LIQUIDS AT LEAST 2-3" (5-8 CM) BELOW THE KETTLE RIM TO ALLOW CLEARANCE FOR STIRRING, BOILING AND SAFE PRODUCT TRANSFER.

WARNING: AVOID ALL DIRECT CONTACT WITH HOT FOOD OR WATER IN THE KETTLE. DIRECT CONTACT COULD RESULT IN SEVERE BURNS.

CAUTION: HEATING AN EMPTY KETTLE MAY CAUSE THE RELEASE OF STEAM FROM THE PRESSURE RELIEF VALVE.

CAUTION: DO NOT TILT KETTLE BODY WITH COVER OR BASKET INSERT IN PLACE. COVER MAY SLIDE OFF, CAUSING INJURY TO OPERATOR.

CAUTION: ANY POTENTIAL USER OF THE EQUIPMENT MUST BE TRAINED IN SAFE AND CORRECT OPERATING PROCEDURES.

WARNING: KEEP AREA AROUND KETTLE FREE AND CLEAR OF ALL COMBUSTIBLE MATERIALS. DO NOT ATTEMPT TO LIGHT ANY BURNER WITH A FLAME.



Classic Control

Advanced Control

Cook2Temp Control

CONTROLS

1. Classic Control (-C) Models

- a. The manual gas shut-off valve supplies inlet gas to the unit.
- b. Lighted Power ON switch located on the control console. Controls main power to the unit.
- c. The temperature knob, located on the control console, is used to set the kettle heat values between 1 and 10.
- d. Heating indicator light located on the control console, lights when the controller sends call to open the main gas valve and will cycle on and off once the unit reaches set temperature. If the unit is tilted, the main gas valve will be disabled and the light will turn off until the unit is returned to the cooking position.
- e. A LOW WATER indicator light, located on the control console, illuminates when the jacket water falls below acceptable levels. When lit, the main gas valve is disabled and will not function until the jacket water is refilled using the procedure in this manual.

- f. Crank tilt – a handle controls the worm and gear mechanism that smoothly tilts the kettle body and holds it in the desired position.

2. Advanced Control (-A) Models

- a. The manual gas shut-off valve supplies inlet gas to the unit.
- b. Lighted Power ON switch located on the control console. Controls main power to the unit.
- c. The temperature knob, located on the control console, is used to set the kettle heat values between 1.0 and 10.0. The current setting will be reflected on the display.
- d. Heating indicator light located on the control console, lights when the controller sends call to open the main gas valve and will cycle on and off once the unit reaches set temperature. If the unit is tilted, the main gas valve will be disabled and the light will turn off until the unit is returned to the cooking position.
- e. A LOW WATER indicator light, located on the control console, illuminates when the jacket water falls below acceptable levels. When lit, the main gas valve is disabled and will not function until the jacket water is refilled using the procedure in this manual.
- f. SET TnP Mode - Allows power to the controller and gas to the pilot without the kettle heating; the kettle will heat once the LOW TEMP, MANUAL or HIGH TEMP button is selected.
- g. LOW TEMP Button – Used to set operating temperature of the kettle at a preset low intensity (default = 2.0). Can be pressed at any time during operation of the unit to change the set temperature to the preset value except when there is an active TIMER enabled.
- h. MANUAL Mode button – Enables the user modify the desired cooking temperature of the kettle (between 1.0 and 10.0) using the temperature knob and display (default = 5.0). The operator will press the MANUAL button and set the desired temperature using the temperature knob and display. Once the desired intensity is displayed, the user may either press the MANUAL button again or wait 5 seconds and the set temperature will be accepted by the controller and locked in. After the set temperature is accepted, it may be changed at any time by pressing the MANUAL button and resetting the temperature using the same process above.
- i. HIGH TEMP button – Used to set operating temperature of the kettle at a preset high intensity (default = 7.0). Can be pressed at any time during operation of the unit to change the set temperature to the preset value except when there is an active TIMER enabled.
 1. TIMER button - once the appropriate set temperature is selected using the HIGH TEMP, MANUAL or LOW TEMP buttons; a countdown timer can be set to remind the user when the cooking process is completed. Range – 1 minute to 10 hours
 2. When the timer expires:
 - a. the set temperature will automatically change to the LOW TEMP setting and will continue at this setting until the user changes the temperature via MANUAL or HIGH TEMP buttons
 - b. An audible alarm will notify the user that attention is required, the alarm will continue to sound until the user presses the TIMER button.
 3. An active timer can be cancelled by pressing and holding the TIMER button for 5 secs.
 4. Set temp can be changed during an active timer by pressing the MANUAL button and adjusting the set temp using the Temperature knob and display.
 5. HIGH TEMP and LOW TEMP presets cannot be used to change the setpoint once a TIMER has started.
- j. READY alarm – The control will sound 3 beeps when the unit has reached within 20 degrees of set point during pre-heat and when a higher set temperature is selected.

- k. Crank tilt – a handle controls the worm and gear mechanism that smoothly tilts the kettle body and holds it in the desired position.

3. Cook2Temp™ Control (-C2T™) Models

- a. Lighted Power ON switch located on the control console. Controls main power to the unit.
- b. Heating indicator light located on the control console, lights when the controller calls for the main gas valve to open and will cycle on and off once the unit reaches set temperature. If the unit is tilted, the call for heat will be interrupted and the light will turn off until the unit is returned to the cooking position.
- c. Low Water indicator light, located on the control console, lights when the jacket water falls below the acceptable levels. When lit, the main gas valve is disabled and will not function until the jacket water is refilled using the procedure in the operator manual.
- d. Set Mode – Allows power to the controller and the pilot to light, but the main burners remain off. The kettle will heat once the LOW TEMP, MANUAL or HIGH TEMP button is selected.
- e. LOW TEMP Button – Used to set a unit temperature of the kettle at a preset low temperature (default = 175°F). Can be pressed at any time during operation of the unit to change the unit temperature to the preset value except when there is an active TIMER or an active Cook2Temp.
- f. MANUAL Button – Enables the user to modify the unit temperature of the kettle (between 100°F and 287°F) using the temperature knob and display (default = 183°F). The operator will press the MANUAL button and then select the desired unit temperature using the temperature knob and display. Once the desired unit temperature is shown on the display, the user may either press the MANUAL button again or wait 5 seconds and the selected temperature will be accepted by the controller and locked in. After the selected temperature is accepted it may be changed at any time by pressing the MANUAL button and resetting the temperature using the same process as above except when there is an active AUTO Cook2Temp.
- g. HIGH TEMP Button – Used to set unit temperature of the kettle at a preset high temperature (default = 287°F). Can be pressed at any time during operation of the unit to change the unit temperature to the preset value except when there is an active TIMER or an active Cook2Temp.
- h. TIMER Button – Once the appropriate unit temperature is selected using the LOW TEMP, MANUAL or HIGH TEMP buttons, a countdown timer can be set to remind the user when the cooking process is completed.
 - 1. Range – 1 minute to 10 hours.
 - 2. When the timer expires:
 - a. The unit temperature will automatically change to the LOW TEMP setting and will continue at this setting until the user changes the temperature via MANUAL or HIGH TEMP buttons.
 - b. An audible alarm will notify the user that attention is required, the alarm will continue to sound until the user presses the TIMER button.
 - 3. An active timer can be cancelled by pressing and holding the TIMER button for 5 seconds.
 - 4. Unit temperature can be changed during an active timer by pressing the MANUAL button and adjusting the unit temperature using the temperature knob and display.
 - 5. LOW TEMP and HIGH TEMP presets cannot be used to change the unit temperature once a TIMER has been enabled.
 - 6. AUTO C2T and MANUAL C2T cannot be used once a timer has been enabled. The timer must first be cancelled and then AUTO C2T or MANUAL C2T can be enabled.
- i. Ready alarm – The control will sound 3 beeps when the unit has reached within 20 degrees of set point during pre-heat and when a higher unit temperature is selected.

- j. AUTO C2T Button – Enables the user to select a set product temperature (between 100°F and 230°F) using the temperature knob and display. The operator will press the AUTO C2T button and then select the set product temperature using the temperature knob and display. Once the set product temperature is shown on the display, the user may either press the AUTO C2T button again or wait 5 seconds and the selected temperature will be accepted by the controller and locked in. The unit temperature is automatically set 100°F above the set product temperature and cannot be changed at any time during an active AUTO C2T. After the set product temperature is accepted it may be changed at any time by first cancelling AUTO C2T and then using the same process as above to reset the temperature.
 - 1. After the set product temperature is accepted by the controller and locked in. The unit will begin to heat and the display will scroll the actual product temperature followed by the set product temperature. This display will continue until the cook process has completed.
 - 2. An active AUTO C2T can be cancelled by pressing and holding the AUTO C2T button for 5 seconds and the unit will then return to Set Mode.
 - 3. LOW TEMP, MANUAL or HIGH TEMP presets cannot be used to change the unit temperature once there is an active AUTO C2T. The unit temperature is automatically set by the controller.
 - 4. Once the set product temperature has been reached and held for 20 seconds consecutively the unit will automatically enable Hold Mode.
- k. MANUAL C2T Button – Enables the user to select a set product temperature (between 100°F and 230°F) using the temperature knob and display. The operator will press the MANUAL C2T button and then select the set product temperature using the temperature knob and display. Once the set product temperature is shown on the display, the user may either press the MANUAL C2T button again or wait 5 seconds and the selected temperature will be accepted by the controller and locked in. Once the set product temperature has been accepted the user will be prompted to select a unit temperature via the MANUAL button. Once the set unit temperature is shown on the display, the user may either press the MANUAL C2T button again or wait 5 seconds and the selected temperature will be accepted by the controller and locked in. After the set product temperature and unit temperature are accepted the set product temperature may be changed at any time by first cancelling MANUAL C2T and then using the same process as above to reset the temperature.
 - 1. After the set product temperature and unit temperature are accepted by the controller and locked in. The unit will begin to heat and the display will scroll the actual product temperature followed by the set product temperature. This display will continue until the cook process has completed.
 - 2. An active MANUAL C2T can be cancelled by pressing and holding the MANUAL C2T button for 5 seconds and the unit will then return to Set Mode.
 - 3. Unit temperature can be changed during an active MANUAL C2T by pressing the MANUAL button and adjusting the unit temperature using the temperature knob and display.
 - 4. Once the set product temperature has been reached and held for 20 seconds consecutively the unit will automatically enable Hold Mode.
- l. Hold Mode – Allows the unit to be controlled by the set product temperature and core probe.
 - 1. Hold Mode is automatically enabled once a set product temperature has been reached and held for 20 seconds consecutively.
 - 2. The display will scroll the actual product temperature followed by the hold timer.
 - 3. If the actual product temperature falls below 142°F.
 - a. An audible alarm along with the display flashing the actual

product temperature will notify the user that attention is required.

- b. The alarm can be silenced by pressing any button.
 - c. The Alarm will resound every 10 minutes until the actual product temperature returns above 142°F.
4. If the actual product temperature rises 10°F above the set product temperature.
- a. An audible alarm along with the display flashing the actual product temperature will notify the user that attention is required.
 - b. The alarm can be silenced pressing any button.
 - c. The alarm will resound every 10 minutes until the actual product temperature returns to within 10°F of the set product temperature.
5. At initial hold timer completion (default = 4 hours).
- a. An audible alarm will be given for 5 seconds.
 - b. The alarm can be silenced by pressing any button.
 - c. The alarm will continue to resound every 15 minutes until Hold Mode is exited.
- m. Display Descriptions
1. SET nndE – Allows power to the controller without the pan heating, the pan will heat once the LOW TEMP, MANUAL or HIGH TEMP button is selected.
 2. SET PrOd tEnP – Indicates the desired finished product temperature.
 3. SET UnIt tEnP – Indicates the desired unit temperature.
 4. SET POInt – Indicates the set point for the desired finished product temperature.
 5. ACT – Indicates the actual product temperature.
 6. CPeR – Indicates a core probe error and will continue to display until the error has been resolved.
 7. Prob – Indicates a unit probe error and will continue to display until the error has been resolved.
 8. End – Indicates the cooking process has completed.
 9. End HOld – Indicates the initial hold timer has completed.

4. Cook2Temp™ Control (-C2T™) Core Probe

- a. Ensure the core probe has been properly cleaned and sanitized before each use.
- b. It is important that the tip of the core probe be placed correctly into the product since only the tip of the core probe senses the product temperature. Do this by inserting the core probe halfway into the product, positioning the tip at the center of the food mass, avoiding any bones. If placing into a semi-liquid or liquid product, occasionally stirring the product will ensure an accurate core probe reading. Do not let the core probe tip touch the edges, bottom or side of the unit.
- c. If the core probe is not plugged into the receptacle when either the AUTO C2T or MANUAL C2T button is pressed then an audible alarm along with a core probe error message will notify the user that attention is required. Simply plug the core probe into the receptacle and continue with the input process.
- d. If the core probe is unplugged from the receptacle during the cooking process or while in Hold Mode an audible alarm along with a core probe error message will notify the user that attention is required. Simply plug the core probe back into the receptacle and the cook process or Hold Mode will continue.
- e. While the core probe is not in use ensure the sealing cap is properly protecting the panel mount connector. Failure to properly use the sealing cap could result in damage to the unit.

OPERATING PROCEDURE

1. To Start Kettle Heating:
 - a. EVERY DAY make sure that the jacket water level in the middle of the sight glass. If the level is too low, see “Jacket Filling and Water Treatment” in this manual.
 - b. Check the pressure/vacuum gauge. If the gauge does not show 20 to 30 inches of mercury (Hg) vacuum (that is a reading of 20 to 30 below 0 atmospheric pressure), see “Jacket Vacuum” in this manual.
 - c. DO NOT attempt to light any burner with a flame.
 - d. Open the main supply gas valve (handle in line with the pipe).
 - e. Turn the switch to ON.
 - f. Set heat using instructions above.
2. To Stop Kettle Heating:
 - a. Turn the switch OFF.
 - b. Turn the manual gas valve OFF (handle a right angle to gas line).
 - c. Disconnect the units electrical power.
3. To Relight Kettle:
 - a. Close main gas supply valve.
 - b. Set on-off switch to OFF.
 - c. Wait five minutes, then proceed as directed under To Start Kettle Heating.
4. If electric power fails, do not attempt to operate the unit. When power is restored, proceed as directed in To Start Kettle Heating.
5. To Transfer Product or Empty Kettle:
 - a. To tilt the body of the kettle forward, turn the hand crank on the front of the cabinet counter-clockwise. The body will stay in the position it holds when you stop cranking. To return the kettle body to its upright position, turn the crank clockwise.
 - b. Product may also be transferred by means of the optional draw-off valve, if the kettle is so equipped.

USE OF COMMON ACCESSORIES

1. Lift-Off or Counterbalanced Cover:
 - a. As with stock pot cooking, an optional cover can speed up the heating of water and food products. It helps retain heat and reduces the heat and humidity in the kitchen. A cover can reduce some product cook times and help maintain the temperature, color and texture of products held or simmered for longer periods.
 - b. Be sure the handle is secure on the lift-off cover before using. ALWAYS use the handle to place or remove cover from the kettle. Wear protective oven mitts and apron.
 - c. When putting the cover on the kettle, position it on top of kettle rim, with its flat edge facing the pouring lip.
 - d. When removing cover:
 - 1) Firmly grasp plastic handle.
 - 2) Lift rear edge (farthest from operator) 1-2" (3-5 cm) to allow any steam and water vapor to escape the cooking vessel. Wait 2-3 seconds.
 - 3) Tilt cover to 45-60° angle and allow any hot condensate or product to roll off cover back into kettle.
 - 4) Remove cover, ensuring that any remaining hot condensate or product does not drip on operator, floor or work surfaces.
 - 5) Place cover on safe, flat, sanitary, out-of-the-way surface, or return to kettle rim.

2. Basket Insert:

- a. An optional kettle basket insert can assist in cooking water-boiled products including eggs, potatoes, vegetables, shell fish, pasta and rice. The nylon mesh liner must be used when cooking product smaller than the mesh size of the basket, which is approximately 1/4" (6 mm). This includes rice and small pasta shapes.
- b. Tips For Use:
 - 1) Allow for the water displacement of the basket and product to be cooked. This may mean only filling the kettle half full of water. Test the basket and product displacement with the kettle OFF, and with cold water in the kettle.
 - 2) Load basket on a level, stable work surface.
 - 3) Lift the loaded basket with both hands. Get help from another person if the basket is too heavy for safe handling. Then slowly lower product into kettle.
 - 4) When removing basket with cooked product, lift basket straight up, ensuring bottom of basket clears the rim and pouring lip of the kettle. Wear protective oven mitts and protective apron.
 - 5) Allow hot water to fully drain from product, before moving basket away from the kettle. Do not rest kettle basket on kettle rim or pouring lip. If basket is too heavy for individual to lift and safely move, get help from another person. Remove product immediately from basket into another container, being sure to avoid contact with hot product and hot basket or place basket with food on stable, flat surface, setting it inside a solid steamer or bake pan, to catch any remaining hot water draining from product.

4. Film remover such as Klenzade LC-30.

PRECAUTIONS

Before cleaning, shut off the kettle by turning the main power switch to "OFF," and shut off all electric power to the unit at a remote switch, such as the circuit breaker.

PROCEDURE

1. Clean food-contact surfaces as soon as possible after use. If the unit is in continuous use, thoroughly clean and sanitize the interior and exterior at least once every 12 hours.
2. Scrape and flush out food residues. Be careful not to scratch the kettle with metal implements. (For DHS/T models only: After flushing the kettle, close the draw-off valve.)
3. Prepare a hot solution of the detergent/ cleaning compound as instructed by the supplier. Clean the unit thoroughly. A cloth moistened with cleaning solution can be used to clean controls, housings, and electrical conduits.
4. Model DHS/T only: Disassemble the tangent draw-off valve. Clean the draw-off port and each valve part with a brush.
5. Rinse the kettle and draw-off valve parts thoroughly with hot water, then drain completely.
6. As part of the daily cleaning program, clean soiled external and internal surfaces. Remember to check the sides of the unit and control housing, underside of cover, etc.
7. To remove burnt on foods, use a brush, sponge, cloth, plastic or rubber scraper, or plastic wool with the cleaning solution. To reduce effort required in washing, let the detergent solution sit in the kettle and soak into the residue. Do NOT use abrasive materials or metal tools that might scratch the surface. Scratches make the surface harder to clean and provide places for bacteria to grow. Do NOT use steel wool, which may leave particles in the surface and cause eventual corrosion and pitting.
8. The outside of the unit may be cleaned with a warm water (100°F or less) spray. Do not use a high pressure spray.
9. The outside of the unit may be polished with a stainless steel cleaner such as "Zepper" from Zep Manufacturing Co.
10. When equipment needs to be sanitized, use a solution equivalent to one that supplies 200 parts per million available chlorine. Obtain advice on sanitizing agents from your supplier of sanitizing products.
11. It is recommended that each piece of equipment be sanitized just before use.
12. Clean the kettle thoroughly. If there is difficulty removing mineral deposits or a film left by hard water or food residues, then use a de-liming agent, following manufacturer directions.
13. Rinse and drain the unit thoroughly before further use.
14. If cleaning problems persist, contact your cleaning product representative for assistance. The supplier has a trained technical staff with laboratory facilities to serve you.

CLEANING

WARNING: KEEP WATER AND SOLUTIONS AWAY FROM CONTROLS AND ELECTRICAL EQUIPMENT. NEVER SPRAY THE SUPPORT HOUSING OR ELECTRICAL CONNECTIONS.

CAUTION: MOST CLEANERS ARE HARMFUL TO THE SKIN, EYES, MUCOUS MEMBRANES, AND CLOTHING. PRECAUTIONS SHOULD BE TAKEN. WEAR RUBBER GLOVES, GOGGLES OR FACE SHIELD, AND PROTECTIVE CLOTHING. READ THE WARNINGS AND FOLLOW THE DIRECTIONS ON THE LABEL OF THE CLEANER CAREFULLY.

CAUTION: NEVER LEAVE A SANITIZER IN CONTACT WITH STAINLESS STEEL SURFACES LONGER THAN 30 MINUTES. LONGER CONTACT CAN CAUSE CORROSION.

CAUTION: DO NOT MIX PARTS OF DIFFERENT DRAWOFF VALVE ASSEMBLIES. THE PARTS ARE NOT INTERCHANGEABLE.

WARNING: AVOID DIRECT CONTACT WITH HOT SURFACES. DIRECT SKIN CONTACT COULD RESULT IN SEVERE BURNS.



Use a brush, sponge, cloth, plastic or rubber scraper, or plastic wool to clean.



Don't use metal implements or steel wool when cleaning.



SUGGESTED CLEANING SUPPLIES

1. Cleaner, such as Klenzade HC-10 or HC-32 from ECOLAB, Inc. or equivalent.
2. Kettle brushes in good condition
3. Sanitizer such as Klenzade XY-12.

MAINTENANCE

WARNING: AVOID ANY EXPOSURE TO THE STEAM BLOWING OUT OF THE PRESSURE RELIEF VALVE. SEVERE BURNS CAN RESULT ON EXPOSED SKIN. FAILURE TO CHECK PRESSURE RELIEF VALVE OPERATION PERIODICALLY COULD RESULT IN PERSONAL INJURY AND/OR DAMAGE TO EQUIPMENT.

CAUTION: KEEP GREASE AWAY FROM ELECTRICAL PARTS LOCATED NEAR THE GEARS.

WARNING: TO AVOID INJURY, READ AND FOLLOW ALL PRECAUTIONS STATED ON THE LABEL OF THE WATER TREATMENT COMPOUND.

WARNING: USE OF ANY REPLACEMENT PARTS OTHER THAN THOSE SUPPLIED BY THE MANUFACTURER OR THEIR AUTHORIZED DISTRIBUTORS CAN CAUSE INJURY TO THE OPERATOR AND DAMAGE TO THE EQUIPMENT AND WILL VOID ALL WARRANTIES.

CAUTION: INSURE ELECTRICAL POWER IS REMOVED AND THE GAS IS TURNED OFF AT THE SHUTOFF VALVE PRIOR TO PERFORMING ANY MAINTENANCE ON THIS KETTLE.

WARNING: THIS KETTLE IS DESIGNED TO BE WATER RESISTANT. FAILURE TO FOLLOW PROPER MAINTENANCE PROCEDURES MAY VOID THE WARRANTY.

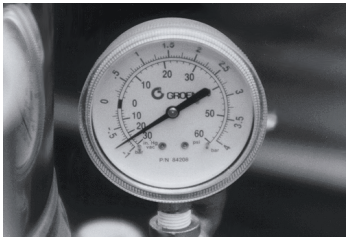

The pressure gauge should show a vacuum of 20 to 30 inches when the kettle is cold.

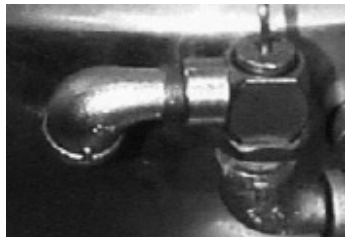

The open end of the pressure relief valve elbow must face downward.

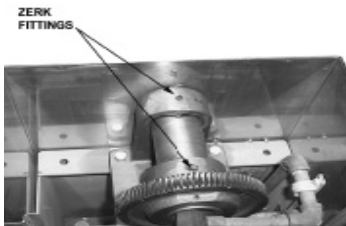

Add grease through Zerk Fittings.



Liberal grease the wheel where it contacts the worm gear.

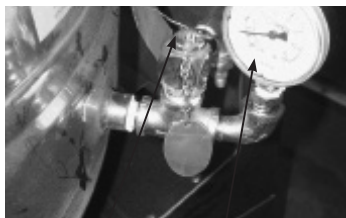

Safety Valve Pressure Gauge

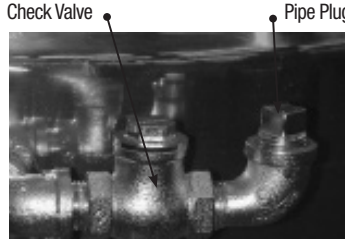

Check Valve Pipe Plug
Test the safety valve at least twice monthly.



PERIODIC MAINTENANCE

NOTICE: Contact an authorized representative when repairs are required.

A Maintenance & Service Log is provided at the back of this manual. Each time maintenance is performed on your kettle, enter the date on which the work was done, what was done, and who did it. Keep this manual on file and available for operators to use. Periodic inspection will minimize equipment down time and increase the efficiency of operation. The following points should be checked:

1. Check the pressure/vacuum gauge every day. The gauge should show a vacuum of 20 to 30 inches mercury (Hg), when the kettle is cold. If it does not, see "Jacket Vacuum" in this manual.
2. Also check the jacket water level every day. It should be in the middle of the sight glass. If the level is low, see "Jacket Filling and Water Treatment" in this manual.
3. Carefully test the pressure relief valve at least twice each month. With the kettle operating at five psi (105 kPa), pull the test lever and let it snap back to its closed position. If there is little discharge (mostly air), and the pressure gauge drops back to zero PSI, allow the pressure to build back to five PSI and repeat the procedure. (Tip: Using a screwdriver or other implement to pull the ring will help you avoid contact with the steam.)
4. If the valve does not activate, or there is no evidence of discharge, or the valve leaks, stop using the kettle and contact a qualified Groen service representative.
5. Keep the primary burner gas jet air inlets free of dust and lint.
6. The pilot flame should be blue. It should envelop about ½ inch (12 mm) of the flame sensor tip.
7. The gear housing has fittings for lubrication of moving parts. The gears do not run in oil, so periodic lubrication with grease is necessary.
8. Frequency of lubrication depends on operating conditions, but it should be done at least once every six months.
9. Use a #2 grade LGI lithium grease to add grease through Zerk fittings on gear housing until it flows out of the bearings around the trunnion shaft.
10. Place liberal amounts of grease on the gear to cover the arc that is in contact with the worm gear.
11. Keep electrical wiring and connections in good condition.
12. Keep the inside of the control console clean and dry.
13. Keep burner slots clean.

JACKET VACUUM/REMOVING AIR FROM JACKET

When the kettle is cold, a positive pressure reading on the pressure/vacuum gauge or a reading near zero indicates that there is air in the jacket. Air in the jacket acts as an insulator, and slows kettle heating.

To remove air:

1. Start the unit. (Be sure there is water or product in the kettle when heating).
2. When the pressure/vacuum gauge reaches a positive pressure reading of five PSI, release the trapped air and steam by pulling up the safety valve ring for about five seconds. Repeat this step three or four times. Then let the pull ring snap back into the closed position.
3. If there is little discharge (mostly air), and the pressure gauge drops back to zero PSI, allow the pressure to build back to five PSI and repeat the procedure.
4. Once steam has been vented from the jacket as described in b, above, remove the hot water from the kettle and replace it with cold. This will condense steam in the kettle jacket, and the pressure gauge should show a reading of 20 to 30 inches mercury (Hg) below zero. If it does not, or if the vacuum is leaking down, contact a Groen authorized service agency to correct the problem.

JACKET FILLING AND WATER TREATMENT

The jacket was charged at the factory with the proper amount of treated water. You may need to restore this water, either because it was lost as venting steam or by draining. If you are replacing water lost as steam, use distilled water. If you are replacing treated water that ran out of the jacket, prepare more treated water as directed in "Water Treatment Procedure," below.

1. Allow the kettle to cool completely. The procedure will be easier with the kettle under vacuum (pressure gauge reading below zero).
2. Make sure the fill valve is closed, and remove the square head pipe plug with open-ended wrench.
3. Position a funnel in the opening and fill it with properly treated water.

4. Slowly open the fill valve to allow water to be sucked into the jacket. Quickly close the valve to prevent air from entering.
5. Check water level in the jacket to ensure that it is between minimum and maximum marks on glass or at the top of the sight glass port for models DH/DHT-80.
6. Close the valve and reinstall the squarehead pipe plug.
7. Reestablish the jacket vacuum as described above, if the pressure gauge does not show a negative reading of 20 to 30 inches mercury (Hg).

WATER TREATMENT PROCEDURE

1. Obtain water treatment compound and a pH test kit from your Groen Service Agent.
2. Fill a mixing container with the measured amount of water required. Use only distilled water.

Model	Recommended Jacket Fill
DHS-40, DHS/T-40 (C,A,C2T)	4 gallons

3. Hang a strip of pH test paper on the rim of the container, with about 1 inch of the strip below the surface of the water.
4. Measure the water treatment compound. One way to do this is to add the compound from a measuring cup.
5. Stir the water continuously, while you slowly add treatment compound, until the water has a pH between 10.5 and 11.5. Judge the pH by frequently comparing the test strip color with the color chart provided in the test kit. Caution: Do not add excess amount of treatment compound. Excess amount could cause extensive corrosion.
6. As you add water to the jacket, check water level to ensure that it is in the middle of the sight glass.
7. Record the exact amounts of water and treatment compound needed. These amounts may be used again, if the same water sources and compound are used. However, it is best to check the pH each time treated water is prepared.

COMPONENT REPLACEMENT

When component replacement involves breaking a gas pipe connection, check the new connection with soap solution or an appropriate leak detector. **DO NOT USE A FLAME TO TEST FOR LEAKS.**

Internal wiring is marked as shown on the circuit schematic drawings (inside control housing and in this manual). Be sure that new components are wired in the same manner as old components. An examination of the circuit schematic shows that the safety components are wired in series. In most cases, a faulty component may be isolated with a jumper wire to verify that the component is faulty. If this determination is made, contact a certified Groen Service Agency for assistance.

SEQUENCE OF OPERATION

The following "action-reaction" outline is provided to help understand how the kettle works.

1. When the power switch is turned on, it starts the spark igniter and opens the automatic valve for the pilot burner. The spark ignites a pilot flame, which heats the sensor. The sensor then sends a signal to turn off the spark. The flame thereafter acts as a standing pilot until the power is turned off.
2. If the pilot flame is not sensed within 90 seconds after spark begins, a timer shuts down the entire operation. To attempt a second trial for ignition, turn off the power switch. Check the gas supply valves and wait five minutes before trying again by switching power on. If you cannot establish a pilot flame in four tries, close all valves, turn off the power, and contact an authorized Service Agency.
3. When the operator sets a temperature on the controller, it causes the automatic valve to admit gas to the main burner, where it is ignited by the pilot flame. When the kettle reaches the set temperature, the relay switch opens. This stops the signal to the gas control valve and shuts off gas to the main burner. The pilot flame remains lit. When the kettle cools below the set temperature, the relay switch closes and starts another cycle. On and off cycling continues and maintains the kettle at the desired temperature. This action is indicated by the Heat indicator light.

The kettle has the following safety features in addition to the 90-second ignition timer:

1. Low water cutoff relay that will shut off gas supplies to all burners until the jacket water level is corrected.
2. High limit pressure switch, set to open at about 43 PSI and to shut down the burners until jacket pressure is decreased.
3. Pop safety valve, which will release steam if jacket pressure exceeds 50 PSI.
4. Tilt switch, which shuts off all burners when the kettle is tilted.
5. Gas pressure regulator built into the gas control valve.

REPLACEMENT PARTS

To order parts, contact your Authorized Service Agent. Supply the model designation, serial number, part description, part number, quantity, and when applicable, voltage and phase.

CONTACT US

If you have questions pertaining to the content in this manual, contact Groen at 888-994-7636.

TROUBLESHOOTING

This unit is designed to operate smoothly and efficiently if properly maintained. However, the following is a list of checks to make in the event of a problem. Wiring diagrams are found at the end of this manual. When in doubt, turn unit off and call for service at 888-994-7636. If an item on the check list is marked with (X), it means that the work should be done by an Authorized Service Agent.

SYMPTOM	WHO	WHAT TO CHECK X indicates items which must be performed by authorized technician.
Display not lit (Advanced & C2T only)	User	a. That power supply is on.
	Auth Service Rep Only	b. Fuses, accessible by removing caps on the side of the control box. c. For loose or broken wires. X d. Temperature controller functioning, by listening for a click when the switch opens or closes and verifying LEDs on back of board. X e. Contactor functioning. X
PROB in display (Advanced & C2T only)	Auth Service Rep Only	a. For loose or broken wires or damaged/failed RTD probe. X b. PCB board malfunction/failure
HI in display (Advanced & C2T only)	Auth Service Rep Only	a. For loose or broken wires or damaged/failed RTD probe. X b. PCB board malfunction/failure
Kettle is hard to tilt	User	a. Gears for foreign materials, and lubrication.
	Auth Service Rep Only	b. Gears for alignment. X c. Worm gears or broken gears. X
Kettle continues heating after it reaches the desired temperature	User	a. Temperature Controller dial setting.
	Auth Service Rep Only	b. Temperature Controller calibration and offset. X c. Temperature Controller operation. The Temperature Controller should click when the dial is rotated to settings above and below the temperature of the kettle. X
Kettle stops heating before it reaches the desired temperature	User	a. Temperature Controller dial setting.
	Auth Service Rep Only	b. Temperature Controller calibration and offset. X c. Temperature Controller operation. The Temperature Controller should click when the dial is rotated to settings above and below the temperature of the kettle. X
Safety Valve pops open	User	a. For air in the jacket. See "Jacket Vacuum" in the Maintenance b. Temperature Controller dial setting.
	Auth Service Rep Only	c. For defective Temperature Controller. The relay should click when the dial is rotated to settings above and below the temperature of the kettle. If defective, replace. X d. For defective safety valve. If the valve pops at pressures below 49 PSI, replace. X
Burners will not light	User	a. That the main gas supply valve is open. (handle is in line with gas pipe). b. Gas supply to the building. c. That the kettle body is not tilted.
	Auth Service Rep Only	d. Temperature Controller operation. The relay should click when the dial is rotated to settings above and below the temperature of the kettle. X e. That tilt limit switch is closed when body is not tilted. X
System does not produce a spark	Auth Service Rep Only	a. AC voltage between terminals on secondary side of transformer. If it is not 24 Volt, replace the transformer. X b. That the high tension cable is firmly attached and in good condition. If cracked or brittle, replace. X c. Pilot electric ceramic for crack or break. X d. Pilot spark gap. Regap. X
Safety valve leaks a small amount of steam when kettle is operating	User	a. For contamination that prevents seating of the valve. With full pressure in the jacket, pull the lever all the way briefly to blow the valve clean, then let the lever snap back to seat the valve
	Auth Service Rep Only	b. Safety valve for defects. Replace any defective valve with an identical valve. X

Spark is present but the pilot will not light	Auth Service Rep Only	a. That the pilot valve is securely connected to terminals. X b. For 24 VAC at terminals PV and PV/MV. If 24V is not present, replace the ignition control module. X c. That gas pressure is at least 3.5" W.C. (8.7818 ub). d. For gas at the pilot. If it is not flowing: (1) Check the pilot gas line for kinks and obstructions. X (2) Clean orifice, if necessary. X (3) Check magnetic operator for pilot valve on gas valve. Repair or replace as necessary. X e. That the pilot spark gap is located in the pilot gas stream. If not, adjust or replace the pilot burner. X f. For drafts. Shield the pilot burner, if necessary. X
Pilot lights, but main burner will not come on and spark does not stay on	Auth Service Rep Only	a. For 24 V between terminals MV and PV/MV while pilot is burning. If 24V is not present, replace the ignition control module. X b. That gas pressure is at least 3.5" W.C. (8.7818 ub). X c. Electrical connections of the main valve to terminals, to assure that they are securely attached. Check magnetic operator for main valve on gas valve. Repair or replace as necessary. X
Pilot lights, but main burner will not come on, the spark stays on	Auth Service Rep Only	a. Check for bad burner ground. If necessary, repair with high temperature wire. X b. Pilot burner ceramic insulator for cracks. X c. That cable is not grounded out. If it is, correct the ground-out condition or replace cable. X d. For proper gas pressure. X e. Clean pilot assembly, or replace if necessary. X f. Tighten all mechanical and electrical connections. X g. If the pilot flame is weak, increase pilot orifice size. X h. Replace ignition control module. X
Main burner comes on but will not stay on	Auth Service Rep Only	a. Check burner ground for bad wire or connection. Replace if necessary with high temperature wire. X b. Check for low gas supply pressure. If necessary, replace ignition control module. X
C2T in display (C2T only)	User	a. That core probe is plugged into the receptacle.
	Authorized Service Rep Only	b. For loose or broken wires or damaged/failed RTD probe. X c. PCB board malfunction/failure. X

Parts List

HARDWARE ASSEMBLY

Key	Description	Part #
1	SIGHT GLASS 1-1/4" NPT	108554
2	FAUCET BRACKET	137738
3	FOOT, ADJUSTABLE, FLANGED, FITS 2" TUBE	Z096569
3	FOOT, ADJUSTABLE, BULLET, FITS 2" TUBE	Z013275
4	ASSEMBLY, TILT MECHANISM	Z045752
5	ASSEMBLY, SUPPORT BRACKET, GAS LINE	Z068132
6	VALVE, GAS, MANUAL SHUTOFF, 1/2 NPT	Z098458
7	KNOB, THERMOSTAT DIAL	175095
8	ASSEMBLY, TILT SWITCH	135331
9	RELIEF VALVE WITH GAUGE	139395
10	PIPING ASSEMBLY, WATER FILL	139396
11	KETTLE ARM & IGNITION MODULE BOX ASSEMBLY	123734
12	COMPONENT BOX	175337

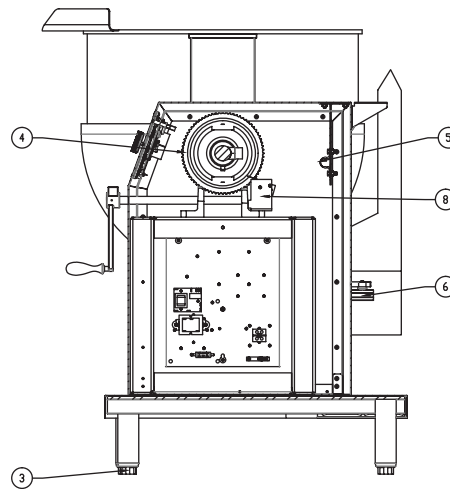
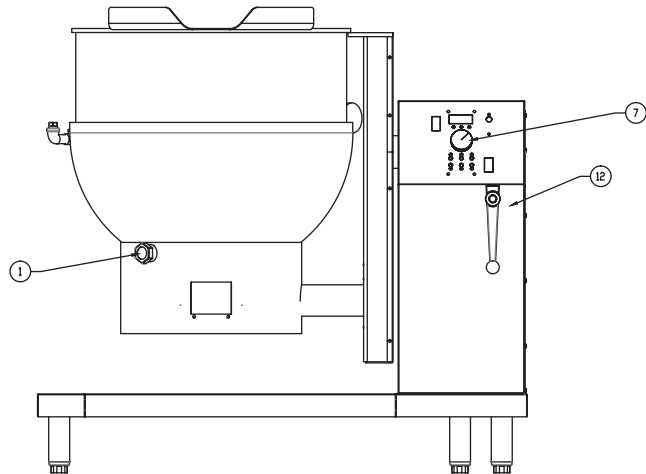
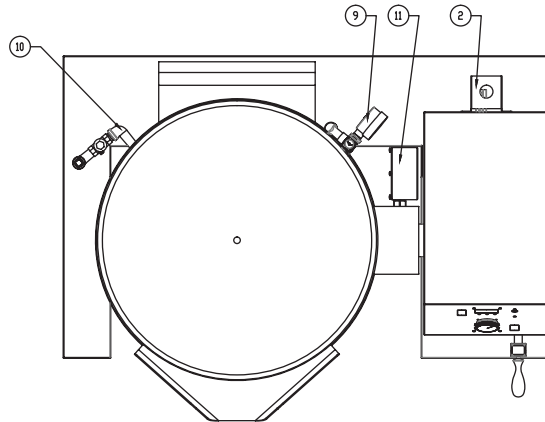

Parts List

TILT MECHANISM ASSEMBLY

Key	Description	Part #
1	BUSHING, SNAP, 3/4 ID	Z000453
2	KEY, SQUARE, 3/8"	Z001474
3	SCREW, CAP, SOCKET HEAD, 3/8-16	Z005097
4	WASHER, LOCK, SPLIT, 3/8	Z005618
5	NUT, HEX, 1/2-13	Z005705
6	WASHER, LOCK, 1/2	Z005735
7	NUT, HEX, 3/8-16	Z005619
8	SCREW, CAP, HEX HEAD, CAP, 1/2-13, 1-1/2" LONG	Z008679
9	HOUSING, BEARING ASSY	Z009762
10	BEARING, BALL	Z009765
11	GEAR, WORM, 3/4 BORE	Z012026
12	SHIM, 0.01" THICK	Z012039
13	SCREW, SET, SOCKET, 5/16-18, 1/2" LONG	Z012060
14	PIN, ROLL, 1/4 DIA, 1-1/4" LONG	Z012614
15	RING, INTERNAL, RETAINING	Z013483
16	GEAR, 3" BORE, 92 TEETH	Z013609
17	HANDLE, CRANK, 3/4 BORE	Z013617
18	SHAFT, HANDLE, 3/4	Z013624
19	SPACER, SCHEDULE 40, 3"	Z013625
20	SHIM, TRUNNION, 16 GA	Z088246
20	SHIM, TRUNNION, 1/8"	Z088247
-	SPACER WASHER, WORM GEAR	Z004901
-	WASHER, PLAIN, 1/2	Z005049
-	WASHER, SHIM, 1-3/8 ID	Z012039

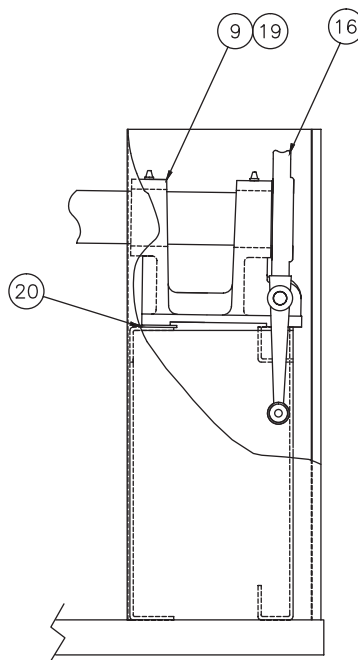
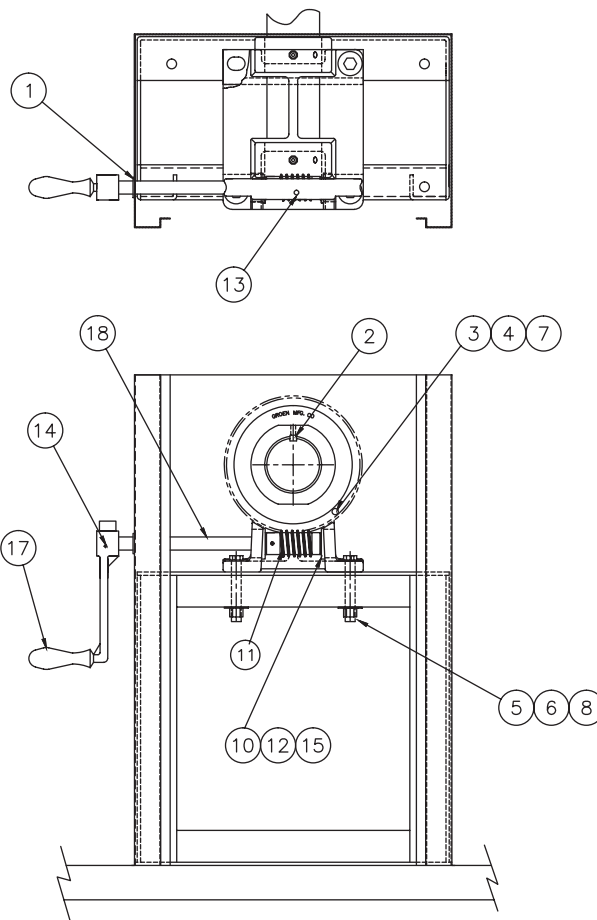

Parts List

GAS LINE SUPPORT BRACKET ASSEMBLY

Key	Description	Part #
1	WELDMENT, SUPPORT BRACKET, GAS	Z068133
2	NUT- HEX SERRATED, 1/4-20	NT1101
3	STRAP, CONDUIT, 3/4 EMT	135252
4	SCREW, CAP, HEX HEAD, 1/4-20, 3/4" LONG	Z005609

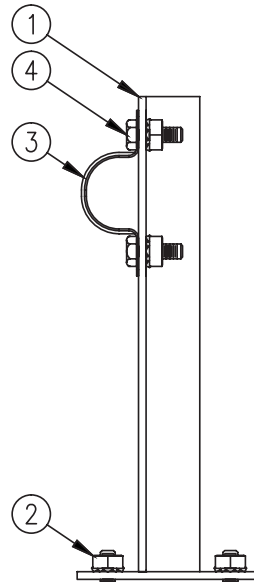

For Classic Control Models

Parts List

DHS FRONT PANEL ASSEMBLY

Key	Description	Part #
1	2" ALUMINUM KNOB	175095
2	POWER SWITCH	176921
3	INDICATOR LIGHT, AMBER	116384
4	INDICATOR LIGHT, RED	116383
-	CLASSIC CONTROLS OVERLAY	175303
-	HEX NUT	101145
-	SPACER, LIGHT MOUNT	175221
-	BRACKET, LIGHT MOUNT	175222

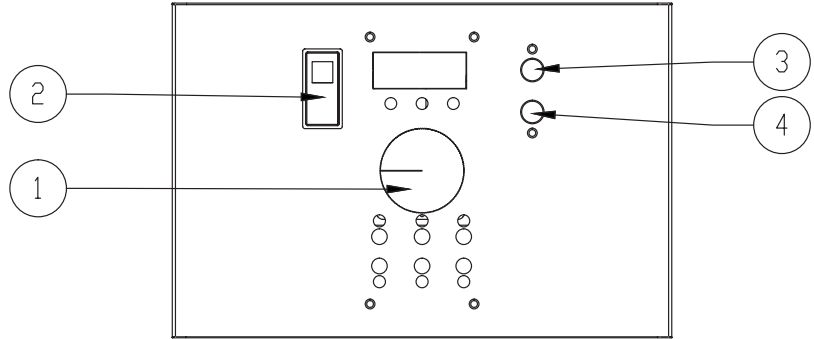

For Advanced Control Models

Parts List

DHS FRONT PANEL ASSEMBLY

Key	Description	Part #
1	2" ALUMINUM KNOB	174829
2	POWER SWITCH	176921
3	INDICATOR LIGHT, AMBER	116384
4	INDICATOR LIGHT, RED	116383
-	ADVANCED CONTROLS OVERLAY	175304
-	HEX NUT	101145
-	SPACER, LIGHT MOUNT	175221
-	BRACKET, LIGHT MOUNT	175222

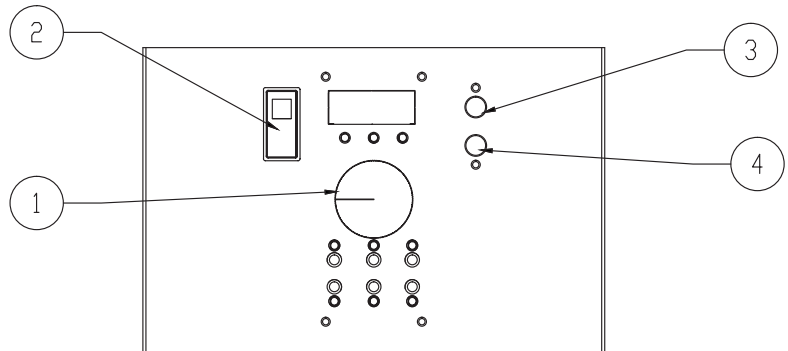

For Cook2Temp™ Control Models

Parts List

DHS FRONT PANEL ASSEMBLY

Key	Description	Part #
1	2" ALUMINUM KNOB	174829
2	POWER SWITCH	176921
3	INDICATOR LIGHT, RED	116383
4	C2T CONTROLS	176895
5	HEX NUT	101145
6	INDICATOR LIGHT, AMBER	116384
-	SPACER, LIGHT MOUNT	175221
-	BRACKET, LIGHT MOUNT	175222
-	OVERLAY, C2T CONTROL	176891
-	CAP, SOCKET, PANEL MOUNT, CORE PROBE, C2T	176927
-	SOCKET, PANEL MOUNT ASSY, CORE PROBE, C2T	176925
-	CORE PROBE, DHS-40, C2T	176651
-	BRACKET, CORE PROBE, DHS-40, C2T	176656
-	BRACKET ASSEMBLY, CORE PROBE STORAGE	177091
-	WIRE HARNESS, CONTROL, CORE PROBE, C2T	176920

Parts List

TILT SWITCH ASSEMBLY

Key	Description	Part #
1	BRACKET, TILT SWITCH	160482
2	BARRIER, INSULATION	Z003490
3	SWITCH, MICRO	Z002982
4	SCREW, ROUND HEAD, 4-40, 3/4" LONG	Z003122
5	NUT, HEX KEPS, 4-40	Z071297

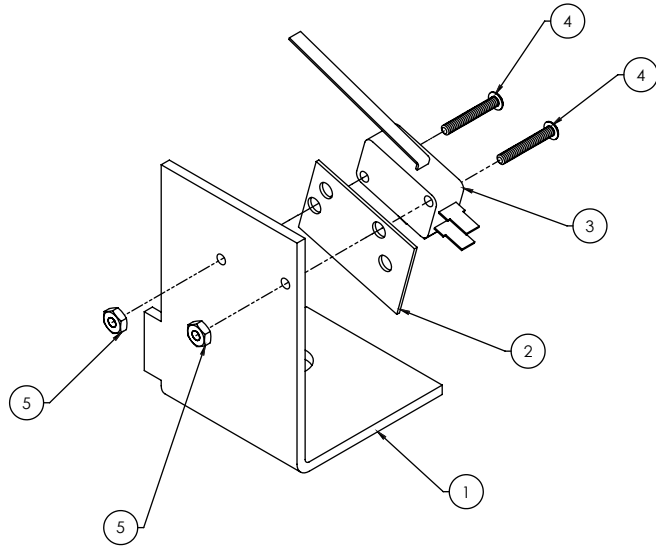

Parts List

RELIEF VALVE WITH GAUGE

Key	Description	Part #
1	VALVE, SAFETY, 50 PSI, 1/2 NPT	Z097005
2	GAUGE, COMPOUND, PRESSURE, DUAL SCALE	Z084208
3	ELBOW, STREET, 90 DEG, 1/2 NPT, CHROME PLATED	Z010108
4	ASSEMBLY, PLATE/CHAIN ASM	Z008332
5	ASSEMBLY, RELIEF VALVE PIPING	141428

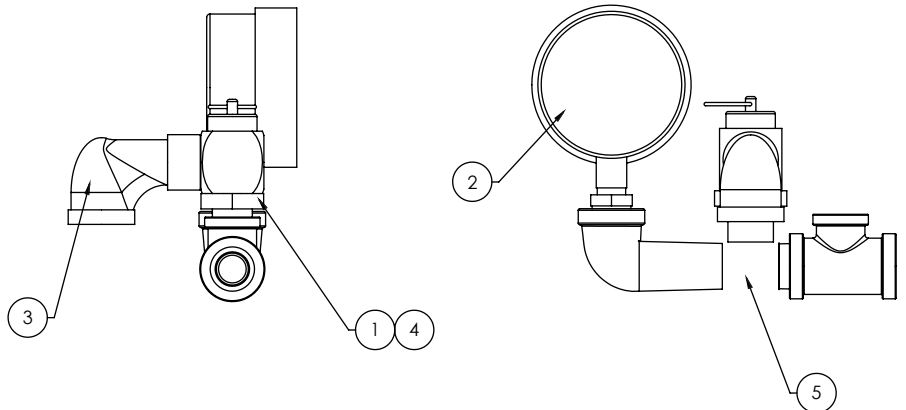

Parts List

RELIEF VALVE PIPING ASSEMBLY

Key	Description	Part #
1	TEE, 1/2 NPT	Z008772
2	ELBOW, STREET, 90 DEG, 1/2 NPT	Z004185
3	NIPPLE, CLOSE, 1/2 NPT	Z008877
4	BUSHING, REDUCING, 1/2 NPT	Z008739

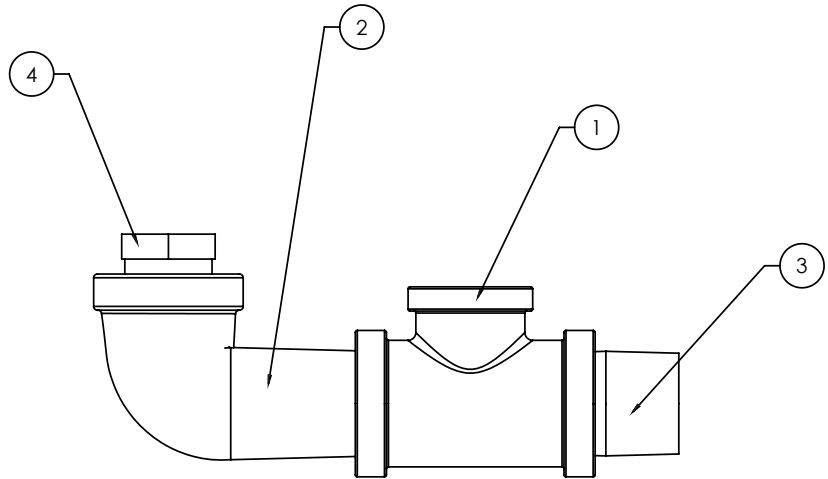

Parts List

WATER FILL ASSEMBLY

Key	Description	Part #
1	ELBOW, STREET, 90 DEG, 1/2 NPT	Z004185
2	NIPPLE, CLOSE, 1/2 NPT	Z008877
3	VALVE, SWING CHECK	Z004187
4	PLUG, PIPE, 1/2 NPT, SQUARE	Z011146

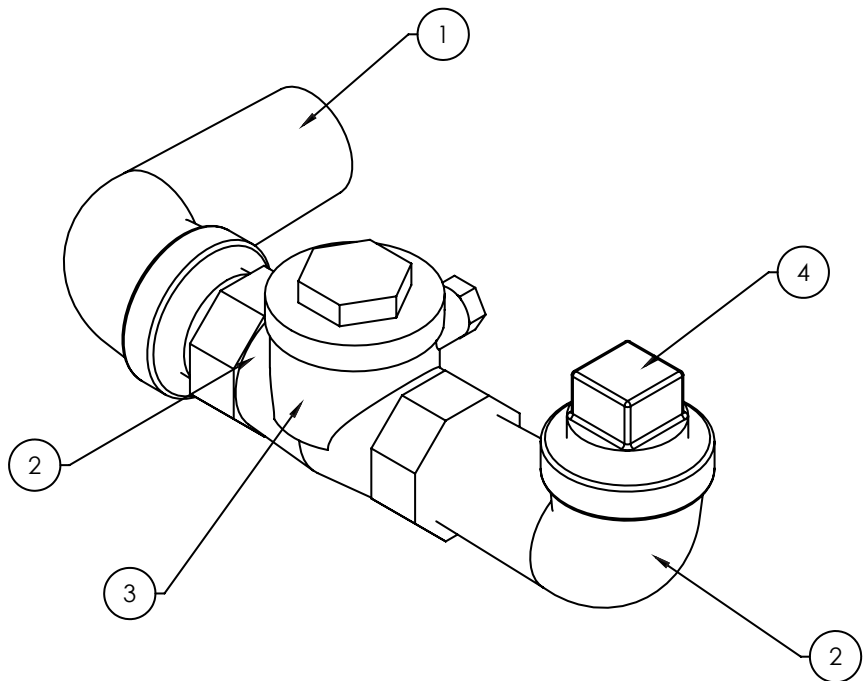

For Classic & Advanced
Control Models

Parts List

ELECTRICAL MOUNT ASSEMBLY

Key	Description	Part #
1	ASM, WATER LEVEL BOARD	122192
2	MOUNTING POST, PC BOARD	Z099901
3	LUG, GROUND, 14 TO 6 AWG	129714
4	SCREW, HEX, SLOTTED HEAD, 8-32, 3/8 LONG	Z069789
5	WELDMENT, ELEC PANEL	138123
6	NUT, HEX KEPS, 10-32	Z071256
7	TERMINAL BLOCK, 2-POLE	Z003887
8	FUSE HOLDER, TYPE 3 AG	Z077854
9	FUSE, TYPE 3 AG	Z077853
10	SCREW, ROUND HEAD, 8-32, 1-1/4" LONG	Z005056
11	TRANSFORMER, 20 VA 120/24V	137487
-	HARNESS, WIRING, PANEL CTRL	123582
-	WIRE HARNESS, CONTROL - PANEL, DH, CLASSIC/ADVANCED	175839
-	HARNESS, WIRING, KETTLE CONTROL	123779
-	HARNESS, WIRING, KETTLE CONTROL, DH, CLASSIC/ ADVANCED	175367
-	LABEL, ELECTRICAL CONNECTION, 115V	102229
-	SCREW, ROUND HEAD, SELF TAPPING	Z012398
-	STRAP, CABLE TIE	Z011093

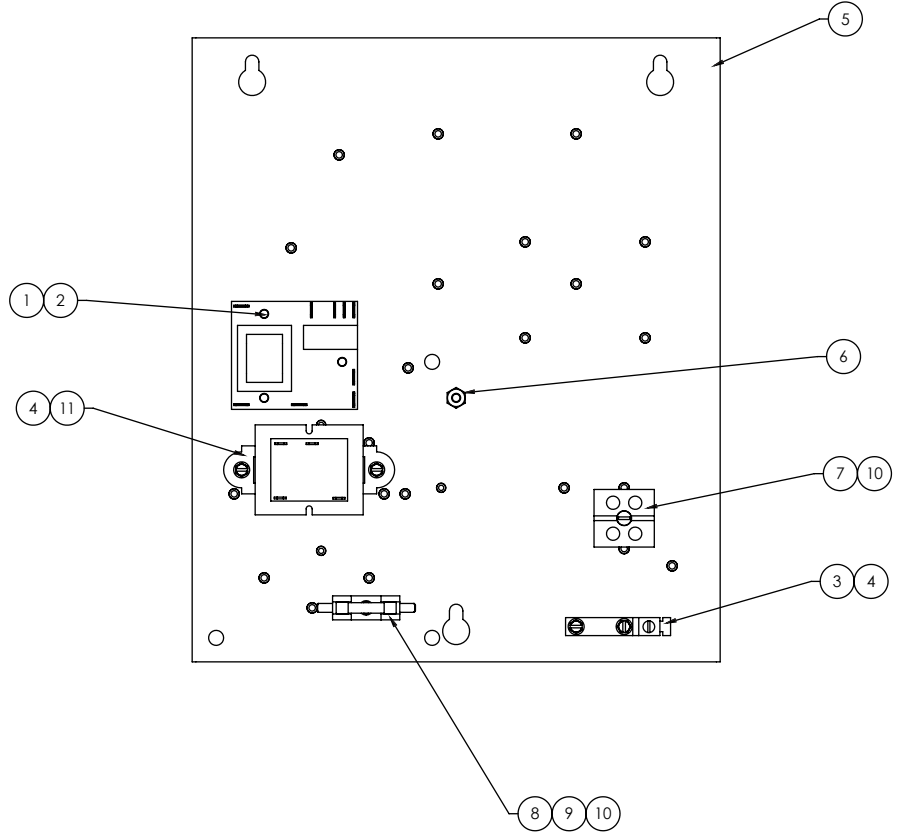

Parts List

ELECTRICAL MOUNT ASSEMBLY

Key	Description	Part #	Qty
1	WELDMENT, ELECTRICAL MOUNTING DEE & DH-40	138123	1
2	TERMINAL BLOCK 2P	003887	1
3	P.C. BOARD MOUNTING POST	099901	3
4	CONTROL BOARD ASSEMBLY, WATER LEVEL	122192	1
5	FUSE 3.0 AMP TYPE 3 AG	077853	2
6	FUSE HOLDER TYPE 3 AG	077854	2
7	TRANSFORMER, 20VA, 120 PRIMARY	137487	2
8	LUG GROUND #14-#6 AWG	129714	1
9	SCREW ROUND HEAD 8-32 1 1/4"	005056	1
10	SCREW HEX SLOTTED HD W/ WASHER #8-32 X 3/8"	069789	6
11	SCREW, ROUND HEAD #6-32X.375	012398	2
-	WIRE HARNESS, CONTROL, DH, C2T	176929	1
-	HARNESS, HIGH VOLTAGE WIRING, TDH	175387	2
-	WIRE HARNESS, CONTROL, PANEL, DH, C2T	176963	1
-	LABEL, ELECTRICAL CONNECTION, 115V	102229	1
-	STRAP, CABLE TIE	011093	1

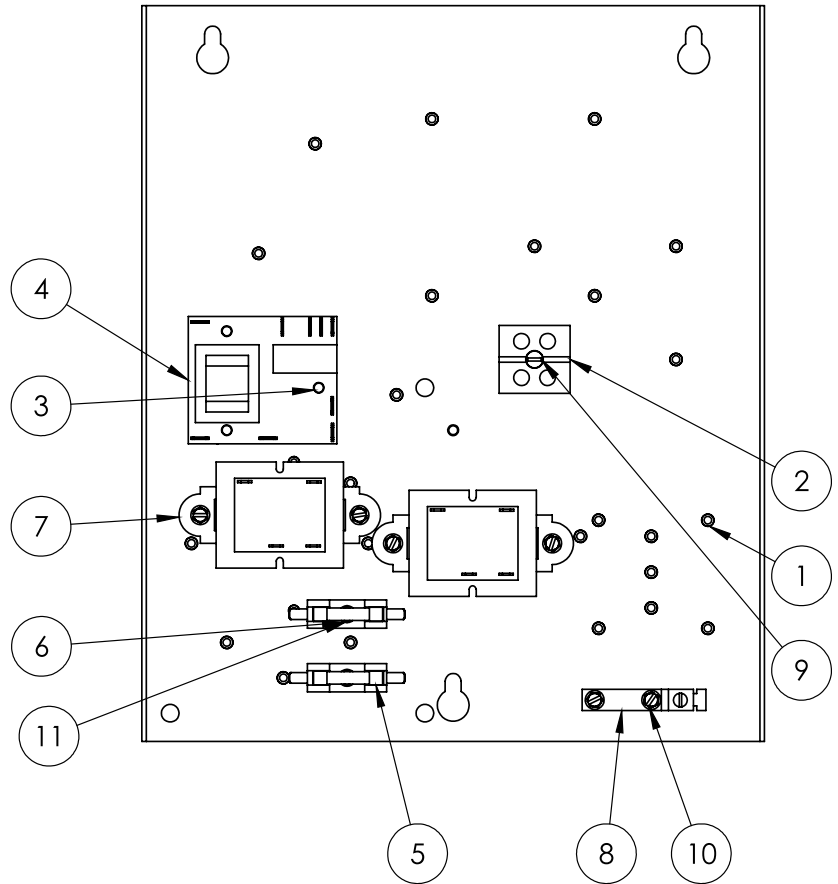

For Classic Control Models

Parts List

LABEL KIT

Key	Description	Part #
1	LABEL, 3 AMP, FAST-BLOW ONLY	102251
2	LABEL, 115 VOLTS	Z008118B
3	LABEL, SINGLE PHASE	Z008118K
4	LABEL, GROUND	Z003384
5	LABEL, WARNING, HIGH VOLTAGE	Z072140
6	LABEL, ELECTRICAL CONNECTION, 115V	102229
8	LABEL, WARNING	Z098171
9	LABEL, NSF	Z066735
11	OVERLAY, DH FRONT PANEL	123802
12	NAMEPLATE, DHS KETTLE	139075
13	LABEL, WARNING, PREHEATING	Z095070
14	LABEL, TDO VALVE CAUTION	110156
16	LABEL, CAUTION	Z002723
-	LABEL, WARNING, AGA ADDENDA "B"	Z099961
-	LABEL, WARNING, CALIFORNIA	Z093614
-	LABEL, WARRANTIES VOID	Z074816

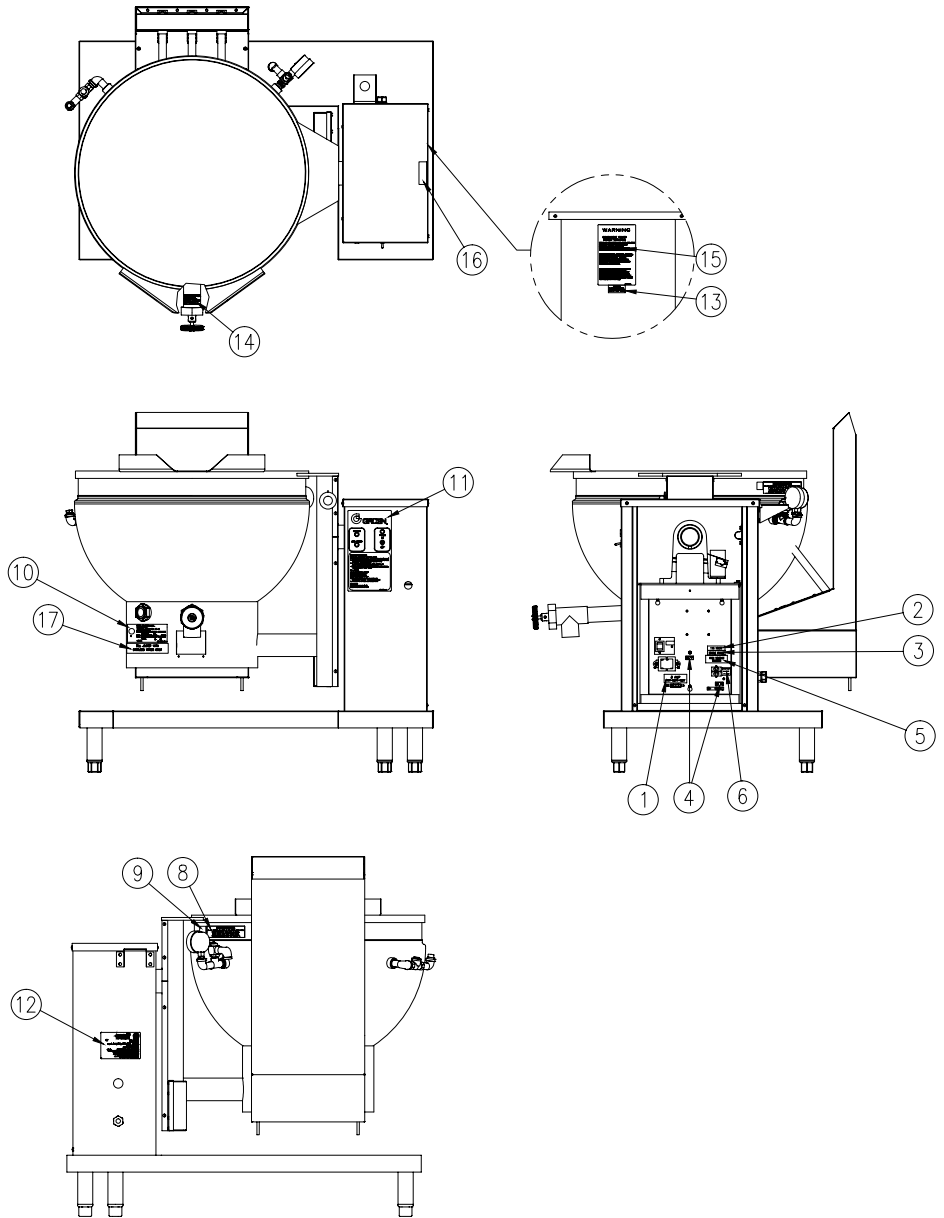

Parts List

LABEL KIT

Key	Description	Part #
1	"LABEL, 3 AMP FAST-BLOW ONLY	102251
"	102251	Z008118B
2	LABEL 115 VOLTS	Z008118B
3	LABEL SINGLE PHASE	Z008118K
4	LABEL GROUND .004" X 1/2" X 1" LONG	Z003384
5	LABEL WARNING	Z072140
6	LABEL, ELECTRICAL CONNECTION 115V	102229
7	LABEL, WARNING - FOR SELF	Z098171
8	LABEL NSF	Z066735
9	OVERLAY, ADVANCED, DH & DEE	175304
10	OVERLAY, CLASSIC, DH & DEE	175303
11	LABEL TDO VALVE CAUTION	110156
12	LABEL CAUTION	Z002723
13	LABEL WARNING	Z095070
-	LABEL WARNING AGA ADDENDA "B"	Z099961
-	LABEL WARNING CALIFORNIA	Z093614
-	OVERLAY, OPERATION INSTRUCTIONS, DH	175053
-	OPERATION OVERLAY, ADVANCED, TDH/TDHC	175609

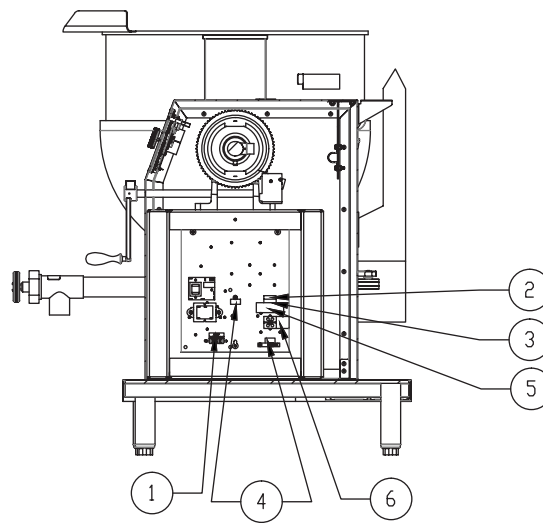
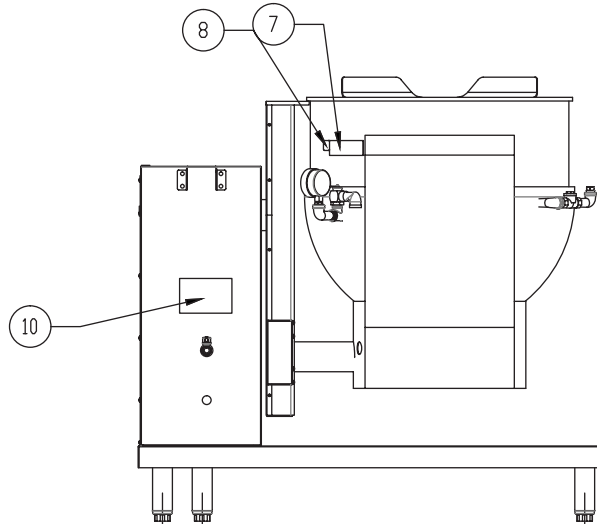
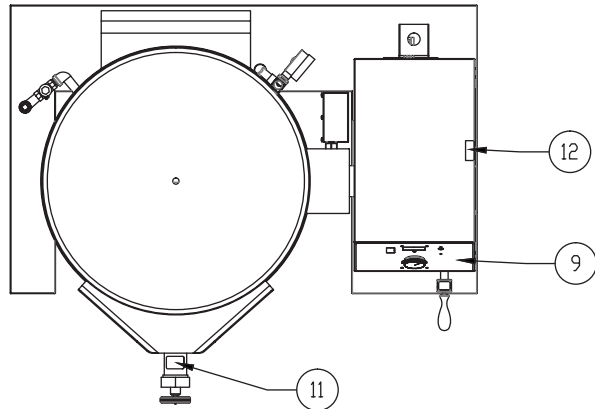

Parts List

STAND AND HOUSING ASSEMBLY

Key	Description	Part #
1	WELDMENT, FRAME, STAND	174802
2	WELDMENT, CLADDING, STAND	174812
3	WELDMENT, PEDESTAL	175330
4	WELDMENT, CLADDING, PEDESTAL	175337
5	SCREW, MACHINE, HEX HEAD, 1/2-13 X 1-1/2" LONG	008679
6	NUT, HEX, 1/2"-13	005603
7	WASHER, LOCK, 1/2	005657
8	WASHER, PLAIN, 1/2	005049
9	SCREW, MACHINE, TRUSS HEAD 8-32 X 3/8" LONG	137766
10	Nut, 10-32 Weld	069791
11	SCREW, TRS HEAD 10-32 X 3/8	004173
-	FOOT, ADJUSTABLE, BULLET-FITS 2" TUBE	013275
-	FOOT, ADJUSTABLE, FLANGED-FITS 2" TUBE	096569
-	PANEL, SIDE, PEDESTAL	175336

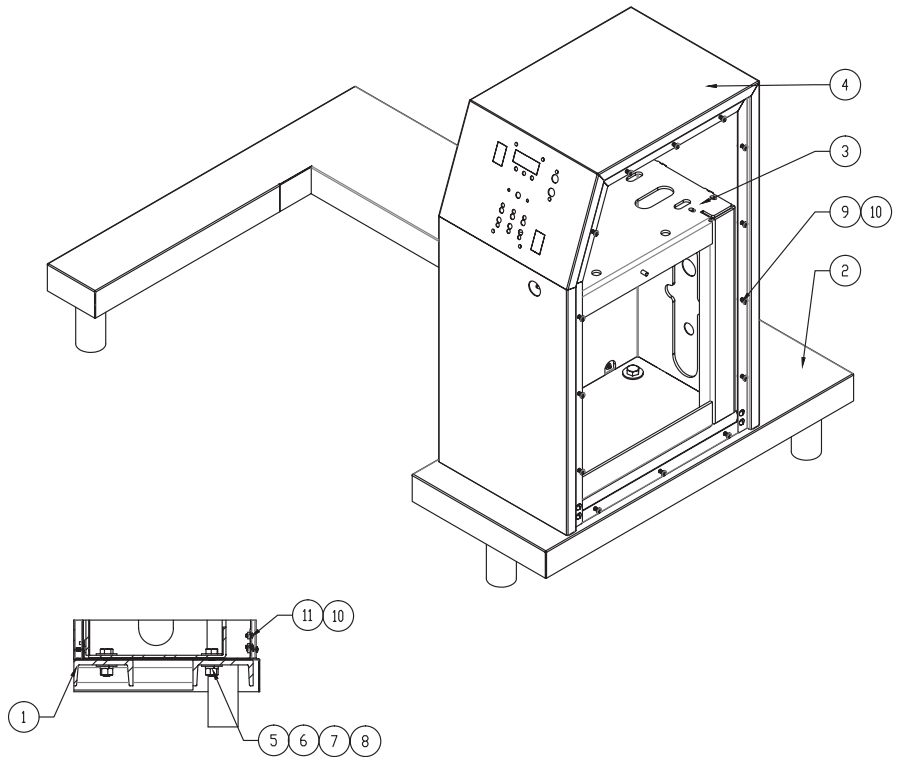

Parts List

BURNER AND FLAME SENSOR ASSEMBLY

Key	Description	Part #
1	BAFFLE PLATE, BURNER	123498
2	NUT, HEX SERRATED, 1/4-20	NT1101
3	PILOT BURNER, NAT GAS	123580
3	PILOT BURNER, PROPANE	128415
4	BRACKET, BURNER SUPPORT	117010
5	BRACKET, BURNER	117013
6	ASSEMBLY, BURNER, DHS, NAT N02	Z090644
6	ASSEMBLY, BURNER, DHS, NAT N24	158125
6	ASSEMBLY, BURNER, DHS, NAT N46	158128
6	ASSEMBLY, BURNER, DHS, NAT N68	158131
6	ASSEMBLY, BURNER, DHS, NAT N810	158134
6	ASSEMBLY, BURNER, DHS, PROPANE, P02	Z090628
6	ASSEMBLY, BURNER, DHS, PROPANE, P24	158137
6	ASSEMBLY, BURNER, DHS, PROPANE, P46	158140
6	ASSEMBLY, BURNER, DHS, PROPANE, P68	158143
6	ASSEMBLY, BURNER, DHS, PROPANE, P810	158146
-	KIT, CONVERSION, PROPANE	Z079802
-	WASHER, FENDER, 1/4 X 1	132107

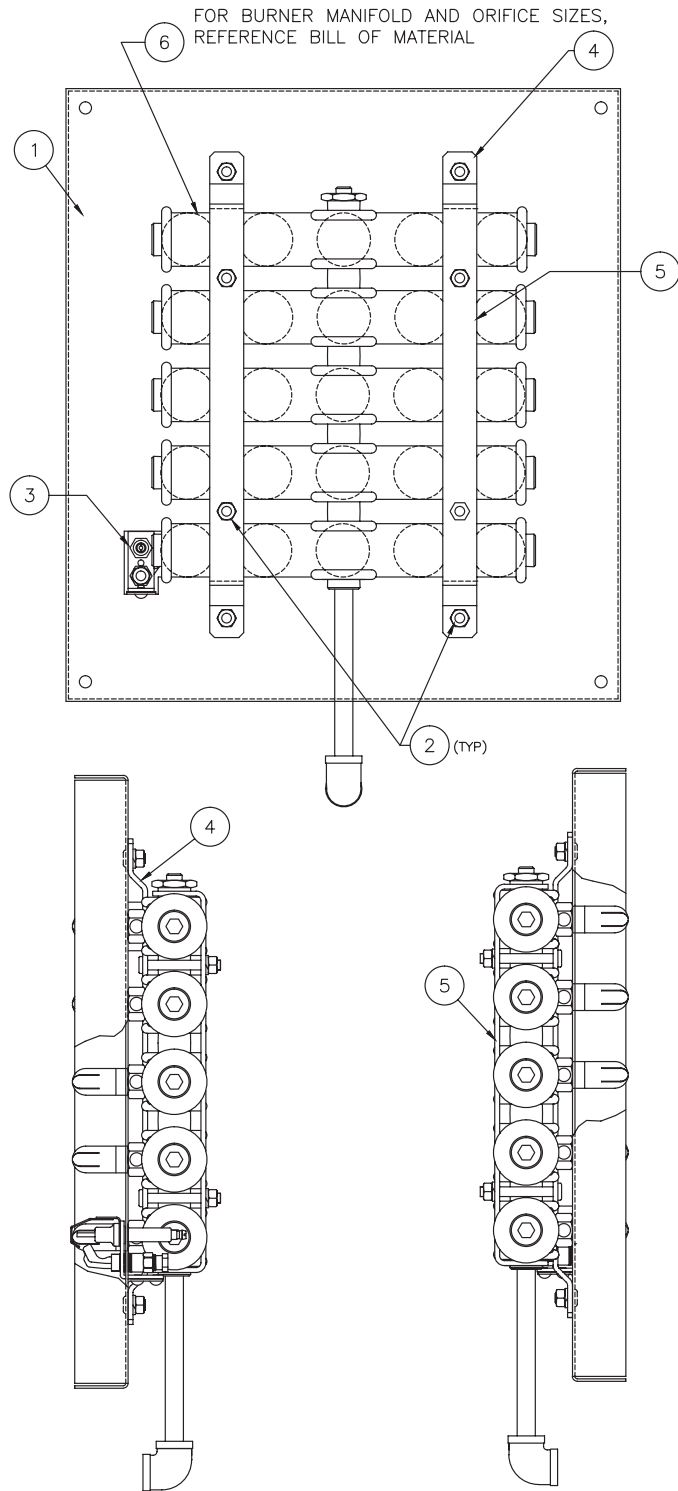

Parts List

GAS VALVE AND PIPING ASSEMBLY

Key	Description	Part #
1	TUBE, SOFT COPPER, 1/2 OD, 2" LONG	Z007334
3	THERMOSTAT, ELECTRIC	Z009730
4	ELBOW, 90 DEG, 1/2 NPT	Z008747
5	NIPPLE, 1/2 NPT, 2-1/2" LONG	Z005552
6	PROBE, LOW WATER LEVEL	Z079811
7	ELBOW, 90 DEG, 3/8 NPT	Z055335
8	FITTING, COMPRESSION, 1/2 TUBE TO 1/4 NPT (F)	Z097074
9	SWITCH, PRESSURE, 1/4 NPT	Z096963
10	FITTING, COMPRESSION, 5/8 TUBE TO 1/2 NPT (M)	Z049093
11	VALVE, GAS	123815
12	BRACKET, SUPPORT	Z065382
13	SCREW, TRUSS HEAD, 8-32, 3/8" LONG	Z005764
14	NUT, HEX SERRATED, 1/4-20	NT1101
16	BAR	Z005440
17	CLAMP, RIGID CONDUIT	Z068687
20	COVER, BOTTOM	Z090630
21	CAP, BOTTOM COVER PLATE	Z049803
22	GASKET, BOTTOM PLATE	Z007937
23	SCREW, CAP, WASHER HEAD, SLOTTED, 10-32, 3/8" LONG	Z002962
24	FITTING, COMPRESSION, 90 DEG, 1/4 TUBE TO 1/8 NPT (M)	Z004584
25	TUBE, ALUMINUM, 1/4 OD, 20" LONG	Z006796
26	CHAMBER, COMBUSTION	122094
-	COUPLING, FULL, 1/2 NPT	Z005722
-	FITTING, COMPRESSION, 5/8 TUBE TO 1/2 NPT (F)	Z049094
-	TUBE, GAS PIPING, TAKE UP SIDE	145041
-	TUBE, GAS PIPING, SUPPLY SIDE	145042
-	NIPPLE, 1/2 NPT, 3-1/2" LONG	Z008227
-	NIPPLE, 1/2 NPT, 3" LONG	Z005553
-	NIPPLE, 1/2 NPT, 12" LONG	Z005600
-	ELBOW, 90 DEG, UNION, 1/2 NPT	Z005495
-	NIPPLE, 1/2 NPT, 9.5" LONG	144360
-	NIPPLE, 1/2 NPT, 8" LONG	Z005557
-	SCREW, ROUND HEAD, 6-32, 1/2" LONG	Z012603

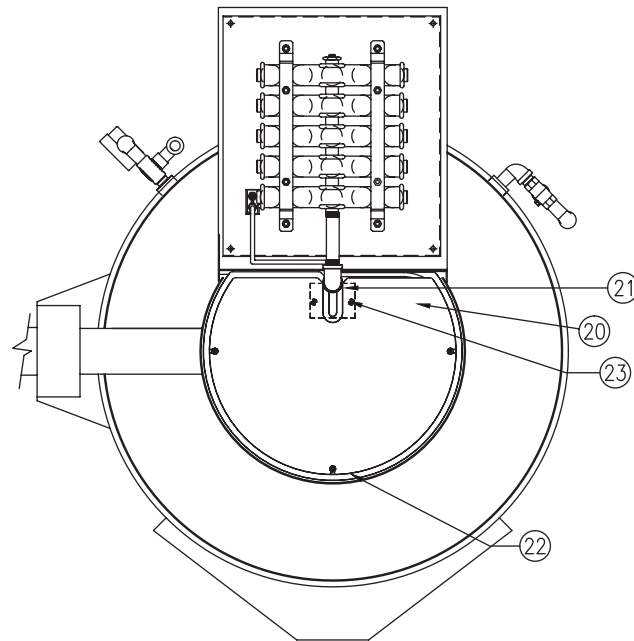
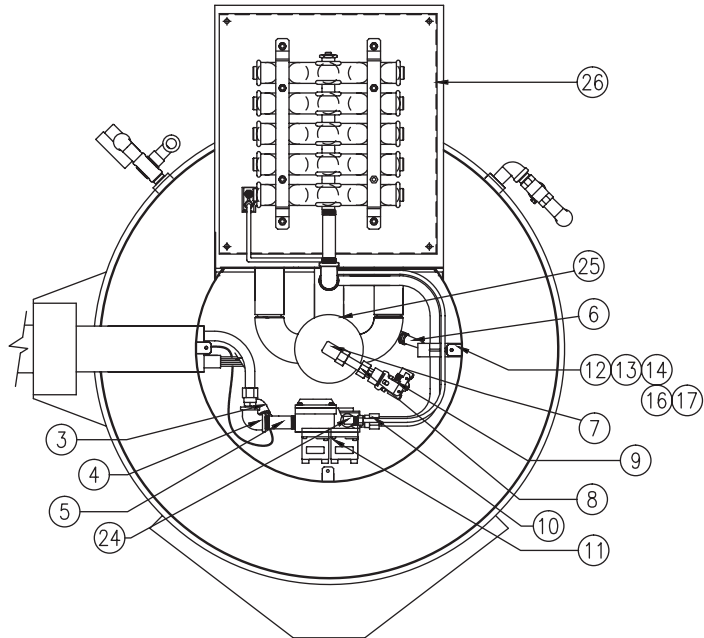

Parts List

KETTLE BODY ASSEMBLIES / 2" TDO KIT

Key	Description	Part #
1	LABEL, TDO VALVE CAUTION	110156
2	STEM, VALVE	Z009048
3	BONNET	Z009047
5	NUT, HEX	Z009354
6	HANDLE	Z009029
7	KBA & TRUNNION, NO TDO	143152
8	KBA & TRUNNION, 2" TDO	143150
-	1/4" PERFORATED DISK STRAINER 2" TDO	Z009044
-	NUT, WING, 10-24	Z009028
-	O-RING	Z009034

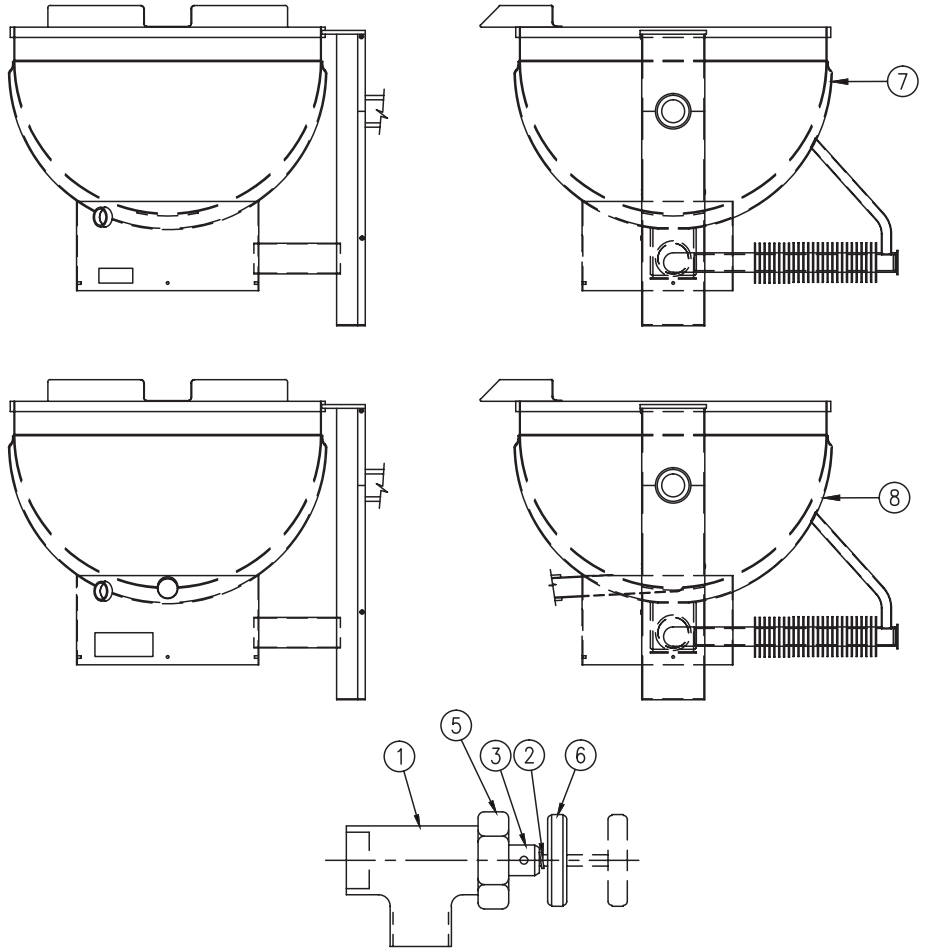

DHS(T)-40 WIRING DIAGRAM

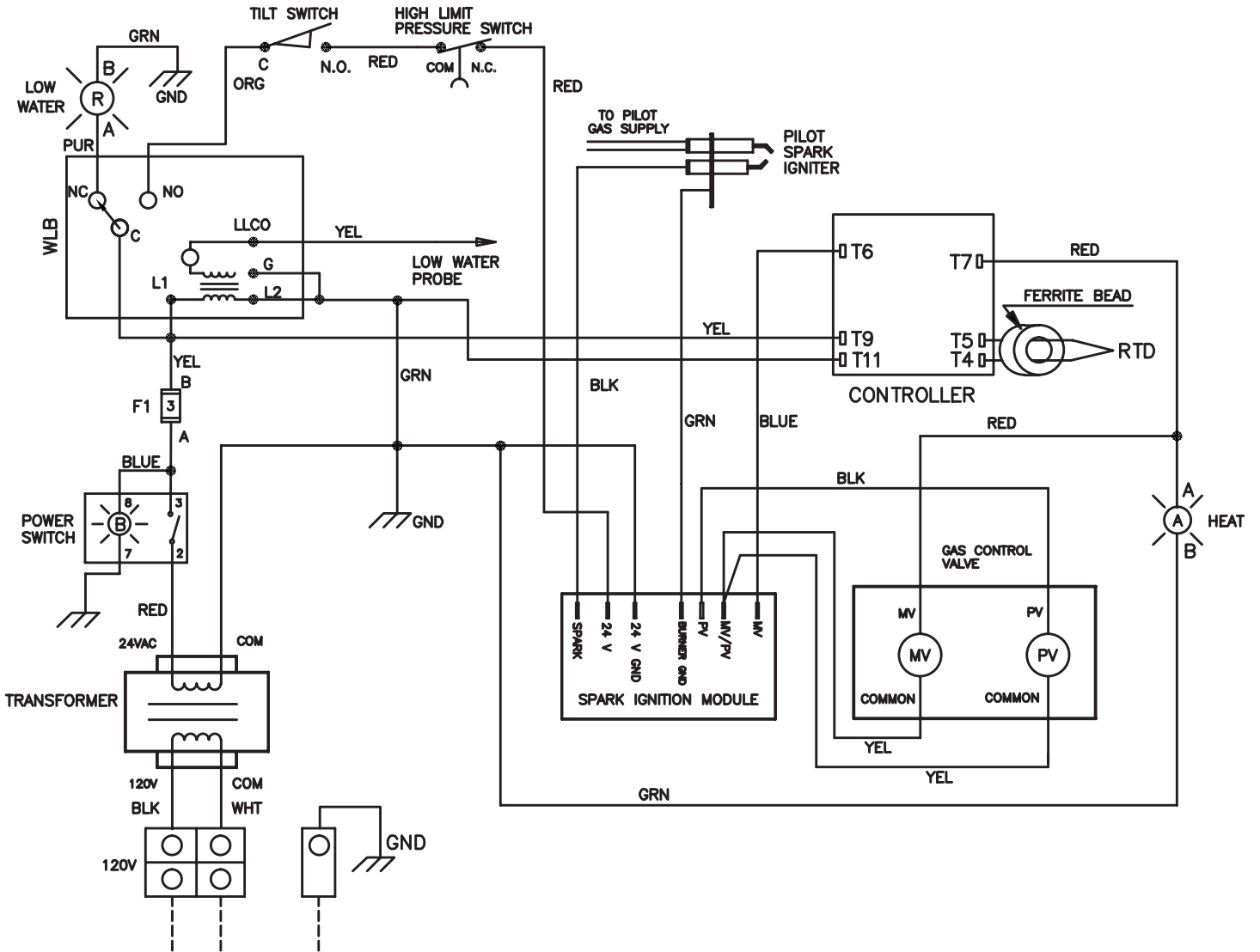

P/N 174753 REV. B

DHS(T)-40 WIRING DIAGRAM

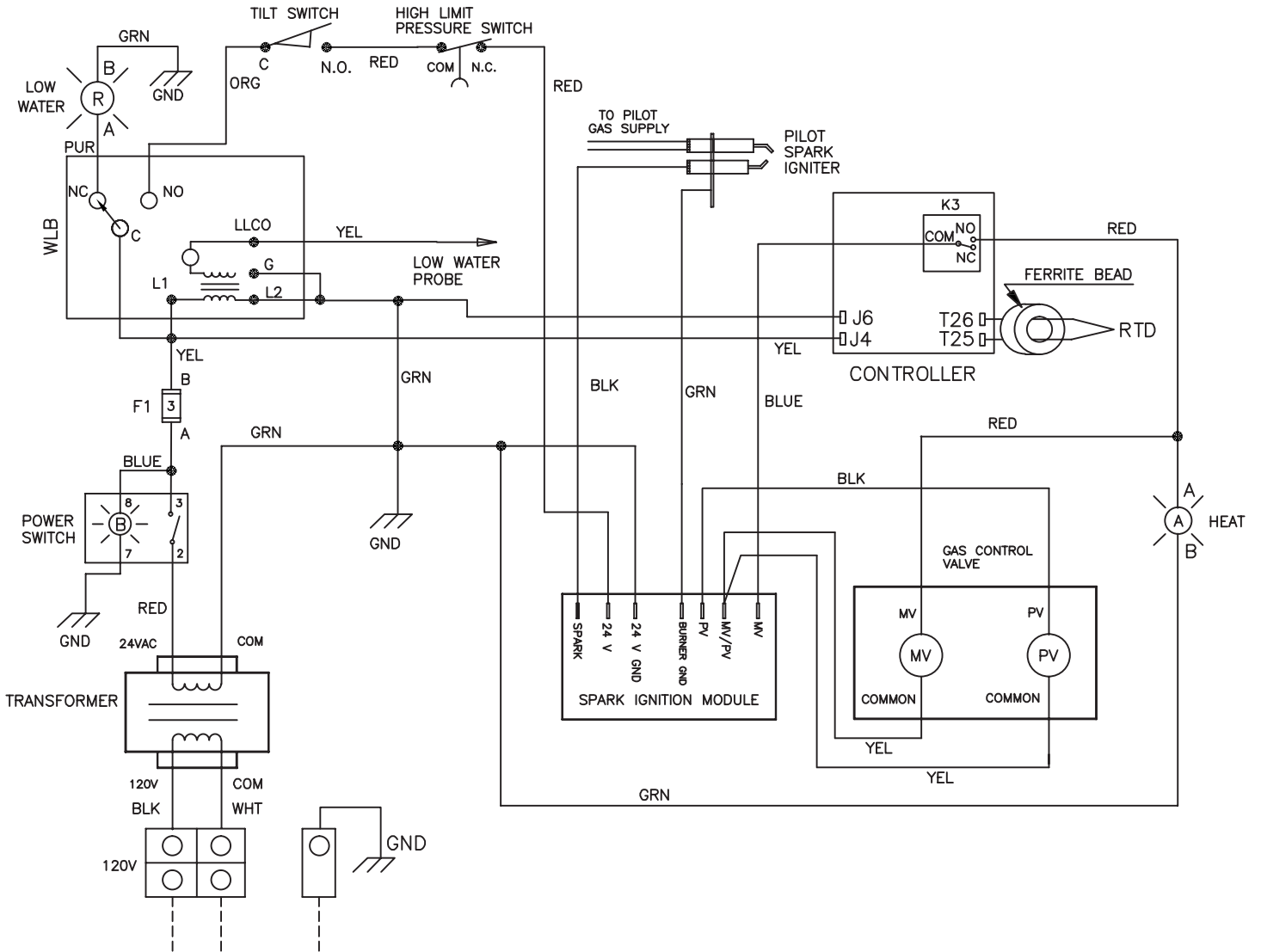

P/N 174754 REV. B

DHS(T)-40 WIRING DIAGRAM

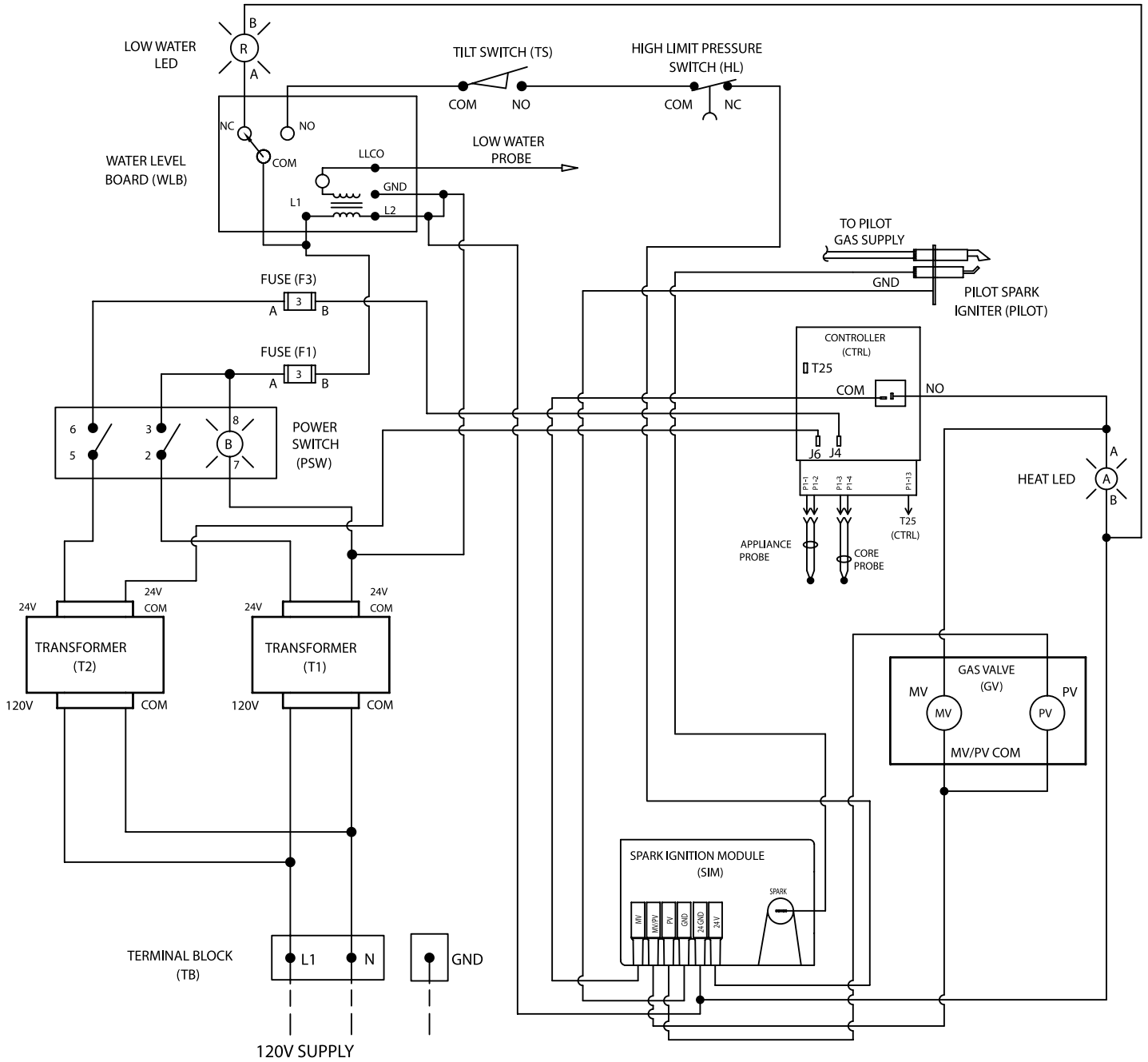

DH & TDH, 120V, C2T
P/N 176928 REV. A

