



OPERATOR MANUAL

IMPORTANT INFORMATION, KEEP FOR OPERATOR

888-994-7636, fax 888-864-7636
unifiedbrands.net

THIS MANUAL MUST BE RETAINED FOR FUTURE REFERENCE. READ, UNDERSTAND AND FOLLOW THE INSTRUCTIONS AND WARNINGS CONTAINED IN THIS MANUAL.

FOR YOUR SAFETY Instructions to be followed in the event user smells gas. This information shall be obtained by consulting your local gas supplier. As a minimum, turn off the gas and call your gas company and your authorized service agent. Evacuate all personnel from the area.

WARNING Improper installation, adjustment, alteration, service or maintenance can cause property damage, injury or death. Read the installation, operating and maintenance instructions thoroughly before installing or servicing this equipment.

NOTIFY CARRIER OF DAMAGE AT ONCE It is the responsibility of the consignee to inspect the container upon receipt of same and to determine the possibility of any damage, including concealed damage. Groen suggests that if you are suspicious of damage to make a notation on the delivery receipt. It will be the responsibility of the consignee to file a claim with the carrier. We recommend that you do so at once.

Manufacture Service/Questions 888-994-7636.

This manual provides information for:

STEAM JACKETED KETTLE WITH STANDARD ELECTRONIC IGNITION

MODELS DH(T)-20/40/60/80 & DH(T)-20/40/60/80(C,A) DOMESTIC & CE

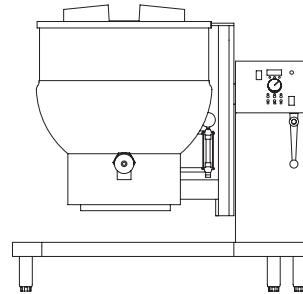

REFERENCES

CSA INTERNATIONAL
8501 East Pleasant Valley Road
Cleveland, Ohio 44131

NATIONAL SANITATION FOUNDATION
3475 Plymouth Road
Ann Arbor, Michigan 48106

KLENZADE SALES CENTER ECOLAB, Inc.
370 Wabasha
St. Paul, Minnesota 55102

ZEP MANUFACTURING COMPANY
1310-T Seaboard Industrial Boulevard
Atlanta, Georgia 30318

AMERICAN NATIONAL STANDARDS INST., Inc.
1430 Broadway
New York, New York 10018

Z223.1-1984 - National Fuel Gas Code
Z21.30 - Installation Gas Appliances & Piping

NATIONAL FIRE PROTECTION ASSOCIATION
60 Battery march Park
Quincy, Massachusetts 02269

NFPA/54 -Installation Gas Appliances & Piping
NFPA/70 - The National Electric Code

EQUIPMENT DESCRIPTION

The Groen DH is a floor-mounted, tilting, steam jacketed kettle with a thermostatically or electronically controlled, self-contained, gas-heated steam source and appropriate controls, mounted on a sturdy base. The Model DH is available in 20, 40, 60 or 80 gallon capacities.

The body of the DH Kettle is constructed of stainless steel, welded into one solid piece. The kettle is furnished with a reinforced rim and a butterfly shaped pouring lip. It has a steam jacket which is ASME shop inspected and registered with the national board for working pressures up to 50 PSI, 3.45 bars. Kettle finish is 180 emery grit on the inside and bright high buff polish on the outside.

The kettle is tilted with a hand crank to pour out its contents. Stainless steel panels enclose the controls and the base. Four stainless steel tubular legs support the unit. Bullet or flanged feet on each of the legs can be adjusted to level the kettle. Standard DHT units include a two inch tangent draw-off valve.

The self-contained steam source is heated by propane or natural gas. Ignition is electronic.

The kettle is charged at the factory with chemically pure water which contains rust inhibitors. The steam source provides kettle temperatures of 150° to approximately 295°F (65 to 150°C). Unit controls include a thermostat or controller, pressure gauge, safety valve, pressure limit control, low water cut-

off, power switch and gas regulator valve. The gas supply shuts off automatically when the kettle is tilted.

The unit must be specified for use with natural or propane gas. Service connections for gas and electricity are required. Standard power supply is 115 Volt (domestic) or 230V (CE). Alternate single-phase voltages (208-240V) are available.

KETTLE DIMENSIONS				
	DH/DHT-20	DH/DHT-40	DH/DHT-60	DH/DHT-80
Kettle Capacity	20 gal. (75 ltr)	40 gal. (150 ltr)	60 gal. (225 ltr)	80 gal. (302 ltr)
Kettle Body Diameter	20 in. (508 mm)	26 in. (660 mcm)	30 in. (762 mm)	34 in. (863 mm)
Base Width	35 in. (889 mm)	47 in. (1194 mm)	47 in. (1194 mm)	52 in. (1320 mm)
Base Front to Back	29 in. (736 mm)	29 in. (736 mm)	29 in. (736 mm)	37.5 in. (952 mm)



Information contained in this document is known to be current and accurate at the time of printing/creation. Reference our product line website for the most updated product information and specifications. © 2023 Electrolux Professional, Inc. All Rights Reserved.

IMPORTANT - READ FIRST - IMPORTANT

IMPORTANT: THESE APPLIANCES MUST BE INSTALLED BY A COMPETENT PERSON IN CONFORMITY WITH THE INSTALLATION AND SERVICING INSTRUCTIONS AND NATIONAL REGULATIONS IN FORCE AT THE TIME. PARTICULAR ATTENTION MUST BE PAID TO THE FOLLOWING (CE):

I. E. E. REGULATIONS FOR ELECTRICAL INSTALLATIONS

ELECTRICITY AT WORK REGULATIONS

GAS SAFETY (INSTALLATION & USE REGULATIONS

HEALTH AND SAFETY AT WORK ACT

FIRE PRECAUTIONS ACT

LOCAL AND NATIONAL BUILDING REGULATIONS

DETAILED RECOMMENDATIONS ARE CONTAINED IN INSTITUTE OF GAS ENGINEERS PUBLISHED DOCUMENTS: IGE/UP/1, IGE/UP/2, BS6173 AND BS5440 (CE).

THESE APPLIANCES HAVE BEEN CE-MARKED ON THE BASIS OF COMPLIANCE WITH THE GAS APPLIANCE DIRECTIVE, EMC AND LOW VOLTAGE DIRECTIVE FOR THE COUNTRIES, GAS TYPES AND PRESSURES AS STATED ON THE DATA PLATE.

WARNING: TO PREVENT SHOCKS, ALL APPLIANCES WHETHER GAS OR ELECTRIC, MUST BE EARTHED.

ON COMPLETION OF THE INSTALLATION, THESE INSTRUCTIONS SHOULD BE LEFT WITH THE ENGINEER-IN-CHARGE FOR REFERENCE DURING SERVICING. FURTHER TO THIS, THE USERS INSTRUCTIONS SHOULD BE HANDED TO THE USERS AND THE INSTALLER SHOULD INSTRUCT THE RESPONSIBLE PERSON(S) IN THE CORRECT OPERATION AND MAINTENANCE OF THE APPLIANCE. EMPHASIS SHOULD BE MADE WITH REGARD TO SAFE OPERATION OF DRAIN VALVE.

IT IS MOST IMPORTANT THAT THESE INSTRUCTIONS BE CONSULTED BEFORE INSTALLING AND COMMISSIONING THE APPLIANCE. FAILURE TO COMPLY WITH THE SPECIFIED PROCEDURES MAY RESULT IN DAMAGE OR THE NEED FOR A SERVICE CALL.

CAUTION: SHIPPING STRAPS ARE UNDER TENSION AND CAN SNAP BACK WHEN CUT.

WARNING: DISCONNECT POWER BEFORE SERVICING. FAILURE TO DISCONNECT COULD RESULT IN ELECTROCUTION AND DEATH.

CAUTION: UNIT WEIGHS 535 TO 973 LB. (245 TO 400 KG). FOR SAFE HANDLING, INSTALLER SHOULD OBTAIN HELP AS NEEDED, OR EMPLOY APPROPRIATE MATERIALS HANDLING EQUIPMENT (SUCH AS A FORKLIFT, DOLLY, OR PALLET JACK) TO REMOVE THE UNIT FROM THE SKID AND MOVE IT TO THE PLACE OF INSTALLATION.

WARNING: INSTALLATION OF THE KETTLE MUST BE DONE BY PERSONNEL QUALIFIED TO WORK WITH GAS AND ELECTRICITY. IMPROPER INSTALLATION CAN RESULT IN INJURY TO PERSONNEL AND/OR DAMAGE TO EQUIPMENT.

WARNING: THIS UNIT IS DESIGNED FOR COMMERCIAL USE. NEVER USE HOME OR RESIDENTIAL GRADE GAS CONNECTIONS. THEY DO NOT MEET COMMERCIAL GAS CODES AND COULD BE HAZARDOUS.

DANGER: ELECTRICALLY GROUND THE UNIT AT THE TERMINAL PROVIDED. FAILURE TO GROUND UNIT COULD RESULT IN ELECTROCUTION AND DEATH.

WARNING: DO NOT CONNECT ANY PIPING TO THE POP SAFETY VALVE, THE VALVE MUST BE FREE TO VENT STEAM AS NEEDED. THE ELBOW ATTACHED TO THE SAFETY VALVE SHOULD POINT TO THE FLOOR. IMPROPER INSTALLATION WILL VOID WARRANTY.

WARNING: FAILURE TO CHECK SAFETY VALVE OPERATION PERIODICALLY COULD RESULT IN PERSONAL INJURY AND/OR DAMAGE TO EQUIPMENT.

WARNING: WHEN TESTING SAFETY VALVE, AVOID ANY EXPOSURE TO THE STEAM BLOWING OUT OF THE SAFETY VALVE. DIRECT CONTACT WITH STEAM COULD RESULT IN SEVER BURNS.

WARNING: KEEP THE APPLIANCE AREA FREE AND CLEAR OF COMBUSTIBLE MATERIALS. FAILURE TO DO SO COULD RESULT IN FIRE OR PROPERTY DAMAGE.

CAUTION: BE SURE ALL OPERATORS READ, UNDERSTAND AND FOLLOW THE OPERATING INSTRUCTIONS, CAUTIONS AND SAFETY INSTRUCTIONS CONTAINED IN THIS MANUAL.

CAUTION: KEEP FLOORS IN KETTLE WORK AREA CLEAN AND DRY. IF SPILLS OCCUR, CLEAN IMMEDIATELY TO AVOID THE DANGER OF SLIPS OR FALLS.

WARNING: WHEN TILTING KETTLE FOR PRODUCT TRANSFER:

1) USE CONTAINER DEEP ENOUGH TO CONTAIN AND MINIMIZE PRODUCT SPLASHING.

2) PLACE CONTAINER ON STABLE, FLAT SURFACE, AS CLOSE TO KETTLE AS POSSIBLE.

3) STAND TO SIDE OF KETTLE WHILE POURING — NOT DIRECTLY IN POUR PATH OF HOT CONTENTS.

4) RETURN KETTLE BODY TO LEVEL POSITION AFTER CONTAINER IS FILLED OR TRANSFER IS COMPLETE.

5) DO NOT OVERFILL CONTAINER, AVOIDING DIRECT SKIN CONTACT WITH HOT CONTAINER AND ITS CONTENTS.

WARNING: DO NOT HEAT AN EMPTY KETTLE. EXCESSIVE STEAM PRESSURE COULD DEVELOP.

WARNING: IF THE KETTLE CONTAINS ITEMS IN HOT LIQUIDS SUCH AS SAUCE OR MELTED FAT, THEY CAN SLIDE FORWARD SUDDENLY DURING TILTING AND CAUSE THE HOT LIQUID TO SPLASH OUT.

WARNING: AVOID ALL DIRECT CONTACT WITH HOT FOOD PRODUCT OR WATER IN THE KETTLE. DIRECT CONTACT COULD RESULT IN SEVERE BURNS.

CAUTION: DO NOT OVER FILL THE KETTLE WHEN COOKING, HOLDING OR CLEANING. KEEP LIQUIDS A MINIMUM OF 2-3" (5-8 CM) BELOW THE KETTLE BODY RIM TO ALLOW CLEARANCE FOR STIRRING, BOILING AND SAFE PRODUCT TRANSFER.

WARNING: IT IS RECOMMENDED THAT WATER AND SOLUTIONS BE KEPT OUT OF CONTROLS AND BURNERS. DO NOT USE HIGH PRESSURE SPRAY DIRECTLY ON THE CONTROL CONSOLE, ELECTRICAL CONNECTIONS AND BURNERS. USE A GARDEN HOSE SPRAY CONNECTED TO CITY WATER SUPPLY.

CAUTION: MOST CLEANERS ARE HARMFUL TO THE SKIN, EYES, MUCOUS MEMBRANES AND CLOTHING. PRECAUTIONS SHOULD BE TAKEN TO WEAR RUBBER GLOVES, GOGGLES OR FACE SHIELD AND PROTECTIVE CLOTHING. CAREFULLY READ THE WARNINGS AND FOLLOW THE DIRECTIONS ON THE LABEL OF THE CLEANER TO BE USED. FAILURE TO DISCONNECT COULD RESULT IN ELECTROCUTION AND DEATH.

WARNING: BEFORE REPLACING ANY PARTS, DISCONNECT THE UNIT FROM THE ELECTRIC POWER SUPPLY AND CLOSE THE MAIN GAS COCK. ALLOW FIVE MINUTES FOR UNBURNED GAS TO VENT.

CAUTION: USE OF ANY REPLACEMENT PARTS OTHER THAN THOSE SUPPLIED BY AUTHORIZED DISTRIBUTORS CAN CAUSE INJURY TO THE OPERATOR AND DAMAGE TO THE EQUIPMENT AND WILL VOID ALL WARRANTIES.

IMPORTANT: SERVICE PERFORMED BY OTHER THAN GROEN AUTHORIZED SERVICE AGENT WILL VOID ALL WARRANTIES.

CAUTION: THIS APPLIANCE CAN BE USED BY CHILDREN AGED FROM 8 YEARS AND ABOVE AND PERSONS WITH REDUCED PHYSICAL, SENSORY OR MENTAL CAPABILITIES OR LACK OF EXPERIENCE AND KNOWLEDGE IF THEY HAVE BEEN GIVEN SUPERVISION OR INSTRUCTION CONCERNING USE OF THE APPLIANCE IN A SAFE WAY AND UNDERSTAND THE HAZARDS INVOLVED.

CAUTION: CHILDREN SUPERVISED ARE NOT TO PLAY WITH THIS APPLIANCE.

CAUTION: CLEANING AND USER MAINTENANCE SHALL NOT BE MADE BY CHILDREN WITHOUT SUPERVISION.

CAUTION: FOR APPLIANCES INTENDED FOR USE AT ALTITUDES EXCEEDING 2,000 M, THE MAXIMUM ALTITUDE WILL BE STATED OR MARKED ON APPLIANCE.

Available Options:

1. 2" (50.8 mm) tangent drawoff standard on DHT models
2. Strainers, solid disk, 1/4" (6.35mm) or 1/8" (3.18mm) holes
3. No. 31 lift-off cover
4. No. 51 counterbalanced cover w/actuator*
5. Basket Inserts (Tri-BC)
6. Water fill faucets with swing spout
7. Kettle Brush Kit

PERFORMANCE DATA (DOMESTIC)

Model	DH/DHT-20	DH/DHT-40	DH/DHT-60	DH/DHT-80
BTU/hr	72,000	100,000	150,000	150,000
kW	21.1	29.3	44.0	44.0

PERFORMANCE DATA (CE)

Model	DH/DHT-20	DH/DHT-40	DH/DHT-60
(G20) kW	19.0	26.4	31.6
BTU/hr	64,800	89,900	107,900
(G31) kW	19.4	24.3	32.3
BTU/hr	66,200	82,700	110,300

INSPECTION & UNPACKING

CAUTION: SHIPPING STRAPS ARE UNDER TENSION AND CAN SNAP BACK WHEN CUT. TAKE CARE TO AVOID PERSONAL INJURY OR DAMAGE TO THE UNIT BY STAPLES LEFT IN THE WALLS OF THE CARTON.

CAUTION: THIS UNIT WEIGHS BETWEEN 535 AND 978 POUNDS (245 TO 400 KG) DEPENDING ON SIZE. INSTALLER SHOULD USE PROPER EQUIPMENT TO LIFT SAFELY.

The unit will arrive in a heavy shipping carton and will be bolted or banded to a skid. Immediately upon receipt, inspect the carton carefully for exterior damage. Carefully cut any polyester straps around the carton and detach the sides of the box from the skid. Pull the carton up off the unit. Thoroughly inspect the unit for hidden damage. Report any shipping damage or incorrect shipments to the delivery agent.

Write down the model number, serial number, and installation date, and retain this information for future reference. Space for these entries is provided at the top of the Service Log at the back of this manual. Keep this manual on file and available for operators to use.

When installation is to begin, carefully cut any straps which hold the unit on the skid. Lift the unit straight up off the skid. Examine packing materials to be sure loose parts are not discarded with the materials.

INSTALLATION

DOMESTIC

WARNING: THE UNIT MUST BE INSTALLED BY PERSONNEL WHO ARE QUALIFIED TO WORK WITH GAS, ELECTRICITY AND PLUMBING. IMPROPER INSTALLATION CAN CAUSE INJURY TO PERSONNEL AND/OR DAMAGE TO THE EQUIPMENT. THE UNIT MUST BE INSTALLED IN ACCORDANCE WITH APPLICABLE CODES. THE UNIT MUST BE INSTALLED BY A LICENSED PLUMBER OR GAS FITTER WHEN INSTALLED WITHIN THE COMMONWEALTH OF MASSACHUSETTS.

DANGER: ELECTRICALLY GROUND THE UNIT AT THE TERMINAL PROVIDED. FAILURE TO GROUND UNIT COULD RESULT IN ELECTROCUTION AND DEATH.

WARNING: DO NOT CONNECT ANY PIPING TO THE PRESSURE RELIEF VALVE. THE VALVE MUST BE FREE TO VENT STEAM AS NEEDED. IMPROPER INSTALLATION WILL VOID THE WARRANTY! THE PRESSURE RELIEF VALVE MUST POINT TO THE FLOOR.

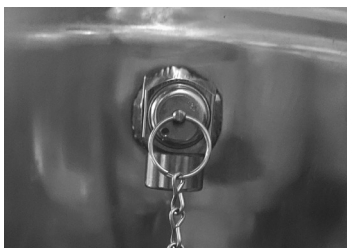

The open end of the pressure relief valve must face downward.

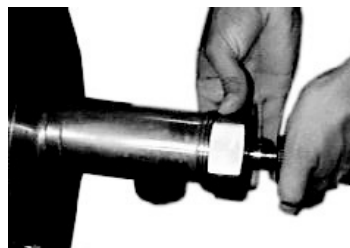

When attaching the draw-off valve, hand-tighten the nut.

For efficient performance the DH kettle must be installed in a well-ventilated

area. Items which might restrict or obstruct the flow of air for combustion and ventilation must be removed. The area directly around the appliance must be free of combustible materials.

1. Installation can be on a combustible or noncombustible floor. Clearances should be per table below.

	MINIMUM CLEARANCE FROM COMBUSTIBLE WALLS	MINIMUM CLEARANCE FROM NON-COMBUSTIBLE WALLS	RECOMMENDED CLEARANCES
Left Side	6 in.	0 in.	6 in.
Right Side	6 in.	0 in.	10 in.
Rear	10 in.	10 in.	12 in.

2. The kettle should be installed in an adequately ventilated room with provision for adequate air supply. The ventilation must employ a vent hood and exhaust fan with no direct connection between the vent duct and the kettle flue. Do not obstruct the flue or vent duct after installation.
3. Set the kettle in place and level it using a spirit level on the bar rim, by turning the bullet or flange feet to adjust leg length. Allow clearance around the unit for cleaning, maintenance and service.
4. Complete the piping to the gas service main with ½" line or approved equivalent.
5. Provide 115 vac, 60 Hz, single phase 5 AMP electrical service. The unit may also be ordered for alternate electric service of 208 VAC - 240 VAC. Observe local codes and/or The National Electrical Code in accordance with ANSI/NFPA 70 (current edition), or the Canadian Electrical Code, CSA C22.2 (current edition), as applicable. Use the wiring diagram inside the service panel and at the rear of this manual.
6. Bring electrical service through the entrance at the rear of the support housing with a ½ inch conduit connector. Make a watertight connection with the incoming lines.
7. Electrically ground the unit at the terminal provided.
8. After the kettle has been connected to the gas supply, check all gas joints for leaks. DO NOT USE FLAME TO CHECK FOR LEAKS. A thick soap solution or other suitable leak detector should be employed.
9. The gas supply and unit's installation must conform with local codes or in the absence of local codes, with the National Fuel Gas Code, ANSI Z223.1/NFPA 54 (current edition), or the Natural Gas and Propane Installation Code CSA 149.1(current edition), as applicable. Additionally following must be complied with: THE AREA DIRECTLY AROUND THE APPLIANCE MUST BE CLEARED OF ALL COMBUSTIBLE MATERIAL. FAILURE TO FOLLOW THESE INSTRUCTIONS CAN CAUSE BODILY INJURY AND /OR PROPERTY DAMAGE. The appliance and its individual shut-off valve must be disconnected from the gas supply piping system during any testing at pressures in excess of ½ PSI (3.45 kPa). The appliance must be isolated from the gas supply piping system by closing its individual manual shut-off valve during any pressure testing at or less than ½ PSI (3.45 kPa).
10. Confirm that the jacket water level is between the gauge glass markers or inside the sight glass port. If the level is low, follow instructions under "Jacket Filling and Water Treatment," Page 16.
11. The open end of the safety valve must face downward. If it does not, turn it to the correct position.
12. For units with optional tangent draw off: Assemble the tangent draw-off by placing the large nut over the draw-off valve and inserting it into the draw-off tube. ONLY HAND-TIGHTEN THE NUT to complete installation.

WARNING: THE UNIT MUST BE INSTALLED BY PERSONNEL QUALIFIED TO WORK WITH ELECTRICITY AND GAS. IMPROPER INSTALLATION CAN CAUSE INJURY TO PERSONNEL AND/OR DAMAGE TO EQUIPMENT. THE UNIT MUST BE INSTALLED IN ACCORDANCE WITH ALL APPLICABLE CODES.

CAUTION: THE APPLIANCE FLUE DISCHARGES VERTICALLY FROM THE TOP OF THE UNIT AT THE REAR. IT MUST NOT BE DIRECTLY CONNECTED TO ANY FLUE, MECHANICAL EXTRACTION SYSTEM, OR DUCTING LEADING OUTSIDE THE BUILDING. THE APPLIANCE IS BEST DISCHARGED UNDER AN OPEN CANOPY WHICH CONNECTS WITH A VENTILATING SYSTEM.

WARNING: THIS APPLIANCE MUST BE EARTHED.

UNLESS OTHERWISE STATED, PARTS WHICH HAVE BEEN PROTECTED BY THE MANUFACTURER ARE NOT TO BE ADJUSTED BY THE INSTALLER.

Model	DH/DHT-20	DH/DHT-40	DH/DHT-60
Width mm (inch)	890 (34.9)	1190 (46.8)	1190 (46.8)
Depth mm (inch)	790 (31.0)	930 (36.5)	990 (38.9)
Height mm (inch)	1040 (40.9)	1150 (45.2)	1240 (48.7)
Weight kg (lbs)	240 (530)	290 (640)	370 (810)

SITING

The appliance should be installed on a level floor in a well lit and draught free position. The installation of the appliance must be executed in accordance with local and/or national regulations as listed in this manual.

CLEARANCES

Minimum clearances of 150 mm (6 in) from the sides of the appliance and 250 mm (10 in) from the rear of the appliance are required if the appliance is installed next to combustible surfaces. A vertical clearance of 750 mm (30 in) minimum should be allowed between the top rim of kettle and any overlying surface.

VENTILATION

The unit must be installed in an adequately ventilated room with a provision for adequate air supply to the unit. The area directly around the appliance must be cleared of all combustible material. For multiple installations, the requirements for individual appliances should be added together. Installation should be made in accordance with local and / or national regulations applying at the time. A competent installer must be employed.

Recommendations for ventilation for catering appliances are given in BS 5440:2 and are shown in the table below.

Equipment (unit type)	Ventilation Rate Required	
	m3/min	ft3/ min
Range	17	600
Pastry Oven	17	600
Fryer	26	900
Grill	17	600
Steak Grill	26	900
Boiling Pan	17	600
Steamer	17	600
Sterilizing Sink	14	500
Bains Marie	11	400
Tea/Coffee Machine	8.5-14	300-500

ELECTRICAL SUPPLY

This unit is designed for connection to fixed wiring. A suitably rated isolating switch with contact separation of at least 3 mm (0.12 in) on both poles must be fitted to the installation and the wiring executed in accordance with the regulations listed in this manual. Cable entry is at the lower rear on the right side of the appliance. Access is gained by removing relevant panels as described in Servicing and Conversion section. Provide 230 VAC, 50 Hz, 1 Phase, 1 AMP or 40 Watts service.

The electrical schematic is in the service compartment and this manual.

GAS SUPPLY

Incoming service must be of sufficient size to supply full rate without excessive pressure drop. A gas meter is connected to the service pipe by the Gas Supplier. Any existing meter should be checked by the Gas Supplier to ensure that it has capacity to pass the required rate of gas for the kettle in addition to other installed gas equipment.

The appliance governor is incorporated in the gas control valve which is in the control cabinet. The control valve governor is suitable for both natural and propane gases without conversion.

Installation pipe work should be fitted in accordance with IEGE/UP/2. The pipe work should not be smaller than the gas inlet connection on the kettle, i.e. Rp ½ (½" B.S.P.)

An isolating cock must be located near the appliance to allow shut down during emergency or servicing. Test for gas soundness and purged as specified in IGE/UP/1.

Natural (G20) Models	kW	BTU/hr
DH-20	19.0	64,800
DH/1-40	26.4	89,900
DH-60	31.6	107,900
Propane (G31) Models	kW	BTU/hr
DH-20	19.4	66,200
DH/1-40	24.3	82,700
DH-60	32.3	110,300

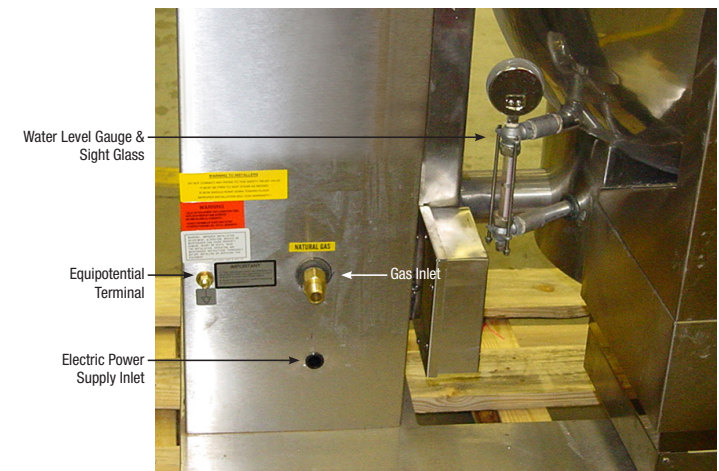

Gas and Electrical Connections are made at the rear of the unit.

Model	# of Injectors	Natural (G20)	Propane (G31)
DH-20	15	1.10 mm	0.65 mm
DH/1-40	20	1.15 mm	0.65 mm
DH-60	25	1.10 mm	0.65 mm

NOTE: With reference to gas rate, pressure adjustments and conversions, this appliance is CE-approved for use with the following gases:

1. G20 natural gas may be supplied to the appliance in Austria, Denmark, Finland, Greece, Iceland, Ireland, Italy, Luxembourg, Norway, Portugal, Spain, Sweden, Switzerland and the United Kingdom.
2. G31 propane gas may be supplied to the appliance in Germany, Ireland, the Netherlands, Portugal, Spain, Switzerland, and the United Kingdom.

Use of the appliance with non-approved gases in a listed country, or use in other countries, will void CE certification.

A pressure test point is fitted on the burner manifold and on the gas control valve.

Natural (G20) Models	mBar	WCI (Water Column Inches)
DH-20	8.75	3.5
DH/1-40	8.75	3.5
DH-60	8.75	3.5
Propane (G31) Models	mBar	WCI (Water Column Inches)
DH-20	25	10.0
DH/1-40	25	10.0
DH-60	25	10.0

BURNER ADJUSTMENT

The burners are fixed aeration type and have no provision for adjustment of air inlet.

INITIAL START-UP

CAUTION: ENSURE THAT THE KETTLE CONTAINS LIQUID WHEN THE BURNERS ARE ALIGHT.

WARNING: THIS APPLIANCE MUST BE EARTHED.

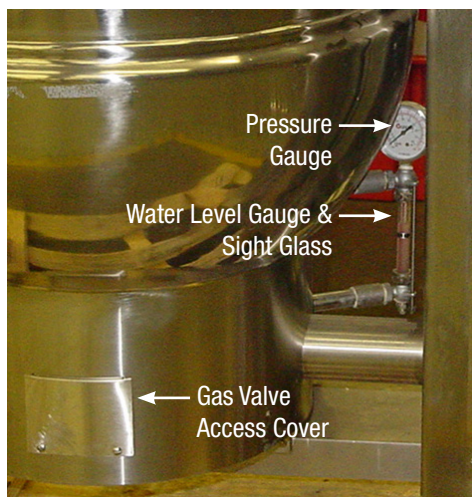

GAS SUPPLY

Connect the unit to the gas supply and test for gas soundness. For gas supply down stream of the gas valve, leak detection spray or soap solution may be used with the burners lit.

ELECTRICAL SUPPLY

Before commissioning the appliance, ensure that the electrical installation has been carried out to the relevant regulations (see Installation section).

JACKET WATER LEVEL/JACKET PRESSURE

Ensure the water level in the jacket is correct, by confirming that it is between the sight glass marks. If it is low, follow instructions in Servicing and Conversion section, Jacket Filling.

Check the pressure gauge. If it does not show 20 or more inches of vacuum (that is, a reading of 20 to 30 below zero) see Servicing and Conversion section, Jacket Vacuum.

PRE-COMMISSIONING CHECK

1. Prior to operation, clean out kettle thoroughly using hot water and detergent. Rinse kettle thoroughly.
2. Remove all literature and packing materials from the interior and exterior of the unit.
3. Ensure the open end or the elbow at the outlet of the safety valve is directed down. If not, turn the elbow to the correct position. See detailed Instructions in Servicing and Conversion section for Safety Valve installation and operation.

START-UP

Now that your kettle has been installed, you should test it to ensure that the unit is operating correctly.

1. Remove literature and packing materials from the interior and exterior of the unit.
2. Put a small amount of water into the kettle (6 to 13 mm). With the kettle in the horizontal position, note how the water lies in the kettle, to confirm that the pan was leveled properly during installation.
3. Following the "To Start Pan" instructions for your kettle model, begin heating the water at a temperature setting of 235°F (113°C). At this setting, heating should continue until the water boils.
4. To shut down the unit, switch the power switch to OFF.
5. Turn the tilting handwheel counterclockwise to pour out the water and to confirm that the kettle body can be tilted smoothly from horizontal to vertical.

If the unit functions as described above, it is ready for use. If it does not, contact your local Authorized Service Agency (Domestic) or Engineer (CE).

After installing and commissioning the appliance, the user's instructions should be handed to the user or purchaser. Ensure that the instructions for lighting, turning off, correct use and cleaning are properly understood. The location of the main gas isolating valve should be emphasized and the emergency shut down procedure should be demonstrated.

SETTING THE GAS PRESSURE

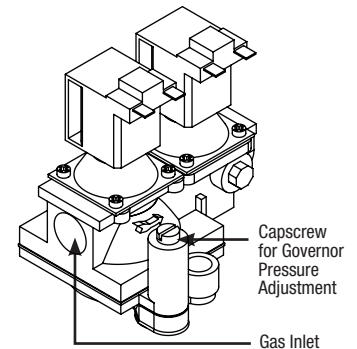
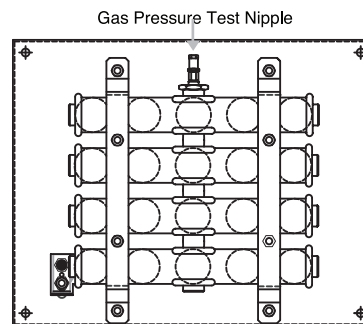

1. It is necessary to check the gas pressure during commissioning. A pressure gauge must be connected to the pressure test point on the gas manifold. See above figure for test points.
2. Turn the main gas and electricity supply on.
3. Light the burners.
4. Remove cover plate on the round skirt at bottom of kettle.
5. Remove governor cap screw from control valve. See above figure for position on valve.
6. Governor adjustment is suitable for both natural and propane gas.
7. To increase pressure turn the screw inside the governor turret clockwise; anti-clockwise to reduce pressure. Check the burner pressure again after 15 minutes operation and adjust if necessary.
8. Disconnect the pressure gauge from the test point. Re-seal the pressure test point and test for gas soundness.
9. Replace governor cap screw and replace cover plate.

CHECKING PERFORMANCE OF CONTROLS

1. Light the unit. Check that controls quickly and smoothly produce a healthy spark from the electrode to the earthing post.
2. Turn controller off and then on. Check that burners go out and reignite smoothly and quickly when switched back on. Repeat several times.
3. If the unit fails to respond as described, it should be serviced by an authorized Groen service agent.

OPERATION

WARNING: WHEN TILTING KETTLE:

- 1) WEAR PROTECTIVE OVEN MITT AND PROTECTIVE APRON.
- 2) USE DEEP CONTAINER TO CONTAIN AND MINIMIZE PRODUCT SPLASHING.
- 3) PLACE CONTAINER ON STABLE, FLAT SURFACE, AS CLOSE TO KETTLE AS POSSIBLE.
- 4) STAND TO RIGHT OF KETTLE WHILE POURING — NOT DIRECTLY IN POUR PATH OF HOT CONTENTS.
- 5) POUR SLOWLY, MAINTAINING CONTROL OF KETTLE, AND RETURN KETTLE BODY TO UPRIGHT POSITION AFTER CONTAINER IS FILLED OR TRANSFER IS COMPLETE.
- 6) DO NOT OVERFILL CONTAINER. AVOID SKIN CONTACT WITH HOT CONTAINER AND ITS CONTENTS.

WARNING: AVOID ALL DIRECT CONTACT WITH HOT SURFACES AND HOT FOOD OR WATER IN THE KETTLE. DIRECT CONTACT COULD RESULT IN SEVERE BURNS.

CAUTION: DO NOT TILT KETTLE WITH LIFT-OFF COVER IN PLACE. COVER MAY SLIDE OFF, CAUSING INJURY TO OPERATOR.

CAUTION: DO NOT OVERFILL THE KETTLE WHEN COOKING, HOLDING OR CLEANING. KEEP LIQUIDS AT LEAST 2-3" (5-8 CM) BELOW THE KETTLE RIM TO ALLOW CLEARANCE FOR STIRRING, BOILING AND SAFE PRODUCT TRANSFER.

WARNING: AVOID ALL DIRECT CONTACT WITH HOT FOOD OR WATER IN THE KETTLE. DIRECT CONTACT COULD RESULT IN SEVERE BURNS.

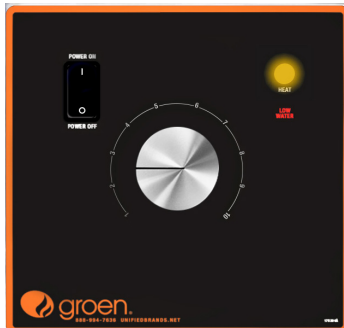

Classic Control



Advanced Control

CONTROLS - MODELS DH(T)-20, -40, -60, -80

1. The "Classic" Controls for the kettle are:

- a. The manual gas shut-off valve supplies inlet gas to the unit.
- b. Lighted Power ON switch located on the control console. Controls main power to the unit.
- c. The temperature knob, located on the control console, is used to set the kettle heat values between 1 and 10.
- d. Heating indicator light located on the control console, lights when the controller sends call to open the main gas valve and will cycle on and off once the unit reaches set temperature. If the unit is tilted, the main gas valve will be disabled and the light will turn off until the unit is returned to the cooking position.
- e. A LOW WATER indicator light, located on the control console, illuminates when the jacket water falls below acceptable levels. When lit, the main gas valve is disabled and will not function until the jacket water is refilled using the procedure in this manual.
- f. Crank tilt - a handle controls the worm and gear mechanism that smoothly tilts the kettle body and holds it in the desired position.

2. The "Advanced" Controls for the kettle are:

- a. The manual gas shut-off valve supplies inlet gas to the unit.
- b. Lighted Power ON switch located on the control console. Controls main power to the unit.
- c. The temperature knob, located on the control console, is used to set the kettle heat values between 1.0 and 10.0. The current setting will be reflected on the display.

- d. Heating indicator light located on the control console, lights when the controller sends call to open the main gas valve and will cycle on and off once the unit reaches set temperature. If the unit is tilted, the main gas valve will be disabled and the light will turn off until the unit is returned to the cooking position.
- e. A LOW WATER indicator light, located on the control console, illuminates when the jacket water falls below acceptable levels. When lit, the main gas valve is disabled and will not function until the jacket water is refilled using the procedure in this manual.
- f. SET TnNP Mode - Allows power to the controller and gas to the pilot without the kettle heating; the kettle will heat once the LOW TEMP, MANUAL or HIGH TEMP button is selected.
- g. LOW TEMP Button – Used to set operating temperature of the kettle at a preset low intensity (default = 2.0). Can be pressed at any time during operation of the unit to change the set temperature to the preset value except when there is an active TIMER enabled.
- h. MANUAL Mode button – Enables the user modify the desired cooking temperature of the kettle (between 1.0 and 10.0) using the temperature knob and display (default = 5.0). The operator will press the MANUAL button and set the desired temperature using the temperature knob and display. Once the desired intensity is displayed, the user may either press the MANUAL button again or wait 5 seconds and the set temperature will be accepted by the controller and locked in. After the set temperature is accepted, it may be changed at any time by pressing the MANUAL button and resetting the temperature using the same process above.
- i. HIGH TEMP button – Used to set operating temperature of the kettle at a preset high intensity (default = 7.0). Can be pressed at any time during operation of the unit to change the set temperature to the preset value except when there is an active TIMER enabled.

1. TIMER button - once the appropriate set temperature is selected using the HIGH TEMP, MANUAL or LOW TEMP buttons; a countdown timer can be set to remind the user when the cooking process is completed. Range – 1 minute to 10 hours
2. When the timer expires:
 - a. the set temperature will automatically change to the LOW TEMP setting and will continue at this setting until the user changes the temperature via MANUAL or HIGH TEMP buttons
 - b. An audible alarm will notify the user that attention is required, the alarm will continue to sound until the user presses the TIMER button.
3. An active timer can be cancelled by pressing and holding the TIMER button for 5 secs.
4. Set temp can be changed during an active timer by pressing the MANUAL button and adjusting the set temp using the Temperature knob and display.
5. HIGH TEMP and LOW TEMP presets cannot be used to change the setpoint once a TIMER has started.
- j. READY alarm – The control will sound 3 beeps when the unit has reached within 20 degrees of set point during pre-heat and when a higher set temperature is selected.
- k. Crank tilt - a handle controls the worm and gear mechanism that smoothly tilts the kettle body and holds it in the desired position.

OPERATING PROCEDURE

1. To Start Kettle Heating:

- a. EVERY DAY make sure that the jacket water level in the middle of the sight glass. If the level is too low, see "Jacket Filling and Water Treatment" in this manual.
- b. Check the pressure/vacuum gauge. If the gauge does not show 20 to 30 inches of mercury (Hg) vacuum (that is a reading of 20 to 30 below 0

atmospheric pressure), see “Jacket Vacuum” in this manual.

- c. Do not attempt to light any burner with a flame.
 - d. Turn the manual gas valve ON (align handle with gas line).
 - e. Turn rocker (on-off) switch ON. The electronic ignition will attempt to light the pilot for 90 seconds, or until it is lit. Once lit proceed to step two.
 - f. Turn controller to desired setting. The main gas burner will ignite, and will cycle to maintain the set temperature. The heat indicator light will come on.
 - g. If the unit does not light, turn it off and wait five minutes. Then follow the instructions again.
2. To Empty Kettle Or To Transfer Product:
 - a. To tilt the body of the kettle forward, turn the hand crank on the front of the cabinet counter-clockwise. The body will stay in the position it holds when you stop cranking. To return the kettle body to its upright position, turn the crank clockwise.
 - b. Product may also be transferred by means of the optional draw-off valve, if the kettle is so equipped.
 3. To Stop Kettle Heating:
 - a. Turn controller dial to OFF/ZERO.
 - b. Turn power switch to OFF.
 - c. For a prolonged shut-down:
 1. Follow the procedure above.
 2. Turn the manual gas valve off (handle at right angles to gas line).
 3. Disconnect electric power from the unit.
 4. To Relight Kettle
 - (a) Close main gas supply valve.
 - (b) Set on-off switch to OFF.
 - (c) Set controller dial to OFF.
 - (d) Wait five minutes, then proceed as directed under To Start Kettle Heating.
 5. If Power Fails:
 - (a) Do not attempt to operate the unit until electric power is restored.
 - (b) When power comes back on, follow directions “To Start Kettle,” above.

USE OF COMMON ACCESSORIES

1. Lift-Off or Counterbalanced Cover:

As with stock pot cooking, an optional cover can speed up the heating of water and food products. It helps retain heat and reduces the heat and humidity in the kitchen. A cover can reduce some product cook times and help maintain the temperature, color and texture of products held or simmered for longer periods.

Be sure the handle is secure on the lift-off cover before using. ALWAYS use the handle to place or remove cover from the kettle. Wear protective oven mitts and apron.

When putting a lift-off cover on the kettle, position it on top of kettle rim, with its flat edge facing the pouring lip.

When removing a lift-off cover:

- a. Firmly grasp the handle, and lift the rear edge (farthest from operator) 1-2” (3-5 cm) to allow steam and water vapor to escape. Wait 2-3 seconds.
- b. Tilt cover to 45-60° angle to allow any hot condensate or product to roll off cover back into kettle.
- c. Remove cover, ensuring that remaining hot condensate or product does not drip on operator, floor or work surfaces.
- d. Place cover on safe, flat, sanitary, out-of-the-way surface, or return to kettle.

2. Basket Insert:

An optional kettle basket insert set (Tri-BC) will assist in cooking water-boiled products including eggs, potatoes, vegetables, shell fish, pasta and rice. The nylon mesh liner must be used for products smaller than the basket mesh size, (approx. ¼” (6 mm). This includes rice and small pasta shapes.

- a. Allow for displacement of the three baskets and product. This may mean only half filling the kettle. Test baskets and product displacement with the kettle OFF, and with cold water in the kettle.
- b. Load baskets on a level, stable work surface.
- c. Lift loaded baskets with both hands. Get help from another person if the basket is too heavy for safe handling.
- d. Slowly lower product into kettle and securely hook basket to the “Y” frame.
- e. When removing baskets with cooked product, lift straight up, ensuring basket bottoms clear the kettle rim and pouring lip. Wear protective oven mitts and protective apron.
- f. Allow hot water to fully drain from product, before moving basket away from the kettle. Do not rest baskets on kettle rim or pouring lip. If baskets are too heavy for individual to lift and safely move, get help. Remove product immediately from basket into another container, being sure to avoid contact with hot product and hot basket or...
- g. Place baskets with food on a stable, flat surface, inside a solid steamer or bake pan, to catch any remaining hot water draining from product.

CLEANING

WARNING: KEEP WATER AND SOLUTIONS AWAY FROM CONTROLS AND ELECTRICAL EQUIPMENT. NEVER SPRAY THE SUPPORT HOUSING OR ELECTRICAL CONNECTIONS.

CAUTION: MOST CLEANERS ARE HARMFUL TO THE SKIN, EYES, MUCOUS MEMBRANES, AND CLOTHING. PRECAUTIONS SHOULD BE TAKEN. WEAR RUBBER GLOVES, GOGGLES OR FACE SHIELD, AND PROTECTIVE CLOTHING. READ THE WARNINGS AND FOLLOW THE DIRECTIONS ON THE LABEL OF THE CLEANER CAREFULLY.

CAUTION: NEVER LEAVE A SANITIZER IN CONTACT WITH STAINLESS STEEL SURFACES LONGER THAN 30 MINUTES. LONGER CONTACT CAN CAUSE CORROSION.

CAUTION: DO NOT MIX PARTS OF DIFFERENT DRAW OFF VALVE ASSEMBLIES. THE PARTS ARE NOT INTERCHANGEABLE.

NOTICE: NEVER LEAVE A CHLORINE SANITIZER IN CONTACT WITH STAINLESS STEEL SURFACES LONGER THAN 30 MINUTES. LONGER CONTACT CAN CAUSE STAINING AND CORROSION.



SUGGESTED CLEANING SUPPLIES

1. Cleaner, such as Klenzade HC-10 or HC-32 from ECOLAB, Inc. or equivalent.
2. Kettle brushes in good condition
3. Sanitizer such as Klenzade XY-12.
4. Film remover such as Klenzade LC-30.

PRECAUTIONS

Before cleaning, shut off the kettle by turning the controller dial and power switch to “OFF,” and shut off all electric power to the unit at a remote switch, such as the circuit breaker.

PROCEDURE

1. Clean food-contact surfaces as soon as possible after use. If the unit is in continuous use, thoroughly clean and sanitize the interior and exterior at least once every 12 hours.

2. Scrape and flush out food residues. Be careful not to scratch the kettle with metal implements. (For DHT models only: After flushing the kettle, close the draw-off valve.)
3. Prepare a hot solution of the detergent/ cleaning compound as instructed by the supplier. Clean the unit thoroughly. A cloth moistened with cleaning solution can be used to clean controls, housings, and electrical conduits.
4. Model DHT only: Disassemble the tangent draw-off valve. Clean the draw-off port and each valve part with a brush.
5. Rinse the kettle and draw-off valve parts thoroughly with hot water, then drain completely.
6. When you reassemble the draw-off valve, hand-tighten the nut which holds it in place.
7. As part of the daily cleaning program, clean soiled external and internal surfaces. Remember to check the sides of the unit and control housing, underside of cover, etc.
8. To remove burnt on foods, use a brush, sponge, cloth, plastic or rubber scraper, or plastic wool with the cleaning solution. To reduce effort required in washing, let the detergent solution sit in the kettle and soak into the residue. Do NOT use abrasive materials or metal tools that might scratch the surface. Scratches make the surface harder to clean and provide places for bacteria to grow. Do NOT use steel wool, which may leave particles in the surface and cause eventual corrosion and pitting.
9. The outside of the unit may be polished with a stainless steel cleaner such as "Zepper" from Zep Manufacturing Co.
10. When equipment needs to be sanitized, use a solution equivalent to one that supplies 200 parts per million available chlorine. Obtain advice on sanitizing agents from your supplier of sanitizing products.
11. Following the supplier's instructions, apply the agent after the unit has been cleaned and drained. Rinse off the sanitizer thoroughly.
12. It is recommended that each piece of equipment be sanitized just before use.
13. If there is difficulty removing mineral deposits or a film left by hard water or food residues, clean the kettle thoroughly and then use a deliming agent, like Groen Delimer/Descaler (Part Number 114800), in accordance with the manufacturer's directions. Rinse and drain the unit before further use.
14. If cleaning problems persist, contact your cleaning product representative for assistance. The supplier has a trained technical staff with laboratory facilities to serve you.

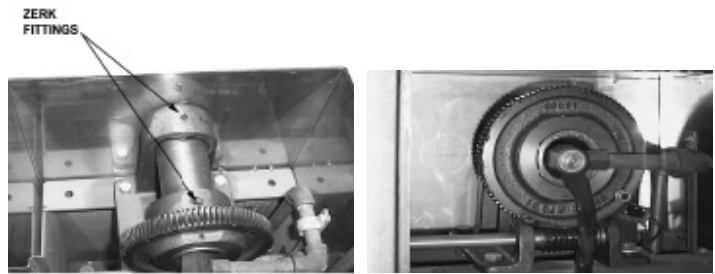

Add grease through Zerk Fittings

Liberal grease the wheel where it contacts the worm gear

PERIODIC MAINTENANCE

NOTICE: Contact an authorized representative when repairs are required.

A service Log is provided at the back of this manual with the warranty information. Each time maintenance is performed on your Groen kettle, enter the date on which the work was done, what was done, and who did it. Keep this manual on file and available for operators to use. Periodic inspection will minimize equipment down time and increase the efficiency of operation. The following points should be checked:

1. Check the pressure/vacuum gauge every day. The gauge should show a vacuum of 20 to 30 inches mercury (Hg), when the kettle is cold. If it does not, see "Jacket Vacuum" in this manual.
2. Also check the jacket water level every day. It should be in the middle of the sight glass. If the level is low, see "Jacket Filling and Water Treatment" in this manual.
3. Carefully test the pressure relief valve at least twice each month. With the kettle operating at five psi (105 kPa), pull the test lever and let it snap back to its closed position. If there is little discharge (mostly air), and the pressure gauge drops back to zero PSI, allow the pressure to build back to five PSI and repeat the procedure. (Tip: Using a screwdriver or other implement to pull the ring will help you avoid contact with the steam.)
4. If the valve does not activate, or there is no evidence of discharge, or the valve leaks, stop using the kettle and contact a qualified Groen service representative.
5. Keep the primary burner gas jet air inlets free of dust and lint.
6. The pilot flame should be blue. It should envelop about ½ inch (12 mm) of the flame sensor tip.
7. The gear housing has fittings for lubrication of moving parts. The gears do not run in oil, so periodic lubrication with grease is necessary.
8. Frequency of lubrication depends on operating conditions, but it should be done at least once every six months.
9. Use a #2 grade LGI lithium grease to add grease through Zerk fittings on gear housing until it flows out of the bearings around the trunnion shaft.
10. Place liberal amounts of grease on the gear to cover the arc that is in contact with the worm gear.
11. Keep electrical wiring and connections in good condition.
12. Keep the inside of the control console clean and dry.
13. Keep burner slots clean.

MAINTENANCE

WARNING: WHEN TESTING, AVOID ANY EXPOSURE TO THE STEAM BLOWING OUT OF THE SAFETY VALVE. DIRECT CONTACT COULD RESULT IN SEVERE BURNS.

WARNING: TO AVOID INJURY, READ AND FOLLOW ALL PRECAUTIONS ON THE LABEL OF THE WATER TREATMENT COMPOUND.

WARNING: BEFORE REPLACING ANY PARTS, DISCONNECT THE UNIT FROM THE ELECTRIC POWER SUPPLY AND CLOSE THE MAIN GAS VALVE. ALLOW FIVE MINUTES FOR UNBURNED GAS TO VENT.

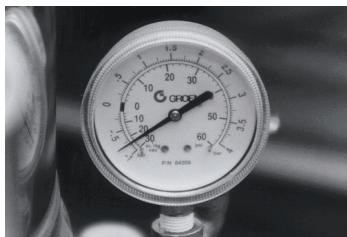

The pressure gauge should show a vacuum of 20 to 30 inches when the kettle is cold



Safety Valve

Pressure Gauge

JACKET VACUUM/REMOVING AIR FROM JACKET

When the kettle is cold, a positive pressure reading on the pressure/vacuum gauge or a reading near zero indicates that there is air in the jacket. Air in the jacket acts as an insulator, and slows kettle heating.

To remove air:

1. Start the unit. (Be sure there is water or product in the kettle when heating).
2. When the pressure/vacuum gauge reaches a positive pressure reading of five PSI, release the trapped air and steam by pulling up the safety valve ring for about five seconds. Repeat this step three or four times. Then let the pull ring snap back into the closed position.
3. If there is little discharge (mostly air), and the pressure gauge drops back to zero PSI, allow the pressure to build back to five PSI and repeat the procedure.
4. Once steam has been vented from the jacket as described in b, above, remove the hot water from the kettle and replace it with cold. This will condense steam in the kettle jacket, and the pressure gauge should show a reading of 20 to 30 inches mercury (Hg) below zero. If it does not, or if the vacuum is leaking down, contact a Groen authorized service agency to correct the problem.

JACKET FILLING AND WATER TREATMENT

The jacket was charged at the factory with the proper amount of treated water. You may need to restore this water, either because it was lost as venting steam or by draining. If you are replacing water lost as steam, use distilled water. If you are replacing treated water that ran out of the jacket, prepare more treated water as directed in "Water Treatment Procedure," below.

1. Allow the kettle to cool completely. The procedure will be easier with the kettle under vacuum (pressure gauge reading below zero).
2. Remove pressure gauge with open-ended wrench or crescent wrench.
3. Position a funnel in the opening and fill it with properly treated water.
4. Pull the safety valve to allow water to be sucked into the jacket. Release the valve to prevent air from entering.
5. Check water level in the jacket to ensure that it is between minimum and maximum marks on glass or at the top of the sight glass port for models DH/DHT-80.
6. Apply Teflon tape to pressure gauge threads in a clockwise pattern, then reinstall.
7. Reestablish the jacket vacuum as described above, if the pressure gauge does not show a negative reading of 20 to 30 inches mercury (Hg).

WATER TREATMENT PROCEDURE

1. Obtain water treatment compound and a pH test kit from your Groen Service Agent.
2. Fill a mixing container with the measured amount of water required. Distilled water is recommended.

Kettle Model	Recommended Jacket Fill
DH-20, DHT-20	1-3/4 Gallons
DH/1-40, DHT/1-40	1-1/2 Gallons
DH-60, DHT-60	3 Gallons
DH-80, DHT-80	3 Gallons

3. Hang a strip of pH test paper on the rim of the container, with about 1 inch of the strip below the surface of the water.
4. Measure the water treatment compound. One way to do this is to add the compound from a measuring cup.
5. Stir the water continuously, while you slowly add treatment compound, until the water has a pH between 10.5 and 11.5. Judge the pH by frequently comparing the test strip color with the color chart provided in the test kit. Caution: Do not add excess amount of treatment compound. Excess amount could cause extensive corrosion.

6. As you add water to the jacket, check water level to ensure that it is between minimum and maximum marks on glass or at the top of the sight glass port for models DH/DHT-80. Stop adding water when it reaches the maximum marker on the gauge.
7. Record the exact amounts of water and treatment compound needed. These amounts may be used again, if the same water sources and compound are used. However, it is best to check the pH each time treated water is prepared.

COMPONENT REPLACEMENT

When component replacement involves breaking a gas pipe connection, check the new connection with soap solution or an appropriate leak detector. DO NOT USE A FLAME TO TEST FOR LEAKS.

Internal wiring is marked as shown on the circuit schematic drawings (inside control housing and in this manual). Be sure that new components are wired in the same manner as old components. An examination of the circuit schematic shows that the safety components are wired in series. In most cases, a faulty component may be isolated with a jumper wire to verify that the component is faulty. If this determination is made, contact a certified Groen Service Agency for assistance.

SEQUENCE OF OPERATION

The following "action-reaction" outline is provided to help understand how the kettle works.

1. When the power switch is turned on, it starts the spark igniter and opens the automatic valve for the pilot burner. The spark ignites a pilot flame, which heats the sensor. The sensor then sends a signal to turn off the spark. The flame thereafter acts as a standing pilot until the power is turned off.
2. If the pilot flame is not sensed within 90 seconds after spark begins, a timer shuts down the entire operation. To attempt a second trial for ignition, turn off the power switch. Check the gas supply valves and wait five minutes before trying again by switching power on. If you cannot establish a pilot flame in four tries, close all valves, turn off the power, and contact an authorized Groen Service Agency.
3. When the operator sets a temperature on the controller, it causes the automatic valve to admit gas to the main burner, where it is ignited by the pilot flame. When the kettle reaches the set temperature, the controller switch opens. This stops the signal to the gas control valve and shuts off gas to the main burner. The pilot flame remains lit. When the kettle cools below the set temperature, the controller switch closes and starts another cycle. On and off cycling continues and maintains the kettle at the desired temperature. This action is indicated by the Heat indicator light.

The kettle has the following safety features in addition to the 90-second ignition timer:

1. Low water cutoff relay that will shut off gas supplies to all burners until the jacket water level is corrected.
2. High limit pressure switch, set to open at about 46 PSI and to shut down the burners until jacket pressure is decreased.
3. Pressure relief valve, which will release steam if jacket pressure exceeds 50 PSI.
4. Tilt switch, which shuts off all burners when the kettle is tilted.
5. Gas pressure regulator built into the gas control valve.

SERVICING & CONVERSION

IMPORTANT: BEFORE ATTEMPTING ANY SERVICING, ENSURE THAT THE ISOLATING COCK IS TURNED OFF AND CANNOT BE INADVERTENTLY TURNED ON. ENSURE ALSO THAT THE ELECTRICITY SUPPLY IS DISCONNECTED. AFTER ANY MAINTENANCE TASK, CHECK THE APPLIANCE TO ENSURE THAT IT PERFORMS CORRECTLY AND CARRY OUT ANY NECESSARY ADJUSTMENTS AS DETAILED IN THIS MANUAL. ALWAYS CHECK FOR GAS SOUNDNESS AFTER CARRYING OUT ANY SERVICING OR EXCHANGE OF GAS CARRYING COMPONENTS.

NOTE: 1. WHEN REPLACING WIRING CONNECTIONS REFER TO THE WIRING DIAGRAM CONTAINED ON THE UNIT AND WITHIN THIS MANUAL.

2. WHEN ANY THREADED GAS CONNECTION IS DISTURBED FOR ANY REASON, THE THREADS MUST BE RESEALED WITH APPROPRIATE GAS LEAK PREVENTION SEALANT THAT IS SUITABLE FOR THE TYPE OF GAS. GROEN/GROEN RECOMMENDS GAS SEALANT COMPOUND SUCH AS LOCKTITE® 243 OR GROEN PART NUMBER 122002.

WARNING: AVOID ANY EXPOSURE TO THE STEAM BLOWING OUT OF THE SAFETY VALVE.

CAUTION: BEFORE TESTING, MAKE CERTAIN DISCHARGE PIPE IS PROPERLY CONNECTED TO VALVE OUTLET AND ARRANGED TO CONTAIN AND SAFELY DISPOSE OF BOILER DISCHARGE (SEE "INSTALLATION INSTRUCTIONS").

AFTER SERVICING

1. Test for gas soundness as specified in IGE/UP1 as appropriate after any gas connection has been disturbed.
2. If leaks are found, disconnect the mating parts, clean the threads and apply recommended sealant as specified in Note 2 above. **WARNING** Do not leave any wood splinter or bristles from brush in the burner or injector. Fire could result.
3. Check for correct operation, as appropriate (see commissioning of appliance).

REGULAR SERVICING PROCEDURES

The following must be serviced at regular intervals.

BURNERS

The burner should be cleaned periodically to maintain maximum performance. Burners are best cleaned with a wire brush and any blocked parts are best cleaned with a metal broach, taking care not to damage the burner head. The injector orifice should be cleaned with a wooden splinter. Metal reamers may distort or increase the orifice size and should be avoided. **WARNING** - Do not leave any wood splinter or bristles from brush in the burner or injector. Fire could result.

GEARS

The gear housing has fitting for proper lubrication of moving parts. The gears do not run in oil, periodic lubrication with grease is necessary. Frequency of lubrication will depend on operating conditions, but it should be performed at least once every 6 months. It is recommended that a #2 grade LGI lithium grease be used. Add grease through the Zerk fittings on the gear housing until grease flows out of bearings around the trunnion shaft. Place a liberal amount of grease on the gear to cover the arc that is in contact with the worm gear.

SAFETY VALVE (STEAM)

At least twice a month the safety valve requires checking to make sure it works correctly. When the gauge pressure is about five PSI, lift the valve lever enough to vent steam, then quickly let it snap back into place. This procedure should be explained to the user, since it is to be carried out at least twice a month. Safety procedures and requirements should also be explained to the user when carrying out the procedure.

SAFETY VALVE OPERATING INSTRUCTIONS

If adding water to the boiling pan jacket, DO NOT ALLOW water to flow through safety valve as sediment or debris may be deposited on seating surface. To achieve topmost performance and maximum service life, it is necessary to maintain a proper pressure margin between set pressure of the safety valve and equipment operating pressure.

The minimum required pressure margin for this type of valve is 10% of the safety relief valve set pressure, but not less than five PSI. UNDER NO CIRCUMSTANCES SHOULD THIS MARGIN BE LESS THAN 5 PSI. Failure to maintain this operating margin may result in water leakage past the seat and accumulation of deposits on the seating surface. Excessive deposits may prevent the valve from operating properly, and a dangerous pressure build-up and equipment rupture may result.

MAINTENANCE AND TESTING



Test the operation of the safety valve on a regular basis.

Under normal operating conditions a "try lever test" must be performed every two months. Under severe service conditions, or if corrosion and/or deposits are noticed within the valve body, testing must be performed more often. A "try lever test" must also be performed at the end of any non-service period.

Test at or near maximum operating pressure by holding the test lever fully open for at least 5 seconds to flush the valve seat free of sediment and debris. Then release lever and permit the valve to snap shut.

If lift lever does not activate, or there is no evidence of discharge, discontinue use of equipment immediately and contact a licensed contractor or qualified service personnel.

Neither Conbraco Industries, Inc. nor its agents assume any liability for valves improperly installed or maintained.

This quality Conbraco safety relief valve, along with proper installation, use, and maintenance, will provide many years of reliable service and protection against excessive pressure build-up of water/steam. Use of this valve for any other purpose or media places all responsibility upon the user. Before installing valve or operating equipment to which it is installed, read instructions carefully. Always wear proper safety equipment.

INSTALLATION OF SAFETY VALVE (STEAM)

1. Installation must be performed by qualified service personnel only.
2. The BTU/hr or lb/hr rating of this valve must equal or exceed that of the equipment to which it is attached.
3. **DO NOT** use this valve on a coal or wood boiler having an uncontrolled heat input.
4. Ensure that all connections, including the valve inlet, are clean and free from any foreign material.
5. Use pipe compound sparingly, or tape, on external threads only.
6. **DO NOT USE A PIPE WRENCH!** Use proper type and size wrench on wrench pads only.
7. This valve must be mounted in a vertical, upright position directly to a clean, tapped opening in the top of the boiler or equipment. Under no circumstances should there be a low restriction or valve of any type between the safety relief valve and the pressure vessel
8. **WARNING!** During operation, this valve may discharge large amounts of steam and/or hot water. To reduce the potential for bodily injury and property damage, a discharge line **MUST** be installed that:

- is connected from the valve outlet with no intervening valve and directed downward to a safe point of discharge.
- allows complete drainage of both the valve and the discharge line
- is independently supported and securely anchored so as to avoid applied stress on the valve.
- is as short and straight as possible.
- terminates freely to atmosphere where any discharge will be clearly visible and is at no risk of freezing.
- terminates with a plain end that is not threaded.
- is constructed of a material suitable for exposure to temperatures of 375°F or greater.
- is, over its entire length, of a size equal to or greater than the valve outlet.

Use only schedule 40 pipe for discharge. (Do not use schedule 80, extra strong pipe or connections). DO NOT CAP, PLUG, OR OTHERWISE OBSTRUCT DISCHARGE PIPE OUTLET!

- See appropriate ASME Boiler and Pressure Vessel Code for additional installation instructions.

CONVERSION

ALL CONVERSIONS MUST BE FOR APPROVED GAS IN THE COUNTRIES LISTED IN THIS MANUAL.
IMPORTANT: THIS APPLIANCE WAS FITTED AT THE FACTORY WITH GAS INJECTORS FOR TYPE OF GAS SPECIFIED ON DATA PLATE. PRIOR TO INSTALLING EQUIPMENT, OR WHEN CONVERTING TO ANOTHER GAS, VERIFY THAT THE INJECTOR SIZE MARKING ON THE GAS INJECTOR MATCHES THE INFORMATION ON THE DATA PLATE FOR THE TYPE OF GAS BEING USED.

See previous content for important information for gas conversion. Verify the type of gas to be used. To change the type of gas used (e.g. G20 to G31, natural gas to propane, or inverse) change the following:

- Burner injectors. See instruction in this manual.
- Gas valve spring. Install per instructions supplied with the spring package as shown below.
- Pilot orifice. The pilot orifice for correct gas must be used. See photo below.
 - Remove the gas line and the connector to the pilot.
 - Remove natural gas/G20 orifice from the pilot. It is marked BCR18.
 - Insert propane/G31 orifice marked BBR14.
 - Reconnect pilot gas line.
- Data plate with correct rate and gas manifold pressure information.

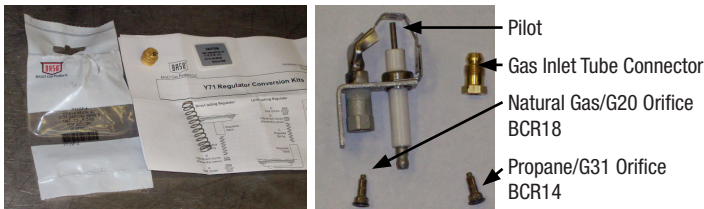

JACKET VACUUM

WARNING: AVOID EXPOSURE TO STEAM BLOWING OUT OF THE SAFETY VALVE.



When the kettle is cold, a positive reading or a reading around zero on the pressure vacuum gauge indicates an excess of air in the jacket. Air in the jacket slows down kettle heating.

To remove air:

- Light the unit.
- When the pressure/vacuum gauge reaches a positive pressure reading of 5 PSI, release air and steam by lifting the lever on the safety valve for about one second. Repeat this a few times. Then let the lever snap back to the closed position.

See detailed Instructions in this section pertaining to Safety Valve installation and operation.

JACKET FILLING

WARNING: TURN OFF GAS AND ELECTRICITY MAINS



The jacket has been charged at the factory with the proper amount of treated, distilled water. You may need to restore jacket water to its proper level, either because it was lost as steam during venting or by draining.

The procedure for adding water follows:

- If you are replacing water lost as steam, use distilled water. If you are replacing treated water that ran out of the jacket, prepare more treated water as directed below.
- Allow the kettle to cool completely. Remove pressure gauge with open-ended wrench or crescent wrench.
- Position a funnel in the opening and fill it with properly treated water. Hold the safety valve open while you pour to let air escape from the jacket.
- Apply teflon tape to pressure gauge threads in a clockwise pattern, then reinstall.
- Air introduced to the jacket during the filling operation must be removed to obtain efficient heating. See Jacket Vacuum.

See detailed Instructions in this section pertaining to Safety Valve installation and operation.

WATER TREATMENT PROCEDURE

WARNING: READ AND FOLLOW WATER TREATMENT COMPOUND LABEL PRECAUTIONS TO AVOID INJURY.

- Fill the mixing container with the measured amount of water required. (See Table). Use distilled water only.

Model	Kettle Capacity	Jacket Capacity
DH-20	20 Gal (75.7 L)	1.75 Gal (6.6 L)
DH-40	40 Gal (151.4 L)	1.88 Gal (7.1 L)
DH-60	60 Gal (227.1 L)	3.0 Gal (11.3 L)
DH-80	80 Gal (302.8 L)	3.0 Gal (11.3 L)

- Hang a strip of pH test paper on the rim of the container, with about 1" of the strip below the surface of the water.

3. Measure the water treatment compound you will be using. (One way to do this is to add the compound to the water from a small measuring cup).
4. Stir the water continuously, while you slowly add water treatment compound, until the water reaches a pH between 10.5 and 11.5. Judge the pH by frequently comparing the color of the test strip with the color chart provided in the pH test kit.
5. Record the exact amounts of water and treatment compound used. These amounts may be used again, if the same sources of water and compound are employed. However, it is advisable to check the pH every time water is prepared. For optimum performance, use correctly treated, distilled water.

CONTROL PANELS

Control Cabinet Side Panel

1. Remove the 14 screws securing the side panel to the control cabinet.
2. Remove panel.
3. Replace in reverse order.

Supporting Column Access Panels

1. Remove the four screws securing the two panels to the supporting column.
2. Remove both panels.
3. Replace in reverse order.

REMOVAL OF SPARK IGNITION MODULE (TURN THE GAS & ELECTRICITY MAINS OFF)

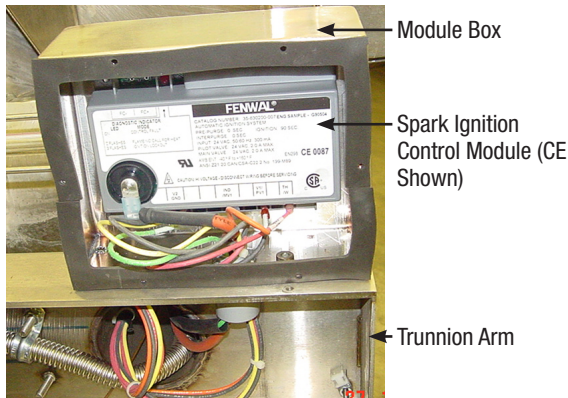

1. Remove supporting column (trunnion arm) access panels.
2. Remove screws on ignition module box and remove cover carefully so as not to damage the water gasket.
3. Disconnect electrical leads from spark ignition module.

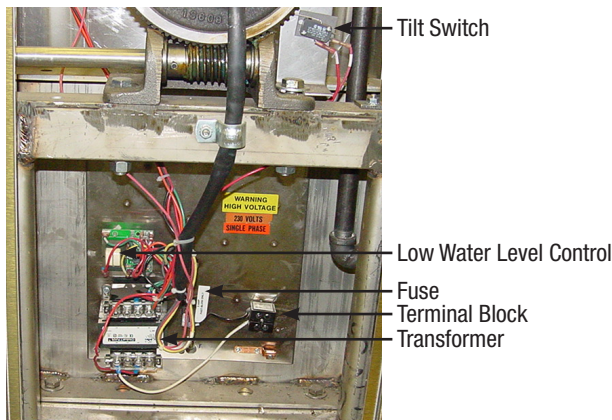

4. Remove retaining screws securing module.
5. Withdraw spark ignition module from control cabinet.
6. Replace in reverse order.
7. NOTE : When replacing spark ignition module, verify that the high voltage

cable to the pilot is not damaged or frayed. If damaged, replace the cable and route it the same as original placement.

REMOVAL OF LOW WATER LEVEL CONTROL, TRANSFORMER OR FUSE REPLACEMENT (TURN THE GAS & ELECTRICITY MAINS OFF)

1. Remove control cabinet side panel.
2. Remove low water level control transformer or the fuse.
3. Replace in reverse order.
4. Ensure the low water level control relay is correctly oriented when re-positioned.

REMOVAL OF TILT SWITCH (TURN THE GAS & ELECTRICITY MAINS OFF)

1. Remove control cabinet lid.
2. Remove control cabinet side panel.
3. Disconnect electrical leads from tilt switch.
4. Remove screws securing the tilt switch.
5. Withdraw tilt switch from control cabinet.
6. Replace in reverse order.
7. Verify that the tilt switch shuts off the burner gas supply when the kettle is tilted. Adjustment range is 5° to 10°.

REMOVAL OF GAS CONTROL VALVE (TURN THE GAS & ELECTRICITY MAINS OFF)

1. Remove panel from kettle base by removing the three (3) retaining screws (see photo below).
2. Undo the gas line fittings on inlet and outlet side of gas valve.
3. Disconnect the electrical leads from the gas valve.
4. Remove the fasteners holding the gas bracket to the kettle body.
5. Carefully tilt the gas valve assembly to access the pilot gas connection.
6. Undo the pilot gas tube connection.
7. Remove the gas valve from kettle.
8. Replace in reverse order.

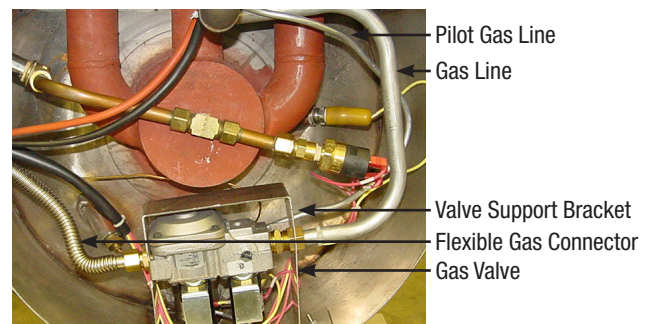
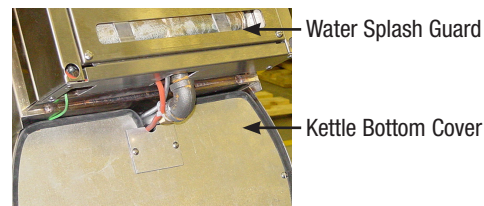

REMOVAL OF ON/OFF SWITCH (TURN THE GAS & ELECTRICITY MAINS OFF)

1. Remove control cabinet side panel.
2. Disconnect electrical leads from the On/Off switch.
3. Withdraw the On/Off switch.
4. Replace in reverse order.

REMOVAL OF ON/OFF SWITCH (TURN THE GAS & ELECTRICITY MAINS OFF)

1. Remove control cabinet side panel.

2. Disconnect electrical leads from the On/Off switch.
3. Withdraw the On/Off switch.
4. Replace in reverse order.

REMOVAL OF LAMPS

Turn gas and electricity mains off

1. Remove cabinet side panel as described in REMOVAL OF CONTROL CABINET PANELS.
2. Disconnect the lamps flying leads.
3. Undo and remove the retaining collar.
4. Remove the 2 nuts retaining the light mount and spacer.
5. Withdraw the lamp from the control compartment.
6. Replace in reverse order.

REMOVAL OF CLASSIC/ADVANCED CONTROLLER

Turn gas and electricity mains off

To Replace:

1. Remove cabinet side panels as described in REMOVAL OF CONTROL CABINET PANELS.
2. Remove 4 nuts retaining controller.
3. Remove electrical leads from controller.
4. Loose control dial set screw and remove dial.
5. Remove controller.
6. Replace in reverse order.

To Calibrate: (classic controls only, if required)

1. Fill the pan with unused oil to the indicated mark. Place a thermocouple 25 mm below the oil surface in the middle of the pan.
2. Light the unit and allow the oil to heat.
3. Temperature should settle at 374°F(±9°F), 190°C (±5°C). If adjustment is required, disconnect main power. Adjustment is located on the back of the control board. Turn adjustment counter-clockwise to increase temperature and clockwise to decrease.

REMOVAL OF PRESSURE SWITCH (TURN THE GAS & ELECTRICITY MAINS OFF)

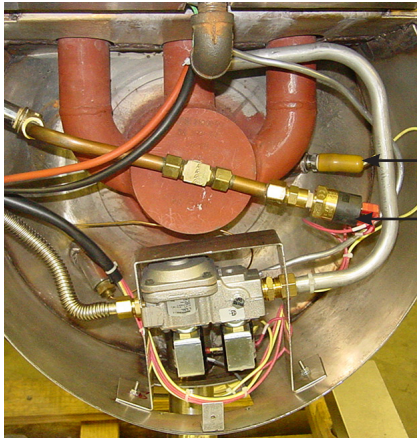

Water Level Sensor
Pressure Switch

1. Remove panel from base of kettle by undoing the retaining screws.
2. Disconnect the electrical leads from the pressure switch.
3. Drain kettle by tilting kettle slightly and undoing the compression fitting at the pressure switch. Allow kettle to drain into a suitably sized container.
4. Remove and withdraw the pressure switch from the kettle base by undoing the compression fitting.
5. Replace in reverse order.
6. Once the pressure switch is in place, the kettle jacket should be refilled. Always refer to wiring diagram when reconnecting electrical leads.

REMOVAL OF LOW WATER LEVEL SENSOR (TURN GAS & ELECTRICITY MAINS OFF)

1. Remove panel from base of kettle by undoing the retaining screws.

2. Disconnect the electrical leads from the water sensor.
3. Drain the kettle by tilting it slightly and undoing the low water level sensor. Allow the kettle to drain into a suitably sized container.
4. Remove the low water level sensor from the kettle base.
5. Replace in reverse order.
6. Ensure a suitable sealant is used to seal the low water level sensor Boss.
7. When the low water level sensor is in place, the jacket should be filled.

REMOVAL OF BURNERS (TURN THE GAS & ELECTRICITY MAINS OFF)

1. Remove water splash guards around the burner.
2. Undo compression fitting at gas pipe to burner manifold and to the pilot.
3. Disconnect electrical leads to the pilot.
4. Remove the four retaining nuts securing the burner and igniter assembly to the combustion chamber. Carefully support the weight of the burner manifold and lower the assembly to a safe position.
5. The burners are now accessible and can be removed as required. Ensure adequate sealant is used to seal the burners.
6. Replace in reverse order. Always check for gas soundness when any part of the gas circuit has been disturbed.

REMOVAL OF PILOT (TURN THE GAS & ELECTRICITY MAINS OFF)

1. Remove water splash guards around the burner.
2. Disconnect the high voltage spark cable from the pilot.
3. Disconnect the ground connection cable from the pilot mounting screw.
4. Remove the second pilot mounting screw.
5. Remove pilot assembly and install new pilot.
6. Replace in reverse order.
7. Ensure that there is an adequate spark at the sparking electrode and that the burners light smoothly and without delay.
8. As the burners ignite, ensure that the sparking sequence stops and that the burners remain lit.

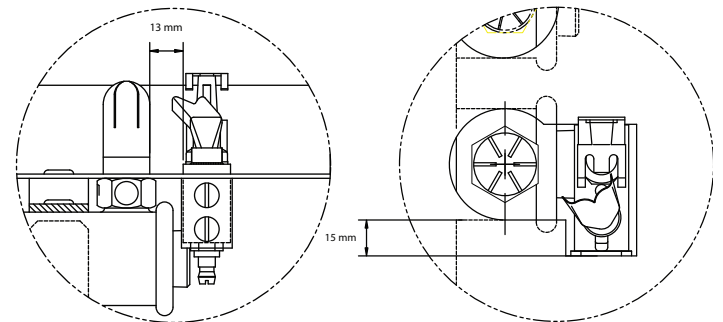
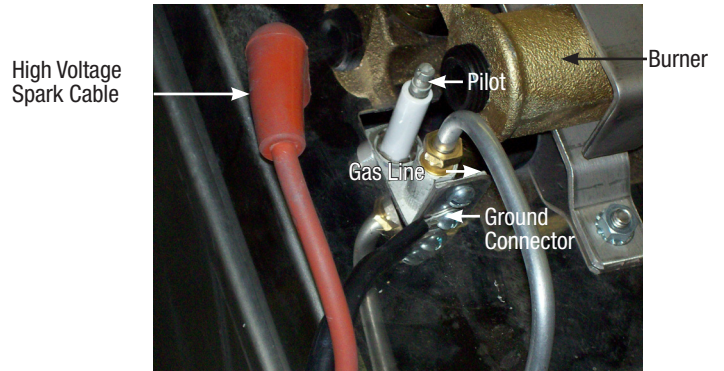

Recommended spacings are shown in the above drawing.

REMOVAL OF PRESSURE GAUGE (TURN THE GAS & ELECTRICITY MAINS OFF)

1. Using the correctly sized spanner remove the pressure gauge from top of the sight glass.
2. Replace with new pressure gauge ensuring that an adequate sealing compound is used.

- Once the pressure gauge has been replaced, the kettle jacket will require venting.

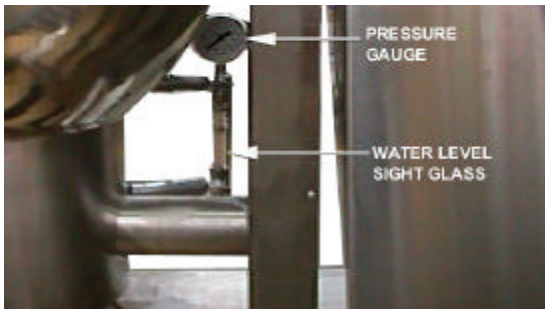

REMOVAL OF SIGHT GLASS (TURN THE GAS & ELECTRICITY MAINS OFF)

- Remove sight glass protection bars.
- Undo top and bottom compression fittings.
- Allow the water in the sight glass to drain.
- Remove the sight glass.
- Replace in reverse order.
- Once the sight glass has been replaced, the lost jacket water requires replacement.

REMOVAL OF STEAM SAFETY VALVE (TURN THE GAS & ELECTRICITY MAINS OFF)

- Remove the elbow from the safety valve.
- Remove the steam safety valve from kettle jacket pipework.
- Replace in reverse order.
- Ensure an adequate sealing compound is used to seal the safety valve.
- Once the steam safety valve has been replaced the jacket will need to be vented. See detailed Instructions pertaining to Steam Safety Valve installation and operation.

REMOVAL OF FILLING VALVE (TURN THE GAS & ELECTRICITY MAINS OFF)

- Remove filling valve from kettle jacket pipework.
- Replace in reverse order.
- Ensure adequate sealing compound is used to seal the valve.
- Once the fill valve has been replaced the jacket will need to be vented.

REPLACEMENT PARTS

To order parts, contact your Authorized Service Agent. Supply the model designation, serial number, part description, part number, quantity, and when applicable, voltage and phase.

CONTACT US

If you have questions pertaining to the content in this manual, contact Groen at 888-994-7636.

TROUBLESHOOTING

This unit is designed to operate smoothly and efficiently if properly maintained. However, the following is a list of checks to make in the event of a problem. Wiring diagrams are found at the end of this manual. When in doubt, turn unit off and call for service at 888-994-7636. If an item on the check list is marked with (X), it means that the work should be done by an Authorized Service Agent.

SYMPTOM	WHO	WHAT TO CHECK
		X indicates items which must be performed by authorized technician.
Display not lit (Advanced only)	User	a. That power supply is on.
	Auth Service Rep Only	b. Fuses, accessible by removing caps on the side of the control box. c. For loose or broken wires. X d. Temperature controller functioning, by listening for a click when the switch opens or closes and verifying LEDs on back of board. X e. Contactor functioning. X
PROB in display (Advanced only)	Auth Service Rep Only	a. For loose or broken wires or damaged/failed RTD probe. X b. PCB board malfunction/failure
HI in display (Advanced only)	Auth Service Rep Only	a. For loose or broken wires or damaged/failed RTD probe. X b. PCB board malfunction/failure
Kettle is hard to tilt	User	a. Gears for foreign materials, and lubrication.
	Auth Service Rep Only	b. Gears for alignment. X c. Worm gears or broken gears. X
Kettle continues heating after it reaches the desired temperature	User	a. Temperature Controller dial setting.
	Auth Service Rep Only	b. Temperature Controller calibration and offset. X c. Temperature Controller operation. The Temperature Controller should click when the dial is rotated to settings above and below the temperature of the kettle. X
Kettle stops heating before it reaches the desired temperature	User	a. Temperature Controller dial setting.
	Auth Service Rep Only	b. Temperature Controller calibration and offset. X c. Temperature Controller operation. The Temperature Controller should click when the dial is rotated to settings above and below the temperature of the kettle. X
Safety Valve pops open	User	a. For air in the jacket. See "Jacket Vacuum" in the Maintenance b. Temperature Controller dial setting.
	Auth Service Rep Only	c. For defective Temperature Controller. The relay should click when the dial is rotated to settings above and below the temperature of the kettle. If defective, replace. X d. For defective safety valve. If the valve pops at pressures below 49 PSI, replace. X
Burners will not light	User	a. That the main gas supply valve is open. (handle is in line with gas pipe). b. Gas supply to the building. c. That the kettle body is not tilted.
	Auth Service Rep Only	d. Temperature Controller operation. The relay should click when the dial is rotated to settings above and below the temperature of the kettle. X e. That tilt limit switch is closed when body is not tilted. X
System does not produce a spark	Auth Service Rep Only	a. AC voltage between terminals on secondary side of transformer. If it is not 24 Volt, replace the transformer. X b. That the high tension cable is firmly attached and in good condition. If cracked or brittle, replace. X c. Pilot electric ceramic for crack or break. X d. Pilot spark gap. Regap. X
Safety valve leaks a small amount of steam when kettle is operating	User	a. For contamination that prevents seating of the valve. With full pressure in the jacket, pull the lever all the way briefly to blow the valve clean, then let the lever snap back to seat the valve
	Auth Service Rep Only	b. Safety valve for defects. Replace any defective valve with an identical valve. X
Spark is present but the pilot will not light	Auth Service Rep Only	a. That the pilot valve is securely connected to terminals. X b. For 24 VAC at terminals PV and PV/MV. If 24V is not present, replace the ignition control module. X c. That gas pressure is at least 3.5" W.C. (8.7818 ub). c. For gas at the pilot. If it is not flowing: (1) Check the pilot gas line for kinks and obstructions. X (2) Clean orifice, if necessary. X (3) Check magnetic operator for pilot valve on gas valve. Repair or replace as necessary. X d. That the pilot spark gap is located in the pilot gas stream. If not, adjust or replace the pilot burner. X e. For drafts. Shield the pilot burner, if necessary. X
Pilot lights, but main burner will not come on and spark does not stay on	Auth Service Rep Only	a. For 24 V between terminals MV and PV/MV while pilot is burning. If 24V is not present, replace the ignition control module. X b. That gas pressure is at least 3.5" W.C. (8.7818 ub). X c. Electrical connections of the main valve to terminals, to assure that they are securely attached. Check magnetic operator for main valve on gas valve. Repair or replace as necessary. X
Pilot lights, but main burner will not come on, the spark stays on	Auth Service Rep Only	a. Check for bad burner ground. If necessary, repair with high temperature wire. X b. Pilot burner ceramic insulator for cracks. X c. That cable is not grounded out. If it is, correct the ground-out condition or replace cable. X d. For proper gas pressure. X e. Clean pilot assembly, or replace if necessary. X f. Tighten all mechanical and electrical connections. X g. If the pilot flame is weak, increase pilot orifice size. X h. Replace ignition control module. X
Main burner comes on but will not stay on	Auth Service Rep Only	a. Check burner ground for bad wire or connection. Replace if necessary with high temperature wire. X b. Check for low gas supply pressure. If necessary, replace ignition control module. X

For Classic & Advanced
Control Models

Parts List

STAND & HOUSING ASSEMBLY

Ref	Description	Part #	QUANTITY		
			20 Gal	40 Gal	60 Gal
1	WELDMENT, FRAME, STAND	174805	1	-	-
1	WELDMENT, FRAME, STAND	174802	-	1	1
2	WELDMENT, CLADDING, STAND	174806	1	-	-
2	WELDMENT, CLADDING, STAND	174812	-	1	1
3	WELDMENT, PEDESTAL	175379	1	-	-
3	WELDMENT, PEDESTAL	175330	-	1	1
4	WELDMENT, CLADDING, PEDESTAL	175378	1	-	-
4	WELDMENT, CLADDING, PEDESTAL	175337	-	1	1
5	PANEL, SIDE, PEDESTAL	175383	1	-	-
5	PANEL, SIDE, PEDESTAL	175336	-	1	1
6	SCREW, MACHINE, HEX HEAD, 1/2-13 X 1-1/2" LONG	008679	4	4	4
7	NUT, HEX, 1/2"-13	005603	4	4	4
8	WASHER, LOCK, 1/2	005657	4	4	4
9	WASHER, PLAIN, 1/2	005049	8	8	8
10	WASHER, LOCK, #8	012971	2	2	2
11	SCREW, MACHINE, TRUSS HEAD 8-32 X 3/8" LONG	137766	14	14	14
-	FOOT, ADJUSTABLE, BULLET-FITS 2" TUBE	013275	4	4	4
-	FOOT, ADJUSTABLE, FLANGED-FITS 2" TUBE	096569	4	4	4
-	EQUIPOTENTIAL ASSEMBLY (CE ONLY)	122021	1	1	1

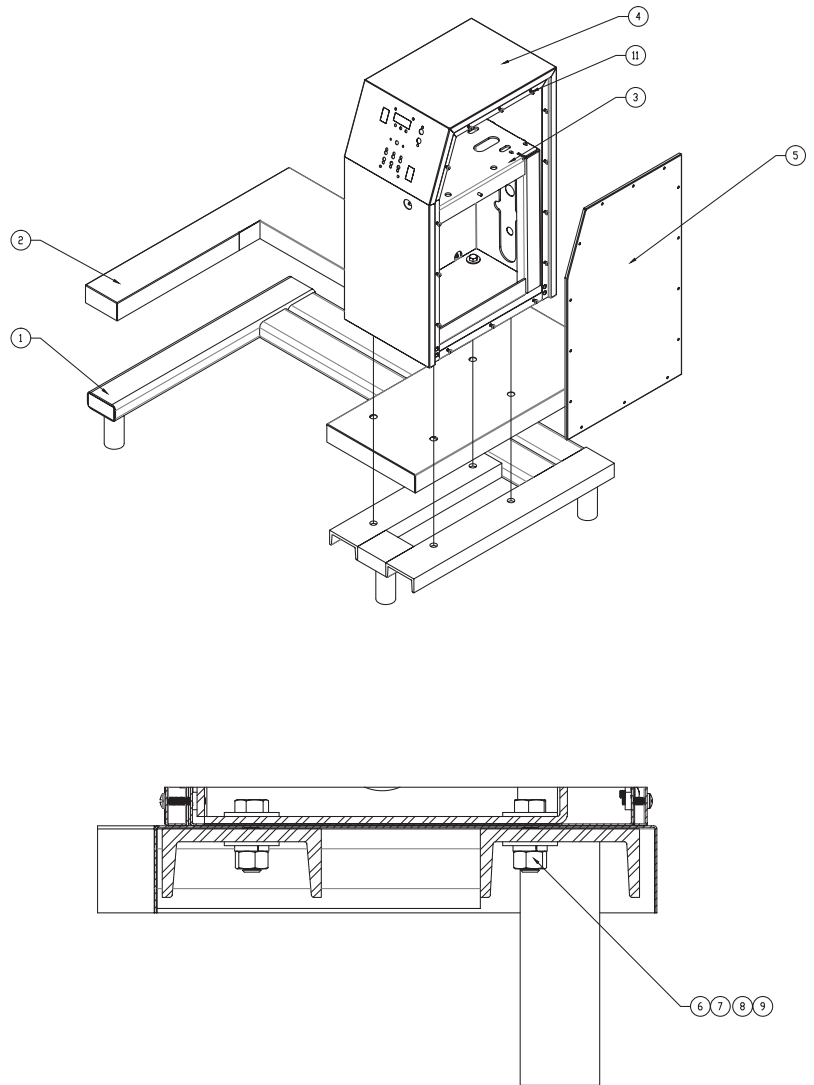

Parts List

GAS VALVE, PIPING & BOTTOM COMPONENTS

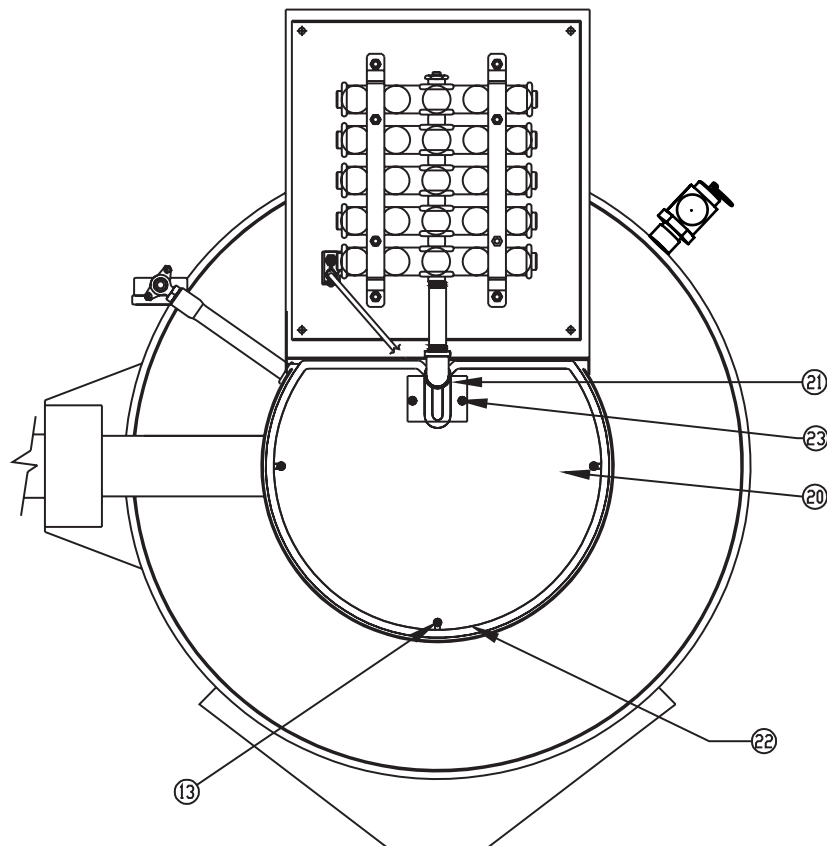
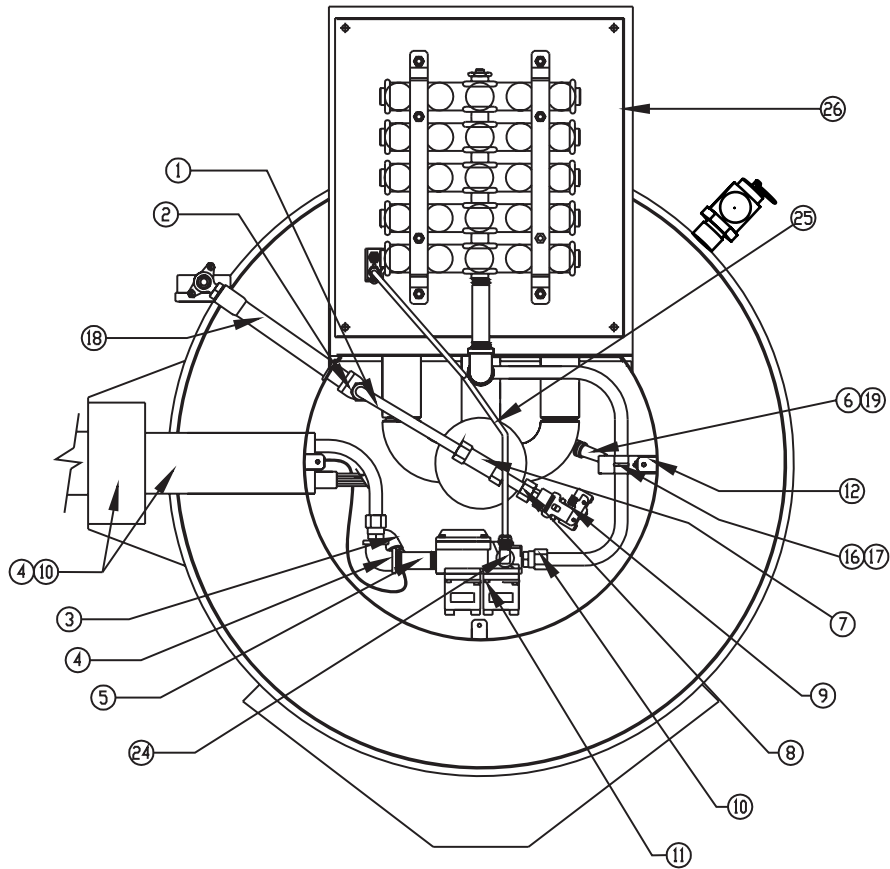

Parts List

GAS VALVE, PIPING & BOTTOM COMPONENTS

Ref	Description	Part #	QUANTITY			
			20 Gal	40 Gal	60 Gal	80 Gal
1	TUBE, COPPER, 1/2" OD, SOFT	007334	18 IN	18 IN	10 IN	10 IN
2	ELBOW, 90 DEG, 1/2 NPT, FEMALE	055634	1	1	1	-
3	THERMOSTAT, ELECTRIC	009730	1	1	1	1
4	ELBOW, 90 DEG, 1/2 NPT	008747	4	4	4	5
5	NIPPLE, 1/2 NPT X 2-1/2" LONG	005552	1	1	1	1
6	PROBE, WATER LEVEL, LOW	079811	1	1	1	1
7	TEE, 1/2 TUBE X 1/2 TUBE X 3/8 NPT MALE	074593	1	1	1	-
8	FITTING, COMPRESSION, STRAIGHT, 1/4 NPT FEMALE	097074	1	1	1	1
9	SWITCH, PRESSURE, 1/4" NPT	096963	1	1	1	1
9	SWITCH, PRESSURE, 1/4" (CE)	177794	1	1	1	1
10	FITTING, COMPRESSION, 5/8 TUBE X 1/2 NPT MALE	049093	3	3	3	3
11	VALVE, GAS, NATURAL	123815	1	1	1	1
11	VALVE, GAS, PROPANE	128412	1	1	1	1
11	VALVE, GAS, CE MARK, G20	160776	1	1	1	1
11	VALVE, GAS, CE MARK, G31	160796	1	1	1	1
12	BRACKET, SUPPORT, BOTTOM	065382	3	3	3	3
13	SCREW, TRUSS HEAD, 8-32 X 3/8" LONG	005764	3	3	3	3
14	NUT, HEX, KEPS, 1/4	NT1101	10	10	10	4
16	BAR, 1/8" X 1 X 4-1/4" LONG	005440	1	1	1	1
17	CLAMP, RIGID CONDUIT	068687	1	1	1	1
18	NIPPLE, 1/2 NPT X 5-1/2" LONG, CHROME PLATED	096933	1	1	-	-
18	NIPPLE, 1/2 NPT X 7" LONG, CHROME PLATED	098519	-	-	1	-
19	BOOT, PROBE	101143	1	1	1	1
20	COVER, BOTTOM	049801	1	-	-	-
20	COVER, BOTTOM	090630	-	1	1	-
20	COVER, BOTTOM	149774	-	-	-	1
21	CAP, BOTTOM, COVER PLATE	049803	1	1	1	1
22	GASKET, BOTTOM PLATE	007937	3 FT	3 FT	3 FT	4 FT
24	FITTING, COMPRESSION, 90 DEG ELBOW, 1/8 NPT MALE X 1/4 TUBE	004584	1	1	1	1
25	TUBE, ALUMINUM, 1/4" OD	006796	20 IN	20 IN	20 IN	20 IN
-	FITTING, COMPRESSION, 5/8 TUBE X 1/2 NPT FEMALE	049094	1	1	1	1
-	SCREW, TRUSS HEAD, 10-32 X 3/8" LONG	004173	2	2	2	2
-	STRAP, EMT CONDUIT, 3/4"	135252	3	3	3	2
-	COUPLING, FULL, 1/2" NPT, 150#	005722	1	1	1	1
-	ELBOW, 90 DEG, 3/8 NPT	055335	-	-	-	1

Ref	Description	Part #	20 Gal	40 Gal	60 Gal	80 Gal
-	ELBOW, 90 DEG, UNION, 1/2 NPT	005495	1	1	1	-
-	NIPPLE, 1/2 NPT X CLOSE	008877	1	-	-	1
-	NIPPLE, 1/2 NPT X 3" LONG	005553	1	1	1	2
-	NIPPLE, 1/2 NPT X 3-1/2" LONG	008227	2	2	2	-
-	NIPPLE, 1/2 NPT X 5" LONG	005555	-	-	-	1
-	NIPPLE, 1/2 NPT X 6" LONG	008638	1	-	-	-
-	NIPPLE, 1/2 NPT X 8" LONG	005557	-	2	1	-
-	NIPPLE, 1/2 NPT X 9.5" LONG, BLACK IRON	144360	1	1	1	
-	NIPPLE, 1/2 NPT X 10" LONG	005558	1	-	-	-
-	NIPPLE, 1/2 NPT X 12" LONG	005600	-	1	1	-
-	NIPPLE, 1/2 NPT X 13" LONG	005674	-	-	-	1
-	NIPPLE, 1/2 NPT X 14" LONG	149772	-	-	-	1
-	NIPPLE, 1/2 NPT X 15" LONG	048570	-	-	-	1
-	JOINT, SWIVEL, 1/2 NPT (GAS)	076680	1	1	1	1
-	VALVE, GAS, SHUT-OFF, 1/2 NPT	098458	1	1	1	1
-	SCREW, MACHINE, PAN HEAD, 10-32 X 1/4" LONG	002962	2	2	2	2
-	SCREW, MACHINE, ROUND HEAD, 6-32 X 1/2" LONG	012603	2	2	2	2
-	TUBE, GAS PIPING, SUPPLY SIDE	145038	1	-	-	-
-	TUBE, GAS PIPING, TAKE UP SIDE	145037	1	-	-	-
-	TUBE, GAS PIPING, SUPPLY SIDE	145040	-	1	-	-
-	TUBE, GAS PIPING, TAKE UP SIDE	145039	-	1	-	-
-	TUBE, GAS PIPING, SUPPLY SIDE	145042	-	-	1	-
-	TUBE, GAS PIPING, TAKE UP SIDE	145041	-	-	1	-
-	TUBE, GAS PIPING, SUPPLY SIDE	149765	-	-	-	1
-	TUBE, GAS PIPING, TAKE UP SIDE	150950	-	-	-	1
-	TUBE, GAS PIPING, TAKE UP SIDE	145041	-	-	1	-
-	TUBE, GAS PIPING, SUPPLY SIDE	149765	-	-	-	1
-	TUBE, GAS PIPING, TAKE UP SIDE	150950	-	-	-	1
-	1/2" NPT TO 1/2" BSPT ADAPTER (CE)	116392	1	1	1	-

QUANTITY

Parts List

MODULE BOX

Ref	Description	Part #	Qty
1	NUT, LOCK, 1/2, CONDUIT	005487	1
2	SCREW, TRUSS HEAD, 8-32 X 3/8" LONG	005764	6
3	MODULE BOX	123775	1
3	MODULE BOX (CE)	154061	1
4	GASKET, MODULE BOX	104941	1
4	GASKET, MODULE BOX (CE)	154070	1
5	MODULE, IGNITION	085153	1
5	MODULE, IGNITION (CE)	154059	1
6	NUT, HEX, KEPS, 6-32	071289	2
7	ADAPTER, CONDUIT, PLASTIC, MALE	123733	1
8	COVER, MODULE BOX	104948	1
8	COVER, MODULE BOX (CE)	154067	1
9	NUT, HEX, KEPS, 8-32	069784	1
10	ANCHOR, CABLE TIE, SCREW-MOUNTED	102231	1
11	STRAP, CABLE TIE	011093	1
12	CABLE, HI VOLTAGE, SPARK IGNITION	096728	1
-	SCREW, HEX BINDER HEAD, 10-32 X 3/8" LONG	084201	2

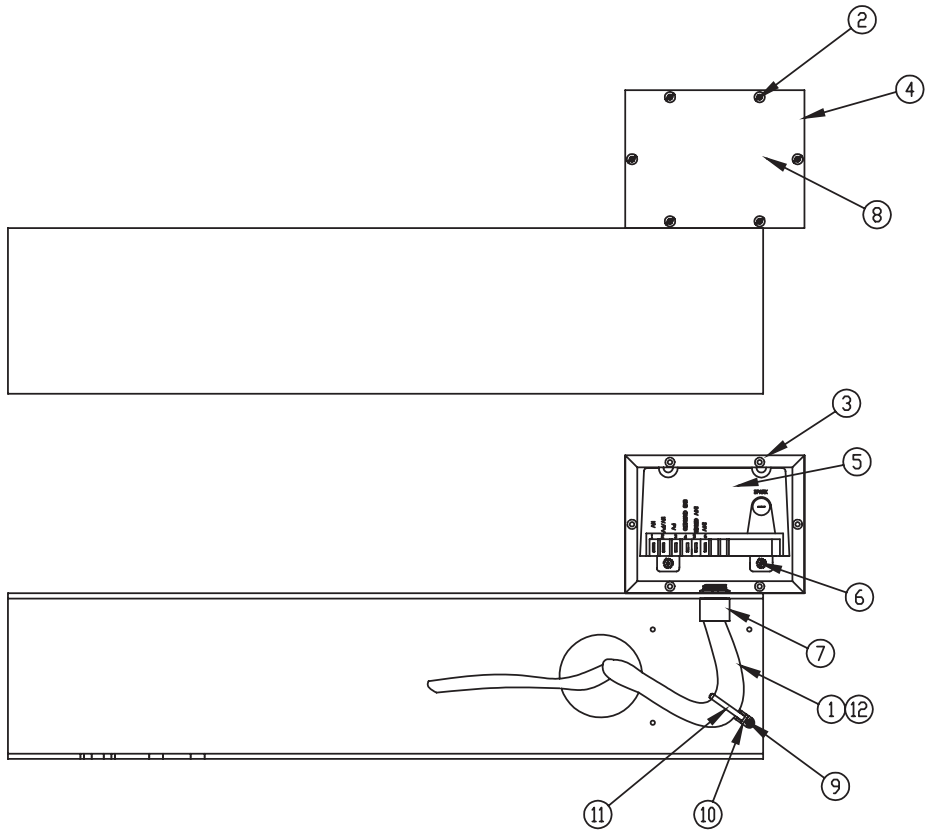

Parts List

BURNER & PILOT/FLAME SENSOR COMPONENTS

Ref	Description	Part #	QUANTITY			
			20 Gal	40 Gal	60 Gal	80 Gal
1	BAFFLE PLATE	123496	1	-	-	-
1	BAFFLE PLATE	123497	-	1	-	-
1	BAFFLE PLATE	123498	-	-	1	1
2	NUT, HEX,SERRATED, 1/4-20	NT1101	8	8	8	8
3	PILOT BURNER, NAT GAS OR G20	123580	1	1	1	1
3	PILOT BURNER, PROPANE OR G31	128415	1	1	1	1
4	BRACKET, BURNER SUPPORT	117008	2	-	-	-
4	BRACKET, BURNER SUPPORT	117009	-	2	-	-
4	BRACKET, BURNER SUPPORT	117010	-	-	2	2
5	BRACKET, BURNER	117011	2	-	-	-
5	BRACKET, BURNER	117012	-	2	-	-
5	BRACKET, BURNER	117013	-	-	2	2
-	WASHER, FENDER, 1/4	132107	-	-	3	3
6	BURNER MANIFOLD AND ORIFICES	NOTE 1	1	1	1	1
NOTE 1	CONTACT FACTORY WITH ELEVATION AND GAS TYPE (NATURAL, PROPANE, G20, G31, OR SPECIAL MIX) TO OBTAIN CORRECTMANIFOLD AND ORIFICES.					

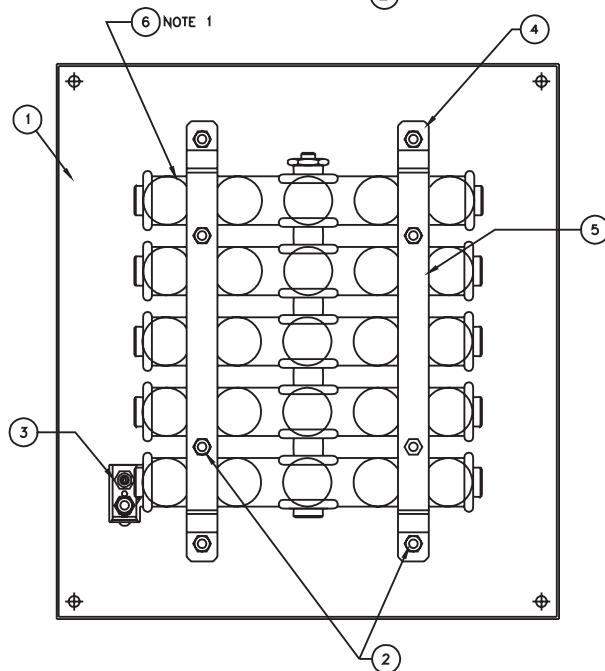
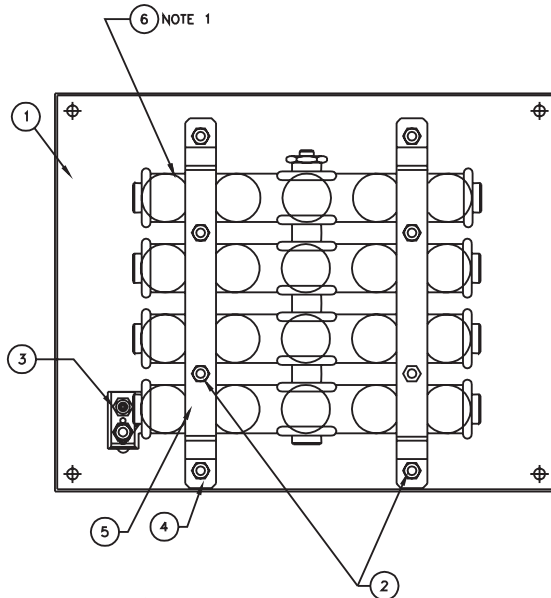
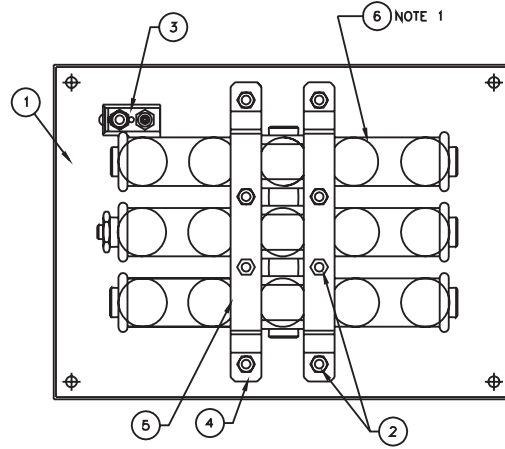

Parts List

FLUE STACK

Ref	Description	Part #	QUANTITY			
			20 Gal	40 Gal	60 Gal	80 Gal
1	FLUE, MAIN BODY & FRONT SECTION	117035 117036	1	-	-	-
1	FLUE, MAIN BODY & FRONT SECTION	117031 117032	-	1	-	-
1	FLUE, MAIN BODY & FRONT SECTION	137874 137872	-	-	1	-
1	FLUE, MAIN BODY & FRONT SECTION	149220 150927	-	-	-	1
2	FLUE, TOP PLATE, TOP SECTION	117038	1	-	-	-
2	FLUE, TOP PLATE, TOP SECTION	117029	-	1	-	-
2	FLUE, TOP PLATE, TOP SECTION	128169	-	-	1	-
2	FLUE, TOP PLATE, TOP SECTION	149222	-	-	-	1
3	FLUE, TOP PLATE, BOTTOM SECTION	117037	1	-	-	-
3	FLUE, TOP PLATE, BOTTOM SECTION	117033	-	1	-	-
3	FLUE, TOP PLATE, BOTTOM SECTION	117028	-	-	1	-
3	FLUE, TOP PLATE, BOTTOM SECTION	149236	-	-	-	1
4	SCREW, TRUSS HEAD, 10-32 X 1/2 LONG	072189	6	6	8	8

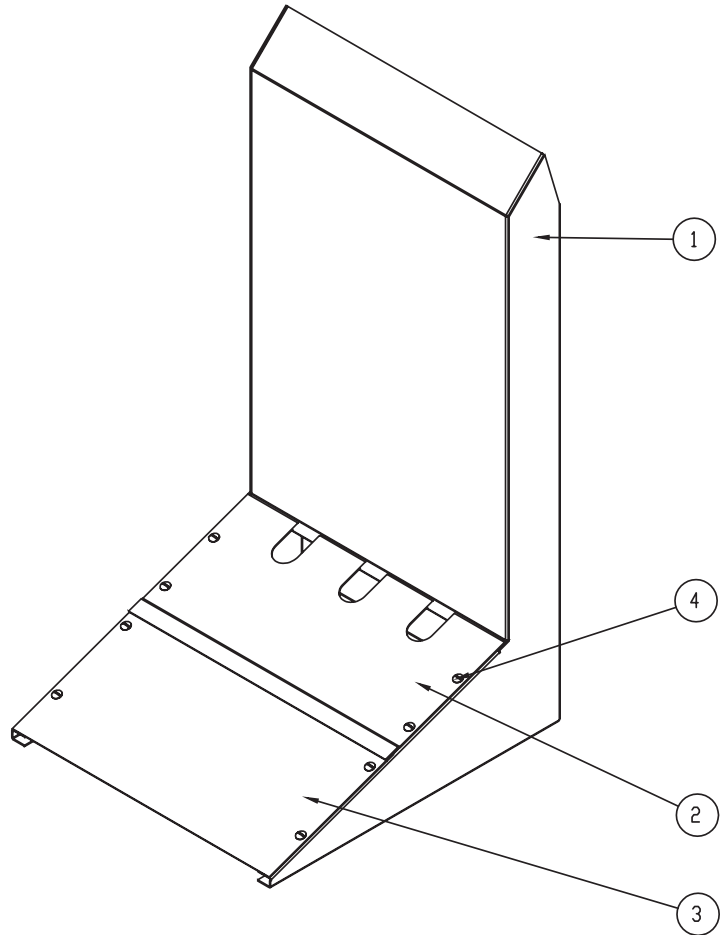

Parts List

ELECTRICAL COMPONENTS

Ref	Description	Part #	Qty
1	ASSEMBLY, BOARD, WATER LEVEL	122192	1
3	LUG, GROUND, #14 - #6 AWG	129714	1
4	SCREW, HEX, SLOTTED HEAD, 8-32 X 3/8" LONG	069789	4
5	WELDMENT, PANEL, ELECTRICAL	138123	1
6	NUT, HEX, KEPS, 10-32	071256	1
7	BLOCK, TERMINAL, 2-POLE	003887	1
8	FUSE, 3.0 AMP, TYPE 3 AG	077853	1
9	HOLDER, FUSE, TYPE 3 AG	077854	1
11	SCREW, ROUND HEAD, MACHINE, 8-32 X 1-1/4" LONG	005056	1
12	SCREW, ROUND HEAD, SELF-TAP, 6-32 X 3/8" LONG	012398	1
12	TRANSFORMER, 20VA, 120V PRIMARY, 24V SECONDARY	137487	1
12	TRANSFORMER, 40VA, 208/240V PRIMARY, 24V SECONDARY	137441	1
-	HARNESS, WIRIN, KETTLE CONTROL	123779	1
-	HARNESS, WIRING, CONTROL PANEL	123582	1
-	LABEL, ELECTRICAL CONNECTION, 115V	102229	1
-	LABEL, ELECTRICAL CONNECTION, 230V	008118F	1
-	STRAP, CABLE TIE	011093	1

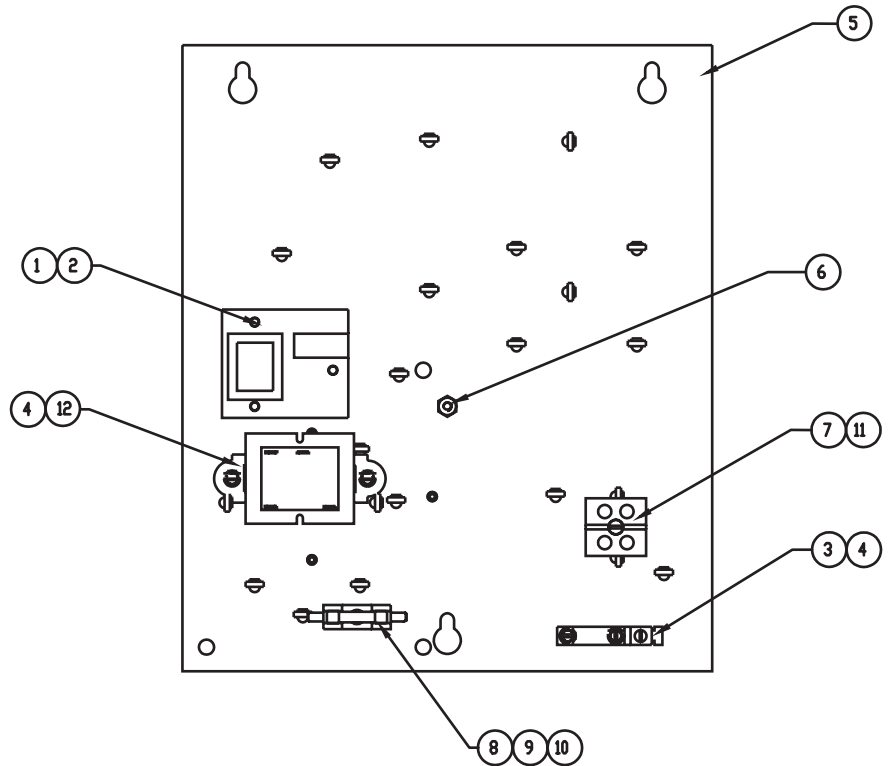

Parts List

ELECTRICAL COMPONENTS

Ref	Description	Part #	Qty
1	ELECTRICAL PANEL WELDMENT	154091	1
2	WATER LEVEL CONTROL BRD ASM	148323	1
3	TERMINAL BLOCK 3-POLE	003888	1
4	FUSE HOLDER TYPE 3 AG	077854	1
5	FUSE 3.0 AMP 250 V	079965	1
6	PC BOARD MOUNTING POST	099901	3
7	SCREW ROUND HEAD 8-32 1-1/4"	005056	2
8	TRANSFORMER, CE, 208/230/460 TO 24V	148899	1
9	LUG GROUND #14-#6 AWG	129714	1
10	SCREW HEX SLOTTED HD WITH WASHER #8-32 X 3/8"	069789	6
11	NUT HEXHEAD KEPS 10-32	071256	1
12	SCREW PAN HEAD #6-32 X 3/8"	009697	1
13	LABEL 3 AMP	102251	1
14	SUPPLY VOLTAGE	114316	1
15	VOLTAGE MARKERS 230	008118F	1
16	VOLTAGE MARKERS SINGLE PHASE	008118K	1
17	LABEL, PROTECTIVE EARTH GND	177427	1
18	EMI FILTER	177768	1

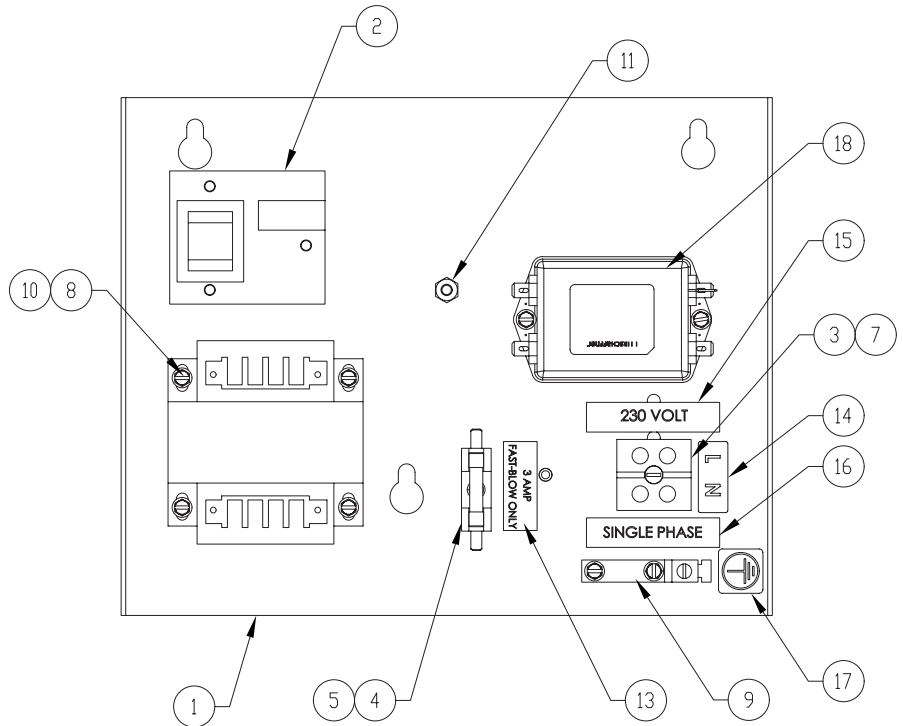

For Classic Control Models

Parts List
FRONT PANEL COMPONENTS

Ref	Description	Part #	QUANTITY		
			20 Gal	40 Gal	60 Gal
1	2" ALUMINUM KNOB	175095	1	1	1
2	POWER SWITCH	174871 177910	1	1	1
3	INDICATOR LIGHT, AMBER	116384	1	1	1
4	INDICATOR LIGHT, RED	116383	1	1	1
5	CLASSIC CONTROLS	174843	1	1	1
-	HEX NUT	101145	1	1	1
-	SPACER, LIGHT MOUNT	175221	1	1	1
-	Bracket, Light Mount	175222	1	1	1
-	Classic Controls Overlay	175303	1	1	1

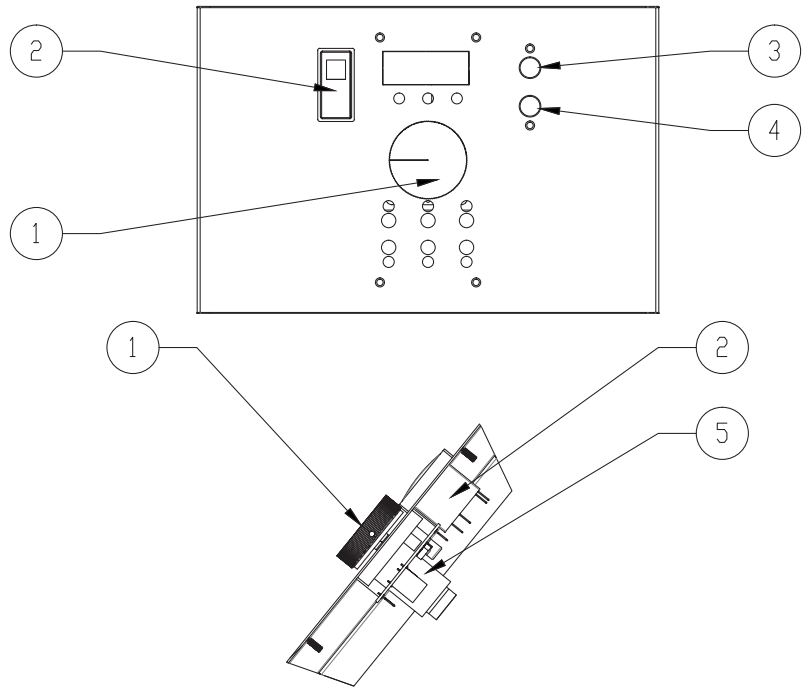

For Advanced Control Models

Parts List
FRONT PANEL COMPONENTS

Ref	Description	Part #	QUANTITY		
			20 Gal	40 Gal	60 Gal
1	2" ALUMINUM KNOB	174829	1	1	1
2	POWER SWITCH	174871 177910	1	1	1
3	INDICATOR LIGHT, RED	116383	1	1	1
4	ADVANCED CONTROLS	174837	1	1	1
5	HEX NUT	101145	1	1	1
6	INDICATOR LIGHT, AMBER	116384	1	1	1
-	SPACER, LIGHT MOUNT	175221	1	1	1
-	BRACKET, LIGHT MOUNT	175222	1	1	1
-	Overlay, Advanced Controls	175304	1	1	1

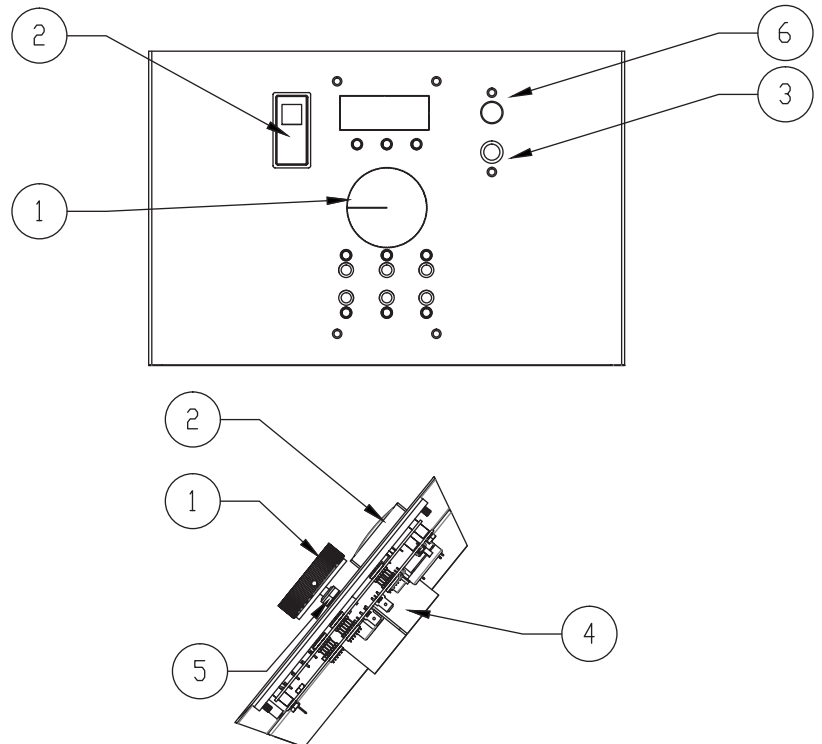

Parts List

TILT MECHANISM COMPONENTS

Ref	Description	Part #	QUANTITY			
			20 Gal	40 Gal	60 Gal	80 Gal
1	BUSHING, SNAP, 3/4" ID	000453	1	1	1	1
2	KEY, 3/8" SQUARE X 1-3/8" LONG	001474	1	1	1	1
3	SCREW, CAP, SOCKET HEAD, 3/8-16 X 1-1/2" LONG	005097	1	1	1	1
4	WASHER, LOCK, SPLIT, 3/8"	005618	1	1	1	1
5	NUT, HEX, 1/2-13	005705	4	4	4	4
6	WASHER, LOCK, 1/2"	005735	4	4	4	4
7	NUT, HEX, 3/8-16	005619	1	1	1	1
8	SCREW, CAP, HEX HEAD, 1/2-13 X 1-1/2" LONG	008679	4	4	4	4
9	ASSEMBLY, BEARING HOUSING	009762	1	1	1	-
9	ASSEMBLY, BEARING HOUSING	149788	-	-	-	1
10	BEARING, BALL	009765	2	2	2	2
11	GEAR, WORM, 3/4" BORE	012026	1	1	1	1
12	WASHER, SHIM, 1-3/8" ID	012039	2	2	2	-
13	SCREW, SET, SOCKET	012060	1	1	1	1
14	PIN, ROLL, 1/4" DIA X 1-1/4" LONG	012614	3	3	3	3
15	RING, BASIC, INTERNAL	013483	2	2	2	2
16	GEAR, 3" BORE, 92 TEETH	013609	1	1	1	1
17	HANDLE, CRANK, 3/4" BORE	013617	1	1	1	1
18	SHAFT, HANDWHEEL, 3/4" OD X 13-1/2" LONG	013624	1	1	1	-
18	SHAFT, HANDWHEEL, 3/4" OD X 20-1/2" LONG	150937	-	-	-	1
19	SPACER, 3" SCH 40 X 0.75" LONG	013625	1	1	1	-
19	SPACER, 3" SCH 40 X 2.445" LONG	150235	-	-	-	1
-	SHIM, TRUNNION	088246	1	1	1	-
-	SHIM, TRUNNION	088247	1	1	1	-
-	SPACER, WASHER	004901	1	1	1	1
-	WASHER, PLAIN, 1/2"	005049	5	5	5	5
-	ASSEMBLY, TILT SWITCH & BRACKET	135331	1	1	1	1

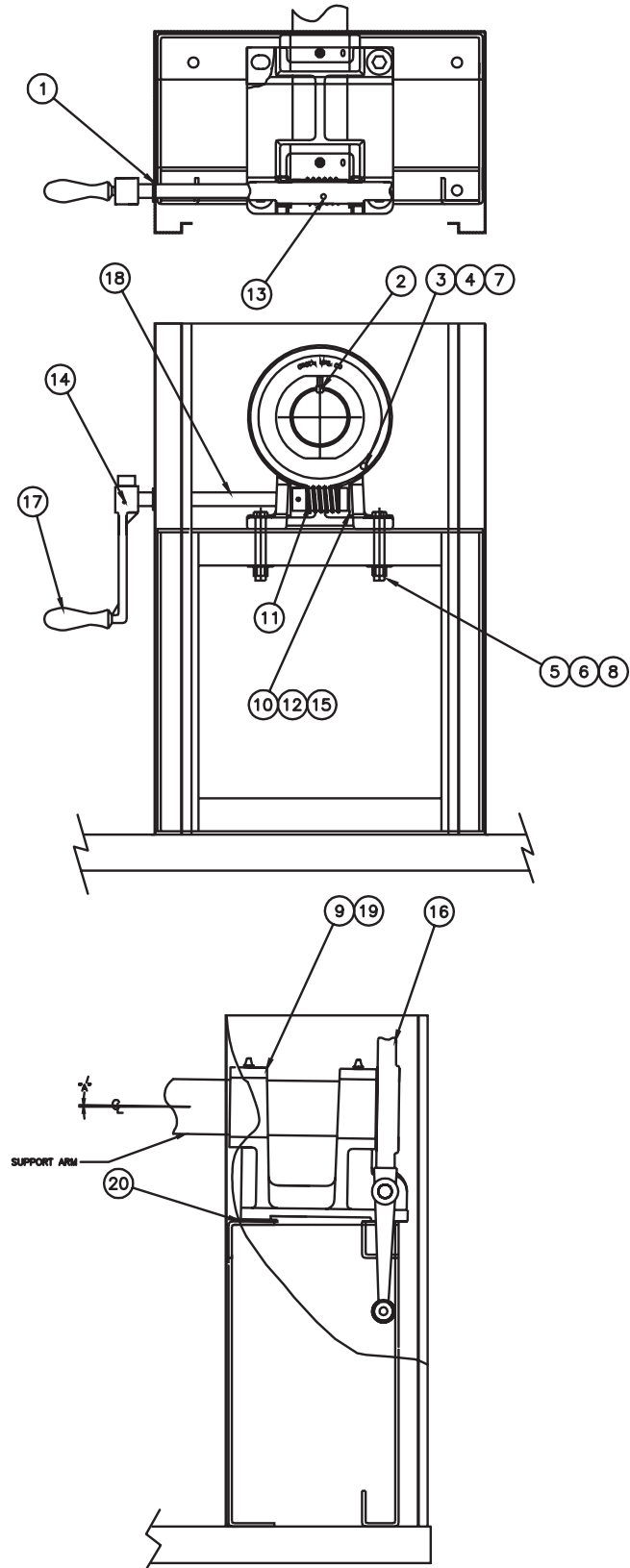

Parts List

WATER LEVEL & SAFETY VALVE COMPONENTS

Ref	Description	Part #	Qty
1	CONNECTOR MALE 1/2"	054494	2
2	COUPLING FULL 1/2" NPT	005722	1
3	SWIVEL JOINT 1/2" NPT.	076680	1
4	NIPPLE, 1/2NPT X 2-1/2" LONG	005552	3
5	1/2" X 10-1/2" NIPPLE(DH-20)	003229	1
5	NIPPLE, 1/2" NPT X 12"(DH-40)	005600	1
6	ELBOW 90 DEG 1/2" NPT	008747	2
7	NIPPLE 1/2" NPT X 3-1/2" BLK	008227	1
8	GROMMET 7/8"	007400	1
9	VALVE, GAS. 1/2"	098458	1
10	1/2" NPT TO 1/2" BSPT ADAPTER	116392	1
11	ELBOW, 90 DEG UNION 1/2" NPT	005495	1
12	FLEXIBLE TUBE, GAS 1/2" OD, 35" LONG (DH-20)	154291	1
12	40" FLEX TUBE, GAS 1/2" OD (DH-40 & DH-60)	154106	1
13	GAS VALVE - CE MARK, G31	160796	1
13	GAS VALVE - CE MARK, G20	160776	1
14	FITTING, COMPRESSION, 5/8 TUBE X 1/2 MPT	049093	2
15	TUBE, GAS PIPING, SUPPLY SIDE(DH-20)	145038	1
15	TUBE, GAS PIPING, SUPPLY SIDE(DH-40)	145040	1
15	TUBE, GAS PIPING, SUPPLY SIDE(DH-60)	145041	1
16	SEALANT, PIPE JOINT / CE	122002	0.2 OZ
17	FITTING COMPRESSION 90	004584	1
18	TUBE 1/4 OD X .032 X	006796	20 in
19	U BOLT, 1/2" PIPE	N70636	1
20	Z BOLT BRACKET	154770	1
21	NUT, HEX KEPS 1/4"-20	012940	6

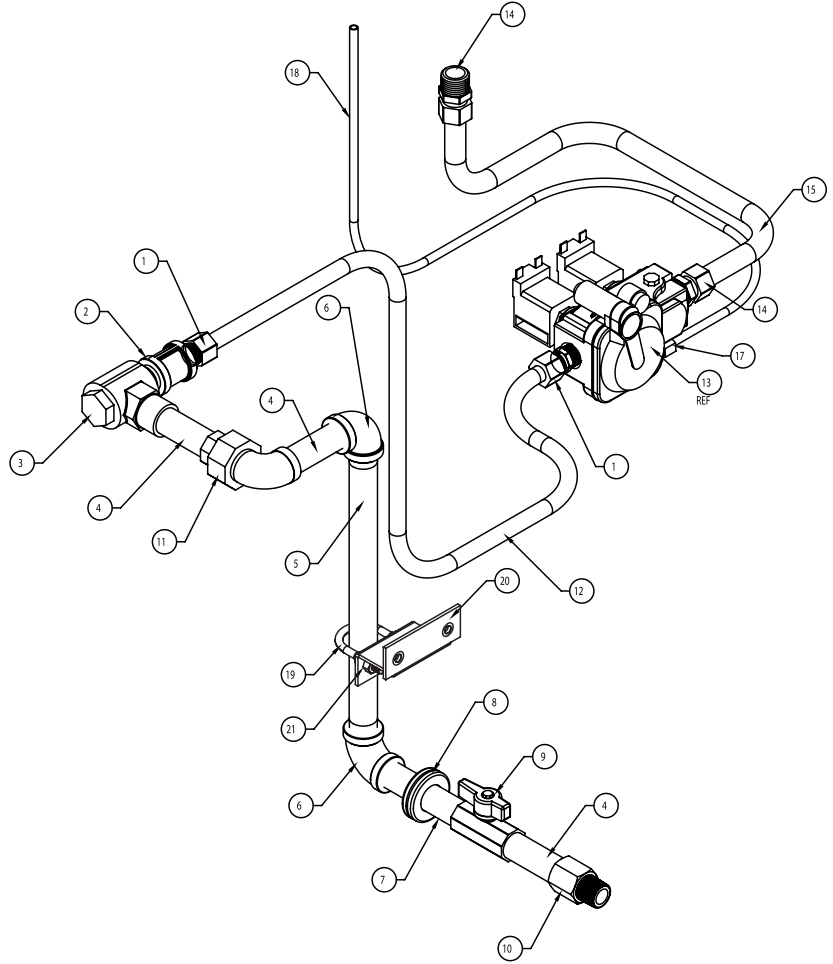

Parts List

REPLACEMENT KETTLE BODY ASSEMBLIES

Description	Part #	QUANTITY			
		20 Gal	40 Gal	60 Gal	80 Gal
REPLACEMENT KETTLE BODY ASSEMBLIES					
KBA & TRUNNION DH-20 50 PSI	175173	1	-	-	-
KBA & TRUNNION DHT-20 2" TDO 50 PSI	175174	1	-	-	-
KBA & TRUNNION DH-40 50 PSI	175179	-	1	-	-
KBA & TRUNNION DHT-40 2" TDO 50 PSI	175180	-	1	-	-
KBA & TRUNNION DH-60 50 PSI	175190	-	-	1	-
KBA & TRUNNION DHT-60 2" TDO 50 PSI	175191	-	-	1	-
KBA & TRUNNION DH-80 50 PSI	175196	-	-	-	1
KBA & TRUNNION DHT-80 2" TDO 50 PSI	175197	-	-	-	1
REPLACEMENT COMBUSTION CHAMBERS					
CHAMBER, COMBUSTION	122092	1	-	-	-
CHAMBER, COMBUSTION	122093	-	1	-	-
DIVERTER, FLUE GAS	062105	-	2	-	-
DIVERTER, FLUE GAS	062106	-	2	-	-
CHAMBER, COMBUSTION	122094	-	-	1	-
DIVERTER, CENTER PLATE, FLUE GAS	049716	-	-	2	-
DIVERTER, CENTER PLATE, FLUE GAS	049718	-	-	2	2
DIVERTER, SIDE PLATE, FLUE GAS	049717	-	-	2	2
CHAMBER, COMBUSTION	122094	-	-	-	1
DIVERTER, TOP PLATE	154028	-	-	-	1
REPLACEMENT 2" TDO VALVE COMPONENTS					
HANDLE, BLACK, 3" DIA	009029	1	1	1	1
NUT, WING, 10-24	009028	1	1	1	1
STEM, VALVE, W/COMPRESSION DISK	009048	1	1	1	1
O-RING, 7/16" ID	009034	1	1	1	1
BONNET, VALVE	009047	1	1	1	1
NUT, HEX	009354	1	1	1	1

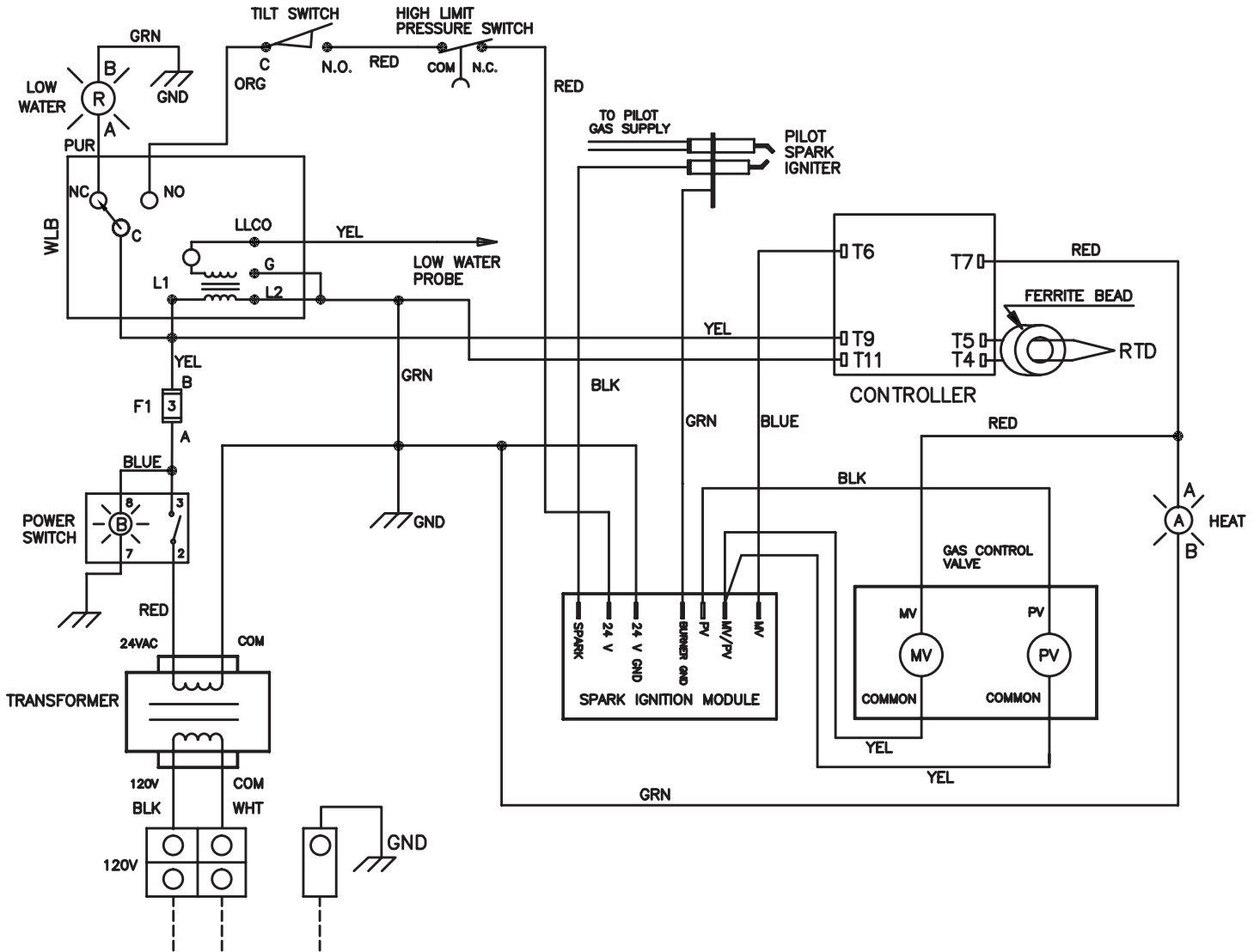

P/N 174753 REV. B

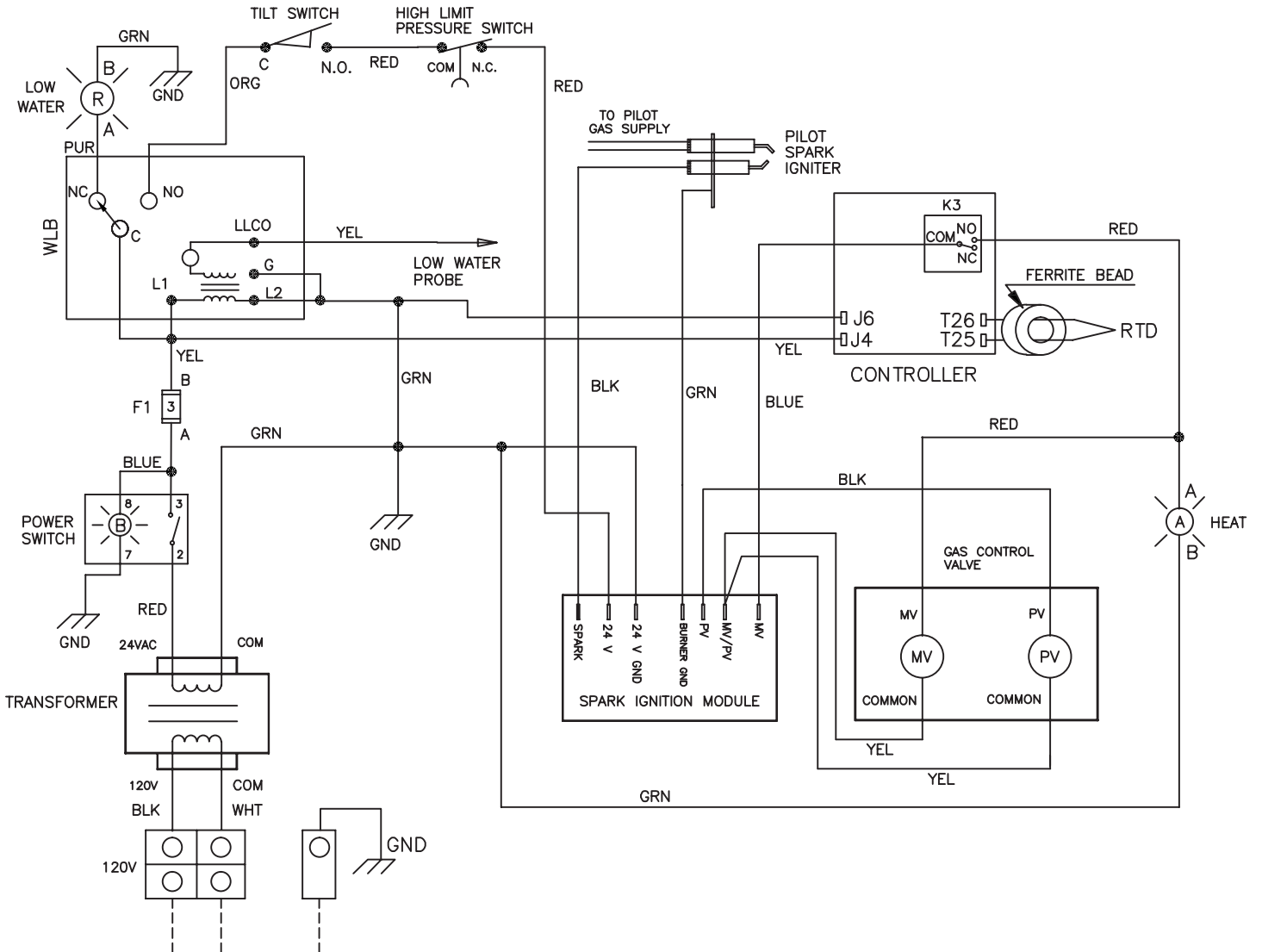

P/N 174754 REV. B

Wiring Diagram

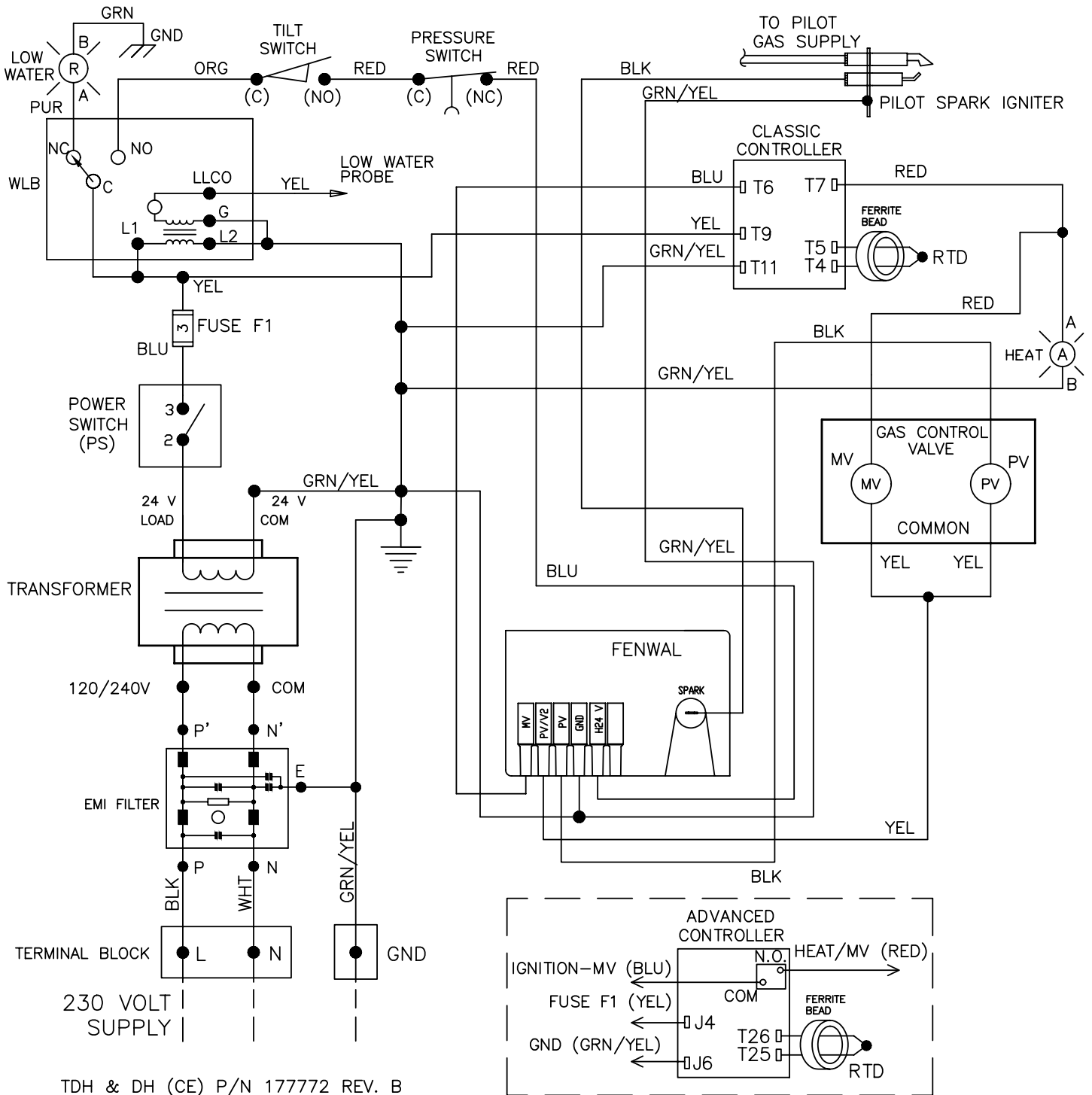

TDH & DH (CE) P/N 177772 REV. B

