



OPERATOR MANUAL

IMPORTANT INFORMATION, KEEP FOR OPERATOR

888-994-7636, fax 888-864-7636
unifiedbrands.net

THIS MANUAL MUST BE RETAINED FOR FUTURE REFERENCE. READ, UNDERSTAND AND FOLLOW THE INSTRUCTIONS AND WARNINGS CONTAINED IN THIS MANUAL.

FOR YOUR SAFETY Do not store or use gasoline or other flammable vapors and liquids in the vicinity of this or any other appliance.

WARNING Improper installation, adjustment, alteration, service or maintenance can cause property damage, injury or death. Read the installation, operating and maintenance instructions thoroughly before installing or servicing this equipment.

NOTIFY CARRIER OF DAMAGE AT ONCE It is the responsibility of the consignee to inspect the container upon receipt of same and to determine the possibility of any damage, including concealed damage. Unified Brands suggests that if you are suspicious of damage to make a notation on the delivery receipt. It will be the responsibility of the consignee to file a claim with the carrier. We recommend that you do so at once.

Manufacture Service/Questions 888-994-7636.

This manual provides information for:

STEAM JACKETED KETTLES MODELS FT, PT (2/3RD JACKETED) MODELS GT, GPT (FULL JACKETED)



PT-40 shown with optional TDO



FT-60 shown with optional TDO



GT-40 shown with optional TDO



GPT-40 shown with optional TDO

EQUIPMENT DESCRIPTION

The direct steam heated kettles covered in this manual are one-piece, welded construction of 18.8 type 304 stainless steel, which are listed by the National Sanitation Foundation. They have reinforced bar rims with a continuous seal weld on the underside. The kettles are ASME shop inspected, and registered with the national board for operation at pressures up to 25 PSI. They are finished to 180 emery grit interior, and a bright semi-deluxe exterior.

Steam from a remote source passes directly into the jacket. Steam pressure forces condensate out through the condensate outlet. The units operate safely and efficiently at steam pressures from five to 25 PSI. A safety valve works to release any pressure above the 25 PSI limit. If required, higher jacket pressure (PSI) kettles can be provided. A globe valve is required on the steam inlet, and a strainer, steam trap and check valve are needed on the condensate outlet.

The kettles are emptied by tangent draw-offs. The standard draw-off on current models is a compression disk type, fabricated from 316 stainless steel with a 2 inch outer diameter (O.D.). The draw-off has a removable stainless steel strainer which has ¼ inch perforations. Options for the draw-off include a three-inch O.D.

Models FT and PT are deep kettles with 2/3 jackets. On units with capacities of 40 gallons or less, a one-piece hinged stainless steel dome cover is furnished. On larger units the cover is counter-balanced with a Model 51 spring-assisted actuator.

Models GT and GPT are fully jacketed. All sizes are equipped with domed covers which have counter-balanced actuators.

Models FT and GT stand on stainless steel, tubular legs, that are continuously welded to the kettle. The legs are fitted with adjustable stainless steel floor flanges.

Models PT and GPT stand on a stainless steel pedestal base. The outer surface of the base is flanged down vertically to permit proper sealing to the floor or deck. These units are provided with a standard faucet bracket.

Optional equipment may include:

- TRI-BC cooking basket system
- Fill faucet with swing spout
- Gallon Master water meter
- Kettle brush kit
- Cover with No. 51 actuator (40-gallon kettle)
- Steam trap assembly



Information contained in this document is known to be current and accurate at the time of printing/creation. Reference our product line website for the most updated product information and specifications. © 2023 Electrolux Professional, Inc. All Rights Reserved.

IMPORTANT - READ FIRST - IMPORTANT

- CAUTION:** BE SURE ALL OPERATORS READ, UNDERSTAND AND FOLLOW THE OPERATING INSTRUCTIONS, CAUTIONS, AND SAFETY INSTRUCTIONS CONTAINED IN THIS MANUAL.
- WARNING:** THIS UNIT IS INTENDED FOR USE IN THE COMMERCIAL HEATING, COOKING AND HOLDING OF WATER AND FOOD PRODUCTS, PER THE INSTRUCTIONS CONTAINED IN THIS MANUAL. ANY OTHER USE COULD RESULT IN SERIOUS PERSONAL INJURY OR DAMAGE TO THE EQUIPMENT AND WILL VOID WARRANTY.
- WARNING:** KETTLE MUST BE INSTALLED BY PERSONNEL QUALIFIED TO WORK WITH ELECTRICITY. IMPROPER INSTALLATION CAN RESULT IN INJURY TO PERSONNEL AND/OR DAMAGE TO EQUIPMENT.
- DANGER:** ELECTRICALLY GROUND THE UNIT AT THE TERMINAL PROVIDED. FAILURE TO GROUND UNIT COULD RESULT IN ELECTROCUTION AND DEATH.
- WARNING:** AVOID ALL DIRECT CONTACT WITH HOT EQUIPMENT SURFACES. DIRECT SKIN CONTACT COULD RESULT IN SEVERE BURNS.
- WARNING:** AVOID ALL DIRECT CONTACT WITH HOT FOOD OR WATER IN THE KETTLE. DIRECT CONTACT COULD RESULT IN SEVERE BURNS.
- CAUTION:** DO NOT OVER FILL THE KETTLE WHEN COOKING, HOLDING OR CLEANING. KEEP LIQUIDS A MINIMUM OF 2-3" (5-8 cm) BELOW THE KETTLE BODY RIM TO ALLOW CLEARANCE FOR STIRRING, BOILING AND SAFE PRODUCT TRANSFER.
- WARNING:** TAKE SPECIAL CARE TO AVOID CONTACT WITH HOT KETTLE BODY OR HOT PRODUCT WHEN ADDING INGREDIENTS, STIRRING OR TRANSFERRING PRODUCT TO ANOTHER CONTAINER.
- WARNING:** DO NOT STAND ON OR APPLY UNNECESSARY WEIGHT OR PRESSURE ON THE KETTLE FRONT OR POURING LIP. THIS COULD RESULT IN OVERLOAD AND FAILURE OF THE TILT MECHANISM, AND POSSIBLE SERIOUS INJURY

AND BURNS TO THE OPERATOR AND OTHERS.

- CAUTION:** KEEP FLOORS IN FRONT OF KETTLE WORK AREA CLEAN AND DRY. IF SPILLS OCCUR, CLEAN IMMEDIATELY, TO AVOID SLIPS OR FALLS.
- WARNING:** FAILURE TO CHECK PRESSURE RELIEF VALVE OPERATION PERIODICALLY COULD RESULT IN PERSONAL INJURY AND/OR DAMAGE TO EQUIPMENT.
- WARNING:** WHEN TESTING, AVOID ANY EXPOSURE TO THE STEAM BLOWING OUT OF THE PRESSURE RELIEF VALVE. DIRECT CONTACT COULD RESULT IN SEVERE BURNS.
- WARNING:** TO AVOID INJURY, READ AND FOLLOW ALL PRECAUTIONS STATED ON THE LABEL OF THE WATER TREATMENT COMPOUND.
- WARNING:** BEFORE REPLACING ANY PARTS, DISCONNECT THE UNIT FROM THE ELECTRIC POWER SUPPLY.
- WARNING:** TURN OFF POWER AT THE CIRCUIT BREAKER PRIOR TO INSTALLATION OR SERVICE.
- WARNING:** ANY MECHANICAL OR ELECTRICAL CHANGE MUST BE APPROVED BY THE GROEN ENGINEERING DEPARTMENT.
- WARNING:** AVOID CONTACT WITH CLEANING PRODUCTS IN ACCORDANCE WITH SUPPLIER AND MANUFACTURER RECOMMENDATIONS. MANY CLEANERS ARE HARMFUL TO THE SKIN, EYES, MUCOUS MEMBRANES AND CLOTHING. READ THE WARNINGS AND FOLLOW DIRECTIONS ON THE CLEANER LABEL.
- WARNING:** USE OF ANY REPLACEMENT PARTS OTHER THAN THOSE SUPPLIED BY GROEN OR THEIR AUTHORIZED DISTRIBUTOR VOIDS ALL WARRANTIES AND CAN CAUSE BODILY INJURY TO THE OPERATOR AND DAMAGE TO THE EQUIPMENT.
- WARNING:** SERVICE PERFORMED BY OTHER THAN FACTORY AUTHORIZED PERSONNEL WITH VOID ALL WARRANTIES.

INSTALLATION

WARNING: THIS UNIT MUST BE INSTALLED BY PERSONNEL QUALIFIED TO WORK WITH PLUMBING. IMPROPER INSTALLATION CAN CAUSE INJURY TO PERSONNEL AND/OR DAMAGE TO EQUIPMENT.

1. Installation under a ventilation hood is recommended.
2. If the steam supply pressure is greater than the maximum working pressure stamped on the nameplate, you must install a pressure reducing valve in the steam supply line near the kettle.
3. Connect the steam supply line to the steam inlet fitting. To obtain the full heating capability of the kettle, the steam supply line must be as large as the steam inlet fitting.
4. The safety valve is preset to relieve jacket pressure that exceeds its rated limit. Do not try to adjust the valve setting, and do not allow the valve outlet or lever to be blocked.
5. Connect the kettle condensate return line to the boiler return line, or to a drain. A suitable steam trap, strainer, and check valve must be installed. (See piping diagram).
6. Any mechanical change must be approved by the Groen Food Service Engineering Department.
7. Install the unit on a level surface. Ensure that there is adequate clearance at the sides and rear, as required by the specification drawings. Anchor the pedestal or legs securely to the floor.
8. Apply a continuous bead of clear silicone sealant (No. 732 or equivalent) to the junction between the pedestal or leg flange and the surface, as shown. Fill all cracks and crevices, and wipe excess away.

INITIAL START-UP

IMPORTANT: BE SURE ALL OPERATORS READ, UNDERSTAND AND FOLLOW THE OPERATING INSTRUCTIONS, CAUTIONS, AND SAFETY INSTRUCTIONS CONTAINED IN THIS MANUAL.

WARNING: AVOID EXPOSURE TO ESCAPING STEAM, WHICH CAN CAUSE SEVERE BURNS.

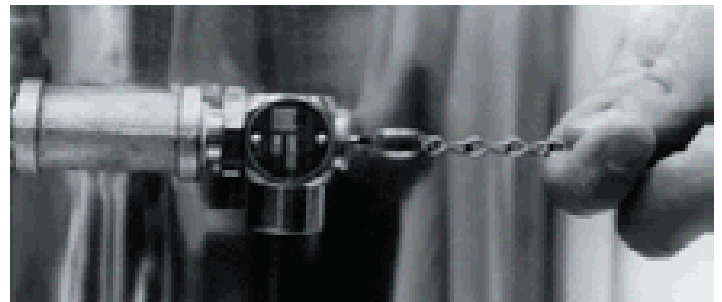

- Test the safety valve each day -



Now that the kettle has been installed, you should test it to ensure that it is operating correctly.

1. Remove all literature and packing materials from inside and outside of the unit.
2. Pour a small amount of water into the kettle.
3. Open the steam inlet valve.
4. When the water begins to boil, inspect all of the fittings to ensure that there are no leaks.
5. Check the safety valve by pulling out on its chain, (or lifting its lever on older models) far enough to let steam escape. Then let it snap back into place to reseal the valve so that it will not leak.

- Shut down the unit by closing the steam inlet valve.
- Operate the drawoff valve to ensure that it functions across the normal range of operation. If the unit functions as described above, it is ready for use.

If the unit does not function as intended, contact your local Groen Authorized Service Agency.

OPERATION

WARNING: AVOID EXPOSURE TO ESCAPING STEAM, WHICH CAN CAUSE SEVERE BURNS.

WARNING: AVOID ALL DIRECT CONTACT WITH HOT FOOD OR WATER IN THE KETTLE. DIRECT CONTACT COULD RESULT IN SEVERE BURNS.

TAKE SPECIAL CARE TO AVOID CONTACT WITH HOT KETTLE BODY OR HOT PRODUCT, WHEN ADDING INGREDIENTS, STIRRING OR TRANSFERRING PRODUCT TO ANOTHER CONTAINER.

CAUTION: DO NOT OVERFILL THE KETTLE WHEN COOKING, HOLDING OR CLEANING. KEEP LIQUIDS AT LEAST 2-3" (5-8 CM) BELOW THE KETTLE BODY RIM TO ALLOW CLEARANCE FOR STIRRING, BOILING PRODUCT AND SAFE TRANSFER.



To heat the kettle, open the condensate return valve and the steam inlet valve. Adjusting the inlet valve allows the operator to control the heating rate. Opening the valve more allows steam to flow into the jacket faster, and thereby heats the product faster.

The kettle operates efficiently with steam pressures from five PSI to the maximum working pressure for which the kettle was designed. The maximum allowable pressure (normally 25 PSI for standard units) is stamped on the kettle nameplate.

Once a day, while there is still steam pressure in the jacket, bleed off any entrapped air and double check the operation of the safety valve. Pull out on its chain, (or lift the lever on older models) far enough to let steam escape. Then let it snap back into place to reseal the valve so that it will not leak.

SEQUENCE OF OPERATION

The following "action-reaction" outline is provided to help you understand how the equipment functions.

When the steam inlet valve is opened, steam flows into the jacket at a pressure determined by the boiler system, or by the pressure reducing valve which serves the kettle. In the jacket steam releases its heat to the kettle as it condenses into water. The steam trap allows condensate (water) to leave the kettle while holding the steam in.

When the steam supply is shut off, condensation of the remaining steam produces a vacuum in the jacket, but the check valve in the condensate return line keeps water from flowing back into the jacket.

CLEANING

CAUTION: MOST CLEANERS ARE HARMFUL TO THE SKIN, EYES, MUCOUS MEMBRANES, AND CLOTHING. PRECAUTIONS SHOULD BE TAKEN. WEAR RUBBER GLOVES, GOGGLES OR FACE SHIELD, AND PROTECTIVE CLOTHING. READ THE WARNINGS AND FOLLOW THE DIRECTIONS ON THE LABEL OF THE CLEANER CAREFULLY.

WARNING: AVOID ANY DIRECT CONTACT WITH HOT SURFACES. DIRECT SKIN CONTACT COULD RESULT IN SEVERE BURNS.

CAUTION: DO NOT MIX DIFFERENT KETTLE DRAW-OFF ASSEMBLY PARTS WHEN WASHING. THEY ARE NOT INTERCHANGEABLE.

NOTICE: NEVER LEAVE A CHLORINE SANITIZER IN CONTACT WITH STAINLESS STEEL SURFACES LONGER THAN 30 MINUTES. LONGER CONTACT CAN CAUSE STAINING AND CORROSION.

SUGGESTED TOOLS

- Cleaner, such as Klenzade HC-10 or HC-32 from ECOLAB, Inc.
- Long- and short-handled kettle brushes in good condition.
- Brush suitable for cleaning the draw-off port.
- Sanitizer such as Klenzade XY-12.
- Film remover such as Klenzade LC-30.

PROCEDURE

- Clean food-contact surfaces as soon as possible after use, preferably while the kettle is warm. If the unit is in continuous use, thoroughly clean and sanitize the interior and exterior at least once every 12 hours.
- Scrape and flush out food residues with lukewarm water. After flushing the kettle, close the draw-off valve.
- Prepare a hot solution of the detergent/ cleaning compound as instructed by the supplier. Set some of this solution aside to use in cleaning the draw-off valve and pipe.
- Clean the unit thoroughly, inside and outside.
- Drain the kettle.
- Disassemble the tangent draw-off valve. Clean the draw-off pipe and each valve part with a brush.
- Rinse the kettle and draw-off parts thoroughly with warm water, then drain completely.
- As part of the daily cleaning, clean all external and internal surfaces that may have been soiled. Remember to check such areas as the underside of the cover.
- To remove burned-on materials, use a brush, sponge, cloth, plastic or rubber scraper, or plastic wool with the cleaning solution. To reduce effort required in washing, let the detergent solution sit in the kettle and soak into the residue. Do not use abrasive materials or metal tools that might scratch the surface. Scratches make the surface harder to clean and provide places for bacteria to grow.
- Do not use steel wool, which may leave particles in the surface and cause eventual corrosion and pitting.

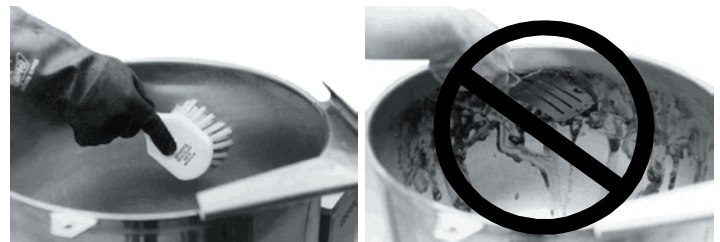

- Use brushes, sponges or cloth to clean your kettles.
Don't scrape with tools, steel wool or other abrasives. -

- The outside of the unit may be polished with a stainless steel cleaner such as "Zepper" from Zep Manufacturing Co.
- When equipment needs to be sanitized, use a solution equivalent to one that supplies 200 parts per million available chlorine. Obtain advice on sanitizing agents from your supplier of sanitizing products. Following the supplier's instructions, apply the agent after the unit has been cleaned and drained. Drain and thoroughly rinse off the sanitizer.
- It is recommended that each piece of equipment be sanitized just before use.
- If there is difficulty removing mineral deposits or a film left by hard water or food residues, clean the kettle thoroughly and use a deliming agent, like Groen Delimer/Descaler (Part Number 114800) or Lime-Away® from Ecolab, in accordance with the manufacturer's directions. Rinse and drain the unit thoroughly before further use.
- If cleaning problems persist, contact your cleaning product representative for assistance. The supplier has a trained technical staff with laboratory facilities to serve you.

MAINTENANCE

WARNING: WHEN TESTING, AVOID ANY EXPOSURE TO THE STEAM BLOWING OUT OF THE SAFETY VALVE. DIRECT CONTACT COULD RESULT IN SEVERE BURNS.

NOTE: SERVICE PERFORMED BY OTHER THAN FACTORY- AUTHORIZED PERSONNEL WILL VOID ALL WARRANTIES.

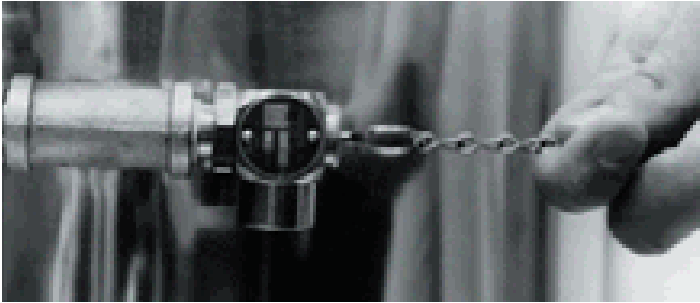

- Test the safety valve each day -

PERIODIC MAINTENANCE

A Maintenance & Service Log is provided at the back of this manual. Each time maintenance is performed on your Groen kettle, enter the date on which the work was done, what was done, and who did it. Keep this manual on file and available for operators to use.

Periodic inspection will minimize equipment down time and increase the efficiency of operation. The following points should be checked:

Once a day, with pressure in the jacket, check the operation of the pressure relief safety valve. Pull the chain of the safety valve until steam is released. Then release the chain and let the valve snap shut. If the lever does not activate, or there is no evidence of discharge, or the valve leaks, immediately discontinue use of the kettle and contact a qualified Groen service representative.

At least once every 90 days, inspect fittings and valves for signs of damage or wear.

REFERENCES

KLENZADE SALES CENTER, ECOLAB. Inc.
370 Wabasha
St. Paul, Minnesota 55102
800/352-5326 or 612/293-2233

NSF INTERNATIONAL
789 N. Dixboro Rd.
P.O. Box 130140
Ann Arbor, Michigan 48113-0140

ZEP MANUFACTURING CO.
1310-T Seaboard Industrial Blvd.
Atlanta, Georgia 30318

REPLACEMENT PARTS

To order parts, contact your Authorized Service Agent. Supply the model designation, serial number, part description, part number, quantity, and when applicable, voltage and phase.

CONTACT US

If you have questions pertaining to the content in this manual, contact Groen at 888-994-7636.

TROUBLESHOOTING

WARNING: USE OF ANY REPLACEMENT PARTS OTHER THAN THOSE SUPPLIED BY GROEN OR THEIR AUTHORIZED DISTRIBUTORS CAN CAUSE INJURY TO THE OPERATOR AND DAMAGE TO THE EQUIPMENT AND WILL VOID ALL WARRANTIES.

Your Groen kettle will operate smoothly and efficiently if properly maintained. However, the following is a list of checks to make in the event of a problem. If the actions suggested do not solve the problem, call Groen technical service or a Groen Authorized Service Agent. For the phone number of the nearest agency, call your area Groen representative or the Groen Parts and Service Department. If an item on the list is followed by •, the work should be done by a Groen Authorized Service Agent or a Groen qualified service representative.

SYMPTOM	WHO	WHAT TO CHECK
Kettle will not heat.	User	a. That the steam inlet valve is open. b. That the steam supply line is turned on. c. That the condensate return valve is open. d. That the boiler is operating properly. Steam should be supplied at a pressure greater than five PSI.
	Auth Service Rep Only	e. Steam supply line for blockage. • f. Condensate return line for blockage. • g. Steam trap operation. •
Safety valve leaks a small amount of steam.	User	a. For contamination that prevents seating the valve. With substantial pressure in the jacket, lift the valve lever briefly all the way up, to blow the valve clean then let it snap back down to seat the valve.
	Auth Service Rep Only	b. Safety valve for defects. Defective valve MUST be replaced with a valve rated at the same pressures. •
Safety valve leaks a large amount of steam.	Auth Service Rep Only	a. Steam supply pressure. • b. Safety valve for defects. Defective valve MUST be replaced with a valve rated at the same pressures. •
Pipe fitting leaks.	User	a. Is the fitting tight?
	Auth Service Rep Only	b. If tightening the packing gland does not stop the leak, replace the packing. •

PARTS LIST

MODELS FT & PT, 10-40 GALLON INCLUSIVE

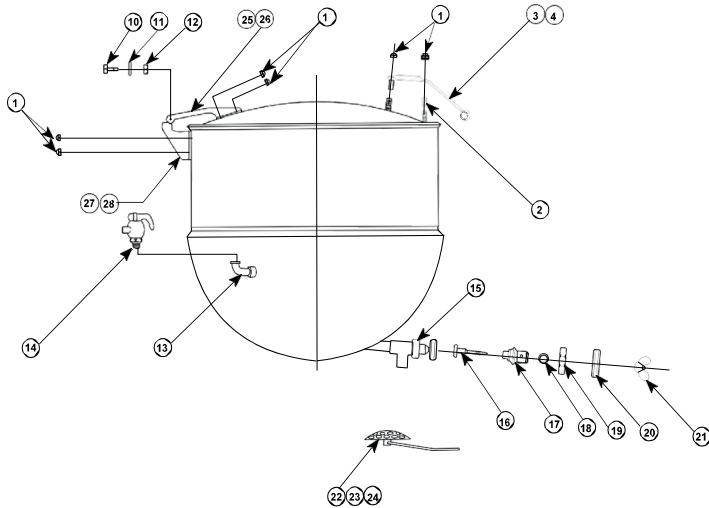

MODEL GPT 20

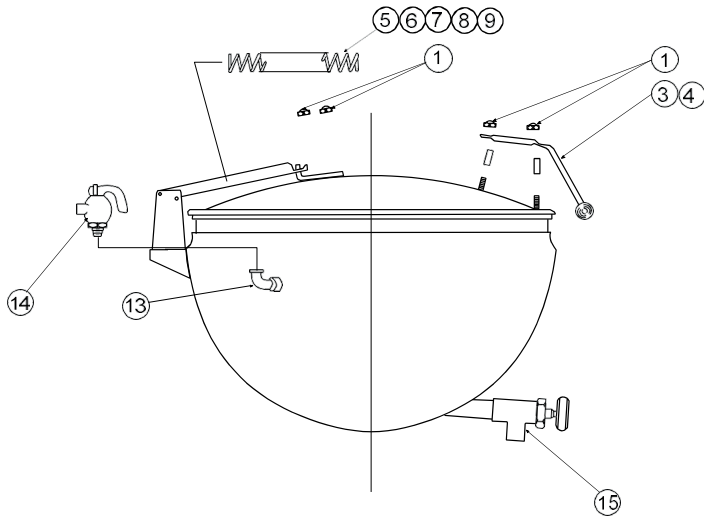

MODELS FT & PT, 60 GALLONS AND LARGER MODELS GT & GPT, 25 GALLONS AND LARGER

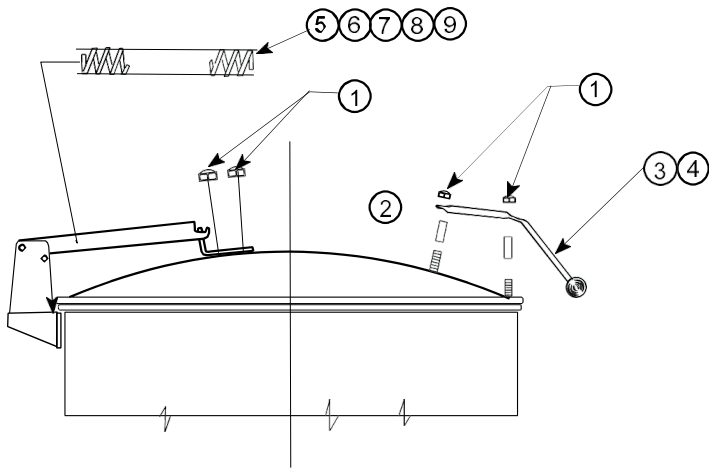

ITEM	DESCRIPTION	PART NO.
1	1/4"-20 N.C. CAP NUT	005471
2	SPACER	012733
3	HANDLE (COVERS W/ACTUATOR)*	047712
3	COVER ACTUATOR	120521
3	COVER HANDLE	120915
3	U-HANDLE	010245
4	KNOB (FRICTION)	012691
5	SPRING (28" & 30" COVERS)	012303
6	SPRING (32" & 36" COVERS)	012413
7	SPRING (38" & 42" COVERS)	012533
8	SPRING (44" & 48" COVERS)	012565
9	SPRING (50" COVERS)	012566
10	1/2"-20 N.F. X 1" LG HEX HD CAPSCR.	002212
11	1/2" BRASS WASHER	002213
12	1/2"-20 N.F. JAM NUT	010668
13	3/4" I.P.S. STREET ELBOW	011004
14	#25-3/4" SAFETY VALVE	011004
15	1 1/2" DRAW-OFF VALVE COMPLETE	009000
15	1 1/2" DRAW-OFF TUBE	010632
15	2" DRAW-OFF VALVE COMPLETE	009046
15	2" DRAW-OFF TUBE	038418
15	3" DRAW-OFF VALVE COMPLETE	012262
16	STEM FOR 1-1/2" VALVE	009027
16	STEM FOR 2" VALVE	009048
16	STEM FOR 3" VALVE	001908
17	BONNET FOR 1 1/2" VALVE	009024
17	BONNET FOR 2" VALVE	009047
17	BONNET FOR 3" VALVE	003925
18	O-RING FOR 1 1/2" & 2" VALVES	009034
19	HEX NUT 1 1/2" VALVE	008911
19	HEX NUT 2" VALVE	009354
19	HEX NUT 3" VALVE	003927
20	HANDLE FOR 1 1/2" & 2" VALVES	009029
20	HANDLE FOR 3" VALVE	012209
21	WING NUT FOR 1 1/2" & 2" VALVES	009028
24	STRAINER, 1/4" PER.	009986
25	R.H. COVER HINGE	002292
26	L.H. COVER HINGE	002293
27	R.H. HINGE HALF	012877
28	L.H. HINGE HALF	012878

PIPING DIAGRAM

BUCKET TYPE STEAM TRAP ASSEMBLY

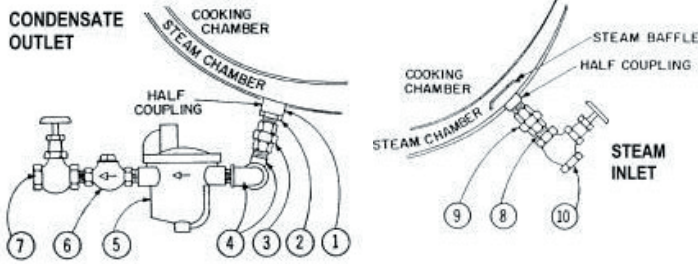

ITEM	DESCRIPTION
1	BUSHING
2	CLOSE NIPPLE
3	FEMALE UNION
4	STREET ELBOW
5	BUCKET STEAM TRAP
6	SWING CHECK VALVE
7	GATE VALVE
8	GLOBE VALVE
9	CLOSE NIPPLE
10	FEMALE UNION

* All of the fittings illustrated are required for proper and safer installation and operation, and are NOT PROVIDED as standard with the unit. Steam trap assemblies are available from Groen and can be purchased in two versions.

1. COMPLETELY PIPED - Complete, preassembled, with nipples and fittings, as shown in the diagram
2. LOOSE - Unassembled, without nipples and fittings, but includes steam trap, check valve, globe valve and gate valve.

NOTE: All steam trap assemblies are shipped in a separate container and are not mounted on the kettle to prevent damage during shipment. A steam pressure reducing valve (PRV) is available at extra cost for installation when steam pressure exceeds the kettle's maximum working pressure. It is to be mounted on the steam inlet side, just before the steam valve (globe valve), as close to the kettle as possible.

INLET SIZE	OUTLET SIZE	USED ON	PART NUMBER		
			STANDARD FINISH	ROUGH CHR. PLT.	POL. CHR. PLT.
1/2" I.P.S	1/2" I.P.S	FT - 10, 20 & 30 PT - 10, 20 & 30	025373	044884	062999
3/4" I.P.S	1/2" I.P.S	FT - 40 & 60 PT - 40 & 60 GT - 20 & 25 GPT - 20 & 25	025374	040618	040624
1" I.P.S	3/4" I.P.S	FT - 80 & 100 PT - 80 & 100 GT - 40, 50, 60, 80, 100 GPT - 40, 50, 60, 80, 100	025923	065788	054149

THERMOSTATIC TYPE STEAM TRAP ASSEMBLY

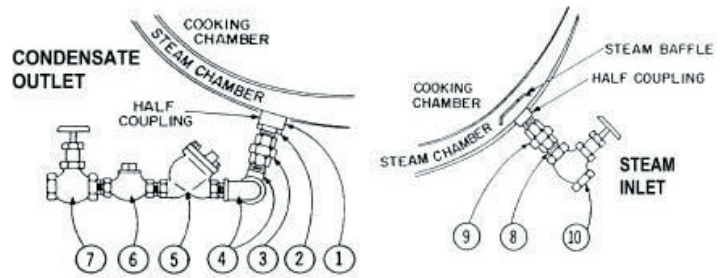

ITEM	DESCRIPTION
1	BUSHING
2	CLOSE NIPPLE
3	FEMALE UNION
4	STREET ELBOW
5	THERMOSTATIC STEAM TRAP
6	SWING CHECK VALVE
7	GATE VALVE
8	CLOSE NIPPLE
9	FEMALE UNION
10	GLOBE VALVE

* All of the fittings illustrated are required for proper and safer installation and operation, and are NOT PROVIDED as standard with the unit. Steam trap assemblies are available from Groen and can be purchased in two versions.

1. COMPLETELY PIPED - Complete, preassembled, with nipples and fittings, as shown in the diagram
2. LOOSE - Unassembled, without nipples and fittings, but includes steam trap, check valve, globe valve and gate valve.

NOTE: All steam trap assemblies are shipped in a separate container and are not mounted on the kettle to prevent damage during shipment. A steam pressure reducing valve (PRV) is available at extra cost for installation when steam pressure exceeds the kettle's maximum working pressure. It is to be mounted on the steam inlet side, just before the steam valve (globe valve), as close to the kettle as possible.

INLET SIZE	OUTLET SIZE	USED ON	PART NUMBER		
			STANDARD FINISH	ROUGH CHR. PLT.	POL. CHR. PLT.
1/2" I.P.S	1/2" I.P.S	FT - 10, 20 & 30 PT - 10, 20 & 30	045171	059473	090530
3/4" I.P.S	1/2" I.P.S	FT - 40 & 60 PT - 40 & 60 GT - 20 & 25 GPT - 20 & 25	041065	050948	040685
1" I.P.S	3/4" I.P.S	FT - 80 & 100 PT - 80 & 100 GT - 40, 50, 60, 80, 100 GPT - 40, 50, 60, 80, 100	045171	048763	040686

