

OPERATOR MANUAL

IMPORTANT INFORMATION, KEEP FOR OPERATOR

This manual provides information for:

MODELS

HFP/2E & HFP/2 *Domestic*

BRAISING PAN

- Stainless Steel
- Manual Tilt
- Gas Heated



THIS MANUAL MUST BE RETAINED FOR FUTURE REFERENCE. READ, UNDERSTAND AND FOLLOW THE INSTRUCTIONS AND WARNINGS CONTAINED IN THIS MANUAL.

FOR YOUR SAFETY

Do not store or use gasoline or other flammable vapors and liquids in the vicinity of this or any other appliance.

POST IN A PROMINENT LOCATION

Instructions to be followed in the event user smells gas. This information shall be obtained by consulting your local gas supplier. As a minimum, turn off the gas and call your gas company and your authorized service agent. Evacuate all personnel from the area.

WARNING

Improper installation, adjustment, alteration, service or maintenance can cause property damage, injury or death. Read the installation, operating and maintenance instructions thoroughly before installing or servicing this equipment.

NOTIFY CARRIER OF DAMAGE AT ONCE

It is the responsibility of the consignee to inspect the container upon receipt of same and to determine the possibility of any damage, including concealed damage. Unified Brands suggests that if you are suspicious of damage to make a notation on the delivery receipt. It will be the responsibility of the consignee to file a claim with the carrier. We recommend that you do so at once.

Manufacture Service/Questions 888-994-7636.

Information contained in this document is known to be current and accurate at the time of printing/creation. Unified Brands recommends referencing our product line websites, unifiedbrands.net, for the most updated product information and specifications.

PART NUMBER 121023, REV. C (01/03)

GROEN®



1055 Mendell Davis Drive
Jackson, MS 39272
888-994-7636, fax 888-864-7636
groen.com

IMPORTANT — READ FIRST — IMPORTANT

- CAUTION:** SHIPPING STRAPS ARE UNDER TENSION AND CAN SNAP BACK WHEN CUT.
- CAUTION:** UNIT WEIGHS 370 TO 560 LB. (165 TO 255 KG). FOR SAFE HANDLING, INSTALLER SHOULD OBTAIN HELP AS NEEDED, OR EMPLOY APPROPRIATE MATERIALS HANDLING EQUIPMENT (SUCH AS A FORKLIFT, DOLLY, OR PALLET JACK) TO REMOVE THE UNIT FROM THE SKID AND MOVE IT TO THE PLACE OF INSTALLATION.
- WARNING:** INSTALLATION OF THE BRAISING PAN MUST BE DONE BY PERSONNEL QUALIFIED TO WORK WITH GAS AND ELECTRICITY. IMPROPER INSTALLATION CAN RESULT IN INJURY TO PERSONNEL AND/OR DAMAGE TO EQUIPMENT.
- WARNING:** THIS UNIT IS DESIGNED FOR COMMERCIAL USE. NEVER USE HOME OR RESIDENTIAL GRADE GAS CONNECTIONS. THEY DO NOT MEET GAS CODES AND COULD BE HAZARDOUS.
- DANGER:** ELECTRICALLY GROUND THE UNIT AT THE TERMINAL PROVIDED. FAILURE TO GROUND UNIT COULD RESULT IN ELECTROCUTION AND DEATH.
- WARNING:** KEEP THE APPLIANCE AREA FREE AND CLEAR OF COMBUSTIBLE MATERIALS.
- CAUTION:** BE SURE ALL OPERATORS READ, UNDERSTAND AND FOLLOW THE OPERATING INSTRUCTIONS, CAUTIONS AND SAFETY INSTRUCTIONS CONTAINED IN THIS MANUAL.
- CAUTION:** KEEP FLOORS IN BRAISING PAN WORK AREA CLEAN AND DRY. IF SPILLS OCCUR, CLEAN IMMEDIATELY TO AVOID THE DANGER OF SLIPS OR FALLS.
- WARNING:** WHEN TILTING BRAISING PAN FOR PRODUCT TRANSFER:
- 1) USE CONTAINER DEEP ENOUGH TO CONTAIN AND MINIMIZE PRODUCT SPLASHING.
 - 2) PLACE CONTAINER ON STABLE, FLAT SURFACE, AS CLOSE TO PAN AS POSSIBLE.
 - 3) STAND TO SIDE OF PAN WHILE POURING — NOT DIRECTLY IN POUR PATH OF HOT CONTENTS.
 - 4) RETURN PAN BODY TO LEVEL POSITION AFTER CONTAINER IS FILLED OR TRANSFER IS COMPLETE.
 - 5) DO NOT OVER FILL CONTAINER. AVOID DIRECT SKIN CONTACT WITH HOT CONTAINER AND ITS CONTENTS.
- WARNING:** DO NOT HEAT EMPTY PAN FOR MORE THAN 5 MINUTES AT A SETTING HIGHER THAN 300°F.
- WARNING:** IF THE PAN CONTAINS ITEMS IN SAUCE OR MELTED FAT, THEY CAN SLIDE FORWARD SUDDENLY DURING TILTING AND CAUSE THE HOT LIQUID TO SPLASH OUT.
- WARNING:** AVOID ALL DIRECT CONTACT WITH HOT FOOD OR WATER IN THE PAN. DIRECT CONTACT COULD RESULT IN SEVERE BURNS.
- WARNING:** KEEP WATER AND SOLUTIONS OUT OF CONTROLS AND BURNERS. NEVER SPRAY OR HOSE THE CONTROL CONSOLE, OR ELECTRICAL CONNECTIONS.
- CAUTION:** MOST CLEANERS ARE HARMFUL TO THE SKIN, EYES, MUCOUS MEMBRANES AND CLOTHING. PRECAUTIONS SHOULD BE TAKEN TO WEAR RUBBER GLOVES, GOGGLES OR FACE SHIELD AND PROTECTIVE CLOTHING. CAREFULLY READ THE WARNINGS AND FOLLOW THE DIRECTIONS ON THE LABEL OF THE CLEANER TO BE USED.
- WARNING:** THE CONTROL BOX IS NOT WATERPROOF. TAKE CARE TO KEEP WATER AND CLEANING SOLUTIONS OUT OF THE BOX. NEVER HOSE OR SPRAY ELECTRICAL CONTROLS, CONNECTIONS OR CONTROL CONSOLE.
- WARNING:** BEFORE REPLACING ANY PARTS, DISCONNECT THE UNIT FROM THE ELECTRIC POWER SUPPLY AND CLOSE THE MAIN GAS COCK. ALLOW FIVE MINUTES FOR UNBURNED GAS TO VENT.
- CAUTION:** USE OF ANY REPLACEMENT PARTS OTHER THAN THOSE SUPPLIED BY GROEN OR AUTHORIZED DISTRIBUTORS CAN CAUSE INJURY TO THE OPERATOR AND DAMAGE TO THE EQUIPMENT AND WILL VOID ALL WARRANTIES.
- IMPORTANT:** Service performed by other than factory authorized personnel will void all warranties.

Table of Contents

| | |
|--|----|
| IMPORTANT OPERATOR WARNINGS (READ FIRST) | 2 |
| REFERENCES | 3 |
| EQUIPMENT DESCRIPTION | 4 |
| INSPECTION AND UNPACKING | 5 |
| INSTALLATION | 6 |
| INITIAL START-UP | 7 |
| OPERATION | 7 |
| SEQUENCE OF OPERATION | 9 |
| CLEANING | 10 |
| MAINTENANCE | 12 |
| TROUBLESHOOTING | 12 |
| PARTS LIST | 15 |
| DIAGRAMS & SCHEMATICS | 24 |
| MAINTENANCE LOG | 26 |
| WARRANTY | 27 |

References

American Gas Association Laboratories
8501 East Pleasant Valley Rd.
Cleveland, Ohio 44131

Z223.1-1984 National Fuel Gas Code

American National Standards Institute
1403 Broadway
New York, New York 10018

Canadian Gas Association
55 Scarsdale Road
Don Mills, Ontario M3B 2 R3

ECOLAB, INC.
370 Wabasha
St. Paul, Minnesota 55102

National Fire Protection Association
60 Battery March Park
Quincy, Massachusetts 02269

*NFPA/54 Installation of Gas Appliances &
Gas Piping*
NFPA/70 The National Electrical Code
NFPA/96 Ventilating Hoods

National Sanitation Foundation
3475 Plymouth Road
Ann Arbor, Michigan 48106

Underwriters Laboratories, Inc.
333 Pfingsten Road
Northbrook, Illinois 60062

ZEP Manufacturing
1390 Lunt Avenue
Elk Grove Village, Illinois 60007

OM-HFP

Equipment Description

Groen Gas Heated Braising Pans provide a stainless steel pan equipped with patented heat transfer fins, burner/combustion chamber, hand-operated tilting mechanism, thermostatic controls, and hinged cover. The Braising Pan serves as braising unit, griddle, fry pan, oven, kettle, bain-marie, or food warmer and server, and it can be adapted for use as a steamer.

The pan body is made from heavy-duty stainless steel welded into one solid piece, with a polished interior and exterior. A pouring lip is welded to the front wall. The cooking surface is a stainless steel clad plate fitted with welded heat transfer fins which assure uniform heat transfer over the entire surface. The gas burner/combustion chamber supplies the heat.

An easily operated worm and gear mechanism tilts the pan and provides precise control for pouring or dumping the contents of the pan. This hand-wheel controlled mechanism is located in a stainless steel console to the right of the pan body. To assist cleaning, the pan body can be tilted past the vertical position. When the pan is tilted, the burners shut off automatically.

The thermostat provides automatic control of cooking temperature. Operating the thermostat dial on the front of the control console turns the heat on or off and sets the pan temperature.

A vented, heavy gauge, one-piece, stainless steel cover with a condensate drip shield on the rear edge is standard on the Braising Pan. A fully enclosed, spring type actuator counter-balances the cover to keep it in either the opened or closed position. The cover opens to the back and is hinged to the frame, so it moves independently of the pan body.

Models HFP/2E, and HFP/2 are mounted on an open-leg frame fabricated from tubular stainless steel.

Model HFP/2E has an ignition system that uses electronic spark ignition. Optional model HFP/2 has a standing-flame pilot light that ignites the main burner.

| Model | Pan Dimensions | | Ignition |
|----------|----------------|------------|----------|
| | L to R | Depth | |
| HFP/2E-2 | 24e" (62.5cm) | 9" (23cm) | Spark |
| HFP/2-2 | 24e" (62.5 cm) | 9" (23cm) | Flame |
| HFP/2E-3 | 31e" (80 cm) | 9" (23cm) | Spark |
| HFP/2-3 | 31e" (80 cm) | 9" (23cm) | Flame |
| HFP/2E-4 | 41e" (1.06m) | 9" (23cm) | Spark |
| HFP/2-4 | 41e" (1.06m) | 9" (23cm) | Flame |

Options available with these models are:

1. Fill faucet with swing spout. (Left or right mounted)
2. Caster mounting kit.
3. Fold-down work tray (pan support) mounted on left or right side.
4. 2" Tangent draw-off (Factory-installed option)
5. Model REJ Steamer Insert set.
6. Steamer Pan Carrier.
7. Quick gas disconnect with restraining cable.



Optional Tangent Draw-Off

Performance Data

| MODELS | FIRING RATE |
|-------------------|----------------|
| HFP/2-2, HFP/2E-2 | 80,000 BTU/hr |
| HFP/2-3, HFP/2E-3 | 104,000 BTU/hr |
| HFP/2-4, HFP/2E-4 | 144,000 BTU/hr |

Inspection and Unpacking

The unit will arrive completely assembled, wrapped in protective plastic on a heavy skid, in a heavy cardboard carton. Immediately upon receipt, inspect the carton for damage. Report any apparent shipping damage or an incorrect shipment to the delivery agent.

When installation is to begin, get someone to assist in removing the carton. Lift it straight up and away from the unit. **Do not simply raise it and push backwards - you will break the cover assembly vent handle.** Write down the model number, serial number, and installation date of your unit, and keep this information for future reference. Space for these entries is provided at the top of the Service Log in this manual.

Cut the straps holding the unit on the skid, and lift the unit straight up off the skid.

CAUTION
SHIPPING STRAPS ARE UNDER TENSION AND CAN SNAP BACK WHEN CUT.

UNIT WEIGHS 370 TO 560 LB (170 TO 255 KG). FOR SAFE HANDLING, INSTALLER SHOULD OBTAIN HELP AS NEEDED, OR EMPLOY APPROPRIATE MATERIALS HANDLING EQUIPMENT (SUCH AS A FORKLIFT, DOLLY, OR PALLET JACK) TO REMOVE THE UNIT FROM THE SKID AND MOVE IT TO THE PLACE OF INSTALLATION.



The unit is strapped to a skid, and shipped in a heavy cardboard carton.

Installation

Install the Braising Pan in a well ventilated room for efficient performance. Remove any items which might obstruct or restrict the flow of air for combustion and ventilation. Clear all combustible material from the area directly around the unit.

WARNING
INSTALLATION OF THE BRAISING PAN MUST BE DONE BY PERSONNEL QUALIFIED TO WORK WITH GAS AND ELECTRICITY. IMPROPER INSTALLATION CAN RESULT IN INJURY TO PERSONNEL AND/OR DAMAGE TO EQUIPMENT.

1. Installation on combustible floors is allowed. Ensure minimum clearance to combustible and noncombustible construction of six inches at the rear, zero inches at the sides.
2. Install the unit under a vent hood.
3. Level the unit by adjusting the bullet feet or floor flanges on the legs. Be sure the tilting mechanism has been turned all the way to the horizontal position. Check levelness with a spirit level set on the bottom of the pan body. Anchor the rear legs securely to the floor if floor flanges are ordered or required.
4. Complete piping to the gas service with 3/4" inch IPS pipe or approved equivalent.

WARNING:
THIS UNIT IS FOR COMMERCIAL USE. NEVER USE HOME OR RESIDENTIAL GRADE GAS CONNECTIONS. THEY DO NOT MEET GAS CODES AND COULD BE HAZARDOUS.

5. For a unit on casters, complete connection to the gas supply with connectors that comply with the standard for Connectors for Moveable Gas Appliances, ANSI Z21.69a-latest edition. Restrain movement of the unit by attaching a cable or chain to the eyelet (provided at the back of the frame) and anchoring the cable or chain to the wall or floor. Make the length and location of the cable such that the unit cannot pull on the gas connection while the cable is connected
6. The gas connection must be made with a quick disconnect device compliant with ANSI Z21.41b - latest edition.

WARNING
ELECTRICALLY GROUND THE UNIT AT THE TERMINAL PROVIDED. FAILURE TO GROUND UNIT COULD RESULT IN ELECTROCUTION AND DEATH.

7. For electronic spark ignition, provide 115 VAC, 60 HZ, 1 phase, 5 AMP electrical service through the rear of the electrical console. Local codes and/or The National Electrical Code should be observed in accordance with ANSI/NFPA70, latest edition. AN ELECTRICAL GROUND IS REQUIRED. The electrical schematic is located on the inside of the service panel and this manual. **In Canada**, provide electrical service in accordance with the Canadian Electrical Code, CSA-C22.1 Part 1 and/or local codes.
8. Installation must conform with local codes or with the American National Standard Z223, latest edition, National Fuel Gas Code. The pan should be installed in an adequately ventilated room with a provision for adequate air supply to the unit. The best ventilation will use a vent hood and exhaust fan. DO NOT obstruct the flue or vent duct after installation. **In Canada**, installation must conform to CAN/CGA B149 Installation Codes for Gas Appliances and Equipment and/or local codes
9. Adequate space for proper service and operation is required. DO NOT block any air intake spacings to the combustion chamber or obstruct air flow.
10. After the pan has been connected to the gas supply, check all gas joints for leaks. A soap solution or other suitable leak detector should be used. **Do not use flame to check for leaks**
11. The appliance and its individual shutoff valve must be **protected** from the gas supply piping system during any pressure testing of that system at test pressures **in excess of 1/2 PSI (3.45 kPa)**. The appliance may be **isolated** from the gas supply piping system by closing its individual manual shutoff valve during any pressure testing of the gas supply piping system.

Initial Start-Up

Now that your Braising Pan has been installed, you should test it to ensure that the unit is operating correctly.

1. Remove literature and packing materials from the interior and exterior of the unit.
2. Put enough water into the pan to cover the bottom to a depth of ¼ to ½ inch. With the pan body in the horizontal position, note how the water lies in the pan, to confirm that the pan was leveled properly during installation.
3. Following "To Start Pan" instructions for your pan model, begin heating the water at a thermostat setting of 235°F. At this setting, heating should continue until the water boils.

4. To shut down the unit, turn the thermostat dial to "OFF".

WARNING
WATER IS EXTREMELY HOT AND CAN CAUSE SEVERE BURNS. AVOID CONTACT WITH HOT WATER WHEN EMPTYING UNIT.

5. Turn the tilting handwheel clockwise to pour out the water and to confirm that the pan body can be tilted smoothly from horizontal to vertical.

If the unit functions as described above, it is ready for use. If it does not, contact your local Groen Authorized Service Agency.

Operation

A. Controls

Operator controls for the Braising Pans are:

1. Power ON Switch and Power ON indicator
2. The thermostat dial, located on the control console to the left rear of the pan body. This dial is used to turn the thermostat on or off and to set the thermostat for pan temperatures between 175° and 425° F.
3. HEATING indicator light located on the control console, lights when the burners have ignited.
4. The main supply gas valve, installed on the gas line to the unit.
5. For HFP/2 units with standing pilot flame, the gas control valve is on the Combination Gas Control, which is located under the pan on the gas line to the burner manifold. This valve selects settings of "OFF", "PILOT", or "ON" for the Combination Control. HFP/2 units are also equipped with a mechanical 0-60 minute bell timer.
6. HFP/2E units are equipped with an electrical timer having timing and "Done" indicator lights and a beeper.

B. Operating Procedure

WARNING
KEEP THE APPLIANCE AREA FREE AND CLEAR OF COMBUSTIBLE MATERIALS.

CAUTION
BE SURE ALL OPERATORS READ, UNDERSTAND AND FOLLOW THE OPERATING INSTRUCTIONS, CAUTIONS AND SAFETY INSTRUCTIONS CONTAINED IN THIS MANUAL.

KEEP FLOORS IN BRAISING PAN WORK AREA CLEAN AND DRY. IF SPILLS OCCUR, CLEAN IMMEDIATELY TO AVOID THE DANGER OF SLIPS OR FALLS.

1. ***For Standard Models with Electronic Ignition (HFP/2E)***
 - a. To Start Pan (See Panel Overlay)
 - (1) Set the Power Switch to "OFF."
 - (2) Set the thermostat to "OFF."
 - (3) Open the main supply gas valve (handle parallel to the gas pipe).
 - (4) Set Power Switch to "ON."
 - (5) Rotate the thermostat dial until the Heat Light comes on. (It lights when the main burner is on).

OM-HFP

b. To Turn Off Pan

- (1) Set the thermostat to "OFF".
- (2) Set Power Switch to "OFF."
- (3) For a prolonged shut-off period:
 - (a) Set the thermostat to "OFF".
 - (b) Turn the main gas valve OFF (handle at right angles to the gas pipe).
 - (c) Disconnect the electrical power from the unit.

c. If Power Fails

- 1) Do not try to operate the unit until power is restored.
- 2) When power is restored, follow directions under "To Start Pan."

2. For Models with Optional Standing-Flame Pilot (HFP/2)

a. To Start Pan

- (1) Set thermostat to "OFF".
- (2) Light gas pilot.
 - (a) Set knob on Combination Gas Control Valve to "OFF" by depressing the knob slightly and turning it clockwise.
 - (b) Turn the main supply gas valve ON (parallel to the gas pipe).
 - (c) Tilt the pan, so the pilot burner is easier to reach.
 - (d) Hold a lighted match at the pilot burner, while you depress the knob on the Combination Control and turn it counter-clockwise to the "PILOT" position. Continue to hold the knob down for 60 seconds.
 - (e) Release the knob. The pilot flame should stay lighted.
 - (f) Turn the knob counterclockwise to "ON".
- (3) Turn the thermostat dial to the desired temperature.

CAUTION

DO NOT HEAT AN EMPTY PAN FOR MORE THAN FIVE MINUTES AT A SETTING HIGHER THAN 300°F.

b. To Shut Off Pan

- (1) Set the thermostat dial to "OFF".
- (2) To turn off the gas pilot, depress the knob on the Combination Control and turn it clockwise to "OFF".

c. To Relight Pilot

- (1) Close the main supply gas valve.
- (2) Set the thermostat to "OFF".
- (3) Depress the knob on the Combination Control and turn it clockwise to "OFF".
- (4) Wait 5 minutes, then proceed as instructed at "To Start Pan" above.

WARNING

WHEN TILTING BRAISING PAN FOR PRODUCT TRANSFER:

- 1) USE CONTAINERS DEEP ENOUGH TO CONTAIN AND MINIMIZE PRODUCT SPLASHING.
- 2) PLACE CONTAINER ON A STABLE, FLAT SURFACE, AS CLOSE TO THE BRAISING PAN AS POSSIBLE.
- 3) STAND TO THE SIDE OF THE PAN WHILE POURING — NOT DIRECTLY IN THE POUR PATH OF HOT CONTENTS.
- 4) RETURN PAN BODY TO UPRIGHT POSITION AFTER CONTAINER IS FILLED OR TRANSFER IS COMPLETE.
- 5) DO NOT OVERFILL CONTAINER. AVOID DIRECT SKIN CONTACT WITH HOT CONTAINER AND CONTENTS.

3. To Tilt Pan Body

Turn the tilting handwheel clockwise to tilt the pan body, or counterclockwise to return the pan body to horizontal. 23 complete turns of the hand-wheel will tilt the body 90 degrees to vertical.

4. To Move a Unit on Casters

The unit must be anchored with a cable or chain to avoid accidentally breaking or pulling loose the gas connection. When the unit is to be

moved, first turn off and disconnect the gas connection. Disconnect the cable from its anchor point on the floor or wall. Anchor the unit again as soon as it is in its new operating location or returned to the previous location. Turn on the gas supply and check for leaks with a soap solution. If leaks are found, do not operate the equipment. Call for service.

5. To Preheat the Pan

- a. For best braising or frying results, preheat pan before you put in any food.
- b. To get an even temperature across the pan, preheat at a setting of 300°F or less for 15 minutes or through several on-off cycles of the burner.

CAUTION
DO NOT HEAT AN EMPTY PAN FOR MORE THAN FIVE MINUTES AT A SETTING HIGHER THAN 300°F. DAMAGE TO THE PAN COULD RESULT.

c. Cooking

1. To simmer or slowly heat an item, set the dial at 210°F or lower. Put the cover down to minimize moisture loss, or leave it up to help dry or reduce

the product. Set the thermostat higher to cook or drive off moisture faster. You may adjust the thermostat to any setting to cook the item exactly as required.

2. Leave the cover vent open to let excess steam escape. For long simmering operations, you may wish to close the vent to retain moisture.



WARNING
STEAM CAN CAUSE BURNS. AVOID ESCAPING STEAM WHEN RAISING COVER.

3. To check progress when the cover is closed, lift the handle of the vent cover slightly, and move it quickly to either side.
4. Standing to one side of the pan (to avoid the steam that will be released) grasp the nearer corner of the cover handle and raise the cover. The cover will stay in the open position until you push it down.

WARNING
ITEMS IN SAUCE OR MELTED FAT CAN SLIDE FORWARD SUDDENLY DURING TILTING AND SPLASH THE HOT LIQUID.

5. To pour or dump product, remove grease, or assist cleaning, first raise the cover, then tilt the pan forward by turning the tilting handwheel. When you stop turning the wheel, the pan body will hold its position.

Sequence of Operation

The following "action-reaction" outline is provided to help the user understand how the equipment functions.

A. Standard Models with Spark Ignition

1. When the power switch is turned on, it starts the spark igniter and opens the automatic valve for the pilot burner. The spark ignites a pilot flame, which heats the sensor. The sensor then sends a signal to turn off the spark. The flame thereafter acts as a standing pilot until the power is turned off.
2. If the pilot flame is not sensed within 90 seconds after spark begins, a timer shuts down the entire operation. To attempt a second trial for ignition, turn off the power switch. Check the gas supply valves and wait five minutes before trying again by switching power on. If there is still no pilot flame in four tries, close all valves, turn off the power, and contact an authorized Groen Service Agency.

3. When the operator sets a temperature on the thermostat, it causes the automatic valve to admit gas to the main burner, where it is ignited by the pilot flame. When the braising pan reaches the set temperature, the thermostat switch opens. This stops the signal to the gas control valve and shuts off gas to the main burner. The pilot flame remains lit. When the pan cools below the set temperature, the thermostat switch closes and starts another cycle. On and off cycling continues and maintains the pan at the desired temperature. This action is indicated by the Heat indicator light.

B. Models with Optional Standing Pilot Ignition

OM-HFP

1. When the operator presses down the knob on the Combination Gas Control Valve and turns it to "Pilot", gas is admitted to the pilot burner. Depressing the knob in this position overrides the automatic control, which otherwise shuts off all gas supply when the thermopile is cold. Lighting and maintaining the pilot flame for sixty seconds heats the thermopile to operating temperature, so the thermopile begins to provide electric current at 750 millivolts. Electricity from the thermopile powers the control circuit and the Combination Gas Control Valve. When the thermopile begins operating at full capacity, the knob may be released.
2. When the knob is turned to "ON", the automatic valve for the main burner is able to open. Setting the thermostat to call for heat causes the thermostat to send a signal to the valve, which opens and admits gas to the main burner. Gas from the main burner is ignited by the pilot flame. When the pan reaches the set temperature, the thermostat switch opens, stopping the signal to the main burner valve and causing the valve to close. When the pan cools below the set temperature, the thermostat switch closes and starts another heating cycle. On-off cycling continues and maintains the pan at the desired temperature.

C. All Models

1. The thermostat controls heating by alternately calling for flames at the full capacity of the main burners and then signaling the control to shut the burner off completely. Because the control works in this "all or nothing" way, the pan heats as fast as it can until it reaches the set temperature, not matter what that temperature is. Turning the thermostat dial to a higher temperature will cause heating to continue longer, until the pan reaches the higher temperature, but it cannot make the pan heat any faster.
2. The pans are protected from overheating by a secondary thermostat. If the pan temperature rises above 425° F, the thermostat causes the automatic gas control valve to close. When the pan cools, the thermostat automatically resets and permits normal operation to continue.
3. The tilt switch will shut off all burners whenever the braising pan is tilted.
4. A gas pressure regulator, which controls gas pressure at the burner manifold is built into the gas control valve.
5. Turning the tilting handwheel turns a worm gear, which turns a gear wheel on one of the trunnions which support the pan body. Turning the gear wheel produces the tilting action.

NOTE: Neither model will heat (operate) when the braising pan has been tilted 10 degrees or more from the horizontal.

Cleaning

WARNING

KEEP WATER AND SOLUTIONS OUT OF CONTROLS AND BURNERS. NEVER SPRAY OR HOSE THE CONTROL CONSOLE OR ANY ELECTRICAL CONNECTIONS.

1. Before any cleaning operation, shut off the burner by turning the thermostat dial to "OFF". If water or cleaning solution will be sprayed, unplug the unit from the electric power source, or shut off the power at the circuit breaker or fuse panel.
2. Clean all food-contact surfaces soon after use, before the pan has cooled completely. If the unit is in continuous use, thoroughly clean and sanitize both interior and exterior at least once every 12 hours.



CAUTION
MOST CLEANERS ARE HARMFUL TO THE SKIN, EYES, MUCOUS MEMBRANES AND CLOTHING. PRECAUTIONS SHOULD BE TAKEN TO WEAR RUBBER GLOVES, GOGGLES OR FACE SHIELD AND PROTECTIVE CLOTHING. CAREFULLY READ THE WARNINGS AND FOLLOW THE DIRECTIONS ON THE LABEL OF THE CLEANER TO BE USED.

3. Scrape or rinse out large amounts of food residues, then wash the inside of the pan body with a mixture of hot water and soap or an appropriate detergent, such as Mikro-Quat from ECOLAB. Follow the detergent supplier's recommendations on strength of the solution to use. Rinse the pan thoroughly with hot water and drain completely.



Use a brush, cloth, sponge or other non-abrasive tool for cleaning.



Don't use metal implements or steel wool to clean the braising pan.

4. To remove materials stuck to the equipment, use a brush, sponge, cloth, plastic or rubber scraper, or plastic wool along with the detergent or soap solution. To minimize the effort required in washing, let the detergent solution sit in the pan and soak into the residue, or heat the detergent solution briefly in the pan. Do NOT use any abrasive materials or metal implement that might scratch the surface, because scratches make the pan hard to clean and provide places for bacteria to grow. Do NOT use steel wool, which may leave particles imbedded in the pan surface and cause eventual corrosion and pitting.

5. As part of the daily cleaning program, clean all external and internal surfaces that may have been soiled. Remember to check such parts as the underside of the cover, control console, etc.

6. Controls and the control console may be cleaned with a damp cloth.

7. The exterior surface of the unit may be polished with a recognized stainless steel cleaner, such as "Zepper" from Zep Manufacturing Co.

8. If the equipment needs to be sanitized, use a sanitizing solution equivalent to one that supplies 200 parts per million available chlorine. Obtain advice on the best sanitizing agent from your supplier of sanitizing products. Following the supplier's instructions, apply the sanitizing agent after the unit has been cleaned and drained. Rinse off the sanitizer thoroughly.

NOTICE
NEVER LEAVE A CHLORINE SANITIZER IN CONTACT WITH STAINLESS STEEL SURFACES LONGER THAN 30 MINUTES. LONGER CONTACT CAN CAUSE CORROSION.

9. If there is difficulty removing mineral deposits or a film left by hard water or food residues, clean the pan thoroughly and then use a deliming agent, such as Groen De-limer/De-Scaler (P/N 114800) or Lime-Away from ECOLAB, in accordance with the manufacturer's directions. Rinse and drain the unit before further use.

10. If especially difficult cleaning problems persist, contact your cleaning product representative for assistance.

OM-HFP

Maintenance

Your Braising Pan is designed to require minimum maintenance, but certain parts may need replacement after prolonged use. After installation, no user adjustment should be necessary. If a service need arises, only authorized personnel should perform the work.



cleaning the inside of the control console, and possible adjustment of the pilot light. At least twice a year, grease the two trunnion bearings.

WARNING
ELECTRIC POWER ALWAYS SHOULD BE SHUT OFF BEFORE WORK IS DONE ON INTERNAL COMPONENTS.

WARNING
DISCONNECT ELECTRICAL POWER FROM THE UNIT BEFORE ATTEMPTING TO GREASE THE TRUNNION BEARINGS.

Service personnel should check the unit at least once a year. This periodic maintenance should include inspecting electrical wires and connections,

A Service Log is provided with the warranty information at the back of this manual. Each time service is performed on your Groen equipment, enter the date on which the work was done, what was done, and who did it. Keep the manual with the equipment for quick and easy reference.

Troubleshooting

Your Groen Braising Pan will operate smoothly and efficiently if properly maintained. However, the following is a list of checks to make in the event of a problem. If the actions suggested do not solve the problem, call your qualified Groen Service Representative. For the phone number of the nearest agency, call your area Groen representative or the Groen Parts and Service Department. If an item on the list is followed by **X**, the work should only be performed by a qualified service representative.

WARNING
BEFORE REPLACING ANY PARTS, DISCONNECT THE UNIT FROM THE ELECTRICAL POWER SUPPLY AND CLOSE THE MAIN GAS VALVE. ALLOW FIVE MINUTES FOR GAS TO VENT.
USE OF ANY REPLACEMENT PARTS OTHER THAN THOSE SUPPLIED BY GROEN OR THEIR AUTHORIZED DISTRIBUTORS CAN CAUSE INJURY TO THE OPERATOR AND DAMAGE TO THE EQUIPMENT AND WILL VOID ALL WARRANTIES.

Important: Service performed by other than factory authorized personnel will void all warranties.

| SYMPTOM | WHO | WHAT TO CHECK |
|---|-----------------------|---|
| <small>X indicates items which must be performed by an authorized technician.</small> | | |
| A. All Models | | |
| Pan is hard to tilt. | Auth Service Rep Only | a. Gears for foreign materials, lubrication, and alignment. X b. Broken tilt or worm gears. X |
| Burners will not light | User | a. That the main gas supply valve is open (handle is in line with the gas pipe) b. Gas supply to the building. c. That the pan body is horizontal. |
| | Auth Service Rep Only | d. Thermostat operation. The thermostat should click when the dial is rotated to settings above and below the temperature of the pan. X |
| Pan continues to heat after it reaches desired temperature | User | a. Thermostat dial setting |
| | Auth Service Rep Only | b. Thermostat calibration. X c. Thermostat operation. The thermostat should click when the dial is rotated to settings above and below the temperature of the pan. X |

Important: Service performed by other than factory authorized personnel will void all warranties.

| SYMPTOM | WHO | WHAT TO CHECK X indicates items which must be performed by an authorized technician. |
|--|-----------------------|---|
| Pan stops heating before reaching desired temperature. | User | a. Thermostat dial setting. |
| | Auth Service Rep Only | b. Thermostat calibration. X c. Thermostat operation. The thermostat should click when the dial is rotated to settings above and below the temperature of the pan. X |
| Pan heats unevenly | User | a. That the pan body is horizontal. b. That the pan is preheated properly in accordance with the instructions in the Operation section of this manual. |

B. Standard Models with Electronic Ignition System (Refer to Schematic)

| | | |
|--|-----------------------|--|
| System does not produce a spark | Auth Service Rep Only | a. Thermostat, and close the contacts if they are open X b. AC voltage between terminals on secondary side of transformer. If it is not 24 Volt, replace the transformer X c. That the high tension cable is in good condition. If cracked or brittle, replace. X d. Pilot electric ceramic for crack or break. X e. Pilot spark gap. Regap. X |
| Spark is present but the pilot will not light. | Auth Service Rep Only | a. That the pilot valve is securely connected to terminals. X b. For 24 VAC at terminals PV and PV/MV. If 24V is not present, replace the ignition control module. X b. That gas pressure is at least 3.5" W.C.(8.7818 µb). X c. For gas at the pilot. If it is not flowing: (1) Check the pilot gas line for kinks and obstructions. X (2) Clean orifice, if necessary. X (3) Check magnetic operator for pilot valve on gas valve. Repair or replace as necessary. X d. That the pilot spark gap is located in the pilot gas stream. If not, adjust or replace the pilot burner. X e. For drafts. Shield the pilot burner, if necessary. X |
| Pilot lights, but main burner will not come on and spark does not stay on. | Auth Service Rep Only | a. Check operating thermostat to see that it is closed at temperature setting higher than that of the current pan temperature. X b. For 24 V between terminals MV and PV/MV. If 24V is not present, replace the ignition control module. X c. That gas pressure is at least 3.5" W.C.(8.7818 µb). X d. Electrical connections of the main valve to terminals, to assure that they are securely attached. Check magnetic operator for main valve on gas valve. Repair or replace as necessary. X e. That secondary thermostat switch is closed.X |
| Pilot lights, but main burner will not come on, the spark stays on. | Auth Service Rep Only | a. Check for bad burner ground. If necessary, repair with high temperature wire. X b. Pilot burner ceramic insulator for cracks. X c. That high tension cable is not grounded out. If it is, correct the ground-out condition or the pilot burner. X d. For proper gas pressure. X e. Clean pilot assembly, or replace if necessary. X f. Tighten all mechanical and electrical connections. X g. If the pilot flame is weak, increase pilot orifice size. X h. Replace ignition control module. X |
| Main burner comes on but will not stay on. | Auth Service Rep Only | a. Check burner ground for bad wire or connection. Replace if necessary with high temperature wire. X b. Check for low gas supply pressure. If necessary, replace ignition control module. X |

OM-HFP

Important: Service performed by other than factory authorized personnel will void all warranties.

| SYMPTOM | WHO | WHAT TO CHECK X indicates items which must be performed by an authorized technician. |
|---------|-----|---|
|---------|-----|---|

C. Models with Standing Pilot Ignition System

| | | |
|---|-----------------------|--|
| Pilot will not light. | User | a. Lighting procedure, to ensure that the instructions in the Operation section of this manual are followed |
| | Auth Service Rep Only | b. That the pilot gas supply line is purged of air. X c. Pilot gas adjustment screw, to ensure that it is open. X d. Pilot tubing and orifice for clogging. X |
| Pilot flame goes out when Combination Control knob is released. | Auth Service Rep Only | a. Pilot gas adjustment. X b. Are connections from Powerpile generator to Pilotstat power unit and Powerpile operator clean and secure? X c. Are open and closed circuit output voltages of the generator in the acceptable range shown by the charts in the manual for the W720 Systems Tester? X d. Resistance of the Pilotstat power unit. X e. If an appropriate meter is not available, replace the generator first, then the power unit. X |
| Pan will not heat, and pilot light is out | User | a. Is the Combination Gas Control Valve knob turned ON? b. Check the pilot tubing and orifice for clogging. |
| | Auth Service Rep Only | c. Are connections from Powerpile generator to Pilotstat power unit and Powerpile operator clean and secure?X d. Are Open and closed circuit output voltages of the generator in the acceptable range shown by the charts in the manual for the W720 Systems Tester?X e. If an appropriate meter is not available, replace the generator. X |
| Pan will not heat, but pilot light is burning | Auth Service Rep Only | a. That secondary thermostat switch is closed. |

Parts List - HFP/2E & HFP/2

(Keyed to Drawing on Page 16)

To order parts, contact your authorized Groen Service Agency. Supply the model designation, part description, part number, quantity, and, where applicable, voltage and phase.

| Key | Description | Part No. | Key | Description | Part No. |
|-----|-----------------------------------|----------|-----|-------------------------------------|-----------|
| 1 | Gear Carrier Assembly (Casting) | 014079 | 29 | Vent Cover with Stud | 003265 |
| 2 | Worm Gear Sector | 009829 | 30 | Spacer - Short | 002378 |
| 3 | Thrust Bearing | 002790 | 31 | Knob - Plastic | 002408 |
| 4 | Worm Gear (Single R.H.) | 012026 | 32 | Arm - Vent Cover | 002377 |
| 5 | Handwheel Shaft (15d" long) | 003123 | 33 | Nut - Acorn | 005471 |
| 6 | Handwheel Assembly | 012061 | 34 | Spacer - Long | 012733 |
| 7 | Handwheel Shaft & Worm Assy. | 049868 | 35 | Gas Control Valve - Nat. Stnd. Plt. | 002648 |
| 8 | Bushing - Snap | 000453 | 36 | Gas Control Valve - Prop. Stnd. Plt | 002649 |
| 9 | 90° Alemite Grease Fitting | 012195 | 37 | Pilot Burner (Natural) Stnd. Plt. | 001125 |
| 10 | Hex Head Screw d" -16 x1" long | 005612 | 38 | Pilot Burner (Propane) Stnd. Plt. | 001129 |
| 11 | Washer - Lock d" | 005618 | 39 | Thermopile - Standing Pilot | 001126 |
| 12 | Retaining Ring - external (2") | 012826 | 40 | Timer, Mech, Standing Pilot | 001154 |
| 13 | Alemite Grease Fitting (straight) | 012100 | 41 | Tilt Switch & Clip | 122176 |
| 14 | Nut - Hex d -16 | 003566 | 42 | Thermostat (425°F) | 013481 |
| 15 | Swivel Joint | 076680 | 43 | Thermostat (100°F to 450°F) | 041700 |
| 16 | Trunnion Race (Casting) | 013488 | 45 | Transformer 120/24V | 106233 |
| 17 | Hex Head Screw d" - 16 x 1½" lg. | 005615 | 46a | Pilot Bracket - Electronic Ignition | 119418 |
| 18 | Orifice #54 (Natural Gas) | 045897 | 46b | Pilot Bracket, Standing Pilot | 128518 |
| 19 | Orifice #65 (Propane Gas) | 050047 | 47 | Pilot Burner - Elec. Ignition | 127578 |
| 20 | Gas Valve Manual Shut-Off | 098458 | 50 | Burner Tube | 051619 |
| 21 | Actuator Bracket Assy (size 2) 9" | 074630 | 51 | Gas Valve Natural - Elec. Ignition | 123815 |
| 22 | Actuator Bracket Assy (size 3-4) | 014085 | 52 | Gas Valve Propane - Elec. Ignition | 128412 |
| 23 | Spring (size 2) | 012413 | 53 | Orifice Ignition Tube | See Table |
| 24 | Spring (size 3 & 4) | 012533 | 54 | Ignition Tube Size 2 | 128810 |
| 25 | Spring Rod Assembly | 012524 | | Ignition Tube Size 3 | 128809 |
| 26 | Cover Assembly (size 2) | 014030 | | Ignition Tube Size 4 | 128808 |
| 27 | Cover Assembly (size 3) | 048798 | | | |
| 28 | Cover Assembly (size 4) | 046450 | | | |

OM-HFP

Parts List - HFP/2E & HFP/2

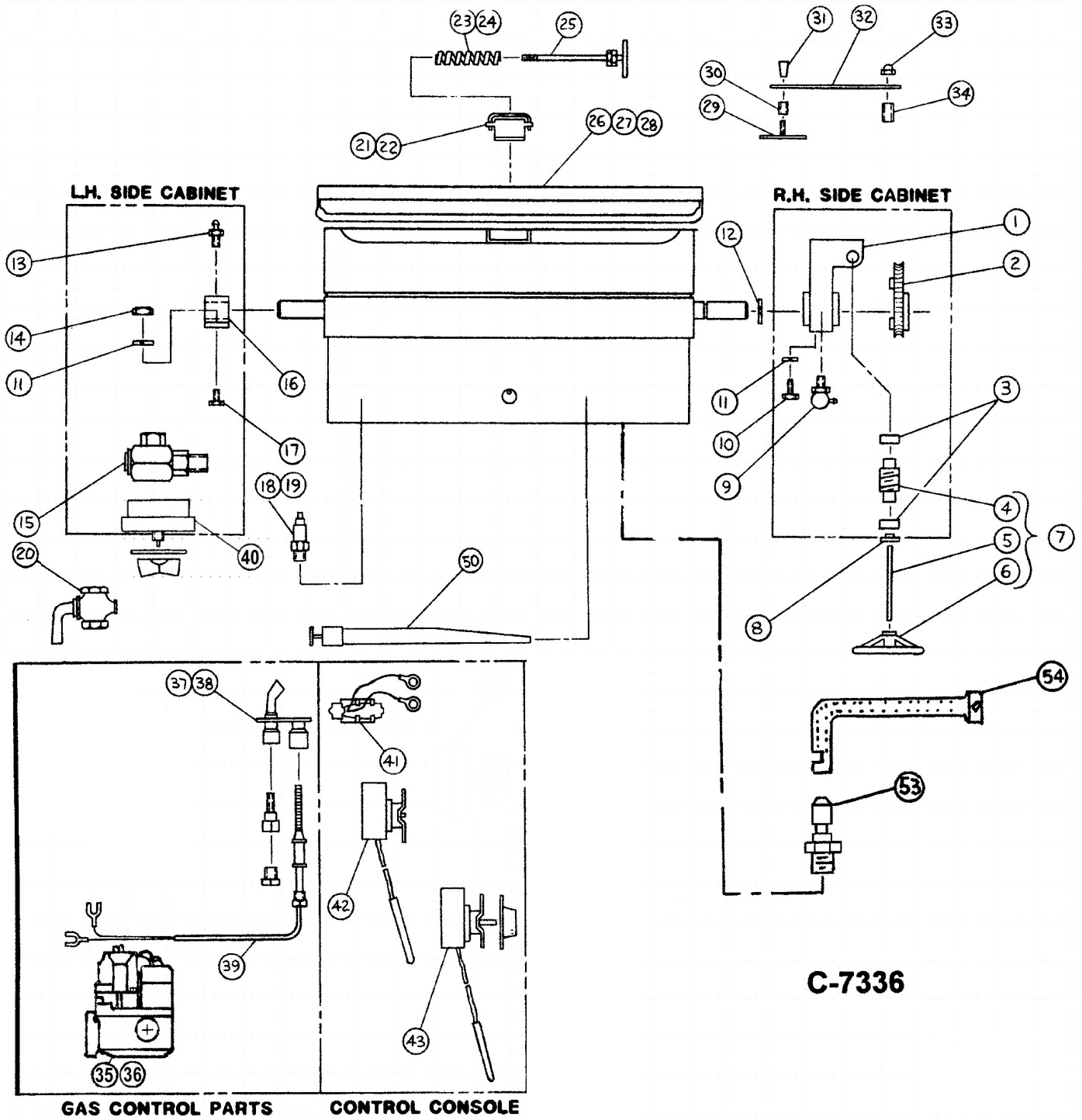

Parts List Pan Sub-Assembly, HFP/2E

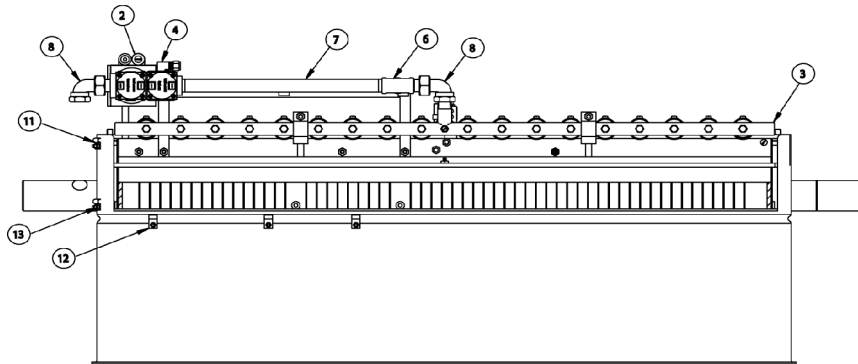
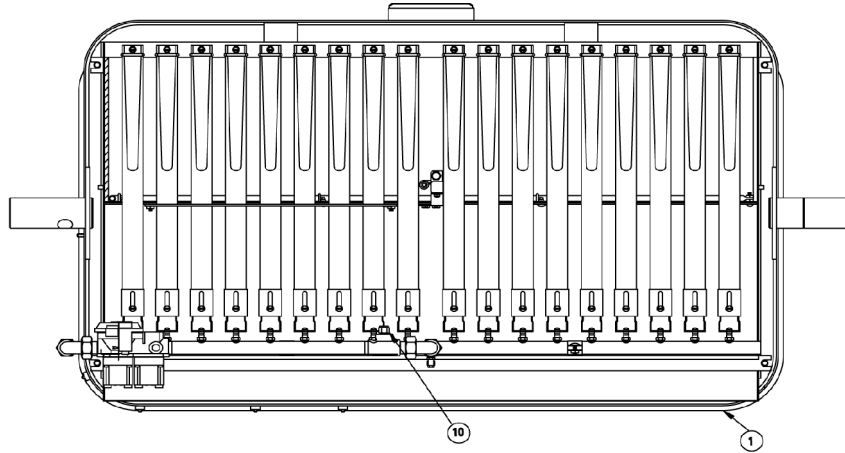

| Key | Description | Part No. | Key | Description | Part No. |
|-----|-----------------------------------|----------|-----|--------------------------------------|----------|
| 1 | Pan Sub-Assembly HFP/2-4 | 127652 | 6 | Tee, 1/2" NPT | 008772 |
| | Pan Sub-Assembly HFP/2-3 | 127582 | 7 | Nipple, 1/2" NPT x 12" Long (Size 4) | 005600 |
| | Pan Sub-Assembly HFP/2-2 | 127763 | | Nipple, 1/2" NPT x 12" Long (Size 2) | 008227 |
| 2 | Valve, Gas | 123815 | 8 | Elbow, 90° Union, 1/2" NPT | 141354 |
| 3 | Assy Comb Chamber-burner HFP/2E-4 | 127666 | 10 | Connector Male, 1/2" NPT x 1/4" tube | 049429 |
| | Assy Comb Chamber-burner HFP/2E-3 | 127665 | 11 | Clamp, Conduit, 3/8" | 008224 |
| | Assy Comb Chamber-burner HFP/2E-2 | 127664 | 12 | Clamp, 1/4" Duplex Tube | 005045 |
| 4 | Elbow 1/8" NPT x 1/4" tube (90°) | 097195 | 13 | Nut, Hex #10 x 32 | 013613 |

OM-HFP

Parts List Combustion Chamber & Burner Assembly, HFP/2E-4

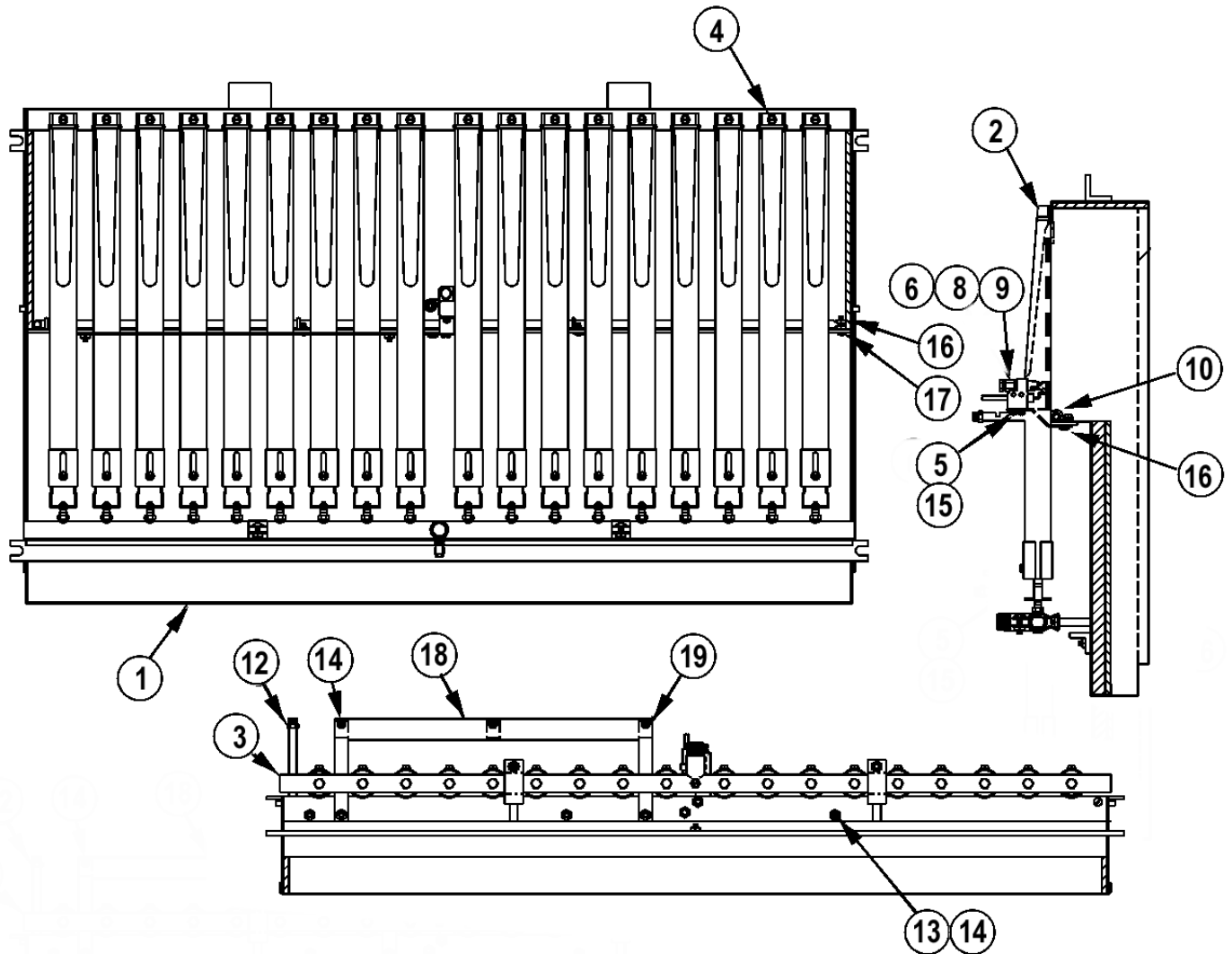

| Key | Description | Part No. | Key | Description | Part No. |
|-----|---------------------------------------|----------|-----|---|----------|
| 1 | Combustion Chamber assy, HFP/2E-4 | 119409 | 12 | Ignition Tube Assy, size 4, (natural gas) | 127621 |
| 2 | Burner Tube | 051619 | 13 | Screw, #10-32 x 1" hex, slotted head cap | 093478 |
| 3 | Manifold Assembly complete HFP/2E-4 | 069709 | 14 | Nut, hex keps #10-32 | 071256 |
| 4 | Sheet metal screw #10, 3/8" long | 074507 | 15 | Lock Washer #10, stainless steel | 005654 |
| 5 | Screw #10-32 x 1/4" fill. hd, slotted | 090797 | 16 | Hex nut with integral washer | 012940 |
| 6 | Bracket, Pilot | 119418 | 17 | Screw, round head 1/4" x 20 x 1" | 012847 |
| 8 | Pilot Orifice Spud, .026" | 119449 | 18 | Bracket, Cable routing | 119468 |
| 9 | Assembly, Pilot Burner | 127578 | 19 | Clamp, Conduit 3/8" | 008224 |
| 10 | Clamp, Igniter Tube | 085107 | | | |

Parts List

Combustion Chamber & Burner Assembly, HFP/2E-3, -2

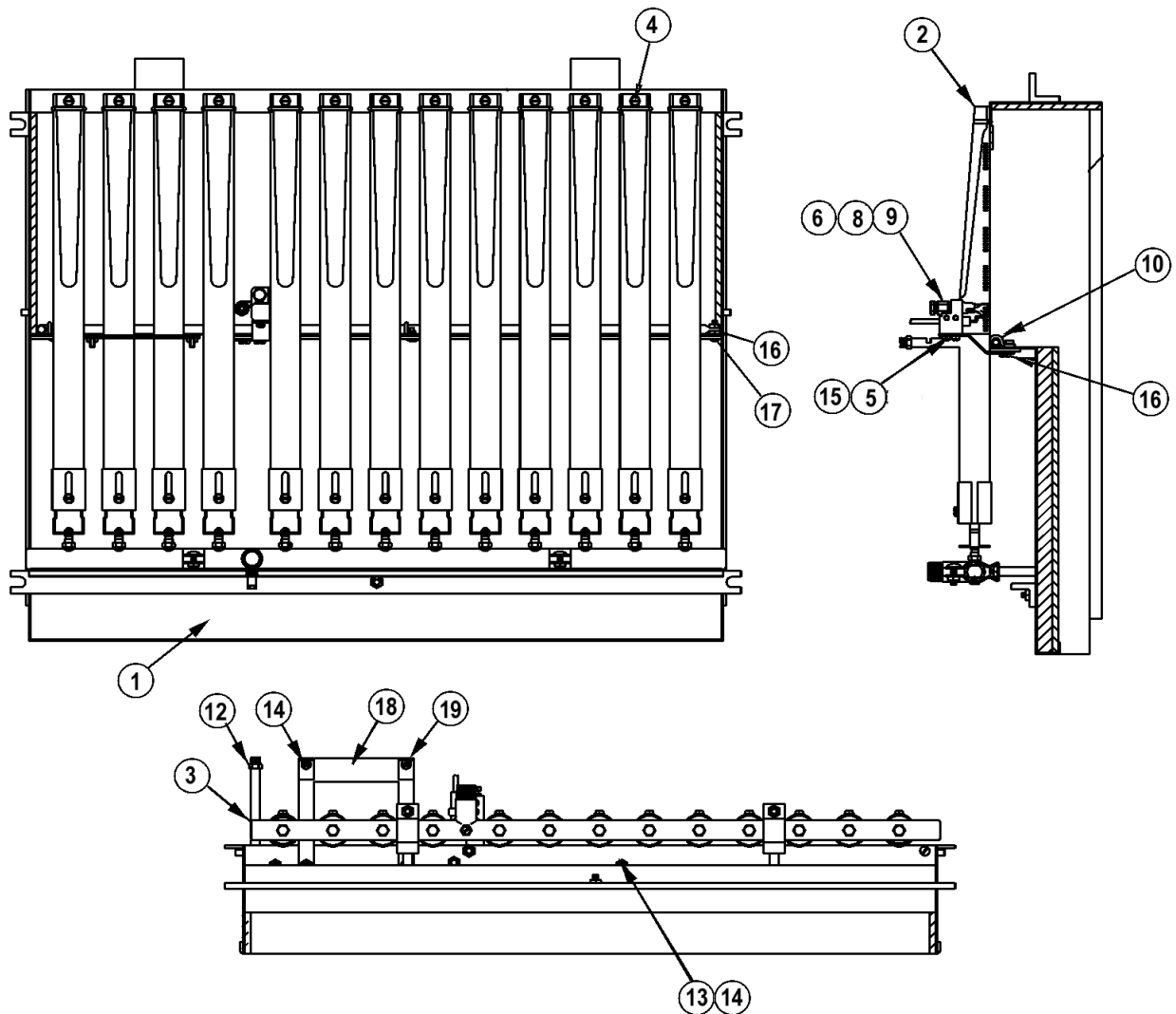

| Key | Description | Part No. | Key | Description | Part No. |
|-----|---------------------------------------|----------|-----|---|----------|
| 1 | Combustion Chamber assy, HFP/2E-3 | 119426 | 12 | Ignition Tube Assy, size 3, (natural gas) | 127620 |
| 2 | Burner Tube | 051619 | 13 | Screw, #10-32 x 1" hex, slotted head cap | 093478 |
| 3 | Manifold Assembly complete HFP/2E-3 | 069255 | 14 | Nut, hex keps #10-32 | 071256 |
| 4 | Sheet metal screw #10, 3/8" long | 074507 | 15 | Lock Washer #10, stainless steel | 005654 |
| 5 | Screw #10-32 x 1/4" fill. hd, slotted | 090797 | 16 | Hex nut with integral washer | 012940 |
| 6 | Bracket, Pilot | 119418 | 17 | Screw, round head 1/4" x 20 x 1" | 012847 |
| 8 | Pilot Orifice Spud, .026" | 119449 | 18 | Bracket, Cable routing, HFP/2-3, -2 | 123726 |
| 9 | Assembly, Pilot Burner | 127578 | 19 | Clamp, Conduit 3/8" | 008224 |
| 10 | Clamp, Igniter Tube | 085107 | | | |

OM-HFP

Parts List Control Console Assembly, HFP/2E (HFP/2E shown; HFP/2 is similar)

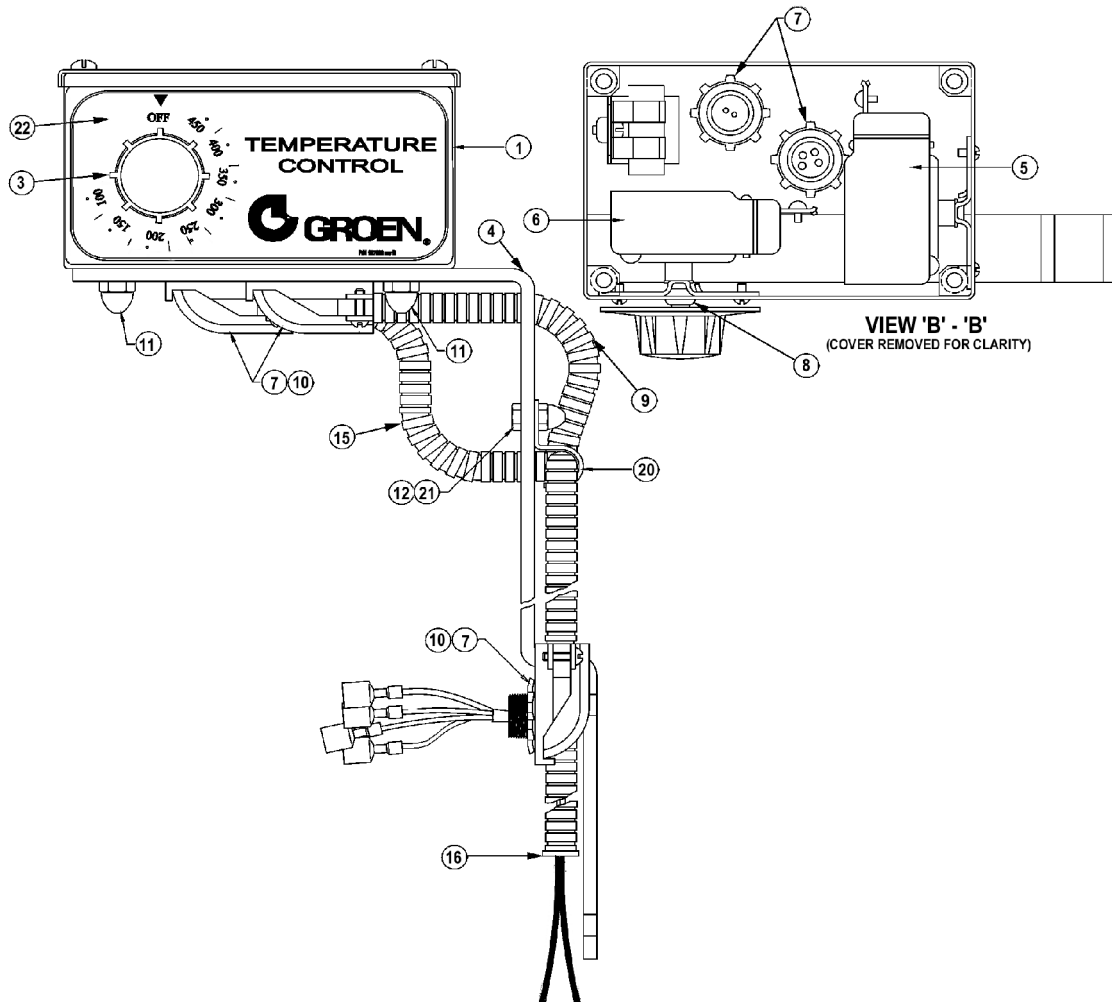

| Key | Description | Part No. | Key | Description | Part No. |
|-----|---------------------------------------|----------|-----|-------------------------------------|----------|
| 1 | Control Console Shell Assembly | 127546 | 12 | Screw, hex head cap #10-32 x 3/8" | 128757 |
| 3 | Knob, thermostat | 128525 | 13 | Screw, rd. hd, machine #6-32 x 3/8" | 009697 |
| 4 | Bracket, Control Console mounting | 122175 | 15 | Conduit, flexible 5/16 | 006940 |
| 5 | Thermostat 425°F | 013481 | 16 | Conduit, insulator | 071934 |
| 6 | Thermostat 100° to 450° with dip seal | 041700 | 18a | Switch, Mercury, Elec. Ignition | 128820 |
| 7 | Conduit Nut, ½" | 005487 | 18b | Switch, Mercury, Standing Pilot | 122176 |
| 8 | Grommet, ¼ ID x ½ OD x 1/16 groove | 001518 | 19 | Mercury Switch Mounting Bracket | 122177 |
| 9a | Harness, wiring, thermostat box | 127695 | 20 | Clamp, conduit, rigid 3/8" | 008224 |
| 9b | Harness, wiring t-stat box Stdg. Plt. | 128650 | 21 | Nut, dome, high profile #10-32 | 128756 |
| 10 | Elbow 90° 3/8" conduit connector #266 | 004098 | 22 | Overlay, Control Console | 127688 |
| 11 | Nut, dome, high profile ¼ - 20 | 090567 | | | |

Parts List Ignition Control Cabinet Assembly, HFP/2E

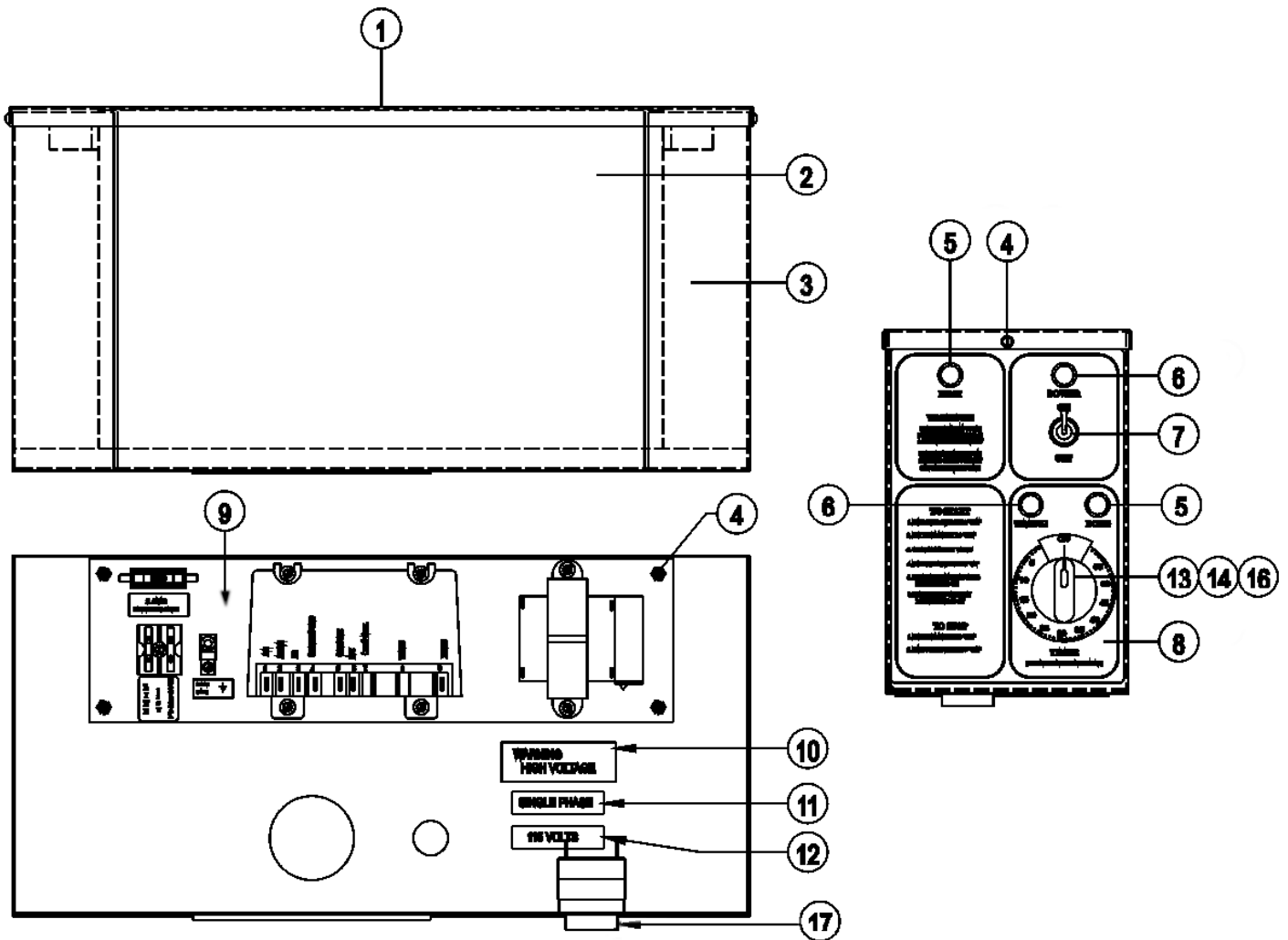

| Key | Description | Part No. | Key | Description | Part No. |
|-----|---------------------------------------|----------|-----|---------------------------------------|----------|
| 1 | Cover, Ignition Control Cabinet | 119441 | | Label, "208 Volts" | 008118D |
| 2 | Side panel, Ignition Control Cabinet | 119440 | | Label, "240 Volts" | 008118G |
| 3 | Weldment, Ignition Control Cabinet | 127508 | 13 | Knob, Timer | 123100 |
| 4 | Screw, pan head 8-32 x 3/8" | 005764 | 14 | Electrical Timer 24 VAC 60 Hz | 096826 |
| 5 | Indicator Light, amber, 24 VAAC | 116384 | 15 | Wiring Diagram (not shown) | 127748 |
| 6 | Indicator Light, red, 24 VAC | 116383 | 16 | Timer Nut | 101145 |
| 7 | On/Off Toggle Switch w/.25" terminals | 006904 | 17 | Beeper | 128355 |
| 8 | Overlay HFP front panel | 123829 | 18 | Harness Wiring Kit (not shown) HFP/2E | 128286 |
| 9 | electrical components assembly | 127510 | | Harness Wiring Gas Valve Sect. HFP/2E | 128287 |
| 10 | Label, Warning "High Voltage" | 072140 | | Grounding Wire HFP/2E Pilot Burner | 128288 |
| 11 | Label, "Single Phase" | 008118K | | Harness, Wiring T-stat Box HFP/2E | 127695 |
| 12 | Label, "115 Volts" | 008118B | | Harness, Wiring, Main HFP/2E | 127743 |

Parts List - Fuel Gas Conversion

(For conversion of a natural gas unit to propane or a propane model to natural gas)

Model: HFP/2E and HFP/2

HFP/2E WITH ELECTRONIC IGNITION

HFP/2 WITH STANDING PILOT

| DESCRIPTION | QTY | NAT GAS | LP GAS | DESCRIPTION | QTY | NAT GAS | LP GAS |
|------------------------------|-----|---------|--------|------------------------------|-----|---------|--------|
| Pilot Orifice | 1 | 119449 | 098647 | Pilot Burner | 1 | 001125 | 001129 |
| Burner Orifice | % | 045897 | 050047 | Burner Orifice | % | 045897 | 050047 |
| Ignition Tube Orifice Size 4 | 1 | 101621 | 112603 | Ignition Tube Orifice Size 4 | 1 | 101621 | 112603 |
| Ignition Tube Orifice Size 3 | 1 | 101622 | 114340 | Ignition Tube Orifice Size 3 | 1 | 101622 | 114340 |
| Ignition Tube Orifice Size 2 | 1 | 056932 | 101625 | Ignition Tube Orifice Size 2 | 1 | 056932 | 101625 |
| Gas Valve | 1 | 123815 | 128412 | Gas Valve | 1 | 002648 | 002649 |
| Serial Plate | 1 | 104961 | 104961 | Serial Plate | 1 | 104961 | 104961 |

*Burner Orifice “Quantity” Chart

| Model | Size 2 | Size 3 | Size 4 |
|-------|--------|--------|--------|
| HFP/2 | 10 | 13 | 18 |

Diagrams and Schematics Electronic Ignition System

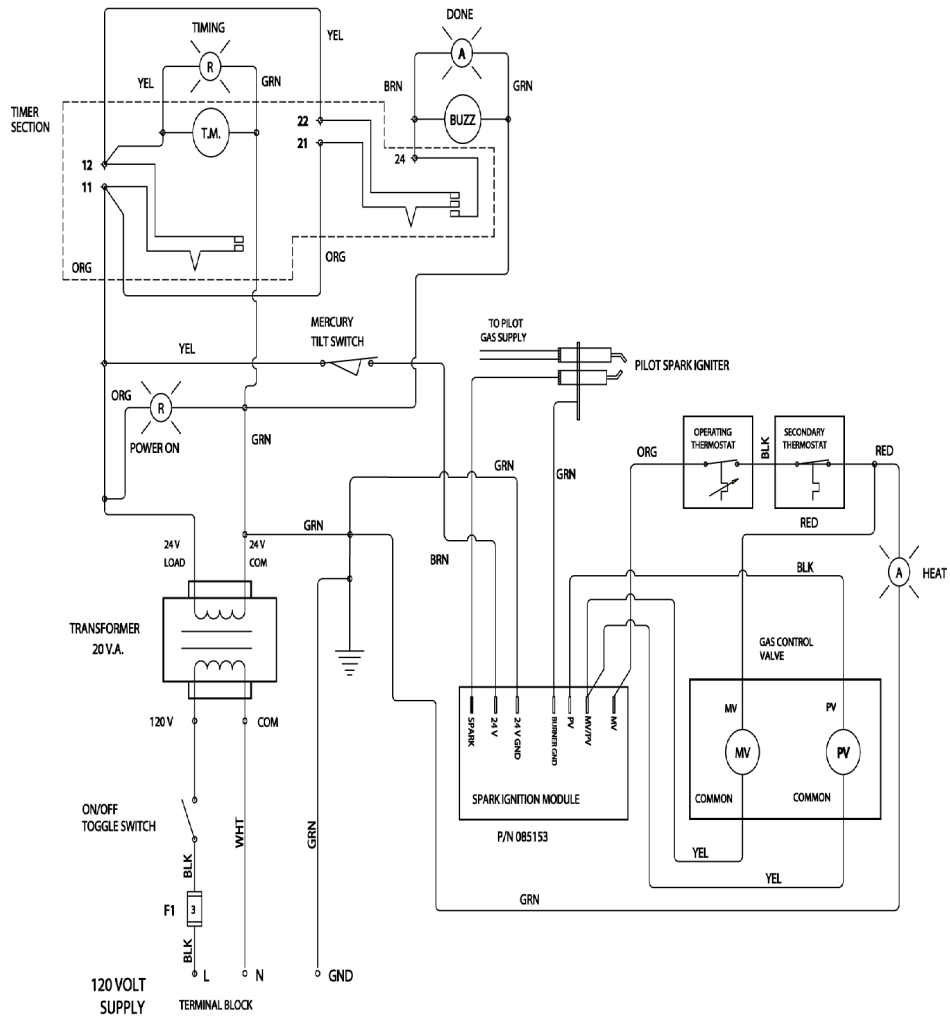

P/N 127747 REV. D

Diagrams and Schematics Standing Pilot Ignition System

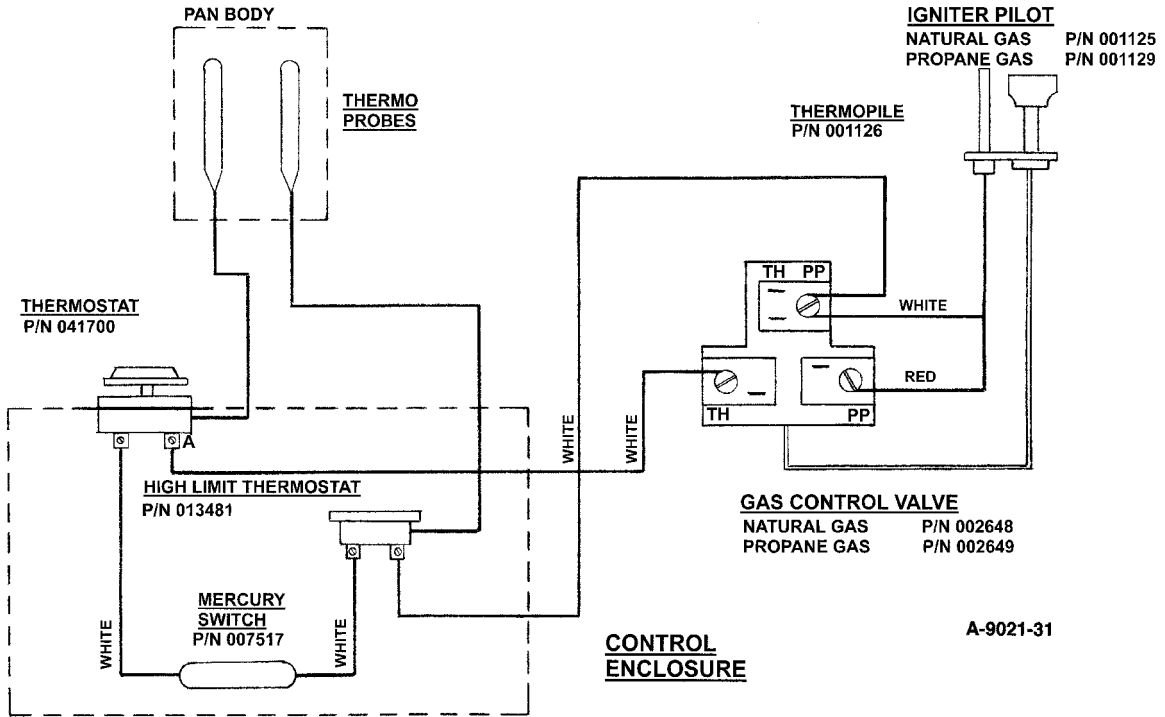

LIMITED WARRANTY TO
COMMERCIAL PURCHASERS*
(U.S. & Canadian Sales Only.)

Groen warrants to original commercial purchaser/users that foodservice equipment manufactured by Groen ("Groen Equipment") (other than CapKold foodservice equipment) shall be free from defects in material and workmanship for (12) twelve months from the date of installation or fifteen (15) months from date of shipment from Groen, whichever date first occurs (the "Warranty Period"), in accordance with the following terms and conditions:

- I. This warranty is limited to replacement parts and related labor for Groen Equipment located at its original place of installation in the United States and Canada.
- II. Damage to Groen Equipment that occurs during shipment must be reported to the carrier, and is not covered under this warranty. The reporting of any damage during shipment is the sole responsibility of the commercial purchaser/user of such Groen Equipment.
- III. For Groen Convection Combo™ Steamer-Ovens, HyPerSteam™ Convection Steamers and HyPlus™ Pressureless Steamers, Groen further warrants to the original commercial purchaser/users of such Groen Equipment that the atmospheric steam generators or boilers contained in such Groen Equipment shall be free from defects in material and workmanship for twenty-four (24) months from the date of installation or twenty-seven (27) months from date of shipment from Groen, whichever date first occurs, provided that: (a) the original purchaser/user shall have also purchased and installed a Groen PureSteam Water Treatment System™ for use in connection with such Groen Convection Combo™ Steamer-Oven, HyPerSteam™ Convection Steamer or HyPlus™ Pressureless Steamer on or before the date such Groen Equipment was installed, (b) the original purchaser/user has continuously used such Water Treatment System in connection with such Groen Equipment from the date of installation, and (c) the commercial purchaser/user shall have maintained such Water Treatment System in accordance with the maintenance and filter cartridge replacement recommendations of Groen, and otherwise maintained such Oven or Steamer in accordance with all other operational and maintenance recommendations of Groen.
- IV. Groen further warrants to the original commercial purchaser/users of Groen Convection Combo™ Steamer-Ovens that the electronic relay and control board contained in such Groen Convection Combo™ Steamer-Oven shall be free from defects in material and workmanship for twenty-four (24) months from the date of installation or twenty-seven (27) months from date of shipment from Groen, whichever date first occurs.
- V. During the Warranty Period, Groen, directly or through its authorized service representative, will either repair or replace, at Groen's sole election, any Groen Equipment determined by Groen to have a defect in material or workmanship. As to any such warranty service during the Warranty Period, Groen will be responsible for related reasonable labor and portal to portal transportation expenses (time & mileage) incurred within the United States and Canada.
- VI. This warranty does not cover boiler maintenance, calibration, periodic adjustments as specified in operating instructions or manuals, consumable parts (such as scraper blades, gaskets, packing, etc.), and labor costs incurred for removal of adjacent equipment or objects to gain access to Groen Equipment. This warranty does not cover defects caused by improper installation, abuse, careless operation, or improper maintenance of Groen Equipment. This warranty does not cover damage to Groen Equipment caused by poor water quality or improper boiler maintenance.

OM-HFP

- VII. THIS WARRANTY IS EXCLUSIVE AND IS IN LIEU OF ALL OTHER WARRANTIES, EXPRESSED OR IMPLIED, INCLUDING ANY IMPLIED WARRANTY OF MERCHANTABILITY OR FITNESS FOR A PARTICULAR PURPOSE, EACH OF WHICH IS HEREBY EXPRESSLY DISCLAIMED. THE REMEDIES DESCRIBED ABOVE ARE EXCLUSIVE AND IN NO EVENT SHALL GROEN BE LIABLE FOR SPECIAL, CONSEQUENTIAL, OR INCIDENTAL DAMAGES FOR THE BREACH OR DELAY IN PERFORMANCE OF THIS WARRANTY.
- VIII. Groen Equipment is for commercial use only. If sold as a component of another (O.E.M.) manufacturer's equipment, or if used as a consumer product, such Equipment is sold AS IS and without any warranty.

* (Covers all Groen Equipment (other than CapKold foodservice equipment) ordered after September 11, 2001).

GROEN[®]

1055 Mendell Davis Drive • Jackson MS 39272
888-994-7636 • 601-372-3903 • Fax 888-864-7636
groen.com