

# OPERATOR & SERVICE MANUAL

IMPORTANT INFORMATION, KEEP FOR OPERATOR

This manual provides information for:

## MODEL TDB/6 STEAM JACKETED KETTLE

### Domestic

- Self Contained
- Table Top Mounted
- Electrically Heated
- Tilting



**THIS MANUAL MUST BE RETAINED FOR FUTURE REFERENCE. READ, UNDERSTAND AND FOLLOW THE INSTRUCTIONS AND WARNINGS CONTAINED IN THIS MANUAL.**

#### FOR YOUR SAFETY

Do not store or use gasoline or other flammable vapors and liquids in the vicinity of this or any other appliance.

#### WARNING

Improper installation, adjustment, alteration, service or maintenance can cause property damage, injury or death. Read the installation, operating and maintenance instructions thoroughly before installing or servicing this equipment.

#### NOTIFY CARRIER OF DAMAGE AT ONCE

It is the responsibility of the consignee to inspect the container upon receipt of same and to determine the possibility of any damage, including concealed damage. Groen suggests that if you are suspicious of damage to make a notation on the delivery receipt. It will be the responsibility of the consignee to file a claim with the carrier. We recommend that you do so at once.

Manufacture Service/Questions 888-994-7636.

Information contained in this document is known to be current and accurate at the time of printing/creation. Reference our product line website for the most updated product information and specifications.  
© 2023 Electrolux Professional, Inc. All Rights Reserved.

PART NUMBER 148732, REV. G (09/23)

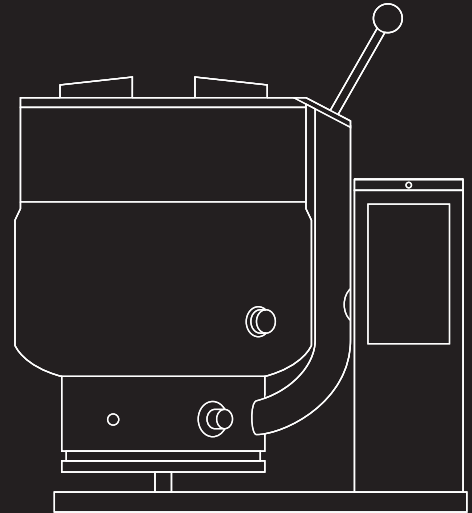

888-994-7636, fax 888-864-7636  
unifiedbrands.net

Part of  Electrolux  
Professional  
Group

# IMPORTANT - READ FIRST - IMPORTANT

- CAUTION:** BE SURE ALL OPERATORS READ, UNDERSTAND AND FOLLOW THE OPERATING INSTRUCTIONS, CAUTIONS, AND SAFETY INSTRUCTIONS CONTAINED IN THIS MANUAL.
- WARNING:** THIS UNIT IS INTENDED FOR USE IN THE COMMERCIAL HEATING, COOKING AND HOLDING OF WATER AND FOOD PRODUCTS, PER THE INSTRUCTIONS CONTAINED IN THIS MANUAL. ANY OTHER USE COULD RESULT IN SERIOUS PERSONAL INJURY OR DAMAGE TO THE EQUIPMENT AND WILL VOID WARRANTY.
- WARNING:** KETTLE MUST BE INSTALLED BY PERSONNEL QUALIFIED TO WORK WITH ELECTRICITY. IMPROPER INSTALLATION CAN RESULT IN INJURY TO PERSONNEL AND/OR DAMAGE TO EQUIPMENT.
- DANGER:** ELECTRICALLY GROUND THE UNIT AT THE TERMINAL PROVIDED. FAILURE TO GROUND UNIT COULD RESULT IN ELECTROCUTION AND DEATH.
- WARNING:** AVOID ALL DIRECT CONTACT WITH HOT EQUIPMENT SURFACES. DIRECT SKIN CONTACT COULD RESULT IN SEVERE BURNS.
- WARNING:** AVOID ALL DIRECT CONTACT WITH HOT FOOD OR WATER IN THE KETTLE. DIRECT CONTACT COULD RESULT IN SEVERE BURNS.
- CAUTION:** DO NOT OVER FILL THE KETTLE WHEN COOKING, HOLDING OR CLEANING. KEEP LIQUIDS A MINIMUM OF 2-3" (5-8 CM) BELOW THE KETTLE BODY RIM TO ALLOW CLEARANCE FOR STIRRING, BOILING AND SAFE PRODUCT TRANSFER.
- WARNING:** TAKE SPECIAL CARE TO AVOID CONTACT WITH HOT KETTLE BODY OR HOT PRODUCT WHEN ADDING INGREDIENTS, STIRRING OR TRANSFERRING PRODUCT TO ANOTHER CONTAINER.
- WARNING:** WHEN TILTING KETTLE FOR PRODUCT TRANSFER:
- 1) WEAR PROTECTIVE OVEN MITT AND PROTECTIVE APRON.
  - 2) USE CONTAINER DEEP ENOUGH TO CONTAIN AND MINIMIZE PRODUCT SPLASHING.
  - 3) PLACE CONTAINER ON STABLE, FLAT SURFACE, AS CLOSE TO KETTLE AS POSSIBLE.
  - 4) STAND TO LEFT OR RIGHT SIDE OF KETTLE (DEPENDING ON TILTING HANDLE PLACEMENT) WHILE POURING . DO NOT STAND DIRECTLY IN POUR PATH OF HOT CONTENTS.
  - 5) POUR SLOWLY, MAINTAIN CONTROL OF KETTLE BODY HANDLE AT ALL TIMES, AND RETURN KETTLE BODY TO UPRIGHT POSITION AFTER CONTAINER IS FILLED OR TRANSFER IS COMPLETE.
  - 6) DO NOT OVER FILL CONTAINER. AVOID DIRECT SKIN CONTACT WITH HOT CONTAINER AND ITS CONTENTS.
- CAUTION:** KEEP FLOORS IN FRONT OF KETTLE WORK AREA CLEAN AND DRY. IF SPILLS OCCUR, CLEAN IMMEDIATELY, TO AVOID SLIPS OR FALLS.
- WARNING:** FAILURE TO CHECK PRESSURE RELIEF VALVE OPERATION PERIODICALLY COULD RESULT IN PERSONAL INJURY AND/OR DAMAGE TO EQUIPMENT.
- WARNING:** WHEN TESTING, AVOID ANY EXPOSURE TO THE STEAM BLOWING OUT OF THE PRESSURE RELIEF VALVE. DIRECT CONTACT COULD RESULT IN SEVERE BURNS.
- WARNING:** TO AVOID INJURY, READ AND FOLLOW ALL PRECAUTIONS STATED ON THE LABEL OF THE WATER TREATMENT COMPOUND.
- WARNING:** BEFORE REPLACING ANY PARTS, DISCONNECT THE UNIT FROM THE ELECTRIC POWER SUPPLY.
- WARNING:** KEEP WATER AND SOLUTIONS OUT OF CONTROLS AND ELECTRICAL EQUIPMENT. NEVER USE A HIGH PRESSURE HOSE TO CLEAN

# IMPORTANT - READ FIRST - IMPORTANT

## KETTLE SURFACES.

- CAUTION:** MOST CLEANERS ARE HARMFUL TO THE SKIN, EYES, MUCOUS MEMBRANES AND CLOTHING. PRECAUTIONS SHOULD BE TAKEN. WEAR RUBBER GLOVES, GOGGLES OR FACE SHIELD AND PROTECTIVE CLOTHING. CAREFULLY READ THE WARNINGS AND FOLLOW THE DIRECTIONS ON THE LABEL OF THE CLEANER TO BE USED.
- CAUTION:** USE OF ANY REPLACEMENT PARTS OTHER THAN THOSE SUPPLIED BY GROEN OR THEIR AUTHORIZED DISTRIBUTORS CAN CAUSE OPERATOR INJURY AND DAMAGE TO THE EQUIPMENT, AND WILL VOID ALL WARRANTIES.
- IMPORTANT:** SERVICE PERFORMED BY OTHER THAN FACTORY AUTHORIZED PERSONNEL WILL VOID WARRANTIES.
- WARNING:** DO NOT HEAT AN EMPTY KETTLE. EXCESSIVE STEAM PRESSURE COULD DEVELOP.

# References

KLENZADE SALES CENTER ECOLAB. Inc.  
370 Wabasha  
St. Paul, Minnesota 55102  
800/352-5326 or 612/293-2233

NATIONAL FIRE PROTECTION ASSOCIATION  
60 Battery March Park  
Quincy, Massachusetts 02269

NFPA/70 - The National Electrical Code

NSF INTERNATIONAL  
789 N. Dixboro Road  
P.O. Box 130140  
Ann Arbor, Michigan 48113-0140

UNDERWRITERS LABORATORIES, INC.  
333 Pfingsten Road  
Northbrook, Illinois 60062

ZEP MANUFACTURING CO.  
1310-T Seaboard Industrial Blvd.  
Atlanta, Georgia 30318

# Equipment Description



The TDB and TDBC are table top, tilting, steam jacketed kettles with a thermostatically controlled, self-contained, electrically-heated steam supply and appropriate controls, mounted on a sturdy base. (Image at left shown with optional TS/9 stand).

The body of the kettle is constructed of stainless steel, welded into one solid piece. The kettle is furnished with a reinforced rim and a butterfly shaped pouring lip. It has a steam jacket rated for a design pressure of 50 PSI (3.45 Bar/345 kPa). Kettle finish is 180 emery grit on the inside and bright semi-deluxe on the outside. A tilt handle allows the operator to manually tilt the kettle body in a controlled manner. Pouring height accepts pans up to four inches high on a table top.

A built-in steam generator, sized for the kettle capacity and heated by electricity, delivers steam into the jacket. "Airless" operation of the steam jacket permits uniform, efficient heating at temperatures as low as 150°F (65.6°C) and as high as 295°F (146°C). In addition to the adjustable thermostat for operating control, the unit has a tilt cut-off switch, low water cut-off, pressure relief valve, and high-limit pressure switch as safety features. A heating indicator light, pressure gauge, and sight glass are provided for monitoring kettle operation.

A single electrical connection is required for installation. The unit employs single phase 208 or 240 volt power.

KETTLE CHARACTERISTICS	
Description	TDB/6
Kettle Capacity	10 qt / 9.4 liter
Jacket Capacity	1 quart / 0.9 liter
Inside Diameter	12 in / 30.5 cm
Depth	9 in / 23 cm
kW at 208 Volts Single Phase	3.6 KW, 17.3 Amperes
kW at 240 Volts Single Phase	4.8 KW, 20 Amperes
Base Width	19 in / 48.3 cm
Base Depth	9.25 in / 23.5 cm

Optional equipment available:

1. Lift-off cover
2. Basket insert
3. TS/9 Stand, which holds a pan for filling (see image at left)
4. Faucets

# Inspection & Unpacking

**CAUTION**  
SHIPPING STRAPS ARE UNDER TENSION AND CAN SNAP BACK WHEN CUT. TAKE CARE TO AVOID PERSONAL INJURY OR DAMAGE TO THE UNIT BY STAPLES LEFT IN THE WALLS OF THE CARTON.

**CAUTION**  
THIS UNIT WEIGHS 50 LBS (23 KG). INSTALLER SHOULD OBTAIN HELP AS NEEDED TO LIFT THIS WEIGHT SAFELY.

The unit will arrive in a crate and will be bolted or banded to a skid. Immediately upon receipt, inspect the crate carefully for exterior damage.

Carefully remove the crate from around the kettle. Thoroughly inspect the unit for concealed damage. Report any shipping damage or incorrect shipments to the delivery agent.

Write down the model number, serial number, and installation date, and retain this information for future reference. Space for these entries is provided at the top of the Service Log at the back of this manual. Keep this manual on file and available for operators to use.

When installation is to begin, carefully cut any straps which hold the unit on the skid. Lift the unit straight up off the skid. Examine packing materials to be sure loose parts are not discarded with the materials.

Attach the tilt handle (normally shipped inside the kettle) by carefully threading it into the socket on the trunnion support. Be careful to avoid cross-threading the fine threads on the trunnion.

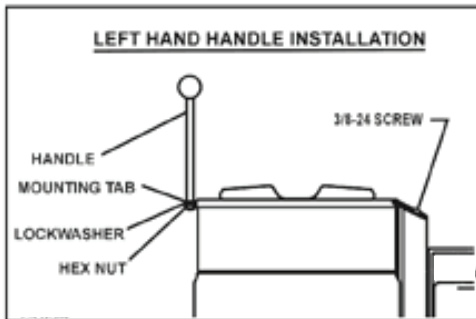

**NOTE:** After handle installation on the right hand side, retain the hardware supplied with the unit for left hand installation.

# Installation

**WARNING**  
INSTALLATION OF THE KETTLE MUST BE DONE BY A CERTIFIED ELECTRICIAN OR AUTHORIZED REPRESENTATIVE QUALIFIED TO WORK WITH ELECTRICITY. IMPROPER INSTALLATION CAN RESULT IN INJURY TO PERSONNEL AN/OR DAMAGE TO EQUIPMENT.

**CAUTION**  
BEFORE ANY ELECTRICAL CONVERSION, VERIFY THAT THE BRANCH CIRCUIT WIRING IS ADEQUATE TO HANDLE ANY INCREASE AMPERAGE REQUIREMENTS. REFER TO THE ELECTRICAL SPECIFICATIONS LISTED BELOW.



The TDB/6 Kettle is provided with complete internal wiring and is ready for immediate connection. A wiring diagram is provided in this manual and on the inside of the control housing service panel.

The completed unit has been operated at the factory to test all controls and heater elements.

1. Set the kettle in place and level it. The base should be securely fastened to a table or work surface. Installation under a ventilation hood is recommended.
2. Once the unit is anchored to a mounting surface, apply a small bead of silicone caulk around the perimeter of the kettle base and seal the joint.
3. Provide electrical power as specified on the electrical information plate attached to the equipment. Observe local codes and/or The National Electrical Code in accordance with ANSI/NFPA 70 - (current edition).
4. Bringing the electrical service through the entrance at the rear of the support housing, making a watertight connection with the incoming lines. (A BX connection is not recommended.)
5. Confirm that the jacket water level is at or just above mid point of sight glass. If the level is low, follow the instructions under "Jacket Filling and Water Treatment" in the "Maintenance" section of the manual.
6. Ensure that the open end of the elbow on the outlet of the pressure relief valve is directed downward. If it is not, turn the elbow to the correct position.
7. Any mechanical or electrical change must be approved by the Groen Engineering Department.

# Initial Start-Up

**IMPORTANT**  
**BE SURE ALL OPERATORS READ, UNDERSTAND AND FOLLOW THE OPERATING INSTRUCTIONS, CAUTIONS AND SAFETY INSTRUCTIONS CONTAINED IN THIS MANUAL.**

**WARNING**  
**AVOID ALL DIRECT CONTACT WITH HOT SURFACES. DIRECT SKIN CONTACT COULD RESULT IN SEVERE BURNS.**

**AVOID ALL DIRECT CONTACT WITH HOT FOOD OR WATER IN THE KETTLE. DIRECT CONTACT COULD RESULT IN SEVERE BURNS.**



A simple turn of the thermostat controls the kettle.

Now that the kettle has been installed, you should test it to ensure that the unit is operating correctly.

1. Remove all literature and packing materials from inside and outside of the unit.
2. Turn on the electrical service to the unit.
3. Pour 1-2 quarts of water into the kettle.
4. Following “To Start Kettle” instructions in the “Operation” section of this manual, begin heating the water at the highest thermostat setting. The heating indicator light should come on immediately, and heating should continue until the water boils.
5. To shut down the unit, turn the thermostat dial to “OFF”.

If the unit functions as described above, it is ready for use. If the unit does not function as intended, first recheck power supply connections and, if necessary, contact your local Certified Service Agency.

# Operation

## WARNING

AVOID ALL DIRECT CONTACT WITH HOT SURFACES. DIRECT SKIN CONTACT COULD RESULT IN SEVERE BURNS.

AVOID ALL DIRECT CONTACT WITH HOT FOOD OR WATER IN THE KETTLE. DIRECT CONTACT COULD RESULT IN SEVERE BURNS.

TAKE SPECIAL CARE TO AVOID CONTACT WITH HOT KETTLE BODY OR HOT PRODUCT, WHEN ADDING INGREDIENTS, STIRRING OR TRANSFERRING PRODUCT TO ANOTHER CONTAINER.

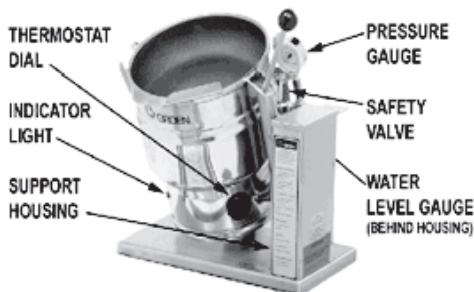

The operator controls kettle heating with the thermostat dial. The dial turns heating element power on or off and sets the kettle operating temperature.

### A. To Start Kettle

1. EVERY DAY make sure that the jacket water level is above the mid-point of the round sight glass. If the level is too low, see “Jacket Filling” and “Water Treatment” on page 14 & 15 of this manual.
2. Check the pressure gauge. If the gauge does not show 20 to 30 inches of vacuum (that is, a reading of 20 to 30 below 0), see “Jacket Vacuum” on page 14 of this manual.
3. Turn on the electrical power to the unit.
4. Turn the thermostat dial to the desired setting. The kettle will then heat to that set point temperature.

### B. To Transfer Product or Empty Kettle

The kettle is designed and manufactured to be tilted in a controlled manner. Grasp the insulated plastic ball firmly. Maintain a firm grip on handle when tilting, while keeping kettle body in a tilted position and when SLOWLY returning the kettle body to an upright position. DO NOT release kettle handle when kettle is partly tilted. It will impact in either the upright or fully tilted position and may cause burns.

### C. To Shut Down Kettle

1. Turn the thermostat dial to “OFF”.
2. For prolonged shut-down, or before cleaning the outside of the unit, shut off the power supply to the unit.

### C. Common Accessories

1. Lift-Off Cover  
As with stock pot cooking, an optional lift off cover can speed up the heating of water and food products. A cover helps retain heat in the cooking vessel and reduces the amount of heat and humidity released into the kitchen. Use of a cover can reduce some product cook times and help maintain the temperature, color and texture of products being held or simmered for extended periods.

Make sure the plastic ball handle is secure on the lift off cover before using. ALWAYS use the plastic handle to place or remove cover from the kettle.

Wear protective oven mitts and a protective apron.

When putting the cover on the kettle, position it on top of kettle rim, with its flat edge facing the pouring lip.

# Operation

## WARNING WHEN TILTING KETTLE

- 1) WEAR PROTECTIVE OVEN MITT AND PROTECTIVE APRON.
- 2) USE DEEP CONTAINER TO CONTAIN AND MINIMIZE PRODUCT SPLASHING.
- 3) PLACE CONTAINER ON STABLE, FLAT SURFACE, AS CLOSE TO KETTLE AS POSSIBLE.
- 4) STAND TO RIGHT OF KETTLE WHILE POURING—NOT DIRECTLY IN POUR PATH OF HOT CONTENTS.
- 5) POUR SLOWLY, MAINTAINING CONTROL OF KETTLE, AND RETURN KETTLE BODY TO UPRIGHT POSITION AFTER CONTAINER IS FILLED OR TRANSFER IS COMPLETE.
- 6) DO NOT OVERFILL CONTAINER. AVOID SKIN CONTACT WITH HOT CONTAINER AND ITS CONTENTS.

## CAUTION

DO NOT TILT KETTLE BODY WITH COVER IN PLACE. COVER MAY SLIDE OFF, CAUSING INJURY TO OPERATOR.

## CAUTION

DO NOT OVERFILL THE KETTLE WHEN COOKING, HOLDING OR CLEANING. KEEP LIQUIDS AT LEAST 2-3" (5-8 cm) BELOW THE KETTLE BODY RIM TO ALLOW CLEARANCE FOR STIRRING, BOILING PRODUCT AND SAFE TRANSFER.

## CAUTION

KEEP FLOORS IN FRONT OF THE KETTLE WORK AREA CLEAN AND DRY. IF SPILLS OCCUR, CLEAN AT ONCE TO AVOID SLIPS OR FALLS.



When removing cover:

- a. Firmly grasp plastic handle
- b. Lift rear edge (farthest from operator) 1- 2" (3-5 cm) to allow any steam and water vapor to escape the cooking vessel. Wait 2-3 seconds.
- c. Tilt cover to 45-60° angle and allow any hot condensate or product to roll off cover back into kettle.
- d. Remove cover, ensuring that any remaining hot condensate or product does not drip on operator, floor or work surfaces.
- e. Place cover on safe, flat, sanitary, out-of-the-way surface, or return to kettle rim. Cover may also be placed in the optional holder for the cover as shown in the photograph.

## 2. Basket Insert

An optional kettle basket insert can assist in cooking water-boiled products including eggs, potatoes, vegetables, shell fish, pasta and rice. The nylon mesh liner must be used when cooking product smaller than the mesh size of the basket, which is approximately 1/4" (6 mm). This includes rice and small pasta shapes. Tips for use:

- a. Allow for the water displacement of the basket and product to be cooked. This may mean only filling the kettle half full of water. Test the basket and product displacement with the kettle OFF, and with cold water in the kettle.
- b. Load baskets on a level, stable work surface.
- c. Lift loaded baskets with both hands. Get help from another person if the basket is too heavy for safe handling.
- d. Slowly lower product into kettle.
- e. When removing baskets with cooked product, lift straight up, ensuring basket bottoms clear the kettle rim and pouring lip. Wear protective oven mitts and protective apron.
- f. Allow hot water to fully drain from product before moving basket away from the kettle. Do not rest baskets on kettle rim or pouring lip. If baskets are too heavy for individual to lift and safely move, get help. Remove product immediately from basket into another container, being sure to avoid contact with hot product and hot basket or...
- g. Place baskets with food on a stable, flat surface, inside a solid steamer or bake pan, to catch any remaining hot water draining from product.

# Sequence of Operation

The following “action-reaction” outline is provided to help understand how the kettle works.

When the operator starts up the kettle by turning the operating thermostat dial from “OFF” to a desired setting, the thermostat switch closes. This lights up the heating indicator light and causes the contactors to close, allowing power to flow to the heating elements. When the temperature of the steam jacket reaches the value corresponding to the dial setting, the thermostat switch opens. This turns off the heating indicator light and causes the contactors to open, stopping the power to the heaters. As soon as the thermostat senses that the kettle is cooling below the set point, the thermostat switch closes, the heating indicator light comes on, the contactors close, and the heaters come on again. On-off cycling continues, keeping the kettle at the set temperature. This is why the heating indicator light cycles on and off during normal operation. Every time the kettle is tilted, the tilt cut-off switch interrupts the power supply to the heaters, so that the heating elements will not operate while not submerged in the jacket water.

If steam pressure greater than 50 PSI (3.45 Bar/345 kPa) is generated in the jacket, the pressure relief valve will open and relieve the excess pressure.

In the event that the jacket water level gets too low and the heating elements overheat, the high limit control will open and shut off power to the elements until the kettle cools. Setting the operating thermostat dial to “OFF” shuts down all control and heating circuits.

# Cleaning

**WARNING**  
KEEP WATER AND SOLUTIONS OUT OF CONTROLS AND ELECTRICAL EQUIPMENT. DO NOT USE A HIGH PRESSURE HOSE TO CLEAN THE CONTROL CONSOLE, ELECTRICAL CONNECTIONS, ETC.

**CAUTION**  
NEVER LEAVE A CHLORINE SANITIZER IN CONTACT WITH STAINLESS STEEL SURFACES FOR LONGER THAN 30 MINUTES. LONGER CONTACT CAN CAUSE CORROSION.

**WARNING**  
AVOID DIRECT CONTACT WITH HOT SURFACES. DIRECT SKIN CONTACT COULD RESULT IN SEVERE BURNS.



Use a brush, sponge, cloth, plastic or rubber scraper, or plastic wool to clean.

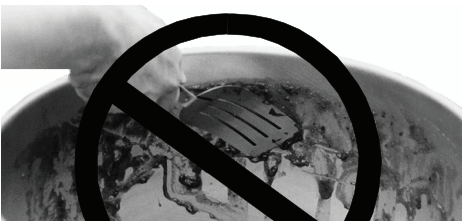

Don't use metal implements or steel wool when cleaning.

1. **Suggested Cleaning Supplies:**
  - a. Cleaner, such as Klenzade HC-10 or HC-32 from ECOLAB, Inc.
  - b. Kettle brushes in good condition.
  - c. Sanitizer such as Klenzade XY-12.
  - d. Film remover such as Klenzade LC-30.
  - e. Stainless steel cleaner such as "Zepper" from "Zep Manufacturing Co.
2. **Precautions**

Before any cleaning operation, shut off the kettle by turning the thermostat dial to "OFF", and shut off all electric power to the unit at a remote switch, such as the circuit breaker.
3. **Procedure**
  - a. Clean food contact surfaces as soon as possible after use, preferably while the kettle is still warm. If the unit is in continuous use, clean and sanitize inside and outside at least once every 12 hours.
  - b. Scrape and flush out large amounts of food residues. Be careful not to scratch the kettle with metal implements.
  - c. Prepare a solution of the detergent/cleaning compound as instructed by the supplier. Clean the unit thoroughly. A cloth moistened with cleaning solution can be used to clean controls, housing, electrical conduit, etc.
  - d. Rinse the kettle thoroughly with hot water. Then drain completely.
  - e. As part of the daily cleaning program, clean all inside and outside surfaces that may have been soiled. Remember to check such parts as the underside of the cover, control housing, etc.
  - f. To remove burned-on foods, use a brush, sponge, cloth, plastic or rubber scraper, or plastic wool along with the cleaning solution. To reduce effort required in washing, let the detergent solution sit in the kettle for a few minutes and soak into the residue. Do NOT use abrasive materials or metal tools that might scratch the surface. Scratches make the surface harder to clean and provide places for bacteria to grow. Do not use steel wool, which will leave particles in the surface and cause eventual corrosion and pitting.
  - g. The outside of the unit may be cleaned with a warm water (100°F (38°C) or less) spray. Do not use a high pressure spray.

# Cleaning

## CAUTION

**MOST CLEANERS ARE HARMFUL TO THE SKIN, EYES, MUCOUS MEMBRANES AND CLOTHING. PRECAUTIONS SHOULD BE TAKEN TO WEAR RUBBER GLOVES, GOGGLES OR FACE SHIELD AND PROTECTIVE CLOTHING. CAREFULLY READ THE WARNINGS AND FOLLOW LABEL DIRECTIONS.**

- h. The outside of the unit may be polished with a recognized stainless steel cleaner like Zepper from Zep Manufacturing Company.
- i. When the equipment needs to be sanitized, use a sanitizing solution equivalent to one that supplies 200 parts per million chlorine. Obtain advice on the best sanitizing agent from your supplier of sanitizing products. Following the supplier instructions, apply the sanitizing agent after the unit has been cleaned and drained. Rinse off the sanitizer thoroughly.
- j. It is recommended that the unit be sanitized just before use.
- k. Clean the kettle thoroughly. If there is difficulty removing mineral deposits or a film left by hard water or food residues, then use a de-liming agent, following manufacturer directions.
- l. Rinse and drain the unit thoroughly before further use.
- m. If especially difficult cleaning problems persist, contact your cleaning product supplier for assistance. The supplier has a trained technical staff with laboratory facilities to serve you.

# Maintenance

**WARNING**  
AVOID ANY EXPOSURE TO THE STEAM  
BLOWING OUT OF THE PRESSURE  
RELIEF VALVE. SEVERE BURNS CAN  
RESULT ON EXPOSED SKIN.  
FAILURE TO CHECK PRESSURE RELIEF  
VALVE OPERATION PERIODICALLY  
COULD RESULT IN PERSONAL INJURY  
AND/OR DAMAGE TO EQUIPMENT.

**CAUTION**  
KEEP GREASE AWAY FROM ELECTRICAL  
PARTS LOCATED NEAR THE GEARS.

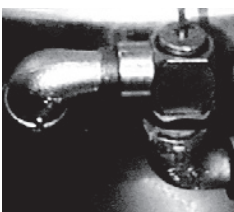

Make sure that the open end of the elbow on the pressure relief valve is directed downward.



The pressure gauge should show a vacuum of 20 to 30 inches when the kettle is cold.

**NOTICE:** Contact an authorized representative when repairs are required.

A Maintenance & Service Log is provided at the back of this manual. Each time maintenance is performed on your kettle, enter the date on which the work was done, what was done, and who did it. Keep this manual on file and available for operators to use. Periodic inspection will minimize equipment down time and increase the efficiency of operation. The following points should be checked:

1. **Jacket Vacuum/Removing Air from Jacket (by Operator)**

Every day, while the kettle is cold, read the pressure/ vacuum gauge. A positive reading or a negative reading between zero and 20" vacuum on the pressure/ vacuum gauge indicates excess air in the jacket. Air in the jacket slows kettle heating and can prevent the kettle from reaching operating temperature. To remove air:

To remove air:

- Start the unit. (See "Operation" section).
- Make sure the elbow on the outlet of the pressure relief valve is turned so that escaping steam is directed down toward the floor. Be sure and follow the instructions on the attached pressure relief valve tag.
- When the pressure/vacuum gauge reaches a positive pressure reading of 5 PSI (0.35 Bar/ 34.5 kPa), release trapped air by lifting the pressure relief valve ring for about one second. Repeat this step, then let the valve ring snap closed, so the valve will seat properly and not leak.

2. **Pressure Relief Valve (by Operator)**

At least twice a month, test the pressure relief valve. Test the valve with the kettle operating at 15 PSI (1.1 Bar/105 kPa), by holding the test ring for at least five seconds. Then release the ring and permit the valve to snap shut. If the ring does not activate, if there is no discharge, or if the valve leaks, stop using the kettle immediately and contact a authorized service representative.

3. **Grease / Lubrication (by Service)**

At least twice a year, grease the two trunnion bearings. The bearings are located within the kettle support housing. Remove the access panels from the support housing with a screwdriver to gain access to the grease fittings. Use a lithium-based, multi-purpose grease. When the access panels are removed, the mounting bolts for the trunnion bearings and tilt switch can also be checked for tightness. When finished, reassemble access panels to support housing.

4. **Jacket Filling**

Every day, before you turn on the unit, make sure the water level is approximately in the center of the water gauge glass. The jacket was filled at the factory with the proper amount of treated water, and is airtight, but over time steam may be vented and water lost.

From time to time, you may need to restore the water to its proper level. The procedure for adding water follows.

# Maintenance

**WARNING**  
TO AVOID INJURY, READ AND FOLLOW  
ALL PRECAUTIONS STATED ON THE  
LABEL OF THE WATER TREATMENT  
COMPOUND.

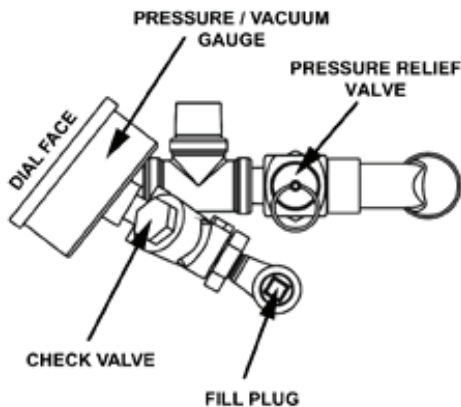

The pressure relief valve and fill plug are located directly behind the pressure/vacuum gauge.

- a. If you are replacing water lost as steam, use distilled water. Do not use tap water. If you are replacing treated water that was drained from the jacket, prepare more treated water as directed below.
- b. Allow the kettle to cool completely. Remove the pipe plug from the jacket fill assembly. Pour in the distilled or treated water. Using a funnel will help you in this process. Hold the pressure relief valve open while you pour, to let air escape from the jacket. Continue adding water until the water level rises to the center of the round sight glass.
- c. Air that gets into the jacket during the filling operation must be removed, because it will make heating less efficient. Follow the procedure in Jacket Vacuum/Removing Air From Jacket above, to restore a negative pressure reading.

## 5. Water Treatment

- a. Place one quart of water in the mixing container. Distilled water is recommended.
- b. Hang a strip of pH test paper on the rim of the container, with about 1 inch of the strip below the surface of the water.
- c. Stir the water continuously, while you slowly add water treatment compound until a color between indicating a pH of 10.5 and 11.5 is reached. (Shown on the pH test kit chart.) Judge the pH by frequently comparing the test strip with the color chart provided in the pH test kit. If there is a problem distinguishing color, use a pH meter.
- d. Use a measuring cup to add the compound so that you may record the exact amount used.
- e. The amount may be used again, if the same water sources and compound are used in the future. However, it is best to check the pH each time treated water is prepared.

# Troubleshooting

Your kettle is designed to operate smoothly and efficiently if properly maintained. However, the following is a list of checks to make in the event of a problem. Wiring diagrams are furnished inside the service panel. X indicates items which must be performed by an authorized technician. **USE OF ANY REPLACEMENT PARTS OTHER THAN THOSE SUPPLIED BY THE MANUFACTURER OR AN AUTHORIZED DISTRIBUTOR CAN CAUSE INJURY TO THE OPERATOR AND DAMAGE TO THE EQUIPMENT AND WILL VOID ALL WARRANTIES.**

SYMPTOM	WHO	WHAT TO CHECK
Kettle will not heat, and heating indicator will not come on.	User	a. Electric power supply to the unit. (Check the circuit breaker.) b. Water level in jacket.
	Authorized Service Rep Only	c. Control circuit fuses. Replace a blown fuse only with a fuse of the same AMP rating. X d. For loose or broken wires. X e. Tilt cut-off switch. X f. That pressure switch is open. X g. Operation of variable thermostat. X h. Low water cutoff. X
Kettle will not heat, but heating indicator comes on.	Authorized Service Rep Only	a. Thermostat calibration. X b. Heater elements with ohmmeter for ground short or open element. If element is defective, call service. X
Kettle continues heating after it reaches the desired temperature.	User	a. Thermostat dial setting.
	Authorized Service Rep Only	b. Thermostat circuit for short. X c. Thermostat operation. The thermostat should click when the dial is rotated above and below the setting for the temperature of the kettle. X d. Contactor, to determine whether it is energized or stuck. X
Kettle stops heating before it reaches the desired temperature.	User	a. Thermostat dial setting.
	Authorized Service Rep Only	b. Thermostat calibration. X c. Thermostat operation. The thermostat should click when the dial is rotated above and below the setting for the temperature of the kettle. X
Kettle heats slowly.	User	a. For air in the jacket. See "Jacket Vacuum" in the "Maintenance" section of this manual.
	Authorized Service Rep Only	b. Heater elements with ohmmeter for ground short or open element. If an element is defective, call service. X c. Voltage of main power source. X
Pressure Relief Valve pops.	User	a. For air in the jacket. See "Jacket Vacuum" in the "Maintenance" section of this manual.
	Authorized Service Rep Only	b. Pressure switch setting. X c. Thermostat operation. Thermostat should click when the dial is rotated above and below the setting for the temperature of the kettle. X d. Pressure relief valve. If the valve pops at pressures below 49 PSI, replace it. e. Contactor, to determine whether it is energized. X

# Parts List

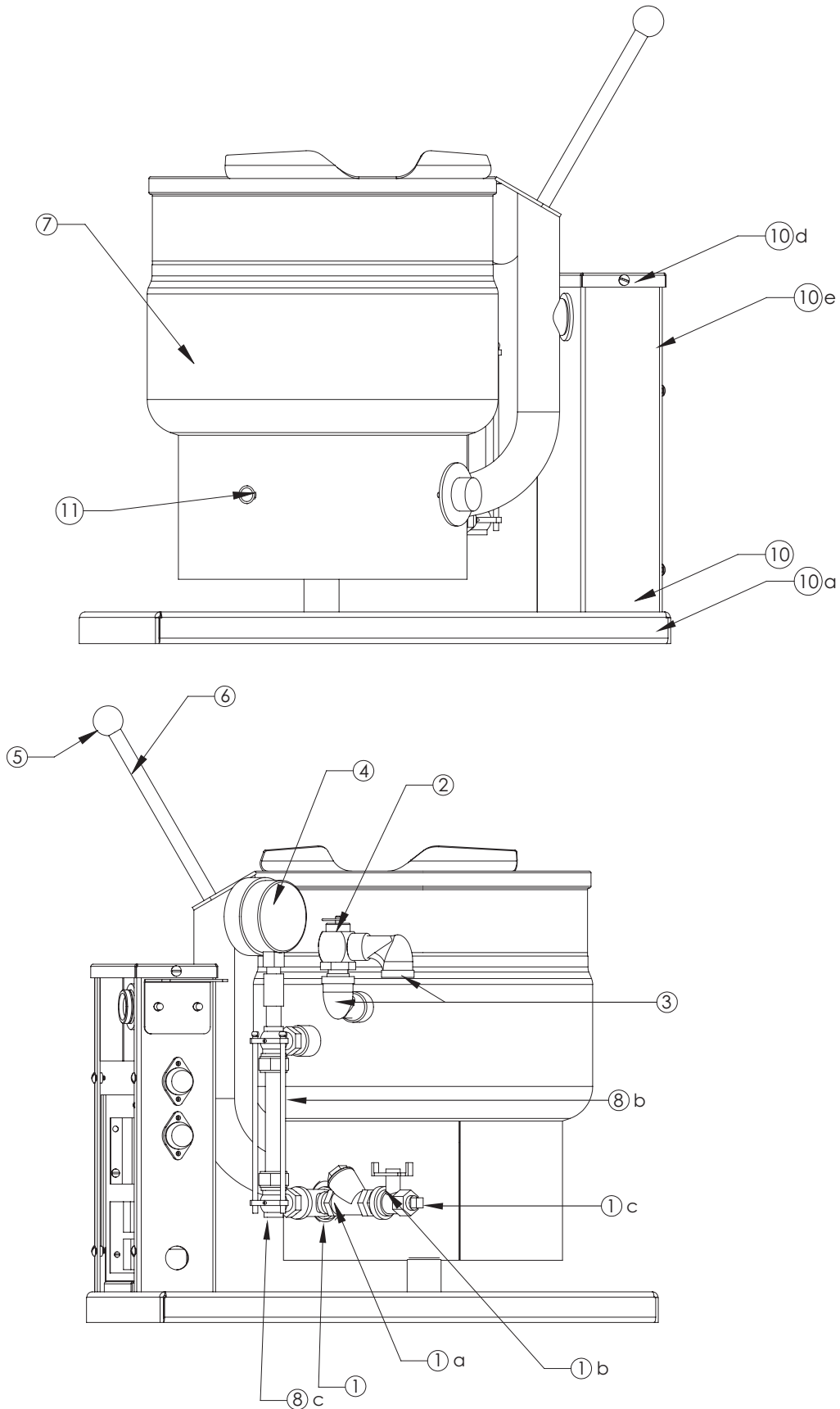

# Parts List

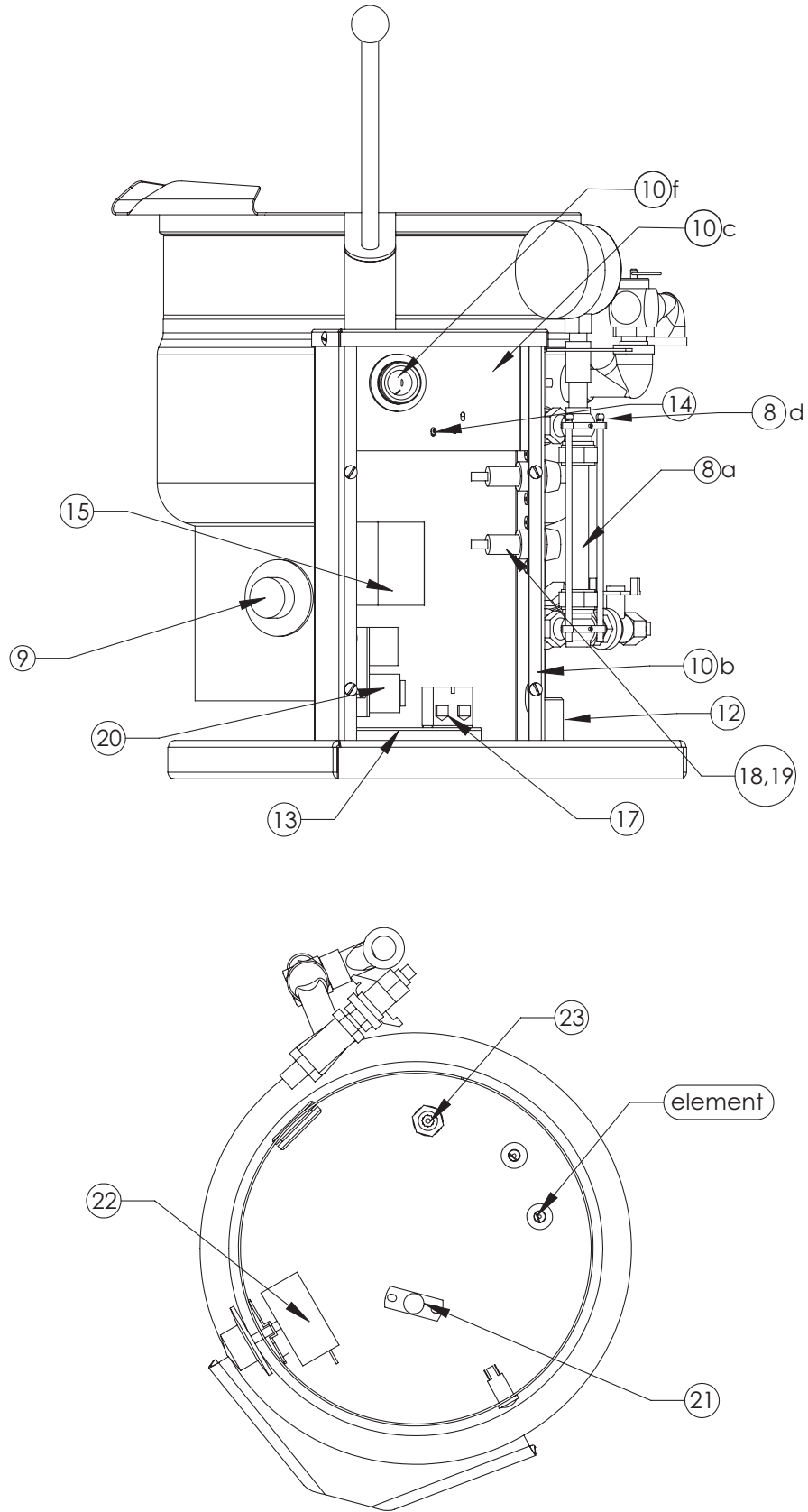

# Parts List

Key	Description	Part No.	Qty
1	ASSEMBLY, WATER FILL (COMPLETE)	096914	1
1a	VALVE, CHECK	096915	1
1b	VALVE, BALL	096916	1
1c	PLUG, PIPE, 1/4 NPT	008270	1
-	NIPPLE, CLOSE, 1/4 NPT, SS	010885	1
-	NIPPLE, CLOSE, 1/4 NPT, SS	005683	1
2	VALVE SAFETY, 50 PSI, 1/2 NPT	097005	1
3	ELBOW, STREET, 90 DEG, 1/2 NPT, CHROME PLATED	010108	2
-	ASSEMBLY, CAUTION PLATE & CHAIN	008332	1
4	GAUGE, COMPOUND, PRESSURE W/DUAL SCALE	084208	1
5	KNOB, BALL, RED	012691	1
6	SHAFT, HANDLE	013597	1
7	ASSEMBLY, KETTLE BODY	<a href="#">MS2978</a>	1
8a	GLASS, WATER LEVEL	008742	1
8b	ROD, GUARD, GLASS	002981	2
8c	FITTINGS, WATER LEVEL GLASS	002845	1
8d	NUT, HEX, CAP, 10-24	005470	2
-	LABEL, MIN-MAX	000558	1
9	KNOB, THERMOSTAT	002868	1
10	ASSEMBLY, PEDESTAL & BASE	131883	1
10a	WELDMENT, BASE BRACKET	124889	1
10b	WELDMENT, PEDESTAL	131884	1
10c	WELDMENT, BRACKET, TRUNNION SUPPORT	131885	1
10d	COVER, TOP, PEDESTAL	<a href="#">131886</a>	1
10e	COVER, SIDE, PEDESTAL	131981	1
10f	BUSHING, BRONZE, 1.25" ID	131898	2
11	LIGHT, INDICATOR, RED, 250V	016028	1
12	BUMPER	003248	1
13	BRACKET, COMPONENT, ELECTRICAL	096937	1
14	SWITCH, TILT	002982	1
15	CONTACTOR, 30 AMP, 2-POLE	009178	1
15a	SCREW, ROUND HEAD, SELF-TAP, 8-32 X 3/8" LONG	005724	2
16	LUG, GROUND, #14-#6 AWG	002863	1
17	TERMINAL BLOCK, 2-POLE	003887	1
17a	SCREW, ROUND HEAD, 8-32 X 1-1/4" LONG	005056	1
18	FUSEHOLDER, 15A, 300V	002944	2
-	SCREW, ROUND HEAD, MACHINE, 6-32 X 5/8" LONG	056745	4
19	FUSE, 3A, 300v	002945	2
20	BOARD, WATER LEVEL	096925	1
-	SCREW, ROUND HEAD, MACHINE, 4-40 X 3/4" LONG	003122	3
21	THERMOSTAT, HI-LIMIT	004588	1
22	THERMOSTAT, CONTROL	012313	1
23	PROBE, WATER LEVEL	096959	1
-	COVER, ELEMENT HOUSING	002915	1
-	GASKET, COVER	007937	3 FT
-	OVERLAY, FRONT	<a href="#">135735</a>	1
-	HARNES	<a href="#">148534</a>	1
-	DIAGRAM, WIRING	148543	1
-	BRACKET, FAUCET	131931	1

# Wiring Diagram

ALL WIRES 18 AWG UNLESS NOTED

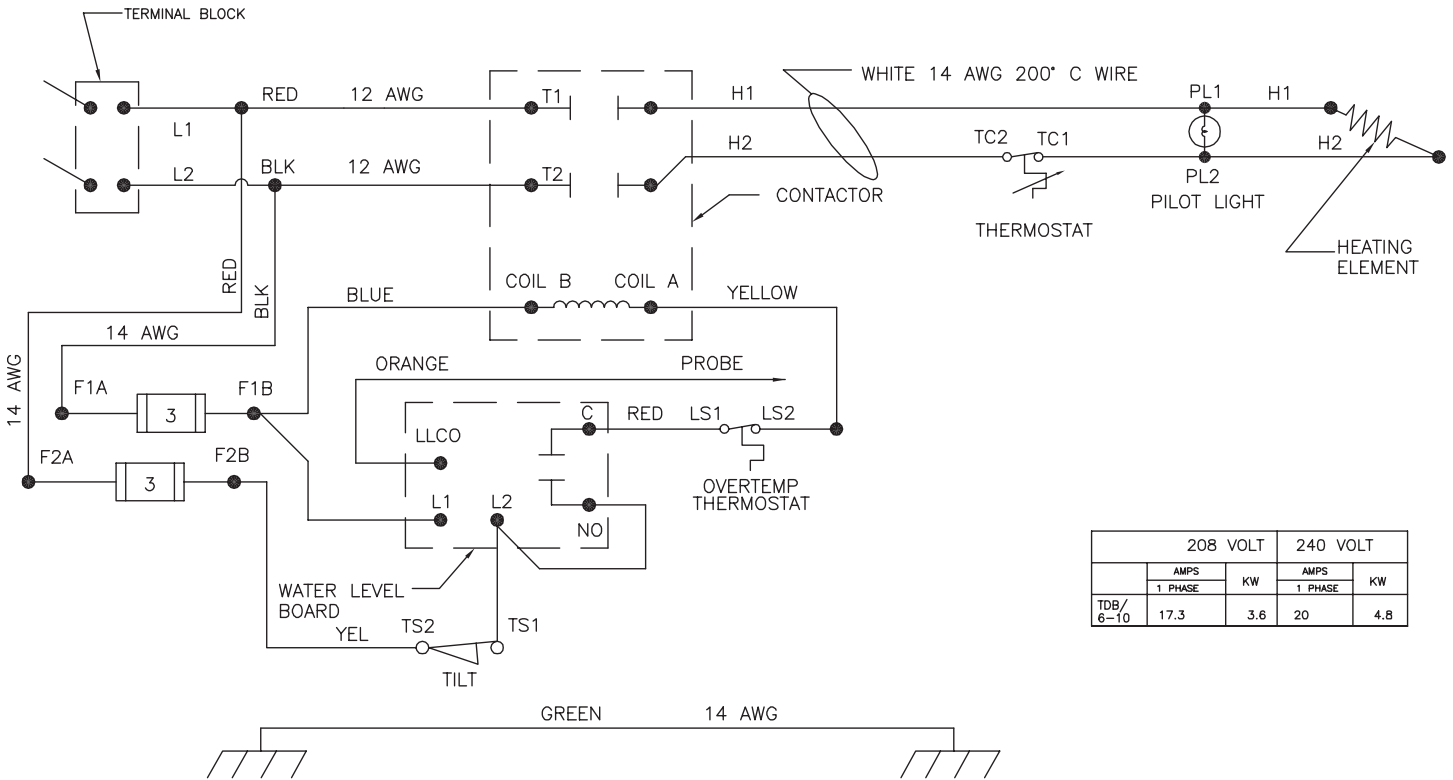

	208 VOLT		240 VOLT	
	AMPS 1 PHASE	KW	AMPS 1 PHASE	KW
TDB/ 6-10	17.3	3.6	20	4.8

P/N 148543 REV B

