

## Installation, Operation and Maintenance Manual

Please read and save these instructions for future reference. Read carefully before attempting to assemble, install, operate or maintain the product described. Protect yourself and others by observing all safety information. Failure to comply with these instructions will result in voiding of the product warranty and may result in personal injury and/or property damage.



### General Safety Information

Only qualified personnel should install this system. Personnel should have a clear understanding of these instructions and all applicable local and national building and fire codes. Personnel should be aware of general safety precautions. SMACNA guidelines should be followed for hanging and supporting the hood. If more information is needed, contact a licensed professional engineer before moving forward.

#### **DANGER**

Always disconnect power before working on or near a unit. Lock and tag the disconnect switch or breaker to prevent accidental power up.

#### **NOTE**

Follow all local electrical, plumbing and safety codes, as well as the National Electrical Code (NEC) and the latest edition of the National Fire Protection Agency Standard for Ventilation Control and Fire Protection of Commercial Cooking Operations, (NFPA 96). Follow the Canadian Electrical Code (CEC) and ULC-S650 if installing this product in Canada.

### Receiving

Upon receiving the product, check to ensure all items are accounted for by referencing the delivery receipt or packing list. Inspect each crate or carton for shipping damage before accepting delivery. Alert the carrier of any damage detected. The customer will make a notation of damage (or shortage of items) on the delivery receipt and all copies of the bill of lading which is countersigned by the delivering carrier. If damaged, immediately contact your Greenheck Representative. Any physical damage to the unit after acceptance is not the responsibility of Greenheck Fan Corporation.

### Unpacking

Verify that all required parts and the correct quantity of each item have been received. If any items are missing, report shortages to your local representative to arrange for obtaining missing parts. Sometimes it is not possible that all items for the unit be shipped together due to availability of transportation and truck space. Confirmation of shipment(s) must be limited to only items on the bill of lading. Filters are shipped on a separate skid in their original packaging. Do not remove factory packaging or install filters until just prior to commissioning. Remove all other shipping/packing materials.

### Handling

Units are to be rigged and moved by the lifting brackets provided or by the skid when a forklift is used. Location of brackets varies by model and size. Handle in such a manner as to keep from scratching or denting. Damaged finish may reduce ability of unit to resist corrosion.

### Storage

Units are protected against damage during shipment. If the unit cannot be installed and operated immediately, precautions need to be taken to prevent deterioration of the unit during storage. The user assumes responsibility of the unit and accessories while in storage. The manufacturer will not be responsible for damage during storage.

The ideal environment for storage of the hood and accessories is indoors, above grade in a clean, dry atmosphere that is sealed from the elements. While in storage, inspect equipment routinely. If any moisture, dirt or other accumulations are found on the hood or any of the parts, the source should be located and eliminated.

### Removing from Storage

As equipment is removed from storage to be installed in their final location, it should be protected and maintained as outlined in the Handling section above.

## Table of Contents

General Safety Information . . . . .	1
Receiving/Unpacking/Handling . . . . .	1
Storage/Removing from Storage . . . . .	1
Auto Scrubber Hood Function . . . . .	2
System Components	
Hood . . . . .	3
Auto Scrubber Control Panel . . . . .	3
Backflow Preventer . . . . .	3
User Interface . . . . .	3
Hood Weights . . . . .	3
Supply Plenum Weights and Dimensions . . . . .	4
Prior to Installation . . . . .	5
Unpacking . . . . .	5
Hood Installation Overview . . . . .	6-7
Filler Panel Installation . . . . .	7
Clearance Reduction Method . . . . .	7-8
Top Clearance Reduction Options . . . . .	7
Back and Front Clearance Reduction Options . . . . .	8
End Clearance Reduction Method . . . . .	8
Installing Duct Collars	
Exhaust Duct Collars . . . . .	8
Supply Duct Collars to the Plenum . . . . .	8
Installing Back Supply Plenum . . . . .	9
Ductwork	
Exhaust/Supply . . . . .	9
Continuous Capture Plenum Hoods . . . . .	9
Installing Front/Side External Supply Plenums . . . . .	10
Uni-Strut . . . . .	10
Hanger Brackets and Threaded Rod . . . . .	10
Supply Duct Collar . . . . .	10
Installing Backsplash / Side Splash Panels . . . . .	11
Installing End Skirts . . . . .	12
Plumbing	
Connections . . . . .	13
Detergent Tank Installation . . . . .	13
Detergent Requirements . . . . .	13
Preventative Maintenance . . . . .	13
Typical Plumbing Connection Layout . . . . .	14
Electrical Connections	
Wiring . . . . .	15-16
Typical Electrical Connection Layout . . . . .	17
Installing Ceiling Enclosure Panels . . . . .	18
Double Island Canopy Style Hoods . . . . .	18
Initial System Start-Up . . . . .	19
System Operation	
Fan Operation . . . . .	20
Hood Light Operation . . . . .	20
Wash Operation . . . . .	20
Wash Sequence of Operation . . . . .	21-22
Airflow Testing Procedure . . . . .	23
Additional Wiring Schematics	
Ansul® and Amerex® Wiring Plan View . . . . .	24
Maintenance	
Filters and Capture Tank . . . . .	25
Auto Scrubber Start-Up Checklist . . . . .	26
Troubleshooting . . . . .	27-29
Replacement Parts . . . . .	30
Maintenance Log . . . . .	31
Our Commitment . . . . .	Backcover

## Auto Scrubber Hood Function

Greenheck's Auto Scrubber hoods are designed for three primary functions:

- Capture and contain the effluent produced by the cooking process.
- Remove grease and other contaminants from the airstream with either one or multiple stages of mechanical filters.
- Wash the filters and other surfaces within the exhaust plenum to remove contaminants.

### NOTE

The wash sequence of the hood is not designed for fire suppression and will not engage in the event of a fire.

### NOTE

For information on the complete wash cycle, please refer to the Wash Sequence of Operation, pages 21 and 22.

## System Components

### Hood

The hood is shipped from the factory pre-piped and ready to install. All wash components within the hood are complete and ready for connection to hot water, sanitary sewer drain and the electrical sources. If the Auto Scrubber Control Panel is mounted on the hood, wiring from the control panel to the hood lights, valves and sensors is completed by Greenheck. All field plumbing and wiring must conform to plumbing and electrical codes.

### Auto Scrubber Control Panel (ASCP)

The control cabinet contains the water and electrical components, including the Programmable Logic Controller (PLC), that controls the wash sequencing and operations. The control cabinet also includes the detergent reservoir, detergent pump, and other water piping.



#### NOTE

Filters are shipped loose with the hood and installed in the field. To install the filters, perform the sequence of steps outlined on page 25 in reverse.

### Backflow Preventer

A backflow preventer will be shipped loose with the ASCP and will need to be installed in-line with the hot water supply to the ASCP to prevent detergent from back-feeding into the building water supply. Plumbing instructions begin on page 13.

### User Interface

The user interface will be either a keypad with LCD screen or touch screen. It can be mounted on the Auto Scrubber control cabinet, hood or shipped loose for remote mounting. It will provide a WASH button (WASH ON/OFF with touch screen), and a means of turning on/off hood fans and lights, if applicable. It also includes system alarm notifications to alert of any faults on the system, such as a low detergent alarm.

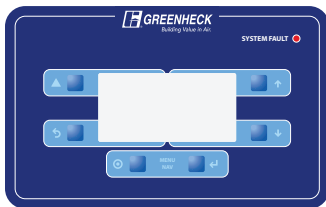

Keypad



Touch Screen

#### NOTE

For detailed information on the Auto Scrubber Control Panel (ASCP), please refer to the Greenheck website, [www.greenheck.com](http://www.greenheck.com)

## Hood Weights

Hood Weights				
Hood Width inches (cm)	Length			
	4 feet lbs. (kg)	8 feet lbs. (kg)	12 feet lbs. (kg)	16 feet lbs. (kg)
48 (121.92)	244 (110.7)	398 (135.2)	553 (250.8)	707 (320.7)
51 (129.54)	250 (113.4)	404 (183.3)	559 (253.6)	713 (323.4)
54 (137.16)	256 (116.1)	410 (186.0)	565 (256.3)	719 (326.1)
57 (144.78)	262 (118.8)	416 (188.7)	571 (259.0)	725 (328.9)
60 (152.40)	268 (121.6)	422 (191.4)	577 (261.7)	731 (331.6)
63 (160.02)	274 (124.3)	428 (194.1)	583 (264.4)	737 (334.3)
66 (167.64)	280 (127.0)	434 (196.9)	594 (269.4)	743 (337.0)
69 (175.26)	286 (129.7)	440 (199.6)	600 (272.2)	749 (339.7)
72 (182.88)	292 (132.4)	446 (202.3)	606 (274.9)	755 (342.5)

#### CAUTION

To ensure proper structural support, all hanger brackets must be used for hanging the hood.

## Supply Plenum Weights and Dimensions

External Supply Plenum Type	Weight		Width		Height		Length per section	
	lbs/ft	kg/m	in.	mm	in.	mm	ft.	m
Air Curtain Supply (ASP)	Refer to Air Curtain Supply Plenum Weight Table	Refer Air Curtain Supply Plenum Weight Table	10 to 24	254.0 to 609.6	10	254.0	3 to 16	.91 to 4.88
Split Air Curtain Supply (Split ASP)	15.5	23.07	24	609.6	10	254.0	3 to 16	.91 to 4.88
Back Supply (BSP)	35.0	52.09	6	152.4	Variable	Variable	3 to 16	.91 to 4.88
Horizontal Supply (HSP)	14.0	20.83	12	304.8	18	457.2	3 to 16	.91 to 4.88
Variable Supply (VSP)	16.0	23.81	12	304.8	18	457.2	3 to 16	.91 to 4.88

Weight	Air Curtain Supply Plenum Width (inches)														
	10	11	12	13	14	15	16	17	18	19	20	21	22	23	24
lbs/ft	8.3	8.6	8.9	9.2	9.5	9.8	10.1	10.4	10.7	11.1	11.3	11.6	11.9	12.2	12.5
kg/m	12.35	12.80	13.24	13.69	14.14	14.58	15.03	15.48	15.92	16.52	16.82	17.26	17.71	18.16	18.60



## Prior to Installation

Prior to installation, check with the Authorities Having Jurisdiction (AHJ) on clearance requirements to structures surrounding the hood and other equipment. Verify there is enough space to safely lift the hood up into its operating position and enough clearance around the hood for components like fire system connections, hood lights, hood control components, plumbing connections, etc. Consider access for servicing the equipment and the different components when locating the hood.

The UL label located on the end panel on the inside of the hood will provide pertinent information regarding the hood installation. Information includes:

- Allowable cooking surface temperatures of the cooking equipment
- Front and side overhang requirements
- Minimum exhaust airflow requirements
- Hood lights load information and restrictions
- Filter information
- Fire damper fusible link replacement information, if applicable

## Unpacking

Carefully remove the top of the crate and set aside all accessories in the crate such as backsplash panels, control packages, and boxes with loose parts. When removing the hood from the crate, place protective material on the floor next to the crate to avoid damaging the hood.

Lift the hood only by utilizing the hanger brackets. Make sure the hood weight is evenly distributed. Slowly lift the hood out of the crate and place on the protective material.

### NOTE

If using straps, the straps should not interfere with plumbing on the top of the hood in an effort to prevent internal piping damage which could cause future leaks.

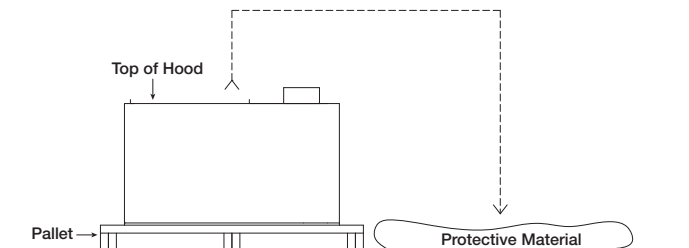

## Hood Installation Overview

It is recommended that the protective plastic sheeting remain on the hood until fully installed to better protect the product from scratching and marking. Once removed, use stainless steel polish, such as BlueAway or equivalent, to clean the hood and/or remove marks or discoloration. Be sure to wipe with the grain and not against it.

1. If the hood is provided with filler panels, shipped loose, install them now. See page 7, Filler Panel Installation. Filler panels may be integral to the hood, which requires no additional installation.
2. If the hood is equipped with Clearance Reduction Methods, refer to pages 7 and 8 for special considerations with hanging the hood.
3. If the hood is provided with hood/duct sensors or thermostats that were shipped loose, install them now. See the Installation and Operations guide provided with the control panel.
4. If the hood was provided with either exhaust collars or supply collars that have shipped loose, it is recommended that the exhaust and supply openings are cut and collars are attached now, prior to hanging the hood. See Installing Duct Collars on page 8.
5. If the hood is provided with a back supply plenum (BSP) install it now. See page 9, Installing the Back Supply Plenum.
6. If possible, connect (weld) exhaust duct to the hood while on the floor, unless it prohibits the hood from being raised into place. For information on ductwork, see page 9, Ductwork.
7. At this point, drill holes in the building structural support system or utilize uni-strut to match up with the hanger bracket holes. Then slowly and evenly raise the hood into position and insert 1/2-inch (12.7 mm) diameter threaded rod (provided by others) between the hanger brackets and structure. The hood hanging height requirements are given on the UL label. Typical canopy hood hanging height will be 80 inches (198.12 cm) off the finished floor.

### NOTE

If the hood is supplied with ceiling enclosure panels, the height of the enclosures will typically be the distance from the ceiling to the top of the hood. Use this dimension to find the hood's hanging height off of the floor.

For questions regarding the supporting structure and its integrity, either the contractor or structural engineer needs to be consulted.

### NOTE

All hanger brackets **MUST** be used and the hood must be properly supported while lifting to prevent damage or distortion to the hood.

### NOTE

Ensure the hood is hung evenly to prevent drainage problems. Provide adequate support so that the hood does not move in a manner that is unacceptable to the Authorities Having Jurisdiction (AHJ).

### WARNING

When mounting the hood or any components against the hood, never puncture or drill into the canopy unless otherwise instructed in this manual. Doing so will void the hood listing and warranty.

8. If the hood was provided in sections with the continuous capture option, once each hood section is hung, install this option now. See page 9, Continuous Capture Plenum Hoods.
9. If the hood was provided with any front or side external supply plenums (other than the back supply plenum), install these now. See page 10, Installing Front/Side External Supply Plenums.
10. Install the remainder of both the exhaust and supply ductwork. For further guidelines see page 9, Ductwork.
11. If the hood is provided with any backsplash/sidesplash panels, install them now. See page 11, Installing Backsplash Panels.
12. If the hood is provided with any end skirts, install them now. See page 12, Installing End Skirts.
13. This is a Type I hood and it requires a fire suppression system. Once the hood(s) and ductwork are fully installed, appliance(s) are in place and walls are complete, the fire system should be completed.

If the hood is provided with a full factory-coordinated fire suppression system installation, the certified fire system installer should be contacted at this time to complete the final hookups, testing and system certification based upon manufacturer's specification and local fire codes.

If the hood is equipped with pre-piping only, and/or does not include fire suppression, it is the responsibility of a certified fire system installer to install, test and certify the system based upon manufacturer's specification and local fire codes.

14. The Auto Scrubber Control Panel (ASCP), if shipped loose, will need to be installed at this time. Once mounted, plumbing and electrical wiring will need to be completed by the jobsite plumber and electrician. Typical site wiring responsibilities include wiring hood temperature sensors, hood lights, hood sequencing valves, fire suppression micro-switches, and fans (if applicable) to the control panel. Hood plumbing details are given on page 13-14, and hood electrical wiring details are provided on page 15-17.

## Hood Installation Overview, *continued*

15. If the hood is provided with enclosure panels, install them now. See page 18, Installing Enclosure Panels.
16. Install the rest of the hood accessories provided. This may include grease filters or condensate hood baffles, grease cups, light bulbs (provided by others unless LED tube style), light globes, and trim strips.

## Filler Panel Installation

1. Uncrate the hood and lay it on the floor with protective material between the hood and the floor.
2. Bolt the filler panels together with 5/16 in. bolts provided in the hardware package.
3. Position the filler panels to the hood back, and tack-weld them into place.

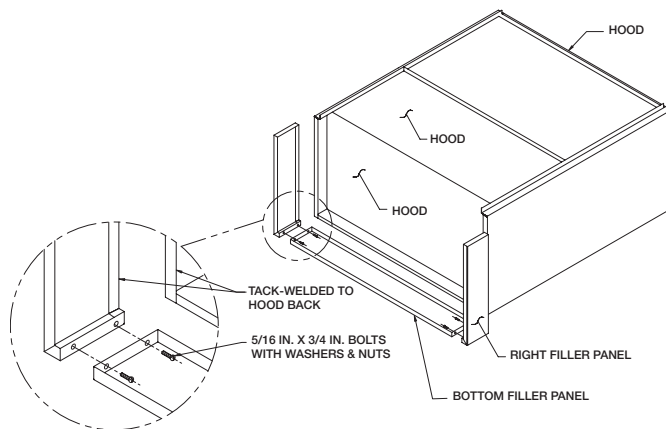

4. To allow for ease of cleaning, caulk the external seams with NSF Approved silicone caulk (GE SCS1009, or its equivalent). The caulk is not provided.

## Clearance Reduction Methods

Clearance reduction methods have been evaluated and tested and are listed by UL (Underwriters Laboratory). The method of test was derived from the UL 710 test standard.

The hood may be installed with zero clearance to combustible materials if constructed in the following manner.

1. One inch (2.54 cm) thick layer of insulation of Owens Corning® Type 475, Johns Manville Type 475, IIG® MinWool-1200® Flexible Batt, or Knauf Insulation Type EI 475.
2. Insulation must be held securely in place. Pins that are welded or secured with an adhesive may be used.
3. A backsplash panel must be attached to the wall (insulated or uninsulated).

To comply with the UL Listing, the cooking appliances must be as follows:

- Maximum surface temperature is 700°F (371°C)
- Appliances are located at least 3 in. (7.62 cm) from the rear wall
- Appliances are at least 40 in. (101.6 cm) below the bottom front edge of the hood

The hood may be installed with 3 in. (7.62 cm) clearance to limited combustible materials per NFPA 96 if constructed in one of the following methods:

- 3 in. (7.62 cm) rear uninsulated stand-off
- 3 in. (7.62 cm) top enclosure panel system
- 3 in. (7.62 cm) end uninsulated stand-off

## Top Clearance Reduction Options

One inch (2.54 cm) layer of insulation installed on top of the hood (optional) meets zero inch requirements for clearance to combustible surfaces as outlined under the clearance reductions methods.

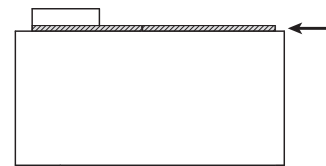

Three inches (7.62 cm) uninsulated airspace installed on top of hood (optional) meets NFPA 96 requirements for clearance to limited combustible surfaces.

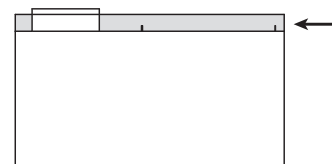

## Back and Front Clearance Reduction Options

One inch (2.54 cm) layer of insulation in 1 in. (2.54 cm) back stand-off meets zero inch requirements for clearance to combustible surfaces as outlined under the clearance reduction methods.

Three inches (7.62 cm) uninsulated back stand-off meets NFPA 96 requirements for clearance to limited combustible surfaces.

One inch (2.54 cm) layer of insulation factory-installed on the front of the hood (optional) meets zero inch requirements for clearance to combustible surfaces.

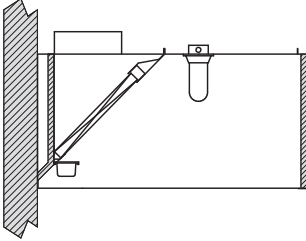

## End Clearance Reduction Options

One inch (2.54 cm) layer of insulation factory-installed on the end of the hood (optional) meets zero inch requirements for clearance to combustible surfaces under the clearance reduction methods.

Three inches (7.62 cm) uninsulated airspace installed on end of hood (optional). Meets NFPA 96 requirements for clearance to limited combustible surfaces.

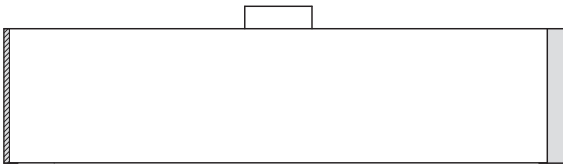

## Installing Duct Collars

### Exhaust Duct Collars

1. The exhaust duct connection needs to be located within 48 in. (121.92 cm) from the center of the hood length to the center of the duct connection and within shaded area as shown.

#### Top View of the Hood

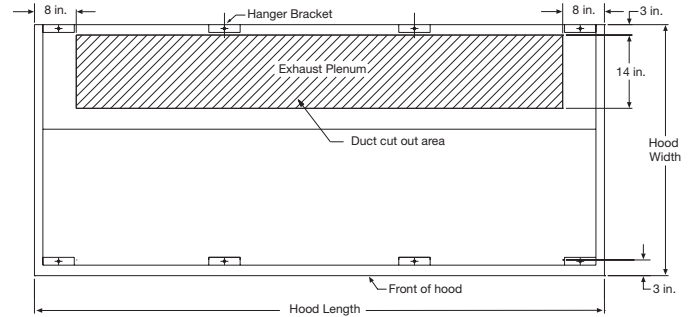

### NOTE

An 8x8x4-inch enclosure and sequencing solenoid valves will be mounted on top of the Auto Scrubber hood near the right or left-hand side. Avoid interference with these items by keeping the exhaust collars 20 inches from the end of the hood where these components are mounted.

2. The exhaust duct connection is to be a continuous liquid-tight weld. Utilizing the 1" (rectangular collars) or 1/2" (round collars) flange, weld with a non-ferrous filler wire, such as silicon bronze or stainless steel filler wire. Protect all stainless steel areas from weld splatter.

### Supply Duct Collars to the Plenum

Place the duct collar(s) over the opening, fastening with tack-welds at 1 to 2 in. (2.54 to 5.08 cm) intervals, or sheet metal screws at 3 to 6 in. (7.62 to 15.24 cm) intervals.

## Installing the Back Supply Plenum

### Install the Supply Duct Collar

1. Find the center of the back supply plenum.
2. If the back supply plenum is to have one opening, cut the opening such that it is centered at  $L/2$  from the plenum end. (Fig. 1)
3. If the back supply plenum is to have two openings, cut openings such that they are centered at  $L/4$  from each end of the plenum. (Fig. 2)
4. Place the duct collar(s) over the opening(s), fastening with screws or tack-welds every 4 to 6 in. (10.16 to 15.24 cm). (Fig. 3)

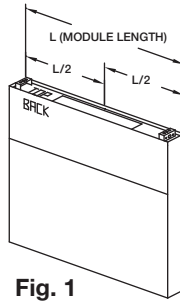

Fig. 1

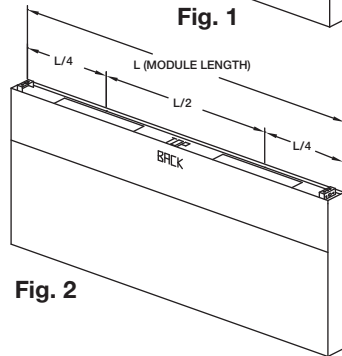

Fig. 2

### Hang the Plenum

5. Hang the back supply plenum from the ceiling.

The back supply plenum needs to be mounted 31.25 in. (79.375 cm) above the finished floor. This is measured from the lowest rear edge of the back supply plenum to the finished floor. (Fig. 4)

Hang using threaded rod placed through the hanger brackets.

6. Fasten the back supply to the wall, going through the lower back supply wall.

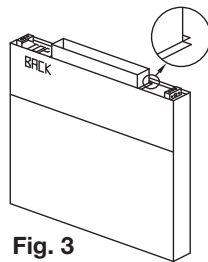

Fig. 3

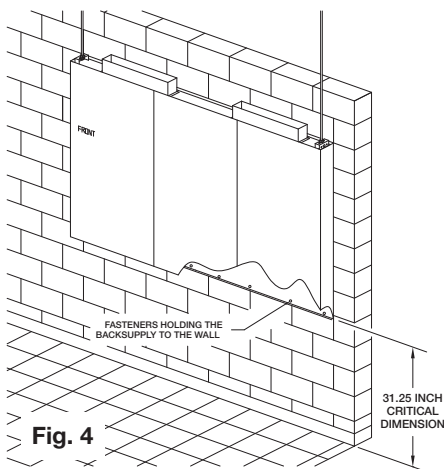

Fig. 4

- These fasteners are to help maintain the location of the back supply, and are not intended to hold the weight of the back supply unit.
- The fasteners should not interfere with the removable air diffusers.

## Ductwork

**Exhaust** - As specified in NFPA 96, Ch. 7.5 (latest edition), exhaust duct systems must be constructed in the following manner:

**Materials:** Ducts shall be constructed of and supported by carbon steel not less than 1.37 mm (0.054 in.) (No. 16 MSG) in thickness, or stainless steel not less than 1.09 mm (0.043 in.) (No. 18 MSG) in thickness.

**Installation:** All seams, joints, penetrations, and duct to hood collar connections shall have a liquid-tight external weld. If you have an automatic fire damper, please refer to that manual for installation instructions now.

**Supply** - Supply ductwork (where applicable) should be connected to the hood in a manner approved by the local code authorities.

### NOTE

For hoods with fire dampers in the exhaust and supply duct collars, an access panel for cleaning and inspection shall be provided in the duct. This panel shall be as close to the hood as possible but should not exceed 18 in. (45.72 cm).

For proper installation of duct collars when they are shipped unattached, see page 8.

## Continuous Capture Plenum Hoods

1. Remove the support angles provided for support during shipping on the open end panels. Install and level both hoods.

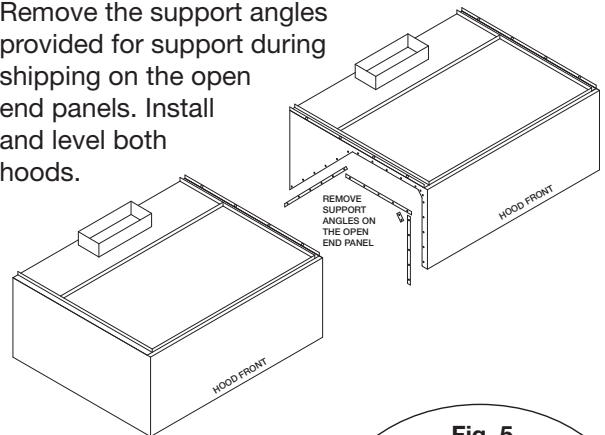
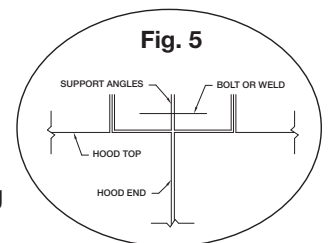

Fig. 5

2. After leveling, secure the hoods together by tack-welding and/or bolting the angles that are located at the top of the hoods along its width (Fig. 5).



3. Next, fasten the hoods together at its inside plenum profile using u-clips and bolts (Fig. 6). Caulk this joint with NSF Approved silicone caulk (GE SCS1009 or its equivalent). The caulk is not provided.

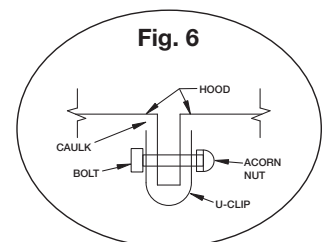
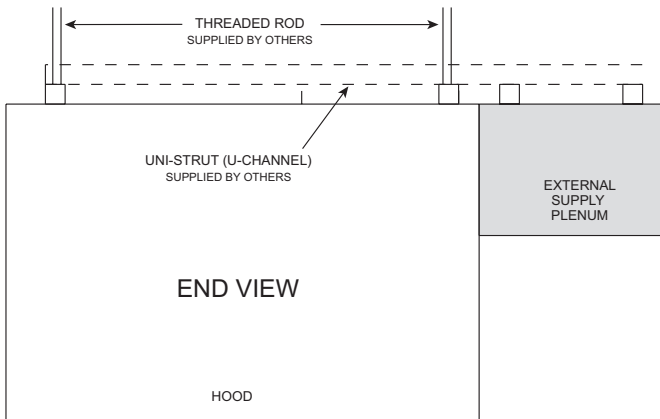

Fig. 6

# Installing Front/Side External Supply Plenums

## Using Uni-strut



The uni-strut (supplied by others) supporting the hood may be cantilevered over the end of the hood. Utilizing the external supply plenum's hanger brackets, securely fasten to the uni-strut.

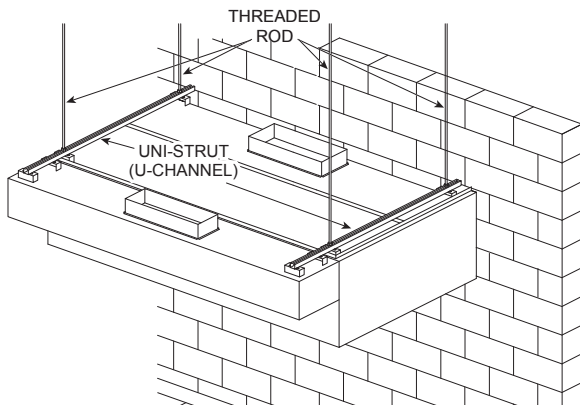

**Air Curtain Supply (ASP)  
Horizontal Supply Plenum (HSP)  
Variable Supply Plenum (VSP)  
Mounted with uni-strut and threaded rod**

When using uni-strut (supplied by others), it must be bolted to the hood and external supply plenum hanger brackets.

### NOTE

The uni-strut needs to be the full length of the hood and the external supply plenum.

## Using Hanger Brackets and Threaded Rod

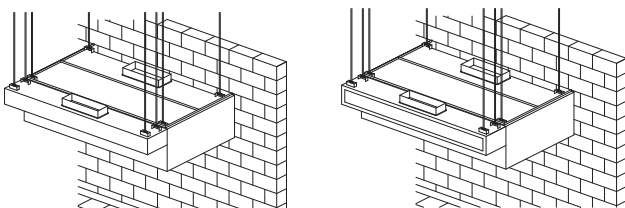

**Air Curtain Supply Plenum (ASP)**

**Horizontal Supply Plenum (HSP)  
Variable Supply Plenum (VSP)**

1. Insert 1/2 in. (12.7 mm) diameter threaded rod (by others) into hanger brackets on the external supply plenum top. Raise and hang the external supply plenum from adequate roof or ceiling supports.

### NOTE

Ensure the external supply plenum is installed flush with the hood front and is plumb and level by adjusting the threaded rod(s). There should be no gap between the bottom of the external supply plenum and the hood after installation and adjustments are completed.

2. The external supply plenum should be resting lightly against the hood. The hood is only used to position the plenum; it is not intended to support the plenum. All hanger brackets on the external supply plenum must be used and the plenum must be properly supported while lifting to prevent damage or distortion. The external supply plenum must be level to operate properly.

### NOTE

After hanging, secure the external supply plenum to the hood (or to another external supply plenum) using the supplied turnbuckle(s). Use caution tensioning the turnbuckle. Too much tension may cause the bottom of the external supply plenum to pull away from the hood or cause the face of the hood to become deformed.

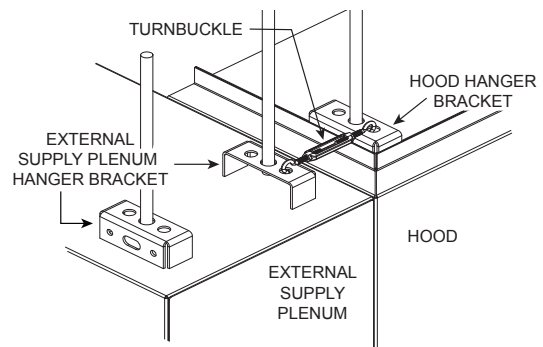

3. It is recommended that caulk be applied at the mating seams and surfaces of the external supply plenum, the hood, and the wall. If the external supply plenum is next to a wall, you will need to caulk around the surface next to the wall. Caulk the joints with NSF Approved silicone caulk (GE SCS1009, or its equivalent). The caulk is not provided.

## Installing the Supply Duct Collar to the Plenum

Place the duct collar(s) over the opening, fastening with tack-welds at 1 to 2 in. (2.54 to 5.08 cm) intervals, or sheet metal screws at 3 to 6 in. (7.62 to 15.24 cm) intervals.

# Installing Backsplash/Sidesplash Panels

## Flat Backsplash/Sidesplash Panel

Material: Stainless

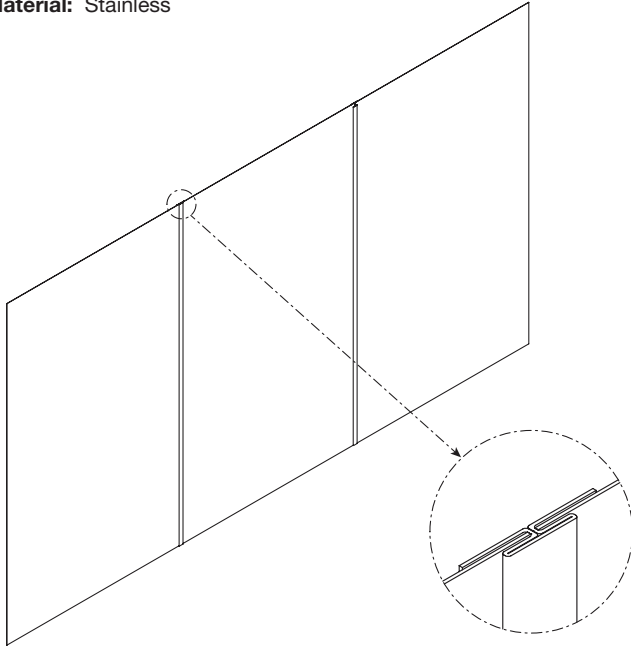

### NOTE

- Panel length up to 47.25 inches (1200.15 mm) wide ship in one piece; panel lengths over 47.25 inches (1200.15 mm) ship in multiple pieces when panel height is <66 inches (1674.4 mm) or >80 inches (2032 mm).
- Panel length up to 48 inches (1219.2 mm) wide ship in one piece; panel lengths over 48 inches (1219.2 mm) ship in multiple pieces when panel height is  $\geq$ 66 inches (1676.4 mm) or  $\leq$ 80 inches (2032 mm).

1. After hood is hung into position, slide the flat flange of the backsplash/sidesplash panel behind the back/side of the hood. If the hood is provided with flat backsplash/sidesplash panels, divider bars will be provided. Install divider bars between panels as shown in the flat backsplash/sidesplash panel section view.
2. After the panels and dividers have been positioned, drill holes in the panel and fasten to the wall. (Fasteners provided by others). The holes should be spaced to adequately secure the panel to the wall.
3. Caulk the joints between the hood and the panel with NSF Approved silicone caulk (GE SCS1009 or its equivalent). Caulk provided by others.
4. Caulk the joint between the panels when multiple insulated panels are required with NSF Approved (GE SCS1009 or its equivalent). Caulk provided by others.

## Insulated Backsplash/Sidesplash Panel

Material: Stainless

Insulation: 1 in. (25.4 mm)

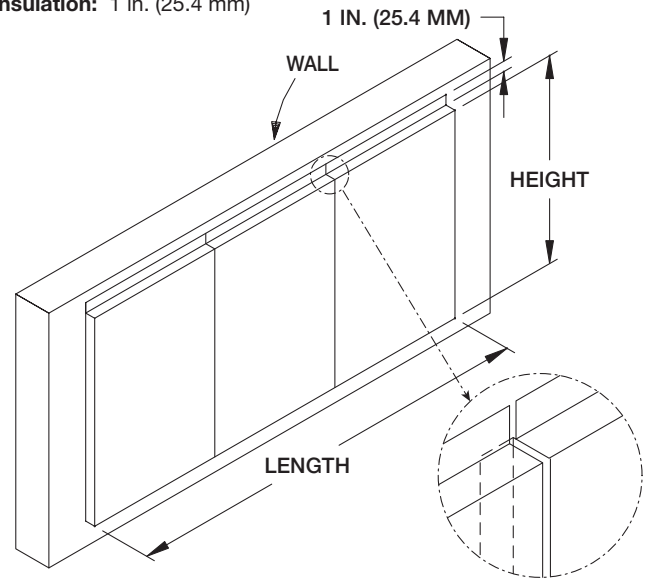

### NOTE

Panels up to 45 in. (1143 mm) wide ship in one piece; over 45 in. (1143 mm) in multiple pieces.

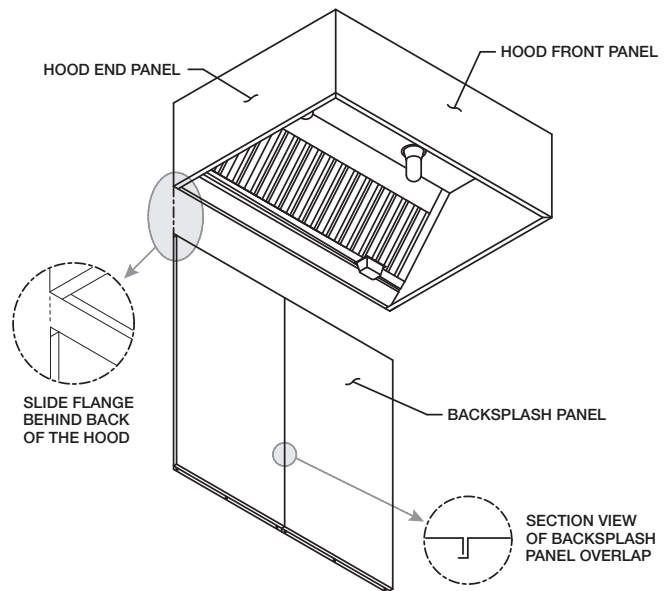

## Installing End Skirts

1. After the hood is hung in position, line up the top of the end skirt with the end panels of the hood.
2. Drill a hole in the hood end panel to line up with the hole in the end skirt. Attach the end skirt with a 1/4 in. bolt and cap nut to the inside of the hood, or tack-weld the end skirt to the hood.
3. Position the end skirt against the wall and attach. The method depends on the wall construction. (Fasteners provided by others).
4. Caulk the internal joint formed by the end skirt and the hood end panel with NSF Approved silicone caulk (GE SCS1009 or its equivalent). The caulk is not provided.
5. To allow for ease in cleaning, also caulk all the external seams.

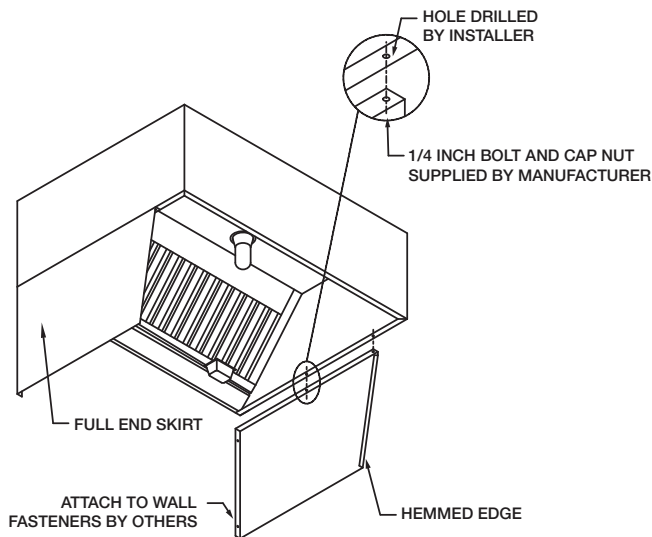

# Plumbing Connections

TOP VIEW OF AUTO SCRUBBER CONTROL PANEL (ASCP)

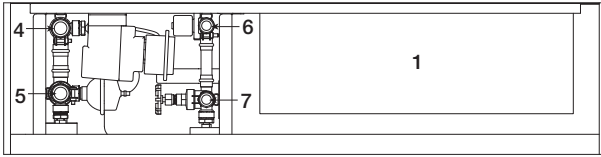

FRONT VIEW OF AUTO SCRUBBER CONTROL PANEL (ASCP)

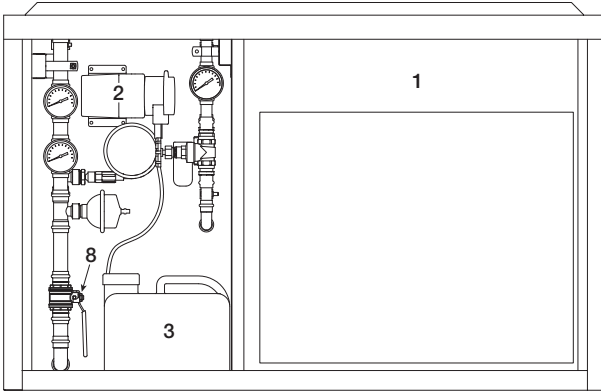

- |  |   |
|--|---|
| 1. Electrical Control Cabinet          | 5. Hot Water Inlet Connection           |
| 2. Detergent Pump                      | 6. Cold Water Outlet Connection to Hood |
| 3. Detergent Tank                      | 7. Cold Water Inlet Connection          |
| 4. Hot Water Outlet Connection to Hood | 8. Inlet Valve                          |

1. Install the factory provided backflow preventer (shipped loose) and drain connection per local codes.

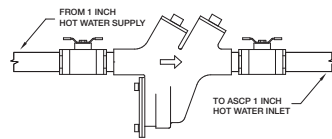

Backflow Preventer

2. Bring 1-inch hot water supply line to the backflow preventer.
3. Plumb 1-inch line from outlet of backflow preventer to the hot water inlet in the control cabinet.
4. If the cabinet is remote mounted, connect the hot water outlet on the controls cabinet to the hot water inlet on the top of the hood.
5. If system is configured for cold water mist, bring 0.75-inch water piping to the cold water mist inlet in the control cabinet.
6. If the cabinet is remote mounted and the system is configured for cold water mist, connect the cold water mist outlet on the controls cabinet to each hood with a cold water mist solenoid valve
7. Plumb 2-inch drain on each hood to grease trap (floor).

## NOTE

- Hot water temperature should be 140°F.
- While the hood is washing, water pressure in the control panel should be between 40 and 70 PSI.
- Cold mist water pressure should be between 20 and 40 PSI.

## Detergent Tank Installation

The detergent tank is located in the plumbing section of the ASCP. The tank provided can hold up to 2.5 gallons of detergent. It will need to be checked periodically depending on detergent use and filled with the recommended chemical detergent. The tank is also equipped with a float that will trigger an alarm to warn the user when detergent is low.

Steps for removal and installation of the detergent tank are as follows:

### Removal:

1. Disconnect the two float switch wires at the quick connect electrical fittings.
2. Remove the 1/4-inch detergent line that enters the tank thru the screw on cap.
3. Lift out the detergent tank from the utility cabinet.
4. Unscrew the 63 mm cap from the tank; this will remove the float assembly.
5. Fill the tank with the approved detergent.

### Install:

1. Install the 63 mm cap and float assembly into the detergent tank.
2. Lift the detergent tank back into the utility cabinet.
3. Install the 1/4-inch detergent line thru the hole in the 63 mm cap.
4. Connect the two float switch wires at the quick connect electrical fittings.

## Detergent Requirements

Detergent model X-701 manufactured by ZEP, Inc., is recommended by Greenheck for use in the wash system. This product is biodegradable, non-caustic, and safe for kitchen staff to use. If X-701 detergent is not used, the cleanliness of the exhaust plenum and filters cannot be guaranteed.

## NOTE

- X-701 is manufactured by ZEP, Inc., Atlanta, GA, USA. For details and ordering information, call 1-800-371-6858.
- If washed once a day, the 2.5 gallon detergent tank will last approximately 24 to 30 days depending on filter type.

## Preventative Maintenance

The following practices will prolong the life of the detergent pump:

- Keep detergent tank filled.
- Avoid spilling detergent on the exterior of the pump.
- Clean the detergent tank at least every six months.
- Clean the detergent line strainer at least every six months.
- Check tightness of all fittings periodically.

The detergent pump motor has sealed bearings which do not require lubrication.

# Typical Plumbing Connection Layout

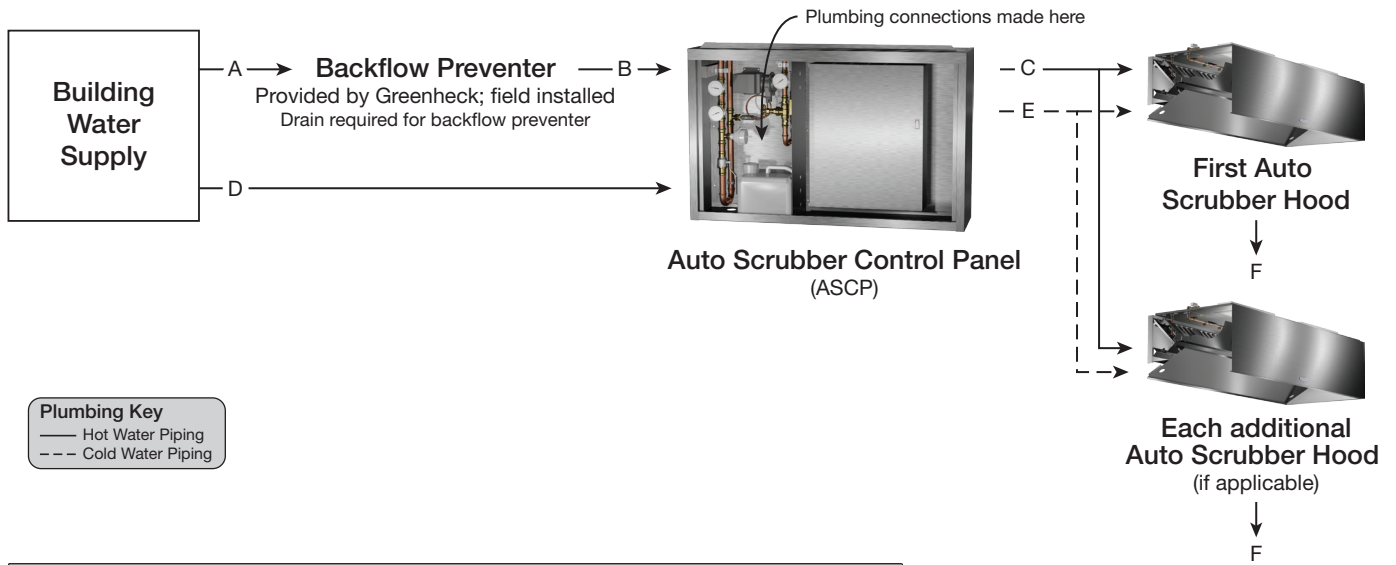

HOT WATER CONNECTIONS:	
A	1-inch hot water supply from building to Backflow Preventer
B	1-inch hot water piping from Backflow Preventer to control cabinet
C	1-inch hot water piping from control cabinet to hood(s)
COLD WATER CONNECTIONS, optional with continuous cold water mist	
D	3/4-inch cold water supply from building to control cabinet
E	3/4 inch cold water piping from control cabinet to hood(s)
DRAIN CONNECTIONS FROM AUTO SCRUBBER HOOD(S):	
F	2-inch male NPT connection to building drain with grease trap (one per hood section)

# Electrical Connections

## NOTE

All wiring of electrical equipment must be done to meet NEC and local codes.

## NOTE

It is recommended that shielded wire be used for all low voltage connections (24V or less) to prevent signal interference with other high voltage circuits.

## WARNING

All 115 VAC field wiring (or higher) must be high temperature rated and must be routed through hard or flex conduit. All low voltage field wiring should be plenum rated if not routed through conduit. All field wiring should not come in contact with the surface of the hood.

This section will provide some field wiring information for connections directly to the hood. For all other wiring connection requirements for the Auto Scrubber Control Panel (ASCP), please refer to both the Auto Scrubber Control Panel Installation, Operation and Maintenance manual and the job specific wiring diagram located on the inside door of the control cabinet.

### Hood Lights

If the hood is provided with lights, a junction box will be located on top of the hood for field connections. Use minimum 14 AWG copper wire. Light bulbs will not be provided (unless equipped with LED tube style fixtures). For incandescent or compact fixtures, standard light bulbs up to 100 watts may be used.

- 115 VAC, power for hood lights, one per light circuit (Terminals H1, N1 | H2, N2 | H3, N3 | H4, N4)
- 115 VAC, power to lights, one per light circuit (Terminals B1, W1 | B2, W2 | B3, W3 | B4, W4)

**EACH CANOPY LIGHTING CIRCUIT MUST NOT EXCEED 15A TOTAL CURRENT**

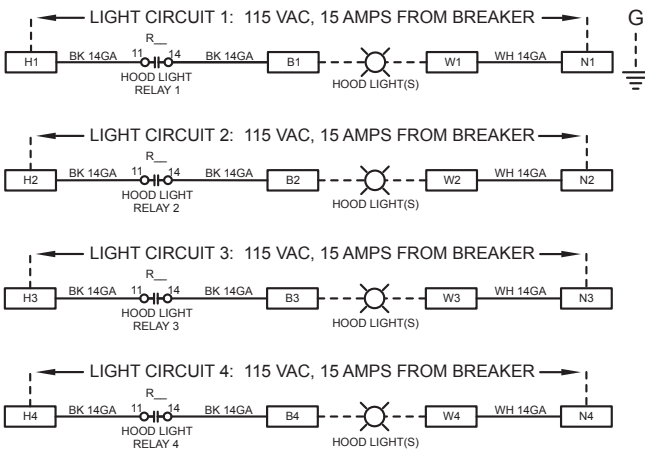

## CAUTION

For multiple hood systems that have more than 14 lights total, incandescent or fluorescent, the hood lights must be wired to multiple circuits. Each circuit must have less than 14 lights total.

### Keypad - if equipped

- Connect factory provided cable from back of keypad to CAREL® PCO5+ controller (Terminal J10)

CONNECT FACTORY PROVIDED RJ25 CABLE TO J10 ON PCO5+ AND BACK OF KEYPAD

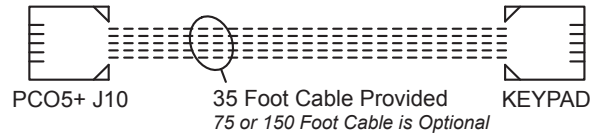

### Touch Screen - if equipped

#### Power Wiring

- Connect factory provided 2-wire cable from Vari-Flow (Terminals TS24, TSC) to touch screen (Terminals G, GO)

#### Control Wiring

- Connect factory provided 3-wire cable from Vari-Flow (Terminals -, +, GND) to touch screen (Terminals -, +, GND)

#### POWER WIRING

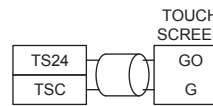

#### CONTROL WIRING

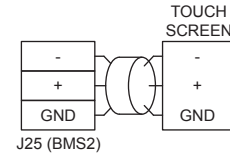

## Electrical Connections, *continued*

### Solenoids and Temperature Sensors

Each Auto Scrubber hood will include an 8x8x4 enclosure factory wired to the hood solenoids and sensors. If the Auto Scrubber Control Panel (ASCP) is not mounted on the hood, the field will need to wire from the 8x8x4 enclosure back to the ASCP. The hood sensors and solenoids are low voltage, therefore, 18 gauge stranded wire is recommended. The two wires of each hood sensor are not polarity sensitive.

The wiring diagram provided with the ASCP will display a table showing which sensors/solenoids connect to each hood. If more than one hood is being controlled, be sure that the appropriate sensor/solenoid is wired to the appropriate terminals as depicted on this diagram.

#### Wash Hood Solenoids

- Wire between control panel terminal WO-\_A and hood j-box terminal WO-\_A
- Wire between control panel terminal WO-\_B and hood j-box terminal WO-\_B
- Wire between control panel terminal 24C and hood j-box terminal 24C
- Wire between control panel terminal GND and hood j-box terminal GND

#### Wash Hood Temp Sensor 1 – *if equipped*

- Wire between control panel terminal T\_-A and hood j-box terminal T\_-A
- Wire between control panel terminal T\_-B and hood j-box terminal T\_-B

#### Wash Hood Temp Sensor 2 – *if equipped*

- Wire between control panel terminal T\_-A and hood j-box terminal T\_-A
- Wire between control panel terminal T\_-B and hood j-box terminal T\_-B

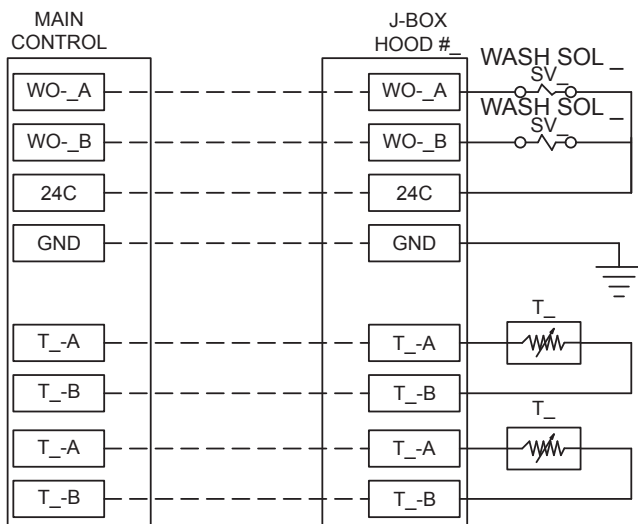

### NOTE

The resistive temperature detectors (RTD), or sensor probes, should not be exposed to direct flame. The RTD's are rated up to 250°F.

### CAUTION

Exposing the sensor to direct flame may render the sensor inoperable and will void the warranty.

# Typical Electrical Connection Layout

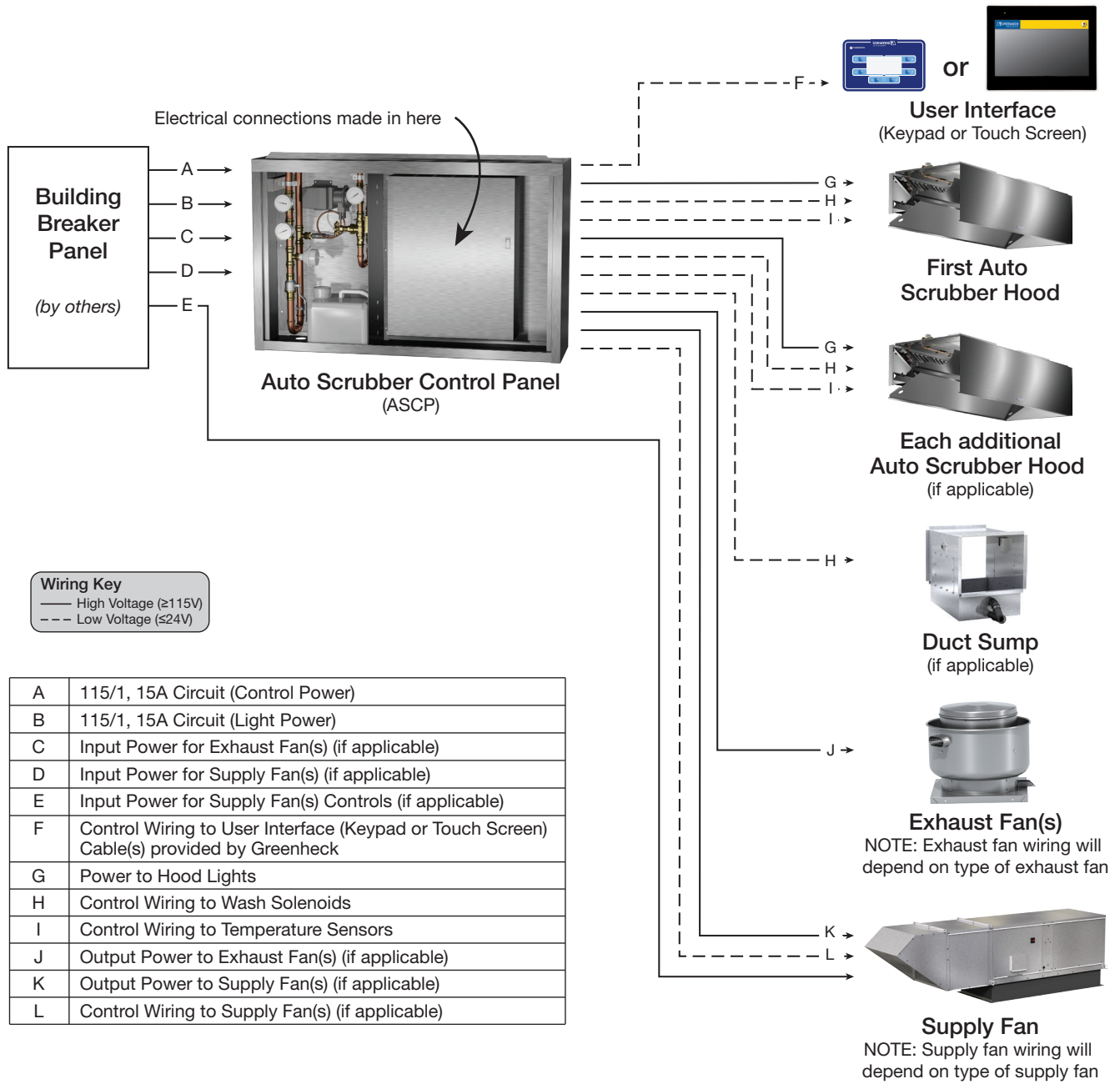

## Installing Enclosure Panels

Before installing the enclosure panels, make sure the hood is hung in position with all the ductwork attached and all fire system and electrical connections completed.

1. Position the end enclosure panels on the hood, and clamp into place with clamps provided or tack-weld the panels into place.
2. Fasten the end enclosure panels to the wall; method depends on wall construction. (Fasteners provided by others).

If the hood is a double island, bolt the end enclosure panels together. (Fasteners provided by others).

3. Position the front enclosure panel(s) on the hood, and bolt to the end enclosure panels with the 5/16 in. bolts provided in the hardware package.
4. Tack-weld or clamp the front enclosure panel(s) to the hood. If clamps are used, they must be positioned 4 in. (10.16 cm) from the ends and in the center of the front enclosure panel.

If hood is provided with supply plenums, the front enclosure panel should be tack welded or use self-tapping screws on the inside of the front panel to secure the panel in place to the ASP.

5. To allow for ease of cleaning, caulk the external seams with NSF Approved silicone caulk (GE SCS1009, or its equivalent). The caulk is not provided.

### NOTE

Installation instructions may not be applicable for concrete ceilings.

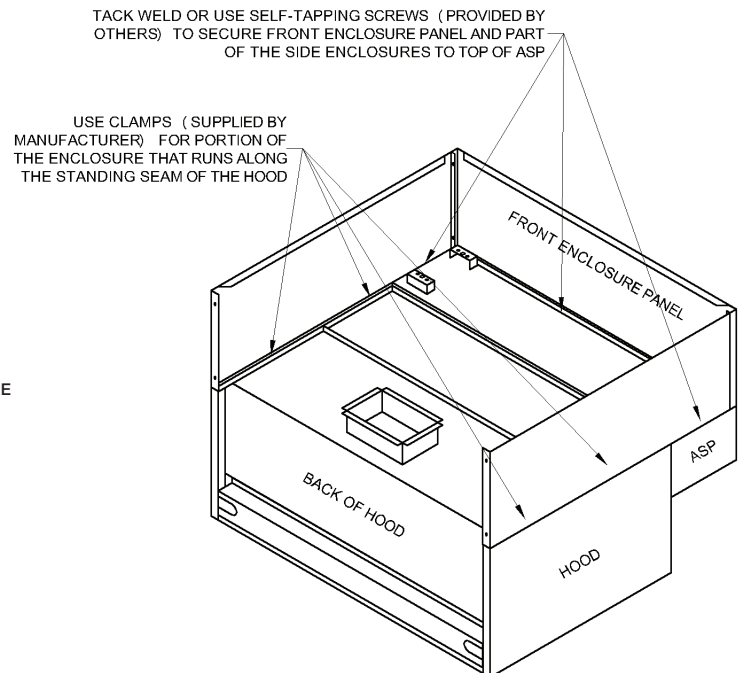
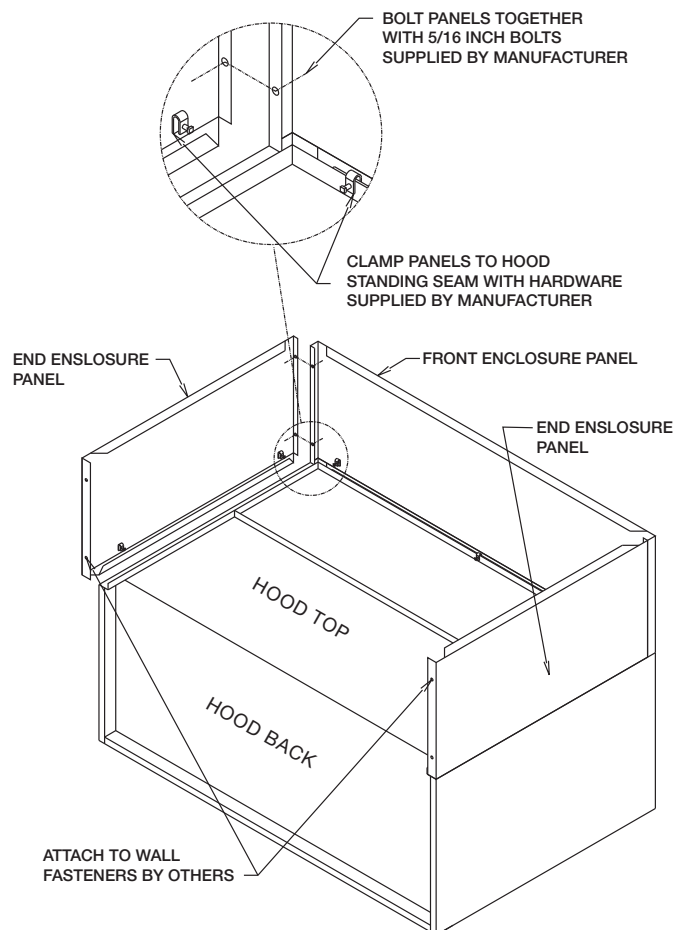

## Double Island Canopy Style Hoods

### NOTE

Before hanging the hoods, please verify the hood marks to ensure the correct hood is hung on the correct side.

A double island hood is created by installing two wall style hoods back to back. Use the installation procedure described for single island canopy hoods; install and level both hoods. After leveling, secure the hoods together by tack-welding and/or bolting the rear mounting brackets together. Double island hoods may also be provided with a U-Channel to seal the seam between the two hoods.

Double island hoods may be provided with a common exhaust duct - if provided, the hoods' exhaust collars will align to form a single exhaust collar to affix the duct to. When a common exhaust duct is not provided, the collars will be separate and not form one collar.

### Installing U-Channel Strip

1. After the hood is hung in position and leveled, apply caulk to the inside edge of the double island clip.
2. Position and install the clip by tapping into position along clip (friction fit).
3. Caulk edges to seal out grease and allow for ease of cleaning. Caulk with NSF Approved silicone caulk (GE SCS1009 or its equivalent). The caulk is not provided.

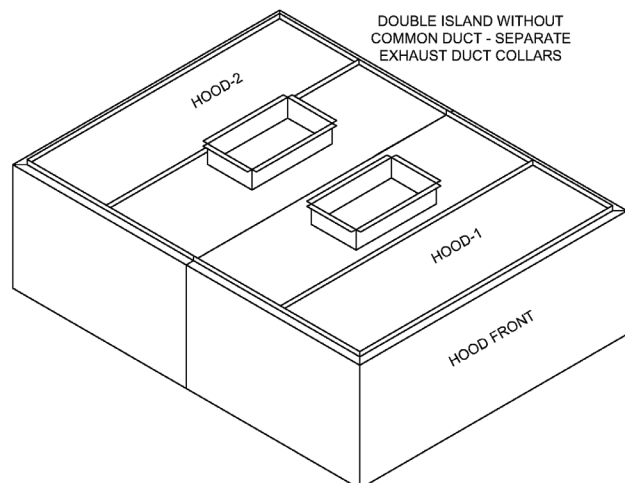
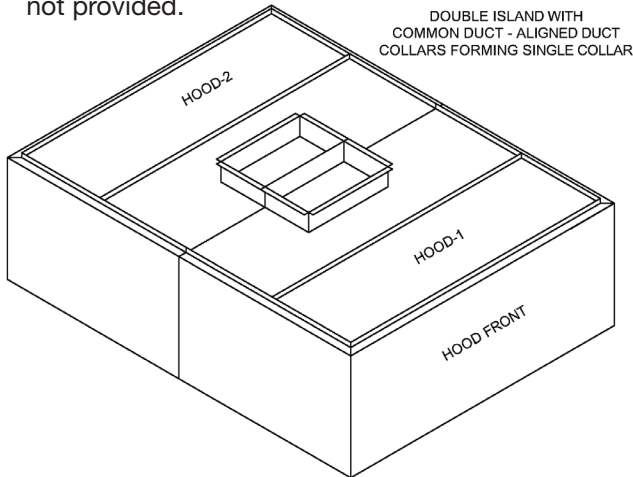

## Initial System Start-Up

1. Clean the control cabinet of any debris that may have entered the cabinet during installation.
2. Add detergent to the detergent tank in the cabinet.
3. Turn power on to the hood and control cabinet and fans (if applicable).
4. Check electrical power is correct for hood controls, lights (if applicable) and fans (if applicable).
5. Confirm the CAREL controller is operational; display should be illuminated.
6. If the system is controlling fans, turn the fans on via the user interface. Check fan rotation and confirm exhaust and supply air volumes are correct (per design). After this has been completed, turn the fans off.
7. Turn on water supply.
8. **Prime the detergent pump.** On the CAREL controller, navigate to Service > Wash Settings > "Prime Detergent Pump" menu screen. Changing "OFF" to "ON" will start the detergent pump.

Monitor the detergent line and press the ESC key once the detergent reaches the hot water line. This will stop the detergent pump.

### Prime Detergent Pump

Prime the detergent pump? OFF

Change NO to YES to start detergent pump.

9. If the filter access doors are not installed, install them now. Instructions for installing filters and access doors can be found on page 25.

### NOTE

Ensure the access doors are installed before starting any wash cycles. Running a wash cycle without the doors in place will result in water spraying on the cooking line-up/area below the hood.

10. **Run a test wash.** On the CAREL controller, navigate to Service > Wash Settings > Hood Test Wash Setup menu screen. Adjust the times as necessary on the screen; change NO to YES. A test wash will start.

### Hood Test Wash Setup

Seq Time:	30s
Seq Det Time:	10s
Drip Dry Time:	10s
Fan Dry Time:	15s
Start Test Wash?	NO

While the hood is washing, ensure water is not leaking through the edges of the access doors or anywhere else in the exhaust plenum. Ensure the grease drain and trap are not plugged, or kitchen flooding may occur.

Water pressure **while the hood is washing** should be between 40 and 70 PSI. Monitor the inlet pressure and temperature gauge in the ASCP through one wash cycle.

At any time, the test wash can be aborted by pressing the ESC key.

## System Operation

### NOTE

The information given in this section provides basic instructions for operating the user interface provided with the Auto Scrubber Control Panel (ASCP). For more detailed information regarding the operation of the control panel, as well as all electrical and plumbing requirements, please reference the Auto Scrubber control panel Installation, Maintenance and Operation Manual. This manual will ship with the control package and can also be found on [greenheck.com](http://greenheck.com)

### Fan Operation (if equipped)

If the hood system is equipped with fan control, start/stop the fans exhausting and supplying the hoods from the user interface.

**KEYPAD** - Press the button next to the “ALL HOODS” text on the keypad to start/stop all of the hoods. If the keypad has a button labeled “HOODS”, pressing this button will navigate to a set of screens where the user can individually start/stop different fans.

**TOUCH SCREEN** - Press the “ALL HOODS ON/OFF” icon on the touch screen to start/stop all of the hoods. If the touch screen has a icon labeled “INDIVIDUAL HOOD SYSTEMS ON/OFF”, pressing this will navigate to a screen where the user can individually start/stop different fans.

### Hood Light Operation (if equipped)

If the hood system is equipped with light control, turn on/off the hood lights from the user interface.

**KEYPAD** - Press the button next to “ALL LIGHTS” text on the keypad to will turn on/off all hood lights. If the keypad has a button labeled “LIGHTS”, pressing this button will navigate to a set of screens where the user can individually start/stop different hood light circuits.

**TOUCH SCREEN** - Press the “ALL LIGHTS ON/OFF” icon on the touch screen to turn on/off all hood lights. If the touch screen has a icon labeled “INDIVIDUAL LIGHT ON/OFF”, pressing this will navigate to a screen where the user can individually turn on/off different hood light circuits.

### Wash Operation (if equipped)

A hood wash can be initiated through a number of different options.

**Wash by Button** (Factory default = **ON**): A wash can be initiated through pressing either the “WASH” button (if equipped with a keypad) or by pressing “WASH ON/OFF” icon (if equipped with a touch screen).

**Wash by Digital Input** (Factory default = **OFF**): A wash can be initiated through engaging a configured digital input on controller. For the correct terminals to wire this digital input, please reference the Auto Scrubber Control Panel wiring diagram.

**Wash by BMS Interface** (Factory default = **OFF**): A wash can be initiated through engaging a BMS read/

write point. Point lists can be found in the Auto Scrubber Control Panel IOM.

**Wash by Scheduler** (Factory default = **OFF**): A wash can be initiated daily at a specific time. If this option is enabled, this time can be field adjusted within the controller and touch screen, if equipped.

**Wash by Auto Start** (Factory default = **ON**): Each individual hood can be washed after that hood’s fan(s) has been running for a pre-determined time (factory default is 8 hours). This time setting and the maximum allowable auto start washes can be field adjusted within the controller and touch screen, if equipped.

### NOTE

Auto Start will only enable to Auto Scrubber hoods. It cannot be used to engage duct sump washes.

With exception to the Auto Start option, when a wash cycle has been initialized the Auto Scrubber hoods will be washed in order starting with Auto Scrubber hood 1. If duct sumps are also connected to this system, they will be washed in order after the Auto Scrubber hoods have been washed.

A wash cycle can be stopped at any time by pressing the “WASH” button (if equipped with a keypad) or by the “WASH ON/OFF” icon (if equipped with a touch screen).

An Auto Scrubber hood will be prevented, or abort operating in the wash cycle, should one of the following events occur:

- A kitchen fire alarm is detected.
- A sensor linked to the Auto Scrubber hood fails.
- The option to disable a wash during temperature interlock is on (factory defaulted on) and a sensor linked to the Auto Scrubber hood exceeds the temperature interlock on setpoint.
- If the Auto Scrubber control panel is equipped with no fan controls (ASCP-W) and the fan input is triggered.

A fan exhausting an Auto Scrubber hood cannot be controlled by the user (turned on and off) while that Auto Scrubber hood is washing. If multiple Auto Scrubber hoods are employed, a fan linked to an Auto Scrubber hood which is not currently washing can be controlled by the user (turned on and off) as normal.

### NOTE

Duct sumps may be controlled by this Auto Scrubber system. A duct sump is a grease reservoir installed in low points of grease duct which also requires routine wash downs.

When duct sumps are washing, fans cannot run, unless:

- A kitchen fire is detected
- A sensor linked to any Auto Scrubber hood fails, or any temperature sensor exceeds the temperature interlock on setpoint
- If the Auto Scrubber control panel is equipped with no fan controls (ASCP-W) and the fan input is triggered

# Wash Sequence of Operation

## NOTE

The previously stated items regarding ending a wash cycle/skipping a hood wash still apply. Please use this in conjunction with the information found in System Operation section found on pages 19 and 20.

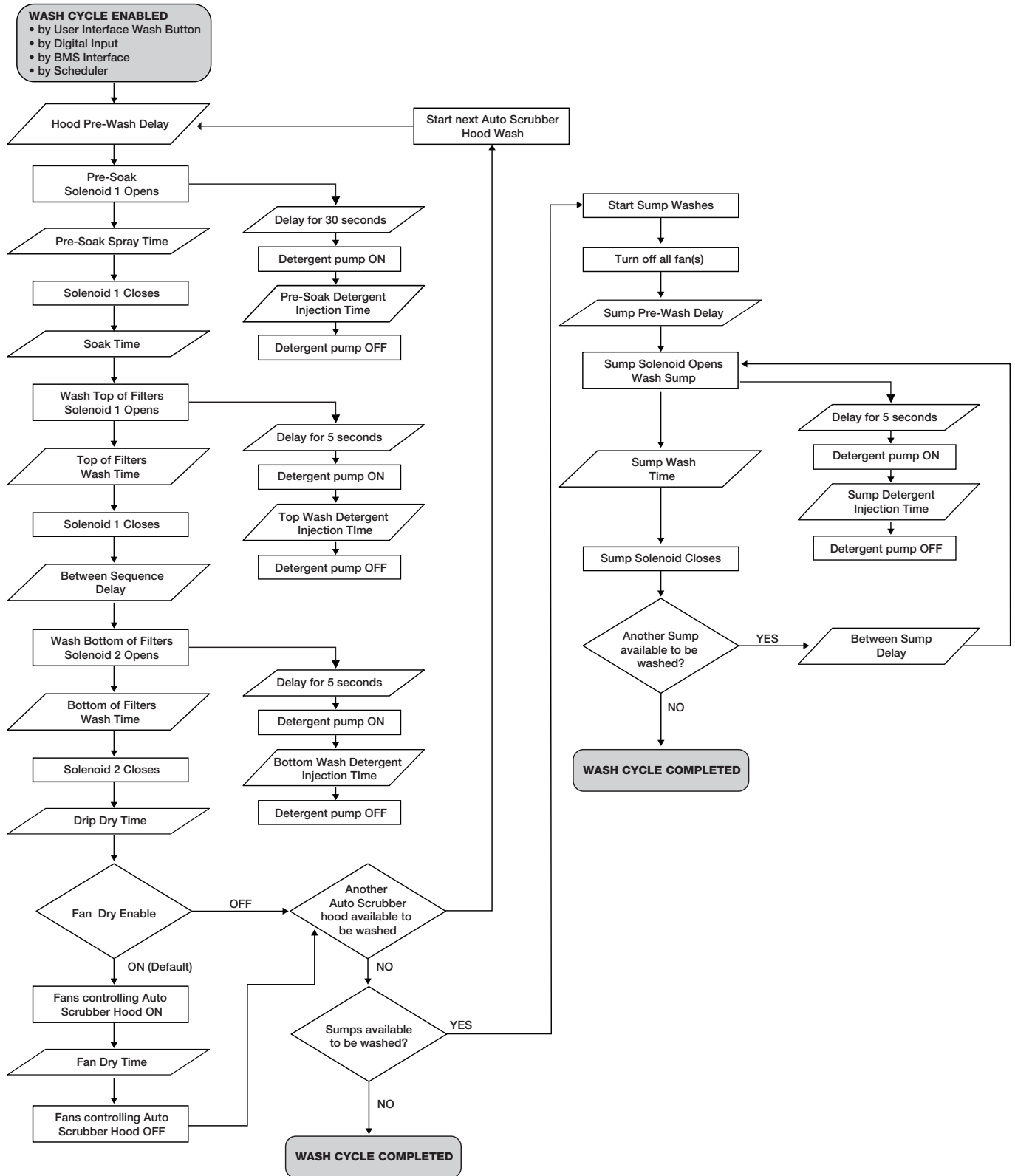

# Wash Sequence of Operation, *continued*

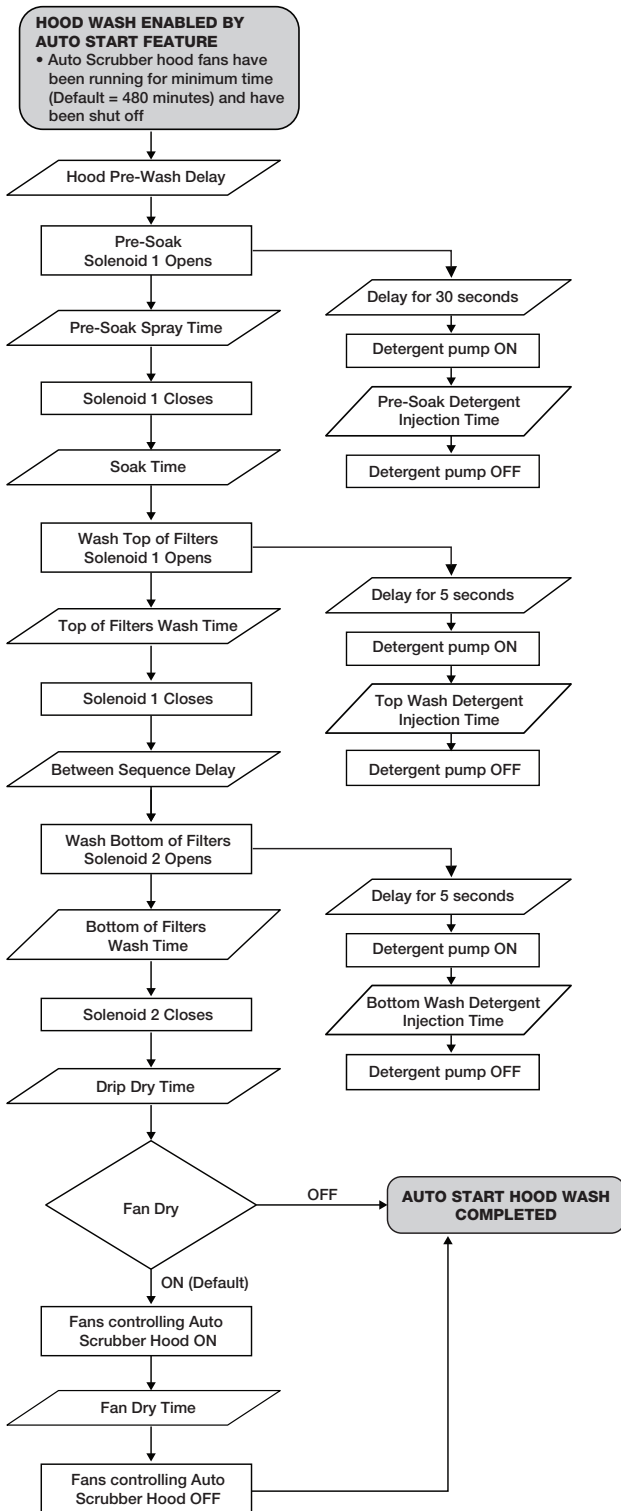

Wash Cycle Stage	Time (seconds) Based on Filter Type	
	Baffle Grease-X-Tractor™ Energy Recovery	Grease Grabber™
Pre-Wash Delay	10	10
Pre-Soak Spray	60	60
Pre-Soak Detergent	30	30
Soak	60	60
Top Wash	120	350
Top Wash Detergent	60	150
Between Sequence Delay	-5	-5
Bottom Wash	120	240
Bottom Wash Detergent	60	60
Drip Dry	60	60
Fan Dry	120	120

**NOTE**  
 The wash times are based on filter cleaning tests using filters coated heavily with oil and then baked-on using high temperatures. Actual required cleaning times will vary based on cooking equipment, fuel type, cooking frequency, and the food prepared. The table shown above should be used as a starting point. After a few weeks, the field can make adjustments as necessary based on the cleanliness of the filters upon removal/inspection (see Maintenance on page 25).



# Airflow Testing Procedure

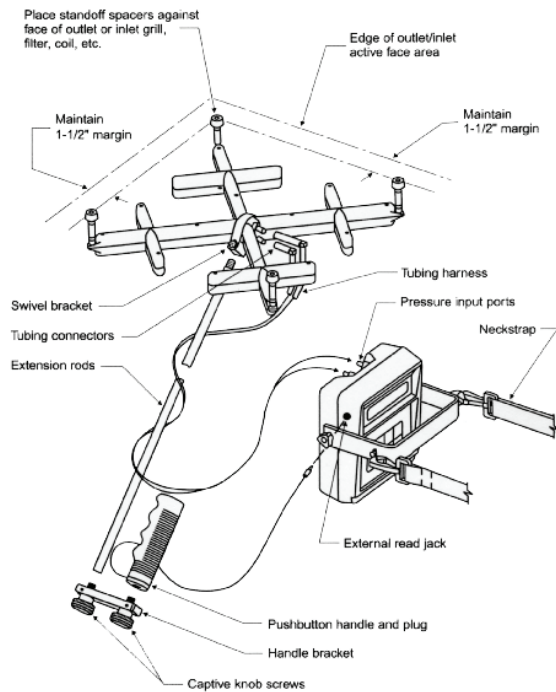

**Short Ridge Meter Components**

For measuring exhaust airflow rates (cubic feet per minute = CFM), use a short ridge meter to measure velocities along the inlet slot of the hood. To ensure accurate data, all appliances should be on. Multiple locations need to be tested as outlined below to ensure an accurate reading.

To take velocity readings along the length of the hood, the short ridge meter must be evenly spaced along the length of each door to provide two readings per door. Vertical placement of the short ridge meter along the inlet slot is shown.

Hood Length	Number of Test Locations
48 to 69 inches	2
70 to 109 inches	4
110 to 139 inches	6
140 to 174 inches	8
175 to 192 inches	10

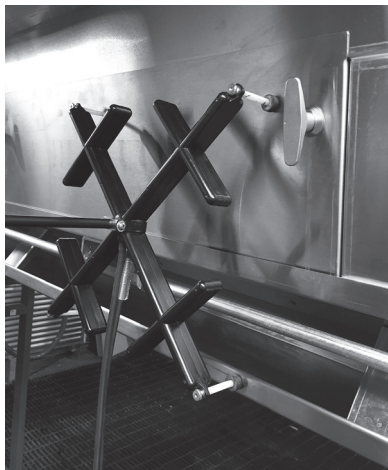

After the appropriate number of readings have been taken from the inlet slot of the hood, an average reading can be calculated by summing the velocity readings and dividing the total value by the number of readings taken.

$$\text{Average Velocity} = \frac{\text{Sum of Velocity Readings}}{\text{Number of Readings}}$$

Next calculate the total hood airflow volume (CFM) by using the following equation:

$$\text{Hood CFM} = [(\text{Length of Hood in inches} \times 3.398) \times (\text{Average inlet slot velocity} \times 3.6)] \div 144$$

**NOTE**

The constants 3.398 and 3.6 are factory derived for use with the Auto Scrubber hood.

**Calculation Example:**

Four (4) inlet slot velocity readings (minimum)

Hood Length	96 inches			
Test Location (left to right; in inches)	6	27	48	69
Velocity Reading (fpm)	224	242	228	236

$$\text{Average Velocity (FPM)} = (224 + 242 + 228 + 236) \div 4 = 233 \text{ FPM}$$

$$\text{Hood Exhaust Rate (CFM)} = [(96 \times 3.398) \times (233 \times 3.6)] \div 144 = 1900 \text{ CFM}$$

# Additional Wiring Schematics

## Ansul® Wiring Plan View

Snap-Action Switches may be wired as shown. Typical examples shown.

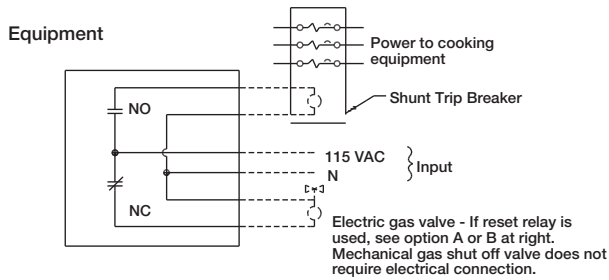

### Alarms

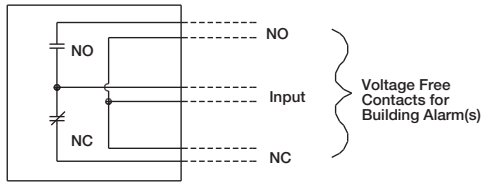

### Fans

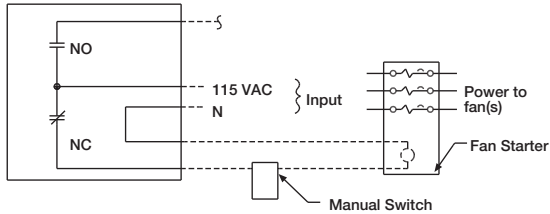

If prohibited by local codes, do not shut down exhaust fans with this method of wiring.

## Manual Reset Relay Part No. 426151

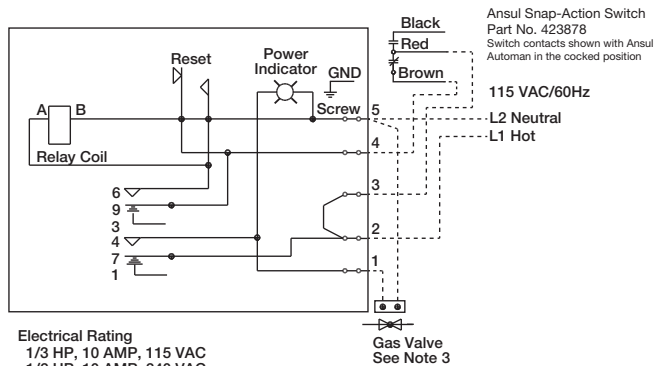

**Electrical Rating**  
1/3 HP, 10 AMP, 115 VAC  
1/2 HP, 10 AMP, 240 VAC  
13 AMP, 28 VDC

### Note:

- Denotes field installation.
- Denotes factory installation.
- Gas Valves: "UL Listed electrically-operated safety valve for natural or LP gas as needed, of appropriate pressure and temperature rating, 115V/60Hz" or Ansul gas valves.
- Do not use black wire on snap-action switch in normal installation. Black wire may only be used for extraneous alarm, light circuits, etc.

## Amerex® Wiring Plan View

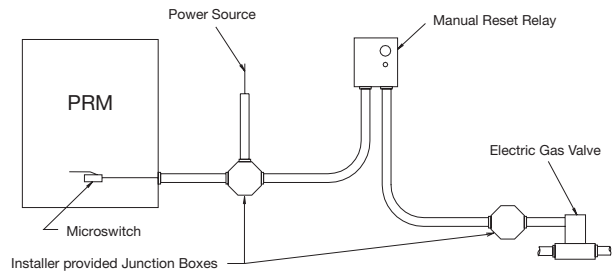

### Basic Wiring Diagram

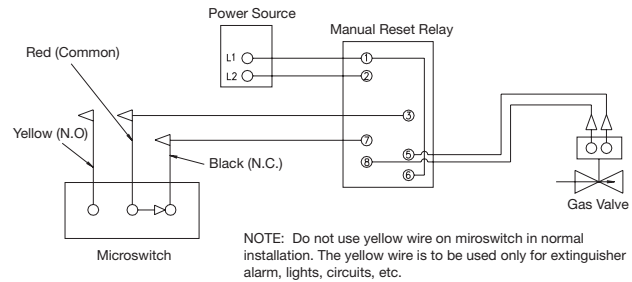

### Basic Wiring Diagram

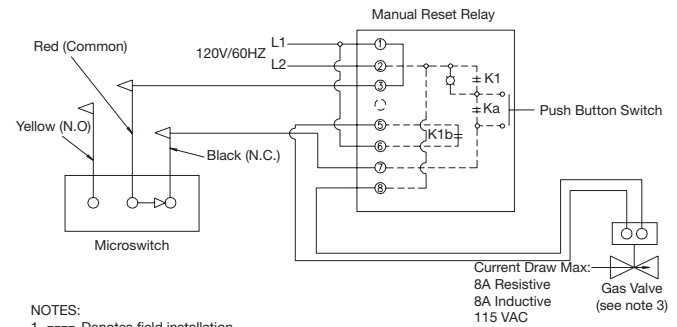

### NOTES:

- Denotes field installation
- Denotes factory installation
- GAS VALVE: UL Listed electronically-operated safety valve for natural or LP Gas as needed of appropriate pressures and temperature rating, 115V/60 Hz or Amerex gas valves, PN 12870, 12871, 12872, 12873, 12874, 12875 and 12876.
- K1a and K1b are N.O. when K1 is de-energized.

# Maintenance

## Filters

The first or primary stage (baffle or Grease-X-Tractor™) filters and second stage (Grease Grabber™) bead filters (if applicable) need to be inspected one week after start up, then once every two weeks to make certain the filters are positioned correctly (no gaps between filters) and that the wash system is adequately cleaning the filters.

To inspect the filters, remove all access doors. Each door is held in place with two cammed latch handles. Turn the handles and remove the doors. *Images 1 and 2.*



Once the doors are removed the filters can be removed. If the hood contains second stage filters, these will also need to be removed. While holding the handles of the filter, push the filter up and lift the bottom of the filter out of its track. Then pull the filter out of the hood. *Images 3, 4 and 5.* Repeat this for all the second stage filters.

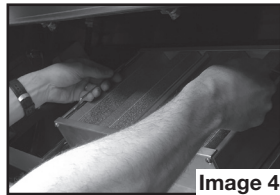

Once the second stage filters are out, (*Image 5*) the first stage filters can be removed in the same manner. *Image 6.*



Depending on the equipment under the hood, it might be easier to remove the filters from the left or right side. In that case, slide the filters towards the end that allows for easier removal.

After inspection, insert the filters back into the hood. Primary filters go in first, then the second stage filters (if applicable). After installing all the filters, make sure the filters are positioned correctly in the hood. There should be no gaps between the filters.

If for some reason the filters don't seem to be getting adequately cleaned, or if the filters appear damaged, consult the factory.

## Capture Tank

The interior surfaces of the hood capture tank should be wiped down weekly.

# Auto Scrubber Start-Up Checklist

Check boxes when item has been verified and reviewed with customer.

## Hook-Up

### Electrical Connections

- Confirm all electrical connections are made per Auto Scrubber Control Panel (ASCP) wiring diagram.
- Turn on all hood, light and fan power (if applicable).
- Check voltages on incoming lines to confirm these are correct.

### Plumbing Connections

- Plumb 1-inch hot water piping to backflow preventer, then from backflow preventer to inlet hot water connection in control cabinet.
- Plumb 0.75-inch cold water piping to inlet cold water mist connection in controls cabinet (if applicable).
- Plumb water connections from controls cabinet to each hood.
- Plumb 0.75-inch cold water piping to cold water mist connection in controls cabinet (if applicable).

### Detergent

- Detergent tank filled with proper detergent.
- Low detergent tubing and strainer should be at the bottom of the detergent tank.
- Prime detergent pump.

## Start-Up

### Test Fan/Light Control Modes (if applicable)

- Confirm fan operation/rotation when enabled/disabled by user interface.
- Confirm hood light operation when enabled/disabled by user interface.

### Run Test Wash

- Test wash instructions on page 20.
- Confirm solenoids and detergent pump are engaging correctly based upon sequence of operation found on pages 21 and 22.

\_\_\_\_\_ Record hot water pressure during wash.  
*Should be between 40-70 PSI*

\_\_\_\_\_ Record cold water mist water pressure, if equipped. *Should be between 20-40 PSI*

\_\_\_\_\_ Record hot water temperature during wash. *Should be 140°F*

- Adjust water pressure if needed using throttling valve. *For cold water mist only.*

## Miscellaneous

### Fire Mode Test

- Trip fire system microswitch. Confirm fan/light operation (if applicable) and wash stopping when in fire mode.
- Alarm message should appear on user interface and main controller.

### Low Detergent Mode

- If removing the float from the tank, the user interface and controller should display a low detergent alarm. Replacing the float in the tank (filled with detergent), the low detergent alarm should disappear.

### Hood Access

- Confirm the hood access panels fit tightly to prevent water from spraying out of the exhaust plenum onto appliances.

### Cleaning

- Is the hood cleaning properly? If not, refer to troubleshooting guide on pages 25 through 27.

## Troubleshooting

### **Problem:** Exhaust fan is not operating or is not operating at design levels.

Is the fan receiving power?	Replace fuses, reset circuit breakers, check disconnect.
Is the belt loose or broken?	Replace or tighten belt.
Is the fan rotating in correct direction?	Have the electrician correctly wire the fan.
Is the make-up air operating?	Problems with make-up air may interfere with the exhaust fan. Check the manufacturer's installation manual.
Does the airflow need to be increased?	Adjust or replace pulleys to increase fan RPM, install a larger motor.
Does the fan vibrate?	Clean the fan wheel/blade, replace fan wheel if damaged, check for loose bolts, check for broken or damaged components, check for rags and other foreign objects.

### **Problem:** Hood is full of smoke. There is smoke coming out of the edges of the hood.

Is the fan operating at design levels?	See exhaust fan troubleshooting section.
Is the fan correctly sized?	Refer to test and balance report, design specifications and fan curves; have an electrician check the motor amperage; try removing the filter temporarily to see if capture improves. (Make sure to replace filter to prevent risk of fire!); switch to different filters with lower static pressure.
Are the filters in good condition?	Clean filters, replace damaged filters, properly position filters.
Is there sufficient make-up air? <i>(Kitchen should be in a slight negative but not excessive. Check to see if there is a strong draft through an open door).</i>	Check make-up air unit. Increase make-up air. Make-up air should be evenly distributed throughout the kitchen.
Does the current cooking equipment match the original design?	Adjust or replace fan to match the cooking equipment load.
Are there multiple hoods on one fan?	One hood may be over exhausting and the other hood not drawing enough. Restrict second hood to help problem hood.
Are there closed dampers in the duct?	Open dampers.
Is the ductwork complex or too small?	Change to a higher static fan, modify the ductwork.
Is the ductwork obstructed?	Clear obstruction.

### **Problem:** Smoke blows away before reaching the bottom of the hood.

Are there cooling fans directed at the hood or cooking equipment?	Turn off or redirect fans.
Are there ceiling diffusers directing air at the hood?	Move diffusers to more neutral area or replace with a diffuser that directs air away from the hood.
Are there open windows or doors?	Close windows and doors.
Are there cross drafts or other drafts in the kitchen?	Find source of the draft and eliminate, add side skirts to hood (test with cardboard; use stainless for permanent side skirts); increase the amount of overhang on the spillage side; add a 6 in. (152.4 mm) lip around the base of the hood (test with cardboard; use stainless for permanent side skirts); make-up air should be spread out evenly through the kitchen.
Is the hood near a main walkway?	Add side skirts to hood (test with cardboard first); increase the amount of overhang on spillage side.
Are there pass-thru windows near the hood?	Adjust amount and locations of make-up air to eliminate drafts through the pass-thru windows.
Is the make-up air entering through an attached plenum?	Try turning off or reducing the amount of make-up air; block off portions of the supply to direct air away from the problem area (test with cardboard).

## Troubleshooting

**Problem:** Pilot lights are being blown out or cooking equipment is being cooled by make-up air.

Are there drafts from make-up air?	Try turning off or reducing the amount of make-up air; block off portions of the supply to direct air away from the problem area (test with cardboard first); remove any obstructions in front of supply that directs air toward cooking equipment.
------------------------------------	---

**Problem:** Cold air can be felt by the cook at the hood.

Is the make-up air entering through an attached plenum?	Try turning off or reducing the amount of make-up air; heat the supply air.
---	---

**Problem:** The kitchen gets hot.

Is the hood capturing?	Hood is not drawing enough air, see sections on fan performance and hood capture.
------------------------	---

Is the make-up air entering through an attached plenum?	Try turning off or reducing the amount of make-up air; cool the supply air.
---	---

**Problem:** Cooking odors in the dining area.

Is the hood capturing?	Hood is not drawing enough air, see sections above on fan performance and hood capture.
------------------------	---

Is there a draft through doors between the kitchen and dining area?	Decrease make-up air in the kitchen; increase exhaust air through hood.
---	---

**Problem:** Grease is running off the hood.

Is there grease on top of the hood?	Exhaust duct is not correctly welded.
-------------------------------------	---------------------------------------

Is the caulk missing or damaged?	Clean problem area and recaulk.
----------------------------------	---------------------------------

**Problem:** Hood is noisy.

Is the fan running in the correct direction?	See exhaust fan troubleshooting section.
--	--

Are the filters in place?	Replace missing filters.
---------------------------	--------------------------

Is the hood over exhausting?	Slow down fan (see exhaust fan troubleshooting section)
------------------------------	---

## Troubleshooting

---

**Problem:** An Auto Scrubber hood is not washing routinely (wash cycle not activating).

Is the system in fault?	Fire, high temperature and sensor faults will prevent a wash from starting. Correct these faults.
Are you relying on the hood to wash manually?	In the control panel Wash Enable option, verify the setting for “Wash by Button” is set to ON. Ensure (recommended after start up) the kitchen employees are pressing the WASH button daily.
Are you relying on the hood to wash automatically?	In the control panel Wash Enable option, verify “Wash by BMS”, if the BMS is controlling the hood wash, or “Wash by Scheduler” or “Wash by Auto Start” are set to ON. Adjust these settings with factory advice.
Are the wash solenoids opening/closing?	Check voltage at each solenoid to confirm voltage when a solenoid should be opening. If the solenoid is receiving voltage but the valve is not opening, the valve may be stuck and need replacement.

---

**Problem:** Auto Scrubber hood is washing routinely but is not cleaning the filters properly.

Is the water temperature hot enough?	Correct water temperature plumbing to the hood. Adjust delay times between Auto Scrubber hoods to allow for the facility hot water heater to be able to heat longer.
Is the detergent empty? <i>Detergent alarm will be present</i>	Refill the detergent
Are you using the correct detergent?	Use recommended detergent; see page 13.
Are the cooking loads very heavy?	Increase the washing frequency. Increase the wash cycle and detergent timers for each sequence.
Are the nozzles clogged?	Clean/replace the nozzles.

---

**Problem:** Hood is leaking water.

Are the access doors in place?	Make sure the access doors are in place and completely sealed.
Is condensation forming in the hood?	Hood should not be washed when food equipment is warm (not hot). Water pressure may be too high. Reduce the water pressure.
Where is the hood leaking water?	Contact the factory for further advice if the access doors are in place.

---

## Parts List

---

Part Number	Description
385987	Detergent Float
481461	Wash Nozzle
456767	Cold Water Mist Nozzle
481463	24V Coil for Solenoid
381050	3/4-inch Solenoid Valve
456765	Pressure Gauge
479363	Temperature Gauge
851709	16H x 16W Grease-X-Tractor™ SS Filter
851710	16H x 20W Grease-X-Tractor™ SS Filter
852881	16H x 16W Grease Grabber™ Second Stage Filter
852880	16H x 20W Grease Grabber™ Second Stage Filter
457627	16H x 16W Stainless Steel Baffle Filter
457629	16H x 20W Stainless Steel Baffle Filter



# Maintenance Log

Date \_\_\_\_\_ Time \_\_\_\_\_ AM/PM  
Notes: \_\_\_\_\_

\_\_\_\_\_  
\_\_\_\_\_  
\_\_\_\_\_

Date \_\_\_\_\_ Time \_\_\_\_\_ AM/PM  
Notes: \_\_\_\_\_

\_\_\_\_\_  
\_\_\_\_\_  
\_\_\_\_\_

Date \_\_\_\_\_ Time \_\_\_\_\_ AM/PM  
Notes: \_\_\_\_\_

\_\_\_\_\_  
\_\_\_\_\_  
\_\_\_\_\_

Date \_\_\_\_\_ Time \_\_\_\_\_ AM/PM  
Notes: \_\_\_\_\_

\_\_\_\_\_  
\_\_\_\_\_  
\_\_\_\_\_

Date \_\_\_\_\_ Time \_\_\_\_\_ AM/PM  
Notes: \_\_\_\_\_

\_\_\_\_\_  
\_\_\_\_\_  
\_\_\_\_\_

Date \_\_\_\_\_ Time \_\_\_\_\_ AM/PM  
Notes: \_\_\_\_\_

\_\_\_\_\_  
\_\_\_\_\_  
\_\_\_\_\_

Date \_\_\_\_\_ Time \_\_\_\_\_ AM/PM  
Notes: \_\_\_\_\_

\_\_\_\_\_  
\_\_\_\_\_  
\_\_\_\_\_

Date \_\_\_\_\_ Time \_\_\_\_\_ AM/PM  
Notes: \_\_\_\_\_

\_\_\_\_\_  
\_\_\_\_\_  
\_\_\_\_\_

Date \_\_\_\_\_ Time \_\_\_\_\_ AM/PM  
Notes: \_\_\_\_\_

\_\_\_\_\_  
\_\_\_\_\_  
\_\_\_\_\_

Date \_\_\_\_\_ Time \_\_\_\_\_ AM/PM  
Notes: \_\_\_\_\_

\_\_\_\_\_  
\_\_\_\_\_  
\_\_\_\_\_

Date \_\_\_\_\_ Time \_\_\_\_\_ AM/PM  
Notes: \_\_\_\_\_

\_\_\_\_\_  
\_\_\_\_\_  
\_\_\_\_\_

Date \_\_\_\_\_ Time \_\_\_\_\_ AM/PM  
Notes: \_\_\_\_\_

\_\_\_\_\_  
\_\_\_\_\_  
\_\_\_\_\_

Date \_\_\_\_\_ Time \_\_\_\_\_ AM/PM  
Notes: \_\_\_\_\_

\_\_\_\_\_  
\_\_\_\_\_  
\_\_\_\_\_

Date \_\_\_\_\_ Time \_\_\_\_\_ AM/PM  
Notes: \_\_\_\_\_

\_\_\_\_\_  
\_\_\_\_\_  
\_\_\_\_\_



## Our Commitment

---

*As a result of our commitment to continuous improvement, Greenheck reserves the right to change specifications without notice.*

Product warranties can be found online at [Greenheck.com](http://Greenheck.com), either on the specific product page or in the literature section of the website at [Greenheck.com/Resources/Library/Literature](http://Greenheck.com/Resources/Library/Literature).

AMCA Publication 410-96, Safety Practices for Users and Installers of Industrial and Commercial Fans, provides additional safety information. This publication can be obtained from AMCA International, Inc. at [www.amca.org](http://www.amca.org).

