



H&K DALLAS INC.
“Our Quality Shines Through”



PORTABLE MEAT FREEZER MF03

H&K DALLAS INC., 1343 S.HENDERSON AVE., DALLAS, TX 75223.



TABLE OF CONTENTS

WARNINGS	1
INTRODUCTION	2
WARRANTY STATEMENT	2
SERVICE INFORMATION.....	3
POWER REQUIREMENTS.....	3
INSTALLATION	4
OPERATING PROCEDURE	4
MAINTENANCE	5
TROUBLESHOOTING	6
UNIT PRINT	7
ELECTRICAL SCHEMATIC	8
CONDENSING UNIT SPECIFICATIONS	9
OPTIONS.....	10
REPLACEMENT PARTS	10
240V/50HZ SCHEMATIC	11



WARNINGS!!!

DO NOT OPERATE OR SERVICE THE FREEZER WITHOUT FIRST READING THIS MANUAL.

DISCONNECT ALL POWER SOURCES BEFORE ATTEMPTING ANY SERVICE OR REPAIR WORK.

DO NOT ADJUST THE DIFFERENTIAL SCREW ON THE THERMOSTAT.

A LICENSED TECHNICIAN SHOULD DO ALL SERVICING AND REPAIR.

USE OF ABRASIVE PADS TO CLEAN THE UNIT WILL RESULT IN SCRATCHING AND SPOILING THE FINISH OF THE UNIT.

DO NOT LEAVE THE SLIDING COVER OPEN FOR EXTENDED PERIOD OF TIME.



INTRODUCTION

The MF03 meat freezer is designed to hold all boxes of patties that are kept frozen, at the desired temperature during normal and peak sales periods.

WARRANTY STATEMENT

H&K makes the following limited warranties to the original purchaser only for this equipment and replacement parts:

H&K warrants all components to be free of defects in material and workmanship, if properly installed, operated and maintained, for a period of one (1) year from the date of the delivery.

The company's obligation under this warranty is limited to repairing or replacing any part or parts of the Freezer determined to be defective by an authorized representative of H&K.

The company reserves the privilege of determining if such repairs are to be made in the field or at the H&K factory.

The company assumes no liability for expenses or repairs made by other parties except by written consent.

Corrections of such defects by repair or replacement shall constitute fulfillment of all company obligations to the purchaser.



H&K shall not be liable for loss, damages or expenses arising from misuse, abuse, alteration, accident or improper installation of the Freezer such as:

- ? Improper or unauthorized repair;
- ? Failure to follow proper installation instruction;
- ? Improper maintenance;
- ? Damage in shipment;
- ? Abnormal use;
- ? Improper power supply;
- ? Natural disaster;

This warranty also does not cover:

- ? Transportation or travel over 100 miles (160 Km) or travel time over 2 hours;
- ? Overtime or holiday charges;
- ? Consequential damages (the cost of repairing or replacing other property which is damaged), loss of time, profits, or any other incidental damages of any kind.

SERVICE INFORMATION

If you experience any technical problems with this product, please call
(214)-818-3500.

POWER REQUIREMENTS

All electrically operated appliances must be electrically grounded in accordance with local codes, or in the absence of local codes, with National Electric Code, ANSI/NFPA No. 70-1990.

Compressor
Voltage = 120 V AC
Frequency = 60 Hz.
Current = 9.1 Amps.
Single Phase



INSTALLATION

1. **Inspection:** Upon receipt, examine the equipment carefully for any damage. If damage has occurred, notify the carrier and H&K immediately..
2. **Unpacking:** Remove the unit from the plastic wrap and untie the electrical cord by removing the holding tape. It is recommended that the unit remain crated until it has reached the installation location.
3. **Location:** The location of the freezer should be away from extreme heat and cold. Enough clearance should be allowed around the freezer to facilitate easy closing and opening of the sliding cover.
4. **Leveling:** In order to provide adequate condensate drainage, it is imperative that the unit be level. The floor where the unit is located should be level.

OPERATING PROCEDURE

1. **Power Source:** Insert the plug of the freezer into a standard 120V AC 60 Hz. Outlet. The unit consists of one compressor. Other motors and heavy appliances should not be used on the same circuit with the freezer.
2. **Start-Up:** The freezer is turned ON by plugging the cord into the outlet and check if the condenser fan is running. Let the unit run for 1 hour before placing product in the freezer.
3. **Temperature Setting:** The unit has been tested at the factory and the thermostat has been set to maintain a temperature between -10 and 0°F (-23.3 and -17.7°C).
4. **Thermostat Adjustment:** If the unit does not hold the desired temperature, the thermostat can be adjusted. For colder temperatures, turn knob clockwise one number at a time. For warmer temperature setting, turn knob anti-clockwise one number at a time.



Wait for 1 hour before readjusting the thermostat. Excessive tampering with the thermostat may lead to service difficulties.

5. **Condensate Disposal:** The condensate from the freezer is disposed via a drain at the bottom of the freezer.

CAUTION: Do not leave the freezer cover open for extended period of time.

MAINTENANCE

1. **Exterior Cleaning:** The exterior of the unit should be cleaned with a soap and water mixture. Do not use abrasive cleaners to clean the exterior of the cabinet as this might damage the stainless steel finish. Do not use steel wool or any strong chemicals.
2. **Interior Cleaning:** The anodized aluminum interior of the freezer can be cleaned using a soft sponge and a soap-water mixture. The pilasters can be removed without tools to aid in cleaning the interior.
3. **Condenser:** For proper operation of the condensing unit the condenser fins and fans should be cleaned and vacuumed every 3 months. The front grill is designed to be removable for this purpose.



TROUBLESHOOTING

PROBLEM	CAUSE	SOLUTION
Compressor will not start	<ol style="list-style-type: none"> 1. Cord set not plugged in. 2. Thermostat stuck in open position. 3. Improperly wired. 4. Low voltage to unit. 	<ol style="list-style-type: none"> 1. Plug in cord. 2. Replace thermostat. 3. Check wiring against diagram. 4. Correct the voltage.
Unit short cycles	<ol style="list-style-type: none"> 1. Differential set too close. 2. Overcharge. 3. Undercharge. 	<ol style="list-style-type: none"> 1. Increase differential. 2. Reduce charge. 3. Fix leak, add refrigerant.
Unit runs continuously	<ol style="list-style-type: none"> 1. Undercharge. 2. Bad thermostat. 3. Dirty condenser. 	<ol style="list-style-type: none"> 1. Add refrigerant. 2. Replace thermostat. 3. Clean condenser fins.
Condensation	<ol style="list-style-type: none"> 1. Leak in Gasket. 2. Wiring to condensate heater faulty. 	<ol style="list-style-type: none"> 1. Reinstall gasket properly. 2. Rewire condensate heater.
Unit noisy	<ol style="list-style-type: none"> 1. Loose parts or mounting. 2. Fan motor bearings worn. 3. Fan blade bent. 4. Compressor assembly rattling. 	<ol style="list-style-type: none"> 1. Tighten parts. 2. Replace motor. 3. Replace fan blade. 4. Check if mounted correctly and securely.
Temperature too high.	<ol style="list-style-type: none"> 1. Temperature setting too high 2. Overcharge. 3. Condenser fins blocked. 4. Restricted air flow. 	<ol style="list-style-type: none"> 1. Reset temperature 2. Reduce Charge. 3. Clean Fins. 4. Ensure air can circulate around the unit.
Compressor short cycles on overload protector.	<ol style="list-style-type: none"> 1. Additional current through overload protector. 2. Run capacitor defective. 	<ol style="list-style-type: none"> 1. Check wiring diagram. 2. Replace run capacitor.

NOTE: All troubleshooting must be performed by a certified technician.

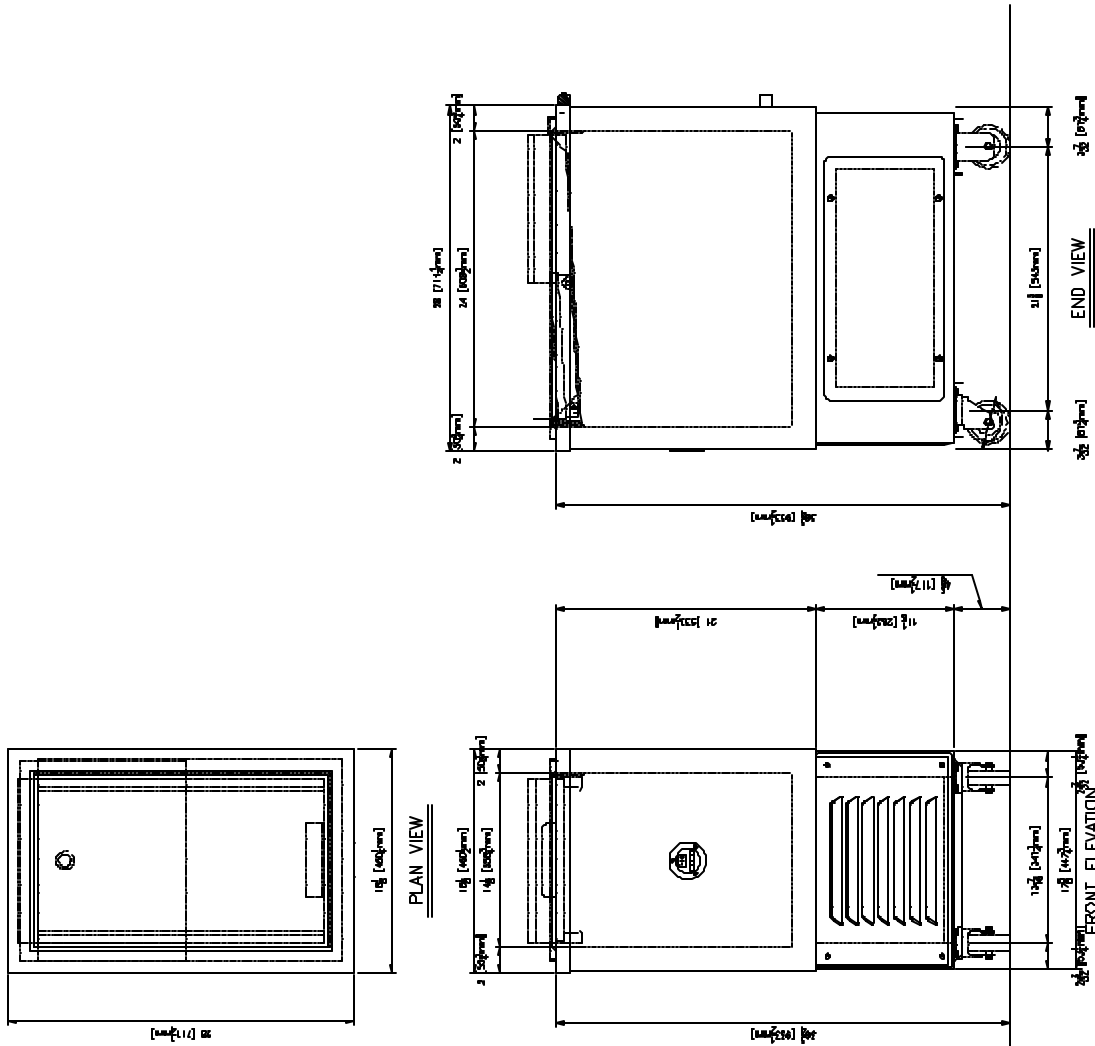

SHEET NO.	CUSTOMER: McDONALD'S CORPORATION	TITLE: ASSEMBLY, MOBILE SINGLE MEAT FREEZER 95 SERIES	DATE: 18JUN95	SYM	REVISION	DATE	SCALE: 3" = 1'-0"		
	DRAWN: TONG NGUYEN		-	-	-				
STORE NO.:	ITEM NO. NF03	SHEET: 1 OF 2	<small>THESE DIMENSIONS REPRESENTATIONS ARE THE PROPERTY OF H&K AND SHALL NOT BE REPRODUCED OR COPIED WITHOUT H&K'S WRITTEN PERMISSION.</small>		COMMENTS:				

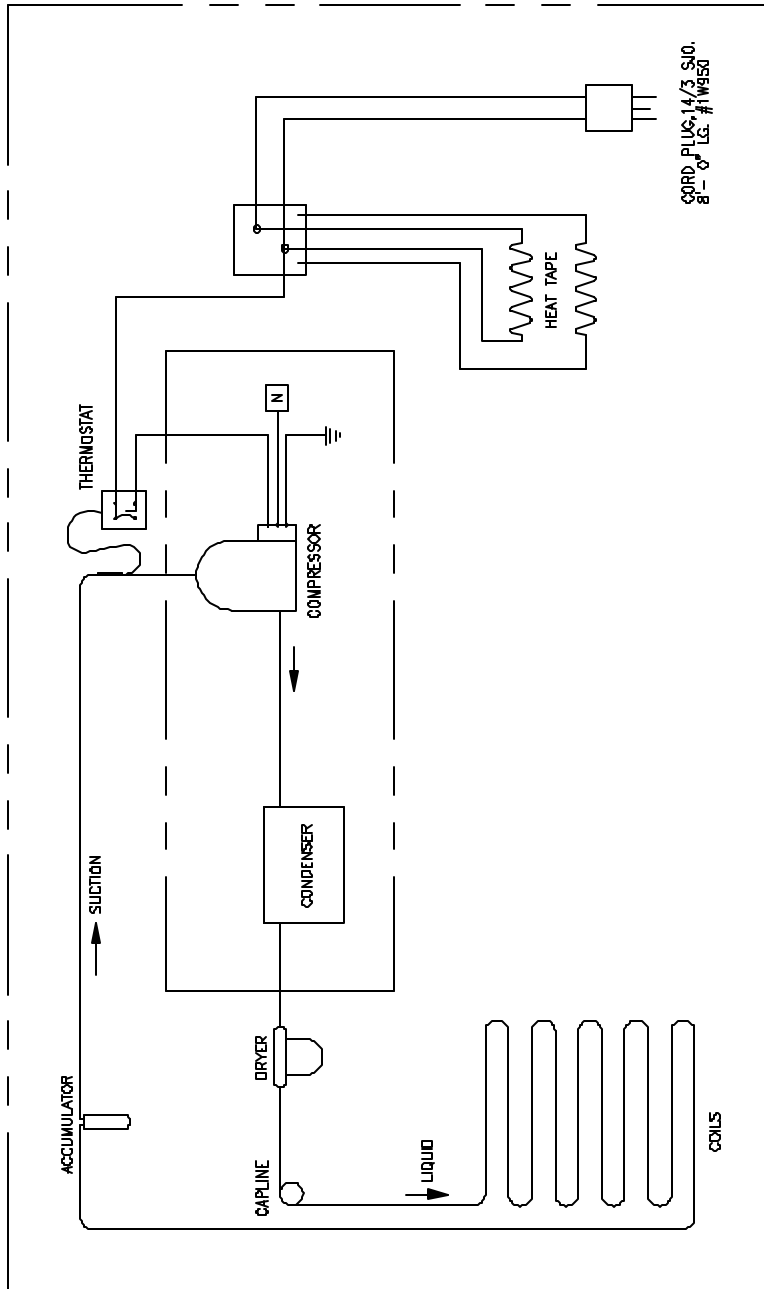

NOTES:

- A. ALL WIRING SHALL BE 14 AWG TYPE THHN-THWN-AWM, RATED 600V, 105 C.
- B. ALL WIRING SHALL CONFORM TO THE NATIONAL AND CANADIAN ELECTRIC CODE.
- C. FREEZER TEMPERATURE SHALL MAINTAIN -10° TO 0° F.
- D. MILLION HEATER UL/CSA LISTED HEAT TECH, INC., 84" LS. DOUBLE SERIES HEATER CABLE RATED AT 115 VOLT, 3.0 WATT PER FOOT, W/2-48' LEADS
 HETAR TAPE LEADS:
 PRIMARY CIRCUIT - BLACK AND WHITE
 SECONDARY CIRCUIT - BLUE AND YELLOW
 (GAP OFF SECONDARY LEADS)
- E. EVAPORATOR - 3/8" O.D. COPPER TUBING, COIL WALL CONSTRUCTION, APPROXIMATELY 360' LONG.
- F. CONDENSING UNIT IS UL LISTED - RATED AT 1/3 HP., 115 VOLT, 60HZ, 1PH, 404A REFRIGERANT.

ITEM	PART NO.	QTY	DESCRIPTION
10	E-2-12	1	J- BOX, 2 X 4 X 2
9	E-2-3-1	1	PLATE, 2 X 4 GALV. COVER
8	P-1-207	1	COMPRESSOR, COPELAND #M4T1-0035-BA-204, 1/3 HP.
7	E-5-21	2	HEAT CABLE, DOUBLE, 115V, 84" LG.
6	P-1-53-1200	1	CAP TUBE #114, .050 I.D. X .114 O.D., 120" LONG
5	P-1-23	1	DRYER, SPORLAN, #C-052-S HH
4	P-1-18-6	1	THERMOSTAT, CUTLER-HAMMER, #5330N123D
3	E-1-50	1	ACCUMULATOR, SPANCO #18033-1
2	E-4-15	1	THERMOMETER, F-DEG. #RR100FA-24
1	E-10-12-10	1	COND. 14/3 SJO 8' LG. W/STRAIGHT PLUG

STORE NO:	CUSTOMER: H & K Dallas Inc. DALLAS TEXAS	TITLE: ASSEMBLY,	DATE: 01MAR02	SYM	REVISION	DATE	SCALE: NONE
	ITEM NO: ASSEMBLY TEMPLATE B		DRAWN: EMPLOYEE NAME				CHECKED:
	SHEET: 1 OF 1	THESE DRAWINGS AND SPECIFICATIONS ARE THE PROPERTY OF H&K DALLAS INC. AND SHALL NOT BE REPRODUCED OR COPIED BY ANY OTHER PARTY WITHOUT THE WRITTEN PERMISSION OF H&K.					



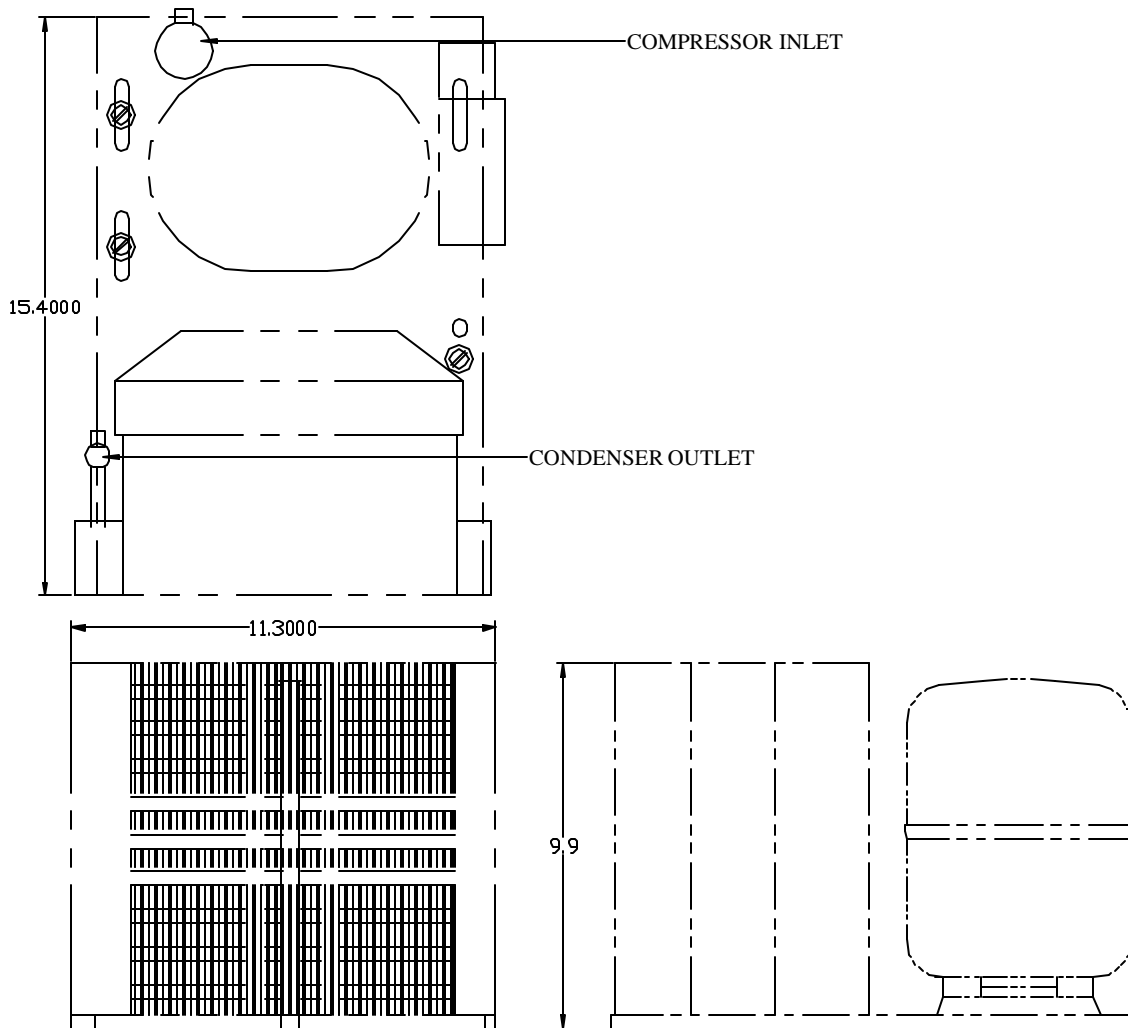

CONDENSING UNIT SPECIFICATIONS

REFRIGERANT	R-404A
CAPACITY @ 90°F AMBIENT	1590 Btuh@-20°F (0.46 kW@-28.8°C)
HORSE POWER	1/3
OVERALL DIMENSIONS (INCHES)	15.4 X 11.3 X 9.9
OPERATING PRESSURES	LSP = 12 PSIG HSP = 240 PSIG
ELECTRICAL DATA	120-1-60 MCA 9.1 MAX. FUSE 15 AMPS
SYSTEM CHARGE	7.5 OZ.



OPTIONS

DESCRIPTION	H&K PART NO.
SELF CLOSING COVER ASSEMBLY	450826
FRAME ASSEMBLY SELF CLOSING COVER	450826.01A
SLIDE COVER	450826.02A
REMOVABLE REAR TOP	450826.03A
WIRE SHELF	PCCAW282
FIXED GLOVE DISPENSER	66051
ADJUSTABLE GLOVE DISPENSER	65537

REPLACEMENT PARTS

DESCRIPTION	H&K PART NO.
CONDENSING UNIT	P-1-207
CAP TUBE	P-1-53-1200
ACCUMULATOR	P-1-50
DRYER	P-1-23
THERMOSTAT	P-1-18-6

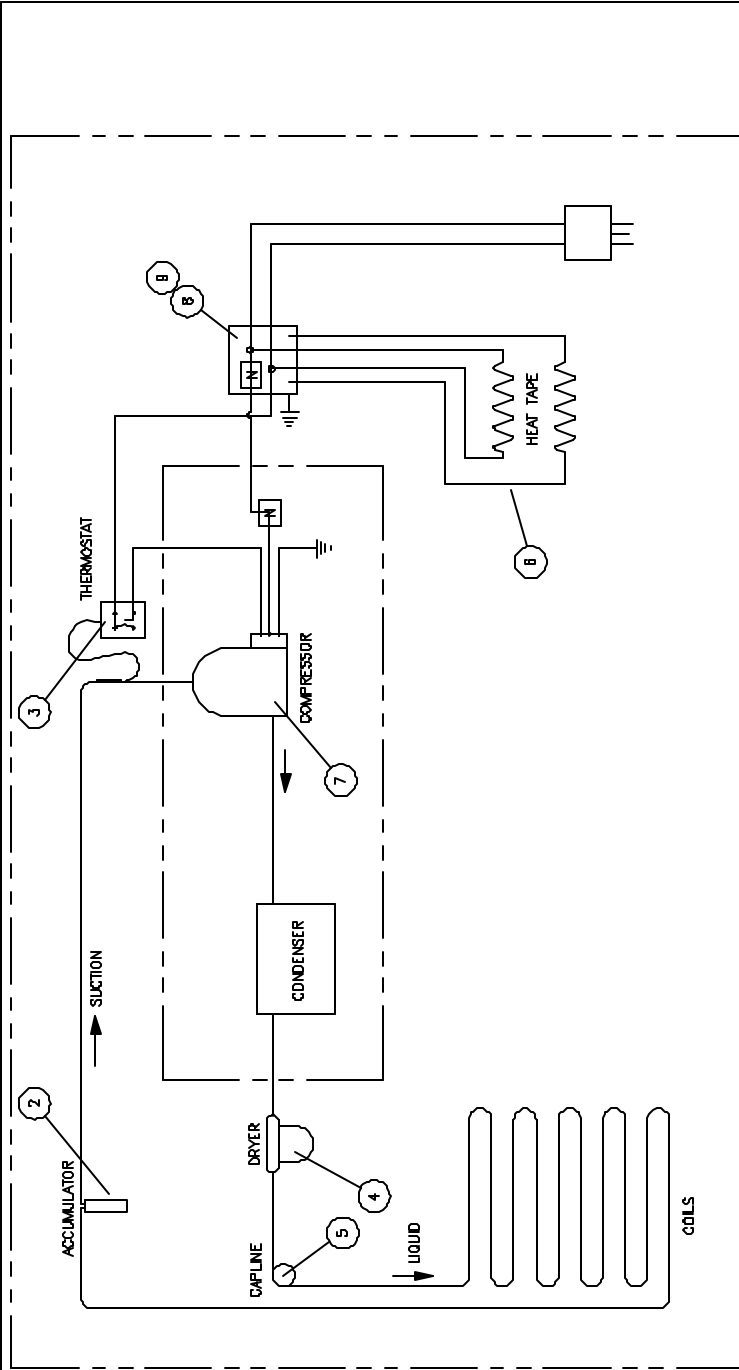

ITEM	PART NO.	QTY	DESCRIPTION
B	E-2-12	1	J- BOX, 2 X 4 X 2
B	E-2-3-1	1	PLATE, 2 X 4 GALV. COVER
7	P-1-2075	1	COMPRESSOR, COPELAND #MAYL003-1A2-3-1 1/3 HP, 220/230 30HZ
6	E-6-215	1	HEAT CABLE, DOUBLE, 220V, 84" LG
3	P-1-53-120D	1	CAP. TUBE #114, 0.5D, I.D. X .114 O.D., 108" LONG
4	P-1-23	1	DRYER, SIFOLAN, FC-052-S, HH
3	P-1-18-B	1	THERMOSTAT, CUTLER-HAMMER, #PSS01120
2	P-1-150	1	ACCUMULATOR, SPINCOZ # 118033-1
1	E-4-15	1	THERMOMETER, F-DEG. #RR105FA-24

- NOTES:
- A. ALL WIRING SHALL BE 14 AWG TYPE THIN-TWIN-AWM, RATED 900V, 105 C.
 - B. ALL WIRING SHALL CONFORM TO THE NATIONAL AND CANADIAN ELECTRIC CODE.
 - C. FREEZER TEMPERATURE SHALL MAINTAIN -40° TO 0° F.
 - D. MILLION HEATER UL/USA LISTED "HEAT TECH", INC., 84" LG. DOUBLE SERIES HEATER CABLE RATED AT 220 VOLT, 3.0 WATT PER FOOT, W/2-48" LEADS HEATER TAPE LEADS: PRIMARY CIRCUIT - BLACK AND WHITE SECONDARY CIRCUIT - BLUE AND YELLOW (CAPUOT SECONDARY LEADS) EVAPORATOR - 3/8" O.D. COPPER TUBING, COLD WALL CONSTRUCTION, APPROXIMATELY 360" LONG. CONDENSING UNIT IS UL LISTED - RATED AT 1/3 HP., 220 VOLT, 50HZ, 1PH, 404A REFRIGERANT.

CUSTOMER: McDONALD'S CORPORATION	TITLE: SCHEMATIC, SINGLE MOBILE MEAT FREEZER 220V/50HZ INTERNATIONAL	DATE: 14FEB96	SWN	REVISION	DATE	SCALE: NONE
DRAWN: M. ROWLAND	CHECKED:					
SHEET: 1 OF 1	THESE DRAWINGS AND SPECIFICATIONS ARE THE PROPERTY OF H&K AND SHALL NOT BE REPRODUCED OR COPIED OR TRANSMITTED IN ANY FORM WITHOUT THE WRITTEN PERMISSION OF H&K.					