

SECTION 3. PARTS INFORMATION

3-1. INTRODUCTION

This section lists the replaceable parts of the Henny Penny HCD-930/932 CDT and HCD-930/932 units.

3-2. GENUINE PARTS

Use only genuine Henny Penny parts in your cabinet. Using a part of lesser quality or substitute design may result in damage to the unit, or personal injury.

3-3. WHEN ORDERING PARTS

Once the parts that you want to order have been found in the parts list, write down the following information:

(Sample)
Item Number 4
Part Number 16684
Description Cooling Fan - 120 V

From data plate, list the following information:

(Sample)
Product Number HCD930.0
Serial Number AW001IE
Voltage 120 Volt

3-4. PRICES

Your distributor has a price list and will be glad to inform you of the cost of your parts order.

3-5. DELIVERY

Commonly replaced items are stocked by your local distributor and will be sent out when your order is received. Other parts will be ordered, by your distributor, from Henny Penny Corporation.

3-6. WARRANTY

All replacement parts (except lamps and fuses) are warranted for 90 days against manufacturing defects and workmanship. If damage occurs during shipping, notify the carrier at once so that a claim may be properly filed. Refer to warranty in the front of the manual for other rights and limitations.

3.7. RECOMMENDED SPARE PARTS FOR DISTRIBUTORS

Recommended replacement parts, stocked by your distributor, are indicated with √ in the parts lists. Please use care when ordering recommended parts, because all voltages and variations are marked. Distributors should order parts based upon common voltages and equipment sold in their territory.

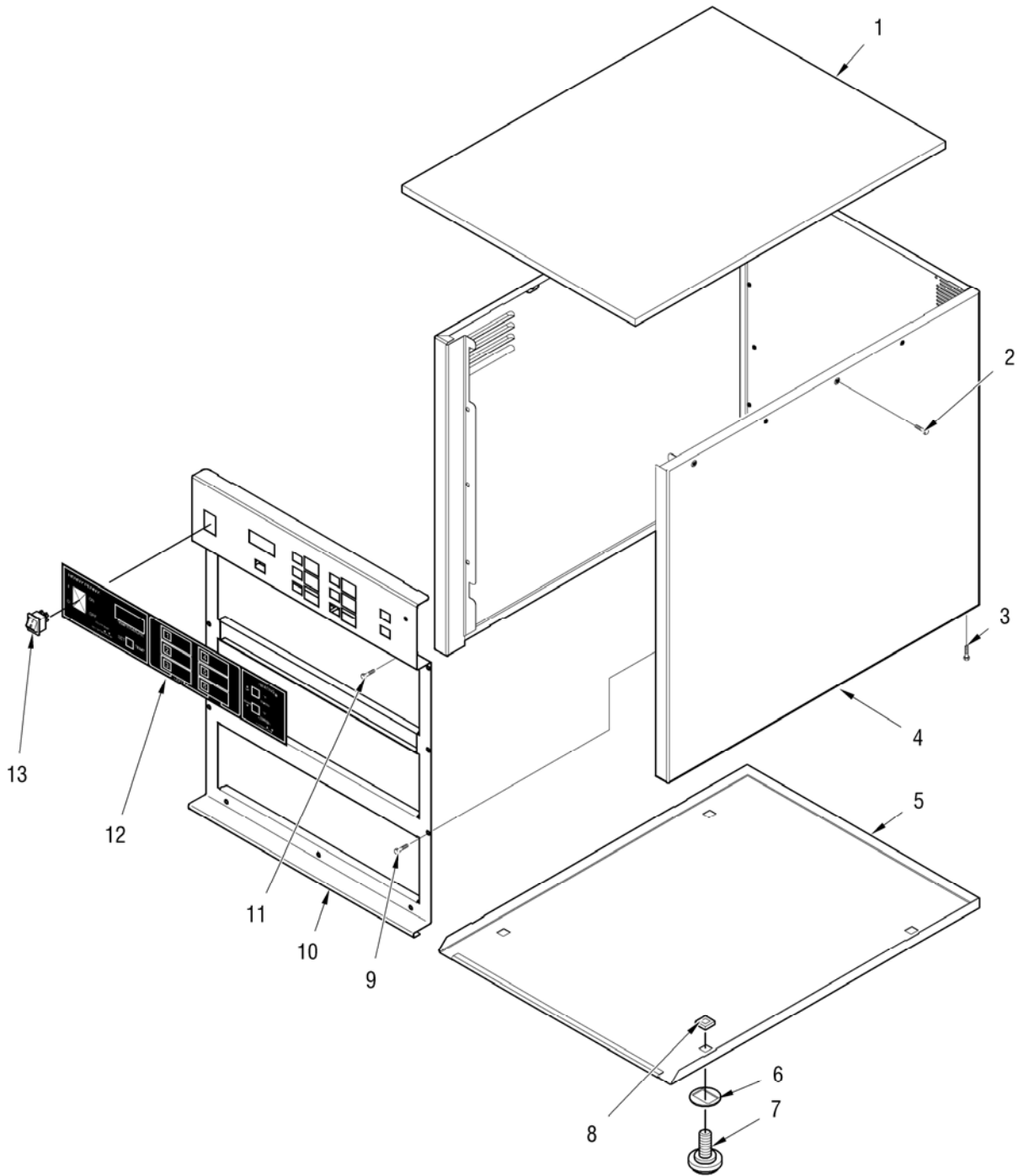

Figure 3-1. Exterior Panels

FIG. & ITEM NO.	PART NO.	DESCRIPTION	QTY.		
			932	930	
3-1		EXTERIOR PANELS			
1	31927	CABINET TOP	1	1	
2	SC02-041	SCREW	4	4	
3	SC02-041	SCREW	6	6	
4	63805	CAB. ENCL. - 930/240V-934 - SN: EA0505003 & BELOW	-	1	
4	69989	CAB. ENCL. - 930/240V-934 - SN: EA0505004 & ABOVE	-	1	
4	53821	CAB. ENCL. - CE - 930/934 - SN: EA0505003 & BELOW	-	1	
4	69990	CAB. ENCL. - CE - 930/934 - SN: EA0505004 & ABOVE	-	1	
4	53843	CABINET ENCLOSURE - 930DQ/120V-934	-	1	
4	53954	CABINET ENCLOSURE - 930Q-SN: EA0505003 & BELOW	-	1	
4	69993	CABINET ENCLOSURE - 930Q-SN: EA0505004 & ABOVE	-	1	
4	63804	CAB. ENCL. - 932 - SN: EA0505003 & BELOW	1	-	
4	69969	CAB. ENCL. - 932 - SN: EA0505004 & ABOVE	1	-	
4	53961	CAB. ENCL. - 932 - CE- SN: EA0505003 & BELOW	1	-	
4	69967	CAB. ENCL. - 932 - CE- SN: EA0505004 & ABOVE	1	-	
4	54056	CABINET ENCLOSURE - 932DQ/240V-MCDS-932	1	-	
5	41773	BASE ASSEMBLY	1	1	
6	15022	SPACER	4	4	
7	26411	LEVELER FOOT	4	4	
8	NS03-013	CAGE NUT	4	4	
9	SC02-016	SCREW	5	7	
10	37174	PANEL - FACE PLATE	-	1	
10	63854	PANEL - FACE PLATE - CE	-	1	
10	31576	PANEL - FACE PLATE - MCD	-	1	
10	58188	PANEL - FACE PLATE - KFC	-	1	
10	44671	PANEL - FACE PLATE - 932 - E/M	1	-	
10	63855	PANEL - FACE PLATE - 932 - E/M - CE	1	-	
10	41765	PANEL - FACE PLATE - 932 - CDT	1	-	
10	63852	PANEL - FACE PLATE - 932 -CDT - CE	1	-	
10	44670	PANEL - FACE PLATE - 930 - E/M	-	1	
10	63856	PANEL - FACE PLATE - 930 - E/M - CE	-	1	
10	44712	PANEL - FACE PLATE - 932 - DQ	1	-	
11	SC03-004	SCREW	3	3	
12	61747	CONTROL DECAL - 930 CDT	-	1	
12	61728	CONTROL DECAL - 932 CDT	1	-	
12	41695	CONTROL DECAL - 932 - MCDONALDS	1	-	
12	37377	CONTROL DECAL - 934 - MCD	-	1	
12	61001	CONTROL DECAL - KFC	-	1	
12	61727	CONTROL DECAL - 930 E/M	-	1	
12	61729	CONTROL DECAL - 932 E/M	1	-	
12	48633	CONTROL DECAL - 930 - DQ	-	1	
12	48632	CONTROL DECAL - 932 - DQ	1	-	
12	48043	CONTROL DECAL - 930Q	-	1	
√	13	72277	SWITCH - POWER DPST SPLASH PROOF	1	1
√	13	52224	ROCKER SWITCH - CE - 125-250V	1	1
	14*	15063	POWER CORD - 120 VOLT	1	1
	14*	70436	POWER CORD - CE	1	1

√ recommended parts

*not shown

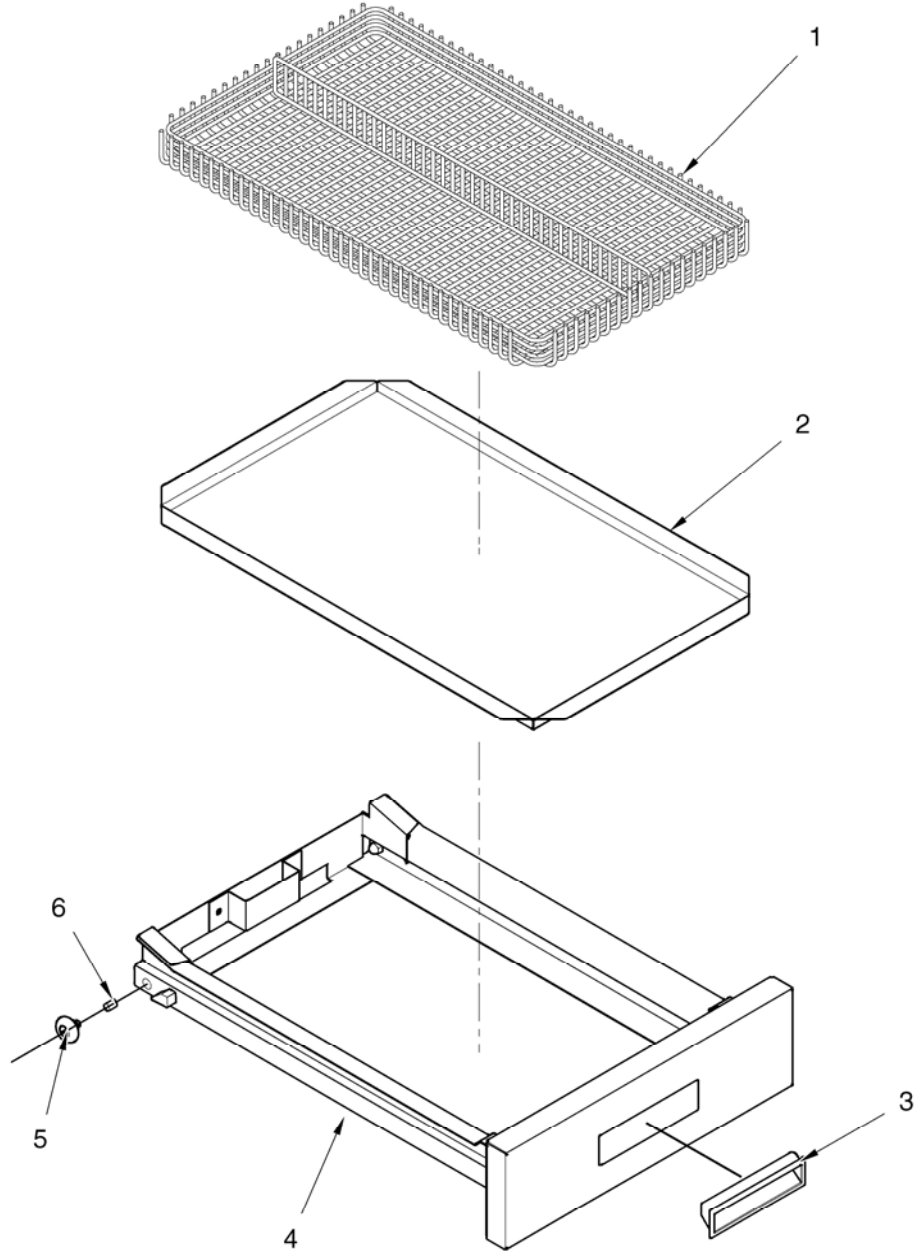

Figure 3-2. Drawer

FIG. & NO.	PART NO.	DESCRIPTION	QTY	
			932	930
3-2		DRAWER		
1	31504	WIRE BASKET W/DIVIDER	2	3
2	31417	CRUMB TRAYS	2	3
3	41836	DRAWER HANDLE	2	3
4	44374	DRAWER ASSEMBLY COMPLETE	2	3
4	44373	DRAWER FRAME WELD ASSY.	2	3
4	49525	DRAWER ASSEMBLY COMPLETE-QUICK	-	3
4	49521	DRAWER FRAME WELD ASSY-QUICK	-	3
5	31421	BEARING W/SCREW	4	6
6	31357	BEARING SPACER	4	6

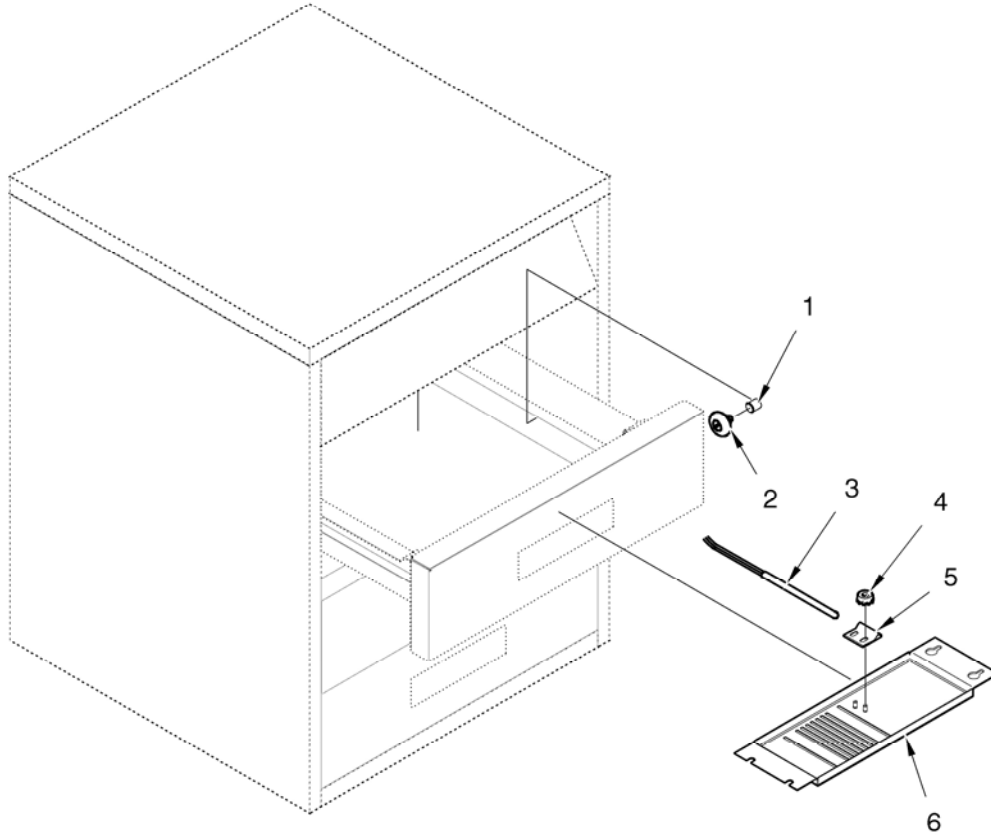

Figure 3-3. Probe

FIG. & ITEM NO.	PART NO.	DESCRIPTION	QTY.
3-3		PROBE	
1	31357	BEARING SPACER	6
2	31421	BEARING W/SCREW	6
√ 3	29523	PROBE	1
4	NS02-005	NUT	2
5	31483	PROBE BRACKET	1
6	48107	PROBE COVER	1

√ recommended parts

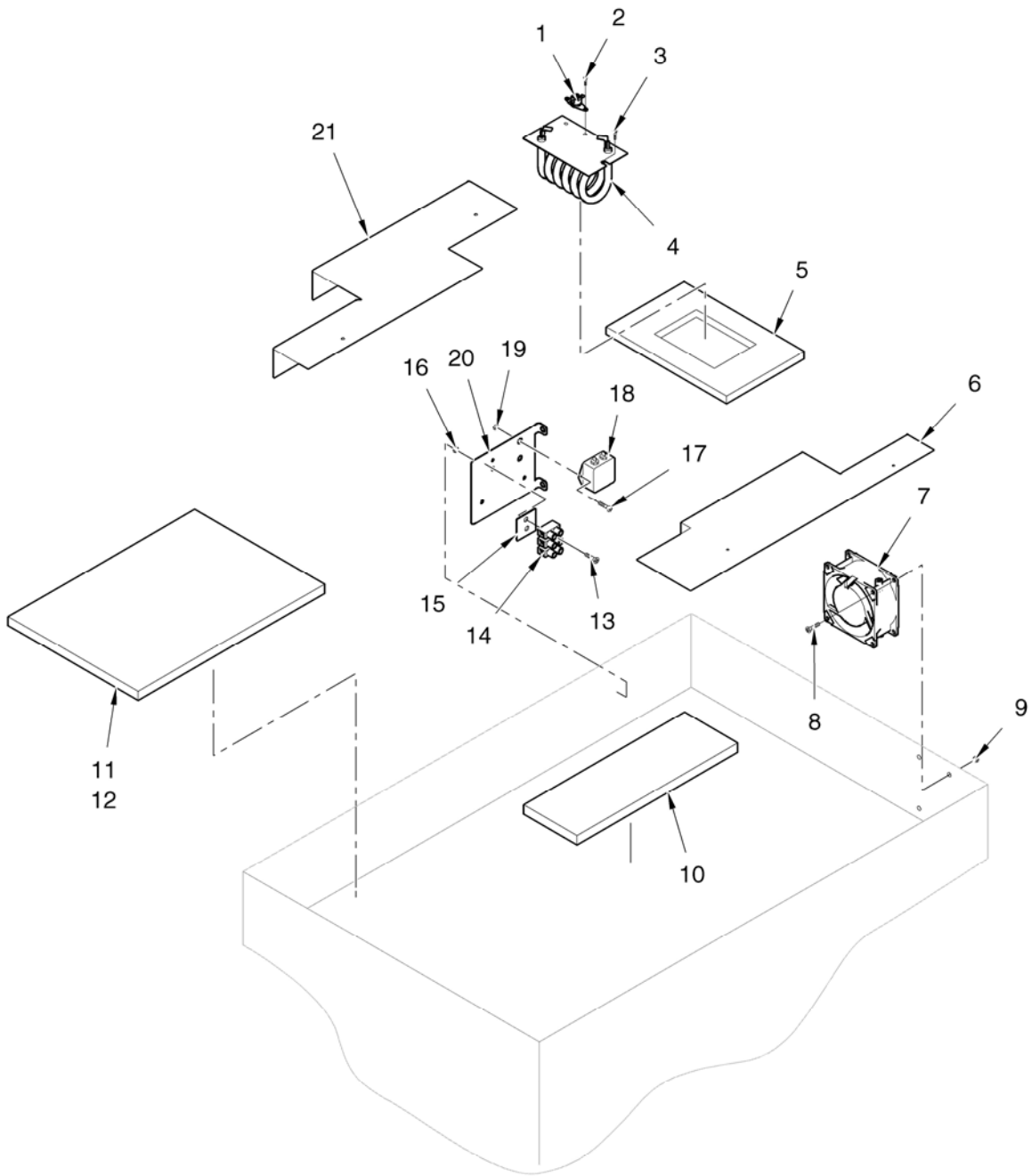

Figure 3-4. Heaters and Insulation

FIG. & ITEM NO.	PART NO.	DESCRIPTION	QTY.
3-4		HEATERS AND INSULATION	
√ 1	27071	HIGH LIMIT - E/M	1
√ 1	65132	HIGH LIMIT - 415° CE	1
2	SC04-003	SCREW	2
3	SC04-003	SCREW	2
√ 4	27661	HEATER - 120V-800W; DOMESTIC CDT	1
√ 4	27943	HEATER - 240V-800W; INTERNATIONAL E/M & CDT	1
√ 4	44529	HEATER - 120V-800W; DOMESTIC E/M	1
√ 4	44975	HEATER-240V-1000W; 930Q	1
5	44966	INSULATION - TOP	1
6	44971	RETAINER - RIGHT INSULATION	1
√ 7	16684	COOLING FAN - 120V	1
√ 7	16688	COOLING FAN - 240V	1
8	SC01-037	SCREW	4
9	NS02-005	NUT	4
10	44969	INSULATION	1
11	44968	INSULATION	2
12	44965	INSULATION	1
13	SC01-176	SCREW	2
14	31563	TERMINAL BLOCK ASSY	1
14	ME50-021	TERMINAL BLOCK ASSY - CE	1
15	44854	INSULATOR	1
16	NS02-009	NUT	2
17	SC01-023	SCREW	2
18	52080	POWER CORD FILTER-CE	1
19	NS02-005	NUT	2
20	40836	MOUNTING BRACKET, TERMINAL BLOCK & RELAY	1
20	46811	TERMINAL & NUTSERT BRACKET ASSY. - CE	1
21	44973	RETAINER - LEFT INSULATION	1
22*	31549	INSULATION - WRAP-AROUND	1
23*	SC01-134	SCREW	2
24*	NS02-007	NUT	2

√ recommended parts
 *not shown

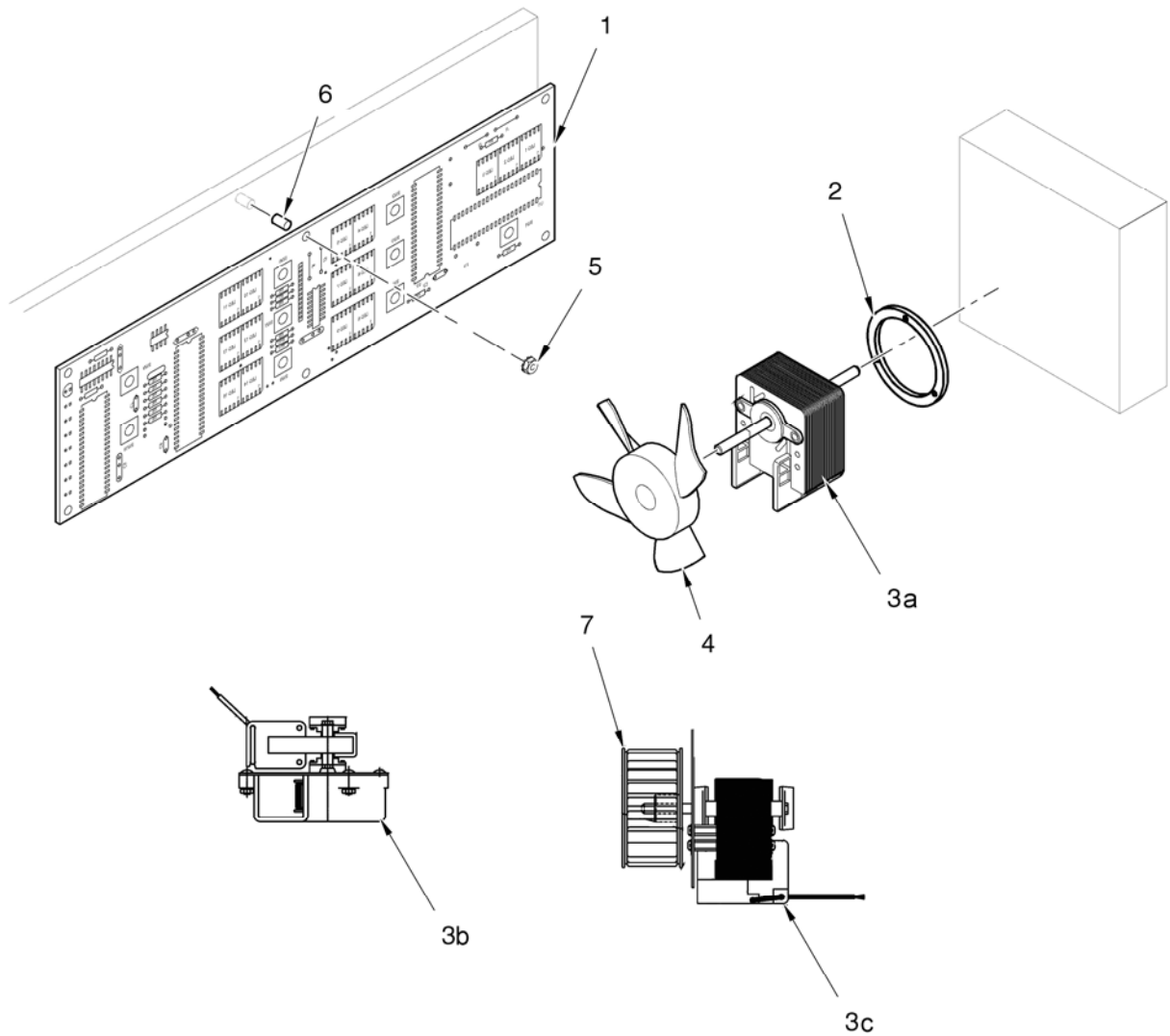

Figure 3-5. Display PCB and Blower Motor

FIG. & ITEM NO.	PART NO.	DESCRIPTION	QTY.
3-5		DISPLAY PCB AND BLOWER MOTOR	
√ 1	37374RB	6 TIMER DISPLAY PC BOARD – 930 CDT	1
√ 1	41818RB	4 TIMER DISPLAY PC BOARD – 932 CDT	1
2	25698	BLOWER PLATE GASKET	1
√ 3a	25751	BLOWER MOTOR - 120V	1
√ 3a	25752	BLOWER MOTOR - 240V	1
√ 3b	25221	BLOWER MOTOR - 120V	1
√ 3b	25407	BLOWER MOTOR - 240V – 50HZ	1
√ 3c	31371	BLOWER MOTOR - 120V	1
4	25706	FAN BLADE	1
5	NS02-005	NUT	6
6	31555	SPACER	6
7	25621	WHEEL - BLOWER	1
8*	25619	BLOWER OUTLET GASKET	1

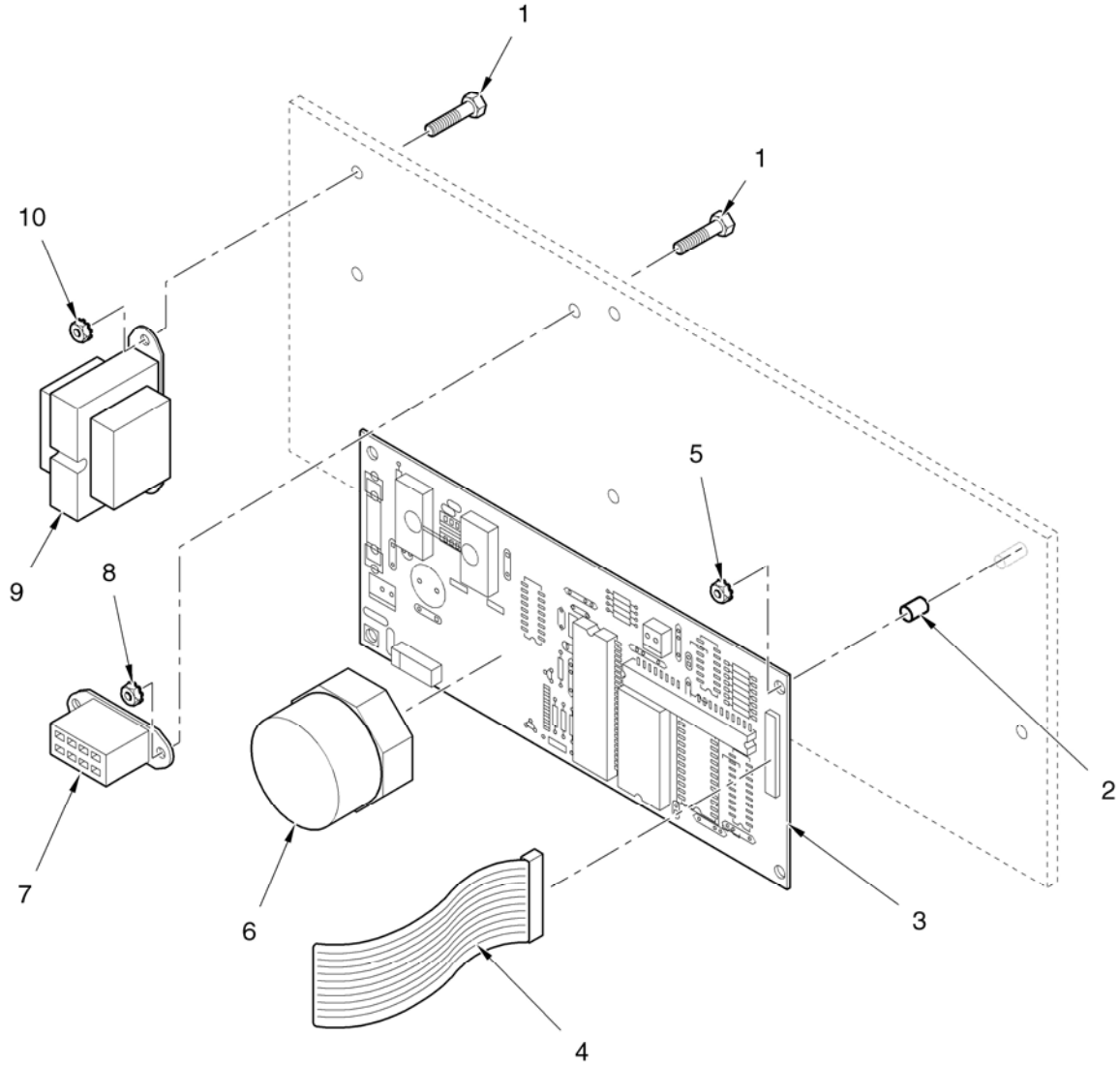

Figure 3-6. Count Down Timer (CDT) Controls

FIG. & ITEM NO.	PART NO.	DESCRIPTION	QTY.
3-6		COUNT DOWN TIMER (CDT) CONTROLS	
1	SC01-049	SCREW	4
2	ME50-014	SPACERS	4
√ 3	70047RB	CONTROL PC BOARD – 930 CDT	1
√ 3	54855RB	CONTROL PC BOARD; KFC	1
√ 3	70048RB	CONTROL PC BOARD; 4 TIMER; MCD	1
√ 3	70114RB	CONTROL PC BOARD - 930 Q	1
4	31737	CONTROL PC BOARD CABLE ASSY	1
5	NS02-005	NUT	4
√ 6	36210	REPLACEABLE BEEPER	1
√ 7	31369	RELAY - 115/240V	1
8	NS02-005	NUT	2
√ 9	30978	TRANSFORMER - 115V	1
√ 9	28979	TRANSFORMER - 240V	1
10	NS02-005	NUT	2

√ recommended parts

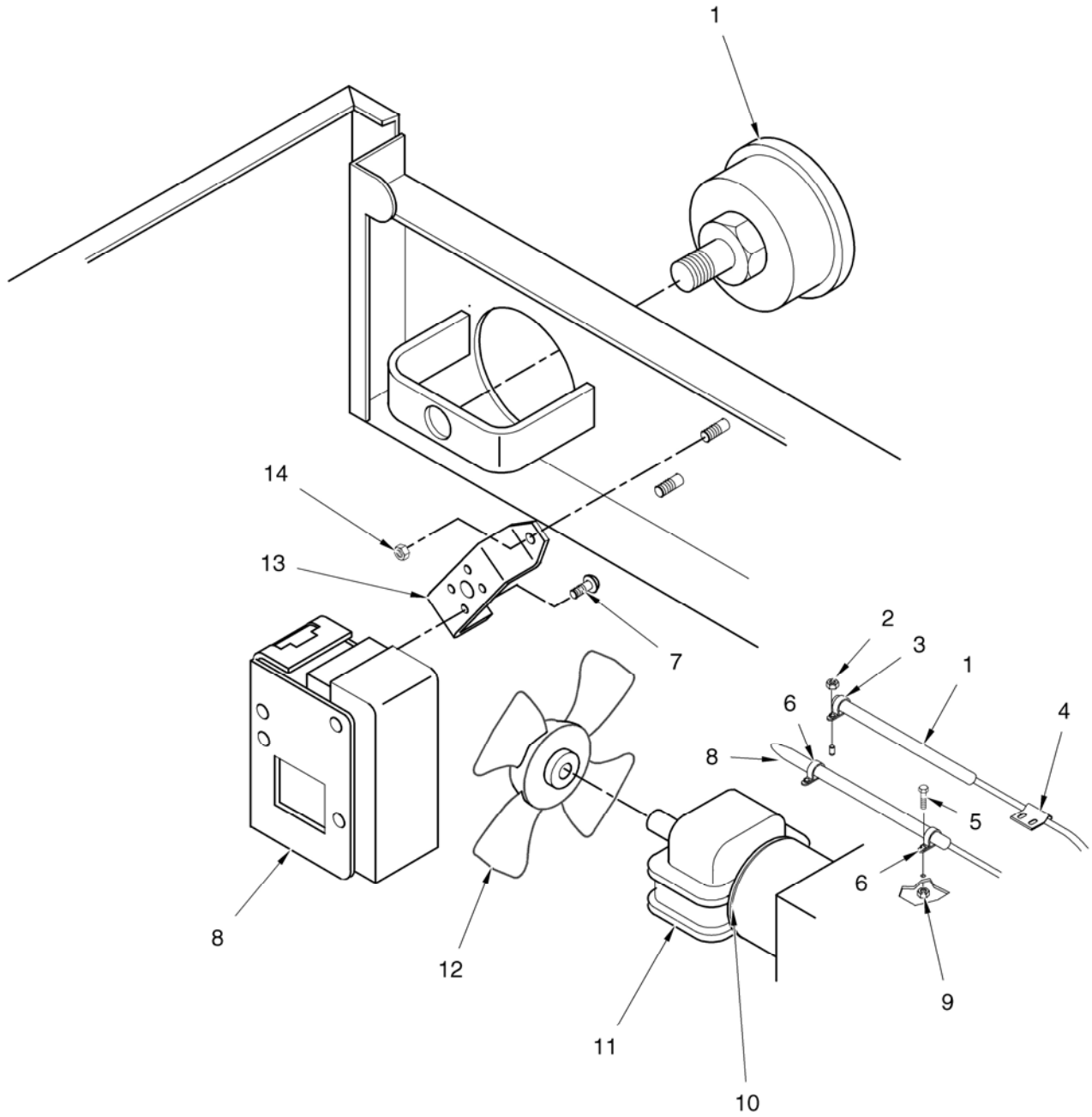

Figure 3-7. Electro-Mechanical Components

FIG. & ITEM NO.	PART NO.	DESCRIPTION	QTY.
3-7		ELECTRO-MECHANICAL (E/M) COMPONENTS	
√ 1	14250	THERMOMETER	1
2	NS02-006	NUT	2
3	EF02-035	CLAMP, THERMOMETER BULB	1
4	EF02-030	CLAMP, THERMOMETER BULB	1
5	SC01-023	SCREW	2
6	EF02-031	CLAMP, THERMOSTAT BULB	2
7	SC01-023	SCREW	2
√ 8	14209	THERMOSTAT WITH CLIPS	1
9	NS02-006	NUT	2
10	25698	BLOWER PLATE GASKET	1
√ 11	25751	BLOWER MOTOR – 120 VOLT	1
√ 11	25752	BLOWER MOTOR – 240 VOLT	1
12	25706	FAN BLADE	1
13	25903	BRACKET, THERMOSTAT	1
14	NS02-006	NUT	2
15*	44923	BLOWER BOX END	1
16*	SC01-034	SCREW	3
17*	NS02-007	NUT	2
18*	25619	BLOWER OUTLET GASKET	1

√ recommended parts

*not shown

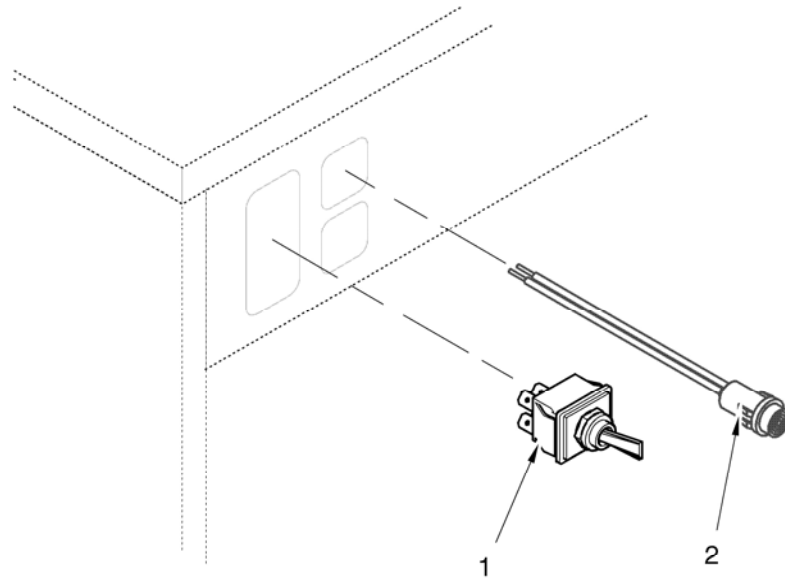

Figure 3-8. Electro-Mechanical (E/M) Controls

FIG. & ITEM NO.	PART NO.	DESCRIPTION	QTY.
3-8		ELECTRO-MECHANICAL (E/M) CONTROLS	
√ 1	49353	TOGGLE SWITCH	1
√ 2	16624	INDICATOR LIGHTS	2
√ 2	54085	INDICATOR LIGHT, GREEN - CE	2

√ recommended parts