



Responsive, Reliable Solutions

# INFERNO 4500

Gas-Fired, Self-Cleaning Rotisserie for GB

## Operation Manual



Hardt Equipment Manufacturing Inc.  
1400 50<sup>th</sup> Avenue, Lachine (Montreal)  
Quebec, Canada, H8T 2V3

**Technical Support**

Tel: (514) 631-7271

Fax: (514) 631-5443

**Sales**

Tel: (514) 631-7271

[www.hardtequipment.com](http://www.hardtequipment.com)

This manual is to be left with the customer for future reference.

## 1. Important Information

### **FOR YOUR SAFETY**

**Do not store or use gasoline or other flammable vapors or liquids in the vicinity of this or any other appliance.**

### **WARNING**

**Improper installation, adjustment, alteration, service or maintenance can cause property damage, injury or death. Read the installation, operating and maintenance instructions thoroughly before installing or servicing this equipment.**

### **IMPORTANT**

**You must post in a prominent location, instructions to be followed in the event the user smells gas. Specific instructions can be obtained from your local gas supplier.**

### **IMPORTANT**

**These instructions are only valid if the country code appears on the appliance. If the code does not appear on the appliance, refer to the technical instructions for adapting the appliance to the conditions for use in that country.**

# Contents

<b>1. Important Information</b> .....	<b>2</b>
<b>2. Safety</b> .....	<b>4</b>
2.1. About This Manual .....	4
2.2. Equipment Safety .....	4
2.3. Food Safety .....	5
<b>3. Equipment Diagrams</b> .....	<b>6</b>
3.1. Single Unit .....	6
3.2. Double Deck Unit .....	7
3.3. Marking Locations .....	8
3.4. Control Panel Layout .....	9
<b>4. Operation</b> .....	<b>10</b>
4.1. Morning Startup .....	10
4.1.1. Starting the Rotisserie .....	10
4.1.2. Grease Collection .....	11
4.2. Cooking Procedure .....	12
4.3. Loading & Unloading the Rotisserie .....	13
4.3.1. Loading the Skewers .....	13
4.3.2. Unloading the Skewers .....	13
4.4. Controller Functions .....	14
4.4.1. Buzzers and Alarms .....	14
4.4.2. Programming .....	14
<b>5. Maintenance</b> .....	<b>15</b>
5.1. Daily Cleaning .....	15
5.1.1. Beginning of the Day .....	15
5.1.2. Cleaning Throughout the Day .....	15
5.1.3. Cleaning at the End of the Day: Auto Clean Operation .....	16
5.1.4. Auto Clean Effectiveness Evaluation .....	17
5.2. Weekly Inspection .....	18
5.3. Flame Shields .....	18
5.4. Material Cleaning Guidelines .....	19
5.4.1. Guidelines for Cleaning Glass Surfaces .....	19
5.4.2. Guidelines for Cleaning Metal Surfaces .....	19
<b>6. Troubleshooting</b> .....	<b>20</b>
6.1. Rotisserie Does Not Operate .....	20
6.2. Safety Lockout .....	20
6.3. Replacing the Halogen Lamp .....	21
<b>7. Accessories &amp; Parts</b> .....	<b>21</b>
7.1. Replacement Parts .....	21

## 2. Safety

### 2.1. About This Manual

This manual contains information necessary for the operation of the HARDT Equipment Manufacturing (hereafter referred to as Hardt) Inferno 4500 rotisserie. Retain this manual for future reference. To help the reader in the utilization of this manual, certain information has been highlighted using the following conventions:



**INFORMATION THAT REFERS TO ACTIONS WHICH MAY HAVE CONSEQUENCES POTENTIALLY DANGEROUS TO THE OPERATOR AND/OR THE EQUIPMENT.**



**Information for proper installation and functioning.**



Additional important information.

### 2.2. Equipment Safety



**THERE ARE SOME SAFETY CONSIDERATIONS TO TAKE INTO ACCOUNT WHEN OPERATING THIS EQUIPMENT. IT IS VERY IMPORTANT THAT YOU FULLY UNDERSTAND THIS DOCUMENT AND THE SAFETY PRECAUTIONS WRITTEN HERE.**

- Read all documentation; only people who have read and understand the documentation should use the equipment.
- Do not use this equipment for anything other than its intended use.
- Do not operate this equipment if it is damaged in any way.
- Do not use unauthorized accessories.
- Do not operate this equipment near flammable materials.
- Always check for gas leaks; vacate the area and call the gas supply company if any are detected.
- Clean the equipment every day; build-up of waste in the rotisserie can cause fires.
- When the unit is plugged in, there are potentially dangerous voltages present in the control circuits; do not open the electrical compartment as there are potentially lethal voltages present.
- Do not cover any vents.
- Always check for water leaks; do not operate if leaks are visible.
- Do not immerse the cord or plug in water.
- Use only approved detergents.
- Keep hair and loose clothing away from any moving parts.
- Do not work with any hot surfaces without wearing protective gloves and an apron.
- Keep the area around the rotisserie clear of combustibles. Combustible material must not come closer than 5 cm (2") to the front of the unit.
- Any equipment that burns gas carries a risk of producing carbon monoxide; if headaches, dizziness, shortness of breath, nausea, vomiting or confusion are encountered, shut down all equipment and vacate the area. Have the equipment inspected immediately.



**Contact Hardt or an approved service provider immediately if any problems are encountered with your equipment.**



**FAILURE TO FOLLOW THESE SAFETY PRECAUTIONS CAN RESULT IN INJURY, DEATH AND/OR PROPERTY DAMAGE.**



**This appliance is equipped with a restraint cable. In the event the cable is disconnected for inspection or cleaning, ensure that it is reconnected before you operate the rotisserie. Do not modify any components unless specifically instructed to do so by the manufacturer or its agents. A qualified installer should be called in to install the rotisserie and if necessary to convert it for use with other gasses.**

**If a gas conversion is required, contact HARDT to order the appropriate conversion kit. You will need to provide the serial number of the oven along with the country and gas type to which the oven will be converted.**

## 2.3. Food Safety



**THERE ARE PRECAUTIONS THAT NEED TO BE TAKEN WHEN WORKING WITH RAW MEATS. FAILURE TO FOLLOW PROPER FOOD PREPARATION PROCEDURES CAN RESULT IN ILLNESS AND DEATH.**

**SOME PRECAUTIONS ARE LISTED IN THIS DOCUMENT BUT YOU SHOULD NOT RELY SOLELY ON THIS DOCUMENT FOR FOOD SAFE PROCEDURES.**

**IT IS RECOMMENDED THAT ONLY PERSONS WHO ARE FULLY TRAINED IN FOOD SAFETY SHOULD PREPARE FOOD ITEMS.**

- Wash all surfaces and equipment that comes into contact with raw meat or its juices.
- Always thoroughly wash your hands after working with raw meat.
- Do not allow raw meat or its juices to contact cooked meat.
- Use separate utensils for working with raw and cooked meat.
- Use separate containers/trays for holding raw and cooked meat.
- Always use a clean food thermometer to ensure meat is at a safe temperature before removing from the rotisserie.

The table below describes how long each type of meat must be at a specific temperature to ensure that all bacteria are killed. Always use a calibrated food thermometer to ensure that your product reaches these temperatures for the specified time period before considering it safe for consumption.

Table 1

<b>Safe Cooking Times and Temperatures*</b>	
<b>Product</b>	<b>Temperature/Time</b>
Poultry (whole or ground duck, chicken or turkey)	74°C (165°F) for 15 seconds
Stuffing and stuffed meat, fish, poultry and pasta	74°C (165°F) for 15 seconds
Ground meat (beef, pork, and other meat)	68°C (155°F) for 15 seconds
Injected meat (brined ham and flavor injected roasts)	68°C (155°F) for 15 seconds
Pork, beef, veal, lamb, steaks/chops	63°C (145°F) for 15 seconds
Roast	63°C (145°F) for 4 minutes
Seafood (fish, shellfish, crustaceans)	63°C (145°F) for 15 seconds
Commercially processed ready-to-eat food	57°C (135°F) (Hot held for service)

\*National Restaurant Association, *ServSafe Course book*, Fifth Edition, New Jersey, Prentice Hall, 2008.



The values listed in this table are industry standard minimum temperatures to ensure food is safely cooked, and may not represent the temperatures dictated by your company.



**COOKING ANY NEW PRODUCT OR ANY CURRENT PRODUCT PREPARED IN A DIFFERENT WAY REQUIRES A VALIDATION OF COOKING TIMES AND COOKING TEMPERATURES BY MEASUREMENT OF INTERNAL PRODUCT TEMPERATURES.**

**DO NOT ASSUME SAFE COOKING PARAMETERS EXIST WITHOUT PERFORMING FOOD-SPECIFIC TESTS. ALWAYS MEASURE THE INTERNAL TEMPERATURE OF A PRODUCT BEFORE ENDING THE COOKING. ACCEPTED INTERNAL TEMPERATURES SHOULD NOT BE LOWER THAN THOSE PUBLISHED FOR ESTABLISHED FOOD SAFETY STANDARDS.**

**CONSULT HARDT IF YOU NEED HELP SETTING UP A FOOD SAFETY PROGRAM.**

## 3. Equipment Diagrams

### 3.1. Single Unit

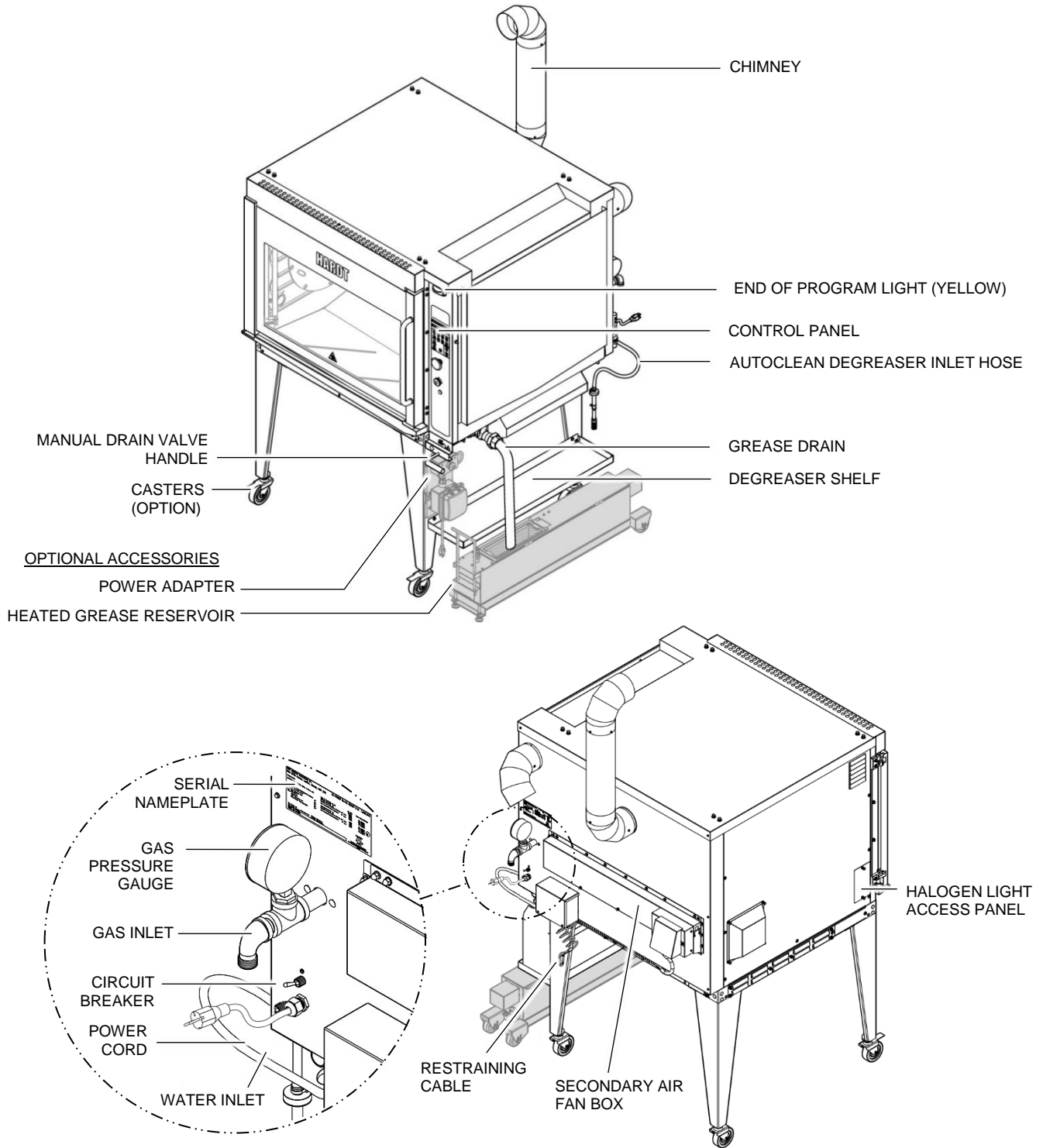

Figure 3-1

For a full list of available accessories, please visit [www.hardtequipment.com](http://www.hardtequipment.com) or contact your sales account representative.

### 3.2. Double Deck Unit

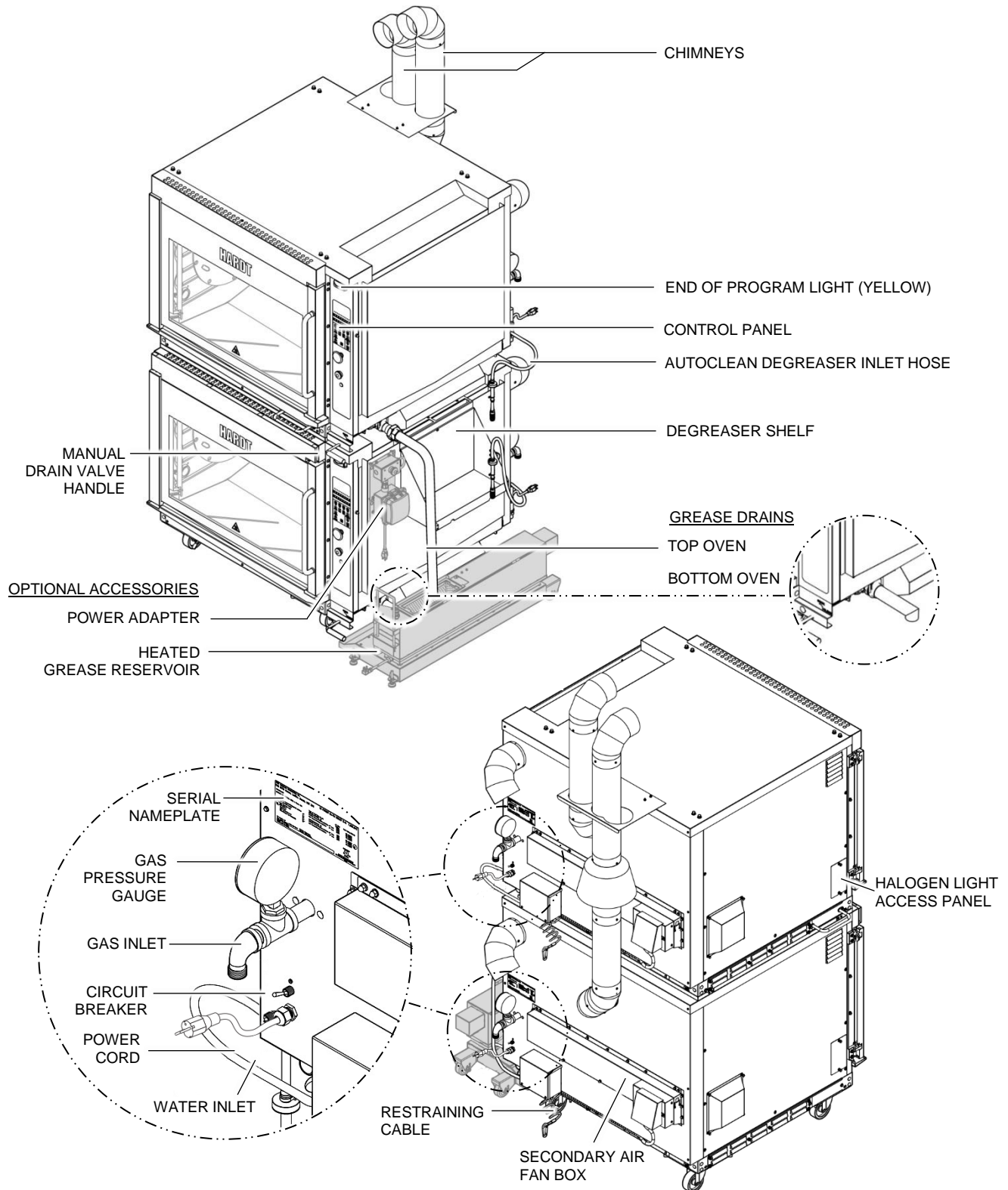

Figure 3-2

For a full list of available accessories, please visit [www.hardtequipment.com](http://www.hardtequipment.com) or contact your sales account representative.

### 3.3. Marking Locations

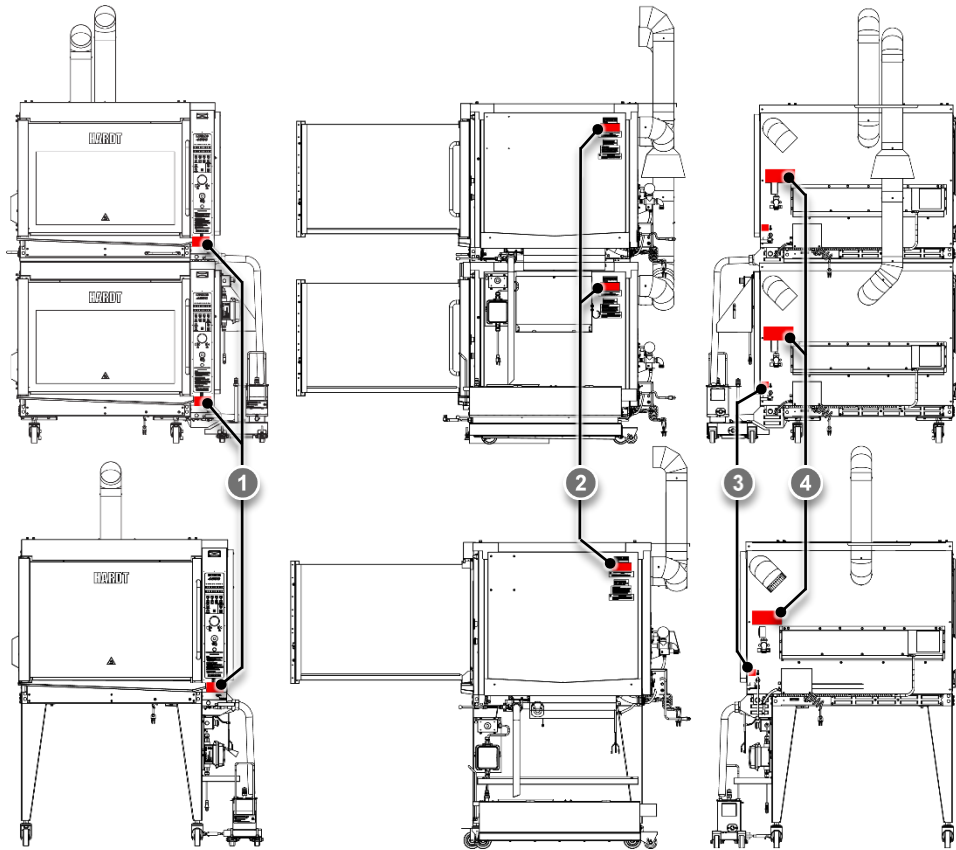

Figure 3-3

#### 1) Supervision Warning Decal (99-7635)

This appliance is not intended for use by persons (including children) with reduced physical, sensory or mental capabilities, or lack of experience and knowledge, unless they have been given supervision or instruction concerning the use of the appliance by a person responsible for their safety. Children should be supervised to ensure that they do not play with the appliance.

Cet appareil n'est pas destiné à être utilisé par des personnes (y compris les enfants) dont les capacités physiques, sensorielles ou mentales sont réduites ou le manque d'expérience et de connaissance à moins qu'ils soient sous surveillance ou qu'ils aient reçu des instructions concernant l'utilisation de l'appareil par une personne responsable de leur sécurité. Les enfants doivent être surveillés pour s'assurer qu'ils ne jouent pas avec l'appareil.

Este aparato no está diseñado para ser utilizado por personas (incluidos niños) con capacidades físicas, sensoriales o mentales reducidas, o falta de experiencia y conocimiento, a menos que sean supervisados o instruidos acerca del uso del aparato por una persona responsable de su seguridad. Los niños deben ser supervisados para asegurarse de que no jueguen con el aparato.

99-7635

#### 2) Ventilation Warning (99-7638)

This appliance shall be installed in conformity with the current regulations and used only in a well ventilated location. Consult the instructions before installing and using this appliance.

Cet appareil doit être installé en conformité avec les règlements en vigueur et doit être utilisé uniquement dans un endroit bien ventilé. Consulter les instructions avant d'installer et d'utiliser cet appareil.

Este aparato debe ser instalado de conformidad con la normativa vigente y se utiliza sólo en un lugar bien ventilado. Consulte las instrucciones antes de instalar y de usar este aparato.

#### 3) On/Off Marking (99-7636)

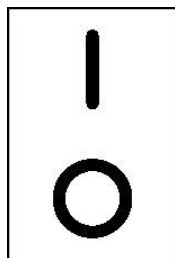

#### 4) Nameplate (99-17959)

**HARDT Equipment Manufacturing Inc.** US Patent No./ N<sup>o</sup>. Brevet É.U./ n<sup>o</sup>. Patente EE.UU.: 7,060,942  
1400 50<sup>th</sup> Avenue, Lachine, Québec, Canada, H8T 2V3  
Model / Modèle / Modelo: Inferno 4500 220 240VAC, 50Hz, 14P<sup>o</sup> 6 AMP

Gas Category / Catégorie de gaz / Gas Categoría	Orifice Size / Taille de l'orifice / Tamaño del orificio	Manifold Pressure - Inlet Pressure / Pression collecteur - Pression admission / Colector de presión - Presión de entrada	Nominal Heat Input / Débit calorifique nominal / Potencia térmica nominal	
13+28-30, 37	G1	3.05 mm	25 mbar - 28-30 mbar	29.74 kW
	G1	3.05 mm	25 mbar - 37 mbar	29.74 kW
13B/P130	G30	3.05mm	25 mbar - 30 mbar	29.74 kW
	G1	3.05 mm	25 mbar - 30 mbar	29.74 kW
12H	G20	4.57 mm	11.2 mbar - 20 mbar	29.59 kW
12E1	G20	4.57 mm	11.2 mbar - 20 mbar	29.59 kW
	G25	4.57 mm	11.2 mbar - 20 mbar	29.59 kW

Water Pressure Range / Plage de pression de l'eau / Rango de presión de agua: 207 kPa - 620 kPa

Minimum Clearance / Déplacement minimum / Distancias mínimas:	For Use In / Pour l'utilisation en / Para uso en:
Left Side/Côté gauche/Lado izquierdo	CB
Right Side/Côté droit/Lado derecho	IE
Rear/Arrière/Trasera	ES
Front/Avant/Frente	FG
Floor/Plancher/Piso	Non-Combustible

Intended for other than household use. / Destiné à un usage autre que domestique. / No para uso doméstico.

Oven Classification / Classification du Four / Clasificación de Hornos: A1

SERIAL No. / N<sup>o</sup>. SÉRIE / n<sup>o</sup>. SERIE: \_\_\_\_\_

99-17959 26V/02

US Patent No. / N<sup>o</sup>. Brevet É.U. / n<sup>o</sup>. Patente EE.UU.: 7,060,942

CE XXXX  
PIN: XXXXXXX

### 3.4. Control Panel Layout

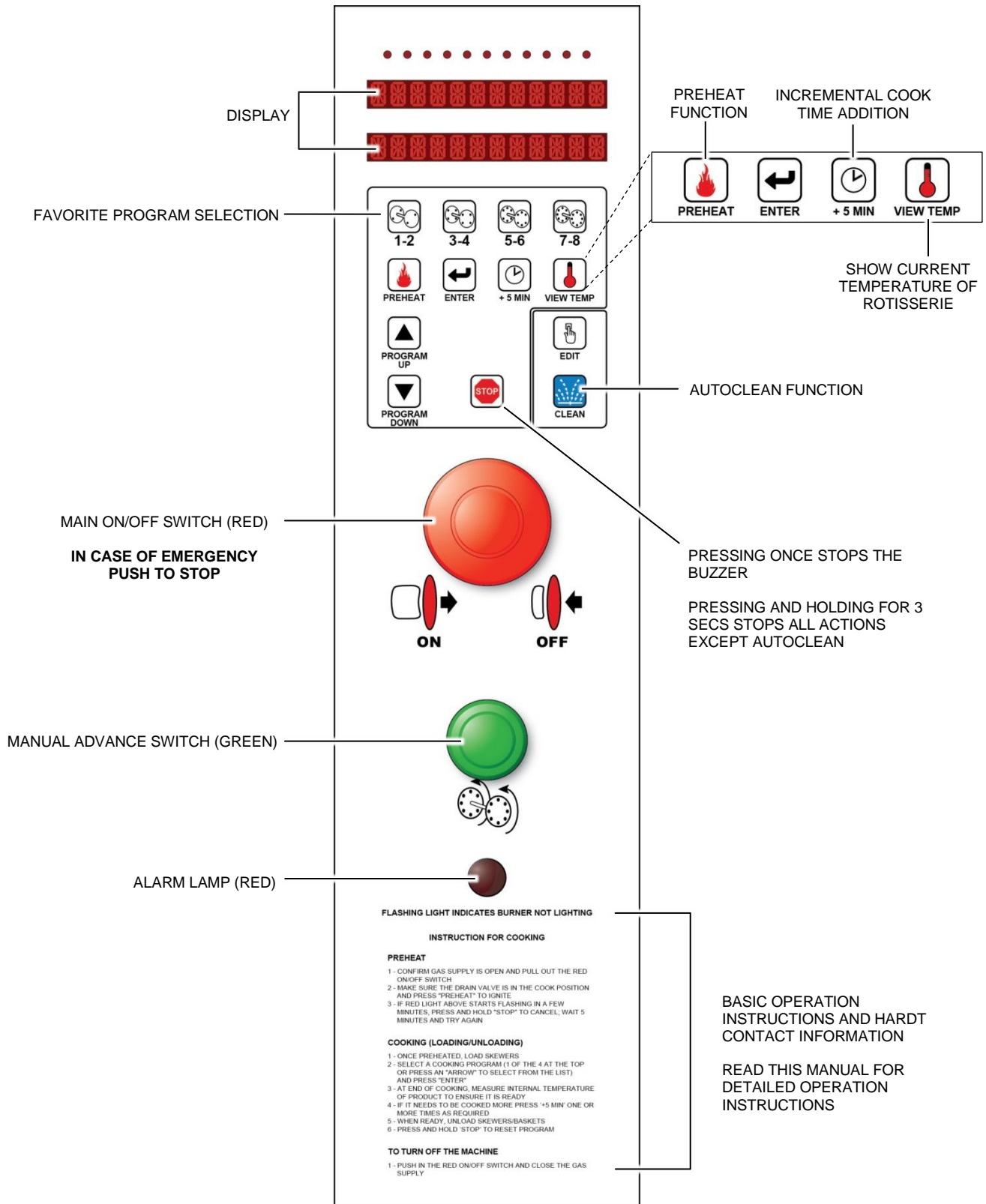

Figure 3-4

## 4. Operation



The rotisserie cannot be operated during a power failure. In the event of a prolonged power failure, do not attempt to operate the rotisserie. Turn off the main ON/OFF red switch and close the gas valve. When power has been restored, open the gas valve, pull out the main ON/OFF red switch and resume normal operation.



References will be made to an IDLE MODE in the next few sections that relate to rotisserie operation. When in IDLE MODE, the controller displays “PREHEAT OR CLEAN”.



### 4.1. Morning Startup



**ALWAYS TURN THE VENTILATION SYSTEM ON BEFORE STARTING THE ROTISSERIE. IT IS REQUIRED TO REMOVE COMBUSTION BY-PRODUCTS AND GREASE-LADEN AIR.**

**BEFORE STARTING THE ROTISSERIE, INSPECT THE COOKING CAVITY OF THE UNIT TO ENSURE THAT ALL FLAMMABLE MATERIAL HAS BEEN REMOVED TO PREVENT THE RISK OF FIRE.**

#### 4.1.1. Starting the Rotisserie

1. With power connected to the rotisserie, turn on the Inferno 4500 by pulling out the main ON/OFF red switch shown in Figure 3-4.
2. Make sure the Main Drain Valve Handle is set to Cook  as shown in Figure 4-1.
3. Make sure the gas valve to the rotisserie is opened.
4. Follow any special instructions scrolling on the display, if applicable.
5. Clean the strainers and turn on the ventilation hoods.
6. By referring to Figure 4-2, spray SOIL SHIELD evenly onto:
  - a. both (left and right) rotation plates
  - b. the center shaft (spray onto gloves, then spread onto shaft)
  - c. across the inner façade above the oven opening
7. Once these conditions have been filled, select PREHEAT  to ignite and the oven will begin the preheat cycle.

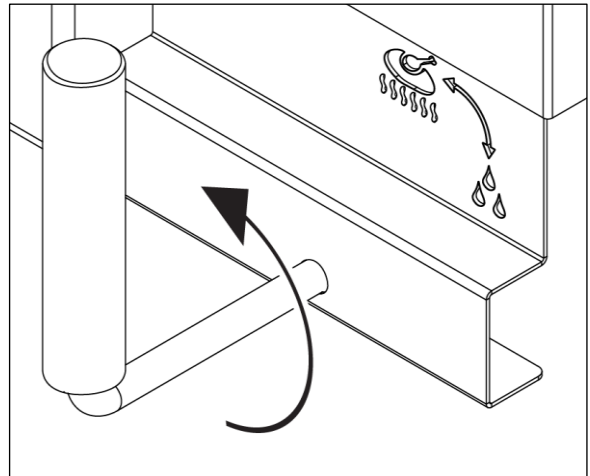

Figure 4-1

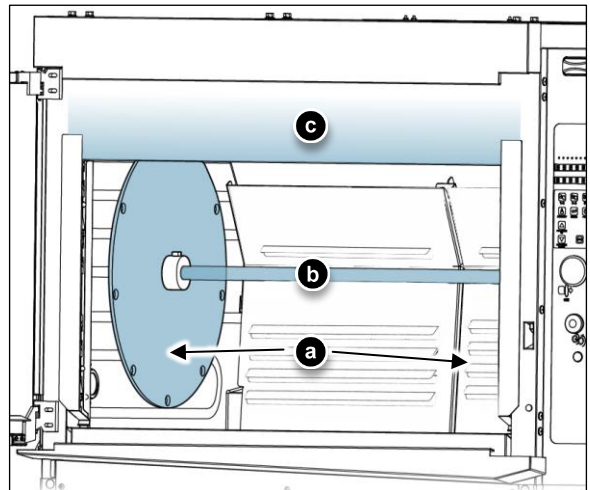

Figure 4-2



**If the red lamp is flashing indicating the burner did not light:**

- Press & hold STOP  for 3 seconds to cancel the cycle.
- Wait 5 minutes and try again.
- If the problem persists, see Section 6.2 Safety Lockout.

### 4.1.2. Grease Collection

Hardt offers an optional Heated Grease Collection Reservoir that is used to facilitate the collection and disposal of grease from the rotisserie. If no reservoir is obtained from Hardt, alternate methods of grease collection and disposal are required.

If the optional Heated Grease Collection Reservoir from Hardt is being used:

1. Ensure that the grease collection reservoir is clean and fully drained.
2. Verify that the collection reservoir is properly positioned under the grease drain from each rotisserie (Figure 4-3).
3. Plug in the grease collection reservoir.

If an alternative grease management system is in use, follow the instructions for daily care supplied by the manufacturer of that system.

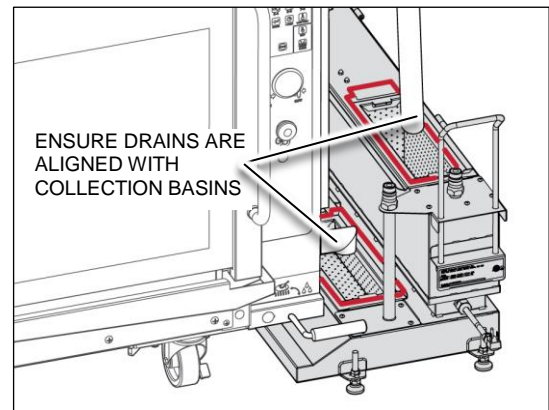

Figure 4-3

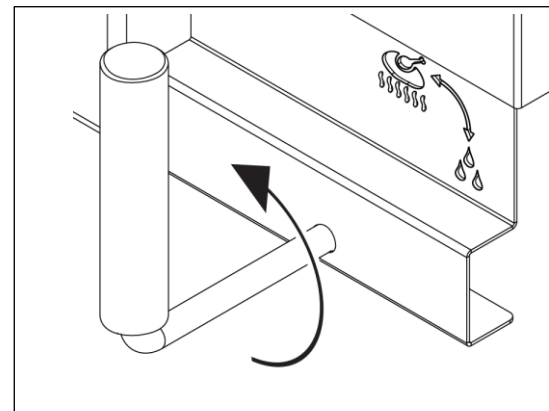



Figure 4-4

When operating the rotisserie, the drain valve must be set to 'COOK' , this will allow all grease and cooking effluent to drain out of the plumbing indicated in Figure 4-5. Single rotisseries use only the upper drain shown.

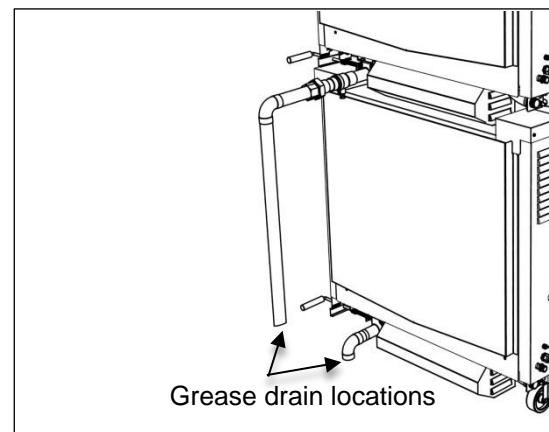

Figure 4-5

## 4.2. Cooking Procedure



**THE ROTISSERIE IS HOT. ENSURE YOU ARE WEARING OVEN MITTS AT ALL TIMES WHEN WORKING WITH THE HOT ROTISSERIE.**





- **NEVER LOAD PRODUCT INTO A ROTISSERIE WHICH IS NOT PREHEATED.**
- **CROSS CONTAMINATION OF RAW ONTO COOKED PRODUCT IS VERY DANGEROUS.**
- **DO NOT LOAD FRESH PRODUCT INTO ROTISSERIE UNTIL THE COOKING CYCLE IS COMPLETE AND ALL COOKED PRODUCT IS REMOVED FROM THE ROTISSERIE.**



Refer to the table on page 5 for a list of safe cooking temperatures and times.





**The procedures described here are basic. Hardt provides extensive cooking and food program support and training. Your organization may have specific instructions that should be followed instead of the ones listed here.**

1. Following a preheat cycle (see section 4.1.1), the display will indicate "OVEN READY" when the correct temperature for loading the rotisserie has been reached.
2. Open the door and load the product as per the procedure described in section 4.3.
3. Close the door.
4. Choose a FAVORITE PROGRAM SELECTION  or press **PROGRAM UP**  or **PROGRAM DOWN**  to select another program from the saved list. To select a program, press **ENTER** .

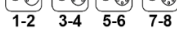

The numbers under the **FAVORITE PROGRAM SELECTION BUTTONS**  dictate how many skewers are to be used.

Select '1-2' if using one or two skewers, select '3-4' if using three or four skewers, etc.

5. At the end of the cook, measure product internal temperature. Refer to section 5 for special notes on product internal temperatures.
6. If the measured internal temperature is insufficient, press **+ 5 MIN**  to add five minutes to the cook cycle. The **+5 MIN**  button can be pressed up to 3 times to add a total of 15 minutes to the cook time. Repeat this step until correct internal temperature is reached.
7. Press **STOP**  and hold for 3 seconds to end and reset the program.
8. Unload skewers from rotisserie following the procedure described in section 4.3.2.

## 4.3. Loading & Unloading the Rotisserie



**CROSS CONTAMINATION OF RAW ONTO COOKED PRODUCT IS VERY DANGEROUS. DO NOT LOAD UNCOOKED PRODUCT INTO ROTISSERIE UNTIL COOKING CYCLE IS COMPLETE AND ALL COOKED PRODUCT IS REMOVED FROM ROTISSERIE.**



**USE PROTECTIVE CLOTHING WHEN LOADING AND UNLOADING THE ROTISSERIE.**

### 4.3.1. Loading the Skewers

When the rotisserie reaches operating temperature, skewers can be loaded.

Open the door to shut off the burner and to stop the drive rotation.

Use the green Manual Advance Switch (as indicated in Figure 3-4) to position sockets as required.



The orientation of the skewer in the socket will vary depending on the model of your equipment.

Follow these steps to properly load skewers into the rotisserie.

1. As indicated in Figure 4-6 insert the pointed end of the skewer into a hole in the plate on left side of rotisserie.
2. Align the other end of the skewer with the corresponding socket and push into place (See Figure 4-7).
3. Slide the skewer back to the left until the shoulder at the left end of the skewer is snug against the left end plate.
4. Check that the skewer is secured in position (holds in place).
5. Advance the drive to another position using the green manual advance switch. Repeat steps 1-5 as required.
6. Close the door, select the proper cooking program, and the rotisserie will begin to cook.

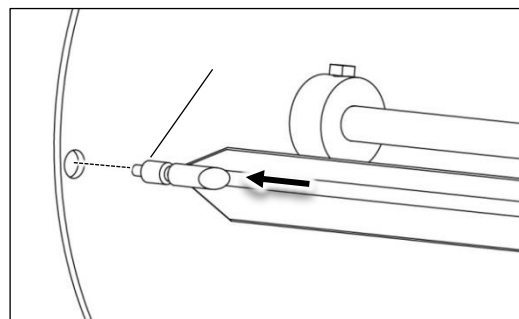

Figure 4-6

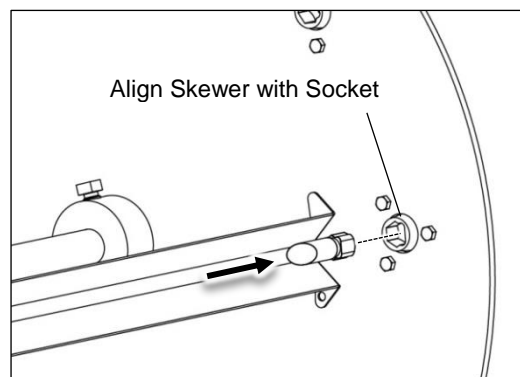



Figure 4-7



**USE PROTECTIVE CLOTHING WHEN LOADING AND UNLOADING THE ROTISSERIE.**



### 4.3.2. Unloading the Skewers

1. Open the door to shut off burner and to stop the drive from rotating.
2. Remove each skewer by lifting the left end, sliding the skewer to the left and then gently pivot the skewer out of the rotisserie. Place each skewer on a skewer cart or a cooked food table.
3. Use the green manual advance switch to position skewers (or baskets) as required for removal.
4. Close the door of the rotisserie to resume operation or cooking (burner will reignite).
5. If no further cooking is required, press and hold the **STOP**  button for three seconds to end the program.

## 4.4. Controller Functions

This section contains information for basic operation and programming of the Inferno 4500 system.

### 4.4.1. Buzzers and Alarms

(Press **STOP**  once to end a buzzer. Press and hold **STOP**  for 3 seconds to stop any action except an AUTOCLEAN cycle.)

- At the end of a preheat cycle when the correct temperature is reached, a buzzer sounds for 5 seconds and the yellow end of program light (Figure 3-1, Figure 3-2) turns on.
- If the rotisserie temperature then drops below 150°F (65.6°C), the red alarm lamp will flash and a message on the controller display will prompt to repeat the preheat cycle.
- At the end of a cooking cycle and of subsequent cook time additions, a buzzer sounds for 10 seconds and the yellow end of program lamp turns on.
- In case of a Safety Lock Out (gas burner does not light), the red alarm lamp (shown in Figure 3-4) will flash continuously.

### 4.4.2. Programming

The controls allow many of the rotisserie's parameters to be accessed and modified. Only the basic programming of "Favorites" is described in this manual. Additional modification of the parameters must be performed by an authorized service technician. Please call Hardt Customer Service for further information.

## 5. Maintenance



ENSURE YOU ARE WEARING INSULATED GLOVES AND AN APRON AT ALL TIMES WHEN WORKING WITH THE HOT ROTISSERIE.



**Allow a period of time for the rotisserie to reach a safe-to-touch temperature, but ensure that the oven is still warm to facilitate easier cleaning.**

### 5.1. Daily Cleaning

#### 5.1.1. Beginning of the Day

Ensure that the entire unit is clean by referring to section **5.1.4 Auto Clean Effectiveness Evaluation**. If it is not clean, perform an Auto Clean cycle by following the on-site cleaning laminates or referring to section **5.1.3 Cleaning at the End of the Day: Auto Clean Operation**.



**It is imperative that the rotisserie oven is properly clean and sanitized from the previous day. If an Auto Clean cycle was not run at that time, it must be run at the beginning of the day before a cook is initiated.**

#### 5.1.2. Cleaning Throughout the Day

It is recommended to clean the inner glass with a soft, damp cloth after every cooking cycle. This will lead to optimal cleaning results without scratching the glass. Avoid using scouring pads or cleaners with grit on glass.



**If the heated grease collection reservoir is installed, monitor the liquid level throughout the day and empty unit as required.**

### 5.1.3. Cleaning at the End of the Day: Auto Clean Operation





It is recommended to run the Auto Clean cycle at the end of the business day, after all cooking has been completed.

#### Description of the Auto Clean Operation

The Auto Clean cycle consists of a succession of activities that are completely and automatically controlled by the rotisserie. The sequence is as follows:

- **OVEN COOLDOWN:** A period of time required for the rotisserie to reach a safe temperature for cleaning.
- **PREWASH:** Fresh water is used for an initial flush of the drip pan.
- **SOAP WASH:** involves the repeated application of a cleaning agent followed by soaking and draining.
- **FIRST RINSE:** a rinsing cycle.
- **POWER RINSE:** another, different type of rinsing cycle.
- **FINAL RINSE:** a series of rinsing cycles involving water collection followed by draining.

#### Instructions for Auto Clean

1. Verify that there is sufficient degreaser in the bottle to run an Auto Clean cycle. If the level is too low, replace the bottle.
2. Open the door to the rotisserie.
3. Remove any large pieces that are left on the bottom of the drip pan.
4. Using a wet towel, clean the front channel, exterior panel and the inside door glass pane.
5. Rotate the Main Drain Valve Handle to Clean   as shown in Figure 5-2.
6. Close the rotisserie door and press **CLEAN**  and then **ENTER**  to start the cleaning cycle. Read the display. If the Auto Clean has begun it will read either, "CHECKING OVEN TEMPERATURE", "CLEAN COOLDOWN" or "PREWASH".
7. Clean the outside of the rotisserie following the convections outlined in section 5.4 Material Cleaning Guidelines.

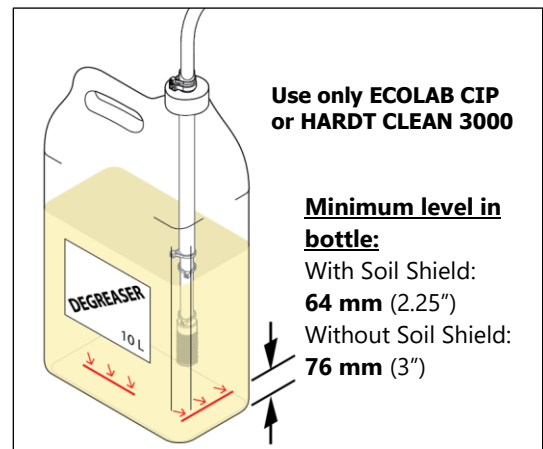

Figure 5-1

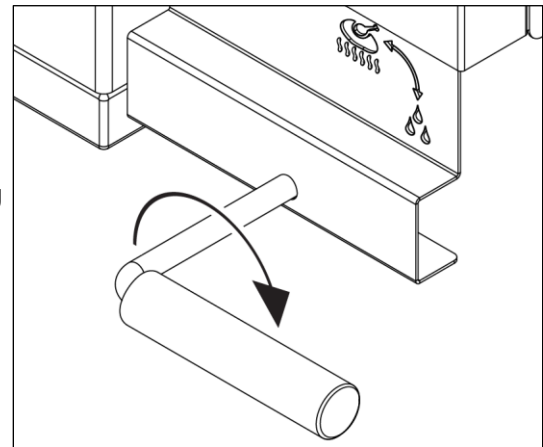

Figure 5-2



**If the display reads, "CLEAN COOLDOWN" the Auto Clean will not start immediately as the cooking cavity is too hot. DO NOT open the door to cool the rotisserie! It must cool on its own with the door closed for optimal Auto Clean performance and to avoid damaging the inside of the oven. The Auto Clean will start on its own when the unit has properly cooled.**

### 5.1.4. Auto Clean Effectiveness Evaluation

It is important to consider the condition of the rotisserie after the Auto Clean cycle is finished to verify that the cleaning operations are functioning correctly. The following images illustrate three states of cleanliness and their related interpretation.



**COOKING IN AN OVEN WITH RESIDUE BUILDUP CAN CAUSE A FIRE.**

*Figure 5-3: Dirty Cavity:*

The image shows a cavity that has NOT been cleaned sufficiently to cook in. This may be due to the cleaning procedures not being followed on a consistent basis or the Auto Clean system having not functioning properly for an extended period of time.

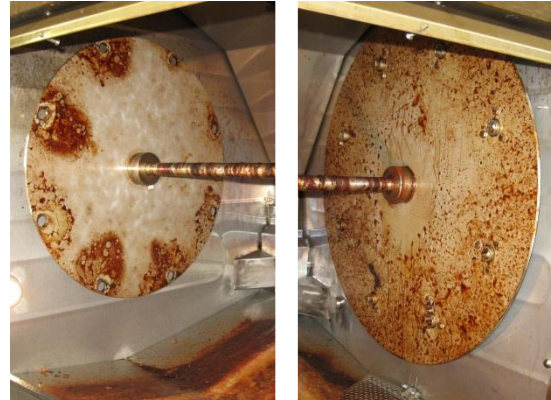

Figure 5-3

*Figure 5-4: Mostly Clean Cavity:*

It will be necessary to clean the rotisserie by hand using regular oven cleaner (in a spray bottle) and a scrub pad or scraper to remove the build-up of carbon prior to running the Auto Clean cycle. The Auto Clean function will only clean the grease from 1 day's worth of cooking. It may take a few days of Auto Clean and hand scraping to get the unit back to the point where following the correct procedures will produce a clean rotisserie in the morning.

If the rotisserie cavity looks like what is shown in Figure 5-4, remove the residual flakes with a scrub pad PRIOR to cooking.

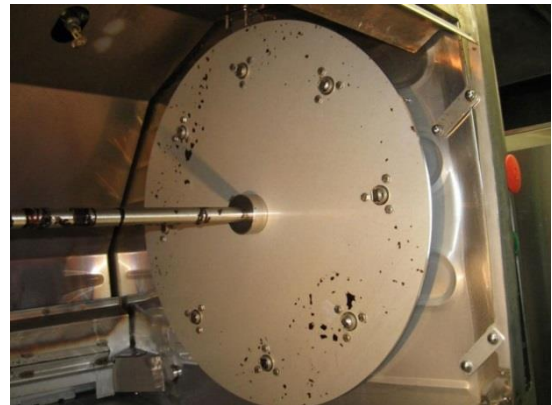

Figure 5-4

*Figure 5-5 Sufficiently Clean Cavity*

Figure 5-5 shows a rotisserie cavity that is sufficiently clean and in which cooking may be performed.

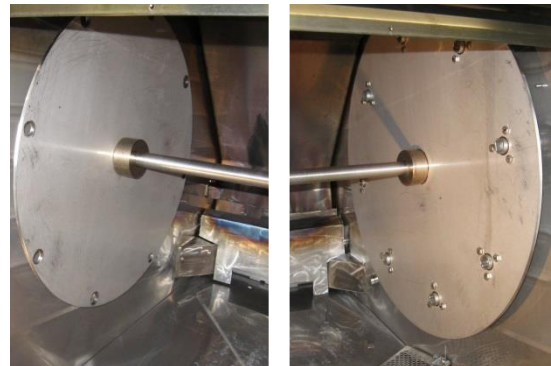

Figure 5-5

## 5.2. Weekly Inspection

Thoroughly inspect the venting components supplied with the rotisserie for signs of damage (dents, perforations, etc.). Replace with certified Hardt components if required. Ensure that the electrical cord, water and gas lines are free from damage and kinks.

## 5.3. Flame Shields

It is important that the flame shields on the back wall remain secured in place for optimal performance. At different intervals, it is good practice to ensure that they are properly in place by referring to the illustrations on this page. In the event that they need to be removed (i.e. to have access to the back burner), do the following:

1. Starting with the *right* flame shield, lift it out of its upper slot (A), side wall tab (B) and floor stopper (C).

Carefully remove it out of the oven cavity.

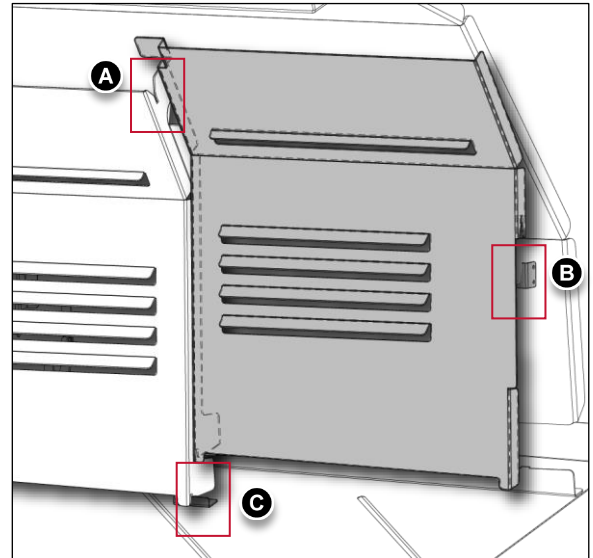

Figure 5-6

2. Lift the *left* flame shield out of its side wall tab (B) and floor stopper (C).

Carefully remove it out of the oven cavity.

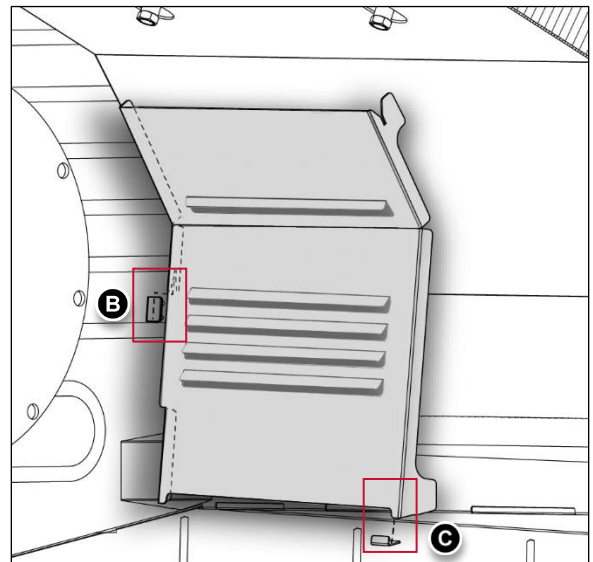

Figure 5-7

3. Reinstall the flame shields in reverse order; *Install left shield first, followed by the right shield.*

**Ensure all tabs are correctly inserted into their corresponding slots and ensure that the shields are positioned behind the floor stopper.**

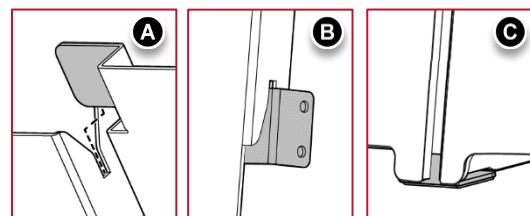

Figure 5-8

## 5.4. Material Cleaning Guidelines

### 5.4.1. Guidelines for Cleaning Glass Surfaces

- Wipe off residues with a soft cloth or a paper towel.
- Remove baked-on residues using a wooden or plastic scraper. Avoid using a metal scraper as it may scratch the glass.
- Surfaces may be cleaned using a soft cloth with mild soap and water. Alternately, a glass cleaning spray with paper towels may be used.
- Avoid scratching the surface of the glass.



**DO NOT USE abrasive scouring powder or abrasive cleansers on the glass door, the lamp's glass shield and the control panel.**

**DO NOT USE metallic scouring pads.**

**DO NOT USE metal scrapers.**

**AVOID putting cold water or a cold damp cloth onto the hot glass as this may cause the glass to crack and shatter**

### 5.4.2. Guidelines for Cleaning Metal Surfaces

- Wipe up spills and residues with a cloth or paper towel.
- Remove baked-on residues using a wooden or plastic scraper. Avoid using a metal scraper on exterior surfaces as it may scratch the metal finish of the rotisserie.
- Surfaces may be cleaned using a soft cloth with mild soap and water. Alternately, a spray-on degreaser may also be used but only on stainless steel surfaces following the handling procedure outlined on the product label. Do not apply degreasers or other harsh chemicals to painted surfaces as this may permanently affect the look and performance of the finish.
- The look of stainless steel surfaces can be improved by using stainless steel polishing creams. Follow the instructions on the packaging of the polishing product being used.
- Avoid scratching or marring metal surfaces.
- For stubborn build up on the interior stainless steel surfaces of the oven (including around the door's opening), bristle brushes or mild scouring pads can be used. Refer to the daily cleaning laminates for details.



**DO NOT USE abrasive scouring powder or abrasive cleansers.**

**DO NOT USE metallic scouring pads.**

**DO NOT USE metal scrapers on exterior surfaces.**

**DO NOT USE corrosive cleaning agents.**

## 6. Troubleshooting



**DISCONNECT POWER TO THE ROTISSERIE BEFORE ANY MAINTENANCE, SERVICE OR CLEANING IS PERFORMED.**

**ROTISSERIES EQUIPPED WITH CASTERS ARE SECURED IN PLACE USING A RESTRAINING CABLE LOCATED ON THE RIGHT REAR UNDERSIDE OF THE ROTISSERIE. THIS CABLE MUST BE DISCONNECTED PRIOR TO REMOVING THE ROTISSERIE AND CAUTION MUST BE TAKEN TO ENSURE IT IS CONNECTED ONCE THE ROTISSERIE HAS BEEN RETURNED TO ITS ORIGINAL POSITION.**

**THE ROTISSERIE IS HOT WHEN OPERATING. EXERCISE CAUTION WHEN WORKING NEAR THE HOT ROTISSERIE.**

**WEAR APPROPRIATE PROTECTIVE CLOTHING.**

### 6.1. Rotisserie Does Not Operate

The rotisserie does not operate when the red main ON/OFF is pulled out (i.e. drive does not turn, and no lights in cavity).

#### **SOLUTION:**

- Verify that the door is fully closed. The magnetic door switch disables or enables the ignition system.
- Check rotisserie electrical power: If the rotisserie's lights are off, check the circuit breaker on the back of the unit as shown in Figure 3-1 and Figure 3-2. If the circuit breaker is 'OFF' (tripped), return to 'ON'.
- If this circuit breaker is 'ON', ensure that the power cord is plugged into the wall and that there is power coming from the socket. If power is available and the rotisserie still does not operate, contact your local authorized service partner.

### 6.2. Safety Lockout

When a preheat cycle has been started, the drive will rotate and the igniter will attempt to light the burner. If there is no flame after six minutes, the rotisserie will go into Safety Lockout.

Possible causes include: the gas supply valve is shut off, the flame sensor is not sensing flame or there is some component failure.

#### **SOLUTION:**

- If the rotisserie goes into Safety Lockout, press and hold **STOP**  for 3 seconds to end the cycle or push the red main ON/OFF switch to turn the rotisserie off.
- Verify that the gas supply valve to the rotisserie is open. Try starting ignition again by pulling the red main ON/OFF switch out and by starting a preheat cycle as described in Section 4.1.1.

If the rotisserie goes into Safety Lockout again there is most likely a component failure. Turn the rotisserie off (by pushing the red main ON/OFF switch) and contact your local authorized Hardt service provider.

## 6.3. Replacing the Halogen Lamp

1. Turn rotisserie off (push in main ON/OFF switch) and disconnect the power cord from the wall receptacle.
2. Allow rotisserie to cool down.
3. Remove the light access panel located on the left side of the rotisserie by loosening the thumb screws (by hand or using a screwdriver) (Figure 6-1).
4. Loosen the wing nuts on the light support bracket in order to access the light (Figure 6-2).
5. While wearing gloves, gently pull the light bulb out of its fixture (Figure 6-3).

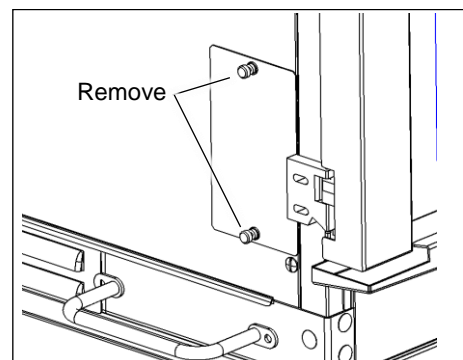

Figure 6-1



**Do not touch the replacement bulb with bare fingers or dirty gloves.**

6. Install a new bulb.
7. Position bracket so that the light is oriented towards the center shaft of the rotisserie. Hand tighten the two wing nuts.
8. Reinstall access panel.
9. Plug the power cord back into the wall receptacle.
10. Turn the rotisserie on (pull out main ON/OFF switch).
11. Verify that the replaced bulbs function correctly (it is normal for the lights to take about 6 seconds to light after the main switch is pulled ON). If not, repeat the first four steps of this procedure and make sure the bulb was correctly inserted in the socket. Reinstall the access panel, turn the rotisserie ON and recheck. If problems persist, contact your local authorized service partner.

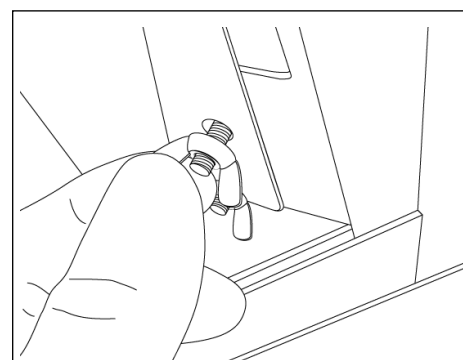

Figure 6-2

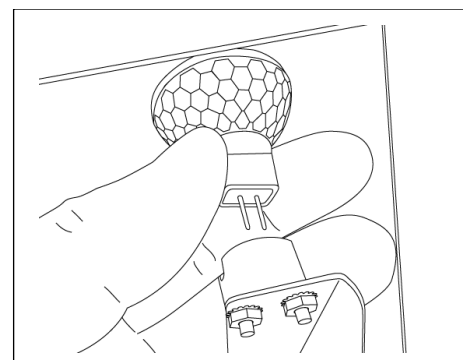

Figure 6-3

## 7. Accessories & Parts

### 7.1. Replacement Parts

During the life of the appliance, some parts may require replacement by a qualified professional. These parts are listed below.

- Flame sensor (6719.kit). - Installable only by authorized service personnel.
- Light bulb (8998) - Installable by both operators and authorized service personnel.
- Battery (6665) - Installable only by authorized service personnel.