

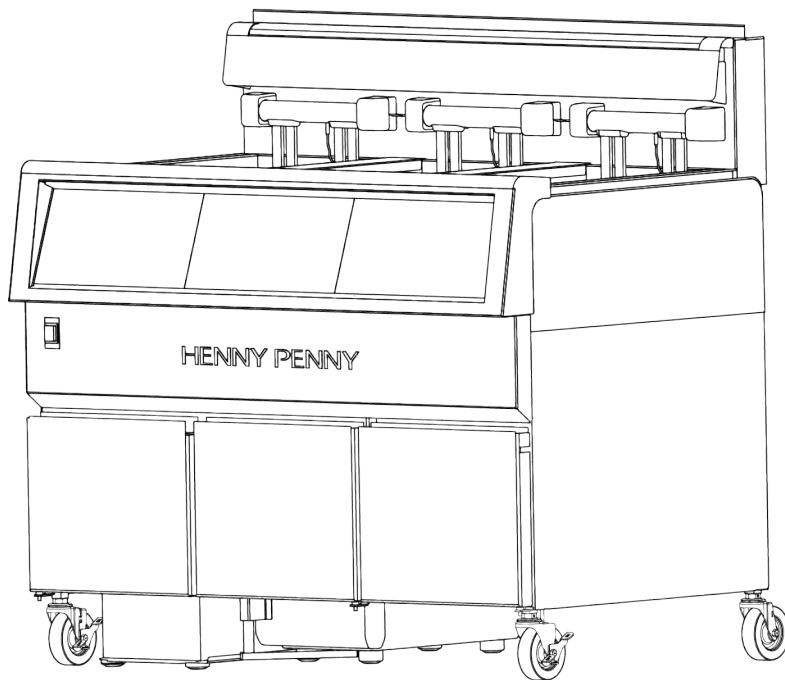

**OPERATION
MANUAL**

F5 Series Fryer Electric



OFE-51X

FM05-244A



Table of Contents

Safety.....	iii
Chapter 1 Introduction.....	1
1.1 Introduction.....	1
1.2 Model configuration and identification.....	1
1.3 Fryer dimensions and weights.....	2
1.3.1 Critical dimensions.....	2
1.3.2 Weights.....	3
1.4 Proper Care.....	4
1.5 Technical Support.....	4
1.6 Disposal of Equipment.....	4
Chapter 2 Installation.....	5
2.1 Introduction.....	5
2.2 Unpacking.....	5
2.3 Selecting the Fryer Location.....	6
2.3.1 Required clearances.....	6
2.3.2 Ventilation of the Fryer.....	7
2.4 Leveling the fryer.....	7
2.5 Electrical requirements.....	9
2.5.1 Electrical specifications.....	9
Chapter 3 First time use.....	11
3.1 Commissioning.....	11
3.2 Start up training.....	11
3.3 Control setup.....	11
3.3.1 To set up controls.....	11
Chapter 4 Basic Operation.....	15
4.1 Component overview.....	15
4.2 Filling and adding oil.....	17
4.2.1 Manually filling an empty vat.....	17
4.2.2 Topping off oil.....	18
4.2.3 Replacing the JIB (Jug-in-Box).....	18
4.3 Turning on power and heating oil.....	18
4.3.1 Performing the daily fryer precheck.....	18
4.3.1.1 Storing night covers.....	19
4.3.2 Powering up the F5.....	19
4.3.3 Heating the oil.....	19
4.4 Homescreen.....	21
4.4.1 Oil info.....	22
4.5 Cooking food items.....	22
4.5.1 Single timer cooking screen.....	23
4.5.2 Full vat - starting a timer.....	24
4.5.3 Split vat - starting a timer.....	24
4.5.4 Stopping a timer.....	25
4.5.5 Repeating a timer.....	25
4.5.6 Incompatible food items.....	26

4.6	Oil Management	26
4.6.1	Express Filter	27
4.6.2	Managing express filters during busy periods	29
4.7	Shutting down the F5.....	29
4.7.1	F5 shutdown checklist	29
4.7.2	Filter pan assembly	30
4.7.2.1	Filter pan maintenance throughout the day	30
4.7.2.2	Cleaning the filter pan	31
4.7.3	Cleaning the basket hanger	34
4.7.4	Turning off the F5.....	34
Chapter 5	Settings	35
5.1	General	35
5.1.1	Volume.....	36
5.2	Oil & Filter	36
5.2.1	Express filter	37
5.2.2	Daily filter	37
5.2.3	Drain to Pan	38
5.2.4	Dispose Oil.....	39
5.2.5	Fill Vat.....	40
5.3	Food Item Settings	41
5.3.1	Manage Food Items	41
5.3.1.1	Editing a food item.....	42
5.3.1.2	Copying a food item.....	43
5.3.1.3	Deleting a food item.....	43
5.3.2	Food Item Order	43
5.3.3	Create Food Item	44
5.3.3.1	Advanced Cooking Parameters	47
5.4	Information	48
5.4.1	About Fryer	48
5.4.2	Export	48
5.5	Advanced	48
5.6	Service.....	49
5.7	Help.....	49
5.8	Shutdown Vat	49
Chapter 6	Maintenance	51
6.1	Maintenance Schedule	51
6.2	Maintenance Procedures	51
6.2.1	Clean Behind Fryer	51
6.2.2	Deep Clean	51
6.2.3	O-Ring replacement	52
Chapter 7	Troubleshooting	55
7.1	Error Messages	55
7.2	Troubleshooting Guide	58
Chapter 8	Parts and Accessories	65
8.1	Fryer Accessories	65

Safety

Henny Penny fryers have many safety features incorporated. However, the only way to ensure safe operation is to fully understand the proper installation, operation, and maintenance procedures. The instructions in this manual have been prepared to aid you in learning the proper procedures. Where information is of particular importance or is safety related, the words DANGER, WARNING, CAUTION, or NOTICE are used. Their usage is described as follows:

 DANGER	DANGER! indicates hazardous situations which, if not avoided, will result in death or serious injury.
DANGER!	
 WARNING	WARNING! indicates hazardous situations which, if not avoided, could result in death or serious injury.
WARNING!	
 CAUTION	CAUTION! indicates hazardous situations which, if not avoided, could result in moderate or minor injury.
CAUTION!	
<i>NOTICE</i>	<i>NOTICE</i> is used for information considered important regarding property damage.

These are the original version controlled Henny Penny instructions for Open Fryer Electric (OFE) model 51x (OFE 51x) or F5 fryer. This manual is available on the Henny Penny Public website (www.hennypenny.com). Read these instructions completely prior to installation and operation of this appliance to ensure compliance to all required installation, operation and safety standards. Read and obey all safety messages to avoid damage to the appliance and personal injury.



WARNING

- **This fryer must be installed and used in a way that water does not contact the oil which can cause splashing and boiling over of oil and steam leading to personal injury; excludes normal product moisture.**
- **Burn risk! Do not move the fryer or filter drain pan while containing hot oil. Personal injury or serious burns can result from splashing hot oil.**

This appliance is intended for commercial use in kitchens of restaurants, bakeries, hospitals, etc. but not for the continuous mass production of food such as in a factory setting. During use the units airborne A-weighted emission sound pressure is below 70 db(A). All repairs must be performed by the manufacturer, its service agent or similarly qualified persons in order to avoid a hazard.

Always use strain relief. The provided power cord must be installed with a strain relief in a way that if the strain relief fails, wires L1, L2, L3 and N must draw taunt and fail first. If the supplied power cord or an existing one becomes damaged, do not use it; rather, replace it with a known good power cord. The powercord must be replaced by the manufacturer, its service agent or similarly qualified persons in order to avoid a hazard.

Proper daily, weekly, monthly, quarterly and yearly maintenance must be performed on this appliance to ensure safe and continuous operation. This appliance must never be cleaned with a water jet or steam cleaning tool. Cleaning brushes are shipped with the appliance and proper cleaning instructions are included in this manual.

Proper maintenance also increases the usable life of the appliance and oil, which reduces lifetime operating costs. Additionally, old oil increases the possibility of surge boiling and fire due to the reduced flash point of the oil. The oil temperature must never exceed 450° F (230°C).

This appliance is not intended for use by persons (including children) with reduced physical, sensory or mental capabilities, or lack of experience and knowledge, unless they have been given supervision or instruction concerning use of the appliance by a

person responsible for their safety. Children should be supervised to ensure that they do not play with the appliance.

This appliance is not intended to be operated by means of an external timer or a separate remote control system.

Chapter 1 Introduction

1.1 Introduction

This guide takes Operators through all the aspects that make up the F5 series fryer.

1.2 Model configuration and identification

The F5 is available in the four models shown in [Figure 1-1 F5 models, page 1](#) and can be ordered with either full (1) or split vats (2) as shown in [Figure 1-2 Full and split vat, page 2](#).

INFO: Refer to [Figure 1-1 F5 models, page 1](#) for the location of the filter pan, JIB, or oil reservoir specific to your F5 model.

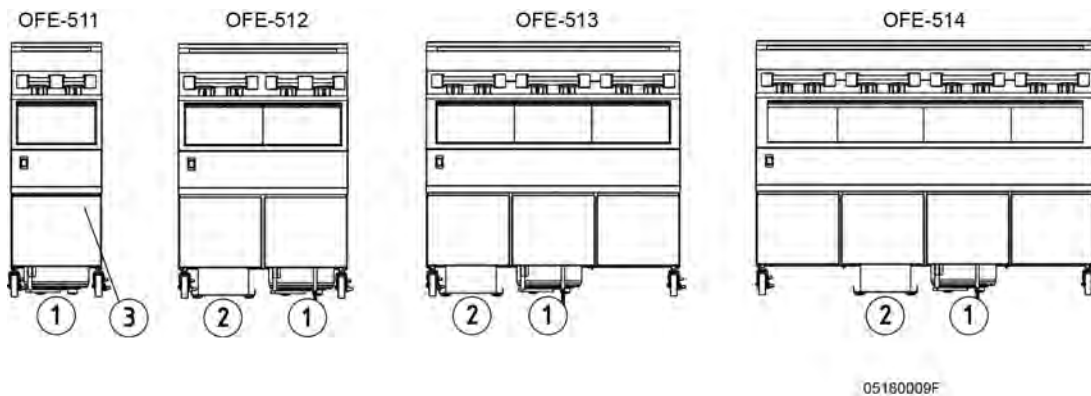

Figure 1-1 F5 models

Table 1-1 Filter pan, JIB, or oil reservoir location

Ref.	Component
1	Filter pan
2	JIB (jug-in-box)
3	Oil reservoir (behind door)

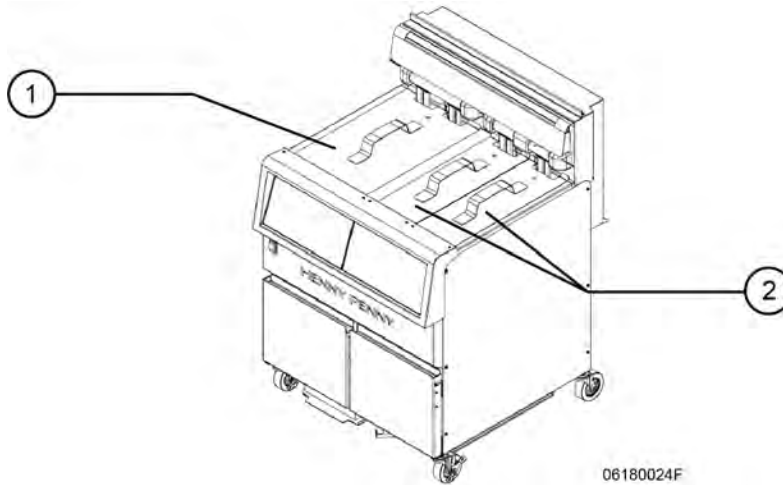

Figure 1-2 Full and split vat

1.3 Fryer dimensions and weights

This section lists the specifications for the OFE-51X fryer.

1.3.1 Critical dimensions

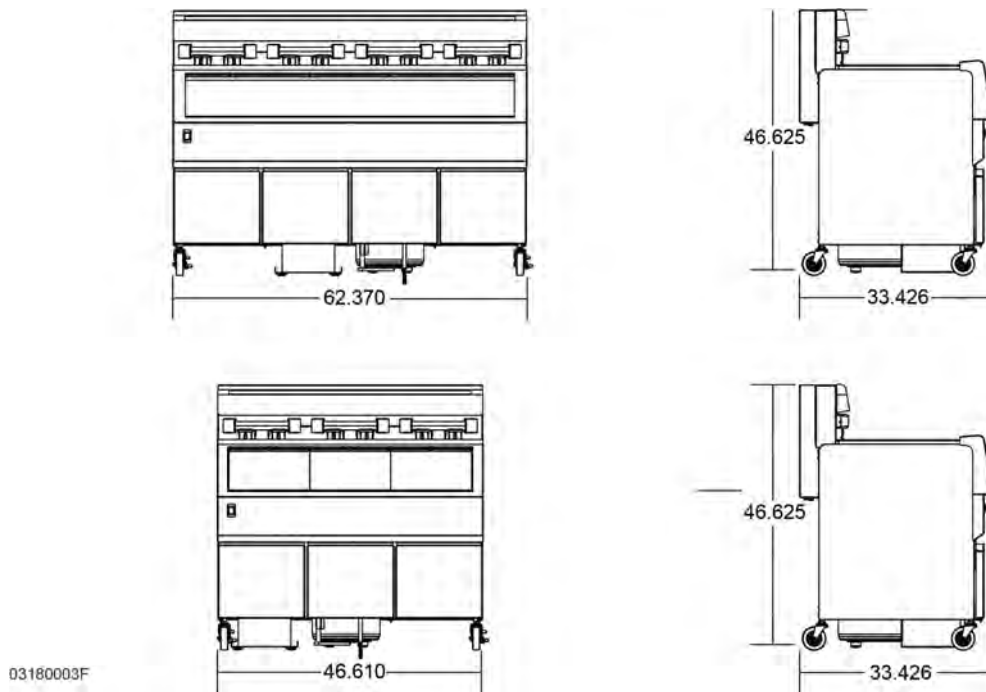

Figure 1-3 Critical dimensions 3 and 4 vat units

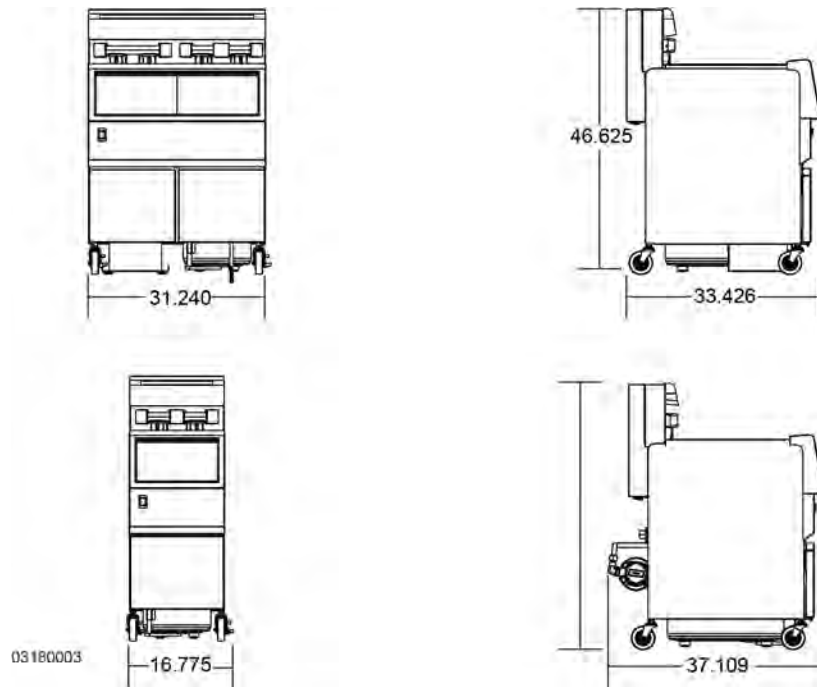

Figure 1-4 Critical dimensions 1 and 2 vat units

1.3.2 Weights

Table 1-2 Crated Weights

Vat Config.	OFE-511	OFE-512	OFE-513	OFE-514
Full	302 lb (137 kg)	441 lb (200 kg)	528 lb (240 kg)	702 lb (319 kg)
Split	317 lb (144 kg)	472 lb (214 kg)	606 lb (275 kg)	758 lb (344 kg)

1.4 Proper Care

Similar to other food service equipment, the Henny Penny open fryer requires care and maintenance. Requirements for the maintenance and cleaning are contained in this manual and must become a regular part of the operation of the unit at all times, see [6.1 Maintenance Schedule, page 51](#). Proper daily, weekly, monthly, quarterly and annual maintenance must be performed on this appliance to ensure safe and continuous operation. Proper maintenance also increases the usable life of the appliance and oil, which reduces lifetime operating costs. Additionally, old oil increases the possibility of surge boiling and fire due to the reduced flash point of the oil.

1.5 Technical Support



Should you require assistance from technical support inside the U.S. or Canada, contact Henny Penny Technical Support. at 800-417-8405 or technicalservices@hennypenny.com for all service needs. Outside of the U.S. contact technicalservices@hennypenny.com or your local distributor for assistance.

1.6 Disposal of Equipment



As of August 16, 2005, the Waste Electrical and Electronic Equipment directive went into effect for the European Union. Our products have been evaluated to the WEEE directive. We have also reviewed our products to determine if they comply with the Restriction of Hazardous Substances directive (RoHS) and have redesigned our products as needed in order to comply. To continue compliance with these directives, this unit must not be disposed as unsorted municipal waste. For proper disposal, please contact your nearest Henny Penny distributor. As of August 16, 2005, the Waste Electrical and Electronic Equipment directive went into effect for the European Union. Our products have been evaluated to the WEEE directive. We have also reviewed our products to determine if they comply with the Restriction of Hazardous Substances directive (RoHS) and have redesigned our products as needed in order to comply. To continue compliance with these directives, this unit must not be disposed as unsorted municipal waste. For proper disposal, please contact your nearest Henny Penny distributor.

Chapter 2 Installation

2.1 Introduction

This section provides the unpacking and installation instructions for the Henny Penny OFE-51X fryer.

2.2 Unpacking



WARNING

- Heavy object! See the table in [1.3.2 Weights, page 3](#) for the weight of your specific model. Take care when moving the fryer to prevent personal injury.
- Shock hazard. Do not puncture the fryer with any objects such as drills or screws as component damage or electrical shock could result. Installation of this unit should be performed only by a qualified service technician.

INFO: Any shipping damage should be noted in the presence of the delivery agent and signed prior to his or her departure.

- 1) Carefully cut and remove banding straps.
- 2) Lift the main box off the fryer.
INFO: This procedure should be performed in an area with high ceilings to avoid damage to the unit and ensure sufficient clearance.
- 3) Remove drain pan from the top of the fryer (1), see [Figure 2-1 Unpacking, page 6](#).
- 4) Remove the JIB shelf from the fryer (2).
- 5) With the fryer slightly raised, remove wood blocking support (3).
- 6) Carefully push fryer sideways in the direction of the removed wood blocking. Make sure the casters are rolling on the pallet deck board surfaces. Do not allow casters to drop between pallet surface spaces. Ease fryer off the pallet edge and clear of pallet (4 & 5).

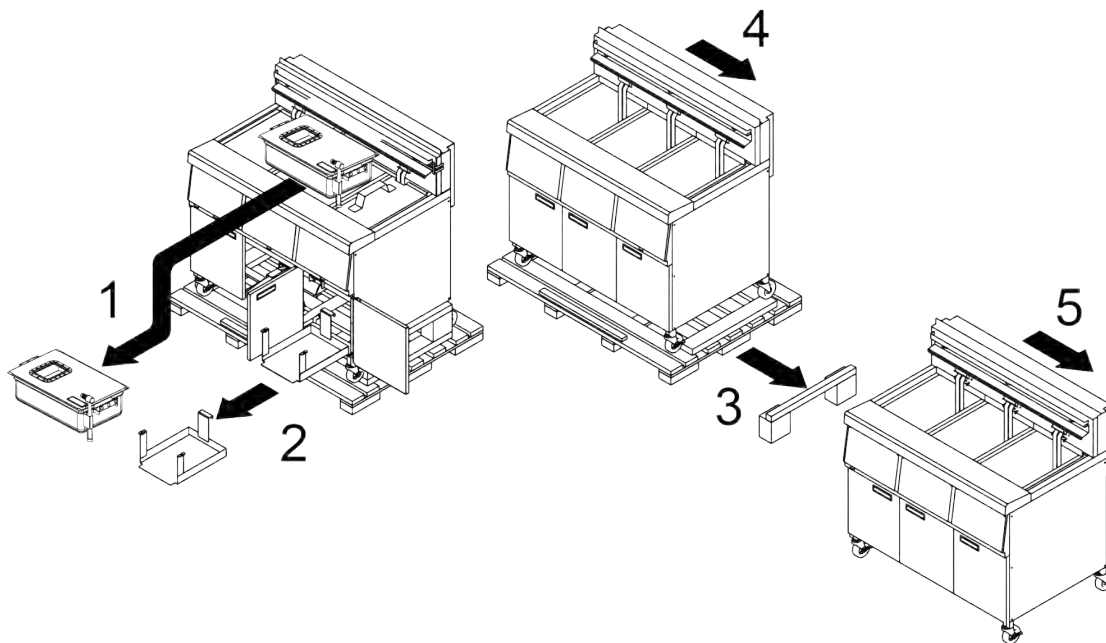

Figure 2-1 Unpacking

2.3 Selecting the Fryer Location

This section provides requirements for clearances and ventilation when selecting a location for the fryer.



WARNING

- Position and install fryer to prevent tipping or movement. Failure to do so may cause severe burns from splashing hot oil.
- This fryer must be installed and used in a way that water does not contact the oil which can cause splashing and boiling over of oil and steam leading to personal injury; excludes normal product moisture.

2.3.1 Required clearances

Surface	Required Clearance
Sides	2 in (51 mm) from combustible materials or other heat producing equipment; otherwise no clearance required.
Back	6 in (152 mm) for air flow and connections.

Front	30 in (762 mm) for removal of filter pan.
Top	11 in (280 mm) for units with auto lift.

2.3.2 Ventilation of the Fryer



WARNING

Ventilation must conform to local, state, and national codes or personal injury / damage to the fryer could result. Consult your local fire department or building authorities.

The fryer should be located with provision for venting into adequate exhaust hood or ventilation system. This is essential to permit efficient removal of steam exhaust and frying odors. Special precaution must be taken in designing an exhaust canopy to avoid interference with the operation of the fryer. We recommend you consult a local ventilation or heating company to help in designing an adequate system.

2.4 Leveling the fryer

To ensure consistent oil coverage in the vat and easy movement of the filter pan, the fryer should be level from side-to-side and front-to-back. Using a level as a guide, adjust casters to level the fryer, see [Figure 2-2 Leveling the Fryer, page 8](#) for level placement. Casters are adjustable up to 1.562 in (40mm). Adjust the casters by performing the following procedure:

- 1) Loosen the hex key set screw (1) for the caster that needs to be adjusted, see [Figure 2-3 Caster Adjustment, page 8](#).
- 2) Turn caster clockwise to lower the fryer or counterclockwise to raise the fryer as necessary.
- 3) Check the level (1) on top of the fryer to ensure the caster has been adjusted properly.
- 4) Repeat steps 1 thru 3 for each caster that needs to be adjusted until the fryer is level and ensure all four casters contact the floor—some casters may need no adjusting.
- 5) Tighten the hex key set screw on all casters that were adjusted.

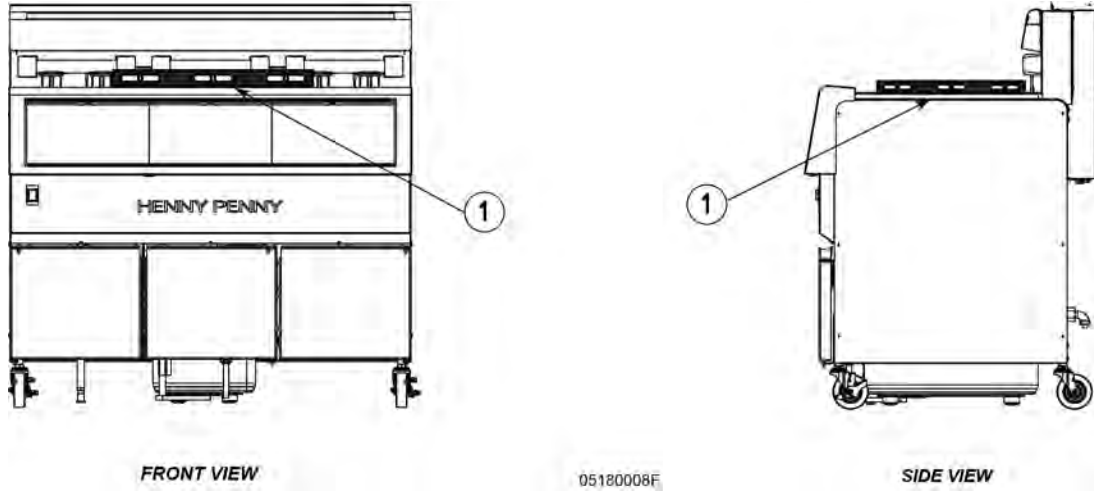

Figure 2-2 Leveling the Fryer

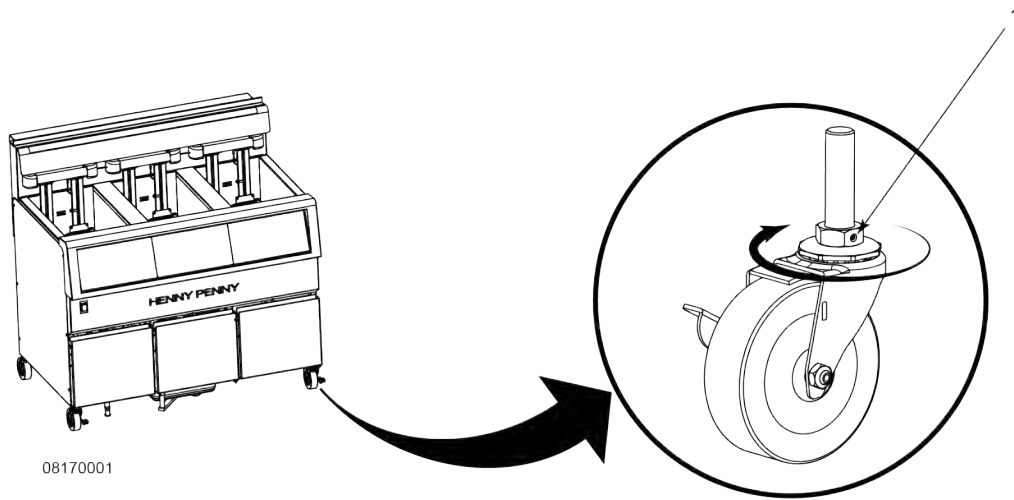

Figure 2-3 Castor Adjustment

2.5 Electrical requirements



WARNING

- This fryer must be adequately and safely grounded (earthed). Failure to do so may result in electrical shock.
- The main power switch on this appliance does not disconnect all line conductors. This appliance must be equipped with an external circuit breaker which will disconnect all ungrounded (unearthed) conductors. Failure to do so may result in electrical shock.

Check the data plate mounted on the inside of the left door to determine electrical requirements for the fryer, see [Figure 2-4 Data Plate Location, page 9](#). Refer to local electrical codes for correct grounding (earthing) procedures or in absence of local codes refer to the National Electrical Code ANSI/NFPA No. 70 (the current edition). Each vat has its own power cord assembly. An all pole separate disconnect switch with proper capacity fuses or breakers must be installed at a convenient location between the fryer and the power source. The disconnect switch must be installed according to national and local codes. It should be an insulated copper conductor rated for 600 volts and 90° C. For runs longer than 50 feet (15.24 m) use the next larger wire size. CE units require a minimum wire size of 6 mm to be wired to the terminal block. It is recommended that a 30 mA rated protective device such as a residual current circuit breaker (RCCB) or ground fault circuit interrupter (GFCI) be used on the fryer circuit.



01180386

Figure 2-4 Data Plate Location

2.5.1 Electrical specifications

Electrical specifications for available voltages are provided in the following table. Electrical requirements for each fryer are found on the inside of the left door, see [Figure 2-4 Data Plate Location, page 9](#).

INFO: Amperage listed is for the heat circuit, additional amperage required to operate non-heating components.

Table 2-1

Volts	Phase	Hertz	KW per well	Amps per well	Wire
208	3	60	14.0	39.4	3+G
240	3	60	14.0	34.2	3+G
220 / 380	3	50 / 60	14.0	24.3	3NG
230 / 400	3	50 / 60	14.0	24.3	3NG
240 / 415	3	50 / 60	14.0	24.3	3NG

Chapter 3 First time use

3.1 Commissioning

Both the commissioning and startup training for your new fryer are handled by your local Henny Penny distributor. Commissioning is typically performed just before your F5 start up training and includes, but is not limited to the following steps:

- Ensure all packaging is removed from the drain pan and fryer.
- Wipe out and rinse each vat removing all liquids once clean.
- Assemble the drain pan.
- Manually fill each vat with oil.
- Install a fresh JIB under the primary vat.
- Perform control setup.
- Test each system on the fryer.

For questions about commissioning and start-up training, please contact Henny Penny Technical Support at (800) 417-8405 in the U.S. or Canada, or for other countries (937) 456-8405. If you prefer email, contact us at technicalservices@hennypenny.com.

3.2 Start up training

Start-up training ensures you and your team understand operation and maintenance of your F5 open fryer.

3.3 Control setup

The touchscreen controls need to be set up the first time they are turned on. Control setup is completed by your local Henny Penny distributor during the commissioning of your F5 open fryer. Control setup also needs to be performed in the event a control is replaced, or a factory reset is applied.

3.3.1 To set up controls

To set up a new control, or a control where a factory reset is applied, perform the following steps:

- 1) Turn the main power switch on.
- 2) Tap the circle to get started, see [Figure 3-1](#), page 12.

- 3) Select fryer type **Electric** for models OFE-511, OFE-512, OFE-513, OFE-514. Select fryer type **Gas** for models OFG-511, OFG-512, OFG-513, OFG-514, then tap the serial number.

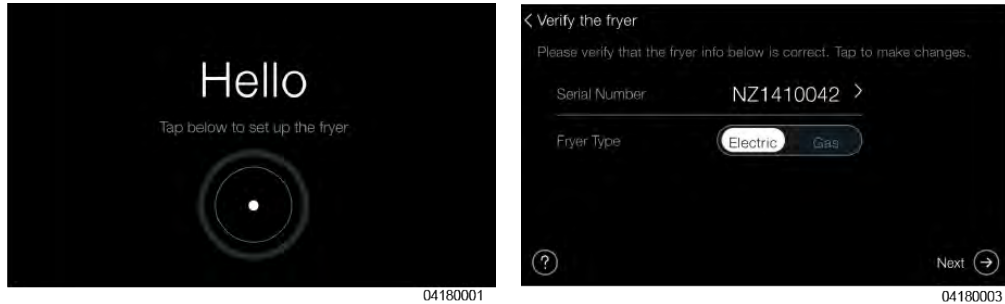

Figure 3-1

- 4) Use the on screen keyboard to type your serial number. See [Figure 3-2](#), page 12 and [Figure 2-4 Data Plate Location](#), page 9 to locate and enter the serial number on your fryer.
- 5) Select the number of vats and configure them to either full or split to match the configuration of your fryer.

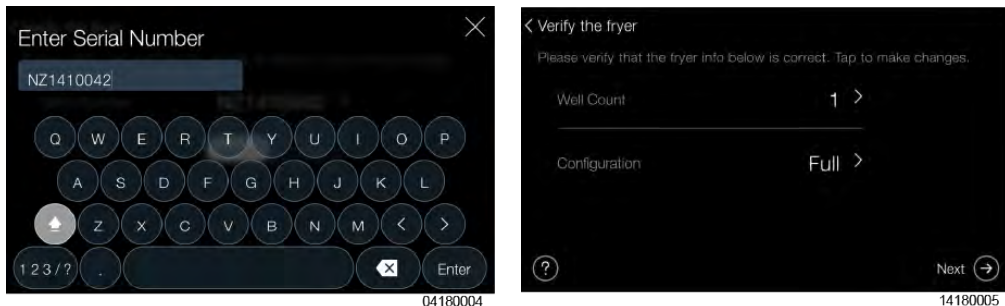

Figure 3-2

- 6) When selecting more than one vat, configure the quantity and specify whether each vat is full or split, see [Figure 3-3](#), page 13.
- 7) Tap on the display location from the control fryer setup that is being entered, see [Figure 3-3](#), page 13.

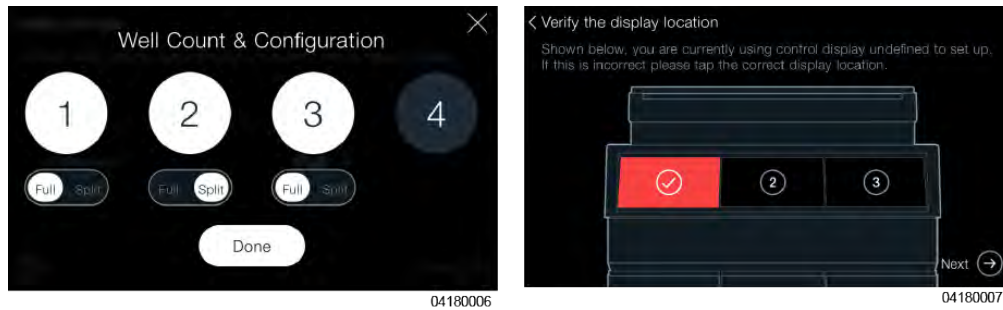

Figure 3-3

- 8) Choose your desired oil disposal method. Choose from front, rear, or cart, see [Figure 3-4](#) , page 13. **INFO:** *Front and rear options to be enabled in a future version of software.*
- 9) Use the slider to adjust the volume of the control to your desired level, see [Figure 3-4](#) , page 13.



Figure 3-4

- 10) Select how you would like food items to be displayed on the home screen. Choose from alphabetical order, most frequently cooked or most recently cooked, see [Figure 3-5](#) , page 14.
- 11) To apply the same configuration to the remaining controls, just tap the touchscreen on the remaining controls.

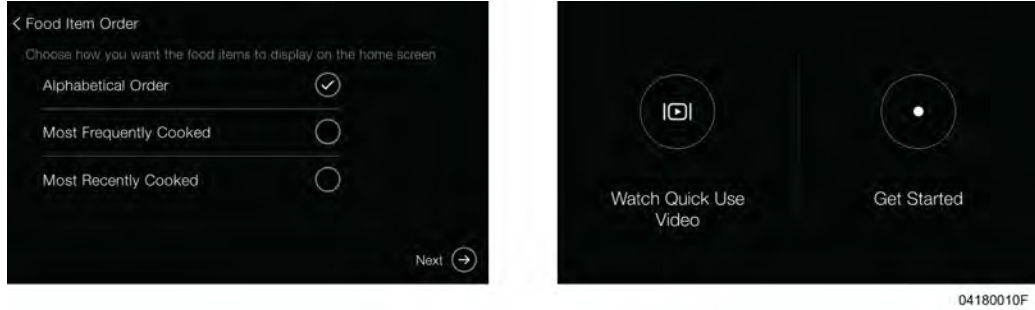

Figure 3-5

- 12) Setup is complete. Tap **Watch Quick Use Video** to view a short training of how to use the fryer, or tap **Get Started** to put the fryer into regular use mode.

Chapter 4 Basic Operation

This chapter gives you an understanding of F5 operation by walking you through a component overview and then a typical day of use.

4.1 Component overview

Get familiar with F5 components by looking over [Figure 4-1 Operating Components](#), page 15. This figure will be referenced throughout the rest of the chapter.

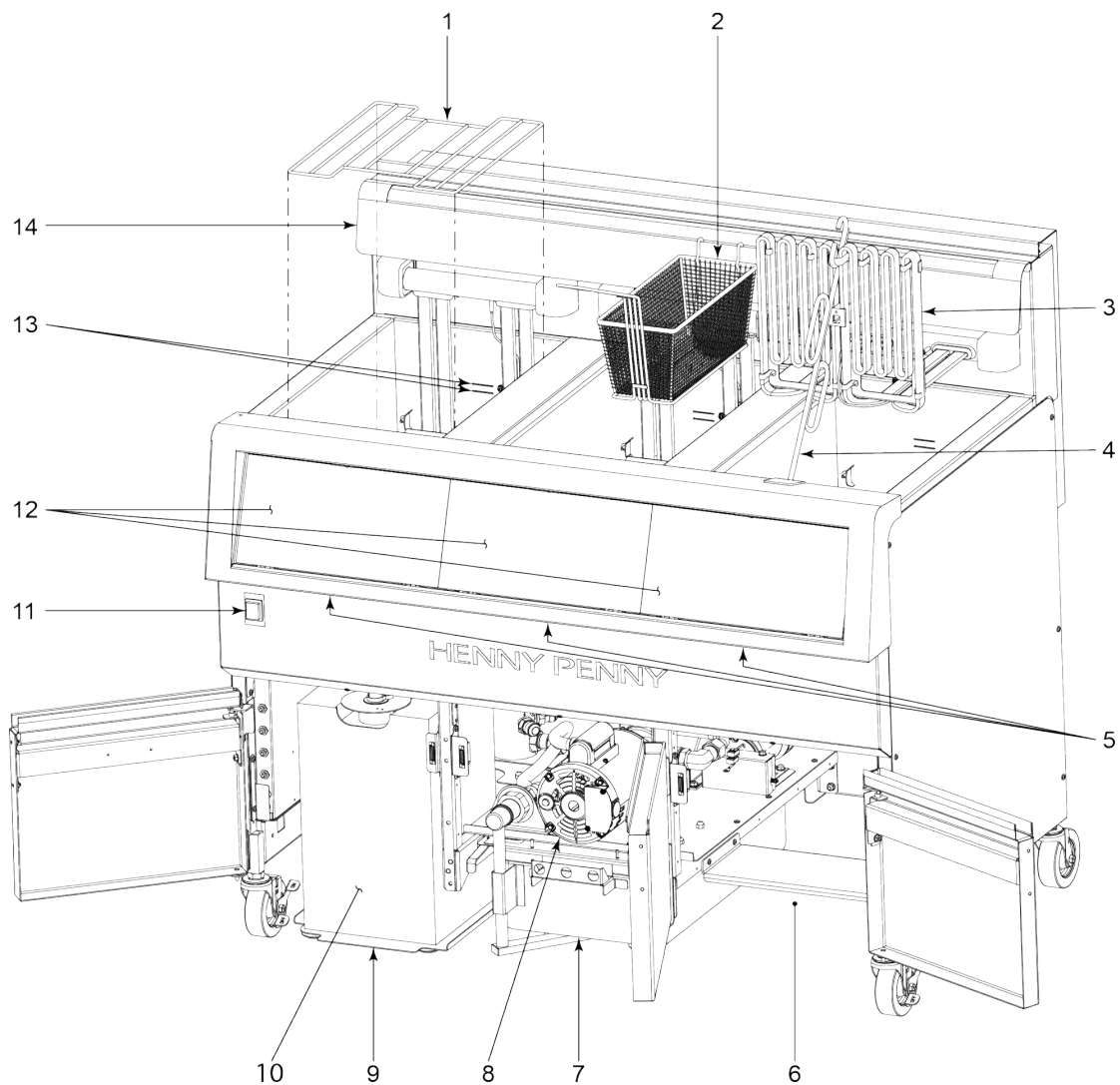

Figure 4-1 Operating Components

Table 4-1 Operating Components

Item	Name	Description
1	Basket Rest	Supports the fry basket and keeps it from rubbing the heating element.
2	Fry Basket	Used to place product into the oil for cooking.
3	Heating Element	Transfers energy to heat the oil. The heating elements tilt for easy cleaning of the vat.
4	Heating Element Lift Tool	Tool used to lift and support the heating element for easy cleaning of the vat.
5	Control Resets (not shown)	Resets a control without turning power off to the entire fryer.
6	Night Cover Storage	Area to store night covers during operation.
7	Filter Pan	Removes crumbs and oil impurities during filtration.
8	Filter Motor	Pumps oil during filtration.
9	JIB Shelf	Supports the JIB (jug-in-box).
10	JIB (not included)	Provides a supply of oil for the auto-top-off system. Fresh oil is pumped from the JIB when the oil level is low.
11	Main Power Switch	Turns on each control. Heat to each vat is turned on by each touchscreen control.
12	Touchscreen Control	Provides the interface between the user and the vat.
13	Oil Level Indicators	Indicates proper oil level when oil is at set point temperature or room temperature, see Figure 4-2 Level Indicator Lines, page 17 .
14	Basket Hanger	Supports baskets when not in use, or when draining excess oil from product.

4.2 Filling and adding oil



WARNING

- Wear Personal Protective Equipment (PPE) including heat and oil resistant gloves, apron and face shield to avoid serious burns when pouring oil into hot vat. Oil and all metal parts that are in contact with the oil are extremely hot; take care to avoid splashing, or serious burns may result. To avoid pouring oil into a hot vat, see [4.2.2 Topping off oil, page 18](#).
- The oil level must always be above the heating elements and at the proper oil level indicator on the rear of vat. Failure to follow these instructions may result in any or all of the following: fire, severe burns, or damage to the fryer.
- Solid shortening is not recommended for use in the F5. Solid shortening could cause clogging and pump failure.

4.2.1 Manually filling an empty vat

Each F5 vat has two level indicator lines as referenced in [Figure 4-2 Level Indicator Lines, page 17](#). The upper fill line (1) indicates proper oil level at set-point temperature. The lower fill line (2) indicates proper oil level at room temperature. When filling an empty vat with room temperature oil, fill to the center of the lower fill line (2). As oil heats, it expands to the upper fill line (1).

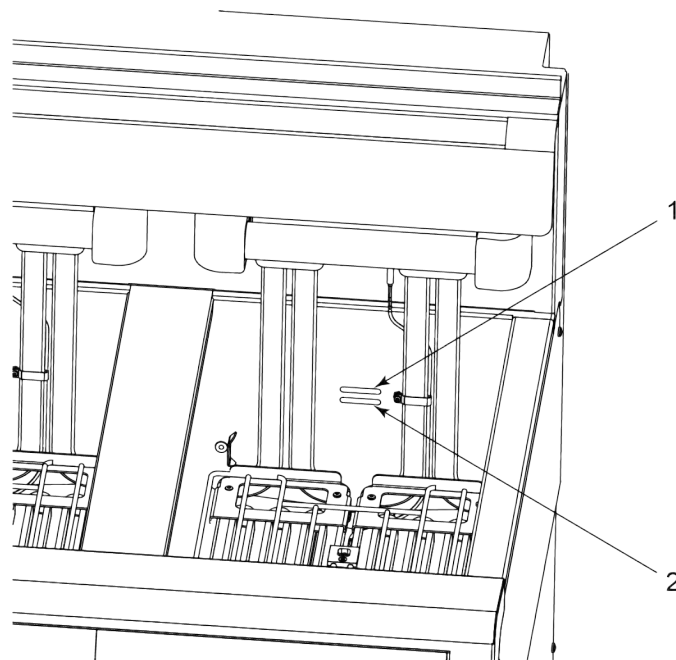

Figure 4-2 Level Indicator Lines

4.2.2 Topping off oil

The F5 fryer includes an auto-top-off feature which checks oil level and automatically replenishes oil to the fill line throughout the day from the JIB (Jug-in-Box). Auto top off activates after a few seconds in between cook cycles when no filtrations are being performed on other vats. In cases when either the JIB is empty, or when cook cycles continuously run without a pause for an extended period of time, the oil level may drop in the vat. In these cases, you can quickly pump oil from the JIB to the vat in the **Oil & Filter** menu, see [Figure 5-7 Fill Vat, page 41](#).

4.2.3 Replacing the JIB (Jug-in-Box)

When the JIB is empty, or when the message CHECK JIB appears in the display, replace the empty JIB with a new JIB, see [4.1 Component overview, page 15](#) for JIB location.

INFO: Some stores may use a BIB (Bag-in-Box) rather than a JIB. This is not a problem as the JIB tube on the F5 adjusts to fit both common JIB sizes as well as common BIB sizes.

To replace the JIB follow these instructions:

- 1) Open the door in front of the JIB. Pull the empty JIB out from under the fryer.
- 2) Remove the JIB tube.
- 3) Discard the empty JIB.
- 4) Open the new JIB and completely remove and discard the paper or foil seal.

NOTICE: Keep foil or paper seals from falling into the JIB, or blockage or damage to the JIB pump may result.

- 5) Insert the JIB tube into the new JIB until it reaches the bottom, then secure the cap down over the spout.
- 6) Slide the new JIB back onto the JIB shelf then close the door.

4.3 Turning on power and heating oil

Get ready to start your day of operation by looking at the daily fryer precheck. Links on where to find more information on the items in the precheck are included.

4.3.1 Performing the daily fryer precheck

To help eliminate interruptions during your business day, perform this daily precheck before turning on the F5:

- 1) Remove and store optional night covers, see [4.3.1.1 Storing night covers, page 19](#).
- 2) Ensure the oil level is at the correct level in each vat, see [4.2 Filling and adding oil, page 17](#).

- 3) Check the oil level in the JIB. Replace the JIB if it is empty, see [4.2.3 Replacing the JIB \(Jug-in-Box\)](#), page 18.
- 4) Ensure the drain pan is clean, dry and has been properly assembled with a new filter pad, see [Figure 4-18 Drain Pan Assembly/Disassembly](#), page 33.

4.3.1.1 Storing night covers

Prior to using a vat, remove and store night covers. On 3 and 4 vat units, night covers may be stored under the right-most vat of the fryer.

INFO: If only some vats are being used, night covers may remain on vats where the heat remains off. Night covers are an optional accessory for the F5 used to cover vats when not in use. These help reduce oil break down from oxygen, and keep airborne contaminants out of the oil. Night covers are also recommended for use during a deep clean procedure to cover adjacent vats, see [Figure 8-1 Fryer Accessories](#), page 65.

4.3.2 Powering up the F5

After performing the daily fryer precheck, turn the F5 fryer on with the main power switch. After approximately 15 seconds, the **Preheat** screen is displayed. The heat however remains off to each vat until the **Preheat** button is tapped on each touchscreen control.

4.3.3 Heating the oil

! WARNING The oil level must always be above the heating elements and at the proper oil level indicator on the rear of vat. Failure to follow these instructions may result in any or all of the following: fire, severe burns, or damage to the fryer.

You have the option to turn on some, or all of the vats on the F5. To turn on the heat to a full vat, tap the **Preheat** button (1), see [Figure 4-3](#), page 19 and the vat starts to heat. For split vat fryers, preheat the left side by tapping the left **Preheat** button (2). Preheat the right side by tapping the right **Preheat** button (3).



Figure 4-3

After tapping the **Preheat** button, heat gently pulses to avoid scorching the cool / high viscosity oil until it reaches 180°F (82°C). At 180°F (82°C) the oil viscosity decreases and heating output increases to 100%.



Figure 4-4

When oil temperature heats to 10°F (5.5°C) below setpoint, the fryer is in the ready mode, and the heat pulses to avoid temperature overshoot, see [Figure 4-5 Ready to cook, page 20](#). When you are ready to cook, tap the **Cook on Left Side** button and this will take you to the homescreen with food items active for the left basket. Tap the **Cook on Right Side** button and the homescreen displays with food items active for the right basket, see [Figure 4-6 Homescreen, page 21](#) for more information. **INFO:** The setpoint temperature of the oil is variable and can be changed in food items, see [5.3 Food Item Settings, page 41](#).



Figure 4-5 Ready to cook

4.4 Homescreen

The homescreen is the primary operating screen of the F5. From this screen, you can start timers, access oil information and enter the settings menu. There are two tabs (2) at the top of the home screen used to select whether the display is active for the left side or the right side. The left side in [Figure 4-6 Homescreen, page 21](#) is active because the left tab shows **Cook an item - Left Side**. To activate the right side, tap the **Tap to cook - Right Side** tab. The food items displayed on the homescreen apply to the active side only. Settings accessed from the homescreen apply to both sides for full vats, but some features in settings apply only to the active side for a split vat.

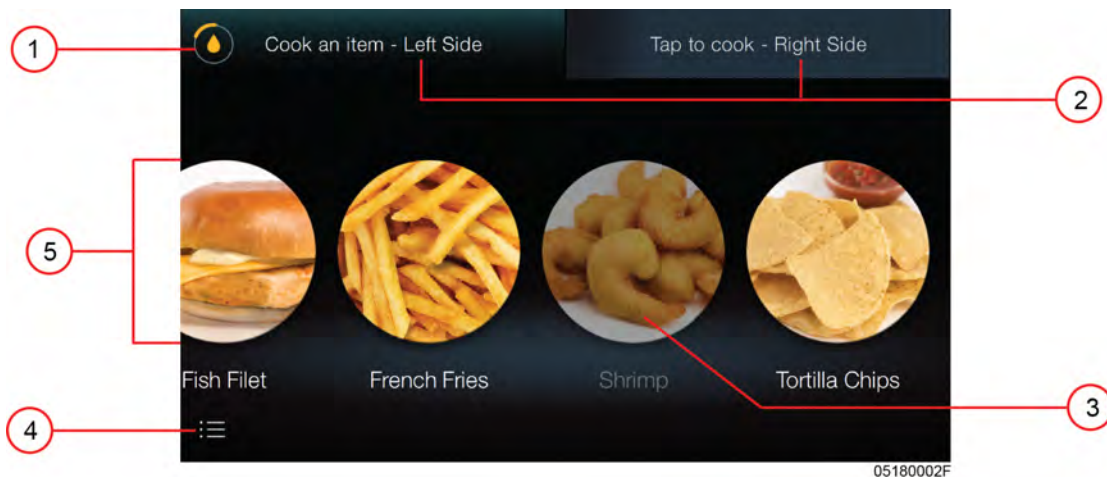

Figure 4-6 Homescreen

Table 4-2 Home Screen

Item	Name	Description
1	Oil info icon	Tap the oil info icon to view the oil information for this vat, see 4.4.1 Oil info , page 22 .
2	Left and right side tabs	Tap the tab labeled left side when starting a timer for the left basket and tap the tab labeled right side when starting a timer for the right basket.
3	Incompatible Food Item	These are grayed out food items which require an oil temperature change before cooking.
4	Settings Button	Opens the Settings panel. Set food items, access the Oil & Filter menu and more, see Chapter 5 Settings, page 35 .
5	Food Item List	Swipe left or right to view all available food items.

4.4.1 Oil info

Tap the oil info icon to get detailed information on the oil in the vat. For split vats, there are two oil info icons. The icon in the upper left displays oil information for the left vat and the icon in the upper right displays oil info for the right vat. [Figure 4-7 Oil info screen, page 22](#) provides a detailed breakdown of the oil info screen.

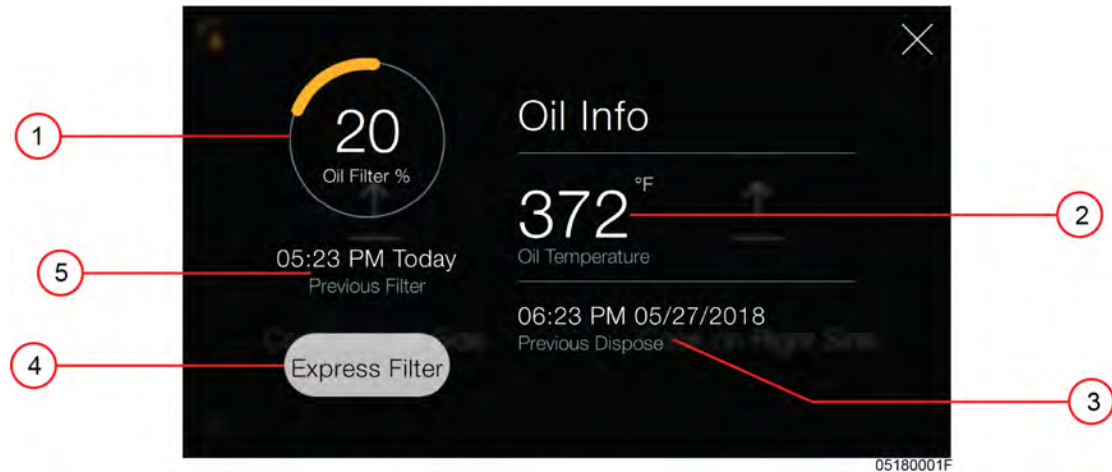

Figure 4-7 Oil info screen

Table 4-3 Oil Indicator Screen Descriptions

Item	Name	Description
1	Oil filter percentage	Oil life remaining until the next filter.
2	Oil temperature	Current oil temperature.
3	Previous dispose	Time and date of the last time the oil was disposed on this vat.
4	Express filter button	Start an express filter to reset the filter percentage to 100%.
5	Previous filter	Time and date of when the last filter was performed on this vat.

4.5 Cooking food items

Cook your food items on the F5 following these steps

- 1) Load your food item in the fry basket.
- 2) Lower the fry basket in the oil.
- 3) Start the corresponding timer on the touchscreen control.

- 4) If the timer cycle has the **Shake Alert** enabled, when the shake alert sounds, lift the basket up off of the bottom of the vat and shake the basket to loosen food items, then place the basket back into the oil.



- 5) When the timer expires and the alert sounds, lift the basket out of the oil and place it on the basket hanger to allow excess oil to drain.
- 6) Serve product, or place into a warmer to hold.

4.5.1 Single timer cooking screen

Cooking on the F5 keeps you aware not only of the time remaining for your food items, but also approximately how many more cooks remain until an express filter needs to be performed. The following is a breakdown of the single timer cooking screen.



Figure 4-8 Cooking Screen

Table 4-4 Cooking Screen

Item	Name	Description
1	Oil info	Oil filter percentage. Tap and hold to view current oil temperature.
2	Cooking Info	Time remaining along with food item name.

3	Oil filter status ring	A visual of the oil filter percentage. Solid yellow ring when oil filter percentage equals 100%. Express filter is prompted when ring disappears at 0%.
4	Cooking progress ring	This ring fills in to indicate how much of the cooking cycle has completed.

4.5.2 Full vat - starting a timer

Full vats have two timers accessible on the touchscreen control: one for the left basket and one for the right basket.

- To start a left basket timer, tap the **Left Side** tab if it is not already active, then select a food item from the homescreen and the timer begins counting down.
- To start a right basket timer, tap the **Right Side** tab if it is not already active, then select a food item from the homescreen and the timer begins counting down.

You can start one timer then press the opposite tab to start a timer for another basket.

[Figure 4-9 Dual timers, page 24](#) shows timers for the left and right baskets counting down on a full vat.

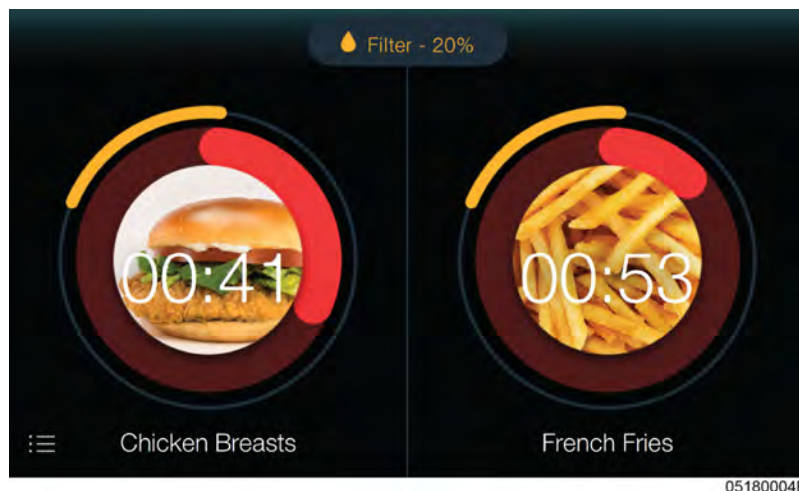

Figure 4-9 Dual timers

4.5.3 Split vat - starting a timer

Split vats have four timers accessible from the touchscreen control: two for the left vat and two for the right vat. To start a single left or right timer, tap the tab for either the left or right side then select the desired food item. To start a second timer for either the left or right split vat, tap and hold the corresponding side of the touchscreen, select a food item, and the second split vat timer starts counting down. For example, the left image shows three timers counting down. If you wanted to add another timer to the right vat, tap and hold the right side, select another food item and another timer

appears for the right side as shown in the right image of . This allows you to have 3 or 4 timers counting down at the same time which works well if you use quarter sized baskets.



Figure 4-10 3 and 4 timer operation

4.5.4 Stopping a timer

To stop a cook cycle, tap anywhere on the food item image, then tap on the stop icon, see [Figure 4-11 Stop cook Icon, page 25](#).



Figure 4-11 Stop cook Icon

4.5.5 Repeating a timer

After a cook cycle has been completed a repeat cook icon will appear over the previously cooked product on the display, see [Figure 4-12 Repeat Cook Icon, page 26](#). To repeat a cook cycle, tap the repeat cook icon on the food item image. To select a different food item, swipe left or right and your available food items display.



Figure 4-12 Repeat Cook Icon

4.5.6 Incompatible food items

These are grayed out food items which require an oil temperature change before cooking, see [Figure 4-6 Homescreen, page 21](#). Tapping on an incompatible food item opens a display which lets you know that either the oil needs to heat or cool down to a new setpoint.

4.6 Oil Management

As frying oil deteriorates, it produces by-products that impact the flavor and texture of the food. There is a “sweet spot” to oil where the oil degradation process reaches an optimum state. This sweet spot can be extended through proper oil management. This section provides an understanding of the oil management features on the F5. Some of these features are explained in this section and some are cross referenced with links to other sections. All of these features help you improve the quality and consistency of product while reducing your oil costs.

1. **Preheat mode** - Protects oil by pulsing the heat on and off until the oil temperature reaches 180°F (82°C), see [4.3.3 Heating the oil, page 19](#).
2. **Express Filter** - Removes frying by-products, such as crumb accumulation, which can degrade your oil. During normal operation and after a certain number of cooks, team members are prompted to perform an express filter. The express filter process requires the team member to skim the vat, but then after that, the filtration is fully automated. The F5 completes the entire express filter process, including bringing the oil back to set temperature, in as little as 3 minutes. Cooking doesn't have to be stopped during an express filter, because as one vat is being filtered, the other vats can still be used for cooking, see [4.6.1 Express Filter, page 27](#).

3. **Automatic Top Off** - Monitors oil levels in each vat and automatically replenishes oil from JIB. Automatic top off extends the sweet spot of your oil by adding fresh oil to each vat on a regular basis, see [4.2 Filling and adding oil, page 17](#).

4.6.1 Express Filter

Throughout the day as food items are cooked, crumbs and other contaminants accumulate in the vat and periodically need to get removed with the automated express filter feature. Each food item in the menu includes a setting of how many of that item can be cooked before an express filter is required, see [5.3.3 Create Food Item, page 44](#). As an example, products which produce more crumbs during cooking typically require a lower number for this setting, and products which produce fewer crumbs typically have a higher number for this setting. You may find that 15 cooks between express filters works well for fries, while a product with more breading such as chicken strips may require 8 cooks between express filters.

The F5 touchscreen control lets team members know approximately how many cooks remain before the next express filter both from the oil filter percentage and also from the yellow filter status ring. The filter percentage starts at 100% for each vat, and as product is cooked, this percentage decreases. When the filter percentage reaches 0% in any vat, an express filter prompt appears indicating that it is time to filter, see the left image in [Figure 4-13 , page 27](#). When performed, the F5 completes the entire express filter process, including bringing the oil back to set temperature, in 3 minutes or less with a properly maintained filter pan. As one vat is being filtered, the other vats can still be used for cooking. The express filter process is described in the following steps:

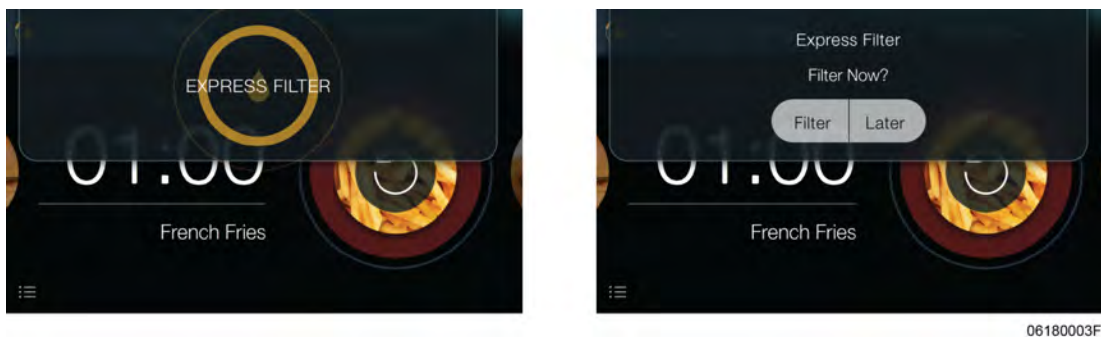

Figure 4-13

- 1) Tap express filter then select **Filter** to filter now, or select **Later** to delay filtration and continue cooking, right image [Figure 4-13 , page 27](#).



INFO: When selecting **Later**, an alert icon displays next to the oil info icon and the express filter prompt displays after each additional cook until an express filter is performed.

- 2) **Skim vat** - Use a skimming tool (not provided with the F5) to skim the top of the oil to remove floating crumbs and product from the surface of the oil, and then confirm by tapping **OK**, see (1) in [Figure 4-14](#) , page 28.

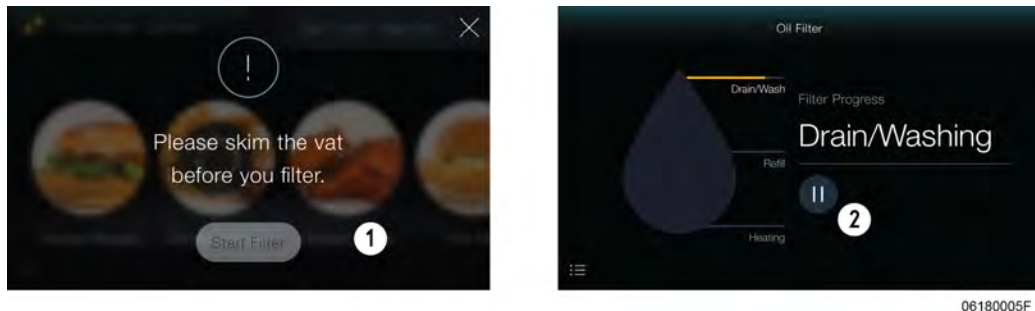

Figure 4-14

INFO: See [Figure 8-1 Fryer Accessories](#), page 65.

- 3) **Drain / Wash** - Oil drains to the filter pan and pumps to wash crumbs down the open drain, see (2) in [Figure 4-14](#) , page 28.
- 4) **Refill** - Oil continues to pump and the drain valve closes to allow the oil to refill the vat, see (1) [Figure 4-15](#) , page 28.

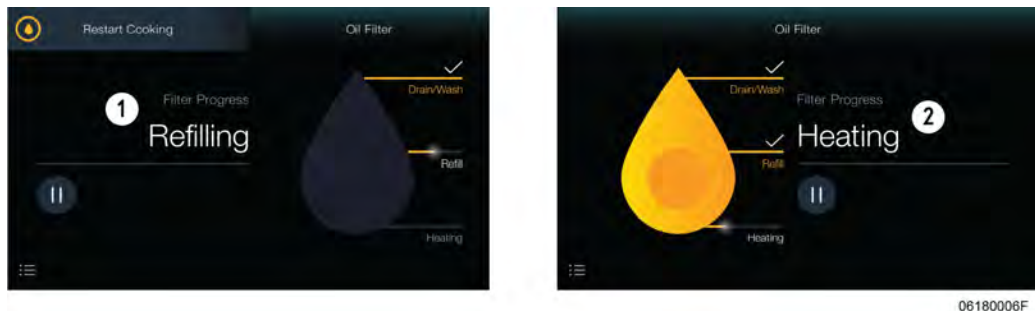

Figure 4-15

- 5) **Heating** - As the vat fills, the heat turns on to raise the oil temperature back to frying temperature, see (2) [Figure 4-15](#) , page 28.
- 6) Once heated, **Filter Complete** displays followed by the cooking screen, see (1) [Figure 4-16](#) , page 29.

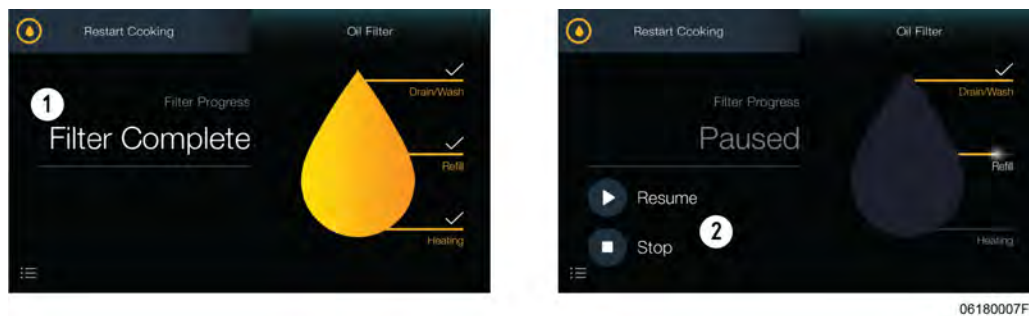

Figure 4-16

Team members have the option to pause each step, followed by either resuming the step or stopping the express filter, see (2) [Figure 4-16](#) , page 29.

4.6.2 Managing express filters during busy periods

Team members have the option to perform an early express filter during slow frying periods to make sure an express filter doesn't interrupt a busy frying period or rush. For example, if there is only 10% oil filter status remaining (1 or 2 cooks remaining) during a slow frying period, the team member can start an express filter early by tapping on the **Oil Info Icon**, then tapping **Express Filter**. Alternatively, an express filter can also be started from the **Settings > Oil and Filter** menu [5.2.1 Express filter](#) , page 37. Anytime an express filter is completed, the oil filter status returns to 100% and team members are ready for the next busy period.

Best Practice: Encourage team members to **Filter** when prompted and to manage filtrations between busy periods. This helps extend the sweet spot of your oil and maximizes your oil life.

4.7 Shutting down the F5

End of day shutdown ensures a good start for team members the next day.

4.7.1 F5 shutdown checklist

- 1) Perform a **Daily Filter** on each vat.
- 2) Remove, clean, and re-assemble the filter pan with a new filter.
- 3) Remove and clean the basket hanger, clean the area behind the basket hanger, and re-install.
- 4) Turn off the main power switch.
- 5) Wipe down the touchscreen controls.

- 6) Wipe down the exterior of the fryer including the side panels, doors, and area around vats.
- 7) Place a night cover over each vat (if equipped), see [Figure 8-1 Fryer Accessories](#), page 65.

4.7.2 Filter pan assembly

The filter pan removes crumb accumulation and impurities from the oil during filtration. Throughout the day if filtration slows, it may be necessary to empty the crumb basket and to scrape smaller crumbs from the filter. At shutdown, remove and clean the filter pan assembly to ensure the drain pan is clean for the next day. Typically this would be done after the daily filter is completed on all vats. Filter pan shutdown steps are as follows:

4.7.2.1 Filter pan maintenance throughout the day



WARNING

- **Burn risk! Do not move the fryer or filter drain pan while containing hot oil. Personal injury or serious burns can result from splashing hot oil.**
- **Burn Risk! The filter pan may be hot. To avoid burns from hot oil and hot surfaces, use approved safety equipment including an apron, face shield, and gloves before removing the filter pan.**

Filter pan maintenance may need to be performed periodically throughout the day if oil starts to pump slowly during express filters. Perform the following maintenance steps to increase oil flow during filtration:

- 1) Open the door in front of the filter pan.
- 2) Remove the filter pan by pulling it out from under the fryer. This separates the male (1) and female (2) sections of the filter pan connection, see [Figure 4-17 Drain Pan Remove/Install](#), page 31.
- 3) Remove the filter pan lid and the crumb basket. Discard the crumbs in the crumb basket, see [Figure 4-18 Drain Pan Assembly/Disassembly](#), page 33.
- 4) Using a pot scraper or spatula, gently scrape finer crumbs off of the top of the filter and discard.
- 5) Replace the crumb basket and the filter pan lid.
- 6) Reinstall the filter pan under the fryer and close the door.

4.7.2.2 Cleaning the filter pan



WARNING

- Burn risk! Do not move the fryer or filter drain pan while containing hot oil. Personal injury or serious burns can result from splashing hot oil.
 - Burn Risk! The filter pan may be hot. To avoid burns from hot oil and hot surfaces, use approved safety equipment including an apron, face shield, and gloves before removing the filter pan.
- 1) Open the door in front of the filter pan. See [1.2 Model configuration and identification, page 1](#) for filter pan location.
 - 2) Remove the filter pan by pulling it out from under the fryer. This separates the male (1) and female (2) sections of the filter pan connection, see [Figure 4-17 Drain Pan Remove/Install, page 31](#).

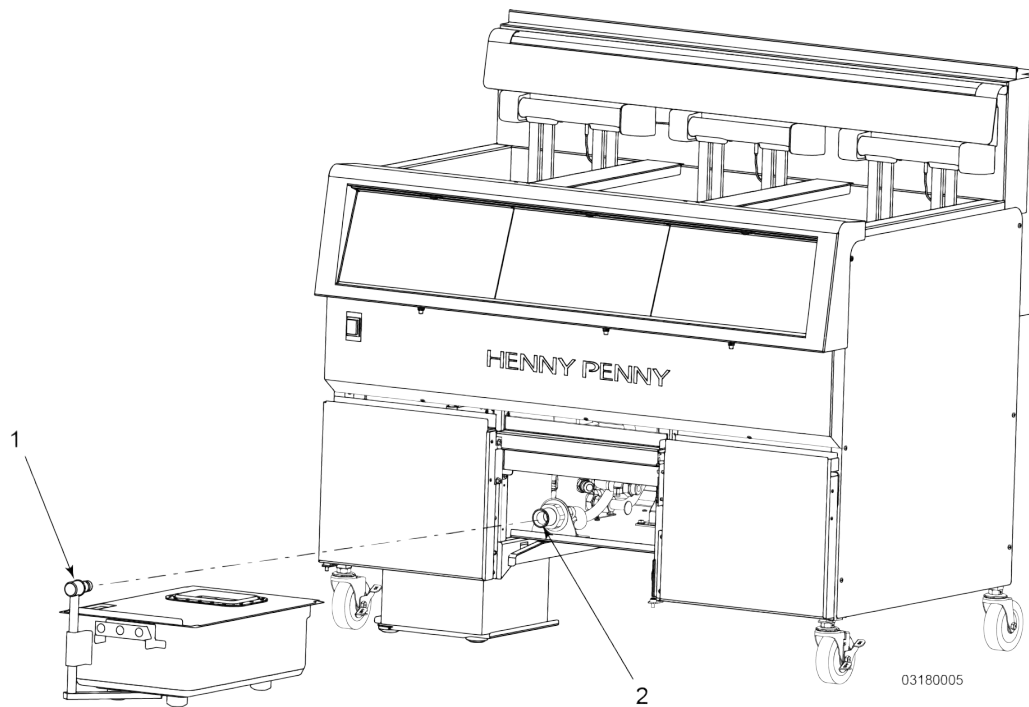

Figure 4-17 Drain Pan Remove/Install

- 3) Close the filter pan door.
- 4) Disassemble the filter pan, empty the crumb basket and discard the filter.
- 5) Wash and dry all components of the filter pan.
- 6) Reassemble the filter pan in the following order:

- a. Place the filter screen (5) in the drain pan base (4), see [Figure 4-18 Drain Pan Assembly/Disassembly, page 33](#).
- b. Place filter paper (3) on top of the filter screen (5).
- c. Place drain pan weight (6) on top of the filter paper (3).
- d. Place crumb catcher (2) on top of the drain pan weight (6).
- e. Place drain pan lid (1) on top of the drain pan base (4).

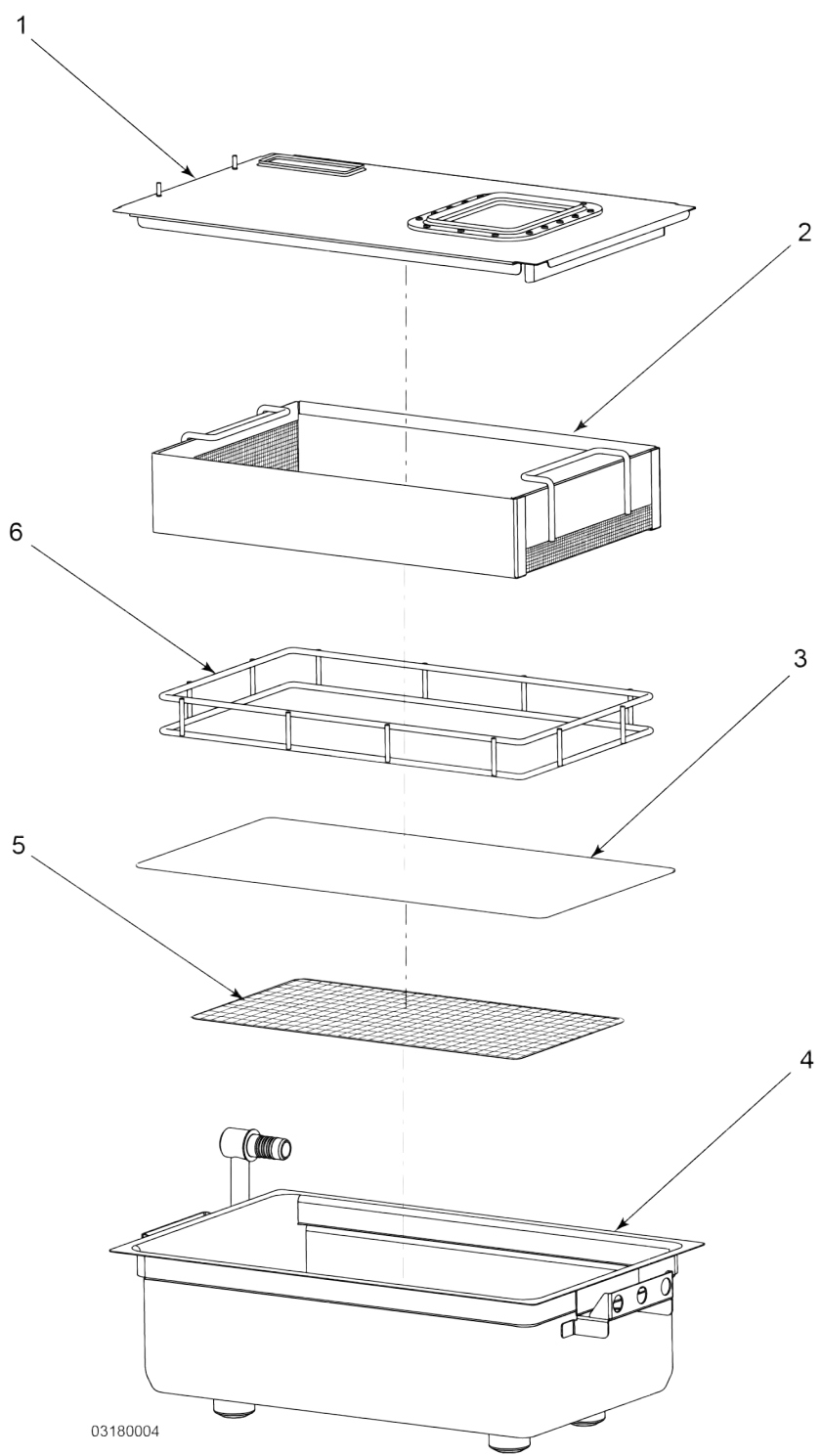

Figure 4-18 Drain Pan Assembly/Disassembly

- 7) Open the filter pan door.
- 8) Push the filter pan into the fryer until firmly seated.
- 9) Close the filter pan door.

4.7.3 Cleaning the basket hanger

Slide the basket hanger up and then pull toward you to remove, see [Figure 4-1 Operating Components, page 15](#). Clean both the basket hanger and the area behind the basket hanger, then re-install.

4.7.4 Turning off the F5

At the end of the day, turn the main power switch to the off position. For the main power switch location, see [Figure 4-1 Operating Components, page 15](#).

INFO: Heat to each vat shuts down when turning off the main power switch as well as each touchscreen control.

Chapter 5 Settings

The settings tab is located in the lower left corner of the home screen, see [4.4 Homescreen, page 21](#) for location. Settings lets you do things like add new food items, perform filtration tasks, shutdown the heat to each vat and more. Swipe up or down on the settings menu to see all available options. See [Figure 5-1 Settings Screen, page 35](#), **Shutdown Vat** menu item not shown.

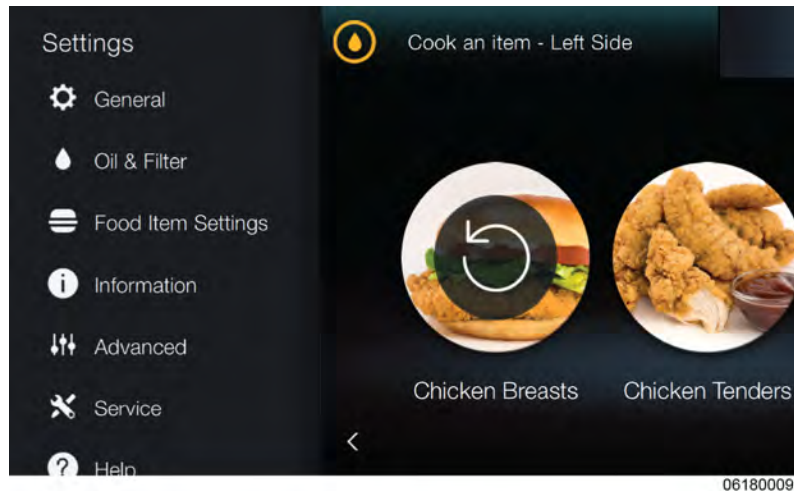

Figure 5-1 Settings Screen

More detailed information about the options of the settings menu are as follows:

- [5.1 General, page 35](#)
- [5.2 Oil & Filter, page 36](#)
- [5.3 Food Item Settings, page 41](#)
- [5.4 Information, page 48](#)
- [5.5 Advanced, page 48](#)
- [5.6 Service, page 49](#)
- [5.7 Help, page 49](#)
- [5.8 Shutdown Vat, page 49](#)

5.1 General

The following section explains the basics settings for the F5.

5.1.1 Volume

Move the slider to a volume level of your choosing. Moving the slider to the right increases the volume to each control. Moving the slider to the left decreases the volume to each control.

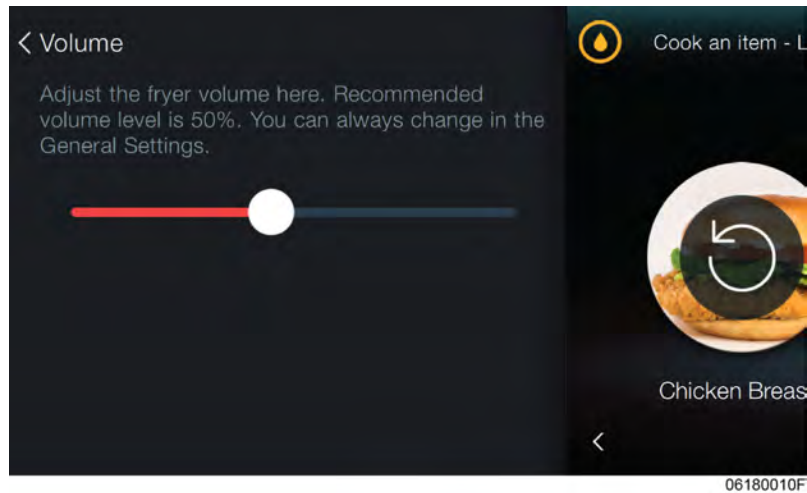

Figure 5-2 Speaker Volume

5.2 Oil & Filter

The **Oil & Filter** menu lists all of oil filtering, oil fill, and oil dispose options. Tap the desired option, then follow the prompts on the screen to the task. The **Oil & Filter** menu options are described in this section, see [Figure 5-3 Oil & Filter Screen, page 36](#).

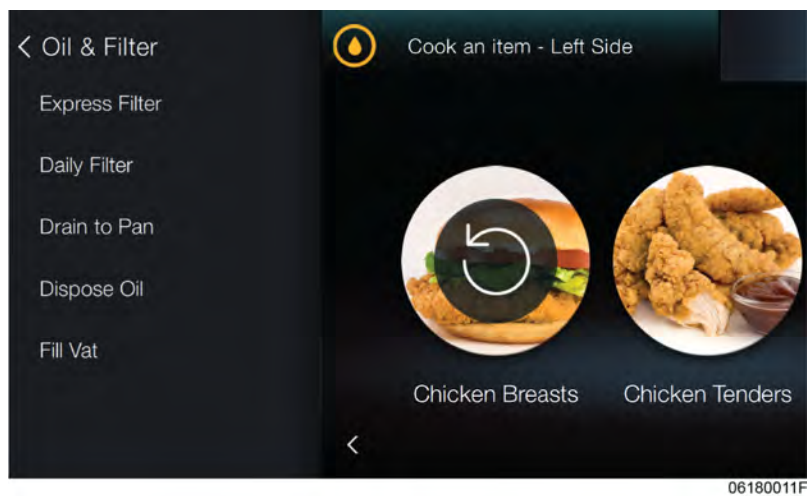

Figure 5-3 Oil & Filter Screen

More detailed information about the Oil & Filter menu options can be found in:

- [5.2.1 Express filter](#), page 37
- [5.2.2 Daily filter](#), page 37
- [5.2.3 Drain to Pan](#), page 38
- [5.2.4 Dispose Oil](#), page 39
- [5.2.5 Fill Vat](#), page 40

5.2.1 Express filter

See [4.6.1 Express Filter](#), page 27 for complete information on express filter. This **Express Filter** option in the **Oil & Filter** menu is used during slow frying periods when the oil filter percentage is low, to prepare for busy frying periods. Any time an express filter is performed, even when the filter percentage is not at 0%, the oil filter percentage returns back to 100%.

5.2.2 Daily filter



WARNING

Burn Risk! To avoid burns from hot oil and hot surfaces, use approved safety equipment including an apron, face shield, and gloves before starting the filtering procedure.

The Daily Filter is similar to an Express Filter however it is a more thorough cleaning of the vat than the Express filter. It adds steps to scrub the vat and to rinse the vat. It also includes options to repeat the wash cycle. This procedure must be performed once per day to remove build up and debris from the sides and bottom of the vat. The daily filter can be performed during any non-frying periods, however it is typically performed end of day. The steps of the daily filter are explained below:

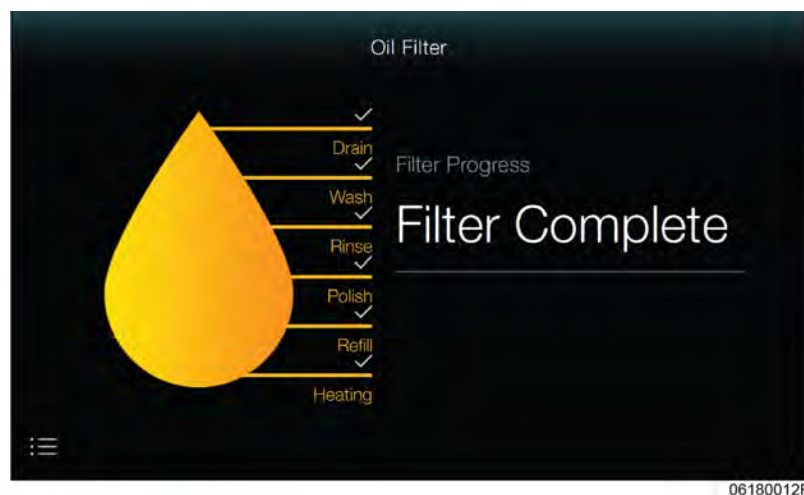

Figure 5-4 Daily Filter

- 1) Put on Personal Protective Equipment (PPE).

WARNING! Burn Risk! To avoid burns from hot oil and hot surfaces, use approved safety equipment including an apron, face shield, and gloves before starting the filtering procedure.

- 2) From the **Oil & Filter** menu, tap **Daily Filter** then skim the vat. Once skimming is complete, tap **Start Filter**.
- 3) **Drain** - Oil drains to the filter pan. After oil drains, the prompt **Scrub Vat** is displayed. Raise heating elements with the element lift tool to scrub the sides and bottom of the vat with the L-tipped brush and the gong brush, see [Table 8-1 Fryer Accessories, page 66](#). Lower the heating elements and tap the start button once scrubbing is complete to continue.

NOTICE: Use brushes only to scrub the heating element and sides and bottom of the vat, otherwise damage may occur to the heating element and / or vat.

- 4) **Wash** - Oil pumps to wash the crumbs and debris down the drain. When the wash completes, **Repeat Wash** to wash again, or **Start Rinse** to continue.
- 5) **Rinse** - The drain valve closes and oil fills and drains from the vat to rinse. The drain opens again to drain the oil. Tap **Repeat Rinse** to rinse again or **Start Polish** to continue.

INFO: The L-tipped brush and the gong brush may be used to loosen crumbs and debris during the rinse step.

- 6) **Polish** - The polish cycle is like an extended wash cycle. The polish cycle by default is set to 5 minutes. During this time, oil is pumped into the vat while the drain valve remains open. This extended filtration polishes oil by removing small particles and contaminates as the oil continuously cycles through the filter. After 5 minutes, the Refill step automatically begins.
- 7) **Refill**- The drain valve closes and oil fills the vat. Once complete, select **Start Heat** to continue to the next step, or **Skip Heat** to keep the vat off.
- 8) **Heating** - The temperature of the oil is heated back to set point temperature. The cooking screen is displayed.

The daily filter touch screen display is shown in [Figure 5-4 Daily Filter, page 37](#). When the filter is complete there will be a checkmark next to each stage showing it has been completed.

5.2.3 Drain to Pan

The Drain to Pan option allows the user to drain the oil from the vat into the drain pan. The oil then stays in the pan until the user selects an option (input) to fill. This step is useful to remove something that has fallen into the vat, or if service is necessary for one of the components in the vat. Tap **DRAIN** and the drain opens. Tap **COMPLETE** once oil has drained. When ready to pump oil back to the vat, **Fill Vat From** is displayed and the possible selections are as follows: **Drain Pan, Bulk, JIB, Manual Fill**. Always tap **Drain Pan** to ensure the drain pan is empty. This step is not intended to be used to dispose oil, see [Figure 5-6 Dispose Oil, page 40](#) to properly dispose oil.

Once **Drain Pan** is selected, tap and hold **FILL** until the all of the oil pumps from the drain pan then tap **DONE**.

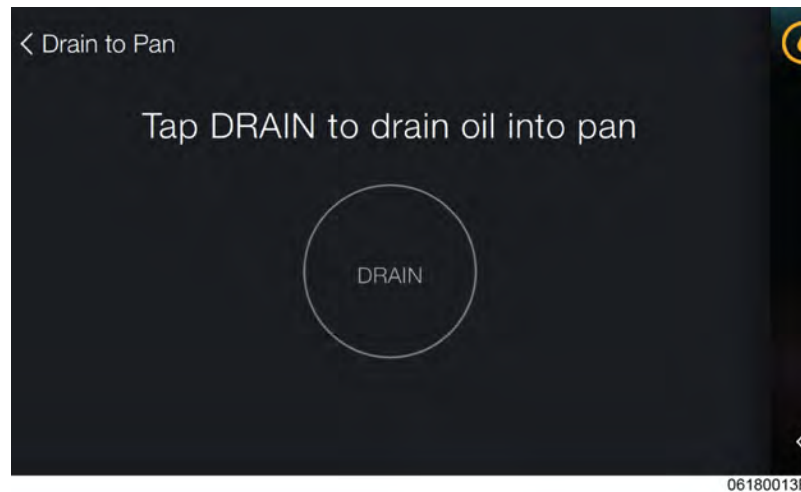

Figure 5-5 Drain to Pan

5.2.4 Dispose Oil



WARNING

- **Burn risk! Do not move the fryer or filter drain pan while containing hot oil. Personal injury or serious burns can result from splashing hot oil.**
- **Burn Risk! To avoid burns from hot oil and hot surfaces, use approved safety equipment including an apron, face shield, and gloves before starting the dispose procedure.**

The **Dispose Oil** provides two options to dispose of oil in the vat. Tap the desired disposal method icon and follow the prompts to dispose the oil. The two disposal options are described below:

- **Drain Pan** - Oil is drained to the pan and then removed from the pan with a external suction system.
WARNING! Burn risk! Do not move the fryer or filter drain pan while containing hot oil. Personal injury or serious burns can result from splashing hot oil.
- **Cart** - Tap **Cart** then remove the empty drain pan. Open the lid on the ODS (available separately) and insert it under the fryer ensuring that the drain spout aligns with the opening on the ODS. Tap **Ready** once installed. Once oil has finished draining, tap **Complete**. Roll the ODS out from under the fryer. Close and latch the lid to transport. Select from **Drain Pan**, **Bulk**, or **Manual Fill** to refill the vat, see [Figure 5-7 Fill Vat, page 41](#) for an understanding of fill indicators. Select **Done** when finished.

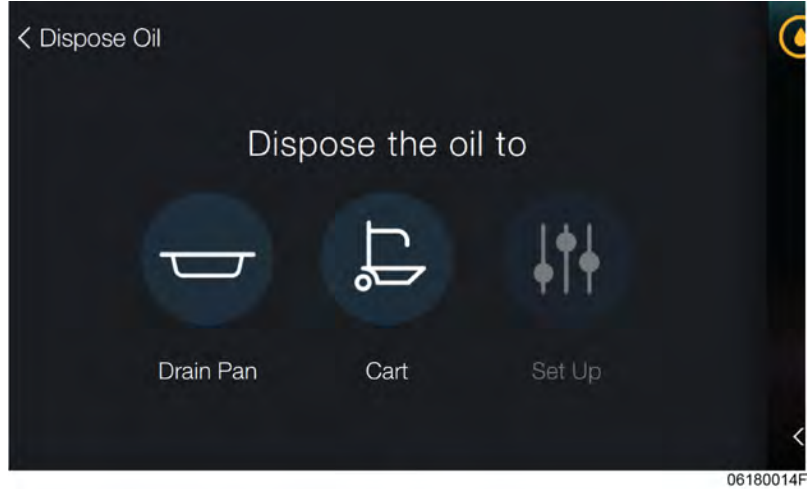

Figure 5-6 Dispose Oil

5.2.5 Fill Vat

The Fill Vat option provides four options to fill the vat with oil, see [Figure 5-7 Fill Vat, page 41](#). Tap the desired fill method icon and follow the prompts to fill the vat with oil. The four fill options are as follows:

- **Drain Pan** - Tap **Drain Pan** then tap and hold **Fill** until the drain pan is empty. Select **Done** when finished.
- **Bulk** - Option available in a future software release.
- **JIB** - Tap **JIB** then tap and hold **Fill** to fill the vat from the JIB, see [Figure 5-7 Fill Vat, page 41](#) for an understanding of fill indicators. Select **Done** when finished. **INFO:** To save time, use the **Manual Fill** option to fill an empty vat with oil rather than the slower option to fill the entire vat from the JIB.
- **Manual Fill** - Manually pour oil from a JIB into the vat. Tap **Done** when filled, see [Figure 5-7 Fill Vat, page 41](#) for an understanding of fill indicators.

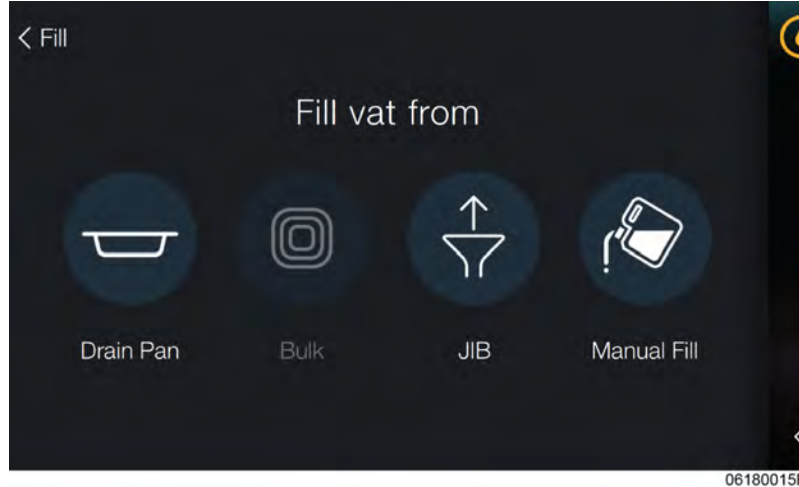

Figure 5-7 Fill Vat

5.3 Food Item Settings

Food Item Settings allow you to create, edit and re-arrange your food items. Tap **Food Item Settings**, type the code 1234 and the following three options display:

- **Manage Food Items**
- **Food Item Order**
- **Create Food Item**

Each of these options is described in detail as follows:

5.3.1 Manage Food Items

Manage food items allows you to copy, edit, or delete your food items. Tap **Manage Food Items** and your food items are displayed. Swipe left or right to view all food items as only three appear on the display at any given time. If the hidden icon is displayed on any of your food items, this item will not display when normal cooking resumes. Tap on a food item to edit, copy, or delete it, see [Figure 5-8 Managing food items, page 42](#).

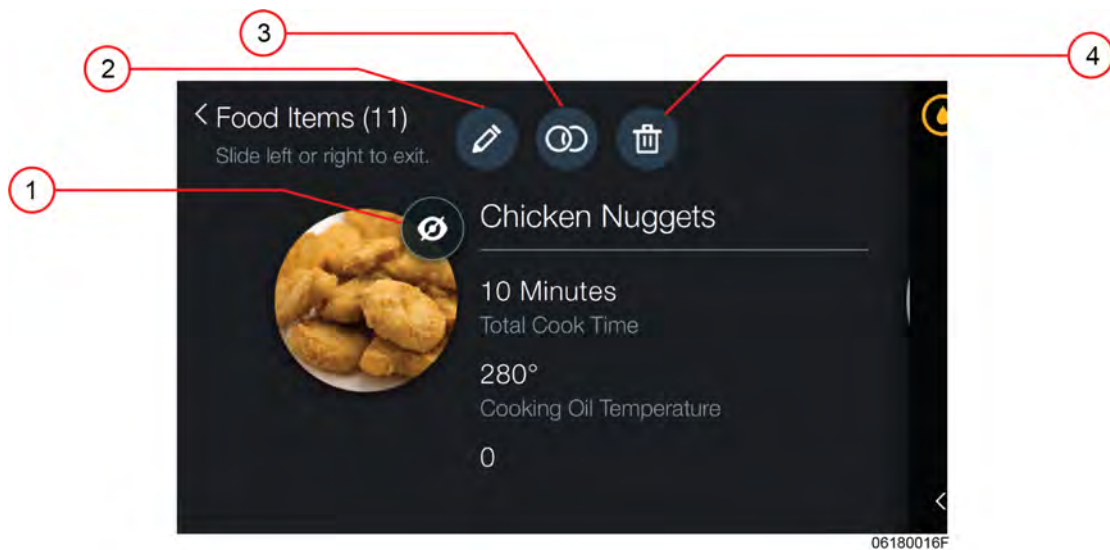

Figure 5-8 Managing food items

Table 5-1 Managing food items

Item	Description
1	Hidden icon - Food items are not available on the homescreen when hidden.
2	Edit icon - Tap to edit an existing food item.
3	Copy icon - Tap to copy and existing food item.
4	Delete icon - Tap to delete an existing food item.

5.3.1.1 Editing a food item

Editing a food item allows you to change one setting or multiple settings of an existing food item. Use the following steps to edit a food item:

- 1) Select **Settings > Food Item Settings**, type the code 1,2,3,4 and then select **Manage Food Items**. Select the food item you would like to edit, then tap the edit icon, see [Figure 5-8 Managing food items, page 42](#) for a description of icons.
- 2) Tap the setting you would like to edit, see [5.3.3 Create Food Item, page 44](#) for an understanding of all food item settings.
- 3) Tap **Done** after each setting change. Repeat the previous step if you want to change another setting.
- 4) Tap **Save** to save your changes.

5.3.1.2 Copying a food item

Copying a food item is a simple way to create a food item when the settings of the new food item are similar to the settings of an existing food item. Select **Settings > Food Item Settings**, type the code 1,2,3,4 and then select **Manage Food Items**. Tap a food item, then tap the copy icon. A copy of the food item appears with the same name; however, a number “2” appears after the name to let you know which of the food items is the copy. To modify the copy, tap on it, then tap the edit icon.

5.3.1.3 Deleting a food item

Deleting a food item completely removes the food item from the memory of the control. There are two methods you can use to delete food items, deleting a single item or deleting multiple food items at once.

- **Deleting a single food item** - Select **Settings > Food Item Settings**, type the code 1,2,3,4 and then select **Manage Food Items**. Tap a food item then tap the delete icon, see [Figure 5-8 Managing food items, page 42](#) for a description of icons. **Are you sure you want to delete? Cancel or Delete** is displayed. Tap **Delete** to completely remove the food item from the control. Tap **Cancel** to go back to the previous step.
- **Deleting multiple food items at once**- Starting from the Food Item menu select **Settings > Manage Food Items**. Tap the delete icon in the lower left corner, then select all of the food items you would like to delete. A checkmark appears on each item you have selected. Once you have made your selections, tap the delete icon in the upper left corner, see [Figure 5-8 Managing food items, page 42](#) for a description of icons. **Are you sure you want to delete? Cancel or Delete** is displayed. Tap **Delete** to completely remove the food item from the control. Tap **cancel** to go back to the previous step.

5.3.2 Food Item Order

Choose how you want the food items to display on the home screen. Select one of the following three options from [Figure 5-9 Food Item Order, page 44](#):

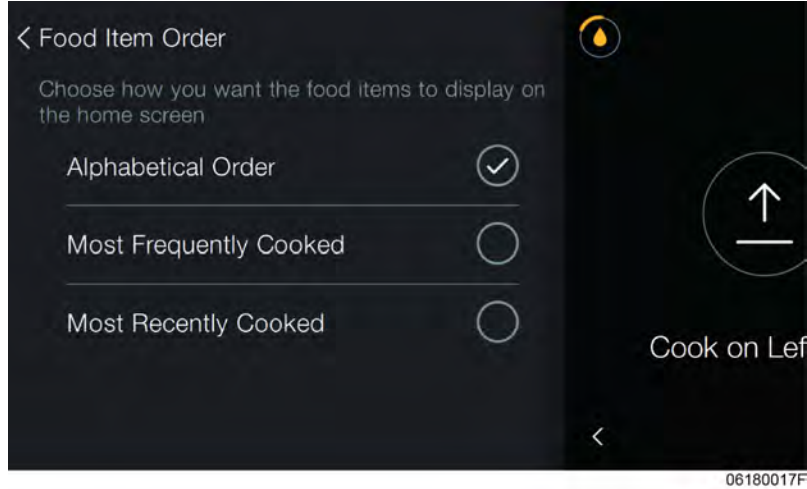

Figure 5-9 Food Item Order

Table 5-2 Food Item Order

Food Item Order	Description
Alphabetical Order	Food items display alphabetically from left to right.
Most Frequently Cooked	Food items are displayed with the most frequently cooked items to least frequently cooked items from left to right.
Most Recently Cooked	Food items are displayed with the most recently cooked items on the left and the item that hasn't been cooked for a while on the right.

5.3.3 Create Food Item

Create new food items to that are stored in the controller memory then hide or unhide items. The following steps are the basic steps needed to create a new item and get you cooking. For a listing of the advanced steps, see [5.3.3.1 Advanced Cooking Parameters](#), page 47:

1. **Cooking Time** - Tap **Select**. Swipe up or down to select minutes and seconds, see [Figure 5-10](#), page 45 (1) and (2). Tap **Done** to continue.

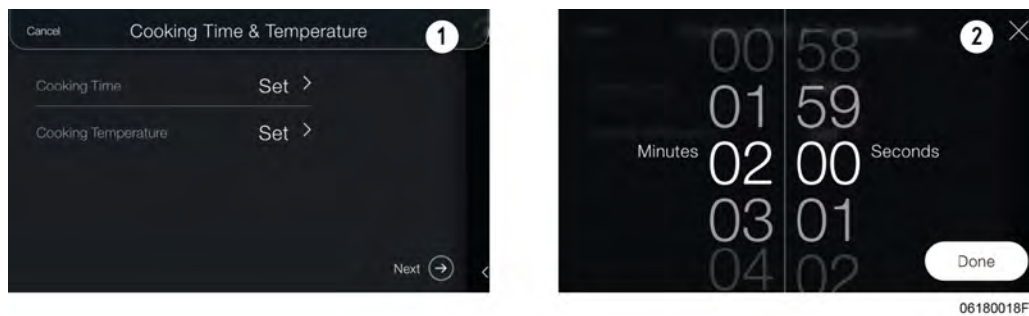

Figure 5-10

2. **Cooking Temperature** - Tap **Select**. Swipe up or down to select the cooking temperature (1) [Figure 5-11](#) , [page 45](#). Tap **Done**, and then tap **Next** to continue.
INFO: If the cooking temperature of this food item differs from other products on the home screen, this food item will be grayed out, indicating that a preheat or cool down of the oil is necessary, prior to starting the cooking cycle.

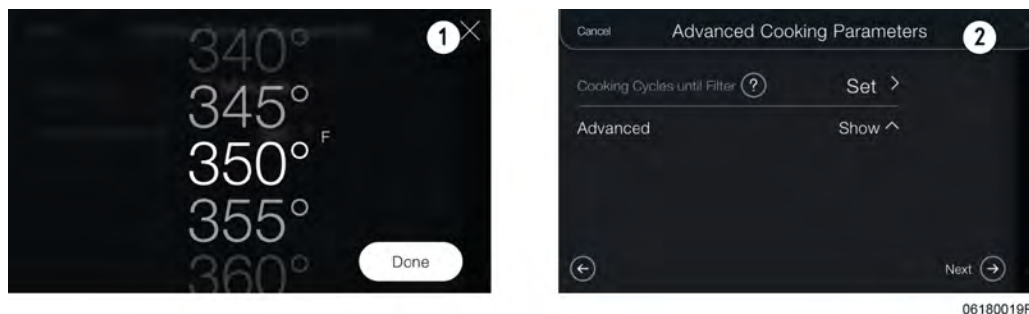

Figure 5-11

3. **Cooking Cycles until Filter** - Determines how many of this food item can be cooked before an express filter prompt is displayed (2) [Figure 5-11](#) , [page 45](#). Tap **Set**, and then swipe up or down to select cooking cycles until filter. Tap **Done** to continue.
INFO: If you are unsure about where to set this setting, start around 15 cook cycles until filter for a product with a smaller amount of crumb fall off like french fries and 6 cook cycles for a product with a larger amount of crumb fall off like fresh breaded chicken strips. Monitor crumb build up during express filters and edit this setting as necessary.
4. **Advanced Settings** - See [5.3.3.1 Advanced Cooking Parameters](#), [page 47](#) for details.
5. **Shake Alert** - The shake alert provides an alarm to remind team members to lift the basket and shake to separate the food item within the fry basket. To add a shake alert, tap the toggle switch on the display to reveal the shake alert settings, see (1) in [Figure 5-12](#) , [page 46](#). Tap **Set** next to **Activate Alert At**. Swipe up or down to select the time remaining on the timer when the alert sounds. For example, if you have a 3:00 cook cycle and want to set a shake alarm to sound after 30 seconds, set the Activate Alert

time to 2:30. Tap **Done** to continue. To enter a second shake alert, tap the toggle switch on the display next to **Shake Alert 2** to reveal the shake alert settings. Refer to the instructions for Shake Alert to add a time. Tap **Next** to continue, or the left arrow to go to the previous step.

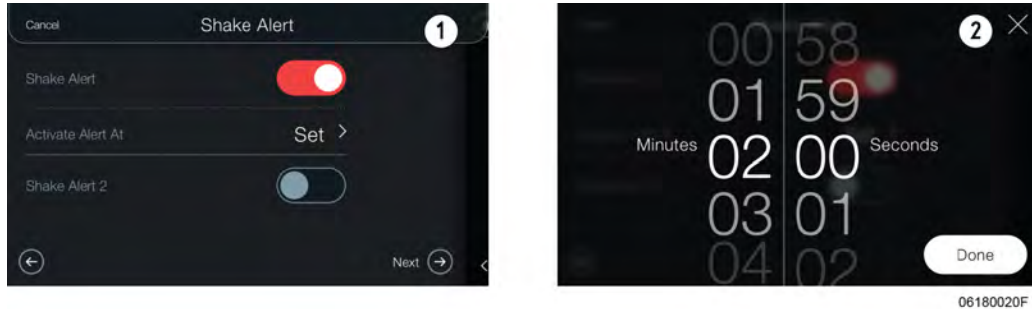

Figure 5-12

- Food Image** - This step allows you to select a food image for the food item. Choose from image lets you select an existing image from the control. Download an image lets you select an image you provide on a USB drive, see (1) in [Figure 5-13 , page 46](#). To **Choose from image**, tap the icon above the text Choose from image, then Swipe up or down to locate your desired image from the available images, see (2) in [Figure 5-13 , page 46](#). Tap the image to select it, then tap **OK**. To **Download an image**, tap the icon above the text Download an Image, then insert your USB drive, and then tap **OK** to confirm. Swipe up or down to locate your desired image from your USB drive. Tap the image to select it, and then tap **OK**. Tap **Next** to continue, or tap **Change the image** to go back and select another image.

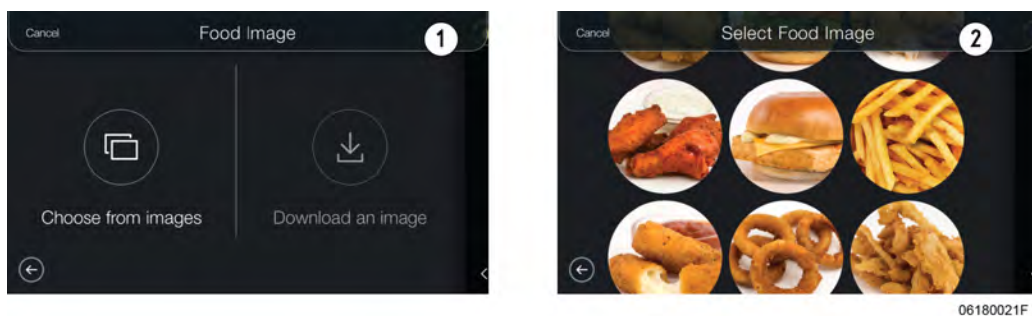

Figure 5-13

- Food Item Name** - Use the touch screen keyboard (1) to type a name for your food item. Food item names may have a maximum of 40 characters, see [Figure 5-14 , page 47](#). Tap **Done** to continue.

8. **Review Food Item** - Review your settings for the food item, see (2) in [Figure 5-14](#), [page 47](#). If you would like to change a setting, tap the setting and make the change, otherwise tap **Save** to store to the food item and finish.



Figure 5-14

5.3.3.1 Advanced Cooking Parameters

The following list describes the advanced settings for creating a food item.



Figure 5-15 Advanced cooking parameters

Table 5-3 Advanced cooking parameters

Parameter	Description
Load Compensation	Adjusts cook time based on load size. Load compensation slows the cooking time to allow larger load sizes to cook longer than standard load sizes, and speeds up the cooking time so smaller load sizes cook for a shorter amount of time than a standard load size. Setting this step to 0 turns load compensation off. The higher the number of this setting, the slower the timer counts down

	when the oil temperature drops below the LC Ref Temperature setting. To enable load compensation, tap Set , then swipe up or down to select load compensation as a number from 0–60. Tap Done to continue.
LC Ref Temperature	Reference temperature for load compensation calculations. In general this setting should be set to the average temperature of the oil while cooking a standard load size with load compensation set to 0 (off). To enable this setting, tap Set , then swipe up or down to select your desired LC Ref Temperature (round to the nearest temperature). Tap Done to continue.
Full Heat	Keeps heaters on 100% from 0–60 seconds as soon as the timer is started for this food item. Full heat helps to anticipate the oil temperature drop when product is first dropped into the oil. To enable this setting, tap Set , then swipe up or down to select the number of seconds for full heat. Tap Done to continue.
PC Factor	(pulse control factor) Helps to keep the oil temperature from overshooting the set point temperature during cooking. Heaters are on 100% when the oil temperature is at or below the setpoint temperature minus the PC Factor setting. For example if PC Factor is set to 3, and the setpoint for this food item is 350° F, heaters are on 100% when the oil temperature drops to 347°F or lower. Once the oil temperature reaches 348°F, 100% heat turns off and the heat pulses on and off to raise the oil temperature back up to 350°F. To enable this setting, tap Set , then swipe up or down to select your desired PC Factor setting from 0–60. Tap Done to continue.

5.4 Information

The Information menu provides data and the export of fryer set point to be used as a back up or used to transfer set points to another F5. The Information options are as follows:

5.4.1 About Fryer

Tap **About This Fryer** lets you view the serial number, configuration and software for your F5. Tap **More Information** to see specific software for specific control components.

5.4.2 Export

Follow the prompts to export set points for cooking items to a USB drive. Tap **Export** then unscrew the cap for the USB port at the front of the fryer. Tap **Insert** once the USB drive has been inserted into the port. The control starts exporting the file. **Export successful** is displayed when the export has completed. Remove the USB drive and tap **OK** when finished.

5.5 Advanced

See service manual.

5.6 Service

See service manual.

5.7 Help

Tap help to find training tutorials such as an **F5 Quick Start Training** and a **Drain Pan Assembly** tutorial. This is training right where you need it without having to go find the manual. More help guides are on the way in future software releases.

5.8 Shutdown Vat

From **Settings**, swipe up and **Shutdown Vat** appears. Tap Shutdown vat to turn the vat off. The control remains on, however the heat is off. **Tap to Preheat** displays on the touchscreen.

Chapter 6 Maintenance

6.1 Maintenance Schedule

The following is the F5 maintenance schedule. Tap the link to go directly to the procedure in this manual.

Table 6-1 Scheduled Maintenance

Frequency	Task	Link to Procedure
Daily	Perform a daily filter on each vat	5.2.2 Daily filter, page 37
Daily	Clean filter pan and install a new filter	4.7.2.2 Cleaning the filter pan, page 31
Daily	Remove and clean the basket hanger	4.7.2 Filter pan assembly, page 30
Daily	Clean exterior of fryer	Wipe down the exterior of the fryer including the controls.
Weekly	Clean behind fryer	6.2.1 Clean Behind Fryer, page 51
As Required	Dispose of oil	5.2.4 Dispose Oil, page 39
Quarterly	Replace filter pan o-rings	6.2.3 O-Ring replacement, page 52
Quarterly	Perform the deep clean procedure	6.2.2 Deep Clean, page 51

6.2 Maintenance Procedures

OFE-51X fryer maintenance procedures are in this section.

6.2.1 Clean Behind Fryer

Pull out the fryer. Unplug all power cords, the clean oil, grease and debris from the sides and behind the fryer.

6.2.2 Deep Clean



WARNING

Burn Risk! To avoid burns from hot splashing water, chemicals and hot surfaces, use approved safety equipment including an apron, face shield, and gloves before starting the deep clean procedure.

The deep clean procedure removes built up carbon deposits from the heating elements, sides of the vat and bottom of the vat. The Deep Clean procedure must be performed quarterly. This may need to be performed more often depending on breading, type of product cooked / volume.

- 1) Tap Settings, then tap **Deep Clean**.
- 2) Dispose of oil in the vat following the on-screen prompts.
- 3) Cover adjacent vats.
- 4) Prepare the filter pan - Remove the filter pan, then remove the inner components of the filter pan (filter screen, filter weight, crumb basket) and set these aside. put the filter pan cover on the filter pan and push under the fryer.
- 5) Fill the vat about 1" (1.5cm) above the upper fill line with water.
- 6) Select **Hot** or **Cold** soak.

INFO: Hot or cold soak depends on the type of cleaner being used for the procedure. Read the instructions on the cleaner to see which type of soak to use.

- 7) Add an amount of fryer cleaner recommended by the cleaner manufacturer.
- 8) Start the procedure. Cold soak sits overnight while a hot soak heats the water and starts a timer.
- 9) After the soak, scrub the vat with a gong brush and L-brush to remove carbon build up from the fry vat and from the heating elements.
- 10) Choose to drain the water mix into the filter pan, or to manually remove the water from the vat. Follow the on-screen prompts to remove the water.
 - Drain to filter pan- After water drains, remove the filter pan and dump into an approved drain.
 - Manual removal of water - Scoop out the water into an approved container. Dump collected water into an approved drain.
- 11) Lift elements and scrub vat.
- 12) Rinse the vat with clean cool water.
- 13) Remove the water. Choose either to drain to pan, then empty the drain pan, or manually remove and discard water.
- 14) Fill the vat again with water for the final rinse, then repeat step #10.
- 15) Tap and hold **Purge** to pump new oil through the lines and remove water from the lines.
- 16) Towel dry the vat.
- 17) Empty and towel dry the filter pan.
- 18) Re-assemble the drain pan with a new filter and insert under the fryer.
- 19) Fill the vat with oil.

6.2.3 O-Ring replacement

Replace all three filter pan o-rings every 90 days as follows:

- 1) Remove the drain pan.
- 2) Using a small flat-bladed screwdriver, pry up on o-rings (1) and pull them off of the end of the tube. see [Figure 6-1 Filter Pan O-Rings, page 53](#).
- 3) Place an o-ring (1) into each notch, three total.

- 4) Lubricate o-rings (1) on filter tube with fresh cool oil.
- 5) Install filter pan.

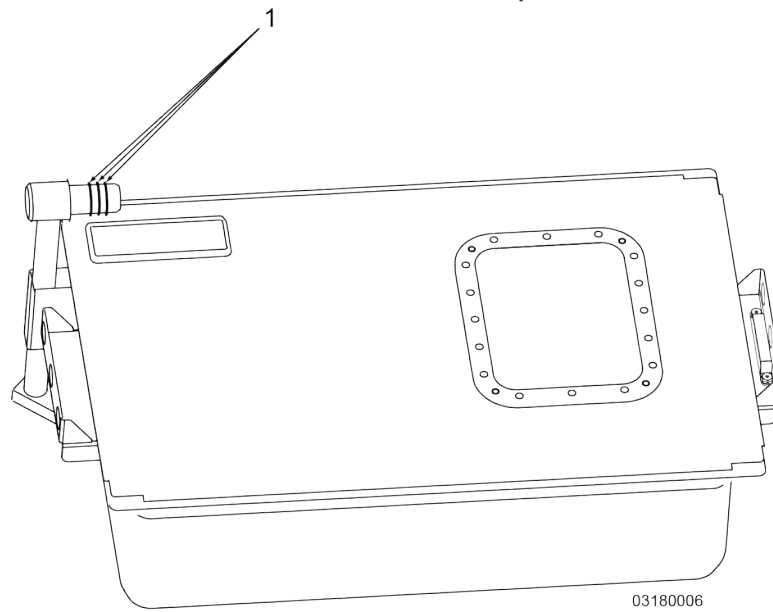

Figure 6-1 Filter Pan O-Rings

Chapter 7 Troubleshooting

7.1 Error Messages

The following is a list of error codes from the F5. Errors marked as critical errors indicate a situation that requires immediate attention. To resolve an error, perform all of the corrective action steps until the error is resolved. If after performing all of the corrective action steps the error still remains, contact technical support for assistance, see [1.5 Technical Support, page 4](#).

Table 7-1 Error Codes

Error Code	Possible Cause	Corrective Action
"E-4" "Fryer control overheat"	A source of heat is too close to the fryer.	Either move the source of heat away from the fryer, or move the fryer away from the source of heat.
	The cooling fan within the control assembly is not functioning.	Contact technical support for assistance. see 1.5 Technical Support, page 4 .
"E-5" "Oil overheat" The oil in the vat has reached tempera- tures at or above 400° F (204°C)	If the actual temperature of oil is too hot, the temperature sensor may be covered with breadding or food product.	Clean debris off of the temperature sensor inside the vat.
	Excessive carbon build up exists on the temperature sensor because a deep clean has not been performed in the last 3 months.	Perform a deep clean procedure. This helps loosen debris that may have formed around the temperature probes.
"E-6" "Cannot read tem- perature "	The temperature sensor is damaged or disconnected. <i>NOTICE:</i> Sensors can be damaged if struck with baskets or other hard objects. Use brushes only when cleaning sensors in the vat.	Contact technical support for assistance, see 1.5 Technical Support, page 4 .
"E-10" "Safety sensor overheat" The fryer high limit safety sen- sor over- heated and tripped.	If express filters are repeatedly skipped, the safety sensor becomes covered with crumbs causing it to overheat.	Allow 15 minutes for the vat to cool. Filter to remove crumbs from the bottom of the vat. Reset the high limit and ensure express filters are performed when prompted.
	If the vat has no oil, or the oil level is below the temperature sensor, the safety sensor will overheat.	Allow 15 minutes for the vat to cool. Ensure the vat is filled with oil, then reset the high limit.

Error Code	Possible Cause	Corrective Action
	If the deep clean has not been performed in the last 3 months, carbon will build up and insulate the safety sensor causing it to overheat.	Allow 15 minutes for the vat to cool. Reset the high limit then perform a deep clean on the vat.
"E-18" "Level Sensor Failure"	The level sensor is either damaged or has come disconnected. <i>NOTICE:</i> Sensors can be damaged if struck with baskets or other hard objects. Use brushes only when cleaning sensors in the vat.	Contact technical support for assistance, see 1.5 Technical Support, page 4 .
"E-21" "Oil heating failure" The vat is heating the oil too slowly. Cooking is still possible.	WARNING! Heating capacity for this vat may be reduced and product may be undercooked. Always check product temperature before serving or severe illness may result.	
	The power cord is not pushed all of the way into the receptacle.	Ensure that each power cord of the fryer is pushed in all the way.
	Low voltage, or voltage issue at the receptacle.	Contact a certified electrician to troubleshoot issues with the receptacle, breaker, or supply voltage.
"E-22" "Check power supply" Vat not heating.	The power cord for the vat is not plugged in / not pushed in all the way.	Ensure that each power cord of the fryer is plugged in and pushed in all the way.
	The breaker is tripped.	Reset the circuit breaker.
	No voltage at receptacle.	For two, three and four vat units, perform a quick check by switching plugs with another working vat. If the vat now starts to heat, then the original receptacle had no voltage. Contact a certified electrician to troubleshoot issues with the receptacle, breaker, or supply voltage. If after switching the plugs, the vat still does not heat, contact Henny Penny technical support for assistance, see 1.5 Technical Support, page 4 .
"E-31" "Heating Elements Up"	Crumb build up is not allowing the heating element to fully lower.	Perform an express filter and remove the excess crumb build up under the heater.
	The heater wasn't pushed down all of the way after the daily filter.	Use a fryer basket to gently push down on the heating element.
"E-41" "Controller data loss"	Programming failure.	Turn main power switch off and back on again, if error code persists,

Error Code	Possible Cause	Corrective Action
		contact technical support for assistance, see 1.5 Technical Support, page 4 .
"E-46" "Memory write failure"	Programming failure.	Turn main power switch off and back on again, if error code persists, contact technical support for assistance. See 1.5 Technical Support, page 4 .
"E-47" "A to D failure"	Internal control failure.	Turn main power switch off and back on again, if error code persists, contact technical support for assistance, see 1.5 Technical Support, page 4 .
"E-48" "Controller input failure"	Input system failure.	Turn main power switch off and back on again, if error code persists, contact technical support for assistance, see 1.5 Technical Support, page 4 .
"E-60" "Filtration board communication" Fryer still heats, however no filtration or top off is performed.	AIF board, power supply or communication failure.	Turn main power switch off and back on again, if error code persists, contact technical support for assistance, see 1.5 Technical Support, page 4 .
"E-70C" "Drain interlock failure" Filtration cannot be performed.	Communication with the drain valve has failed.	Contact technical support for assistance, see 1.5 Technical Support, page 4 .

Error Code	Possible Cause	Corrective Action
"E-82" "Selector valve failed" Filtration and auto top off of vats cannot be performed.	No response from the selector valve.	Turn main power switch off and back on again, if error code persists, contact technical support for assistance, see 1.5 Technical Support, page 4 .
"E-93A" "Supply tripped"	Power supply failed.	Contact technical support for assistance. see 1.5 Technical Support, page 4 .

7.2 Troubleshooting Guide

Table 7-2 Troubleshooting

Problem	Possible Cause	Corrective Action
Cooking Section - Product Color Not Correct:		
A. Product is too dark (some batches).	Crumbs or carbon build up covering temperature sensor.	Thoroughly remove all debris from the temperature sensor.
	Product not removed from vat promptly after countdown timer sounds.	Remove product from vat when countdown timer sounds.
	Wrong food item timer selected.	Select the correct food item timer.
Too dark (all batches).	Food item cooking temperature set too high.	Re-adjust food item cooking temperature to a lower setting.
	Temperature probe out of calibration, or improper voltage.	Contact Henny Penny technical Support for assistance, see 1.5 Technical Support, page 4 .
	Oil too old.	If oil is smoking or has a burnt taste, change oil.
	Oil too dark.	<ul style="list-style-type: none"> • If oil is smoking or has burnt taste, change oil. • Filter oil. • Perform clean-out procedure.
Too light (all batches).	Food item cooking temperature set too low.	Re-adjust food item cooking temperature to a higher setting.

Problem	Possible Cause	Corrective Action
	Temperature probe out of calibration.	Contact Henny Penny technical Support for assistance, see 1.5 Technical Support, page 4 .
	Slow fryer heat-up/recovery.	See E-21 "Oil Heating Failure" error.
Too light (some batches).	Product too cold. For example, product was put into the oil frozen when store policy is to have it thawed. Check with store standards.	Allow product to thaw before cooking.
	Food item timer started before product was placed in oil.	Place product in oil first, then start the corresponding food item timer.
	Wrong food item timer selected.	Select the correct food item timer.
	Cook cycle stopped before food item timer reached 0:00 and alarm sounded.	Leave product in oil for the entire cook time.
	Load size too large.	Only drop standard size loads or increase load compensation setting.
Dryness of product.	Moisture loss prior to cooking.	<ul style="list-style-type: none"> • Use fresh product. • Cover product to reduce evaporation.
	Over-cooking the product.	Product not removed from vat promptly after countdown timer sounds.
	Food item timer set too long.	Shorten the cooking timer for this food item.
	Wrong food item timer selected.	Select correct food item timer.
Burned taste.	Burned oil flavor.	Replace oil and perform a deep clean.
	Express filters not performed when prompted.	Perform express filters when prompted.
	Daily filter not performed.	Perform the daily filter once per day.
	Incorrect heating elements or improper voltage.	Contact Henny Penny technical support for assistance, see 1.5 Technical Support, page 4 .

Problem	Possible Cause	Corrective Action
Product not done.	Cook cycle stopped before food item timer reached 0:00 and alarm sounded.	Leave product in oil for the entire cook time.
	Food item cooking timer too short.	Lengthen the cooking time for this food item.
	Load size too large.	Only drop standard size loads or increase load compensation setting.
	Wrong food item timer selected.	Select the correct food item timer.
	Food item cooking temperature set too low.	Adjust food item cooking temperature to a higher setting.
	Temperature probe out of calibration.	Contact Henny Penny technical support for assistance, see 1.5 Technical Support, page 4 .
	Slow fryer heat-up/recovery.	See E-21 "Oil Heating Failure" error.
Fryer power and controls		
With power switch in on position, touchscreen displays do not power up.	Fryer is unplugged.	Plug in all power cords behind the fryer and push in all the way.
	Fryer circuit breaker is tripped.	Reset breaker.
	No voltage at receptacle.	Contact a certified electrician to troubleshoot issues with the receptacle, breaker, or supply voltage.
	Fryer electrical or control issue.	Contact Henny Penny technical support for assistance, see 1.5 Technical Support, page 4 .
Touchscreen display is on, but non-responsive.	Display is frozen.	Press and release control reset (below control).
With power switch in the on position, a single touchscreen display does not power up.	Power failure to display or control issue..	Contact Henny Penny technical support for assistance, see 1.5 Technical Support, page 4 .
Filter system		
Filter motor runs but pumps oil slowly.	O-rings worn, damaged, or missing.	Replace o-rings.

Problem	Possible Cause	Corrective Action
	Clogged filter pad / paper.	Empty the crumb basket and gently scrape crumbs off of the top of the filter. Replace filter pad or paper once per day.
	Wet filter pad / paper.	Replace filter pad or paper with a dry filter
Filter pump motor does not run.	Reset filter pump motor.	WARNING! To prevent burns caused by splashing oil, turn the main power switch to the OFF position before pressing the filter motor reset button. Allow 15 minutes for the filter motor to cool. Turn the main power switch off. Push in on the red reset button on the filter motor with a screw driver. The filter motor is located above the filter pan. Turn the main power switch back on, then in the Oil & Filter menu, test the filter motor by filling the vat from the filter pan. INFO: Use a screwdriver tip to press this button in as it is difficult to get it to reset by hand.
	Pump motor breakers tripped	WARNING! To prevent burns caused by splashing oil, turn the main power switch to the OFF position before resetting the pump motor breakers. Turn the main power switch off. Press the white reset breaker buttons located behind the far left door of the fryer. Turn the fryer power on, then in the Oil & Filter menu, test the filter motor by filling the vat from the filter pan.
Motor hums but does not run.	Clogged lines or pump clogged.	Contact Henny Penny technical support for assistance, see 1.5 Technical Support, page 4 .
	Solid shortening used in fryer.	Contact Henny Penny technical support for assistance. Do not use solid shortening in the F5 fryer, see 1.5 Technical Support, page 4 .
The filter pan is inserted under the fryer. Display reads	Filter pan not pushed in all of the way.	Push the filter pan back all the way. WARNING! Burn risk! Drain pan may be hot. Wear heat and oil

Problem	Possible Cause	Corrective Action
Cannot detect drain pan.		resistant gloves before moving the Drain pan.
	Power cords behind fryer not allowing the drain pan to go back all of the way.	Reposition power cords behind the fryer so they don't interfere with the travel of the drain pan.
	Drain pan cover not installed on the drain pan.	Remove drain pan, place the cover on the top of the drain pan, then re-install the drain pan under the fryer. WARNING! Burn risk! Drain pan may be hot. Wear heat and oil resistant gloves before moving the drain pan.
	Drain pan switch failure.	Contact technical support for assistance, see 1.5 Technical Support, page 4 .
Filter motor continues to run and pump air bubbles when the vat is full. Display reads Cannot detect oil level .	Crumbs and carbon build up covering the detect and level sensors in the vat.	Remove all crumbs and carbon build up around the sensors in the vat.
	Drain pan is empty, however there was not enough oil that pumped back into the vat to reach the level probe.	Fill the vat with oil, see Figure 5-7 Fill Vat, page 41 .
	Oil was cool when filtering.	Filter oil at set point temperature.
Oil not draining during express filter. Display reads Is the oil draining?	Drain Clogged.	Use the drain brush to push crumbs through the drain valve. As oil starts to drain, remove the drain brush. <i>NOTICE:</i> Always remove the drain brush from the drain valve when oil starts to drain, or the drain valve will close on the drain brush. Drain valve damage, not covered under warranty, may result. BEST PRACTICE! Always filter and skim the vat when prompted to avoid crumb accumulation and drain clogging.
	Drain not opening.	Contact technical support for assistance, see 1.5 Technical Support, page 4 .
Oil remains in the drain pan. Display reads Is the vat	O-rings worn, damaged, or missing.	If there is oil in the filter pan, it will need to be removed prior to performing this step.

Problem	Possible Cause	Corrective Action
filled as shown? Yes/No		WARNING! Burn risk! Allow time for oil to cool and wear Personal Protective Equipment (PPE) including heat and oil resistant gloves, apron and face shield while performing this procedure. Do not move the fryer or filter drain pan while containing hot oil. Personal injury or serious burns can result from splashing hot oil. Replace o-rings.
	Clogged filter pad / paper.	If there is oil in the filter pan, it will need to be removed prior to performing this step. WARNING! Burn risk! Allow time for oil to cool and wear PPE including heat and oil resistant gloves, apron and face shield while performing this procedure. Do not move the fryer or filter drain pan while containing hot oil. Personal injury or serious burns can result from splashing hot oil. Empty the crumb basket and gently scrape crumbs off of the top of the filter. Replace filter pad or paper once per day.
	Wet filter pad / paper.	If there is oil in the filter pan, it will need to be removed prior to performing this step. WARNING! Burn risk! Allow time for oil to cool and wear PPE including heat and oil resistant gloves, apron and face shield while performing this procedure. Do not move the fryer or filter drain pan while containing hot oil. Personal injury or serious burns can result from splashing hot oil. Replace filter pad or paper with a dry filter.
Auto top off system		
Vat not topping off, but there is oil in the JIB. Display reads Is there oil in the JIB? Yes/No.	Three attempts to auto top off the vat with no success.	1. Check for debris at the end of the JIB tube.

Problem	Possible Cause	Corrective Action
		<p>2. Make sure the JIB tube is inserted in the JIB and pushed all the way down to the bottom.</p> <p>3. Try filling the vat from Oil & Filter > Fill Vat and then perform a Fill from JIB to see if the vat starts to fill.</p> <p>INFO: It may take up to 20 seconds before oil starts to pump to purge air from the lines.</p> <p>If the vat still does not fill, contact technical support for assistance, see 1.5 Technical Support, page 4.</p>
<p>Oil continues to top off even though full. Display reads Is there oil in the JIB? Yes/No.</p>	<p>Crumbs / carbon built up around the temperature or level sensors in the vat.</p>	<p>Remove any crumbs or carbon build up from the sensors in the vat.</p>
	<p>The temperature or level sensors are damaged</p>	<p>Contact technical support for assistance, see 1.5 Technical Support, page 4.</p>

Chapter 8 Parts and Accessories

8.1 Fryer Accessories

The fryer accessories used with the F5 are listed in this section. Contact your local Henny Penny distributor to order. Accessories are shown in [Figure 8-1 Fryer Accessories, page 65](#) and described in [Table 8-1 Fryer Accessories, page 66](#). Additional supplies are listed in [Table 8-2 Fryer Supplies, page 67](#).

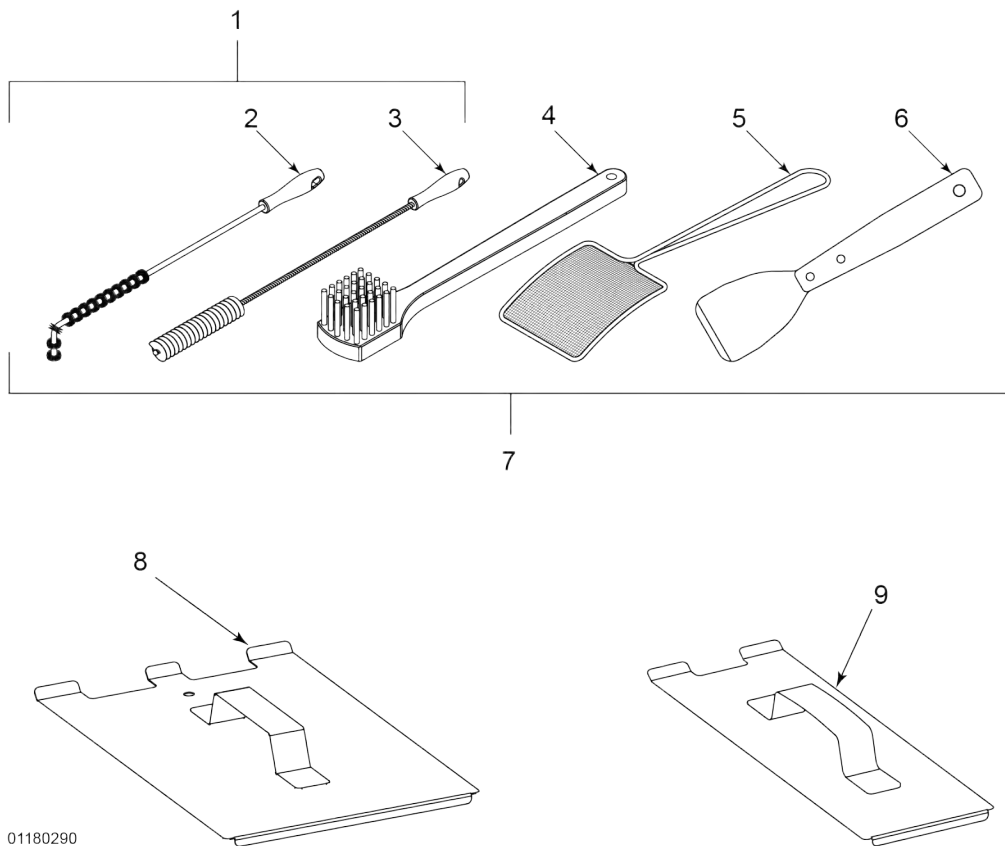

Figure 8-1 Fryer Accessories

Table 8-1 Fryer Accessories

Item	Accessory	Part No.	Description
1	BRUSH SET	12105	A brush set containing items 2 and 3 only.
2	BRUSH, BLACK L TIPPED	12126	Used to clean corners and the bottom of the vat.
3	BRUSH, WHITE, STRAIGHT	12112	This brush is used to scrub the drain and other narrow places.
4	BRUSH-FRYER GONG	12116	This is a general purpose brush. This brush is used to scrub the fryer during cleaning. It can be used scrub just about anything as far a cleaning is concerned.
5	SKIMMER	23850	The skimmer is used to clean crumbs from the vat before filtering the fryer. It can also be used throughout the day to keep the vat clean.
6	SCRAPER	12160	The scraper is used to scrape grease, dirt, or other material from the fryer.
7	BRUSH KIT	14736	The brush kit contains items 2, 3, 4, 5, and 6.
8	FULL VAT NIGHT COVER	78635	The full vat night cover is used to cover a full vat when cleaning or not using the fryer. The cover protects from cleaners, dust, and other debris from getting into the vat.
9	SPLIT VAT NIGHT COVER	74957	The split vat night cover is used to cover a split vat when cleaning or not using the fryer. The cover protects from cleaners, dust, and other debris from getting into the vat.
10*	ELEMENT LIFT TOOL	74725	Lifts the heating elements during a daily filter for easier cleaning of the vat.
11*	AUTO TOP-OFF JUG	03617	A food safe jug to store fresh oil if your oil is not delivered in a JIB. Oil stored in this jug automatically fills vats needing fresh oil.
11*	TETHER KIT	03156	A tether cable and associated hardware should local ordinances require a fryer to be attached to a permanent structure.
* = Not Shown			

Table 8-2 Fryer Supplies

Item	Accessory	Part No.	Description
1	SMART FILTER PAPER	12076	A single layer filter paper with no oil extending additives. Works well with prime filter powder.
2	PRIME FILTER POWDER	12088	Frying oil life extender to help reduce oil costs, improve food quality, and reduce labor.
3	PRIME FILTER HD PADS	12090	Filter pad with prime filter powder impregnated within it. The most convenient way to extend oil life.
4	PRIME FILTER HD PACKETS	12092	4.8 oz pre-measured packet of prime filter powder.
5	PHT DRY POWDER	12101	Tough, all-purpose cleaner for thoroughly cleaning fry vats after oil disposal (ready-to-mix formula).
6	PHT LIQUID CLEANER	12135	Tough, all-purpose cleaner for thoroughly cleaning fry vats after oil disposal.
7	FOAMING DEGREASER	12226	All-purpose cleaner / degreaser for use on stainless steel equipment and other surfaces such as floors, walls, counters, ventilation hoods, and etc.
8	PUMP SPRAYER FOR DEGREASER	12231	Bottle and pump used for applying foaming degreaser.
9	NEOPRENE GLOVES	12072	Heat-resistant, liquid proof gloves that can be used as part of Personal Protective Equipment (PPE) when handling hot oil.
10	GOGGLES	12232	Eye protection that can be used as part of PPE.



Henny Penny Corporation
P.O.Box 60
Eaton, OH 45320
www.hennypenny.com

Inside the U.S.:
1-800-417-8405
technicalservices@hennypenny.com

Outside the U.S.
1-937-456-8405
intltechsupport@hennypenny.com