



OPERATOR'S M A N U A L

OPEN FRYER

**MODEL
OFE-391**



HENNY PENNY
Engineered to Last

REGISTER WARRANTY ONLINE AT WWW.HENNYPENNY.COM

NOTICE

This manual should be retained in a convenient location for future reference.

A wiring diagram for this appliance is located on the rear shroud cover of the control panel.

Post in a prominent location, instructions to be followed if user smells gas. This information should be obtained by consulting the local gas supplier.

Do not obstruct the flow of combustion and ventilation air. Adequate clearance must be left all around appliance for sufficient air to the combustion chamber.

The Model OFG-391 open fryer is equipped with a continuous pilot. But fryer can not be operated with out electric power. Fryer will automatically return to normal operation when power is restored.

CAUTION

Keep appliance area free and clear from combustibles.



Improper installation, adjustment, alteration, service or maintenance can cause property damage, injury or death. Read the installation, operating and maintenance instructions thoroughly before installing or servicing this equipment.



DO NOT STORE OR USE GASOLINE OR OTHER FLAMMABLE VAPORS AND LIQUIDS IN THE VICINITY OF THIS OR ANY OTHER APPLIANCE. FIRE OR EXPLOSION COULD RESULT.

Technical Data for CE Marked Products

Nominal Heat Input: (Net)	Natural (I_{2H}) = 26,4 kW (90,000 Btu/h) Natural (I2E) = 26,4 kW (90,000 Btu/h) Natural (I2S) = 23,75 kW (81,000 Btu/h) Liquid Propane (I_{3P}) = 27,0 kW (92,000 Btu/h)
Nominal Heat Input: (Gross)	Natural (I_{2H}) = 29,3 kW (100,000 Btu/h) Natural (I2E) = 29,3 kW (100,000 Btu/h) Natural (I2S) = 26,4 kW (90,000 Btu/h) Liquid Propane (I_{3P}) = 29,3 kW (100,000 Btu/h)
Supply Pressure:	Natural (I_{2H}) = 20 mbar Natural (I2E) = 20 mbar Natural (I2S) = 25 mbar Liquid Propane (I_{3P}) = 37/50 mbar
Test Point Pressure:	Natural (I_{2H}) = 8,7 mbar Natural (I2E) = 8,7 mbar Natural (I2S) = 8,7 mbar Liquid Propane (I_{3P}) = 25 mbar
Injector Size:	Natural (I_{2H}) = 2,51 mm Natural (I2E) = 2.51 mm Natural (I2S) = 2.85 mm Liquid Propane (I_{3P}) = 1,04 mm

This appliance must be installed in accordance with the manufacturer's instructions and the regulations in force and only used in a suitable ventilated location. Read the instructions fully before installing or using the appliance.

Datos Tecnicos Para Products CE

Consumo Calorico Nominal: (Neto)	Gas Natural (I_{2H}) = 26,4 kW (90,000 Btu/h) Gas Natural (I2E) = 26,4 kW (90,000 Btu/h) Gas Natural (I2S) = 23,75 kW (81,000 Btu/h) Propano Licuado (I_{3P}) = 27,0 kW (92,000 Btu/h)
Consumo Calorico Nominal: (Bruto)	Gas Natural (I_{2H}) = 29,3 kW (100,000 Btu/h) Gas Natural (I2E) = 29,3 kW (100,000 Btu/h) Gas Natural (I2S) = 26,4 kW (90,000 Btu/h) Propano Licuado (I_{3P}) = 29,3 kW (100,000 Btu/h)
Presion De Alimentacion:	Gas Natural (I_{2H}) = 20 mbar Gas Natural (I2E) = 20 mbar Gas Natural (I2S) = 25 mbar Propano Licuado (I_{3P}) = 37/50 mbar
Presion En Ez Punto De Prueba:	Gas Natural (I_{2H}) = 8,7 mbar Gas Natural (I2E) = 8,7 mbar Gas Natural (I2S) = 8,7 mbar Propano Licuado (I_{3P}) = 25 mbar
Diámetro Boquilla:	Gas Natural (I_{2H}) = 2,51 mm Gas Natural (I2E) = 2.51 mm Gas Natural (I2S) = 2.85 mm Propano Licuado (I_{3P}) = 1,04 mm

Este equipo debe instalarse únicamente en un recinto adecuadamente ventilado y conforme a las indicaciones del fabricante y a las normas vigentes. Lea completamente las instrucciones antes de instalar o usar este equipo.

HENNY PENNY 8 HEAD GAS OPEN FRYER

SPECIFICATIONS

Height	61" (155 cm)
Width	24" (61 cm)
Depth	41¾" (107 cm)
Floor Space	Approximately 7 sq. ft. (.65 sq. m.)
Pot Capacity	8 head of chicken (20 lbs.) (9.1 kg) 130 lbs. shortening (46 Kg.)
Electrical	120 VAC, 1 Phase, 50/60 Hz, 10 Amp, 2 Wire + Ground 230 VAC, 1 Phase, 50/60 Hz, 5 Amp, 2 Wire + Ground
Heating	Propane or natural gas; 100,000 BTU/Hr.(105.48 MJ/hr.)
Shipping Weight	Approximately 670 lbs. (304 kg.)
Accessories Shipped	Five 1/2 size pan racks and carrier assembly

NOTICE

A data plate, located on the right side panel, gives the information of the type of fryer, serial number, warranty date, and other information pertaining to fryer. Also, the serial number is stamped on the outside of the frypot. See figure below.

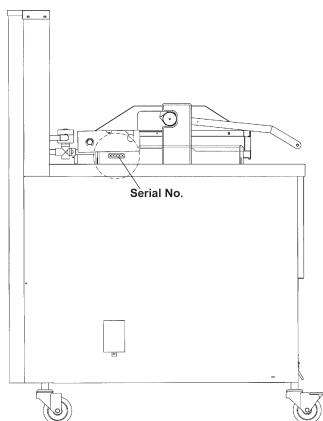

TABLE OF CONTENTS

Section	Page
Section 1. INTRODUCTION	1-1
1-1 Introduction	1-1
1-2 Proper Care	1-1
1-3 Assistance	1-1
1-4 Safety	1-2
Section 2. INSTALLATION	2-1
2-1 Introduction	2-1
2-2 Unpacking	2-1
2-3 Selecting the Fryer Location	2-4
2-4 Leveling the Fryer	2-4
2-5 Ventilation of Fryer	2-5
2-6 Gas Supply	2-5
2-7 Gas Piping	2-5
2-8 Gas Leak Test	2-8
2-9 Gas Pressure Regulator Setting	2-8
2-10 Electrical Requirements	2-9
Section 3. OPERATION	3-1
3-1 Operating Components	3-1
3-2 Lid Operation	3-3
3-3 Switches and Indicators	3-3
3-4 Clock Set	3-6
3-5 Filling or Adding Shortening	3-8
3-6 Product Racking Recommendations	3-9
3-7 Basic Operation	3-10
3-8 Care of Shortening	3-13
3-9 Filtering Instructions	3-13
3-10 Changing the Filter Envelope	3-16
3-11 Lighting and Shutdown of Burners	3-18
3-12 Filter Pump Motor Protector-Manual Reset	3-19
3-13 Cleaning the Frypot	3-19
3-14 Regular Maintenance Schedule	3-21
3-15 Preventive Maintenance	3-22
3-16 Programming	3-25
3-17 Special Program Mode	3-31
3-18 Data Logging, Heat Control, Tech Mode and Stat Mode	3-39
3-19 Information Mode	3-40
Section 4. TROUBLESHOOTING	4-1
4-1 Troubleshooting Guide	4-1
4-2 Error Codes	4-2
GLOSSARY	G-1
Distributors List - Domestic and International	

SECTION 1. INTRODUCTION

1-1. INTRODUCTION

The Henny Penny open fryer is a basic unit of food processing equipment. This unit is used only in institutional and commercial food service operations.

NOTICE



As of August 16, 2005, the Waste Electrical and Electronic Equipment directive went into effect for the European Union. Our products have been evaluated to the WEEE directive. We have also reviewed our products to determine if they comply with the Restriction of Hazardous Substances directive (RoHS) and have redesigned our products as needed in order to comply. To continue compliance with these directives, this unit must not be disposed as unsorted municipal waste. For proper disposal, please contact your nearest Henny Penny distributor.

1-2. PROPER CARE

As in any unit of food service equipment, the Henny Penny open fryer does require care and maintenance. Requirements for the maintenance and cleaning are contained in this manual and must become a regular part of the operation of the unit at all times.

1-3. ASSISTANCE

Should you require outside assistance, call your local independent distributor in your area, or call Henny Penny Corp. at 1-800-417-8405 or 1-937-456-8405.

1-4. SAFETY

The Henny Penny open fryer has many safety features incorporated. However, the only way to ensure a safe operation is to fully understand the proper installation, operation, and maintenance procedures. The instructions in this manual have been prepared to aid you in learning the proper procedures. Where information is of particular importance or safety related, the words DANGER, WARNING, CAUTION, and NOTICE are used. Their usage is described below.



SAFETY ALERT SYMBOL is used with **DANGER**, **WARNING**, or **CAUTION** which indicates a personal injury type hazard.



NOTICE is used to highlight especially important information.



CAUTION used without the safety alert symbol indicates a potentially hazardous situation which, if not avoided, may result in property damage.



CAUTION used with the safety alert symbol indicates a potentially hazardous situation which, if not avoided, may result in minor or moderate injury.



WARNING indicates a potentially hazardous situation which, if not avoided, could result in death or serious injury.



DANGER INDICATES AN IMMINENTLY HAZARDOUS SITUATION WHICH, IF NOT AVOIDED, WILL RESULT IN DEATH OR SERIOUS INJURY.

SECTION 2. INSTALLATION

2-1. INTRODUCTION

This section provides the installation and unpacking instructions for the Henny Penny model OFG-391, open fryer.

NOTICE

Installation of this unit should be performed only by a qualified service technician.



Do not puncture the fryer with any objects such as drills or screws as component damage or electrical shock could result.

2-2. UNPACKING INSTRUCTIONS

NOTICE

Any shipping damage should be noted in the presence of the delivery agent and signed prior to his or her departure.

1. Cut and remove the metal bands from the carton.
2. Remove the carton lid and lift the main carton off the fryer.
3. Remove corner packing supports (4).
4. Cut the stretch film from around the carrier/rack box and remove it from the top of the fryer lid.
5. Cut and remove the metal bands holding the fryer to the pallet.



All counterweights must be loaded before unlatching the lid, or personal injury could result.

6. Remove the fryer from the pallet.



Take care when moving the fryer to prevent personal injury. The fryer weighs approximately 670 lbs. (304 kg).

2-2. UNPACKING
INSTRUCTIONS
(Continued)

7. Remove the counterweights from the pallet, which are strapped to the pallet, under the fryer.



Do not drop. The counterweights weigh approximately 18 lbs. (8.1 kg.) each. Handle with care, or personal injury could result.

8. Remove rear service cover.
9. Load the 4 weights into the counterweight assembly.
10. Replace rear service cover.



To avoid personal injury and assure safe operation of unit, rear service cover must be in place.

11. Cut warning tags from the lid assembly. The lid may now be unlatched.
12. Remove the accessories from inside the filter drain pan.



The fittings for installing the gas line are in a separate box, along with the accessories, in the filter drain pan.

13. Remove the protective paper from the fryer cabinet. Clean exterior surface with a damp cloth.

Optional Ramp Unloading

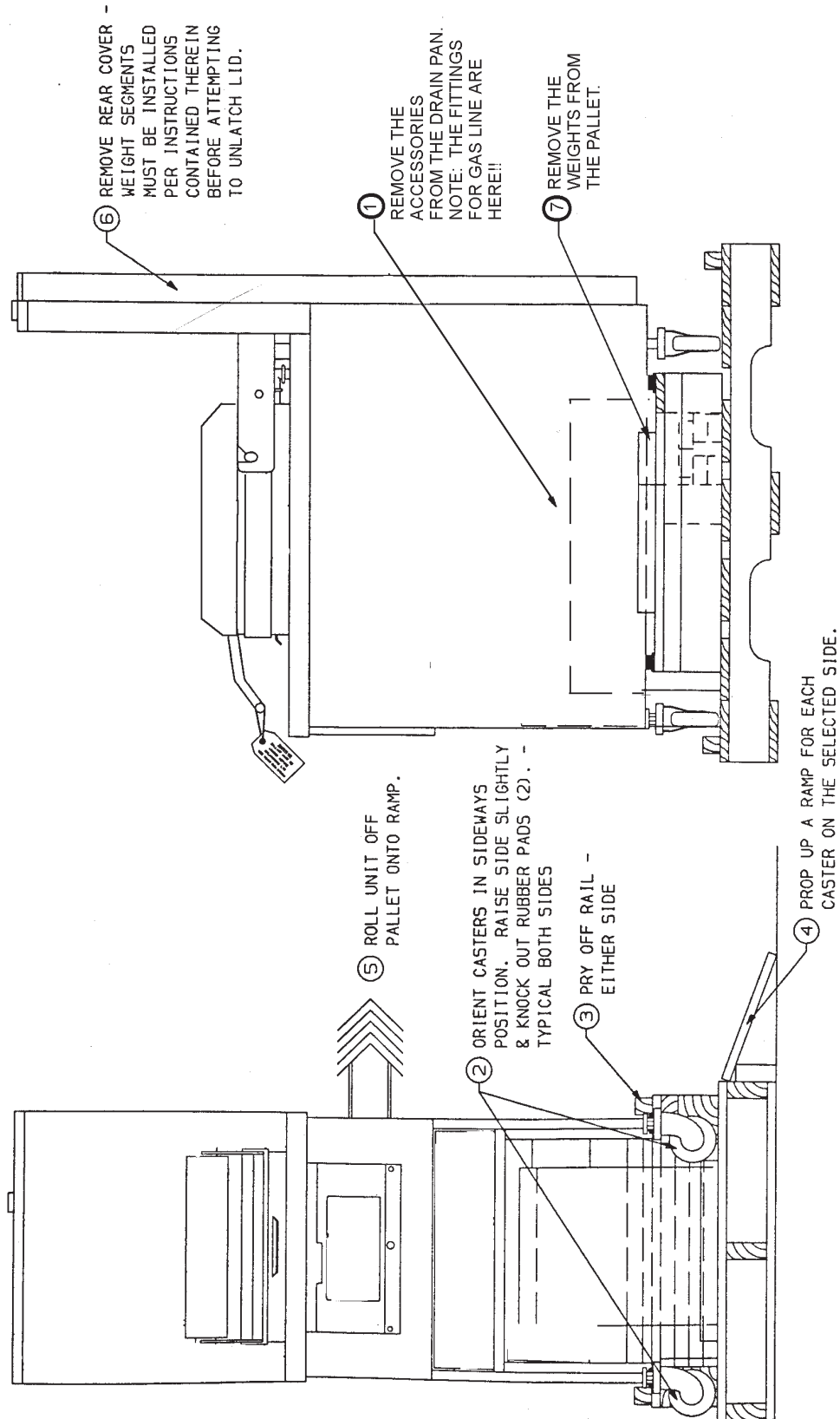

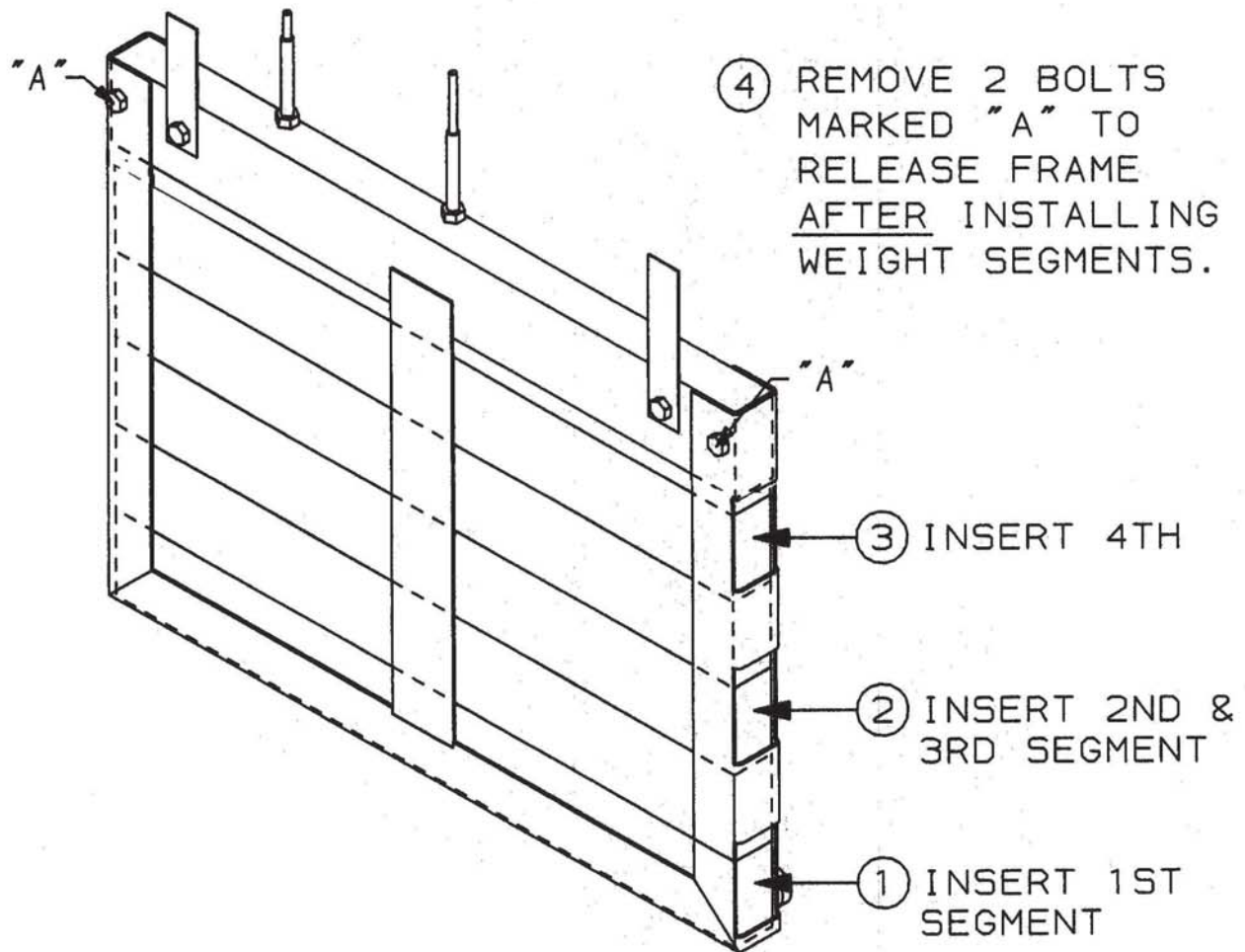

 **CAUTION**

- * EACH WEIGHT SEGMENT WEIGHS APPROXIMATELY 18 LBS. (8.1 KG) – HANDLE WITH CARE.
- * ALL SEGMENTS ARE IDENTICAL.
- * ALL SEGMENTS MUST BE INSTALLED AND SECURED IN THE FRAME BEFORE ATTEMPTING TO UNLATCH LID.

2-3. SELECTING THE FRYER LOCATION

The proper location of the fryer is very important for operation, speed, and convenience. Choose a location which provides easy loading and unloading without interfering with the final assembly of food orders. Operators have found that frying from raw to finish, and holding the product in warmer provides fast continuous service. Landing or dumping tables should be provided next to at least one side of the fryer. Keep in mind the best efficiency will be obtained by a straight line operation, i.e. raw in one side and finish out the other side. Order assembly can be moved away with only a slight loss of efficiency. To properly service the fryer, 24 inches (61.0 cm) of clearance is needed on all sides of the fryer. Access for servicing can be attained by removing a side panel. Also, at least 6 inches (15.24 cm) around the base of the unit is needed for proper air supply to the combustion chamber.



To avoid a fire, install the fryer with minimum clearance from all combustible and noncombustible materials, 6 inches (15.24 cm) from side and 6 inches (15.24 cm) from back. If installed properly, the gas Fryer is designed for operation on combustible floors and adjacent to combustible walls.

To avoid fire and ruined supplies, the area under the fryer should not be used to store supplies.



To prevent severe burns from splashing hot shortening, position and install fryer to prevent tipping or movement. Restraining ties may be used for stabilization.

2-4. LEVELING THE FRYER

For proper operation, the fryer must be level from side to side and front to back. Using a level placed on the flat areas around the frypot collar, adjust the leveling bolt or casters until the unit is level.



FAILURE TO FOLLOW THESE LEVELING INSTRUCTIONS CAN RESULT IN SHORTENING OVERFLOWING THE FRYPOT WHICH COULD CAUSE SERIOUS BURNS, PERSONAL INJURY, FIRE AND/OR PROPERTY DAMAGE.

2-5. VENTILATION OF FRYER

The fryer must be located with provision for venting into adequate exhaust hood or ventilation system. This is essential to permit efficient removal of the flue gases and frying odors. Special precaution must be taken in designing an exhaust canopy to avoid interference with the operation of the fryer. We recommend you consult a local ventilation or heating company to help in designing an adequate system.

NOTICE

Ventilation must conform to local, state, and national codes. Consult your local fire department or building authorities.

2-6. GAS SUPPLY

The gas fryer is factory available for either natural or propane gas. Check the data plate on the right side panel of the cabinet to determine the proper gas supply requirements. The minimum supply for natural gas is 7 inches water column (1.74 kPa), and 10 inches water column (2.49 kPa) for propane.

WARNING
EXPLOSION RISK

Do not attempt to use any gas other than that specified on the data plate. Incorrect gas supply could cause a fire or explosion resulting in severe injuries and/or property damage.

Please refer below for the recommended hookup of the fryer to main gas line supply.

WARNING

To avoid possible serious personal injury:

- **Installation must conform with local, state, and national codes, and be in accordance with Canadian Gas Authority Standard CSA B149- & 2, Installation Codes - Gas Burning Appliances and in accordance with Australian Gas Association current edition of AS5601 Gas Installations.**
- **The fryer and its manual shutoff valve must be disconnected from the gas supply piping system during any pressure testing of that system at test pressures in excess of 1/2 psig (3.45kPa)(34.47mbar)**



2-7. GAS PIPING
(Continued)

- **The fryer must be isolated from the gas supply piping system by closing its individual manual shutoff valve during any pressure testing of the gas supply piping system at test pressures equal to or less than 1/2 PSIG (3.45 KPA) (34.5 mbar).**
- **A standard 3/4 inch, black steel pipe and malleable fittings should be used for gas service connections.**
- **Do not use cast iron fittings.**
- **Although 3/4 inch size pipe is recommended, piping should be of adequate size and installed to provide a supply of gas sufficient to meet the maximum demand without undue loss of pressure between the meter and the fryer. The pressure loss in the piping system should not exceed 0.3 inch water column.**

Provisions should be made for moving the fryer for cleaning and servicing. This may be accomplished by:

1. Installing a manual gas shut off valve and disconnect union, or
2. Installing a heavy duty (min. 3/4 inch) design A.G.A. certified connector which complies with standard connectors for moveable gas appliances. ANSI Z21.69 or CAN/CSA 6.16. Also, a quick disconnect coupling which complies with the Standard for Quick Disconnect Devices for use with Gas Fuel, ANSI Z21.41 or CAN 1-6.9. Also, adequate means must be provided to limit the movement of the fryer without depending on the connector and any quick-disconnect device or it's associated piping to limit the fryer movement.
3. See the illustration on the following page for the proper connections of the flexible gas line and cable restraint.

NOTICE

The cable restraint limits the distance the fryer can be pulled from the wall. For cleaning and servicing the fryer, the cable must be unsnapped from the unit and the flexible gas line disconnected. This will allow better access to all sides of the fryer. The gas line and cable restraint must be reconnected once the cleaning or servicing is complete.

GAS PIPING

RIGHT

MINIMUM PULL of equipment away from wall permissible for accessibility to Quick Disconnect Device.

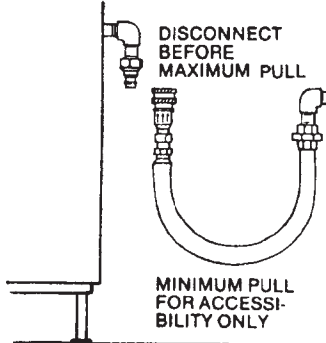

WRONG

AVOID SHARP BENDS AND KINKS when pulling equipment away from wall. (Maximum pull will kink ends, even if installed properly, and reduce Connector life.)

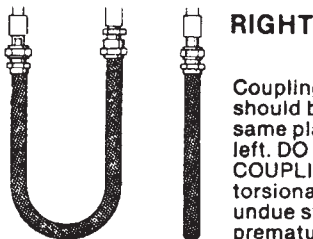
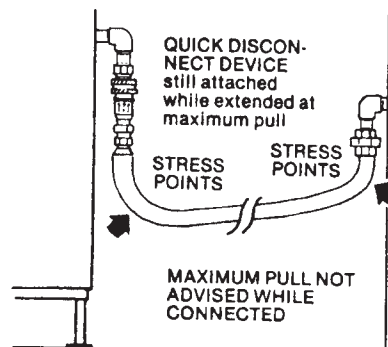

RIGHT
Couplings and hose should be installed in the same plane as shown at left. DO NOT OFFSET COUPLINGS—this causes torsional twisting and undue strain causing premature failure.

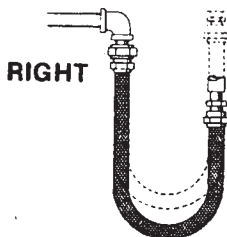
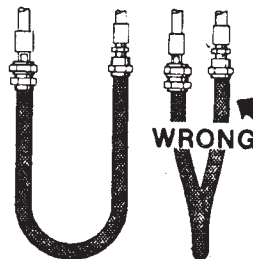

This is the correct way to install metal hose for vertical traverse. Note the single, natural loop.

Allowing a sharp bend, as shown at right, strains and twists the metal hose to a point of early failure at the coupling.

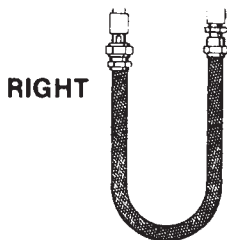
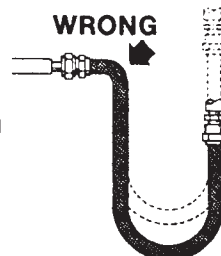

Maintain the minimum or larger bending diameter between the couplings for longest life.

Closing in the diameter at the couplings, as shown at right, creates double bends causing work fatigue failure of the fittings.

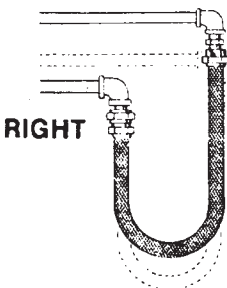
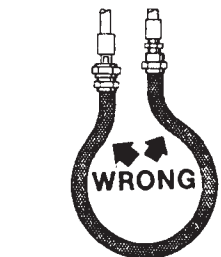

In all installations where "self-draining" is not necessary, connect metal hose in a vertical loop.

DO NOT CONNECT METAL HOSE HORIZONTALLY... unless "self-draining" is necessary, then use support on lower plane as shown at left.

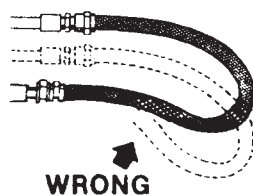

CABLE RESTRAINT

Please refer to the illustration below when installing cable restraint on all moveable gas fryers.

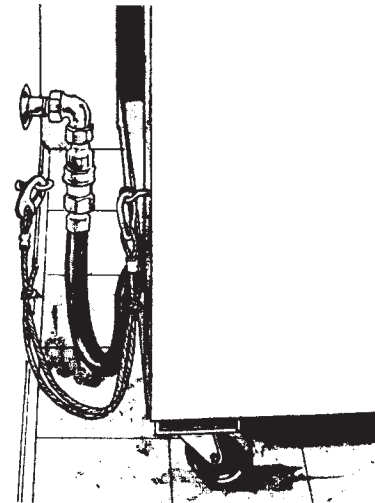

I-bolt is to be secured to the building using acceptable building construction practices.

CAUTION

DRY WALL CONSTRUCTION

Secure I-bolt to a building stud. Do not attach to dry wall only. Also, locate the I-bolt at the same height as the gas service. Preferred installation is approximately six inches to either side of service. Cable restraint must be at least six inches shorter than flexible gas line.

CAUTION

Utilize elbows when necessary to avoid sharp kinks or excessive bending. For ease of movement, install with a "lazy" loop. Gas appliance must be disconnected prior to maximum movement. (Minimum movement is permissible for hose disconnection).

2-8. GAS LEAK TEST

NOTICE

Prior to turning the gas supply on, be sure the gas valve knob on the gas control valve is in the OFF position.

The word “OFF” is at the bottom of the knob when the valve is closed.

After the piping and fittings have been installed, check for gas leaks. A simple checking method is to turn on the gas and brush all connections with a soap solution. If bubbles and occur, it indicates escaping gas. In this event, the piping connection must be redone.



To avoid fire or explosion, never use a lighted match or open flame to test for gas leaks. Ignited gas could result in severe personal injury and/or property damage.

2-9. GAS PRESSURE REGULATOR SETTING

The gas pressure regulator on the gas control valve is factory set as follows:

Natural: 3.5 inches water column (.87 kPa)

Propane: 10.0 inches water column (2.49 kPa)

NOTICE

The gas pressure regulator has been set by Henny Penny and is not to be adjusted by the user.



MAKE SURE GAS PRESSURE IS SET CORRECTLY. FAILURE TO DO SO CAN RESULT IN SHORTENING OVERFLOWING THE FRYPOT, WHICH COULD CAUSE SERIOUS BURNS, PERSONAL INJURY, FIRE AND/OR PROPERTY DAMAGE.

2-10. ELECTRICAL REQUIREMENTS

The gas fryer requires 120 volt, single phase 60 Hertz, 10 amp, 3 wire grounded (earthed) service, or 230 volt, single phase, 50 Hertz service. The 120 volt gas fryer is factory equipped with a grounded (earthed) cord and plug for your protection against shock, and should be plugged into a 3 prong grounded (earthed) receptacle. Do not cut or remove grounding (earthing) prong. A wiring diagram is located behind the right side panel, and can be accessed by removing the side panel. The 230 volt plug must conform to all local, state, and national codes.



To avoid electrical shock, do not disconnect the ground (earth) plug. This fryer must be adequately and safely grounded (earthed). Refer to local electrical codes for correct grounding (earthing) procedures or in absence of local codes, with The National Electrical Code, ANSI/NFPA No. 70-(the current edition). In Canada, all electrical connections are to be made in accordance with CSA C22.1, Canadian Electrical Code Part 1, and/or local codes.

To avoid electrical shock, this appliance must be equipped with an external circuit breaker which will disconnect all ungrounded (unearthed) conductors. The main power switch on this appliance does not disconnect all line conductors.

BOIL-OVER PREVENTION IN HENNY PENNY FRYERS



FAILURE TO FOLLOW THESE INSTRUCTIONS CAN RESULT IN SHORTENING OVERFLOWING THE FRYPOT WHICH COULD CAUSE SERIOUS BURNS, PERSONAL INJURY. FIRE AND/OR PROPERTY DAMAGE.

- **THE SHORTENING MAY BE STIRRED ONLY DURING THE MORNING START UP PROCEDURE. DO NOT STIR THE SHORTENING AT ANY OTHER TIME.**
- **FILTER THE SHORTENING AT LEAST TWICE A DAY.**
- **FILTER ONLY WHEN SHORTENING IS BELOW 275°F (135°C)..**
- **BRUSH ALL CRACKLINGS FROM FRYPOT SURFACES AND THE COLD ZONE DURING THE FILTERING PROCESS.**
- **MAKE SURE THE FRYER IS LEVEL.**
- **BE CERTAIN THE SHORTENING IS NEVER ABOVE THE UPPER FRYPOT “FILL” LINE.**
- **BE CERTAIN THAT THE GAS CONTROL VALVE AND BURNERS ARE PROPERLY ADJUSTED. (GAS UNITS ONLY)**
- **USE RECOMMENDED LOAD SIZE**

FOR ADDITIONAL INFORMATION ON THESE INSTRUCTIONS, REFER TO THE HENNY PENNY OPERATOR MANUAL AND THE KFC STANDARDS LIBRARY.

**FOR ASSISTANCE CALL THE HENNY PENNY SERVICE DEPARTMENT AT
1-800-417-8405.
or
1-937-456-8405**

SECTION 3. OPERATION

3-1. OPERATING COMPONENTS

COOK/PUMP Switch	A three way switch with center OFF position; move the switch to the position marked COOK to operate the fryer; move the switch to the position marked PUMP to operate the filter pump; certain conditions must be met prior to operation of the filter pump; these conditions are covered later in this section
Frypot	This reservoir holds the cooking shortening, and is designed to accommodate the burner tubes, 8 head of product and an adequate cold zone for collection of cracklings
Carrier	This stainless steel carrier consists of five racks which contain the food product during and after frying
Drain Valve	A two-way ball valve, normally in the closed position; turn the handle to drain the shortening from the frypot into the filter drain pan
Drain Interlock Switch	A microswitch that provides protection for the frypot in the event an operator inadvertently drains the shortening from the frypot while the main switch is in the COOK position; the switch is designed to automatically shut off the heat when the drain valve is opened
Shortening Mixing System	A shortening mixing capability to help ensure shortening is properly mixed to prevent an accumulation of moisture and hence boiling action in the pot; the filter pump is activated by the controls, at preset intervals, to mix the shortening
Lid Latch	A mechanical catch on the front of the lid which engages a bracket on the front of the frypot; this device holds the lid down while the lid is being locked into place, but is not to hold pressure in the frypot
Ignition Modules	The two ignition modules send 24 volts to the gas control valve and high voltage to the ignitors
Spark Ignitors	When the pilots are being lit, the spark ignitors are electrically energized and the tip of the ignitors spark to ignite the pilot lights

3-1. OPERATING COMPONENTS
(Continued)

High Limit

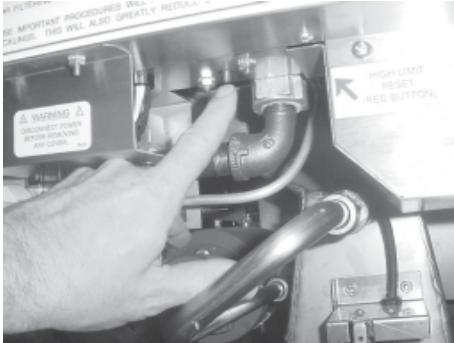

Figure 3-1

This high temperature control senses the temperature of the shortening; if the temperature of the shortening exceeds 450°F (230°C), this control will open and shut off the heat to the frypot; when the temperature of the shortening drops to a safe operation limit, the control must be manually reset by pressing the red reset button, located under the control panel, in the front of the fryer

Flame Sensors

Sense the pilot lights when the power switch is turned on; if the pilots go out, or do not light, the flame sensors shut the gas off, via the modules

Gas Control Valve

A dual controller, in which, one side of the valve controls the pilot light and the other side controls the main burner.

Airflow Switch

Senses the flow of air coming from the blower; if the airflow is reduced below a set amount, the switch cuts power to the gas control valve, which shuts down the burners

Blower

Adds the proper amount of air into the burner tubes, so an efficient combustion takes place, and also, pulls the flue gases out to the flue

Air Valve

Pumps air into the shortening, periodically, to keep the shortening at a uniform temperature; this only functions when the unit has been sitting idle for a period of time, and when heating up from a cold start

Filter Drain Pan

The removable pan that houses the filter and catches the shortening when it is drained from the frypot; also used to remove and discard old shortening



When hot shortening is in this pan, use extreme care to avoid burns.

Filter Union

Connects the filter to the filter pump, and allows easy removal of the filter and drain pan

3-2. LID OPERATION

To close lid:









1. Lower the lid until latch comes into contact with the pot.

To open lid:





1. Unlatch the front lid latch.
2. Lift up on handle to raise lid.

3-3. SWITCHES AND INDICATORS

Refer to image at end of this section.

Fig. No.	Item No.	Description	Function
3-2	1	 HEAT ON	Lights when the control calls for heat; the elements come on and heat the shortening
3-2	2	Digital Display	Shows all the functions of the Cook Cycle, Program Modes, Diagnostic Modes, and alarms
3-2	3	 PRESSURE ON	Only used on models that create pressure in the frypot; this should not light
3-2	4		Flashes when the shortening temperature is <u>not</u> at the proper temperature for cooking product
3-2	5		Lights when the shortening temperature is 5° F below to 15° F above the cooking temperature, signaling the operator that the shortening temperature <u>is</u> at the proper temperature for cooking product
3-2	6		Press to display the following fryer information and status: <ol style="list-style-type: none"> a. The temperature of the shortening b. The temperature setpoint c. Filter status d. The number of times filtered today e. The average no. of filters per day f. No. of times Cook Cycle was stopped early today g. No. of times Cook Cycle was stopped early in past week e. Oil Life Display (Only if “Change Oil” feature is enabled) f. Date and time <p>If pressed in the Program Mode, shows previous settings;</p> <p>Pressing this along with  accesses the Information Mode which has historic information on the operator and fryer’s performance</p>
3-2	7 & 8	 DOWN  UP	Used to adjust the value of the currently displayed settings in the Program Modes

3-3. SWITCHES AND INDICATORS (Continued)

Fig. No.	Item No.	Description	Function
3-2	9		<p>Press to access program modes; once in the Program Mode, it is used to advance to the next setting; if pressed along with  it accesses the Information Mode which has historic information on the operator and fryer's performance</p>
3-2	10		<p>Used to start and stop Cook Cycles, and to stop the timer at the end of a Holding Cycle</p>
3-2	11	Menu Card Window	<p>The name of the food product associated with each product selection button; the menu card strip is located behind the decal</p>
3-2	12	Product Select Buttons	<p>Are used to select the product for cooking; to use them to start cooking cycles, see section 3, Special Program Mode item SP-10</p>
3-2	13	COOK/PUMP Switch	<p>A 3-way switch with a center OFF position turn the switch to the COOK position to operate the fryer; turn the switch to the PUMP position to operate the filter pump; certain conditions must be met before operating the filter pump; these conditions are covered later in the Filtering Section of this Manual</p>
3-2	14		<p>Used to manually enter an Idle Mode, or Clean-Out Mode</p>

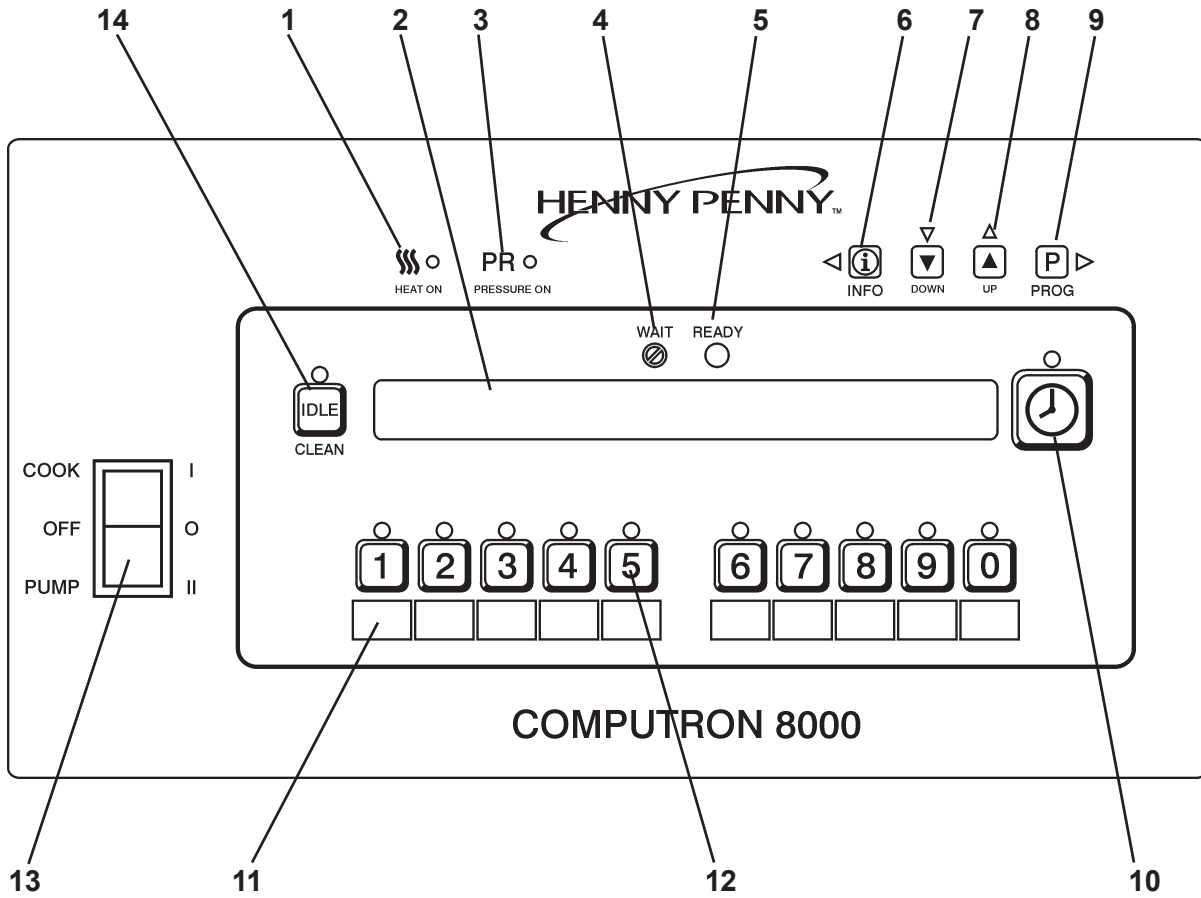





















Figure 3-2

3-4. CLOCK SET



NOTICE

Upon initial start-up, or PC board replacement, if “CLOCK SET” automatically appears in the display, start with step 4.

1. Press and hold  for 5 seconds until “LEVEL 2” shows in display.
2. Press  and “CLOCK SET”, “ENTER CODE” shows in display.
3. Press   .
4. “CS-1, SET, MONTH”, and the month flashes in the display.
5. Press the   to change the month.
6. Press  and “CS-2, SET, DATE” shows in the display, with the date flashing.
7. Press   to change the date.
8. Press  and “CS-3, SET, YEAR” shows in the display, along with the year flashing.
9. Press   to change the year.
10. Press  and “CS-4, SET, HOUR” shows in the display, with the hour and “AM” or “PM” flashing.
11. Press   to change the hour and AM/PM setting.
12. Press  and “CS-5, SET, MINUTE” shows in the display, with the minutes flashing.
13. Press   to change the minutes.

3-4. CLOCK SET
(Continued)

14. Press  and “CS-6, CLOCK MODE” shows in the display, along with “1.AM/PM”.

“1.AM/PM” is 12 hour time, “2.24-HR” is 24 hour time. Press   to change.

15. Press  and “CS-7, DAYLIGHT SAVINGS ADJ” shows in the display, along with “2.US”.

Press   to change to the following:

- a. “1.OFF” = No automatic adjustments for daylight savings time.
 - b. “2.US” = Automatically applies United States daylight savings time adjustment. DST activated on the first Sunday in April. DST de-activated on the last Sunday in October.
 - c. “3.EURO” = Automatically applies European (CE) daylight saving time adjustment. DST activated on the last Sunday in March. DST de-activated on the last Sunday in October.
16. Press  and “CS-8, BEGIN NEW DAY” shows in display, along with “3:00AM”.

This setting indicates the time of day that statistics start accumulating for a new day. If set to 3:00AM, for example, then late night cook cycles and filter operations from midnight to 3:00AM Tuesday morning, are accumulated with Monday’s statistics.

The CS-8 value can be set from 12:00AM (midnight) to 8:00AM, in half hour increments (12:00 AM, 12:30 AM, 1:00 AM, 1:30 AM, etc.). The default value for general market software is 3:00 AM.

Press   to change the time the “new” day starts.

17. Clock Set is now complete. Press and hold  to exit.

3-5. FILLING OR ADDING SHORTENING

CAUTION

The shortening level must always be above the heating elements when the fryer is heating and at the frypot level indicators on the rear of the frypot (Figure 3-3). Failure to follow these instructions could result in a fire and/or damage to the fryer.

When using solid shortening, it is recommended to melt the shortening on an outside heating source before placing it in the frypots. The burner tubes must be completely submerged in shortening. Fire or damage to the frypot could result.

1. It is recommended that a high quality frying shortening be used in the open fryer. Some low grade shortenings have a high moisture content and will cause foaming and boiling over.



To avoid severe burns when pouring hot shortening into frypot, wear gloves and take care to avoid splashing.



Figure 3-3

2. The gas model requires 130 lbs. (59 Kg.) The frypot has 4 level indicator lines inscribed on the rear wall of the frypot which show when the heated shortening is at the proper level. Figure 3-3.
3. Cold shortening should be filled to the lower indicators.



BE CERTAIN THE SHORTENING IS NEVER ABOVE THE UPPER LEVEL INDICATOR LINES. FAILURE TO FOLLOW THESE INSTRUCTIONS CAN RESULT IN SHORTENING OVERFLOWING THE FRYPOT CAUSING SERIOUS BURNS, PERSONAL INJURY, FIRE AND/OR PROPERTY DAMAGE.

3-6. PRODUCT RACKING RECOMMENDATIONS

The rack positions are referenced starting at the bottom:

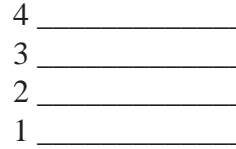

The bottom position is to be avoided on small loads because it is closer to the cold zone. (The oil is cooler at the bottom of the frypot and hotter at the top.) With bigger loads, however, there is generally enough turbulence in the oil that the bottom rack gets sufficient heat.

The top position is to be avoided on small loads because of insufficient oil coverage. With bigger loads, the top rack has good oil coverage because the volume of product on the lower racks raises the overall oil level.

Cooking ONE rack
(2-head load)

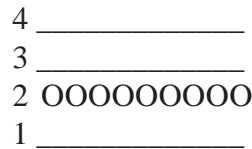

Cooking TWO racks
(4-head load)

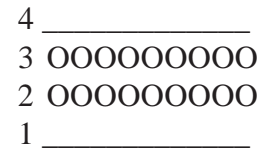

Cooking THREE racks
(6-head load)

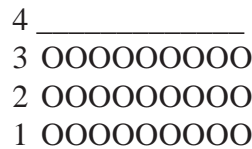

Cooking FOUR racks
(8-head load)

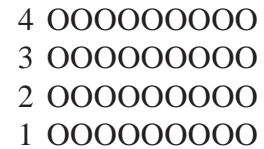

3-7. BASIC OPERATION

Follow the procedures below on the initial start-up of the fryer, and each time the fryer is brought from a cold, or shut down condition.

1. Make sure the frypot is filled with shortening to the 2 lower level indicators



DO NOT OVERLOAD, OR PLACE PRODUCT WITH EXTREME MOISTURE CONTENT INTO THE RACKS. 20 LBS. (9.0 KG.) IS THE MAXIMUM AMOUNT OF PRODUCT PER FRYPOT. FAILURE TO FOLLOW THESE INSTRUCTIONS CAN RESULT IN SHORTENING OVERFLOWING THE FRYPOT WHICH COULD CAUSE SERIOUS BURNS, PERSONAL INJURY, FIRE AND/OR PROPERTY DAMAGE.

2. Turn the COOK/PUMP switch to the COOK position and press the appropriate product button to select the amount of product to be cooked. Unit automatically goes into the Melt Cycle. When temperature reaches 250° F (121° C) the controls goes into the Heat Cycle, and heats the shortening to the setpoint temperature.



All safety devices shut off the gas supply to the burner. Follow the above procedures to restart the fryer. Notify a qualified service technician if the shut down is repeated.

3. Stir the shortening as it's heating up from a "cold" start. Be sure to stir down into the "cold zone".



DO NOT STIR THE SHORTENING AT ANY OTHER TIME EXCEPT AT MORNING START-UP. FAILURE TO FOLLOW THESE INSTRUCTIONS CAN RESULT IN SHORTENING OVERFLOWING THE FRYPOT WHICH COULD CAUSE SERIOUS BURNS, PERSONAL INJURY, FIRE, AND/OR PROPERTY DAMAGE

3-7. BASIC OPERATION
(Continued)

4. Allow fryer to heat until  illuminates.

NOTICE

Bypass the Melt Cycle, if desired, by pressing a product button and holding it for five seconds. The display shows “EXIT MELT? 1=YES 2=NO”. Press  to exit melt.



In the event of a power failure, no attempt should be made to operate the fryer. The fryer is equipped with an automatic ignition system and cannot be operated without electrical power.

CAUTION

Do not bypass the Melt Cycle unless enough shortening has melted to completely cover all of the burner tubes. If the Melt Cycle is bypassed before all burner tubes are covered, excessive smoking of shortening, or a fire could result.



NOTICE

The heat cycles on and off about 10 degrees before the setpoint temperature, to help prevent overshooting the setpoint temperature. (proportional control)

Once out of the Melt Cycle,  flashes until 5° before setpoint temperature is reached. Then  illuminates and the selected product shows in the display.

5. Before loading product onto the racks, lower the racks into the hot shortening to prevent the product sticking to the racks.
6. Slide racks of breaded product into carrier on the lid, starting with the bottom rack, to prevent damaged product.
7. Lower and latch the lid, and press .

NOTICE

A different product can be selected during the first minute of cooking, in case the wrong product button was pressed. To check the shortening temperature press  or to stop a Cook Cycle, press .

8. At the end of the cycle, an alarm sounds, while the display shows “DONE”. Then press .

WARNING

To avoid property damage do not leave fryer unattended.

3-7. BASIC OPERATION
(Continued)

9. Unlatch and raise the lid cautiously.
10. Using the rack handles, remove the racks of product from the carrier, starting with the top rack, to prevent damaged product.
11. If a Quality time (hold time) was programmed, the controller automatically starts the hold timer. The display alternately shows the product selected and the quality time remaining in minutes. If a different product is selected during the Hold Cycle, the display only shows the product selected.
12. At the end of the Hold Mode, a tone sounds, the display flashes “QUALITY”, and the product it was timing. Press and release  .

NOTICE

In the Cook Mode, when “FILTER SUGGESTED”, shows in the display, the operator has the option to filter at this time, or to continue cooking. But, if the operator continues cooking, a Filter Lockout occurs within the next Cook Cycle, or two.

When “FILTER LOCKOUT” , then “YOU *MUST* FILTER NOW.....” shows in the display,  is the only button that

functions, until the unit is filtered. Follow the filtering instructions in this manual.

Once filtering is complete and the COOK/PUMP switch is turned back on, “IS POT FILLED” shows in the display, followed by “1=YES 2=NO”.

If shortening is at the proper level in the frypot, press  and the controls start a normal heating process.

If shortening is NOT at the proper level, press  and “TURN OFF UNTIL FILLED...” scrolls through the display. Turn the COOK/PUMP switch to the OFF position, fill frypot to the proper level, then turn the COOK/PUMP switch back to the COOK position.

Again, “IS POT FILLED” shows in the display, followed by “1=YES 2=NO”. This time press  and unit resumes normal heating process.

CAUTION

When the fryer is heating, the shortening level must always be above the burner tubes. Failure to follow these instructions could result in a fire and/or damage to the fryer.

**3-8. CARE OF THE
SHORTENING**



FOLLOW THE INSTRUCTIONS BELOW TO AVOID SHORTENING OVERFLOWING THE FRYPOT, WHICH COULD RESULT IN SERIOUS BURNS, PERSONAL INJURY, FIRE, AND/OR PROPERTY DAMAGE.

1. To protect the shortening when the fryer is not in immediate use, the fryer should be put into the Idle Mode.
2. Frying breaded products requires filtering to keep the shortening clean. The shortening should be filtered at least twice a day; after lunch rush and at the end of the day.
3. Maintain the shortening at the proper cooking level. Add fresh shortening as needed.
4. Do not overload the baskets with product (20 lb (9.0 kg) max), or place product with extreme moisture content into baskets.



WITH PROLONGED USE, THE FLASHPOINT OF SHORTENING IS REDUCED. DISCARD SHORTENING IF IT SHOWS SIGNS OF EXCESSIVE SMOKING OR FOAMING. SERIOUS BURNS, PERSONAL INJURY, FIRE, AND/OR PROPERTY DAMAGE COULD RESULT.

**3-9. FILTERING
INSTRUCTIONS**

The Henny Penny gas 8 head fryer, Model OFG-391, must be cleaned and the shortening filtered at least twice daily; after lunch rush and at the end of the day.



Drain the shortening at 275° F (135° C) or less. The higher temperatures cause cracklings to burn on the steel frypot surfaces after the shortening has drained.

3-9. FILTERING
INSTRUCTIONS
(continued)



FILTER ONLY WHEN THE SHORTENING TEMPERATURE IS LESS THAN 275° F (135° C). FAILURE TO DO SO CAN RESULT IN SHORTENING OVERFLOWING THE FRYPOT, CAUSING SERIOUS BURNS, PERSONAL INJURY, AND/OR PROPERTY DAMAGE.

High volume cooking could cause the cold zone to fill quicker with cracklings and cleaning may be required more often. Part of the process involves removing cracklings from the cold zone of the frypot.

1. Turn COOK/PUMP switch to OFF position.
2. Make sure drain pan is under fryer and the filter union is tightened to the standpipe, coming out of the pan.



The filter pan must be as far back under fryer as it will go, and the cover in place. Be sure the hole in the cover lines up with the drain before opening the drain. Failure to follow these instructions causes splashing of shortening and could result in personal injury.

Surfaces of fryer and racks will be hot. Use care when filtering to avoid getting burned.

3. Remove cooking racks and carrier, and wipe bottom of lid. Tilt lid out of the way to clean frypot.
4. Pull drain handle towards you to open drain valve. The handle should point straight out to the front of the fryer. Use L-shaped brush to clean cracklings from the burner tubes and from sides and bottom of frypot as shortening drains. Use straight brush to push cracklings through drain opening in bottom of frypot if necessary, and to clean between the burner tubes and the frypot wall.

Shortening Stirrer

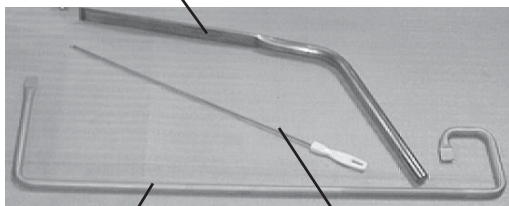

Drain Cleanout Rod

Small White Brush

3-9. FILTERING INSTRUCTIONS
(Continued)



BRUSH ALL CRACKLINGS FROM FRYPOT SURFACES AND THE COLD ZONE DURING THE FILTERING PROCESS. FAILURE TO DO SO CAN RESULT IN SHORTENING OVERFLOWING THE FRYPOT, WHICH COULD CAUSE SERIOUS BURNS, PERSONAL INJURY, FIRE AND/OR PROPERTY DAMAGE.

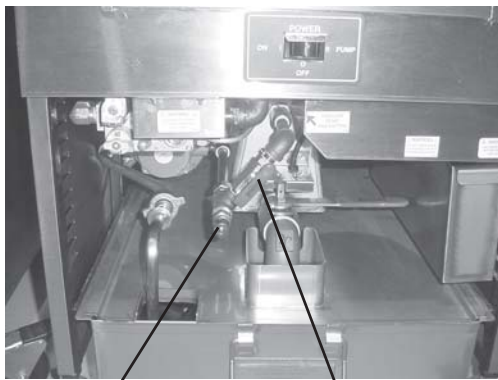

Male Fitting Filter Valve Handle

5. When all of the shortening has drained, scrape or brush the sides and bottom of the frypot, and swing drain valve handle to the closed position.
6. If an optional filter rinse hose is available on your fryer, the following cleaning procedure may be used, otherwise continue onto step 7.
 - a. Attach the filter rinse hose with its quick disconnect fitting to the male fitting, located next to the filter valve handle. Slide back the spring ring on the female side of the quick disconnect fitting and let it snap into place over the male half of the fitting.
 - b. Make sure the hose nozzle is pointed down into the bottom of the frypot and filter valve is in closed position. Move the COOK/PUMP switch to the PUMP position. Hold nozzle carefully to avoid excessive splashing.



Use care to prevent burns caused by splashing of hot shortening.

3-9. FILTERING INSTRUCTIONS **(Continued)**

- c. Rinse the frypot interior. Especially work on hard to clean areas, like the frypot bottom and burner tubes.
- d. After thorough rinsing with shortening, close the drain valve.
- e. Turn the COOK/PUMP switch to the OFF position.



ONLY CONNECT AND DISCONNECT THE FILTER RINSE HOSE WHEN THE MAIN POWER SWITCH IS IN THE OFF POSITION. ALSO, USE A DRY CLOTH OR GLOVE TO AVOID BURNS. FAILURE TO DO THIS COULD RESULT IN SEVERE BURNS FROM HOT SHORTENING SPRAYING FROM THE MALE FITTING.

- f. Detach the hose and raise the fitting end of hose high for a minute to allow the remaining shortening in the hose to drain into the frypot.
7. Turn COOK/PUMP switch to PUMP.
8. When all shortening has been pumped into frypot turn COOK/PUMP switch off.

3-10. CHANGING THE FILTER ENVELOPE

The filter envelope should be changed after 10-12 filterings, or whenever it becomes clogged with crumbs. Proceed as follows:

1. Move the COOK/PUMP switch to the OFF position.
2. Remove and empty the condensation drain pan.
3. Disconnect the filter union and remove the filter drain pan from beneath the frypot.



Use protective cloth or glove when disconnecting the filter union or severe burns could result.

If the filter pan is moved while full of shortening, use care to prevent splashing, or severe burns could result.

**3-10. CHANGING THE FILTER
ENVELOPE (Continued)**

4. Lift the filter screen assembly from the drain pan.
5. Wipe the shortening and crumbs from the filter drain pan. Clean the filter drain pan with soap and water. Thoroughly rinse with hot water.
6. Unthread the standpipe from the filter screen assembly.
7. Remove the crumb catcher and clean thoroughly with hot water.
8. Remove the filter clips and discard the filter envelope.
9. Clean the top and bottom filter screen with soap and water. Rinse thoroughly with hot water.

NOTICE

Be sure that the filter screens, crumb catcher, filter clips, and the standpipe are thoroughly dry before assembly of filter envelope as water will dissolve the filter paper.

10. Assemble the top filter screen to the bottom filter screen.
11. Slide the screens into a clean duster envelope.
12. Fold the corners in and then double fold the open end.
13. Clamp the envelope in place with the two filter retaining clips.
14. Replace the crumb catcher screen on top of the filter paper. Screw on the standpipe assembly.
15. Place complete filter screen assembly back into filter drain pan and slide pan back into place beneath the fryer.
16. Connect the filter union by hand. Do not use a wrench to tighten.
17. Slide the condensation drain pan back into place. The fryer is now ready to operate.

**3-11. LIGHTING AND
SHUTDOWN OF THE
BURNERS**

To light burner:

1. Turn COOK/PUMP switch to the OFF position.
2. Rotate gas valve knob clockwise to the OFF position and wait at least five(5) minutes before continuing to next step.
3. Rotate gas valve knob counter clockwise to the ON position.
4. Place the electrical COOK/PUMP switch to COOK position. The burner will light until shortening reaches a preset temperature.
5. Press desired product button after temperature is displayed.

To shutdown burner:

1. Turn COOK/PUMP switch to the OFF position.
2. Rotate gas valve knob to the OFF position.

This fryer is equipped with a grounded (earthed) cord and plug for your protection against shock, and should be plugged into a 3 prong grounded (earthed) receptacle. Do not cut or remove grounding prong.

3-12. FILTER PUMP MOTOR



Figure 3-3

The filter pump motor is equipped with a manual reset button, located on the rear of the motor, in case the motor overheats. Wait about 5 minutes before attempting to reset this protective device to allow motor to cool. Remove the access panel on the left side panel of the unit to reset the button. It takes some effort to push the reset, and a screwdriver can be used to help reset the button.



To prevent burns caused by splashing shortening, turn the unit's main power switch to the OFF position before resetting the filter pump motor's manual reset protection device.

3-13. CLEANING THE FRYPOT

After the initial installation of the fryer, as well as before every change of shortening, the frypot should be thoroughly cleaned as follows:

1. Turn the COOK/PUMP switch to OFF, and unplug unit from wall receptacle.



Moving the fryer or filter drain pan while containing hot shortening is not recommended. Hot shortening can splash out and severe burns could result.

The filter drain pan must be as far back under fryer as it will go, and the cover in place. Be sure the hole in the cover lines up with the drain before opening the drain. Failure to follow these instructions causes splashing of shortening and could result in personal injury.

2. If hot shortening is present in the frypot, it must be drained by slowly pulling the drain handle out towards you.
3. Close the drain valve and discard the shortening.
4. Raise lid, remove the racks and carrier from lid, and tilt lid back, so that the lid won't interfere with cleaning.

3-13. CLEANING THE FRYPOT
(Continued)

- Fill the frypot to the level indicators with hot water. Add 8 to 10 ounces of fryer cleaner (Henny Penny part number 12101) to the water and mix thoroughly.







Always wear chemical splash goggles or face shield and protective rubber gloves when cleaning the frypot as the cleaning solution is highly alkalie. Avoid splashing or other contact of the solution with your eyes or skin. Severe burns and possible blindness will result. Carefully read the instructions on the cleaner. If solution comes in contact with your eyes, rinse thoroughly with cool water and see a physician immediately.



CHEMICAL
SPLASH
GOGGLES



CHEMICAL
RESISTANT
GLOVES

- Turn the COOK/PUMP switch to COOK and enter the Clean-Out Mode by pressing and holding  until “CLEAN OUT?”, “1=YES 2=NO” shows in display. Press  to start Clean-Out Mode. The fryer displays “*CLEAN-OUT MODE*” and heats up to a preprogrammed temperature (195°F (91°C max.) then automatically begins a preset timed countdown. Use  , if necessary, to adjust the temperature and to keep cleaning solution from boiling over.
- Using the fryer brush (Henny Penny part number 12105) scrub the inside of the frypot, the lid frame, and around the counter-top of the fryer.



Watch the cleaning solution constantly to make sure it does not boil over causing damage to controls.

Do not use steel wool, other abrasive cleaners or cleaners/sanitizers containing chlorine, bromine, iodine or ammonia chemicals, as these will deteriorate the stainless steel material and shorten the life of the unit.

Do not use a water jet (pressure sprayer) to clean the unit, or component failure could result.

3-13. CLEANING THE FRYPOT
(Continued)

8. After cleaning, turn off the COOK/PUMP switch. Open the drain valve and drain the cleaning solution from the frypot into the filter drain pan and discard.
9. Close the drain valve and refill the frypot with plain hot water to upper level indicator line.
10. Add approximately 16 ounces of distilled vinegar and enter the Clean-Out Mode again (see step 6).
12. Using a clean brush, scrub the interior of the frypot and lid liner. This will neutralize the alkaline left by the cleaning compound.
13. Drain the vinegar rinse water and discard.
14. Rinse down the frypot, using clean hot water.
15. Thoroughly dry the filter drain pan, and the frypot interior.

NOTICE

Make sure the inside of the frypot, the drain valve opening, and all parts that come in contact with the new shortening are as dry as possible.

16. Replace the clean filter screen assembly in the filter drain pan and install under fryer.
17. Refill the fryer with fresh shortening

3-14. REGULAR MAINTENANCE

As in all food service equipment, the Henny Penny open fryer does require care and proper maintenance. The table below provides a summary of scheduled maintenance. The following paragraphs provide step-by-step maintenance procedures to be performed by the operator.

Procedure	Frequency
Filtering of shortening	Daily (at least twice a day)
Changing of shortening	As required
Changing the filter envelope	After 10-12 filterings or when clogged
Cleaning the frypot	Upon initial installation and every change of shortening
Checking/cleaning dilution box	Monthly-see Preventive Maint. Section
Cleaning the Nylatrons	Monthly-see Preventive Maint. Section
Lubricate lid rollers	Annually-see Preventive Maint. Section
Cleaning Blower Wheel	Annually-see Preventive Maint. Section
Inspect Counter Weight Cables	Annually-see Preventive Maint. Section

**3-15. PREVENTIVE
MAINTENANCE**



Before servicing the fryer:

- **Gas supply should be turned off to avoid fire or explosion.**
- **Electrical supply should be unplugged or wall circuit breaker turned off to avoid electrical shock.**

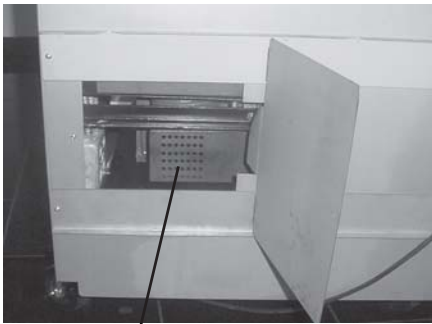

Dilution Box

Checking/Cleaning Dilution Box - Monthly

Cleaning the dilution box helps to ensure the unit operates efficiently and with few failures.

1. Make sure unit is off, and close and lock the lid.



Lid should be in locked down position. Failure to do so could result in personal injury.

2. Unscrew the wingnut on the lower left back access panel of the fryer, and remove the access panel. Clean the dilution box with a cloth or brush. Make sure the holes in the box are free of debris. Replace the back access panel when finished.



Depending on the breaching location and conditions within the kitchen area, the dilution box may need to be cleaned more often.

Cleaning the Nylatrons - Monthly

1. Spray Henny Penny biodegradable, food safe, foaming degreaser (part no. 12226) on Nylatrons.
2. Raise lid up and down several times to spread the degreaser.
3. Wipe Nylatrons to remove food soil, grease, and degreaser residue.



**3-13. PREVENTIVE
MAINTENANCE
Continued**

Inspect Counter-weight Cables-Annually

Henny Penny 8 head fryers use two cables in the counter-weight mechanism that helps in the raising and lowering of the lid. Cables should be visually inspected yearly, either as part of a planned maintenance program or during a routine service call. Cables more than 10 years old should be replaced regardless of inspection results.

NOTICE

If lid becomes difficult to operate, stop using the fryer and call for service. Cables need replaced.



Figure 1

1. Using a 3/8" socket, remove the 6 keps nuts around exterior of rear cover, shown in Figure 1.
2. Lift up on the rear cover and pull out at the bottom to clear threaded studs. Figure 2. (Removing top shroud makes it easier to remove the rear cover, but is not necessary.)



Figure 2



View of the counter-weights
with cover removed

**3-14. PREVENTIVE
MAINTENANCE
(Continued)**

Inspect Counter-weight Cable-Annually (continued)

3. Inspect the counter-weight cables. If cables have cracks in the jacket, missing pieces in the jacket, or other obvious signs of wear, call for service to have both cables replaced.

NOT OK - REPLACE

Cracks in jacket and obvious signs of wear.

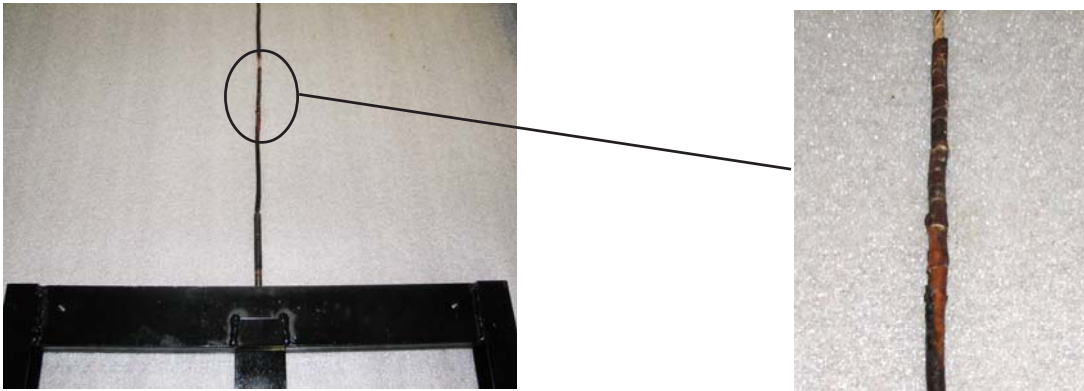

OK

No signs of cracking or wear.

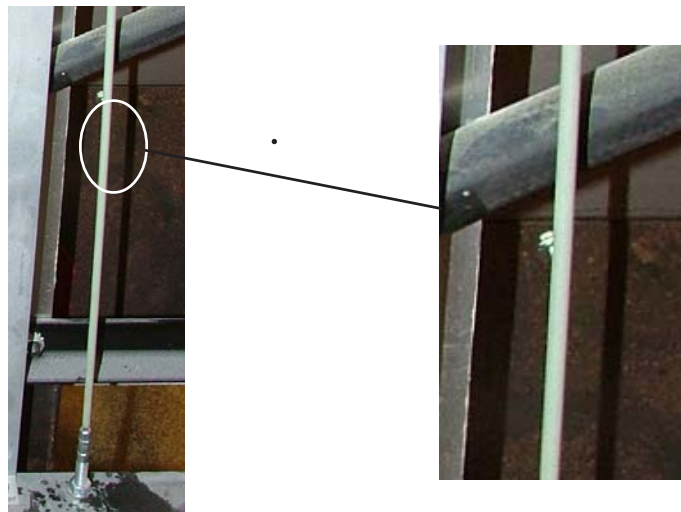

3-15. PREVENTIVE MAINTENANCE (Continued)



Lubricating Lid Rollers - Annually

The lid rollers, in the back of the fryer, should be lubricated at least once a year, to allow the lid easy movement.

1. Remove the back shroud of the fryer.
2. Using spindle lube, part number 12124, place a small amount of lube on both top and bottom rollers. Make sure to lube both left and right rollers.

Cleaning Blower Wheel - Annually

The blower wheel must be cleaned annually to ensure the unit operates efficiently and without failures.

Make sure unit is off, and close and lock the lid.



Lid should be in locked down position. Failure to do so could result in personal injury.

2. Remove the back shroud of the unit.
3. Remove the hose from the blower housing by sliding blower tube out of the bracket. See photo at left.
4. Clean the fins of the blower wheel, using a brush or straight blade screwdriver. Make sure the fins are clean of any debris.



Depending on the breading location and conditions within the kitchen area, cleaning the blower wheel may need to be done more frequently.

3-16. PROGRAMMING

1. Press and hold  for one second until “PROG” shows in the display, followed by “ENTER CODE”.
2. Enter code 1, 2, 3. “SELECT PRODUCT...PRESS PROG” scrolls across the display.





If no buttons are pressed within approximately 2 minutes while in the Program Mode, the controls will revert back to the Cook Mode.

3-16. PROGRAMMING
(Continued)

















3. Press and release the desired product button (1 to 10).

NOTICE





Press  to copy a product, erase a product, preset a product, erase all products, or preset all products.

4. Press and release . The name of that product shows in the display. Ex. “NAME“FRIES”.

Change Product Names



- a. Press and release  and  and the first letter, or digit, starts flashing.
 - b. Press and release  to change the flashing letter.
 - c. To continue to the next letter, press . Then press   to change this letter.
 - d. Repeat step c until up to 7 letters are entered.
 - e. Press and hold  to exit Program Mode, or press and release  until “PRELOAD” shows in display, to continue with Program Mode.
5. The Preload Mode allows the operator to drop large pieces first, with the lid up, before loading the rest of the product. The preload cycle always regulates to the Step 1 cook temperature. Press   to set a pre-load time, or press  if no pre-load is desired.
6. Press and release  and “1. COOK TIME” shows in the display along with the preset time. Press   to change the time. The time shows in minutes and seconds. Press and hold the buttons, and the time will jump by 5 second increments to a maximum of 59:59.
7. Press and release  and “1. TEMP” shows in the display, along with the preset temperature on the right side of the display. Press   to change the temperature. Press and hold the buttons and the temperature will jump by 5 degree increments to a max. of 380°F (193°C), and a min. of 190°F (88°C).





3-15. PROGRAMMING
(Continued)

8. Press and release  and “2. STEP 2 AT” shows in display, along with a step 2 time. If no step 2 is desired, set time to “0:00” and press . If a step 2 is desired, press   and set a time. Then press  to set the temperature.

NOTICE



Up to 10 steps can be programmed for a product, repeating the above step for each cooking step.

9. Press and release  and “ALARM – 1 AT 0:00” shows in the display. Press and release   to set an alarm. Ex: If a Cook Cycle was set at 3 minutes, and an alarm was to go off after 30 seconds into the Cook Cycle, “2:30” would be set in the display at this time. When the timer counts down to 2:30 the alarm sounds.

After the alarm time is set, press  and “ALARM” and “TYPE” flashes in the display, with the alarm type on the right side of the display. “TIME”, “SHAKE”, “STIR”, “ADD”, and “LID” can be set by pressing  . An alarm sounds and alarm type flashes, prompting the operator to shake the basket, stir the product, or add product. If “TIME” is selected, the time remaining flashes in the display. If “LID” is selected, “CLOSE LID” flashes in the display. The timer count-down pauses until the lid is closed and  is pressed to restart the timer.

NOTICE



Up to 4 alarms can be programmed. After the first one is set, the other alarms can be accessed by pressing  again.



10. Press and release  until “QUALITY TMR” shows in the display along with the preset holding time. Press and release   to adjust the holding time, up to 59:59.

NOTICE

To exit the Program Mode at any time, press and hold  for 2 seconds.

3-16. PROGRAMMING
(Continued)



11. Press and release  and “LOAD COMP” shows in the display along with the load compensation value. This automatically adjusts the time to account for the size and temperature of the cooking load. Press and release   to change this value to a max. of 20 and a min. of 0, or “OFF”. Preset at factory at 5.

12. Press and release  and “LCOMP REF” shows in the display (if load compensation is set to “OFF”, then “_ _ _” shows in display) along with the load compensation average temperature. This is your average cooking temperature for the products you cook. The timer speeds up at temperature above this setting and slows down at temperatures below this setting. Press and release   to change this value.

Or, to use the cooking setpoint temperature as the load compensation reference point, press  until “STEP-X”

and “TEMP” flashes in the display. Now for example, if the cooking temperature is 350°, the timer speeds up when the shortening temperature is above 350, and slows down when the temperature is below 350.

13. **Go to Idle after Done?**

Press and release  and “GO TO IDLE, AFTER DONE” shows in the display, along with “YES” or “NO”. Press   to toggle between YES and NO.



14. **Filter Cycle Mode (Optional)**

For “FILTER AFTER” to appear in the Product Program Mode, the Filter Tracking must be enabled in the Special Program Mode. You have the option to program “mixed” (each product has its own filter count) or “global” (all products have the same count).



Press .

3-16. PROGRAMMING
(Continued)

“2,Mixed”





- a. “FILTER AFTER” shows in the display, along with the preset number of Cook Cycles.
- b. Press and release   until the desired number of Cook Cycles between filters shows in the display. For example, if 4 is set for a product, each time that product is selected, it counts 1/4, or 25%. Then each time a product is cooked, the percentages add up until 100%, or more is reached. Then display shows “FILTER SUGGESTED”.

“3,GLOBAL”

- a. “FILTER INCL” shows in the display, along with “NO” or “YES”
- b. Press and release   to “YES” if that product is to be included in the filter count, or “NO” if it is not.

Copy/Erase Pre-set Products

Products and their setpoints can be copied from one menu location on the controller to another location, preset the controls to factory settings, or erase products and all their values.

1. Press and hold  for one second until “PROG” shows in the display, followed by “ENTER CODE”.
2. Enter code 1, 2, 3. “SELECT PRODUCT...PRESS PROG” scrolls across the display, followed by “DOWN” FOR OPTIONS”
3. Press  and “**OPTION**”, followed by “*1. COPY A PROD” shows in display. Press  again, each time, to view the following options:
 - *1. COPY A PROD
 - *2. ERASE A PROD
 - *3. PRESET A PROD
 - *4. ERASE ALL
 - *5. PRESET ALL
4. To select one of the above options, press  while the desired option shows in display. Selecting PRESET A PROD, or PRESET ALL PROD sets factory setpoints in those menu items.

Selecting PRESET A PROD, or PRESET ALL PROD sets factory setpoints in those menu items.



NOTICE

Press **INFO** at any time to exit the options menu, or wait 30 seconds and controller automatically exits.

3-16. PROGRAMMING
(Continued)

The following are examples of copying and erasing products:

Copying

Press  to select the presently displayed “COPY A PROD”

option. “COPY _ TO _” shows in display. The first set of “_” is blinking. Select the product you wish to copy from, for example, by pressing the  button:

“COPY 2 TO _” shows in display.

Next, press product you want to copy *to*, for example, by pressing



. The controller responds with a confirmation message:

“COPY 2 TO 0?”

“1=YES 2=NO”

Press  (YES) and the controller copies product #2 to the product #0 position (the #2 product is left intact) and the display shows “* COPIED *”, then returns to the “Select Prog Product” step with the #0 product already selected.

Press  (NO), or don't press any button for 20 seconds, the controller displays “X CANCELED X” and abandons the copy process. In this case no changes are made.

Erasing

On the “Select Prog Product” step, press . “** OPTIONS **” followed by “*1. COPY A PROD” shows in display.

Press  three more times to reach the “Erase All” option:

“*2. ERASE A PROD”

“*3. PRESET A PROD”

“*4. ERASE ALL”

Press  to select the presently displayed “ERASE ALL” option. The controller responds with a confirmation message:

“ERASE ALL PROD ?”

“1=YES 2=NO”

Press  (YES) to confirm that you want to erase all products back to “empty” values. The controller responds by erasing each product individually...

“ERASING 1”

“ERASING 2”

“ERASING 3”

“ERASING 4”

“ERASING 5”

Then briefly displays “* ALL ERASED *” and finally, returns to the “Select Prog Product” display.

3-17. SPECIAL PROGRAM MODE

The Special Program mode is used to set more detailed parameters listed below.

- SP-1** · Degrees Fahrenheit or Celsius
- SP-2** · Language: English, French, German, Spanish, and Portuguese
- SP-3** · System initialization
- SP-4** · Audio volume
- SP-5** · Audio tone
- SP-6** · Type of shortening to be melted - liquid, solid
- SP-7** · Idle Mode
- SP-8** · Filter Tracking
- SP-9** · Product buttons
- SP-10** · Clean-out minutes
- SP-11** · Clean-out temperature
- SP-12** · Nominal amps reading
- SP-13** · Amps reading low limit (percentage)
- SP-14** · Amps reading high limit (percentage)
- SP-15** · Program code change
- SP-16** · Usage code change
- SP-17** · Change shortening - A-Cook Cycles
- SP-18** · Change shortening - B-Hours

1. Press and hold  for 5 seconds until “L-2” and “LEVEL 2”, followed by, “SPPROG” and “ENTER CODE” shows in the display.
2. Enter code 1, 2, 3, and “SP- 1 “, “TEMP, UNITS” shows in the display.



NOTICE

If a bad code is entered, an alarm sounds and “BAD CODE” shows on the display. Wait a few seconds, the control reverts back to the Cook Cycle, and repeat the above steps.

To exit from the Special Program Mode at any time, press and hold  button for 2 seconds, or to roll back to

previous setting, press  .

Degrees Fahrenheit or Celsius (SP-1)

- a. Follow steps 1 and 2 above.
- b. The display flashes “SP- 1” and “TEMP, UNITS”, along with “F” or “C”. Press   buttons to toggle from “F” to “C”, or vice versa.



**3-17. SPECIAL PROGRAM
MODE (Continued)**

Language (SP-2)

- a. Follow steps 1 and 2 above.
- b. Press and release  button. “SP-2” and “LANGUAGE” flashes on the display, along with the language (Ex:” 1.ENGL”)
- c. To toggle to the desired language, press and release



System Initialization (SP-3)

This step resets the controls, but doesn’t erase product settings.

- a. Follow steps 1 and 2 above.
- b. Press and release  twice. “SP-3” and “DO SYSTEM INIT” flashes on the display, along with “INIT”.
- c. Press and hold . “INIT” shows on the display, a tone sounds, and “IN 3”, “IN 2”, “IN 1” flashes on the right side of the display. When “INIT” starts flashing on the left side of the display, release . When “DONE” shows on the display, the initialization is complete, and the controls now have factory preset parameters.



Audio Volume (SP-4)

The volume of the speaker can be adjusted.

- a. Follow steps 1 and 2 above.
- b. Press  3 times. “SP-4” and “AUDIO VOLUME” flashes on the display, along with the volume value.
- c. Press   to adjust the speaker volume; 10 the maximum value and 1 the minimum.

Audio Tone (SP-5)



The tone of the speaker can be adjusted.

- a. Follow steps 1 and 2 above.
- b. Press  4 times. “SP-5” and “AUDIO TONE (HZ)” flashes on the display, along with the tone value.
- c. Press   to adjust the tone of the speaker; 2000 the maximum, 50 the minimum.

**3-17. SPECIAL PROGRAM
MODE (Continued)**

Type of shortening to be melted - Liquid or Solid (SP-6)

The Melt Cycle can be set to the type of shortening being used.

- a. Follow steps 1 and 2 above.
- b. Press and release  5 times. “SP-6”
and “MELT CYCLE SELECT” flashes on the display,
along with “1=LIQ” or “2=SOLID”.
- c. Press   to toggle from one type to another.





CAUTION

The type of shortening being used in the fryer determines the amount of heat applied during the Melt Cycle. If the controls are set to the solid setting, less heat is applied to the shortening, than if the controls were set to liquid. Too much heat applied to solid shortening causes much smoking, and could cause a fire. Match this setting to the type of shortening being used at the time.









When using new shortening, it is recommended to melt the shortening on an outside source before placing shortening in the frypot. Unless burner tubes are completely covered in shortening, fire or damage to the frypot could result.

Idle Mode (SP-7)

A programmed Idle Mode allows the shortening temperature to drop to a lower temperature when not in use. This saves on the shortening and utilities.



- a. Follow steps 1 and 2 above.
- b. Press and release  6 times. “SP-7” and “IDLE
MODE ENABLED?” flashes in the display, along with
“NO” or “YES”.
- c. Press and release   to toggle from NO to YES,
or vice versa.
- d. With “YES” in the display, the Idle Mode is enabled.
Press and release  . “SP-7A” and
“IDLE SETPT TEMP” shows in the display, along with
the preset temperature.

**3-17. SPECIAL PROGRAM
MODE (Continued)**

- e. Change the idle setpoint temperature, by pressing  
- f. Press and release  . “SP-7B” and “AUTO-IDLE MINUTES” shows in the display, along with the preset time.
- g. Press   to set the minutes the cooker stays idle before the Auto-idle is enabled; 60 the maximum, OFF the minimum. Ex: “30” in the display means, if product is not cooked in that frypot for 30 minutes, the control automatically activates the idle setpoint temperature, programmed above.
- h. Press and release  . “SP-7C” and “GO IDLE AT MELT ?” shows in display.
- i. Press   to toggle from NO to YES, or vice versa. With “YES” in the display, the fryer automatically enters the Idle Mode once the Melt Mode is exited.

Filter Tracking Enabled (Sp-8)





The controls can be set to signal the operator when the shortening needs filtering. The Filter Tracking must be enabled to program the number of cook cycles between filtering procedures. (See Filter Cycles section 2-2.)

- a. Follow steps 1 and 2 above.
- b. Press and release  until “SP-8” and “FILTER TRACKING ENABLED” flashes on the display, along with “1,OFF”.
- c. To enable the filter tracking, press   to toggle the display from “1,OFF”, to “2,MIXED”, “3,GLOBAL”, or “4SCHEd”.

NOTICE





The Mixed setting allows the operator to set different amounts of Cook Cycles between filters, for each product. If the operator wants to have one setting for all products go to step h.

MIXED



- d. If “2,MIXED” is selected, press  and “SP-8A” shows in the display followed by “SUGGEST FILTER AT ...” and a value between 75% and 100%. Press and release   to change this value.
- e. Press  and “SP-8B” shows in the display followed by “LOCKOUT ENABLED?” and “YES” or “NO”.

Press and release   to choose yes or no.

**3-17. SPECIAL PROGRAM
MODE (Continued)**

- f. Press  and “SP-8C” shows in the display, if YES was chosen in step e. “FILTER LOCKOUT AT...” and a value between 100% and 200% shows in display. Press   to change this value.
- g. Press  and “SP-8D” shows in the display, followed by “LOCKOUT-HEAT OIL... and a temperature (preset at 300°F (149°C)). When a filter lockout occurs, the fryer heats up to this set temperature, and the display shows “FILTER LOCKOUT/WAIT”. Then once the set temperature is reached, “FILTER LOCKOUT/ “YOU *MUST* FILTER NOW” shows in display. Use to change this temperature setting.
- h. Now, go back to the Filter Cycle Mode step of the Programming Section, and program in the number of Cook Cycles between filtering.

GLOBAL

- i. If “3,GLOBAL” is selected, “SP-8A” shows in the display, and followed by “GLOBAL FILTER CYCLES”. The right side of the display shows a digit, 1 to 99. Press   to set the desired amount of Cook Cycles between filters.

NOTICE

In Cook Mode, the number of global Cook Cycles remaining shows in the center of the display.

Ex: “----- 5x -----”.

- j. Press  and “SP-8B” shows in the display followed by “LOCKOUT ENABLED?” and “YES” or “NO”.



Press and release   to choose yes or no

- k. Press  and “SP-8D” shows in the display, followed by “LOCKOUT-HEAT OIL... and a temperature (preset at 300°F (149°C)). When a filter lockout occurs, the fryer heats up to this set temperature, and the display shows “FILTER LOCKOUT/WAIT”. Then once the set temperature is reached, “FILTER LOCKOUT/ “YOU *MUST* FILTER NOW” shows in display. Use to change this temperature setting.

- l. Now, go back to the Filter Cycle Mode step of the Programming Section. Press  until “FILTER INCL” shows in the display. Each product must be set to “YES” to be included in the filter tracking.

**3-17. SPECIAL PROGRAM
MODE (Continued)**

SCHEDULE

m. If “4,SCHED” is selected, “SP-8A” shows in the display, and followed by “SCHEDULE”. Press the  and up 

to 4 different times of day can be programmed, by pressing

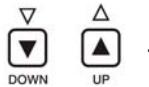

EX:



SP-8A “SCHEDULE” F1: 10.00A
 SP-8B “SCHEDULE” F2: 2.00P
 SP-8C “SCHEDULE” F3: 8.00P
 SP-8D “SCHEDULE” F4: - - - -



Unneeded times should be left at “- - - -”, otherwise, “Filter Suggested” shows in the display, prompting the operator to start filtering.

NOTICE

Cooking is still permitted during the “suggested” phase. However, if lockout is enabled, and the fryer still has not been filtered after one hour, then the controller activates lockout mode and prompts “FILTER LOCKOUT – YOU *MUST* FILTER NOW”.

n. Press  and “SP-8E” “SKIP IF LESS THAN...” shows in the display, followed by the number of loads between filters, ex: “LOAD 4”. In this example, if the suggested filter time occurs, before 4 loads have been cooked, then the filter operation is skipped. If more than 4 loads have been cooked, then “Filter Suggested” shows in the display. The numbers of loads can be set by pressing

o. Press  and “SP-8F” shows in the display, followed by “LOCKOUT ENABLED?” Press   to choose “YES” or “NO”.

p. Press  and “SP-8G” shows in the display followed by SP-8G “LOCKOUT - HEAT OIL...” and a shortening temperature, when reached, allows the operator to filter. Example, “LOCKOUT - HEAT OIL... 300F” means the display shows “FILTER LOCKOUT” “WAIT”, until 300F is reached, then display shows “FILTER LOCKOUT” “YOU *MUST* FILTER NOW”, and repeated high-low tones are activated. This prompts the user that it is now time to filter the shortening. Press   to change.

**3-17. SPECIAL PROGRAM
MODE (Continued)**

Product Buttons (Sp-9)

This mode allows you set up the way products are selected, and Cook Cycles started, in the cook mode.

a. Follow steps 1 and 2 above.



b. Press and release **PROG** until “SP-9” and “PRODUCT BUTTONS” flashes in the display.

c. When using the first option, “1,COOK”, pressing a product button displays that product and starts the Cook Cycle. When nothing is cooking, no product displays.

d. Press   to show the second option. If using “2,SELECT”, pressing a product button displays the product only. Press  to start the Cook Cycle.

Clean-Out Temperature (Sp-10)

This allows you to set the number of minutes of the Clean-Out Mode.

a. Follow steps 1 and 2 above.

b. Press  until “SP-10” and “CLEAN-OUT MINUTES” shows in display, along with the preset minutes.

c. Press   to change the number of minutes, up to 99.

Clean-Out Temperature (Sp-11)

This allows you to set the temperature of the Clean-Out Mode.

a. Follow steps 1 and 2 above.

b. Press  until “SP-11” and “CLEAN-OUT TNP” shows in display, along with the set temperature.

c. Press   to change the temperature, up to 212°F (100°C).

Nominal Amps Reading (SP-12)-not used on model 391

“SP-12”, “AMPS RDG, NOMINAL” should show on the left side of display, and “OFF” on the right side.

Amps Reading Low Limit (SP-13)-not used on model 391

“SP-13” and “AMPS RDG, LOW LIMIT” should show on the left side of display, and “OFF” on the right side.

Amps Reading High Limit (SP-14)-not used on model 391

“SP-14” and “AMPS RDG, HIGH LIMIT” should show on the left side of display, and “OFF” on the right side.

**3-17. SPECIAL PROGRAM
MODE (Continued)**

Program Code Change (SP-15)

This allows the operator to change the program code (factory set at 1, 2, 3) used to access Product Programming, Special Programming, Clock Set, Data Comm, and Heat Control Modes.

a. Follows steps 1 and 2 above.

b. Press  until “SP-15” and “CHANGE, MGR CODE, 1=YES” shows in display, along with “CODE”.

c. Press . “ENTER NEW CODE, P=DONE, I=QUIT” shows in display. Press product buttons with new code.

d. If satisfied with code, press . “REPEAT NEW CODE, P=DONE, I=QUIT, shows in display. Press same code buttons in step c.

e. If satisfied with code, press . *CODE CHANGE* shows in display.

f. If not satisfied with code, press  and *CANCELLED* shows in display, then reverts back to “SP-15” and “CHANGE, MGR CODE, 1=YES”. Then the above steps can be repeated.

NOTICE

Press and hold  at any time to exit Special Program Mode.

Usage Code Change (SP-16)

This allows the operator to change the reset usage code (factory set at 1, 2, 3) to reset the usage amounts of each product. See Review Usage step in Information Mode.



a. Follow steps 1 and 2 above.

b. Press  until “SP-16” and “CHANGE, USG CODE ? 1=YES” shows in display, along with “USAGE”.

c. Press , “ENTER NEW CODE, P=DONE, I=QUIT” shows in display. Press product buttons with new code.



d. If satisfied with code, press  “REPEAT NEW CODE, P=DONE, I=QUIT” shows in display. Press same code buttons in step c.

3-16. SPECIAL PROGRAM MODE (Continued)

- e. If satisfied with code, press . “*CODE CHANGE*” shows in display.
- f. If not satisfied with code, press  and “*CANCELLED*” shows in display, then reverts back to “SP-16” and “CHANGE USG CODE ? 1=YES”. Then the above steps can be repeated.



Change Shortening-A-Cook Cycles (SP-17)

The operator can set a reminder to filter the shortening, based on the number of Cook Cycles accumulated. The display shows “CHANGE OIL SOON” when the preset number of Cook Cycles has been met, “OFF” to 5000, increments of 10.

- a. Follow steps 1 and 2 above.
- b. Press  until “SP-17” and “CHANGE OIL’ A – COOK CYCLES” shows in display, along with a number of Cook Cycles.
- c. Press and release   to change the number of Cook Cycles.

Change Shortening-A-Cook Cycles (SP-18)

The operator can set a reminder to filter the shortening, based on the number of power-on hours accumulated. The display shows “CHANGE OIL SOON” when the preset number of hours has been met, “OFF” to 999 hours.

- a. Follow steps 1 and 2 above.
- b. Press  until “SP-18” and “CHANGE OIL’ B – HOURS” shows in display, along with a number of hours.
- c. Press and release   to change the number of power-on hours.

NOTICE

Once the shortening is filtered, to clear the display of “CHANGE OIL SOON” (SP-17 & SP-18), reset the review usage data in the Information Mode. See Information Mode section of this manual.

Press and hold  t any time to exit Special Program Mode.

3-18. DATA LOGGING, HEAT CONTROL, TECH MODE, AND STAT MODE

The Data Logging, Heat Control, Tech and Stat Modes are advanced diagnostic and program modes, mainly for Henny Penny use only. For more information on these modes, contact the Service Department at 1-800-417- 8405, or 1-937-456-8405.

3-19. INFORMATION MODE

This mode gathers and stores historic information on the fryer and operator's performance. Press  and  at the same time

and “*INFO MODE*” shows on display. Press  or 

to access the steps and press  to view the statistics within each step. Information Mode is intended for technical use, but the operator can view the following information:

1. **E-LOG** - last 10 errors and time they occurred
2. **LAST LOAD** - information about the most recent Cook Cycle, or the cycle presently in progress
3. **DAILY STATS** - information for the last 7 days.
4. **REVIEW USAGE**- information accumulated since the last time this data was manually reset
5. **INPA VHDSF PM.PM** - provides test of fryer inputs
6. **OUTP** - shows the state of heater and pressure
7. **OIL TMP** - temperature of shortening
8. **CPU TMP** - temperature of PC board
9. **ANALOG** - status of controller's a-to-d converter

NOTICE

Press and hold  to exit Information Mode at any time, or after 2 minutes, controls automatically exit back to normal operation.

1. E-LOG (error code log)

Press  and “1A” (date & time) “*NOW*” shows in display. This is the present date and time.

Press  and if a error was recorded, “1B” (date, time, and error code information) shows in display. This is the latest error code that the controls recorded.

Press  and the next latest error code information can be seen. Up to 10 error codes (1B to 1K) can be stored in the E-LOG Section.

Press  to continue to LAST LOAD.

3-19. INFORMATION MODE
(Continued)

2. LAST LOAD

Press  to view the following information from the most recent Cook Cycle.



FUNCTION	DISPLAY EX:
Time of day the last cook cycle was started	STARTED 10.25A
Product (Last product cooked)	PRODUCT -2-
Ready? (Was fryer Ready before start?)	READY? YES
Stopped: Time remaining, or secs past Done	*DONE* + 9 SECS
Actual Elapsed Cook Time (real seconds)	ACTUAL TIME 7:38
Programmed Cook Time	PROG TIME 7:00
Actual Time vs. Prog Time (Percentage)	ACT / PROG 109%
Max Temp during cook cycle	MAX TEMP 327°F
Min Temp during cook cycle	MIN TEMP 313°F
Avg Temp during cook cycle	AVG TEMP 322°F
Heat On (percentage) during cook cycle	HEAT ON 73%

Only if Presently Cooking:

Present cook step, setpoint, and time rem.	STEP 1:325°F 6:47
Actual Oil Temp., Deg below Load Comp Avg, present Stretch Time (real secs/ck sec)	313°F LC-12° 1.06

Press  to continue to DAILY STATS.

3. DAILY STATS (reset each day)

Press  to view the following operation information for any of the last 7 days. Press  to select which day.

FUNCTION	DISPLAY EX:
Day this data was recorded for	TUE* APR-30
Number of Hours:Minutes the fryer was on	TUE* ON HRS 13:45
Number of times oil was filtered that day	TUE* FILTERED 3
Total number of cook cycles that day	TUE* TOTAL CK 38
Cook Cycles stopped before "DONE" that day	TUE* QUIT COOK 4
Cook Cycles for Product #1	TUE* COOK -1- 17
Cook Cycles for Product #2	TUE* COOK -2- 9
Cook Cycles for Product #3	TUE* COOK -3- 5
Cook Cycles for Product #4	TUE* COOK -4- 0
Cook Cycles for Product #5	TUE* COOK -5- 0
Cook Cycles for Product #6	TUE* COOK -6- 6
Cook Cycles for Product #7	TUE* COOK -7- 0
Cook Cycles for Product #8	TUE* COOK -8- 0
Cook Cycles for Product #9	TUE* COOK -9- 1
Cook Cycles for Product #0	TUE* COOK -0- 0

Press  to continue to REVIEW USAGE.

3-19. INFORMATION MODE

(Continued)

4. REVIEW USAGE

Press  to view the accumulated information since the data was manually reset:

FUNCTION	DISPLAY EX:
Day the usage data was previously reset	SINCE APR-19
Number of hours the fryer was on	PWR ON HRS 165
Number of times oil was filtered	FILTERED 34
Total number of cook cycles	TOTAL CK 462
Cook Cycles stopped before "DONE"	QUIT COOK 4
Percentage of Cook Cycles before oil change	OIL WEAR -A- 73%
Percentage of hours before oil change	OIL WEAR -B- 47%
Cook Cycles for Product #1	COOKED -1- 193
Cook Cycles for Product #2	COOKED -2- 107
Cook Cycles for Product #3	COOKED -3- 58
Cook Cycles for Product #4	COOKED -4- 0
Cook Cycles for Product #5	COOKED -5- 13
Cook Cycles for Product #6	COOKED -6- 69
Cook Cycles for Product #7	COOKED -7- 0
Cook Cycles for Product #8	COOKED -8- 7
Cook Cycles for Product #9	COOKED -9- 15
Cook Cycles for Product #0	COOKED -0- 0
Reset usage data: Enter the Mgr Code (1, 2, 3 unless changed) on this step to zero out all the usage information.	RESET USG/ ENTER CODE----

Press  to continue to INP A_CVHDSF_M

5. INP A CVHDSF_M

Press  to view the status of components and inputs. If the input signal is detected, an identifying letter is displayed (see below). If the signal is not detected, “_” is displayed.

With the COOK/PUMP switch in the COOK position, and all inputs detected, “A_CVHDSFPM.PM” shows in the display. See below for “definition” of codes.

A = COOK/PUMP in COOK position.

B = COOK/PUMP in PUMP position

C = Solenoid continuity; won't show on open fryers

V = Volts - 24 VAC detected

H = High Limit - If “H” is present, the high limit is good; if “H” is missing, the high limit is tripped (overheated) or faulty

D = DRAIN SWITCH-If “D” is present, the drain handle is closed; if “D” is missing, the drain is open or faulty

S = COOK/PUMP switch ON interlock circuit: If “S” is present, the COOK/PUMP switch is in the COOK position. If the “S” is missing, the COOK/PUMP is either off, failed, or wired incorrectly

F = FAN

P = PV-Detects output from PV terminal of ignition module

M = MV-Detects output from MV terminal of ignition module

3-19. INFORMATION MODE
(Continued)

Press  to view the specific status of each input. An underscore (“_”) indicates the input is not presently detected. A checkmark (“√”) indicates the signal is detecting a normal input. A blinking (“X”) indicates the signal is presently detected, but is detected as a half-wave (partially failed) input.

NOTICE

The V, H, D, S, F, P and M signals are wired in series. The first signal missing out of this sequence generally causes all signals to the right of it to be missing as well.

Press  to continue onto OUTP H* P_.

6. OUTP H* P_

This mode displays the status of components and outputs. If the output signal is detected, an identifying letter is displayed (see below), followed by an “*”. If the output is off, “_” is displayed.

“H” = Heat output

“P” = Pressure output (pressure fryers only)

If heat is on, “H*” shows in display. If heat is off, “H_” shows in display. If controls senses a problem with the heat output, “H*” shows in display, with the “*” flashing.

If pressure is on, “P*” shows in display. If pressure is off, “P_” shows in display. If controls senses a problem with the pressure output, “P*” shows in display, with the “*” flashing.

Press  to view the amp “DRAW” status of each output. “H √” and “P √” in the display means the amps are good. A flashing “X” behind the H or P means too much current.

Press  to view the No Connect/Ground (“NC/GND”) status of each output. This monitors a possible problem with the relays on the output PC board.

“H √” and “P √” in the display means everything on the output PC board is good. A flashing “X” behind the H or P means a problem exists.

Press  to view the outputs and inputs (see step 10) together.

3-19. INFORMATION MODE
(Continued)

Press  and “6. PMP_ AIR_” shows in display.

Press  to view the amp “DRAW” status of the pump motor output and air valve output. “PMP ✓” and “AIR ✓” in the display means the amps are good. A flashing “X” behind the “PMP” or “AIR” means too much current.

Press  to view the No Connect/Ground (“NC/GND”) status of each output. This monitors a possible problem with the relays on the output PC board.

Press  to continue onto the OIL TMP reading.

7. OIL TMP

This step shows the present peanut oil temperature. The display shows “7. OIL TMP (temp.)”.

Press  to continue onto the CPU TMP reading.

8. CPU TMP

This step shows the present PC board temperature.

Press  to continue onto the ANALOG reading.

9. ANALOG <1> 2.86V

This step displays the present status of any channel of the controller’s a to d converter. This feature may be useful to a technician troubleshooting a problem with the fryer or controller.

The displayed value can be toggled between volts and bits by pressing  If the displayed value has a decimal point,

it is voltage (0 to 5 VDC). If no decimal point is shown, the value is a-to-d bits (0 - 4095).

NOTICE

Press and hold  to exit Information Mode at any time, or after 2 minutes, controls automatically exit back to normal operation.

SECTION 4. TROUBLESHOOTING

4-1. TROUBLE SHOOTING GUIDE

Problem	Cause	Correction
Power switch on but fryer completely inoperative	<ul style="list-style-type: none"> • Open circuit 	<ul style="list-style-type: none"> • Fryer plugged in • Check breaker or fuse at wall
Shortening not heating	<ul style="list-style-type: none"> • Drain valve open • High temperature limit tripped 	<ul style="list-style-type: none"> • Close drain valve • Reset high temperature limit; see Operating Components Section
Foaming or boiling over	<ul style="list-style-type: none"> • See Boil-Over chart on fryer and beginning of Operation Section in this manual 	<ul style="list-style-type: none"> • Follow boil-over procedures from chart
Shortening not draining	<ul style="list-style-type: none"> • Drain valve clogged 	<ul style="list-style-type: none"> • Push cleaning rod through open drain valve
Filter motor won't run	<ul style="list-style-type: none"> • Motor overheated 	<ul style="list-style-type: none"> • Reset motor; see Filter Motor Protector-Manual Reset Section
Product Color Not Correct: A. Too Dark	<ul style="list-style-type: none"> • Temperature too high • Breading to far in advance 	<ul style="list-style-type: none"> • Check temperature setting in the Program Mode • Bread product closer to frying period
B. Too Light	<ul style="list-style-type: none"> • Temperature too low • Fryer incorrect preheat • Wrong product button pressed 	<ul style="list-style-type: none"> • Check temperature setting in the Program Mode • Allow proper preheat time • Be sure to press the correct product to be cooked
C. Product Greasy	<ul style="list-style-type: none"> • Shortening old • Temperature too low • Frypot overloaded • Product not removed from frypot immediately after end of cycle 	<ul style="list-style-type: none"> • Replace shortening • Check temperature setting in the Program Mode • Reduce cooking load • Remove product form frypot promptly

NOTICE

More detailed troubleshooting information is available in the Technical Manual, available at www.hennypenny.com, or 1-800-417-8405 or 1-937-456-8405.

4-2. ERROR CODES

In the event of a control system failure, the digital display will show an Error Message. These messages are coded: “E-4”, “E-5”, “E-6”, “E-10”, “E-15”, “E-20 A-D”, “E41”, “E-46”, “E-47”, “E-48”, E-70B, E-92. A constant tone is heard when an error code is displayed, and to silence this tone, press any of the product buttons.

DISPLAY	CAUSE	PANEL BOARD CORRECTION
“E-4”	Control board overheating	Turn switch to OFF position, then turn switch back to ON; if display still shows “E-4”, the board is getting too hot; check for signs of overheating behind the control panel; once panel cools down the controls should return to normal; if “E-4” persists, replace the control
“E-5”	Shortening overheating	Turn switch to OFF position, then back to ON; if display shows “E-5”, the heating circuits and temperature probe should be checked; once the unit cools down, the controls should return to normal; if “E-5” persists, replace the control
“E6-A”	Temperature probe open	Turn switch to OFF position, then turn switch back to ON; if display shows “E6”, have the temperature probe checked
“E6-B”	Temperature probe shorted	Turn switch to OFF position, then turn switch back to ON; if display shows “E6” have the temperature probe checked
“E-10”	High limit	Reset the high limit by manually pushing up on the red reset button; if the high limit does not reset, the high limit must be replaced; call Henny Penny’s Service Department
“E-15”	Drain switch	Close the drain, using the drain valve handle. If display still shows “E-15”, check drain microswitch per Technical Manual
“E-20 A”	Air pressure switch failure (stuck closed)	Press the timer button to try the ignition process again, and if “E-20 A” persists, call Henny Penny’s Service Department
“E-20 B”	Draft fan or air pressure switch failure (stuck open)	Press the Timer button to try the ignition process again, and if “E-20 B” persists, call Henny Penny’s Service Department
“E-20 C”	Ignition module failure	Press the Timer button to try the ignition process again, and if “E-20 C” persists, call Henny Penny’s Service Department
“E20 D”	Modules working but no ignition	Press the Timer button to try the ignition process again, and if “E-20 D” persists, call Henny Penny’s Service Department

4-2. ERROR CODES (Continued)

DISPLAY	CAUSE	PANEL BOARD CORRECTION
“E-41”	Programming failure	Turn switch to OFF position, then back to ON; if display shows “E-41”, the control should be re-initialized (see Programming Section); if the error code persists, replace the control panel
“E-46”	Eeprom memory write error	Turn switch to OFF position, then back to ON; if display shows “E-46”, the control should be re-initialized (see Programming Section); if the error code persists, replace the control panel
“E-47”	A-to-D failure (Analog converter chip)	Turn switch to OFF position, then back to ON; if display shows “E-47”, the control should be re-initialized (see Programming Section); if the error code persists, replace the control panel
“E-48”	Input system error (CPU can’t read buttons digital inputs)	Turn switch to OFF position, then back to ON; if display shows “E-48”, the control should be re-initialized (see Programming Section); if the error code persists, replace the control panel
“E-70-B”	Faulty power switch, or switch wiring; faulty I/O board	Have power switch checked, along with its wiring; have Input/Output board replaced if necessary
“E-92”	24 VAC fuse on I/O board open	Have components, in 24-volt circuit (I.E., hi limit, drain switch) checked for shorts

GLOSSARY

HENNY PENNY OPEN FRYERS

air valve	a valve on the eight head fryer that allows air into the filter lines when the pump is on in the mixing mode on eight head fryers
airflow switch (gas fryers only)	a switch that senses the amount of airflow coming from the blower; if the airflow falls below a certain level, the switch cuts power to the gas control valve that shuts down the burners
blower (gas fryers only)	located on the rear of a gas fryer, the blower pulls flue gases out of the flue and provides the proper amount of air to the burner tubes for efficient combustion
breeding	a flour and seasoning mixture used to coat the product prior to frying
burner assembly (gas fryers only)	an assembly on gas fryers that houses the pilot light which ignites the gas that heats the fryer
burner tubes (gas fryers only)	the tubes through which heated air is forced to heat the shortening
carrier	a wire frame inside the eight head frypot that holds five racks of product during the cook cycle
casters	the wheels on bottom of the fryer that allow the unit to roll; casters should be locked when unit is in use and not being moved; casters may be adjusted to help level the fryer
cleaning solution	an agent used to clean the frypot; see recommended cleaning procedures
cold zone	an area in the bottom of the frypot where shortening is cooler than the area above; the zone allows the crumbs to settle without burning
cook cycle	a programmed cycle that cooks a particular product at a preselected temperature and for a preselected time
cooking load	the amount of product cooked during a cook cycle
counterweight	the weights shipped with the fryer that, when installed in the counterweight assembly, enable the eight head fryer lid to lift easily
counterweight assembly	an assembly of weights and cables that enable the eight head fryer lid to lift easily
cover	a protective lid for the frypot when fryer is not in use
cracklings	the crumbs of breading that come off the product during a cook cycle
crumb catcher	the part of the filter assembly on four head fryers that filters crumbs out of the shortening before the shortening is pumped back into the frypot

data plate	a label or plate located on the right side panel of the fryer that indicates the fryer type, serial number, warranty date, and other information
drain handle	the handle used to open and close the drain valve
drain interlock switch	a microswitch that automatically shuts off the fryer heat in the event the drain valve is inadvertently opened while the fryer power switch is in the ON position
drain valve	a valve that allows the shortening to drain from the frypot into the filter drain pan; the fryer power switch should be in the OFF position before the drain valve is opened; the drain valve should remain closed at all other times
dumping table	a table onto which the cooked product is dumped after removal from the fryer frypot
fill lines	the four lines marked on the interior real wall of the frypot that show the proper shortening level (<i>also referred to as level indicator lines</i>)
filter clips	the clips are the part of the filter screen assembly that holds the filter envelope closed
filter drain pan	a pan that slides under the fryer into which shortening is drained
filter envelope	a fiber envelope into which the filter screen is placed; the end of the envelope is folded and held closed with filter clips; a part of the filter screen assembly
filter pan dolly	an optional transport cart for the filter drain pan
filter pump motor	the motor that powers the filtering system
filter screen assembly	an assembly that filters the shortening as it is pumped from the frypot; the assembly is made up of two filter screens, a filter envelope, two filter clips, and a crumb catcher (<i>Note: eight head fryers have two filter screens with no crumb catcher</i>)
filter union	the threaded connection between the fryer and the filter system that can be connected or released without tools
filter valve	the valve that must be opened to pump shortening back into the frypot during the filter cycle (<i>Models OFE-320, and 340</i>)
flame sensors (<i>gas fryers only</i>)	the sensors that shut off the gas supply to gas fryers if the pilot lights go out or do not light
fryer brush	a brush included with the fryer used to scrub the inside of the frypot
frypot	the interior portion of the fryer that holds the shortening and the product while cooking
frypot collar	the top flat surface area around the fryer lid

gas control valve (<i>gas fryers only</i>)	an automatic dual controller that controls gas to both pilot lights and gas pressure to burners on fryers; if either pilot light goes out, the controller shuts off the gas to the other pilot light
gas valve knob (<i>gas fryers only</i>)	the knob that opens and closes the gas control valve
gas pressure regulator (<i>gas fryers only</i>)	a device located on the gas control valve that regulates the gas pressure; the pressure specifications are preset at the factory
heat indicator	the light that illuminates when the shortening is being heated; the light goes off when the preset shortening temperature has been achieved
heating elements	the coils located inside the frypot on electric fryers that heat the shortening
high limit	a temperature control that opens and shuts off the heat to the frypot if it senses shortening temperature in excess of 420°F (212°C)
ignition modules	two modules that send electrical energy to the spark igniters that ignite the pilot lights on gas fryers
L-shaped brush	a brush included with the fryer that is used to clean around the burner tubes and heating elements
landing table	another name for a dumping table (<i>see dumping table</i>)
level indicator lines	the lines marked on the interior rear wall of the frypot that show the proper shortening level (<i>also referred to as fill lines</i>)
lid assembly	an assembly comprised of lid, lid handle, and lid latch which raises and lowers product into shortening on eight head fryers
lid handle	a handle that is attached to the lid and is used to lower the lid into contact with the frypot; the handle is then pulled forward and pushed down to lock the lid in place (<i>see lid latch</i>)
lid latch	a mechanical catch on the front of the fryer lid that engages a bracket located on the front of the frypot; the latch holds the lid down
manual shutoff valve (<i>gas fryers only</i>)	a valve located between the fryer and the wall that shuts off the flow of gas from the supply line; this is not the main shutoff valve for the store
melt cycle	a heat mode that cycles on and off to slowly melt the shortening when the power switch is on and the shortening temperature is below a certain temperature; the melt cycle prevents scorching of the shortening
pilot orifice (<i>gas fryers only</i>)	a controlled opening for the pilot light located on the burner assembly
pilot light (<i>gas fryers only</i>)	a small flame that remains burning even when the fryer is not in use; the flame ignites the gas when the fryer is turned on

power/pump switch	a three-way switch located on the front control panel of the fryer that serves as an off/on switch and a filter switch
product	a food item cooked in the fryer
rack	the wire grid that slides into the carrier to hold product during the cook cycle
setpoint	a preset cooking temperature; the setpoint is a programmable feature
shortening mixing system	an automatic system on eight head fryers that periodically uses the filter pump to mix the shortening in the frypot to prevent an accumulation of moisture to minimize the boiling action in the frypot
shortening shuttle	optional equipment used for shortening disposal
sift breading	the process of removing clumps from breading
spark igniters (gas fryers only)	the igniters that create a spark to ignite the pilot lights on gas fryers (see <i>ignition modules</i>)
standpipe	the pipe through which oil is pumped back into the frypot after the filtering process is complete
standpipe assembly	the pipe and fittings that are part of the shortening filtering process
straight brush	a brush that is included with the fryer that is used to clear the drain in the bottom of the frypot
temperature probe	a round probe that is located in the inside of the frypot that measures the temperature of the oil in the frypot; the temperature probe communicates with the control panel
thermal protector	overheat protection switch for the filter motor that must be manually reset if tripped



Henny Penny Corporation
P.O.Box 60
Eaton, OH 45320

1-937-456-8400
1-937-456-8402 Fax

Toll free in USA
1-800-417-8417
1-800-417-8434 Fax

www.hennypenny.com

* FM05 - 025 - , * Henny Penny Corp., Eaton, Ohio 45320, Revised 9-9-13