



# OPERATOR'S M A N U A L

## PRESSURE FRYER (Electric)

### MODEL

**PFE-590**

**PFE-592**



**HENNY PENNY**  
Engineered to Last

REGISTER WARRANTY ONLINE AT [WWW.HENNYPENNY.COM](http://WWW.HENNYPENNY.COM)



# HENNY PENNY

## 8 HEAD ELECTRIC PRESSURE FRYER

### SPECIFICATIONS

Height	61" (155 cm)
Width	24" (61 cm)
Depth	41¾" ( 107 cm)
Floor Space	Approximately 7 sq. ft. (.65 sq. m.)
Pot Capacity	8 head of chicken - 22 lbs. (9.9 kg) 100 lbs. shortening (45 Kg.)
Electrical	208 VAC, 3 Phase, 50/60 Hz, 17 KW, 47.2 Amps 240 VAC, 3 Phase, 50/60 Hz, 17 KW, 40.9 Amps 200 VAC, 3 Phase, (Delta), 50/60 Hz, 17 KW, 49.1 Amps 240 VAC, 3 Phase, (Delta), 50 Hz, 17 KW, 40.9 Amps 380 VAC, 3 Phase, 50 Hz, 17 KW, 25.8 Amps 415 VAC, 3 Phase, 50 Hz, 17 KW, 23.7 Amps 400 VAC, 3 Phase, 50 Hz, 17 KW, 24.6 Amps
Heating	Two 8,500 watt electric immersion elements
Shipping Weight	Approximately 758 lbs. (344 kg.)

### NOTICE

A data plate, located on the back shroud behind the lid, gives the information of the type of fryer, serial number, warranty date, and other information pertaining to fryer. Also, the serial number is stamped on the outside of the frypot. See figure below.

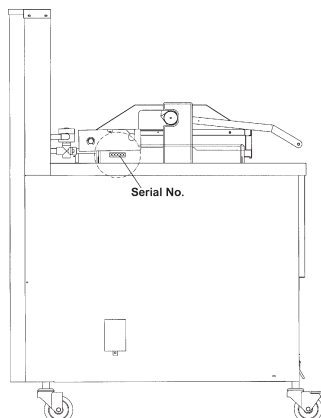

## TABLE OF CONTENTS

Section	Page
Section 1. INTRODUCTION .....	1-1
1-1 Pressure Fryer .....	1-1
1-2 Proper Care .....	1-1
1-3 Assistance .....	1-1
1-4 Safety .....	1-2
Section 2. INSTALLATION .....	2-1
2-1 Introduction .....	2-1
2-2 Unpacking .....	2-1
2-3 Selecting the Fryer Location .....	2-5
2-4 Leveling the Fryer .....	2-5
2-5 Ventilation of Fryer .....	2-6
2-6 Electrical Requirements .....	2-6
2-7 International Electrical Requirements .....	2-7
Section 3. OPERATION .....	3-1
3-1 Operating Components .....	3-1
3-2 Lid Operation .....	3-3
3-3 Melt Cycle Operation .....	3-4
3-4 Switches and Indicators .....	3-5
3-5 Filling or Adding Shortening .....	3-8
3-6 Basic Operation .....	3-9
3-7 Care of Shortening .....	3-11
3-8 Filtering Instructions .....	3-11
3-9 Changing the Filter Envelope .....	3-13
3-10 Cleaning the Frypot .....	3-14
3-11 Filter Pump Motor Protector-Manual Reset .....	3-15
3-12 Regular Maintenance Schedule .....	3-15
3-13 Preventive Maintenance .....	3-16
3-14 Programming .....	3-21
3-15 Special Program Mode .....	3-24
Section 4. TROUBLESHOOTING .....	4-1
4-1 Troubleshooting Guide .....	4-1
4-2 Error Codes .....	4-2
GLOSSARY .....	G-1



**SECTION 1. INTRODUCTION**

**1-1. PRESSURE FRYER**

The Henny Penny pressure fryer is a basic unit of food processing equipment which is used only in institutional and commercial food service operations.

**P-H-T**

A combination of pressure, heat, and time is automatically controlled to produce the optimum in a tasty, appealing product.

**Pressure**

Pressure is basic to this method of food preparation. The pressure is developed from the natural moisture of the food. The patented lid traps this moisture and uses it as steam. Because the steam builds rapidly, a greater part of the natural juices are retained within the food. An operation valve vents excess steam from the pot and maintains constant live steam pressure.

**Heat**

Heat generated is another important factor of the pressure fryer. Energy savings is realized due to the unit's short frying time, low temperature, and heat retention of the stainless steel frypot.

**Time**

Time is important because the shorter time involved in frying foods results in additional economies for the user. Foods are table ready in less time than it would take to fry them in a conventional open-type fryer.

**NOTICE**

As of August 16, 2005, the Waste Electrical and Electronic Equipment directive went into effect for the European Union. Our products have been evaluated to the WEEE directive. We have also reviewed our products to determine if they comply with the Restriction of Hazardous Substances directive (RoHS) and have redesigned our products as needed in order to comply. To continue compliance with these directives, this unit must not be disposed as unsorted municipal waste. For proper disposal, please contact your nearest Henny Penny distributor.



**1-2. PROPER CARE**

As in any unit of food service equipment, the Henny Penny pressure fryer does require care and maintenance. Requirements for the maintenance and cleaning are contained in this manual and must become a regular part of the operation of the unit at all times.

**1-3. ASSISTANCE**

Should you require outside assistance, call your local distributor in your area, or call 1-800-417-8405 or 1-937-456-8405.

The Henny Penny pressure fryer has many safety features incorporated. However, the only way to ensure a safe operation is to fully understand the proper installation, operation, and maintenance procedures. The instructions in this manual have been prepared to aid you in learning the proper procedures. Where information is of particular importance or safety related, the words DANGER, WARNING, CAUTION, and NOTICE are used. Their usage is described below.



**SAFETY ALERT SYMBOL** is used with DANGER, WARNING, or CAUTION which indicates a personal injury type hazard.



**NOTICE** is used to highlight especially important information.



*CAUTION used without the safety alert symbol indicates a potentially hazardous situation which, if not avoided, may result in property damage.*



*CAUTION used with the safety alert symbol indicates a potentially hazardous situation which, if not avoided, may result in minor or moderate injury.*



**WARNING** indicates a potentially hazardous situation which, if not avoided, could result in death or serious injury.



**DANGER INDICATES AN IMMINENTLY HAZARDOUS SITUATION WHICH, IF NOT AVOIDED, WILL RESULT IN DEATH OR SERIOUS INJURY.**

**HENNY PENNY**  
Engineered to Last<sup>™</sup>  
**1-5. SAFETY**  
**(Continued)**



Equipotential Ground Symbol



Waste Electrical and Electronic Equipment (WEEE) Symbol

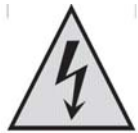

OR



Shock Hazard Symbols



OR



Hot Surface Symbols

## SECTION 2. INSTALLATION

### 2-1. INTRODUCTION

This section provides the installation and unpacking instructions for the Henny Penny PFE-590.

### NOTICE

Installation of this unit should be performed only by a qualified service technician.



**Do not puncture the fryer with any objects such as drills or screws as electrical shock or component damage could result.**

### 2-2. UNPACKING INSTRUCTIONS

### NOTICE

Any shipping damage should be noted in the presence of the delivery agent and signed prior to his or her departure.

1. Cut and remove the plastic bands from the main box.
2. Remove the box lid and lift the main box off the fryer.
3. Remove corner packing supports (4).
4. Cut the stretch film from around the carrier/rack box and remove it from the top of the fryer lid.
5. Cut and remove the metal bands holding the fryer to the pallet.



**All counterweights must be loaded before unlatching lid, or personal injury could result.**

6. Remove the fryer from the pallet.



**Take care when moving the fryer to prevent personal injury. The fryer weighs approximately 758 lbs. (344 Kg).**

**HENNY PENNY**  
 Engineered to Last™  
**2-2. UNPACKING**  
**INSTRUCTIONS**  
**(Continued)**

7. Remove the counterweights from the pallet, which are strapped to the pallet, under the fryer.



*Do not drop. The counterweights weigh approximately 18 lbs. (8.1 kg.) each. Handle with care, or personal injury could result.*

8. Remove rear service cover.
9. Load the seven weights into the counterweight assembly. See page 2-4.
10. Replace rear service cover.



**To avoid personal injury and assure safe operation of unit, rear service cover must be in place.**

11. Cut warning tags from the lid assembly. The lid may now be unlatched.
12. Remove the accessories from inside the filter drain pan.
13. Prepare the deadweight valve for operation



The metal shipping support is placed within the deadweight assembly housing to protect the deadweight orifice and deadweight during shipment. This support must be removed prior to installation and start-up.

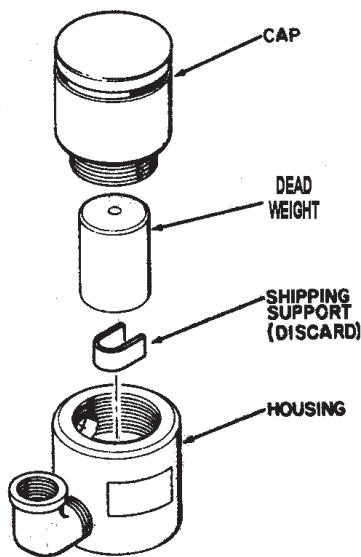

- A. Unscrew the deadweight cap.
- B. Remove the deadweight.
- C. Remove and discard the metal packing support.
- D. Clean the deadweight orifice with a dry cloth.
- E. Carefully place deadweight over deadweight orifice. Replace deadweight cap, finger tight.

13. Remove the protective paper from the fryer cabinet. Clean exterior surface with a damp cloth.

**Optional Ramp Unloading**

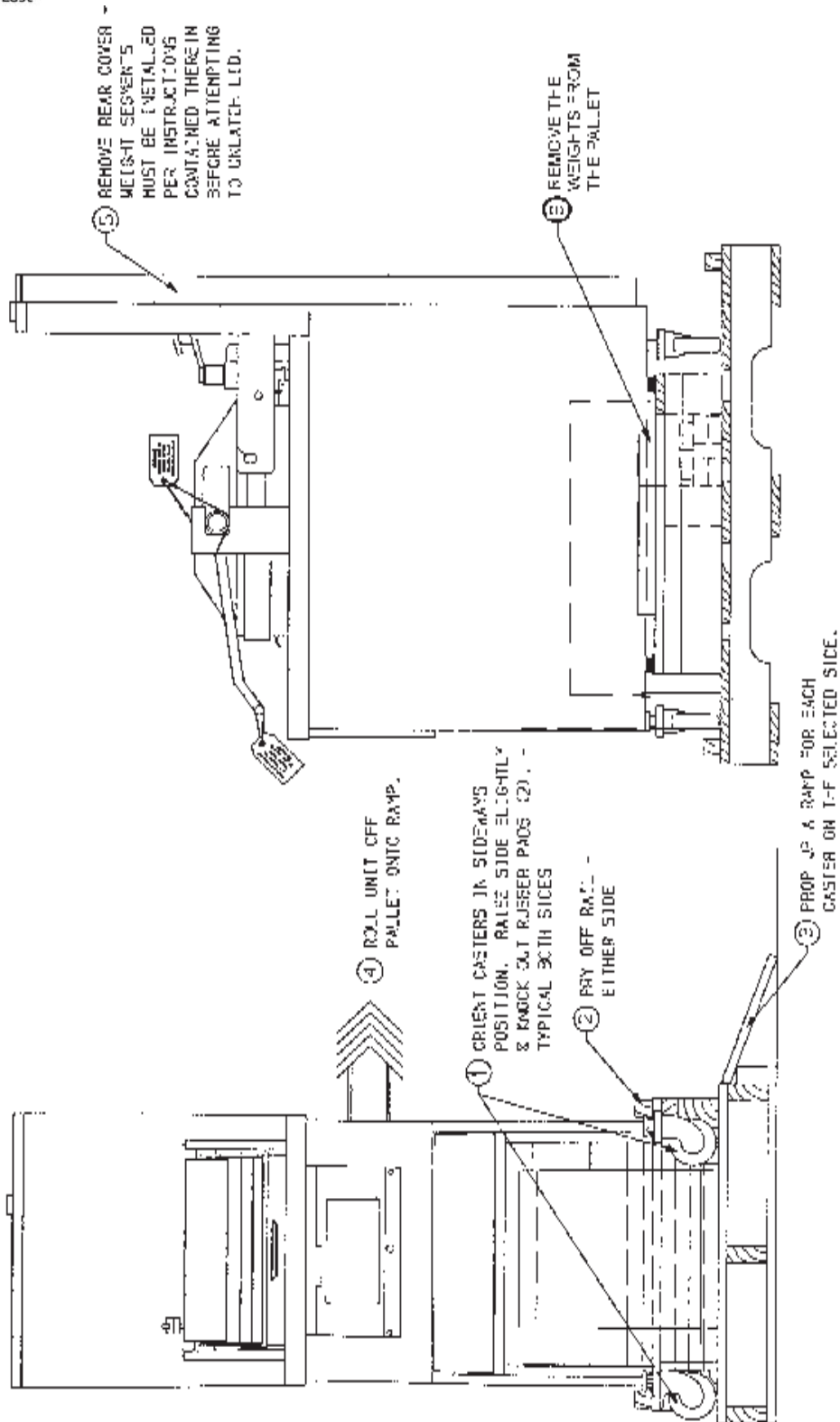

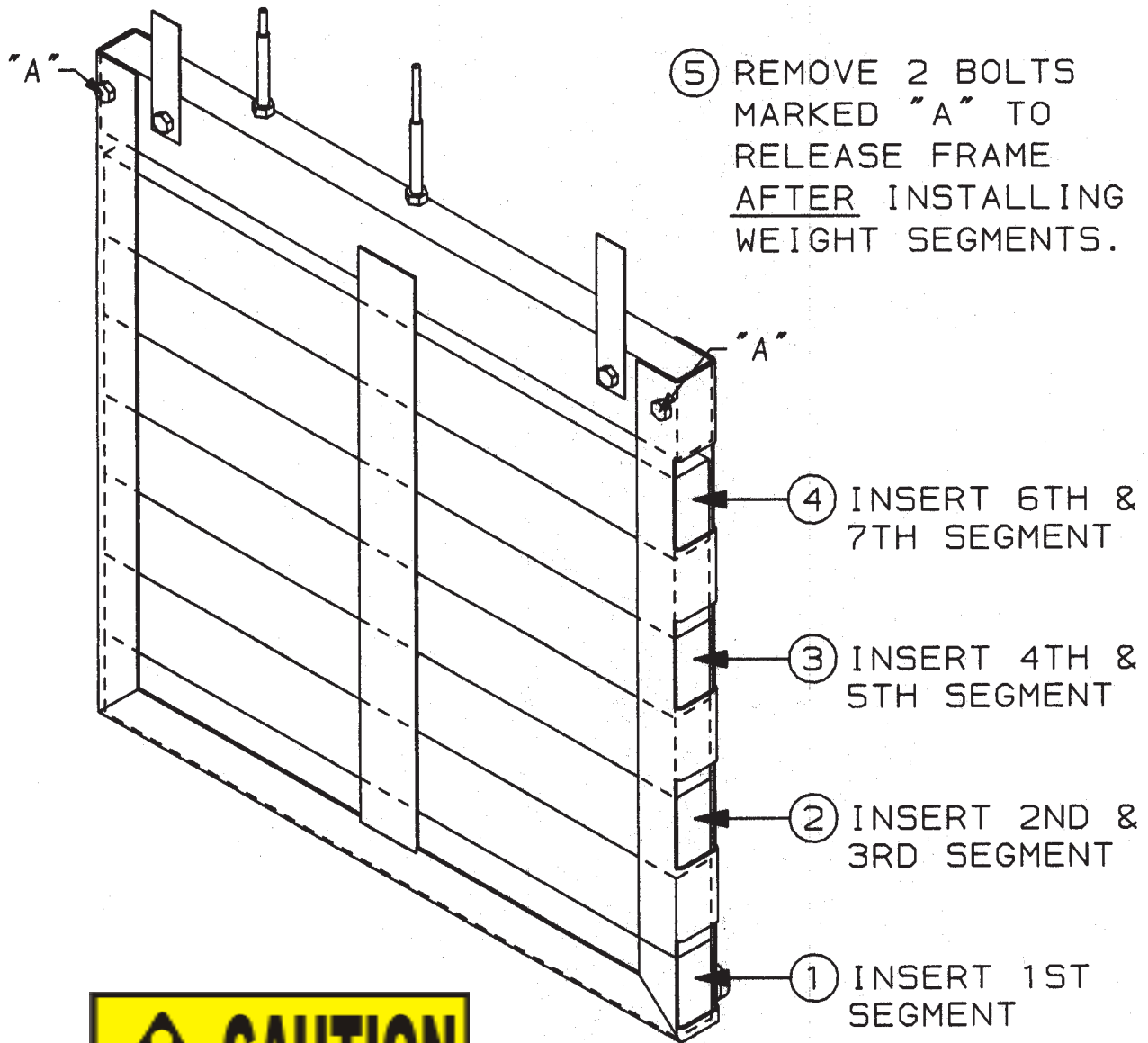

- \* EACH WEIGHT SEGMENT WEIGHS APPROXIMATELY 18 LBS. (8.1 KG) – HANDLE WITH CARE.
- \* ALL SEGMENTS ARE IDENTICAL.
- \* ALL SEGMENTS MUST BE INSTALLED AND SECURED IN THE FRAME BEFORE ATTEMPTING TO UNLATCH LID.

**HENNY PENNY**  
Engineered to Last™  
**2-3. SELECTING THE LOCATION**

The proper location of the fryer is very important for operation, speed, and convenience. Choose a location which will provide easy loading and unloading without interfering with the final assembly of food orders. Operators have found that frying from raw to finish, and holding the product in a warmer provides fast continuous service. Landing or dumping tables should be provided next to at least one side of the fryer. Keep in mind the best efficiency will be obtained by a straight line operation, i.e. raw in one side and finish out the other side. Order assembly can be moved away with only a slight loss of efficiency. To properly service the fryer, 24 inches (60.96 cm) of clearance is needed on all sides of the fryer. Access for servicing can be attained by removing a side panel.



*To avoid fire and ruined supplies, the area under the fryer should not be used to store supplies.*



**To prevent severe burns from splashing hot shortening, position and install fryer to prevent tipping or movement. Restraining ties may be used for stabilization.**

**2-4. LEVELING THE FRYER**

For proper operation, level the fryer from side to side and front to back, using level on the flat areas around the frypot collar.



**FAILURE TO FOLLOW THESE LEVELING INSTRUCTIONS CAN RESULT IN SHORTENING OVERFLOWING THE FRYPOT WHICH COULD CAUSE SERIOUS BURNS, PERSONAL INJURY, FIRE AND/OR PROPERTY DAMAGE.**

## 2-5. VENTILATION OF FRYER

The fryer should be located with provision for venting into adequate exhaust hood or ventilation system. This is essential to permit efficient removal of steam exhaust and frying odors. Special precaution must be taken in designing an exhaust canopy to avoid interference with the operation of the fryer. We recommend you consult a local ventilation or heating company to help in designing an adequate system.

### **NOTICE**

Ventilation must conform to local, state, and national codes. Consult your local fire department or building authorities.

## 2-6. ELECTRICAL REQUIREMENTS

The electric fryer requires 208 or 240 volt, three phase, 50/60 Hertz service. The power cord may be already attached to the fryer, or provided at installation. Check the data plate mounted just above the lid, on the left side of the back shroud, to determine the correct power supply.



**This fryer must be adequately and safely grounded (earthed) or electrical shock could result. Refer to local electrical codes for correct grounding (earthing) procedures or in absence of local codes, with The National Electrical Code, ANSI/NFPA No. 70-(the current edition). In Canada, all electrical connections are to be made in accordance with CSA C22.1, Canadian Electrical Code Part 1, and/or local codes.**

**To avoid electrical shock, this appliance must be equipped with an external circuit breaker which will disconnect all ungrounded (unearthed) conductors. The main power switch on this appliance does not disconnect all line conductors.**

A separate disconnect switch with proper capacity fuses or breakers must be installed at a convenient location between the fryer and the power source. It should be an insulated copper conductor rated for 600 volts and 90°C. For runs longer than 50 feet (15.24 m), use the next larger wire size.

**HENNY PENNY**  
 Engineered to Last™  
**2-7. INTERNATIONAL**  
**ELECTRICAL**  
**REQUIREMENTS**

Units being used outside the United States may not be shipped with the power cord attached to the unit because of the different wiring codes. The fryers are available from the factory wired for 208, 240, 380 and 415 volts, 3 phase, 50 Hertz service. A terminal block is mounted inside the fryer for the cable wiring. A decal on the inside of the right side panel will help in the wiring of the unit.

**NOTICE**

CE units require a minimum wire size of 4mm to be wired to the terminal block. If a flexible power cord is used, it must be HO7RN type.

To install the power cord, follow these procedures:

1. Remove the right side panel of the unit.
2. Install the cord, with a strain relief, to the junction box.
3. Attach the wires to the terminal block according to the wiring diagram on the side panel.
4. Pull the slack out of the cord and thread it down through the the clamp on the frame, at the rear, left leg of fryer. Then run the cable under the frame and out the rear of the fryer, so it doesn't interfere with the filter drain pan.



**The filter drain pan must be as far back under fryer as it will go, and the cover in place. Be sure the hole in the cover lines up with the drain before opening the drain. Failure to follow these instructions causes splashing of shortening and could result in personal injury.**

5. Wiring the fryer is now complete.

**HENNY PENNY**  
 Engineered to Last™  
**2-7. INTERNATIONAL**  
**ELECTRICAL**  
**REQUIREMENTS**  
**(Continued)**

**NOTICE**

- The supply power cords shall be oil-resistant, sheathed flexible cable, no lighter than ordinary polychloroprene or other equivalent synthetic elastomer-sheathed cord.
- It is recommended that a 30 mA rated protective device such as a residual current circuit breaker (RCCB), or ground fault circuit interrupter (GFCI), be used on the fryer circuit.



**(FOR EQUIPMENT WITH CE MARK ONLY!)**

**To prevent electric shock hazard this appliance must be bonded to other appliances or touchable metal surfaces in close proximity to this appliance with an equipotential bonding conductor. This appliance is equipped with an equipotential lug for this purpose. The equipotential lug is marked with the following symbol**



## BOIL-OVER PREVENTION IN HENNY PENNY COOKERS



**FAILURE TO FOLLOW THESE INSTRUCTIONS CAN RESULT IN SHORTENING OVERFLOWING THE FRYPOT WHICH COULD CAUSE SERIOUS BURNS, PERSONAL INJURY, FIRE AND/OR PROPERTY DAMAGE.**

- **THE SHORTENING MAY BE STIRRED ONLY DURING THE MORNING START UP PROCEDURE. DO NOT STIR THE SHORTENING AT ANY OTHER TIME.**
- **FILTER THE SHORTENING AT LEAST TWICE A DAY.**
- **FILTER ONLY WHEN “COOL” IS DISPLAYED.**
- **BRUSH ALL CRACKLINGS FROM FRYPOT SURFACES AND THE COLD ZONE DURING THE FILTERING PROCESS.**
- **MAKE SURE THE FRYER IS LEVEL.**
- **BE CERTAIN THE SHORTENING IS NEVER ABOVE THE UPPER FRYPOT LEVEL INDICATOR LINE.**
- **BE CERTAIN THAT THE GAS CONTROL VALVE AND BURNERS ARE PROPERLY ADJUSTED. (GAS UNITS ONLY)**
- **USE RECOMMENDED PRODUCT LOAD SIZE**

**FOR ADDITIONAL INFORMATION ON THESE INSTRUCTIONS, REFER TO THE HENNY PENNY OPERATOR MANUAL AND THE KFC STANDARDS LIBRARY.**

**FOR ASSISTANCE CALL THE HENNY PENNY SERVICE DEPARTMENT AT  
1-800-417-8405.  
or  
1-937-456-8405**



## SECTION 3. OPERATION

### 3-1. OPERATING COMPONENTS

<b>POWER/PUMP Switch</b>	A three way switch with center OFF position; move the switch to the position marked POWER to operate the fryer; move the switch to the position marked PUMP to operate the filter pump; certain conditions must be met prior to operation of the filter pump; these conditions are covered later in this section
<b>Frypot</b>	This reservoir holds the cooking shortening, and is designed to accommodate the heating elements, 8 head of product and an adequate cold zone for collection of cracklings
<b>Carrier</b>	This stainless steel carrier consists of five racks, containing the food product during and after frying (4 cook racks and 1 cover rack)
<b>Lid Gasket</b>	Provides the pressure seal for the frypot chamber
<b>Deadweight assembly</b>	The deadweight style operating pressure relief valve is used to maintain a constant level of steam pressure within the frypot; any excess steam pressure is vented through the exhaust stack; remove the deadweight cap, and clean the cap, weight, and deadweight orifice once a day. See Preventive Maintenance Section.



**Failure to clean the deadweight assembly daily could result in the fryer building too much pressure. Severe injuries and burns could result.**

<b>Safety Relief Valve</b>	An ASME approved spring loaded valve set at 14.5 psi (999 mbar); in the event the operation valve becomes obstructed, this safety valve releases excess pressure, keeping the frypot chamber at 14.5 psi (999 mbar); if this occurs, turn the COOK/ PUMP switch to the OFF position to release all pressure from the frypot
----------------------------	---



**If safety relief valve activates, turn main power switch to the OFF position. To avoid serious burns and injuries, have fryer serviced before next use.**



### 3-1. OPERATING COMPONENTS

(Continued)

#### Safety Relief Valve Ring



**DO NOT PULL THIS RING. SEVERE BURNS FROM THE STEAM WILL RESULT.**

#### Pressure Gauge

Indicates the pressure inside the frypot.

#### Solenoid Valve

An electromechanical device that causes pressure to be held in the frypot

The solenoid valve closes at the beginning of the Cook Cycle and opens automatically at the end of the Cook Cycle; if this valve becomes dirty or the teflon seat nicked, pressure will not build and it must be repaired per the Maintenance Section of the Technical Manual

#### Drain Valve

A two-way ball valve, normally in the closed position; turn the handle to drain the shortening from the frypot into the filter drain pan



**DO NOT OPEN THE DRAIN VALVE WHILE FRYPOT IS UNDER PRESSURE. HOT SHORTENING WILL EXHAUST, AND SEVERE BURNS WILL RESULT.**

#### Drain Interlock Switch

A microswitch that provides protection for the frypot in the event an operator inadvertently drains the shortening from the frypot while the main switch is in the COOK position; the switch is designed to automatically shut off the heat when the drain valve is opened

#### Condensation Drain Pan

The collection point for the condensation formed within the steam exhaust system; it must be removed and emptied periodically, usually daily

#### Shortening Mixing System

The unit is equipped with a shortening mixing capability to ensure the shortening is properly mixed to prevent an accumulation of moisture, causing boiling action in the frypot; the filter pump is activated by the controls, at preset intervals, to mix the shortening

#### Lid Latch

The fryer lid is equipped with a mechanical catch on the front of the lid which engages a bracket on the front of the frypot; this device holds the lid down while the lid is being locked into place, but is not meant to hold pressure in the frypot



### 3-1. OPERATING COMPONENTS (Continued)

#### High Temperature Limit

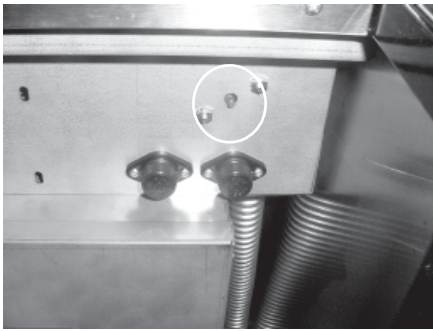

**Figure 3-1**

#### Air Valve

This is a safety component that senses the temperature of the shortening; if the temperature of the shortening exceeds 420°F (212°C), this control opens and shuts off the heat to the frypot; when the temperature of the shortening drops to a safe operation limit, the control must be manually reset by pressing the red reset button, located under the control panel, in the right, front of the fryer

Pumps air into the shortening, periodically, to keep the shortening at a uniform temperature; this only functions when the unit has been sitting idle for a period of time, and when heating from a cold start

#### Filter Drain Pan

The removable pan that houses the filter and catches the shortening when it is drained from the frypot; also used to remove and discard old shortening



**When hot shortening is in this pan, use extreme care to avoid burns.**

#### Filter Union

Connects the filter to the filter pump, and allows easy removal of the filter and drain pan

#### Fuses

A protective device which breaks the circuit when the current exceeds the rated value

### 3-2. LID OPERATION

To close lid:

1. Lower the lid until gasket comes into contact with the frypot and lock the lid in place with the lid latch.
2. Pull lid handle forward until it stops.
3. Lift up on the lid handle until it stops.
4. Bring lid handle out towards you until it stops.
5. Push lid handle down, locking lid in place.



**LID MUST BE LATCHED PROPERLY OR PRESSURIZED SHORTENING AND STEAM MAY ESCAPE FRYPOT. SEVERE BURNS WILL RESULT.**

### 3-2. LID OPERATION Continued)



**DO NOT LIFT HANDLE OR FORCE LID LATCH OPEN BEFORE PRESSURE GAUGE READS “0” PSI. ESCAPING STEAM AND SHORTENING WILL RESULT IN SEVERE BURNS.**

**TO AVOID SERIOUS PERSONAL INJURY, DO NOT OPERATE WITHOUT LID COVER IN PLACE AND ALL COMPONENTS INSTALLED.**

**TO AVOID SERIOUS PERSONAL INJURY, DO NOT TAMPER WITH ANY COMPONENT OF LID LOCKING MECHANISM.**

To open lid:

1. Gently raise handle until it stops.
2. Push handle back until it stops.
3. Lower handle.



*Lower the handle before attempting to raise the lid, or damage to the lid could result.*

4. Push handle back.
5. Unlatch the front lid latch.



If lid becomes difficult to operate, stop using the fryer and call for service. Cables need replaced.

### 3-3. MELT CYCLE OPERATION

If the shortening is below 185°F (85°C), with the POWER/PUMP switch in the POWER position, the fryer will enter the Melt Cycle. The shortening heats slowly to prevent scorching of the shortening. The heat cycles on and off to slowly melt the shortening. At 185°F (85°C), the heat stays on until 250°F (121°C), the Cool Mode, is reached. To exit the Cool Mode, press the EXIT COOL button.

See Filling and Adding Shortening Section.



### **3-4. SWITCHES AND INDICATORS**

Refer to image at end of this section.

#### **EXIT COOL Button**

After cooking, or filtering the shortening, the temperature automatically goes into the Cool Mode, which keeps shortening at a lower temperature; this temperature extends the shortening life and minimizes the time to heat the shortening for the next Cook Cycle; EXIT COOL button must be pressed to heat up to setpoint temperature



**ALTHOUGH THE DISPLAY WILL READ “COOL” DURING THE STANDBY MODE, THE SHORTENING IS HOT AND WILL CAUSE BURNS.**

#### **Product Selection Buttons**

Select the number of heads, or product, to be cooked by pressing the button below the menued item; shortening will then heat to drop temperature of that item

Pressing the same button again will begin the Cook Cycle; the indicator will change from “DROP” to counting down the cook time in minutes and seconds

At the end of the Cook Cycle, the alarm sounds and the indicator reads “DONE”; press the cycle button that is flashing, and the alarm will cease; the fryer will then reset to the Cool Mode



A Cook Cycle can be aborted at any time by pressing and holding the product button.

#### **Time/Temperature Display**

This is a 4 digit LED type display which shows the remaining cook time during Cook Cycles and also the shortening temperature on demand from the operator

#### **Heat Indicator**

Illuminates whenever the control calls for heat; when shortening temperature is reached, the heat light goes off



### **3-4. SWITCHES AND INDICATORS (Continued)**

#### **HI Temperature Indicator**

The display reads “HI” if the shortening temperature is 40° F above the setpoint

#### **Drop Indicator**

The display reads “DROP” when the shortening has reached the setpoint temperature (will read “DROP” 2° before setpoint and 4° above setpoint )

#### **Done Indicator**

The display reads “DONE” at the end of the Cook Cycle

#### **Temperature Button**

Allows the operator to read the temperature of the shortening while in a Cook Cycle

#### **SCAN Button**

Allows the operator to toggle through any running multiple timers

#### **FUNCTION Button**

Used in the programming of the controls

#### **EXIT FILL Button**

After filtering the fryer, if in the Filter Lockout Mode, the display reads “FILL” and the EXIT FILL button must be pressed

#### **Multiple Timers**

The control has the capability to run multiple timers; if more than one product is being cooked, a timer can be started by pressing more than one product button per Cook Cycle

### **NOTICE**

The products must have the same setpoints, and the pressure must be programmed off. See Programming Section.

**3-4. SWITCHES AND  
INDICATORS (Continued)**

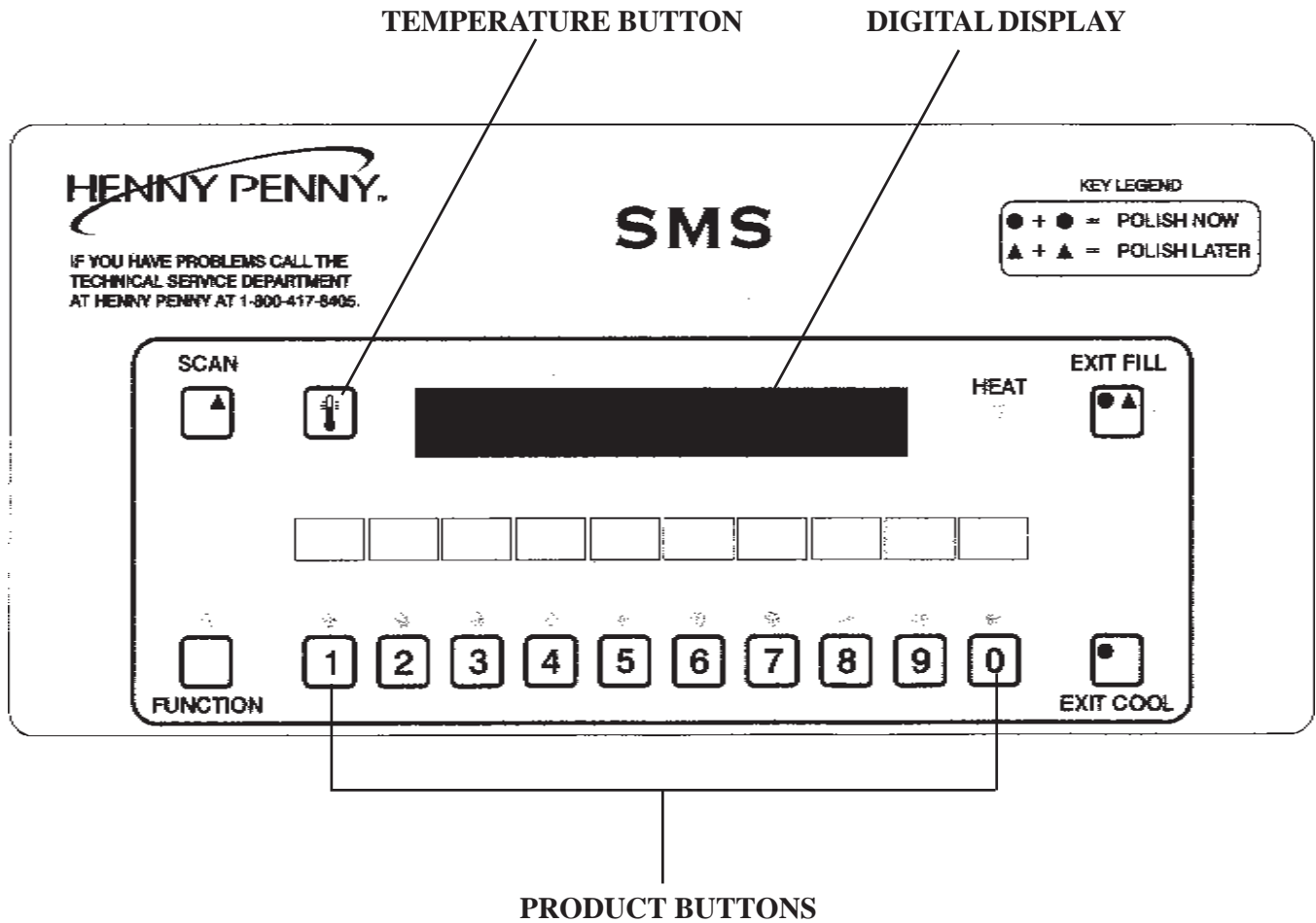

Figure 3-2

### **3-5. FILLING OR ADDING SHORTENING**

## **CAUTION**

*The shortening level must always be above the heating elements when the fryer is heating and at the frypot level indicators on the rear of the frypot (Figure 3-3). Failure to follow these instructions could result in a fire and/or damage to the fryer.*

*When using solid shortening, it is recommended to melt the shortening on an outside heating source before placing it in the frypots. The heating elements must be completely submerged in shortening. Fire or damage to the frypot could result.*

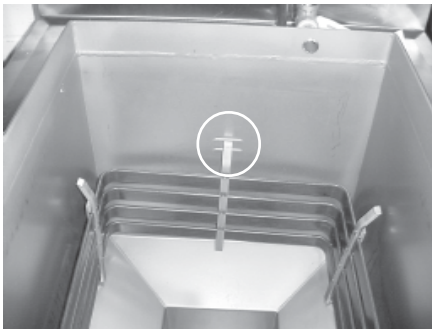

**Figure 3-3**

1. It is recommended that a high quality frying shortening be used in the pressure fryer. Some low grade shortenings have a high moisture content and cause foaming and boiling over.



**To avoid severe burns when pouring hot shortening into frypot, wear gloves and take care to avoid splashing.**

2. The electric model requires 100 lbs. (45 kg.) of shortening. The frypot has 2 level indicator lines inscribed on the rear wall of the frypot which show when the heated shortening is at the proper level. Figure 3-3.
3. Cold shortening should be filled to the lower indicator.



**BE CERTAIN THE SHORTENING IS NEVER ABOVE THE UPPER LEVEL INDICATOR LINE. FAILURE TO FOLLOW THESE INSTRUCTIONS CAN RESULT IN SHORTENING OVERFLOWING THE FRYPOT CAUSING SERIOUS BURNS, PERSONAL INJURY, FIRE AND/OR PROPERTY DAMAGE.**

For complete instructions, refer to KFC's Standards Library.



### **3-6. BASIC OPERATION**

Follow the procedure below on the initial start-up of the fryer, and each time the fryer is brought from a cold, or shut down condition, back into operation. These are basic, general instructions. Be sure to follow KFC's Standards Library when operating the fryer.

1. Make sure the frypot is filled to the proper level with shortening, to the lower level indicator.



**DO NOT OVERLOAD, OR PLACE PRODUCT WITH EXTREME MOISTURE CONTENT INTO THE RACKS. 22 LBS. (9.9 KG.) IS THE MAXIMUM AMOUNT OF PRODUCT PER FRYPOT. FAILURE TO FOLLOW THESE INSTRUCTIONS CAN RESULT IN SHORTENING OVERFLOWING THE FRYPOT WHICH COULD CAUSE SERIOUS BURNS, PERSONAL INJURY, FIRE AND/OR PROPERTY DAMAGE.**

2. Turn the POWER/PUMP switch to the POWER position and press the appropriate product button to select the amount of product to be cooked.
3. Stir the shortening as it's heating up from a cold start. Be sure to stir down into the cold zone.



**DO NOT STIR THE SHORTENING AT ANY OTHER TIME EXCEPT AT MORNING START-UP. FAILURE TO FOLLOW THESE INSTRUCTIONS CAN RESULT IN SHORTENING OVERFLOWING THE FRYPOT WHICH COULD CAUSE SERIOUS BURNS, PERSONAL INJURY, FIRE, AND/OR PROPERTY DAMAGE.**



### **3-6. BASIC OPERATION** **(Continued)**

4. Allow fryer to heat until digital display shows “DROP”.  
(Press the EXIT COOL button if the display shows COOL”)

## NOTICE

The heat cycles on and off approximately 10 degrees before the setpoint temperature, to help prevent overshooting the setpoint temperature. (proportional control)

5. Before loading product onto the racks, lower racks into the hot shortening to keep the product from sticking to the racks.
6. Slide racks of breaded product into carrier on the lid, starting with the bottom tier, to prevent damaged product.
7. Lower and lock the lid down and press the appropriate product button (2, 4, 6, or 8 head).
8. At the end of the cycle, pressure begins venting automatically, alarm sounds, and the display shows “DONE”. At this time, press the appropriate product button (2, 4, 6, or 8 head).
9. Wait for the pressure gauge to show “0” pressure in the frypot before attempting to open the lid.



**DO NOT LIFT HANDLE OR FORCE LID LATCH OPEN BEFORE PRESSURE GAUGE READS “0” PSI. ESCAPING STEAM AND SHORTENING WILL RESULT IN SEVERE BURNS.**

10. Unlock and raise the lid cautiously.
11. Using the rack handles, remove the racks of product from the carrier, starting with the top rack.



**FOLLOW THE INSTRUCTIONS BELOW TO AVOID SHORTENING OVERFLOWING THE FRYPOT, WHICH COULD RESULT IN SERIOUS BURNS, PERSONAL INJURY, FIRE, AND/OR PROPERTY DAMAGE.**

1. To protect the shortening when the fryer is not in immediate use, the fryer should be put into the Cool Mode.
2. Frying breaded products requires filtering to keep the shortening clean. The shortening should be filtered at least twice a day: after lunch rush and at the end of the day.
3. Maintain the shortening at the proper cooking level. Add fresh shortening as needed.
4. Do not overload the racks with product (22 lbs. (9.9 kgs.) maximum), or place product with extreme moisture content into racks.



**WITH PROLONGED USE, THE FLASHPOINT OF SHORTENING IS REDUCED. DISCARD SHORTENING IF IT SHOWS SIGNS OF EXCESSIVE SMOKING OR FOAMING. SERIOUS BURNS, PERSONAL INJURY, FIRE, AND/OR PROPERTY DAMAGE COULD RESULT.**

### **3-8. FILTERING INSTRUCTIONS**

The Henny Penny electric 8 head pressure fryer, Model 590, should be cleaned and the shortening filtered and polished at least twice daily; after lunch rush and at the end of the day. Refer to KFC's Standards Library.

Filter shortening immediately following a Cook Cycle when the shortening temperature is in the Cool Mode.



*Drain the shortening at 250° F (121° C) or less. Higher temperatures cause cracklings to burn on the steel frypot surfaces after the shortening has drained.*

**3-8. FILTERING**  
**INSTRUCTIONS**  
**(continued)**



**ONLY FILTER WHEN “COOL” IS DISPLAYED. FAILURE TO DO SO CAN RESULT IN SHORTENING OVERFLOWING THE FRYPOT, CAUSING SERIOUS BURNS, PERSONAL INJURY, FIRE, AND/OR PROPERTY DAMAGE.**

High volume cooking could cause the cold zone to fill quicker with cracklings and cleaning may be required more often. Part of the filtering process involves removing cracklings from the cold zone of the frypot.

1. Turn POWER/PUMP switch to OFF position.
2. Make sure filter drain pan is under fryer and the filter union is fastened to the filter standpipe, coming out of the pan.



**The filter drain pan must be as far back under fryer as it will go, and the cover in place. Be sure the hole in the cover lines up with the drain before opening the drain. Failure to follow these instructions causes splashing of shortening and could result in personal injury.**

**Surfaces of fryer and racks will be hot. Use care when filtering to avoid getting burned.**

Shortening Stirrer

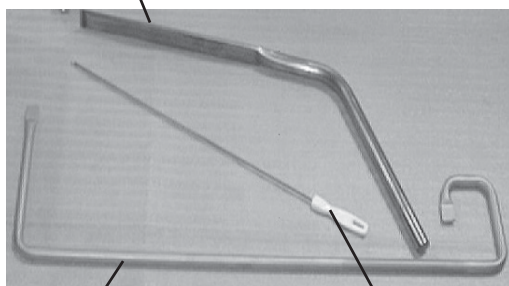

Drain Cleanout Rod

Small White Brush

3. Remove cooking racks, carrier and wipe bottom of lid. Tilt lid out of the way to clean frypot.
4. Pull drain handle towards you to open drain valve. The handle should point straight out to the front of the fryer. Use large white brush to clean cracklings from the elements and from sides and bottom of frypot as shortening drains. Use the drain cleanout rod to push cracklings through drain opening in bottom of frypot if necessary. Using the small straight white brush, clean between the elements and the frypot wall.



**BRUSH ALL CRACKLINGS FROM FRYPOT SURFACES AND THE COLD ZONE DURING THE FILTERING PROCESS. FAILURE TO DO SO CAN RESULT IN SHORTENING OVERFLOWING THE FRYPOT, WHICH COULD CAUSE SERIOUS BURNS, PERSONAL INJURY, FIRE AND/OR PROPERTY DAMAGE.**



### **3-8. FILTERING** **INSTRUCTIONS** **(Continued)**

5. Scrape cracklings and crackling ring from frypot and discard. Do not let cracklings drain into filter drain pan. These cracklings can cause a burned taste in gravy. Wipe all surfaces with a clean damp towel. If water drops into cold zone, dry with towel before pumping shortening back into the frypot.

#### **CAUTION**

*Do not bang the pot scraper, or other cleaning utensil, on the frypot rim. Damage to the frypot rim could result and the lid may not seal properly during a cook cycle.*

6. Return drain handle to the closed position to close the drain.
7. Turn POWER/PUMP switch to PUMP, and when all shortening has been pumped into frypot swing drain handle to the closed position to close the drain.



**IF THERE ARE AIR BUBBLES COMING UP IN THE SHORTENING, IT'S POSSIBLE THAT THE FILTER CONNECTION AT THE UNION ON THE FILTER TUBE IS NOT TIGHTENED PROPERLY. IF SO, TURN OFF THE PUMP AND USE PROTECTIVE CLOTH OR GLOVE WHEN TIGHTENING THE UNION. THIS UNION WILL BE HOT AND SEVERE BURNS WILL RESULT.**

### **3-9. CHANGING THE FILTER** **ENVELOPE**

The filter envelope should be changed after 10-12 filterings, or whenever it becomes clogged with crumbs. Refer to KFC's Standards Library.



**Use protective cloth or glove when disconnecting the filter union or severe burns could result.**

**If the filter pan is moved while full of shortening, use care to prevent splashing, or severe burns could result.**

#### **NOTICE**

Be sure that the filter screens, crumb catcher, filter clips and the standpipe are thoroughly dry before assembly of the filter envelope or water will dissolve the filter paper.

### **3-10. CLEANING THE FRYPOT**

After the initial installation of the fryer, as well as before every change of shortening, the frypot should be thoroughly cleaned as follows:

1. Turn the POWER/PUMP switch to OFF position, and unplug unit from wall receptacle.



**Moving the fryer or filter drain pan while containing hot shortening is not recommended. Hot shortening can splash out and severe burns could result.**

**The filter drain pan must be as far back under fryer as it will go, and the cover in place. Be sure the hole in the cover lines up with the drain before opening the drain. Failure to follow these instructions causes splashing of shortening and could result in personal injury.**

2. If hot shortening is present in the frypot, it must be drained by slowly pulling the drain handle out towards you.
3. Close the drain valve and discard the shortening.
4. Raise lid, remove the racks and carrier from lid, and tilt lid back, so that the lid won't interfere with cleaning.
5. Refer to KFC's Standard's Library on cleaning instructions.



**DO NOT CLOSE LID WITH WATER AND/OR CLEANER IN FRYPOT. WATER UNDER PRESSURE BECOMES SUPERHEATED. WHEN LID IS OPENED, ESCAPING WATER AND STEAM WILL RESULT IN SEVERE BURNS.**



**If the cleaning solution in the frypot starts to foam and boil over, immediately turn the power switch to OFF and do not try to contain it by closing the fryer lid or severe burns could result.**



**3-10. CLEANING THE FRYPOT**  
**(Continued)**



*Do not use steel wool, other abrasive cleaners or cleaners/sanitizers containing chlorine, bromine, iodine or ammonia chemicals, as these will deteriorate the stainless steel material and shorten the life of the unit.*

*Do not use a water jet (pressure sprayer) to clean the unit, or component damage could result.*



Make sure the inside of the frypot, the drain valve opening, and all parts that come in contact with the new shortening are as dry as possible.

**3-11. FILTER PUMP MOTOR PROTECTOR-MANUAL RESET**

The filter pump motor is equipped with a manual reset button, located on the rear of the motor, in case the motor overheats. If motor won't run, wait about 5 minutes before attempting to reset this protective device to allow motor to cool. Remove the access panel on the left side panel of the unit to reset the button. It takes some effort to reset, and a screwdriver can be used to help reset the button.



**To prevent burns caused by splashing shortening, turn the unit's main power switch to the OFF position before resetting the filter pump motor's manual reset protection device.**

**3-12. REGULAR MAINTENANCE SCHEDULE**

As in all food service equipment, the Henny Penny pressure fryer does require care and proper maintenance. The table below provides a summary of scheduled maintenance. The following paragraphs provide preventive maintenance procedures to be performed by the operator.

<b>Procedure</b>	<b>Frequency</b>
Filtering of shortening	See KFC's Standards Library
Changing of shortening	See KFC's Standards Library
Changing the filter envelope	See KFC's Standards Library
Cleaning the deadweight assy.	Daily-see Preventive Maintenance Section
Cleaning the frypot	See KFC's Standards Library
Cleaning the Nylatrons	Monthly-see Preventive Maintenance Section
Reversing lid gasket	Every 90 Days-see Preventive Maintenance Section
Lubricate rear lid rollers	Annually-see Preventive Maintenance Section
Cleaning safety relief valve	Annually-see Preventive Maintenance Section
Inspect Counter-Weight Cables	Annually-see Preventive Maintenance Section

### Cleaning Deadweight Assembly - Daily



**DO NOT ATTEMPT TO REMOVE DEADWEIGHT CAP WHILE FRYER IS OPERATING. SEVERE BURNS OR OTHER INJURIES WILL RESULT.**

1. At the end of each day's usage of the fryer, the deadweight assembly must be cleaned. The fryer must be off and the pressure released. Open the lid and then remove the deadweight valve cap and deadweight.



**Deadweight cap may be hot. Use protective cloth or glove, or burns could result.**

**Failure to clean the deadweight assembly daily could result in the fryer building too much pressure. Severe injuries and burns could result.**

2. Wipe both the cap and deadweight with a soft cloth. Make certain to thoroughly clean inside cap, the deadweight seat, and around deadweight orifice.
3. Clean the exhaust tube with stainless steel brush (Henny Penny part number 12147).
4. Dry parts and replace right away to prevent damage or loss.

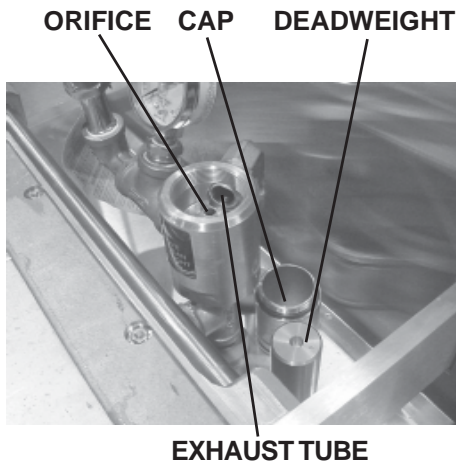

### Cleaning Nylatrons - Monthly

1. Spray Henny Penny biodegradable, food safe, foaming degreaser (part no. 12226) on Nylatrons.
2. Raise lid up and down several times to spread the degreaser.
3. Wipe Nylatrons to remove food soil, grease, and degreaser residue.



### Reversing Lid Gasket - Every 90 Days

Reversing the lid gasket helps to prevent early failure of lid gasket and the loss of pressure during a cook cycle.

1. Raise the lid and remove racks and carrier.
2. Grasping the lid handle, lift the front of the lid up until it stops in an upright position.

**HENNY PENNY**  
Engineered to Last™  
**3-13. PREVENTIVE  
MAINTENANCE  
(Continued)**

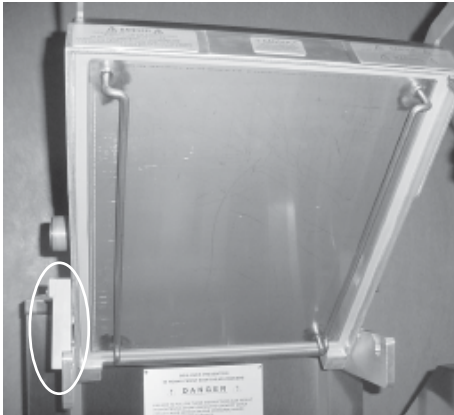

### Reversing Lid Gasket (Continued)



**Be sure the metal arm on the left side of the lid is in the vertical position holding the lid upright, or severe injuries could result. (See photo at left.)**

- Using a thin blade screwdriver, pry out the gasket at the corners. Remove the gasket.

### NOTICE

Check the gasket for any tears or nicks. If the gasket is damaged, it needs to be replaced.

- Clean the gasket and gasket seat with hot water.
- Rotate the gasket with the opposite side facing out.

### NOTICE

Install the 4 corners of the lid gasket. Smooth the gasket into place, working from the corners towards the middle of each side.

### Lubricating Lid Rollers - Annually

The lid rollers, in the back of the fryer, should be lubricated at least once a year, to allow the lid easy movement.

- Remove the back shroud of the fryer.
- Using spindle lube, part number 12124, place a small amount of lube on both top and bottom rollers. Make sure to lube both left and right rollers.

**HENNY PENNY**  
 Engineered to Last™  
**3-13. PREVENTIVE  
 MAINTENANCE  
 (Continued)**

SAFETY VALVE



### Cleaning Safety Relief Valve-Annually



**DO NOT ATTEMPT TO REMOVE SAFETY VALVE WHILE FRYER IS OPERATING, OR SEVERE BURNS OR OTHER INJURIES WILL RESULT.**

**DO NOT DISASSEMBLE OR MODIFY THIS SAFETY VALVE. TAMPERING WITH THIS VALVE COULD CAUSE SERIOUS INJURIES AND WILL VOID AGENCY APPROVALS AND APPLIANCE WARRANTY.**

1. Use a wrench to remove pressure gauge.
2. Use a wrench to loosen the valve from the pipe tee, turn counterclockwise to remove.
3. Clean the inside of the pipe tee with hot water.

### NOTICE

Turn the safety relief valve towards the rear of the fryer when reinstalling the relief valve.

4. Immerse the safety relief valve in a soapy water solution for 24 hours. Use a 1:1 dilution rate. The valve cannot be disassembled. It is factory preset to open at 14-1/2 pounds of pressure. If it does not open or close, it must be replaced.

### 3-13. PREVENTIVE MAINTENANCE Continued

#### Inspect Counter-weight Cables-Annually

Henny Penny 8 head fryers use two cables in the counter-weight mechanism that helps in the raising and lowering of the lid. Cables should be visually inspected yearly, either as part of a planned maintenance program or during a routine service call. Cables more than 10 years old should be replaced regardless of inspection results.

### NOTICE

If lid becomes difficult to operate, stop using the fryer and call for service. Cables need replaced.



**Figure 1**

1. Using a 3/8" socket, remove the 6 keps nuts around exterior of rear cover, shown in Figure 1.
2. Lift up on the rear cover and pull out at the bottom to clear threaded studs. Figure 2. (Removing top shroud makes it easier to remove the rear cover, but is not necessary.)



**Figure 2**



View of the counter-weights  
with cover removed

**3-14. PREVENTIVE  
MAINTENANCE  
(Continued)**

**Inspect Counter-weight Cable-Annually (continued)**

3. Inspect the counter-weight cables. If cables have cracks in the jacket, missing pieces in the jacket, or other obvious signs of wear, call for service to have both cables replaced.

**NOT OK - REPLACE**

**Cracks in jacket and obvious signs of wear.**

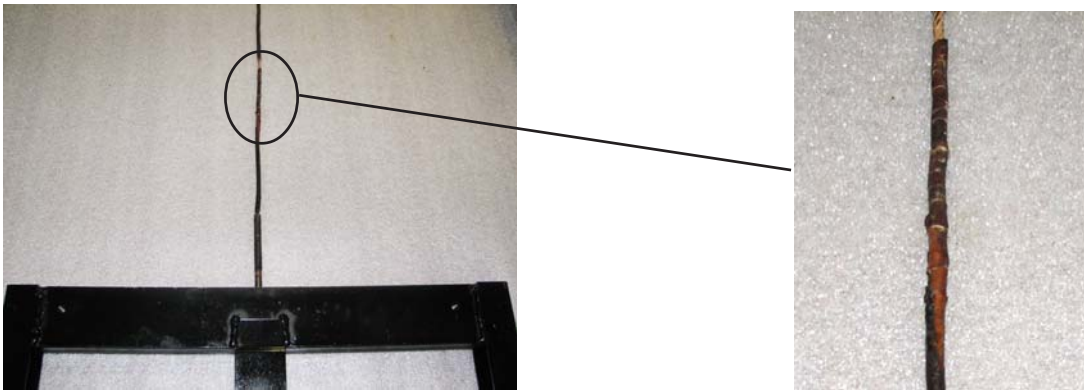

**OK**

**No signs of cracking or wear.**

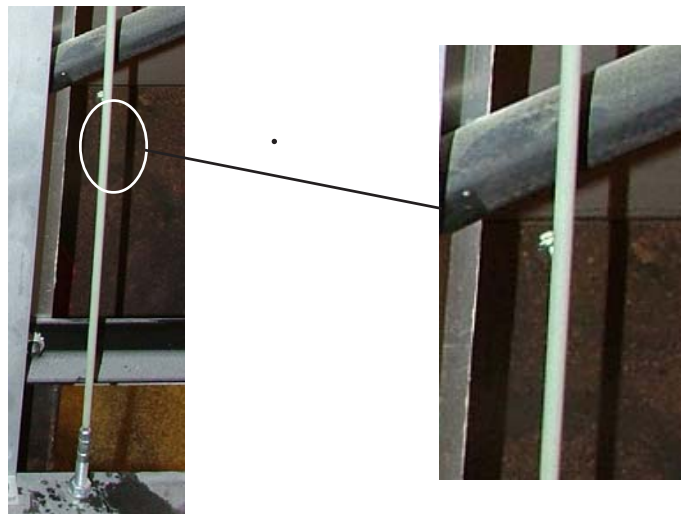

1. Press and hold the FUNCTION button for two seconds. “REG PROGRAM” shows in the display, followed by “CODE”.
2. Press the code 1,2,3. “SELECT PRODUCT” scrolls across the display.

## NOTICE

If no buttons are pressed, within approximately 1 minute while in the Program Mode, the controls will revert back to the Cook Mode.

3. Press the appropriate product button, (1-0), to identify what product you want to program.
4. “INT1” and “TIME” flashes on the left side of the display. The right side shows the starting time of the Cook Cycle and can be changed by pressing the appropriate numbers. Ex: Press 1,0,0,0 and 10:00 flashes on the right side of the display, setting the start time at 10 minutes.
5. After the time is set, press and release the FUNCTION button and “INT1” and “TEMP” flashes on the left side of the display. The right side shows the starting temperature and can be changed by pressing the appropriate numbers. Ex: Press 2,5,0 and “250° F” will show on the right side of the display, setting the start temperature at 250° Fahrenheit.
6. After the temperature is set, press and release the FUNCTION button and “INT1” and “PRESS” flashes on the left side of the display. Press any of the product buttons, (1-0), to turn the pressure on or off.
7. After the pressure is set, press and release the FUNCTION button and “INT1”, “LOAD”, and “COMP” flashes on the left side of the display. The factory preset load compensation value shows in the right side of the display.



### **3-14. PROGRAMMING** **(Continued)**

8. After the load compensation, press and release the FUNCTION button. “PROP” and “CONTROL” shows on the left side of the display and the factory preset proportional control temperature shows on the right side of the display.
9. After the proportional control, press and release the FUNCTION button. “ALM 1” and “TIME” flashes in the left side of the display, and the first alarm time shows on the right side of the display. To change the time the alarm sounds, press the appropriate product buttons to set the time. Ex: Press 1,0,0,0. 10:00 flashes on the right side of the display, which means when the timer counts down to 10 minutes, an alarm will sound.
10. After alarm is set, press and release the FUNCTION button. “ALM 1”, “SELF-”, and “CANCEL” flashes in the left side of the display and “YES” or “NO” shows on the right side of the display. The yes and no can be toggled by pressing any of the product buttons, (1-0). “YES” means the alarm tone automatically stops after several beeps. “NO” means someone must manually press the appropriate product button to stop the alarm tone.
11. Repeat steps 9 and 10 for alarms 2 and 3.
12. After alarm 3 is set, press and release the FUNCTION button. “FILTER” and “CYCLES” shows on the left side of the display and the filter cycle value is on the right side of the display. The value is the number of Cook Cycles that must completed before the control signals the operator that the shortening needs filtered



### **3-14. PROGRAMMING** **(Continued)**

13. After the filter value is set, press and release the FUNCTION button. “EOC” and “EXIT” flashes on the left side of the display, and “COOL” shows on the right side of the display. The end-of-cycle (EOC), exit point can be set to COOL, SETP, or FLTR, by pressing any of the product buttons (EOC). At the end of a Cook Cycle, the controls can be set to return to: COOL, the setpoint temperature, or to signal the operator to filter the shortening.
14. After the end-of-cycle setpoint is set, press and release the FUNCTION button. “HEAD” and “COUNT” flashes on the left side of the display and a number shows on the right side of the display. The number on the right, is the number of head of chicken to be cooked when that product button is pressed. The number can be changed by pressing the appropriate product button.

### **NOTICE**

Another product can be programmed while in the Program Mode by following these procedures:

Press and hold the SCAN button at any time while in the Program Mode, and the display scrolls “SELECT PRODUCT”. Then press any of the product buttons, (1-0), and now that product can be programmed.

15. To program second interval, press and release the SCAN button while in the Time Mode, of the first mode. “INT2” and “TIME” flashes on the left side of the display. Then follow the steps above, starting with step 4.

### **3-15. SPECIAL PROGRAM MODE**

#### **Review Usage**

1. Press and hold the FUNCTION button for two seconds until “REG PROGRAM” shows in the display. As soon as “REG PROGRAM” shows in the display, press and release the FUNCTION button 1 time until “REVIEW USE” shows in the display.
2. “DAILY” shows in the display. Press any of the product buttons to view the usage of that product. Press and hold the FUNCTION button to exit Special Program Mode.



### **3-15. SPECIAL PROGRAM MODE (Continued)**

- Reset Usage**
1. Press and hold the FUNCTION button for two seconds until “REG PROGRAM” shows in the display. As soon as “REG PROGRAM” shows in the display, press and release the FUNCTION button 2 times until “RESET USE” shows in display.
  2. When “CODE” shows in the display, press 1-3-5. “DAILY” will show in the display, and press any of the product buttons to reset them to 0.

### **Factory Presets (F/C, Gas/Electric, Speaker Volume, Speaker Frequency, Codes, Initialize System)**

1. Press and hold the FUNCTION button for two seconds until “REG PROGRAM” shows in the display. As soon as “REG PROGRAM” shows in the display, press and release the FUNCTION button 3 times until “FAC PRESET” shows in the display.
2. When “CODE” shows on the display, enter 2-9-5-7. “DEG” and “MODE” flashes in the display. Press any of the product buttons to toggle from °F to °C, and vice versa.
3. Press and release the FUNCTION button and “TYPE” and “FRYR” flashes in the display. Press any of the product buttons to toggle from “GAS” to “ELEC”, or vice versa.
4. Press and release the FUNCTION button twice, and “SPKR” and “VOL” flashes in the display. The volume can be changed from 01 to 10, 10 being the loudest.
5. Press and release the FUNCTION button 3 times, and “SPKR” and “FREQ” flashes in the display. The frequency can be set from 100 to 2000.
6. Press and release the FUNCTION button 10 times, and “INITIALIZE SYSTEM” scrolls across the display. Press and hold any of the product buttons and the display counts down from 5. Once the display counts down, release the product button, and the control sets factory preset parameters into the controls.

## NOTICE

Before attempting to change the other modes in the Factory Preset Mode, please call the Henny Penny Technical Service Department at 1-800-417-8405, or 1-937-456-8405.



**3-15. SPECIAL PROGRAM MODE**  
**(Continued)**

**Tech I/O Mode**

1. Press and hold the FUNCTION button for two seconds until “REG PROGRAM” shows in the display. As soon as “REG PROGRAM” shows in the display, press and release the FUNCTION button 4 times until “TECH I-O” shows in the display.
2. When “CODE” shows in the display, press 2-4-6 (1-7-7-6 for CE units). “HEAT”, “PRESSURE”, and “PUMP” shows alternately in the display. Also, the LEDs over 1, 2 and 3 flashes alternately.
3. To test the heat circuit, press and hold the 1 button.
4. To test the pressure system, press and hold the 2 button.
5. To test the pump system, press and hold the 3 button.



**3-15. SPECIAL PROGRAM  
MODE (Continued)**

**Heat Control**

1. Press and hold the FUNCTION button for two seconds until “REG PROGRAM” shows in the display. As soon as “REG PROGRAM” shows in the display, press and release the FUNCTION button 6 times until “HEAT CNTRL” shows in the display.
2. When “CODE” shows in the display, press 1-2-3-4. “MELT”, “EXIT”, and “TEMP” flashes in the display, along with the shortening temperature at which the unit exits the Melt Cycle. This should be set at 180° F (82° C), and should not be changed until the factory is consulted.
3. Press and release the FUNCTION button and ”MELT”, “CYCLE”, and “100s” shows alternately in the display, along with the period (pulse) length of 4000. This should not be changed until the factory is consulted.
4. Press and release the FUNCTION button twice and “MELT”, “ON-”, “TIME”, and “100s”, shows alternately in the display, along with the length of time the heat is on. This should be set at 1700, and should not be changed until the factory is consulted.
5. Press and release the FUNCTION button three times and “COOL”, “SET-”, and “POINT” shows alternately in the display, along with the temperature at which the control exits the Melt Cycle. This is set at 250° F (121° C), and should not be changed until the factory is consulted.
6. Press and release the FUNCTION button four times and “AUTO”, and “IDLE” shows alternately in the display, along with “OFF”. This should not be changed until the factory is consulted.
7. Press and release the FUNCITON button five times and “AUTO”, “IDLE”, and “MMSS” shows alternately in the display, along with “0:00”. This should not be changed until the factory is consulted.
8. The last 3 functions in the Heat Control Mode are used by the factory only, and should not be changed.

## SECTION 4. TROUBLESHOOTING

### 4-1. TROUBLE SHOOTING GUIDE

Problem	Cause	Correction
Power switch on but fryer completely inoperative	<ul style="list-style-type: none"> <li>• Open circuit</li> </ul>	<ul style="list-style-type: none"> <li>• Fryer plugged in</li> <li>• Check breaker or fuse at wall</li> </ul>
Pressure not exhausting at end of Cook Cycle	<ul style="list-style-type: none"> <li>• Solenoid or exhaust line clogged</li> </ul>	<ul style="list-style-type: none"> <li>• Turn off and allow fryer to cool to release the pressure in frypot; have all lines, solenoid and exhaust tank cleaned</li> </ul>
Operating pressure too high	<ul style="list-style-type: none"> <li>• Deadweight clogged</li> </ul>	<ul style="list-style-type: none"> <li>• Turn off and allow fryer to cool to release the pressure in frypot; clean deadweight; see Preventive Maintenance Section</li> </ul>



**DO NOT OPERATE UNIT IF PRESSURE GAUGE SHOWS HIGH PRESSURE CONDITIONS. SEVERE INJURIES AND BURNS WILL RESULT. IMMEDIATELY PLACE THE POWER/PUMP SWITCH IN THE OFF POSITION, WHICH RELEASES THE PRESSURE BY ALLOWING THE UNIT TO COOL. DO NOT RESUME USE OF UNIT UNTIL CAUSE OF HIGH PRESSURE HAS BEEN FOUND AND CORRECTED.**

Pressure does not build	<ul style="list-style-type: none"> <li>• Not enough product in frypot</li> <li>• Metal shipping spacer not removed from deadweight assy.</li> <li>• Pressure not programmed</li> <li>• Lid gasket leaking</li> </ul>	<ul style="list-style-type: none"> <li>• Place full capacity product in frypot when using fresh shortening.</li> <li>• Remove shipping spacer; see Unpacking Instructions Section</li> <li>• Check programming</li> <li>• Reverse or replace lid gasket</li> </ul>
Shortening not heating	<ul style="list-style-type: none"> <li>• Drain valve open</li> <li>• High temperature limit tripped</li> </ul>	<ul style="list-style-type: none"> <li>• Close drain valve.</li> <li>• Reset high temperature limit; see Operating Components Section</li> </ul>
Foaming or boiling over	<ul style="list-style-type: none"> <li>• See Boil-Over chart on fryer and beginning of Operation Section in this manual</li> </ul>	<ul style="list-style-type: none"> <li>• Follow Boil-Over procedures from chart</li> </ul>
Shortening not draining	<ul style="list-style-type: none"> <li>• Drain valve clogged</li> </ul>	<ul style="list-style-type: none"> <li>• Push cleaning rod through open drain valve</li> </ul>
Filter motor won't run	<ul style="list-style-type: none"> <li>• Motor overheated</li> </ul>	<ul style="list-style-type: none"> <li>• Reset motor; see Filter Pump Motor Protector-Manual Reset Section</li> </ul>

## NOTICE

More detailed troubleshooting information is available in the Technical Manual, available at [www.hennypenny.com](http://www.hennypenny.com), or 1-800-417-8405 or 1-937-456-8405.

In the event of a control system failure, the digital display will show an “Error Message”. These messages are coded: “E04”, “E05”, “E06”, “E41”. A constant tone is heard when an error code is displayed, and to silence this tone, press any of the product buttons.

<b>DISPLAY</b>	<b>CAUSE</b>	<b>PANEL BOARD CORRECTION</b>
“E04”	Control board overheating	Turn switch to OFF position, then turn switch back to ON; if display still shows “E04”, the board is getting too hot; check for signs of overheating behind the control panel; once panel cools down the controls should return to normal; if “E04” persists, replace the control
“E05”	Shortening overheating	Turn switch to OFF position, then back to ON; if display shows “E05”, the heating circuits and temperature probe should be checked; once the unit cools down, the controls should return to normal; if “E05” persists, replace the controls
“E06”	Temperature probe failure	Turn switch to OFF position, then back to ON; if the display shows “E06”, the temperature probe should be checked; once the temperature probe is repaired, or replaced, the controls should return to normal; if “E06” persists, replace the controls
“E41”	Programming Failure	Turn switch to OFF position, then back to ON. If display shows “E41”, the control should be re-initialized (see programming section); if the error code persists, replace the control panel.
“E71”	Pump motor relay failure or wiring problem	Replace relay if contacts are stuck closed; check wiring on POWER/PUMP switch, or at wall receptacle; L1 and N may be reversed





## GLOSSARY

### HENNY PENNY PRESSURE FRYERS

air valve	a valve that allows air into the filter lines when the pump is on in the mixing mode on eight head fryers
airflow switch	a switch that senses the amount of airflow coming from the blower; if the airflow falls below a certain level, the switch cuts power to the gas control valve that shuts down the burners on gas eight head fryers
blower	located on the rear of a gas eight head fryer, the blower pulls flue gases out of the flue and provides the proper amount of air to the burner tubes for efficient combustion
breeding	a flour and seasoning mixture used to coat the product prior to frying
burner assembly <i>(gas fryers only)</i>	an assembly on gas fryers that houses the pilot light which ignites the gas that heats the fryer
burner chamber <i>(gas fryers only)</i>	the area on four head fryers in which the gas combustion that heats the shortening takes place
burner tubes <i>(gas fryers only)</i>	the tubes in eight head fryers through which heated air is forced to heat the shortening
carrier cook cycle	a wire frame inside the eight head frypot that holds five racks of product during the
casters	the wheels on bottom of the fryer that allow the unit to roll; casters should be locked when unit is in use and not being moved; casters may be adjusted to help level the fryer
cleaning solution	an agent used to clean the frypot; see recommended cleaning procedures
cold zone	an area in the bottom of the frypot where shortening is cooler than the area above; the zone allows the crumbs to settle without burning
condensation drain pan	a pan located at the bottom of the fryer that collects condensation from the steam exhaust system; the pan should be removed and emptied periodically
cook cycle	a programmed cycle that cooks a particular product at a preselected temperature and for a preselected time
cooking load	the amount of product cooked during a cook cycle
cool	a preset temperature, usually 250° F (121° C) or less, which can be manually or automatically switched to, to save the life of the shortening, when not cooking.
counterweight	the weights shipped with the fryer that, when installed in the counterweight assembly, enable the eight head fryer lid to lift easily



	an assembly of weights and cables that enable the eight head fryer lid to lift easily
cracklings	the crumbs of breading that come off the product during a cook cycle
crumb catcher	the part of the filter assembly on four head fryers that filters crumbs out of the shortening before the shortening is pumped back into the frypot
data plate	a label or plate located on the right side panel of the fryer that indicates the fryer type, serial number, warranty date, and other information
deadweight	a metal cylinder that works with the orifice to regulate the amount of steam entering the deadweight assembly
deadweight valve assembly	an assembly that controls pressure inside the frypot; the entire deadweight assembly should be cleaned according to the recommended procedures; the assembly is made up of the deadweight, the deadweight cap, the deadweight orifice, the deadweight valve, and the deadweight body
deadweight cap	a threaded cap that screws onto the deadweight valve housing
deadweight orifice	an opening that regulates the amount of steam entering the deadweight assembly
deadweight body	a container that holds the deadweight assembly
deadweight seat	indentation on both ends of deadweight
dilution box	a metal air intake device on the rear of the fryer to pull in fresh air for the blower
drain interlock switch	a microswitch that automatically shuts off the fryer heat in the event the drain valve is inadvertently opened while the fryer power switch is in the ON position
drain valve	a valve that allows the shortening to drain from the frypot into the filter drain pan; the fryer power switch should be in the OFF position before the drain valve is opened; the drain valve should remain closed at all other times
drop temperature	the starting, preset cooking temperature, at which product is placed in the shortening
dumping table	a table onto which the cooked product is dumped after removal from the fryer frypot
exhaust hose	a hose used to vent steam from the frypot on eight head fryers
fill lines	the lines marked on the interior rear wall of the frypot that show the proper shortening level ( <i>also referred to as level indicator lines</i> )
filter clips	the clips are the part of the filter screen assembly that holds the filter envelope closed
filter union	the threaded connection between the fryer and the filter system that can be connected or released without tools



filter drain pan	a pan that rolls or slides under the fryer into which shortening is drained
filter envelope	a fiber envelope into which the filter screen is placed; the end of the envelope is folded and held closed with filter clips; a part of the filter screen assembly
filter quick disconnect	an optional connection on the fryers allowing the filter rinse hose to be connected or released without tools
filter screen assembly	an assembly that filters the shortening as it is pumped from the frypot; the assembly is made up of two filter screens, a filter envelope, and two filter clips <i>(Note: four head fryers have three filter screens that includes a crumb catcher)</i>
flame sensors <i>(gas fryers only)</i>	the sensors that shut off the gas supply to eight head gas fryers if the pilot lights go out or do not light
flashpoint	the temperature at which shortening ignites
frypot	the interior portion of the fryer that holds the shortening and the product while cooking
frypot collar	the top flat surface area around the fryer lid
gas control valve <i>(gas fryers only)</i>	an automatic dual controller that controls gas to both pilot lights and gas pressure to burners on fryers; if either pilot light goes out, the controller shuts off the gas to the other pilot light
gas valve knob <i>(gas fryers only)</i>	the knob that opens and closes the gas control valve
gas pressure regulator <i>(gas fryers only)</i>	a device located on the gas control valve that regulates the gas pressure; the pressure specifications are preset at the factory
heat indicator	the light that illuminates when the shortening is being heated; the light goes off when the preset shortening temperature has been achieved
heating elements	the coils located inside the frypot on electric fryers that heat the shortening
high limit	a temperature control that opens and shuts off the heat to the frypot if it senses shortening temperature in excess of 420°F (212°C) on eight head fryers and 450°F (232°C) on four head fryers
idle	a preset temperature, usually 250° F (121° C) or less, which can be manually or automatically switched to, to save the life of the shortening, when not cooking.
ignition modules	two modules that send electrical energy to the spark igniters that ignite the pilot lights on eight head gas fryers
L-shaped brush	a brush included with the fryer that is used to clean around the burner tubes and heating elements
landing table	another name for a dumping table <i>(see dumping table)</i>
level indicator lines	lines marked on the interior real wall of the frypot that show the proper shortening level <i>(also referred to as fill lines)</i>



lid assembly	an assembly comprised of lid, lid handle, lid latch, and lid gasket ( <i>Note: on four head fryers. the lid assembly includes spindles</i> )
lid gasket	the gasket around the lid that creates a seal when the lid is properly latched
lid handle	a handle that is attached to the lid and is used to lower the lid into contact with the frypot; the handle is then pulled forward and pushed down to lock the lid in place ( <i>see lid latch</i> )
lid latch	a mechanical catch on the front of the fryer lid that engages a bracket located on the front of the frypot; the latch holds the lid down while it is being locked into place
manual shutoff valve ( <i>gas fryers only</i> )	a valve located between the fryer and the wall that shuts off the flow of gas from the supply line; this is not the main shutoff valve for the store
P-H-T	the automatic control of pressure, heat, and time to produce appealing food product
pilot orifice ( <i>gas fryers only</i> )	a controlled opening for the pilot light located on the burner assembly
pilot light ( <i>gas fryers only</i> )	a small flame that remains burning even when the fryer is not in use; the flame ignites the gas when the fryer is turned on
poker brush	a brush that is included with the fryer that is used to clear the drain in the bottom of the frypot. ( <i>also referred to as straight brush</i> )
power/pump switch	a three-way switch located on the front control panel of the fryer that serves as an off/on switch and a filter switch
pressure gauge	the gauge located on the left rear corner of the frypot that shows the pressure inside the frypot
pressure pad	a piece of plastic on eight head fryers located between the lid locking arm and the lid casting that helps create the seal for the lid; only a service technician should perform maintenance or repair on the pressure pad
product	a food item cooked in the fryer
ready	the starting, preset cooking temperature, at which product is placed in the shortening
safety relief valve	a spring loaded valve that automatically releases excess pressure if the operating valve becomes obstructed; if the safety release valve activates, turn the Power/ Pump switch to "OFF" to release all pressure from the frypot
setpoint	a preset cooking temperature; the setpoint is a programmable feature
shipping spacer	a spacer located in the deadweight assembly for protection during shipment
shortening mixing system	an automatic system on eight head fryers that periodically uses the filter pump to mix the shortening in the frypot to prevent an accumulation of moisture to minimize the boiling action in the frypot

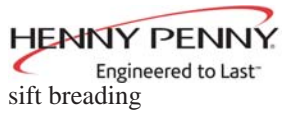

sift breading	the process of removing clumps from breading
solenoid valve	a valve used to generate or release pressure for the cook cycle
spark igniters ( <i>gas fryers only</i> )	the igniters that create a spark to ignite the pilot lights on eight head gas fryers ( <i>see ignition modules</i> )
standpipe	the pipe through which oil is pumped back into the frypot after the filtering process is complete
standpipe assembly	the pipe and fittings that are part of the shortening filtering process
straight brush	a brush that is included with the fryer that is used to clear the drain in the bottom of the frypot
temperature probe	a round probe that is located in the inside of the frypot that measures the temperature of the oil in the frypot; the probe communicates with the control panel



**Henny Penny Corporation  
P.O.Box 60  
Eaton, OH 45320**

**1-937-456-8400  
1-937-456-8402 Fax**

**Toll free in USA  
1-800-417-8417  
1-800-417-8434 Fax**

**[www.hennypenny.com](http://www.hennypenny.com)**

\* FM05 - 032 - H\* Henny Penny Corp., Eaton, Ohio 45320, Revised 7-1-13