



OPERATOR'S M A N U A L

PRESSURE FRYER (Electric)

MODEL

PFE-591



HENNY PENNY
Engineered to Last

REGISTER WARRANTY ONLINE AT WWW.HENNYPENNY.COM

HENNY PENNY

8 HEAD ELECTRIC PRESSURE FRYER

SPECIFICATIONS

Height	61" (155 cm)
Width	24" (61 cm)
Depth	41 ³ / ₄ " (107 cm)
Floor Space	Approximately 7 sq. ft. (.65 sq. m.)
Pot Capacity	8 head of chicken - 21 lbs. (9.5 kg) 100 lbs. shortening (45 Kg.)
Electrical	208 VAC, 3 Phase, 50/60 Hz, 17 KW, 47.2 Amps 240 VAC, 3 Phase, 50/60 Hz, 17 KW, 40.9 Amps 200 VAC, 3 Phase, (Delta), 50/60 Hz, 17 KW, 49.1 Amps 240 VAC, 3 Phase, (Delta), 50 Hz, 17 KW, 40.9 Amps 380 VAC, 3 Phase, 50 Hz, 17 KW, 25.8 Amps 415 VAC, 3 Phase, 50 Hz, 17 KW, 23.7 Amps
Heating	Two 8,500 watt electric immersion elements
Shipping Weight	Approximately 758 lbs. (344 kg.)

NOTICE

A data plate, located on the right side panel, gives the information of the type of fryer, serial number, warranty date, and other information pertaining to fryer. Also, the serial number is stamped on the outside of the frypot. See figure below.

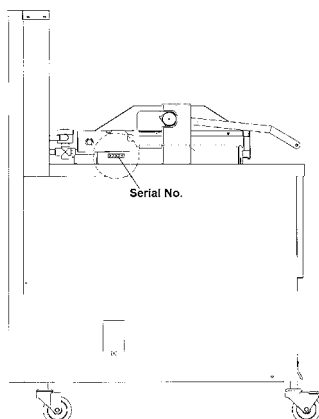

TABLE OF CONTENTS

Section		Page
Section 1.	INTRODUCTION	1-1
	1-1 Pressure Fryer	1-1
	1-2 Proper Care	1-1
	1-3 Assistance	1-1
	1-4 Safety	1-2
Section 2.	INSTALLATION	2-1
	2-1 Introduction	2-1
	2-2 Unpacking	2-1
	2-3 Selecting the Fryer Location	2-5
	2-4 Leveling the Fryer	2-5
	2-5 Ventilation of Fryer	2-6
	2-6 Electrical Requirements	2-6
	2-7 International Electrical Requirements	2-7
	2-8 Exhaust Hood Interlock Wiring	2-8
Section 3.	OPERATION	3-1
	3-1 Operating Components	3-1
	3-2 Lid Operation	3-4
	3-3 Switches and Indicators	3-6
	3-4 Clock Set	3-9
	3-5 Filling or Adding Shortening	3-11
	3-6 Product Racking Recommendations	3-12
	3-7 Basic Operation	3-13
	3-8 Care of Shortening	3-16
	3-9 Filtering Instructions	3-17
	3-10 Changing the Filter Envelope	3-20
	3-11 Filter Pump Motor Protector-Manual Reset	3-22
	3-12 Cleaning the Frypot	3-22
	3-13 Regular Maintenance	3-25
	3-14 Preventive Maintenance	3-25
	3-15 Cable Inspection	3-29
	3-16 Programming	3-31
	3-17 Special Program Mode	3-37
	3-18 Data Logging, Heat Control, Tech and Stat Modes	3-45
	3-19 Information Mode	3-46
Section 4.	TROUBLESHOOTING	4-1
	4-1 Troubleshooting Guide	4-1
	4-2 Error Code Table	4-2
	GLOSSARY	G-1

SECTION 1. INTRODUCTION

1-1. PRESSURE FRYER

The Henny Penny pressure fryer is a basic unit of food processing equipment. It has found wide application in institutional and commercial food service operations.

P-H-T

A combination of pressure, heat, and time is automatically controlled to produce the optimum in a tasty, appealing product.

Pressure

Pressure is basic to this method of food preparation. The pressure is developed from the natural moisture of the food. The patented lid traps this moisture and uses it as steam. Because the steam builds rapidly, the greater part of the natural juices are retained within the food. An operation valve vents excess steam from the pot and maintains constant live steam pressure.

Heat

Heat generated is another important factor of the pressure fryer. Energy savings is realized due to the unit's short frying time, low temperature, and heat retention of the stainless steel frypot.

Time

Time is important because the shorter time involved in frying foods results in additional economies for the user. Foods are table ready in less time than it would take to fry them in a conventional open-type fryer.



NOTICE

As of August 16, 2005, the Waste Electrical and Electronic Equipment directive went into effect for the European Union. Our products have been evaluated to the WEEE directive. We have also reviewed our products to determine if they comply with the Restriction of Hazardous Substances directive (RoHS) and have redesigned our products as needed in order to comply. To continue compliance with these directives, this unit must not be disposed as unsorted municipal waste. For proper disposal, please contact your nearest Henny Penny distributor.

1-2. PROPER CARE

As in any unit of food service equipment, the Henny Penny pressure fryer does require care and maintenance. Requirements for the maintenance and cleaning are contained in this manual and must become a regular part of the operation of the unit at all times.

1-3. ASSISTANCE

Should you require outside assistance, just call your local independent Henny Penny distributor in your area, or call Henny Penny Corp. 1-800-417-8405 toll free or 1-937-456-8405.

1-4. SAFETY

The Henny Penny pressure fryer has many safety features incorporated. However, the only way to ensure a safe operation is to fully understand the proper installation, operation, and maintenance procedures. The instructions in this manual have been prepared to aid you in learning the proper procedures. Where information is of particular importance or safety related, the words DANGER, WARNING, CAUTION, and NOTICE are used. Their usage is described below.



SAFETY ALERT SYMBOL is used with DANGER, WARNING, or CAUTION which indicates a personal injury type hazard.



NOTICE is used to highlight especially important information.



CAUTION used without the safety alert symbol indicates a potentially hazardous situation which, if not avoided, may result in property damage.



CAUTION used with the safety alert symbol indicates a potentially hazardous situation which, if not avoided, may result in minor or moderate injury.



WARNING indicates a potentially hazardous situation which, if not avoided, could result in death or serious injury.



DANGER INDICATES AN IMMINENTLY HAZARDOUS SITUATION WHICH, IF NOT AVOIDED, WILL RESULT IN DEATH OR SERIOUS INJURY.

SECTION 2. INSTALLATION

2-1. INTRODUCTION

This section provides the installation and unpacking instructions for the Henny Penny Model PFE-591.

NOTICE

Installation of this unit should be performed only by a qualified service technician.



Do not puncture the fryer with any objects such as drills or screws as electrical shock or component damage could result.

2-2. UNPACKING INSTRUCTIONS

NOTICE

Note any shipping damage in the presence of the delivery agent and signed prior to his or her departure.

1. Cut and remove the plastic bands from the main box.
2. Remove the box lid and lift the main box off the fryer.
3. Remove corner packing supports (4).
4. Cut the stretch film from around the carrier/rack box and remove it from the top of the fryer lid.
5. Cut and remove the metal bands holding the fryer to the pallet.



All counterweights must be loaded before unlatching the lid, or personal injury could result.

6. Remove the fryer from the pallet.



Take care when moving the fryer to prevent personal injury. The fryer weighs approximately 758 lbs. (344 Kg).

2-2. UNPACKING
INSTRUCTIONS
(Continued)

7. Remove the counterweights from the pallet, which are strapped to the pallet, under the fryer.



Do not drop. The counterweights weigh approximately 18 lbs. (8.1 kg.) each. Handle with care, or personal injury could result.

8. Remove rear cover.
9. Load the seven weights into the counterweight assembly. See page 2-4.
10. Replace rear cover.
11. Cut warning tags from the lid assembly. The lid may now be unlatched.
12. Remove the accessories from inside the filter drain pan.
13. Prepare the deadweight valve for operation

NOTICE

The metal packing spacer is placed inside the deadweight valve housing to protect the deadweight orifice and deadweight during shipment. Remove this packing spacer prior to installation, in order to build pressure.

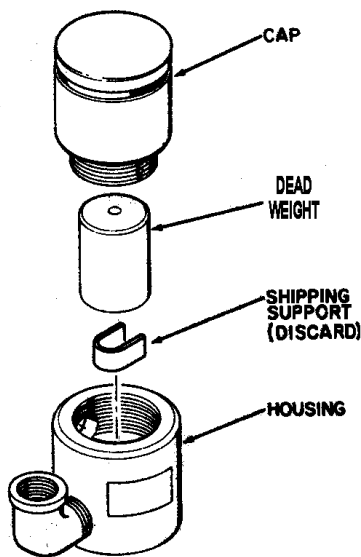

- A. Unscrew the deadweight cap.
 - B. Remove the deadweight.
 - C. Remove and discard the metal packing spacer.
 - D. Clean the deadweight orifice with a dry cloth.
 - E. Carefully place deadweight over deadweight orifice. Replace deadweight cap, finger tight.
14. Remove the protective paper from the fryer cabinet.
Clean exterior surface with a damp cloth.

Optional Ramp Unloading

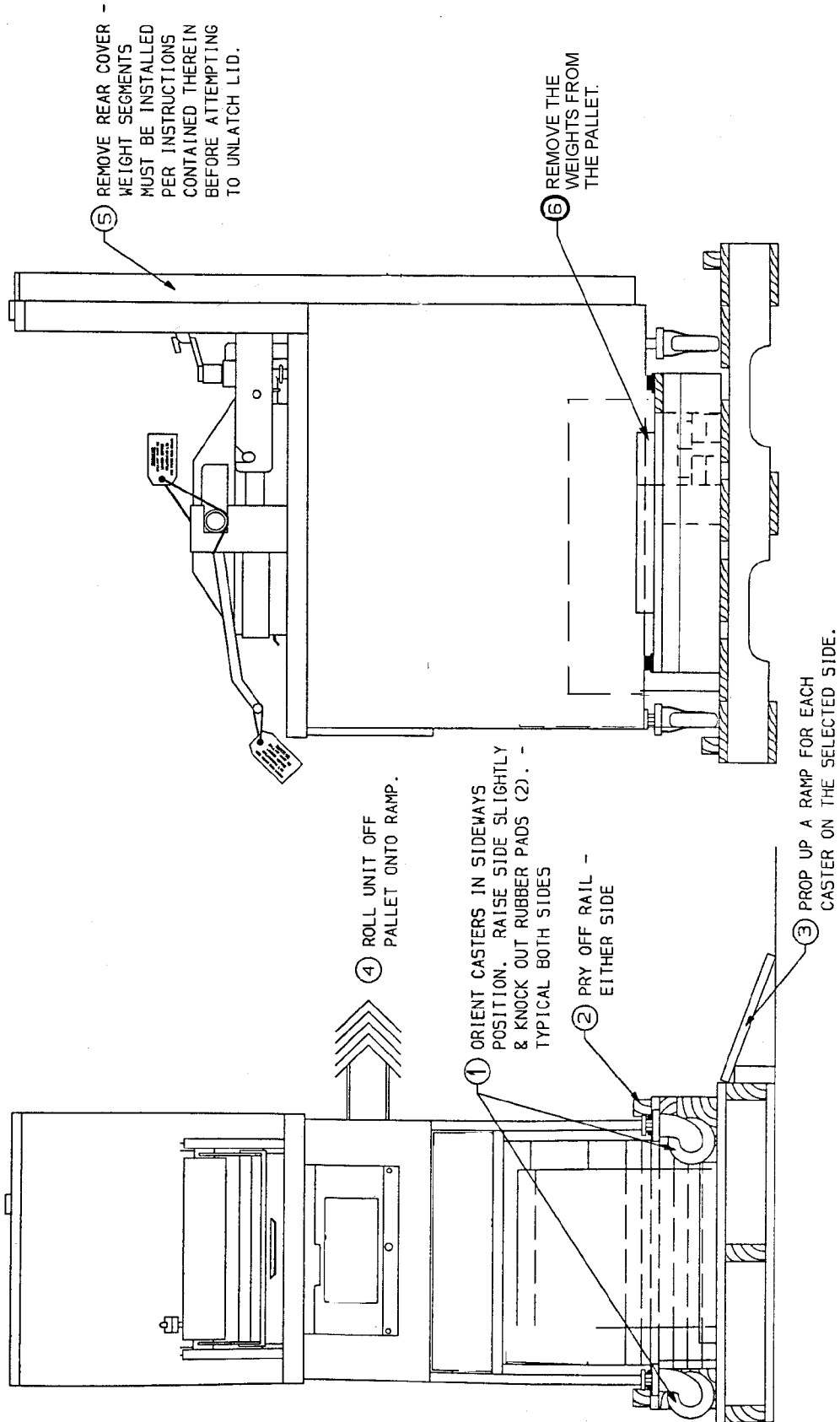

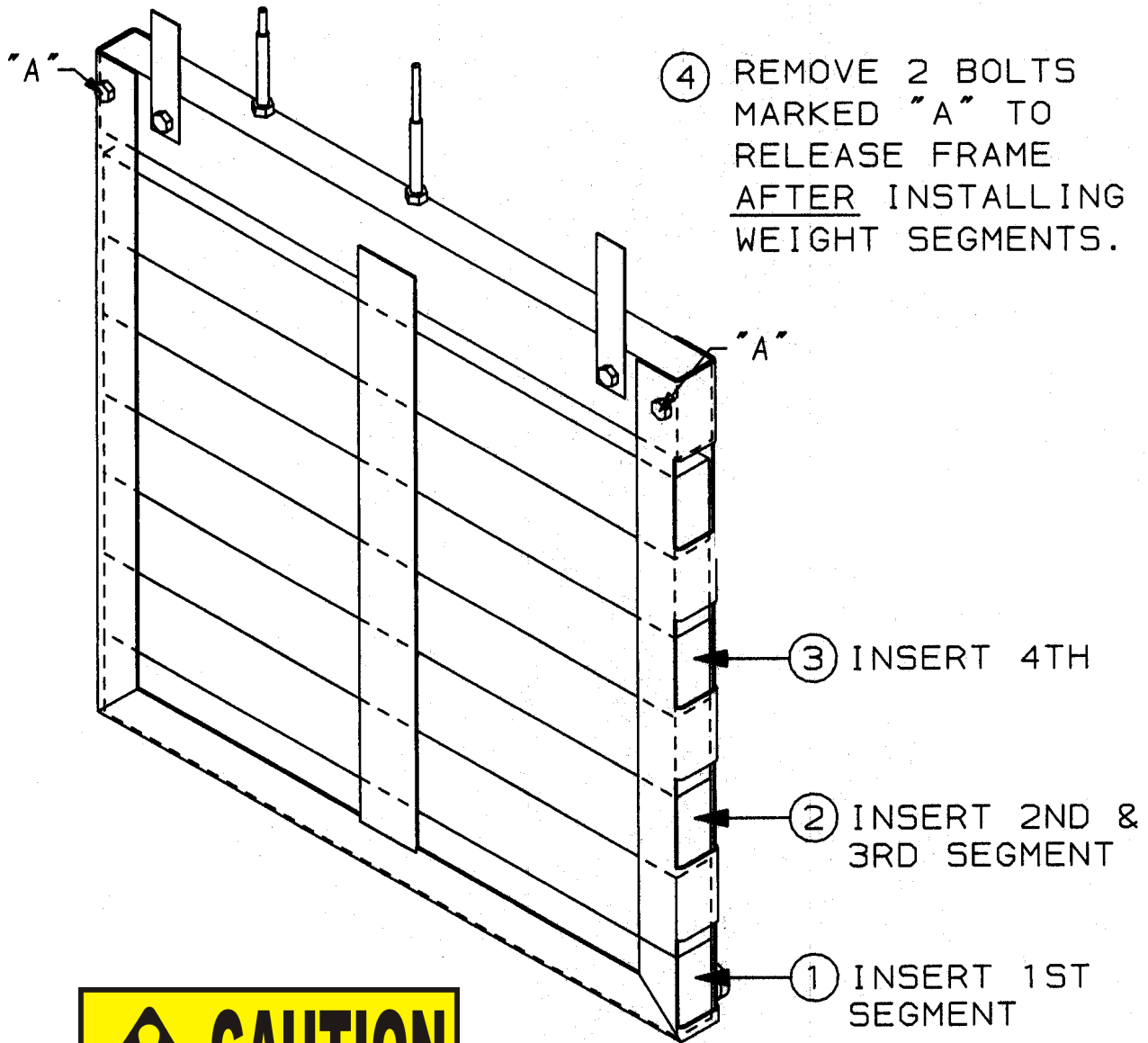

- * EACH WEIGHT SEGMENT WEIGHS APPROXIMATELY 18 LBS. (8.1 KG) - HANDLE WITH CARE.
- * ALL SEGMENTS ARE IDENTICAL.
- * ALL SEGMENTS MUST BE INSTALLED AND SECURED IN THE FRAME BEFORE ATTEMPTING TO UNLATCH LID.

**2-3. SELECTING THE FRYER
LOCATION**

The proper location of the fryer is very important for operation, speed, and convenience. Choose a location which will provide easy loading and unloading without interfering with the final assembly of food orders. Operators have found that frying from raw to finish, and holding the product in a warmer provides fast continuous service. Landing or dumping tables should be provided next to at least one side of the fryer. Keep in mind the best efficiency will be obtained by a straight line operation, i.e. raw in one side and finish out the other side. Order assembly can be moved away with only a slight loss of efficiency. To properly service the fryer, 24 inches (60.96 cm) of clearance is needed on all sides of the fryer. Access for servicing can be attained by removing a side panel.



To avoid fire and ruined supplies, the area under the fryer should not be used to store supplies.



To prevent severe burns from splashing hot shortening, position and install fryer to prevent tipping or movement. Restraining ties may be used for stabilization.

2-4. LEVELING THE FRYER

For proper operation, level the fryer from side to side and front to back, using level on the flat areas around the frypot collar.



FAILURE TO FOLLOW THESE LEVELING INSTRUCTIONS CAN RESULT IN SHORTENING OVERFLOWING THE FRYPOT WHICH COULD CAUSE SERIOUS BURNS, PERSONAL INJURY, FIRE AND/OR PROPERTY DAMAGE.

2-5. VENTILATION OF FRYER

The fryer should be located with provision for venting into adequate exhaust hood or ventilation system. This is essential to permit efficient removal of steam exhaust and frying odors. Special precaution must be taken in designing an exhaust canopy to avoid interference with the operation of the fryer. We recommend you consult a local ventilation or heating company to help in designing an adequate system.

NOTICE

Ventilation must conform to local, state, and national codes. Consult your local fire department or building authorities.

2-6. ELECTRICAL REQUIREMENTS

The electric fryer requires 208 or 240 volt, three phase, 50/60 Hertz service. The power cord may be already attached to the fryer, or provided at installation. Check the data plate mounted just above the lid, on the left side of the back shroud, to determine the correct power supply.



This fryer must be adequately and safely grounded (earthed) or electrical shock could result. Refer to local electrical codes for correct grounding (earthing) procedures or in absence of local codes, with The National Electrical Code, ANSI/NFPA No. 70-(the current edition). In Canada, all electrical connections are to be made in accordance with CSA C22.1, Canadian Electrical Code Part 1, and/or local codes.

To avoid electrical shock, this appliance must be equipped with an external circuit breaker which will disconnect all ungrounded (unearthed) conductors. The main power switch on this appliance does not disconnect all line conductors.

A separate disconnect switch with proper capacity fuses or breakers must be installed at a convenient location between the fryer and the power source. It should be an insulated copper conductor rated for 600 volts and 90° C. For runs longer than 50 feet (15.24 m) use the next larger wire size.

**2-7. INTERNATIONAL
ELECTRICAL
REQUIREMENTS**

Units being used outside the United States may not be shipped with the power cord attached to the unit because of the different wiring codes. The fryers are available from the factory wired for 208, 240, 380 and 415 volts, 3 phase, 50 Hertz service. A terminal block is mounted inside the fryer for the cable wiring. A decal on the inside of the right side panel will help in the wiring of the unit.

NOTICE

CE units require a minimum wire size of 4mm to be wired to the terminal block. If a flexible power cord is used, it must be HO7RN type.

To install the power cord, follow these procedures:

1. Remove the right side panel of the unit.
2. Install the cord, with a strain relief, to the junction box.
3. Attach the wires to the terminal block according to the wiring diagram on the side panel.
4. Pull the slack out of the cord and thread it down through the the clamp on the frame, at the rear, left leg of fryer. Then run the cable under the frame and out the rear of the fryer, so it doesn't interfere with the filter drain pan.



The filter drain pan must be as far back under fryer as it will go, and the cover in place. Be sure the hole in the cover lines up with the drain before opening the drain. Failure to follow these instructions causes splashing of shortening and could result in personal injury.

5. Wiring the fryer is now complete.

**2-8. EXHAUST HOOD
INTERLOCK WIRING**

Information for units that require wiring from the fryer to the exhaust hood.



Remove the right side panel to access the junction box and follow the appropriate wiring diagrams below.

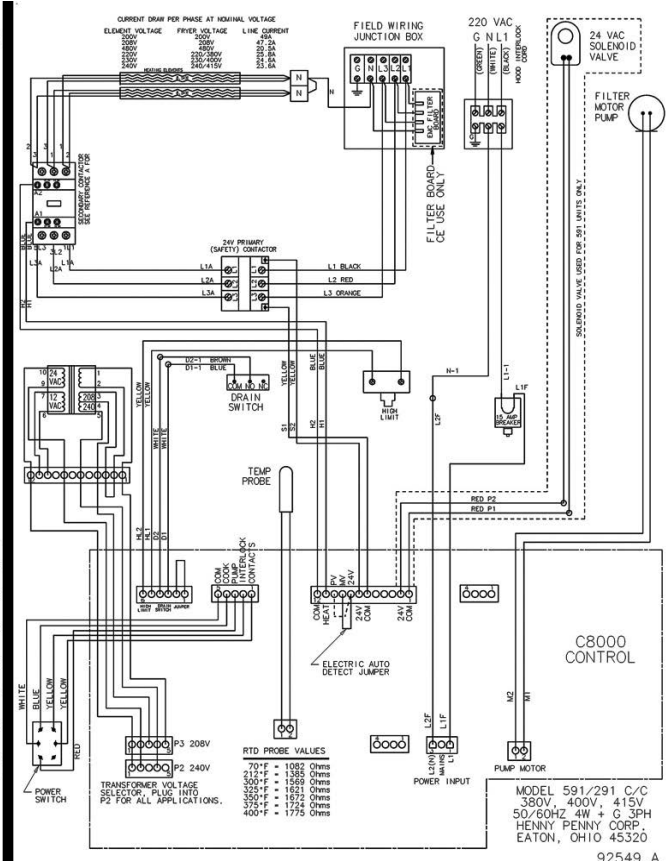
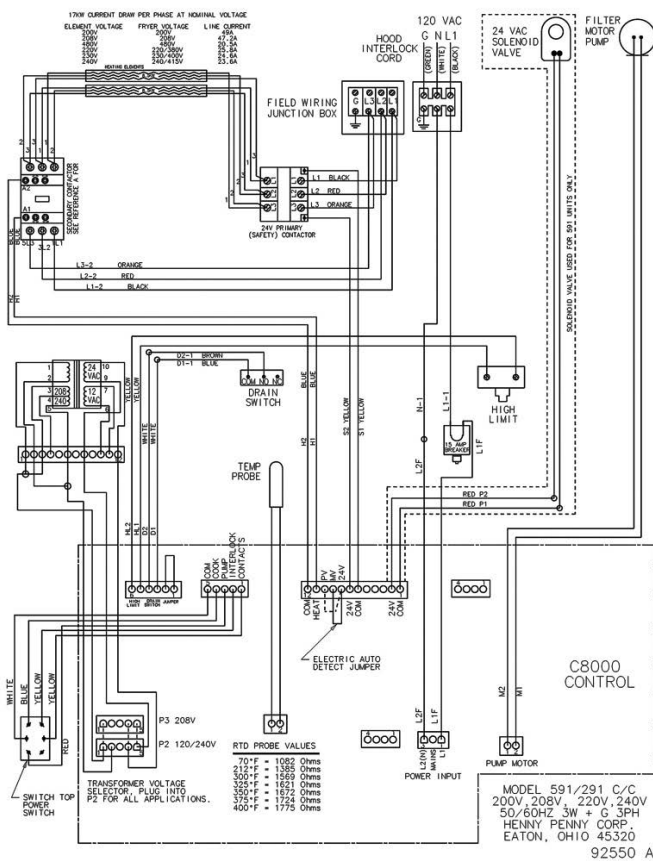

BOIL-OVER PREVENTION IN HENNY PENNY COOKERS



FAILURE TO FOLLOW THESE INSTRUCTIONS CAN RESULT IN SHORTENING OVERFLOWING THE FRYPOT WHICH COULD CAUSE SERIOUS BURNS, PERSONAL INJURY. FIRE AND/OR PROPERTY DAMAGE.

- **THE SHORTENING MAY BE STIRRED ONLY DURING THE MORNING START UP PROCEDURE. DO NOT STIR THE SHORTENING AT ANY OTHER TIME.**
- **FILTER THE SHORTENING AT LEAST TWICE A DAY.**
- **FILTER ONLY WHEN SHORTENING IS BELOW 275°F (135°C).**
- **BRUSH ALL CRACKLINGS FROM FRYPOT SURFACES AND THE COLD ZONE DURING THE FILTERING PROCESS.**
- **MAKE SURE THE FRYER IS LEVEL.**
- **BE CERTAIN THE SHORTENING IS NEVER ABOVE THE UPPER FRYPOT “FILL” LINE.**
- **BE CERTAIN THAT THE GAS CONTROL VALVE AND BURNERS ARE PROPERLY ADJUSTED. (GAS UNITS ONLY)**
- **USE RECOMMENDED LOAD SIZE**

FOR ADDITIONAL INFORMATION ON THESE INSTRUCTIONS, REFER TO THE HENNY PENNY OPERATOR MANUAL AND THE KFC STANDARDS LIBRARY.

**FOR ASSISTANCE CALL THE HENNY PENNY SERVICE DEPARTMENT AT
1-800-417-8405.
or
1-937-456-8405**

SECTION 3. OPERATION

3-1. OPERATING COMPONENTS

Frypot	This reservoir holds the cooking shortening, and is designed to accommodate the heating elements, 8 head of product and an adequate cold zone for collection of cracklings
Carrier	This stainless steel carrier consists of five racks, containing the food product during and after frying
Lid Gasket	Provides the pressure seal for the frypot chamber
Deadweight assembly	The deadweight style operating pressure relief valve is used to maintain a constant level of steam pressure within the frypot; any excess steam pressure is vented through the exhaust stack; remove the deadweight cap, and clean the cap, deadweight, and deadweight orifice once a day; see Preventive Maintenance Section



Failure to clean the deadweight assembly daily could result in the fryer building too much pressure. Severe injuries and burns could result.

Safety Relief Valve	An ASME approved spring loaded valve set at 14.5 psi (999 mbar) in the event the operation valve becomes obstructed, this safety valve will release excess pressure, keeping the frypot chamber at 14.5 psi (999 mbar); if this occurs, turn the COOK/PUMP switch to the OFF position to release all pressure from the frypot
----------------------------	-------------------------------------------------------------------------------------------------------------------------------------------------------------------------------------------------------------------------------------------------------------------------------------------------------------------------------



If safety relief valve activates, turn main power switch to the OFF position. To avoid serious burns and injuries, have fryer serviced before next use.

Safety Relief Valve Ring



DO NOT PULL THIS RING. SEVERE BURNS FROM THE STEAM WILL RESULT.

3-1. OPERATING COMPONENTS

(Continued)

Pressure Gauge

Indicates the pressure inside the frypot

Solenoid Valve

An electromechanical device that causes pressure to be held in the frypot

The valve closes at the beginning of the Cook Cycle and opens automatically at the end of the Cook Cycle; if this valve should become dirty or the teflon seat nicked, pressure will not build and it must be repaired per the Maintenance Section of the Technical Manual

Drain Valve

A two-way ball valve, normally in the closed position; turn the handle to drain the shortening from the frypot into the filter drain pan



DO NOT OPEN THE DRAIN VALVE WHILE FRYPOT IS UNDER PRESSURE. HOT SHORTENING WILL EXHAUST FROM THIS VALVE, AND SEVERE BURNS WILL RESULT.

Drain Interlock Switch

A microswitch that provides protection for the frypot in the event an operator inadvertently drains the shortening from the frypot while the main switch is in the COOK position; the switch is designed to automatically shut off the heat when the drain valve is opened

Condensation Drain Pan

The collection point for the condensation formed within the steam exhaust system; it must be removed and emptied periodically, usually daily

Shortening Mixing System

Ensures the shortening is properly mixed to prevent an accumulation of moisture, causing boiling action in the frypot; the filter pump is activated by the controls, at preset intervals, to mix the shortening

Lid Latch

A mechanical catch on the front of the lid which engages a bracket on the front of the frypot; this device holds the lid down while the lid is being locked into place, but is not meant to hold pressure in the frypot

3-1. OPERATING COMPONENTS

(Continued)

High Temperature Limit

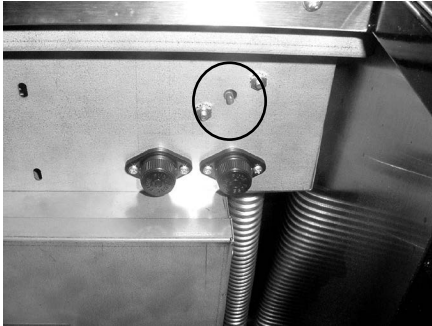

This is a safety component that senses the temperature of the shortening; if the temperature of the shortening exceeds 420°F (212°C), this control opens and shuts off the heat to the frypot; when the temperature of the shortening drops to a safe operation limit, the control must be manually reset by pressing the red reset button, located under the control panel, in the right, front of the fryer

Air Valve

Pumps air into the shortening, periodically, to keep the shortening at a uniform temperature; this only functions when the unit has been sitting idle for a period of time, and when heating up from a cold start

Filter Drain Pan

The removable pan that houses the filter and catches the shortening when it is drained from the frypot; also used to remove and discard old shortening



When hot shortening is in this pan, use extreme care to avoid burns.

Filter Union

Connects the filter to the filter pump, and allows easy removal of the filter and drain pan

Fuses

A protective device which breaks the circuit when the current exceeds the rated value

3-2. LID OPERATION

To close lid:

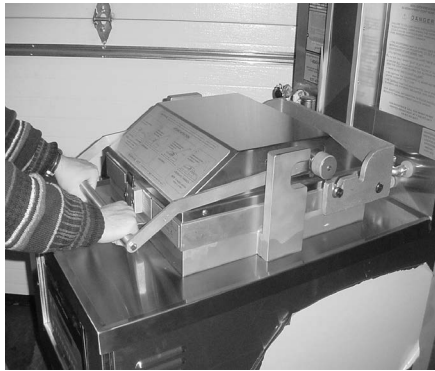

1

1. Lower the lid until lid latches into place.



2

2. Pull lid handle forward until it stops.



3

3. Lift up on the lid handle until it stops.



4

4. Bring lid handle out towards you until it stops.

5. Push lid handle down, locking lid in place.



LID MUST BE LATCHED PROPERLY, OR PRESSURIZED SHORTENING AND STEAM MAY ESCAPE FRYPOT. SEVERE BURNS WILL RESULT.

TO AVOID SERIOUS PERSONAL INJURY, DO NOT OPERATE WITHOUT LID COVER IN PLACE AND ALL COMPONENTS INSTALLED.

TO AVOID SERIOUS PERSONAL INJURY, DO NOT TAMPER WITH ANY COMPONENT OF LID LOCKING MECHANISM.



5

3-2. LID OPERATION
(Continued)



1



2



3

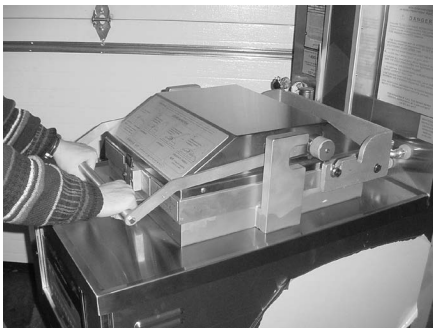

4



5

To open lid:



DO NOT LIFT HANDLE OR FORCE LID LATCH OPEN BEFORE PRESSURE GAUGE READS "0" PSI. ESCAPING STEAM AND SHORTENING WILL RESULT IN SEVERE BURNS.

1. Gently raise handle until it stops.

2. Push handle back until it stops.

3. Lower handle.











Lower the handle before attempting to raise the lid, or damage to the lid could result.

4. Push handle back.





5. Unlatch the front lid latch and raise the lid.

3-3. SWITCHES AND INDICATORS

Refer to image at end of this section.

Fig. No.	Item No.	Description	Function
3-1	1		Lights when the control calls for heat; the elements come on and heats the shortening.
3-1	2	Digital Display	Shows all the functions of the Cooking Cycle, Program Modes, Diagnostic Modes, and alarms
3-1	3		Lights when the solenoid closes and pressure starts to build inside frypot
3-1	4		Flashes when the shortening temperature is <u>not</u> at the proper temperature for cooking product
3-1	5		Lights when the shortening temperature is 5° F below to 15° F above the cooking temperature, signaling the operator that the shortening temperature <u>is</u> at the proper temperature for cooking product
3-1	6		<p>Press to display the following fryer information and status:</p> <ol style="list-style-type: none"> The temperature of the shortening The temperature setpoint Filter status The number of times filtered today The average no. of filters per day No. of times Cook Cycle was stopped early today No. of times Cook Cycle was stopped early in past week Oil Life Display (Only if “Change Oil” feature is enabled) Date and time <p>If pressed in the Program Mode, shows previous settings.;</p> <p>pressing this along with  accesses the Information Mode which has historic information on the operator and fryer’s performance</p>
3-1	7 & 8	 	Used to adjust the value of the currently displayed setting in the Program modes

3-3. SWITCHES AND INDICATORS (Continued)

Fig. No.	Item No.	Description	Function
3-1	9		Press to access Program Modes; once in the Program Mode, it is used to advance to the next setting; if pressed along with  it accesses the Information Mode which has historic information on the operator and fryer's performance
3-1	10		Used to start and stop Cook Cycles, and to stop the timer at the end of a Holding Cycle
3-1	11	Menu Card Window	The name of the food product associated with each product selection button; the menu card strip is located behind the decal.
3-1	12	Product Select Buttons	Are used to select the product for cooking; to use them to start Cook Cycles, see section 3, Special Program Mode item SP-10
3-1	13	COOK/PUMP Switch	A 3-way switch with a center OFF position; turn the switch to the COOK position to operate the fryer; turn the switch to the PUMP position to operate the filter pump; certain conditions must be met before operating the filter pump; these conditions are covered later in the Filtering Instructions Section of this manual
3-1	14		Used to manually enter an Idle mode, or Clean-Out Mode

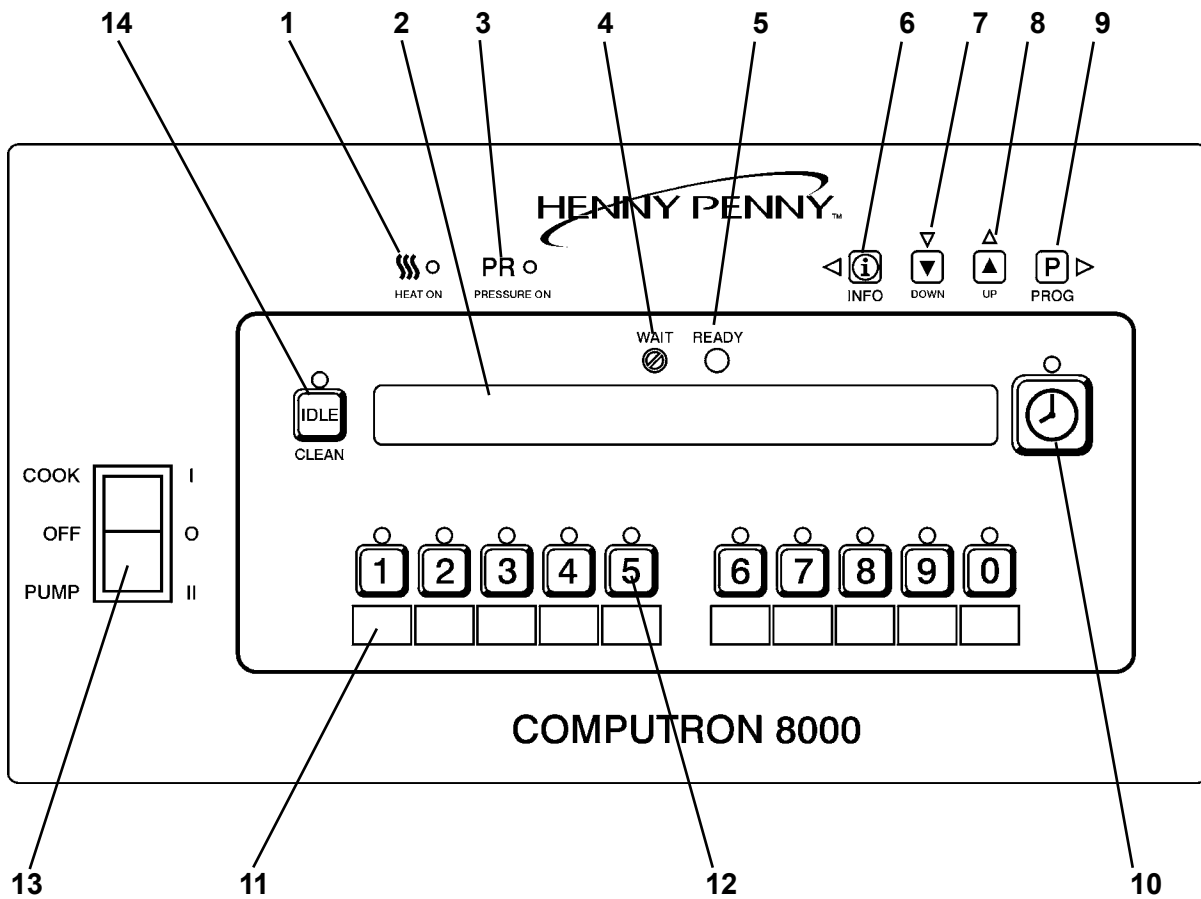





















Figure 3-1

3-4. CLOCK SET



NOTICE

Upon initial start-up, or PC board replacement, if “CLOCK SET” automatically appears in the display, start with step 4.



1. Press and hold  for 5 seconds until “LEVEL 2” shows in display.
2. Press  and “CLOCK SET”, “ENTER CODE” shows in display.
3. Press   .
4. “CS-1, SET, MONTH”, and the month flashes in the display.
5. Press the   to change the month.
6. Press  and “CS-2, SET, DATE” shows in the display, with the date flashing.
7. Press   to change the date.
8. Press  and “CS-3, SET, YEAR” shows in the display, along with the year flashing.
9. Press   to change the year.
10. Press  and “CS-4, SET, HOUR” shows in the display, with the hour and “AM” or “PM” flashing.
11. Press   to change the hour and AM/PM setting.
12. Press  and “CS-5, SET, MINUTE” shows in the display, with the minutes flashing.
13. Press   to change the minutes.

3-4. CLOCK SET
(Continued)

14. Press  and “CS-6, CLOCK MODE” shows in the display, along with “1.AM/PM”.

“1.AM/PM” is 12 hour time, “2.24-HR” is 24 hour time. Press   to change.



15. Press  and “CS-7, DAYLIGHT SAVINGS ADJ” shows in the display, along with “2.US”.

Press   to change to the following:

- a. “1.OFF” = No automatic adjustments for daylight savings time.
 - b. “2.US” = Automatically applies United States daylight savings time adjustment. DST activated on the first Sunday in April. DST de-activated on the last Sunday in October.
 - c. “3.EURO” = Automatically applies European (CE) daylight saving time adjustment. DST activated on the last Sunday in March. DST de-activated on the last Sunday in October.
16. Press  and “CS-8, BEGIN NEW DAY” shows in display, along with “3:00AM”.

This setting indicates the time of day that statistics start accumulating for a new day. If set to 3:00AM, for example, then late night cook cycles and filter operations from midnight to 3:00AM Tuesday morning, are accumulated with Monday’s statistics.

The CS-8 value can be set from 12:00AM (midnight) to 8:00AM, in half hour increments (12:00 AM, 12:30 AM, 1:00 AM, 1:30 AM, etc.). The default value for general market software is 3:00 AM.

Press   to change the time the “new” day starts.

17. Clock Set is now complete. Press and hold  to exit.

**3-5. FILLING OR ADDING
SHORTENING**

CAUTION

The shortening level must always be above the heating elements when the fryer is heating and at the frypot level indicators on the rear of the frypot (Figure 3-3). Failure to follow these instructions could result in a fire and/or damage to the fryer.

When using solid shortening, it is recommended to melt the shortening on an outside heating source before placing it in the frypots. The heating elements must be completely submerged in shortening. Fire or damage to the frypot could result.

1. It is recommended that a high quality frying shortening be used in the open fryer. Some low grade shortenings have a high moisture content and will cause foaming and boiling over.



To avoid severe burns when pouring hot shortening into frypot, wear gloves and take care to avoid splashing.

2. The electric model requires 100 lbs.(45 Kg.) of shortening. The frypot has two level indicator lines inscribed on the rear wall of the frypot which show when the heated shortening is at the proper level.
3. Cold shortening should be filled to lower indicator.

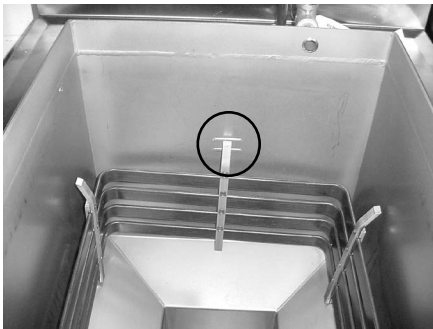

BE CERTAIN THE SHORTENING IS NEVER ABOVE THE UPPER LEVEL INDICATOR LINE. FAILURE TO FOLLOW THESE INSTRUCTIONS CAN RESULT IN SHORTENING OVERFLOWING THE FRYPOT CAUSING SERIOUS BURNS, PERSONAL INJURY, FIRE AND/OR PROPERTY DAMAGE.

3-6. PRODUCT RACKING RECOMMENDATIONS

The rack positions are referenced starting at the bottom:

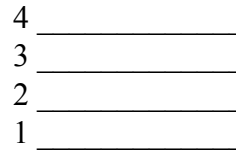

The bottom position is to be avoided on small loads because it is closer to the cold zone. (The oil is cooler at the bottom of the frypot and hotter at the top.) With bigger loads, however, there is generally enough turbulence in the oil that the bottom rack gets sufficient heat.

The top position is to be avoided on small loads because of insufficient oil coverage. With bigger loads, the top rack has good oil coverage because the volume of product on the lower racks raises the overall oil level.

Cooking ONE rack
(2-head load)

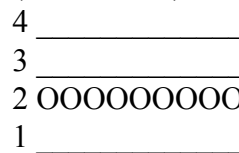

Cooking TWO racks
(4-head load)

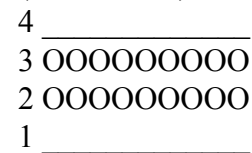

Cooking THREE racks
(6-head load)

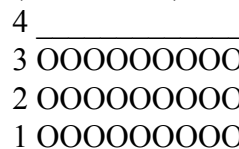

Cooking FOUR racks
(8-head load)

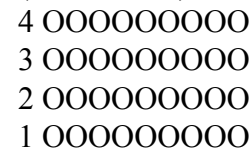

3-7. BASIC OPERATION

Follow the procedures below on the initial start-up of the fryer, and each time the fryer is brought from a cold, or shut down condition.

1. Make sure the frypot is filled with shortening to the lower level indicator.



DO NOT OVERLOAD, OR PLACE PRODUCT WITH EXTREME MOISTURE CONTENT INTO THE RACKS. 21 LBS. (9.5 KG.) IS THE MAXIMUM AMOUNT OF PRODUCT PER FRYPOT. FAILURE TO FOLLOW THESE INSTRUCTIONS CAN RESULT IN SHORTENING OVERFLOWING THE FRYPOT WHICH COULD CAUSE SERIOUS BURNS, PERSONAL INJURY, FIRE AND/OR PROPERTY DAMAGE.

2. Turn the COOK/PUMP switch to the COOK position and press the appropriate product button to select the product to be cooked. Unit automatically goes into the Melt Cycle. When temperature reaches 250° F (121° C) the controls goes into the Heat Cycle, and heats the shortening to the setpoint temperature.
3. Stir the shortening as it's heating up from a "cold" start. Be sure to stir down into the "cold zone".



DO NOT STIR THE SHORTENING AT ANY OTHER TIME EXCEPT AT MORNING START-UP. FAILURE TO FOLLOW THESE INSTRUCTIONS CAN RESULT IN SHORTENING OVERFLOWING THE FRYPOT WHICH COULD CAUSE SERIOUS BURNS, PERSONAL INJURY, FIRE, AND/OR PROPERTY DAMAGE

3-7. BASIC OPERATION
(Continued)

4. Allow fryer to heat until ^{READY}  illuminates.

NOTICE



Bypass Melt Cycle, if desired, by pressing a product button and holding it for five seconds. The display shows “EXIT MELT? 1=YES 2=NO”. Press  to exit melt.

CAUTION

Do not bypass the Melt Cycle unless enough shortening has melted to completely cover all of the heating elements. If the Melt Cycle is bypassed before all heating elements are covered, excessive smoking of shortening, or a fire could result.



NOTICE

The heat cycles on and off about 10 degrees before the setpoint temperature, to help prevent overshooting the setpoint temperature. (proportional control)

Once out of the Melt Cycle, ^{WAIT}  flashes until 5° before setpoint temperature is reached. Then ^{READY}  illuminates and the selected product shows in the display.

5. Before loading product onto the racks, lower the racks into the hot shortening to prevent the product sticking to the racks.
6. Slide racks of breaded product into carrier on the lid, starting with the bottom tier, to avoid damaged product.
7. Lower and lock the lid, and press .

NOTICE

A different product can be selected during the first minute of cooking, in case the wrong Product Button was pressed. To check the shortening temperature press  or to stop a cook cycle, press . **INFO**

8. At the end of the cycle, the pressure vents automatically and an alarm sounds, while the display shows “DONE”.



3-7. BASIC OPERATION
(Continued)

8. Wait for the pressure gauge to show “0” pressure in the pot before attempting to open the lid.



DO NOT LIFT HANDLE OR FORCE LID LATCH OPEN BEFORE PRESSURE GAUGE READS “0” PSI. ESCAPING STEAM AND SHORTENING WILL RESULT IN SEVERE BURNS.

10. Unlock and raise the lid cautiously.
11. Using the rack handles, remove the racks of product from the carrier, starting with the top rack, to avoid damage product.
12. If a Quality time (hold time) was programmed, the controller automatically starts the hold timer. The display alternately shows the product selected and the quality time remaining in minutes. If a different product is selected during the Hold Cycle, the display only shows the product selected.
13. At the end of the Hold Mode, a tone sounds, the display flashes “QUALITY”, and the product it was timing. Press and release .

NOTICE

In a Cook Cycle, when “FILTER SUGGESTED”, shows in the display, the operator has the option to filter at this time, or to continue cooking. But, if the operator continues cooking, a Filter Lockout occurs within the next Cook Cycle, or two.

When “FILTER LOCKOUT”, then “YOU *MUST* FILTER NOW.....” shows in the display,  is the only

button that functions, until the unit is filtered. Follow the filtering instructions in this manual.

3-7. BASIC OPERATION
(Continued)

Once filtering is complete and the COOK/PUMP switch is turned back on, “IS POT FILLED” shows in the display, followed by “1=YES 2=NO”.

If shortening is at the proper level in the frypot, press  and the controls start a normal heating process.

If shortening is NOT at the proper level, press  and “TURN OFF UNTIL FILLED...” scrolls through the display. Turn the COOK/PUMP switch to the OFF position, fill frypot to the proper level, then turn the COOK/PUMP switch back to the COOK position.

Again, “IS POT FILLED” shows in the display, followed by “1=YES 2=NO”. This time press  and unit resumes normal heating process.

CAUTION

When the fryer is heating, the shortening level must always be above the heating elements. Failure to follow these instructions could result in a fire and/or damage to the fryer.

3-8. CARE OF THE SHORTENING



FOLLOW THE INSTRUCTIONS BELOW TO AVOID SHORTENING OVERFLOWING THE FRY POT, WHICH COULD RESULT IN SERIOUS BURNS, PERSONAL INJURY, FIRE, AND/OR PROPERTY DAMAGE.

1. To protect the shortening when the fryer is not in immediate use, the fryer should be put into the Idle Mode.
2. Frying breaded products requires filtering to keep the shortening clean. The shortening should be filtered at least twice a day; after lunch rush and at the end of the day.

**3-8. CARE OF THE
SHORTENING (Continued)**

3. Maintain the shortening at the proper cooking level. Add fresh shortening as needed.
4. Do not overload the baskets with product (21 lb (9.5 kg) max), or place product with extreme moisture content into baskets.



WITH PROLONGED USE, THE FLASHPOINT OF SHORTENING IS REDUCED. DISCARD SHORTENING IF IT SHOWS SIGNS OF EXCESSIVE SMOKING OR FOAMING. SERIOUS BURNS, PERSONAL INJURY, FIRE, AND/OR PROPERTY DAMAGE COULD RESULT.

**3-9. FILTERING
INSTRUCTIONS**

The Henny Penny Electric 8 Head Fryer, Model PFE-591, must be cleaned and the shortening filtered at least twice daily; after lunch rush and at the end of the day.



Drain the shortening at 275° F (135° C) or less. The higher temperatures cause cracklings to burn on the steel frypot surfaces after the shortening has drained.



FILTER ONLY WHEN THE SHORTENING TEMPERATURE IS LESS THAN 275° F (135° C). FAILURE TO DO SO CAN RESULT IN SHORTENING OVERFLOWING THE FRYPOT, CAUSING SERIOUS BURNS, PERSONAL INJURY, AND/OR PROPERTY DAMAGE.

3-9. FILTERING
INSTRUCTIONS
(Continued)

High volume cooking could cause the cold zone to fill quicker with cracklings and cleaning may be required more often. Part of the process involves removing cracklings from the cold zone of the frypot.

1. Turn COOK/PUMP switch to OFF position.
2. Make sure filter drain pan is under fryer and the filter union is tightened to the standpipe, coming out of the pan.



The filter drain pan must be as far back under fryer as it will go, and the cover in place. Be sure the hole in the cover lines up with the drain before opening the drain. Failure to follow these instructions causes splashing of shortening and could result in personal injury.

Surfaces of fryer and racks will be hot. Use care when filtering to avoid getting burned.

3. Remove cooking racks and carrier, and wipe bottom of lid. Tilt lid out of the way to clean frypot.
4. Pull drain handle towards you to open drain valve. The handle should point straight out to the front of the fryer. Use L-shaped brush to clean cracklings from the heating elements and from sides and bottom of frypot as shortening drains. Use straight brush to push cracklings through drain opening in bottom of frypot if necessary, and to clean between the heating elements and the frypot wall.

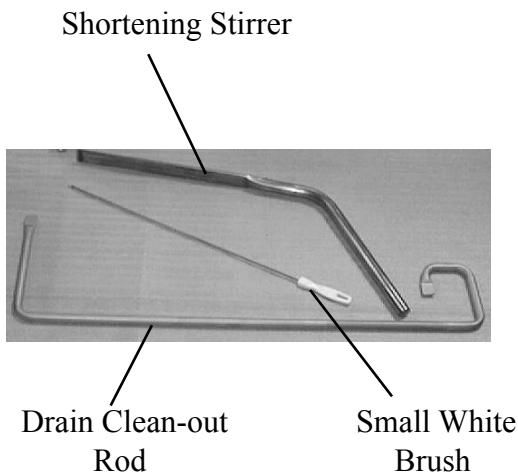

BRUSH ALL CRACKLINGS FROM FRYPOT SURFACES AND THE COLD ZONE DURING THE FILTERING PROCESS. FAILURE TO DO SO CAN RESULT IN SHORTENING OVERFLOWING THE FRYPOT, WHICH COULD CAUSE SERIOUS BURNS, PERSONAL INJURY, FIRE AND/OR PROPERTY DAMAGE.

3-9. FILTERING INSTRUCTIONS
(Continued)

5. When all of the shortening has drained, scrape or brush the sides and bottom of the frypot, and swing drain valve handle to the closed position.

CAUTION

Do not bang the pot scraper, or other cleaning utensil, on the frypot rim. Damage to the frypot rim could result and the lid may not seal properly during a cook cycle.

6. If an optional filter rinse hose is available on your fryer, the following cleaning procedure may be used, otherwise continue onto step 7.
- a. Attach the filter rinse hose with its quick disconnect fitting to the male fitting, located next to the filter valve handle. Slide back the spring ring on the female side of the quick disconnect fitting and let it snap into place over the male half of the fitting.
 - b. Make sure the hose nozzle is pointed down into the bottom of the frypot and filter valve is in closed position. Move the COOK/PUMP switch to the PUMP position. Hold nozzle carefully to avoid excessive splashing.



Use care to prevent burns caused by splashing of hot shortening.

- c. Rinse the frypot interior. Especially work on hard to clean areas, like the frypot bottom and burner tubes.
- d. After thorough rinsing with shortening, close drain valve.
- e. Turn the COOK/PUMP switch to the OFF position.



ONLY CONNECT AND DISCONNECT THE FILTER RINSE HOSE WHEN THE MAIN POWER SWITCH IS IN THE OFF POSITION. ALSO, USE A DRY CLOTH OR GLOVE TO AVOID BURNS. FAILURE TO DO THIS COULD RESULT IN SEVERE BURNS FROM HOT SHORTENING SPRAYING FROM THE MALE FITTING.

- f. Detach the hose and raise the fitting end of hose high for a minute to allow the remaining shortening in the hose to drain into the frypot.

3-9. FILTERING INSTRUCTIONS
(Continued)

7. Turn COOK/PUMP switch to PUMP.
8. When all shortening has been pumped into frypot turn COOK/PUMP switch off.



IF THERE ARE AIR BUBBLES COMING UP IN THE SHORTENING, IT'S POSSIBLE THAT THE FILTER CONNECTION AT THE UNION ON THE FILTER TUBE IS NOT TIGHTENED PROPERLY. IF SO, TURN OFF THE PUMP AND USE PROTECTIVE CLOTH OR GLOVE WHEN TIGHTENING THE UNION. THIS UNION WILL BE HOT AND SEVERE BURNS COULD RESULT.

3-10. CHANGING THE FILTER ENVELOPE

The filter envelope should be changed after 10-12 filterings, or whenever it becomes clogged with crumbs. Proceed as follows:

1. Move the COOK/PUMP switch to the OFF position.
2. Remove and empty the condensation drain pan.
3. Disconnect the filter union and remove the filter drain pan from beneath the frypot.



Use protective cloth or glove when disconnecting the filter union or severe burns could result.

If the filter pan is moved while full of shortening, use care to prevent splashing, or severe burns could result.

4. Lift the filter screen assembly from the drain pan.
5. Wipe the shortening and crumbs from the filter drain pan. Clean the filter drain pan with soap and water. Thoroughly rinse with hot water.
6. Unthread the standpipe from the filter screen assembly.
7. Remove the crumb catcher and clean thoroughly with hot water.

**3-10. CHANGING THE FILTER
ENVELOPE (Continued)**

8. Remove the filter clips and discard the filter envelope.
9. Clean the top and bottom filter screen with soap and water. Rinse thoroughly with hot water.

CAUTION

Be sure that the filter screens, crumb catcher, filter clips, and the standpipe are thoroughly dry before assembly of filter envelope as water will dissolve the filter paper.

10. Assemble the top filter screen to the bottom filter screen.
11. Slide the screens into a clean filter envelope.
12. Fold the corners in and then double fold the open end.
13. Clamp the envelope in place with the two filter retaining clips.
14. Replace the crumb catcher screen on top of the filter paper. Screw on the suction standpipe assembly.
15. Place complete filter screen assembly back into filter drain pan, replace clean crumb basket, and slide pan back into place beneath the fryer.
16. Connect the filter union by hand. Do not use a wrench to tighten.
17. Slide the condensation drain pan back into place. The fryer is now ready to operate.

3-11. FILTER PUMP MOTOR PROTECTOR-MANUAL RESET



The filter pump motor is equipped with a manual reset button, located on the rear of the motor, in case the motor overheats. If motor won't run, wait about 5 minutes before attempting to reset this protective device to allow motor to cool. Remove the access panel on the left side panel of the unit to reset the button. It takes some effort to push the reset, and a screwdriver can be used to help reset the button.



To prevent burns caused by splashing shortening, turn the unit's main power switch to the OFF position before resetting the filter pump motor's manual reset protection device.

3-12. CLEANING THE FRYPOT

After the initial installation of the fryer, as well as before every change of shortening, the frypot should be thoroughly cleaned as follows:

1. Turn the COOK/PUMP switch to OFF.



Moving the fryer or filter drain pan while containing hot shortening is not recommended. Hot shortening can splash out and severe burns could result.

The filter drain pan must be as far back under fryer as it will go, and the cover in place. Be sure the hole in the cover lines up with the drain before opening the drain. Failure to follow these instructions causes splashing of shortening and could result in personal injury.

2. If hot shortening is present in the frypot, it must be drained by slowly pulling the drain handle out towards you.
3. Close the drain valve and discard the shortening.
4. Raise lid, remove the racks and carrier from lid, and tilt lid back, so that the lid won't interfere with cleaning.



Henny Penny has the following cleaners available:
Foaming Degreaser - Part no. 12226
PHT Liquid Cleaner - Part no. 12135
PHT Dry Powder Cleaner - Part no. 12101
See your local distributor for details.

3-12. CLEANING THE FRYPOT
(Continued)

- Fill the frypot to the level indicators with hot water. Add 8 to 10 ounces of fryer cleaner (Henny Penny part number 12101) to the water and mix thoroughly.









Always wear chemical splash goggles or face shield and protective rubber gloves when cleaning the frypot as the cleaning solution is highly alkaline. Avoid splashing or other contact of the solution with your eyes or skin. Severe burns and possible blindness will result. Carefully read the instructions on the cleaner. If solution comes in contact with your eyes, rinse thoroughly with cool water and see a physician immediately.



CHEMICAL
SPLASH
GOGGLES



CHEMICAL
RESISTANT
GLOVES

- Turn the COOK/PUMP switch to COOK and enter the Clean-Out Mode by pressing and holding  until "CLEAN OUT?", "1=YES 2=NO" shows  display. Press  to start Clean-Out Mode. The fryer displays " *CLEAN-OUT MODE*" and heats up to a preprogrammed temperature (195°F (91°C max.) then automatically begins a preset timed countdown. Use  if necessary, to adjust the temperature and  to keep cleaning solution from boiling over.



DO NOT CLOSE LID WITH WATER AND/OR CLEANER IN FRYPOT. WATER UNDER PRESSURE BECOMES SUPERHEATED. WHEN LID IS OPENED, ESCAPING WATER AND STEAM WILL RESULT IN SEVERE BURNS.



Watch the cleaning solution constantly to make sure it does not boil over causing damage to controls.

Do not use steel wool, other abrasive cleaners or cleaners/sanitizers containing chlorine, bromine, iodine or ammonia chemicals, as these will deteriorate the stainless steel material and shorten the life of the unit.

Do not use a water jet (pressure sprayer) to clean the unit, or component failure could result.

3-12. CLEANING THE FRYPOT
(Continued)



If the cleaning solution in the frypot starts to foam and boil over, immediately turn the power switch to OFF and do not try to contain it by closing the fryer lid or severe burns could result.

7. Using the fryer brush (Henny Penny part number 12105) scrub the inside of the frypot, the lid frame, and around the counter-top of the fryer.
8. After cleaning, turn off the COOK/PUMP switch. Open the drain valve and drain the cleaning solution from the frypot into the filter drain pan and discard.
9. Close the drain valve and refill the frypot with plain hot water to upper level indicator line.
10. Add approximately 16 ounces of distilled vinegar and enter the Clean-Out Mode again (see step 6).
12. Using a clean brush, scrub the interior of the frypot and lid liner. This will neutralize the alkaline left by the cleaning compound.
13. Drain the vinegar rinse water and discard.
14. Rinse down the frypot, using clean hot water.
15. Thoroughly dry the filter drain pan, and the frypot interior.



Make sure the inside of the frypot, the drain valve opening, and all parts that come in contact with the new shortening are as dry as possible.

16. Replace the clean filter screen assembly in the filter drain pan and install under fryer.
17. Refill the fryer with fresh shortening

3-13. REGULAR MAINTENANCE

As in all food service equipment, the Henny Penny pressure fryer does require care and proper maintenance. The table below provides a summary of scheduled maintenance. The following paragraphs provide step-by-step maintenance procedures to be performed by the operator.

Procedure	Frequency
Filtering of shortening	Daily (at least twice a day)
Changing of shortening	As required
Changing the filter envelope	After 10-12 filterings or when clogge
Cleaning the frypot	Upon initial installation and everychange of shortening
Cleaning the deadwight assy.	Daily-see Preventive Maint. Section
Cleaning the Nylatrons	Monthly-see Preventive Maint.
Reversing lid gasket	Every 90 days-see Preventive Maint.
Clean safety relief valve	Annually-see Preventive Maint.
Inspect Counter-weight cables	Annually-see Preventive Maint.

3-14. PREVENTIVE MAINTENANCE



Cleaning the Nylatrons

1. Spray Henny Penny biodegradable, food safe, foaming degreaser (part no. 12226) on Nylatrons.
2. Raise lid up and down several times to spread the degreaser.
3. Wipe Nylatrons to remove food soil, grease, and degreaser residue.



Lubricating Lid Rollers

The lid rollers, in the back of the fryer, should be lubricated at least once a year, to allow the lid easy movement.

1. Remove the back shroud of the fryer.
2. Using spindle lube, part number 12124, place a small amount of lube on both top and bottom rollers. Make sure to lube both left and right rollers.

**3-14. PREVENTIVE
MAINTENANCE
(Continued)**

Cleaning Deadweight Assembly - Daily



DO NOT ATTEMPT TO REMOVE DEADWEIGHT CAP WHILE FRYER IS OPERATING. SEVERE BURNS OR OTHER INJURIES WILL RESULT.

1. At the end of each day's usage of the fryer, the dead weight assembly must be cleaned. The fryer must be OFF and the pressure released. Open the lid and then remove the deadweight valve cap and deadweight.

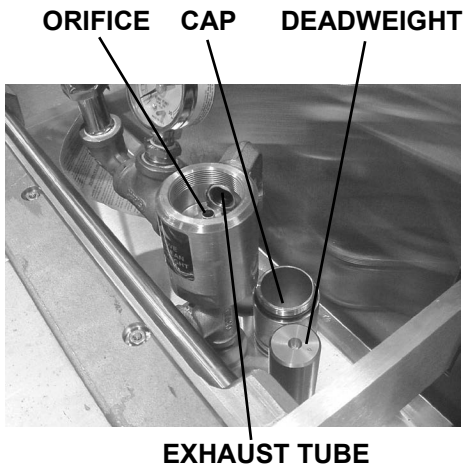

Deadweight cap may be hot. Use protective cloth or glove, or burns could result.

Failure to clean the deadweight assembly daily could result in the fryer building too much pressure. Severe injuries and burns could result.

2. Wipe both the cap and deadweight with a soft cloth. Make certain to thoroughly clean inside cap, the dead weight seat, and around deadweight orifice.
3. Clean the exhaust tube with stainless steel brush (Henny Penny part number 12147).
4. Dry parts and replace immediately to prevent damage or loss.

**3-14. PREVENTIVE
MAINTENANCE
Continued)**

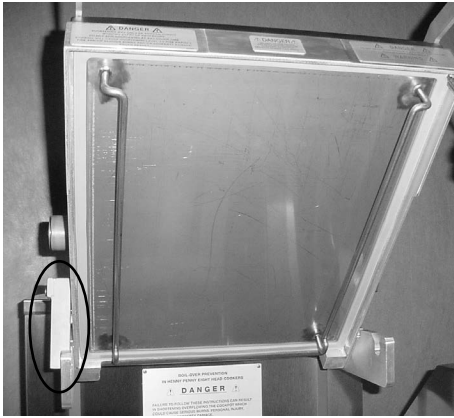

Reversing Lid Gasket - Every 90 Days

Reversing the lid gasket helps to prevent early failure of lid gasket and the loss of pressure during a cook cycle.

1. Raise the lid and remove racks and carrier.
2. Grasping the lid handle, lift the front of the lid up until it stops in an upright position.



Be sure the metal arm on the left side of the lid is in the vertical position holding the lid upright, or severe injuries could result. (See photo at left).

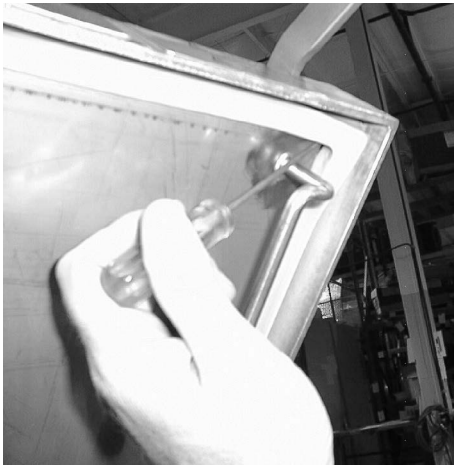

3. Using a thin blade screwdriver, pry out the gasket at the corners. Remove the gasket.



Check the gasket for any tears or nicks. If the gasket is damaged, it needs to be replaced.

4. Clean the gasket and gasket seat with hot water.
5. Rotate the gasket with the opposite side facing out.



Install the 4 corners of the lid gasket. Smooth the gasket into place, working from the corners towards the middle of each side.

**3-14. PREVENTIVE
MAINTENANCE
(Continued)**

SAFETY VALVE



Cleaning Safety Relief Valve-Annually



DO NOT ATTEMPT TO REMOVE SAFETY VALVE WHILE FRYER IS OPERATING, OR SEVERE BURNS OR OTHER INJURIES WILL RESULT.

1. Use a wrench to remove pressure gauge.
2. Use a wrench to loosen the valve from the pipe tee, turn counterclockwise to remove.



Turn the safety relief valve towards the rear of the fryer when reinstalling the relief valve.

3. Clean the inside of the pipe tee with hot water.
4. Immerse the safety relief valve in a soapy water solution for 24 hours. Use a 1 to 1 dilution rate. The valve cannot be disassembled. It is factory preset to open at 14-1/2 pounds of pressure. If it does not open or close, it must be replaced.



DO NOT DISASSEMBLE OR MODIFY THIS SAFETY VALVE. TAMPERING WITH THIS VALVE COULD CAUSE SERIOUS INJURIES AND WILL VOID AGENCY APPROVALS AND APPLIANCE WARRANTY.

**3-15. PREVENTIVE
MAINTENANCE
(Continued)**



FIGURE 1



FIGURE 2

Inspect Counter-weight Cables-Annually

Henny Penny 8 head fryers use two cables in the counter-weight mechanism that helps in the raising and lowering of the lid. Cables should be visually inspected yearly, either as part of a planned maintenance program or during a routine service call. Cables more than 10 years old should be replaced regardless of inspection results.

NOTICE

If lid becomes difficult to operate, stop using the fryer and call for service. Cables need replaced.

1. Using a 3/8" socket, remove the 6 keps nuts around exterior of rear cover, shown in Figure 1.
2. Lift up on the rear cover and pull out at the bottom to clear threaded studs. Figure 2. (Removing top shroud makes it easier to remove the rear cover, but is not necessary.)



View of the counter-weights
with cover removed

**3-15. PREVENTIVE
MAINTENANCE
Continued)**

Inspect Counter-weight Cables-Annually

3. Inspect the counter-weight cables. If cables have cracks in the jacket, missing pieces in the jacket, or other obvious signs of wear, call for service to have both cables replaced.

NOT OK - REPLACE
Cracks in jacket and obvious signs of wear.

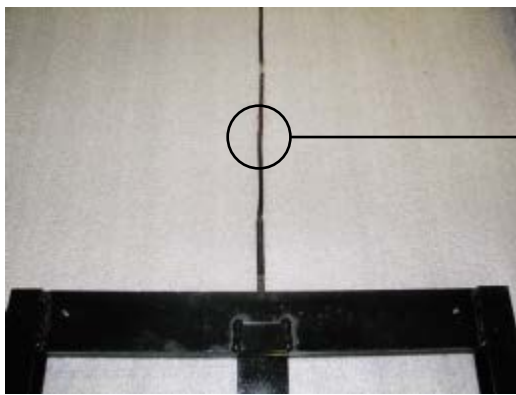

OK
No signs of cracking or wear.





3-16. PROGRAMMING

1. Press and hold  for one second until “PROG” shows in the display, followed by “ENTER CODE”.
2. Enter code 1, 2, 3. “SELECT PRODUCT...PRESS PROG” scrolls across the display.
3. Press and release the desired product button (1 to 10).













NOTICE

If no buttons are pressed within approximately 2 minutes while in the Program Mode, the controls will revert back to the Cook Mode.



Press  to copy a product, erase a product, preset a product, erase all products, or preset all products. See Copy/Erase Pre-Set Products Section.



4. Press and release  . The name of that product shows in the display. Ex. “NAME“FRIES”.

Change Product Names



- a. Press and release   and the first letter, or digit, starts flashing.
 - b. Press and release   to change the flashing letter.
 - c. To continue to the next letter, press  . Then press   to change this letter.
 - d. Repeat step c until up to 7 letters are entered.
 - e. Press and hold  to exit Program Mode, or press and release  until “PRELOAD” shows in display, to continue with Program Mode.
5. The Preload Mode allows the operator to drop large pieces first, with the lid up, before loading the rest of the product. The preload cycle always runs without pressure and which always regulates to the Step 1 cook temperature. Press   to set a preload time, or press  if no preload is desired.





3-16. PROGRAMMING
(continued)

6. Press and release  and “1. COOK TIME” shows in the display along with the preset time. Press   to change the time. The time shows in minutes and seconds. Press and hold the buttons, and the time jumps by 5 second increments to a maximum of 59:59.

7. Press and release  and “1. TEMP” shows in the display, along with the preset temperature on the right side of the display. Press   to change the temperature.



Press and hold the buttons and the temperature jumps by 5 degree increments to a max. of 380°F (193°C), and a min. of 190°F (88°C).

8. Press and release  and “1. PRESSURE” shows in the display along with “YES” or “NO”. Press   to build pressure in the first step, or not.



9. Press and release  and “2. STEP 2 AT” shows in display, along with a step 2 time. If no step 2 is desired, set time to “0:00” and press . If a step 2 is desired, press   and set a time. Then press  to set temperature and pressure.

NOTICE

Up to 10 steps can be programmed for a product, repeating the above step for each cooking step.

10. Press and release  and “ALARM – 1 AT 0:00” shows in the display. Press   to set an alarm. Ex: If a Cook Cycle was set at 3 minutes, and an alarm was to go off after 30 seconds into the cook cycle, “2:30” would be set in the display at this time. When the timer counts down to 2:30 the alarm sounds.



3-16. PROGRAMMING
(continued)

After the alarm time is set, press  and “ALARM” and “TYPE” flashes in the display, with the alarm type on the right side of the display. “TIME”, “SHAKE”, “STIR”, “ADD”, and “LID” can be set by pressing  . An alarm

sounds and alarm type flashes, prompting the operator to shake the basket, stir the product, or add product. If “TIME” is selected, the time remaining flashes in the display. If “LID” is selected, “CLOSE LID” flashes in the display. The timer count-down is paused until the lid is closed and  is pressed to restart the timer.



NOTICE



Up to 4 alarms can be programmed. After the first one is set, the other alarms can be accessed by pressing  again.

11. Press and release  until “QUALITY TMR” shows in the display along with the preset holding time. Press and release   to adjust the holding time, up to 59:59.

NOTICE

To exit the Program Mode at any time, press and hold  for 2 seconds.



12. Press and release  and “LOAD COMP” shows in the display along with the load compensation value. This automatically adjusts the time to account for the size and temperature of the cooking load. Press and release   to change this value to a max. of 20 and a min. of 0 or “OFF”. Preset at factory at 5.

13. Press and release  and “LCOMP REF” shows in the display (if load compensation is set to “OFF”, then “_ _ _” shows in display) along with the load compensation average temperature. This is your average cooking temperature for the products you cook. The timer speeds up at temperature above this setting and slows down at temperatures below this setting.   release To change this value.

3-16. PROGRAMMING
(Continued)

Or, to use the cooking setpoint temperature as the load compensation reference point, press  until “STEP-X” and “TEMP” flashes in the display. Now for example, if the cooking temperature is 350°, the timer speeds up when the shortening temperature is above 350, and slows down when the temperature is below 350.

14. Go to Idle after Done?



Press and release  and “GO TO IDLE, AFTER DONE” shows in the display, along with “YES” or “NO”. Press   to toggle between YES and NO.

15. Filter Cycle Mode (Optional)



For “FILTER AFTER” to appear in the Product Program Mode, the Filter Tracking must be enabled in the Special Program Mode. You have the option to program “**mixed**” (each product has its own filter count) or “**global**” (all products have the same count).

Press .

“2,Mixed”

- a. “FILTER AFTER” shows in the display, along with the preset number of Cook Cycles.
- b. Press and release   until the desired number of Cook Cycles between filters shows in the display. For example, if 4 is set for a product, each time that product is selected, it counts 1/4, or 25%. Then each time a product is cooked, the percentages add up until 100%, or more is reached. Then display shows “FILTER SUGGESTED”.





“3,GLOBAL”

- a. “FILTER INCL” shows in the display, along with “NO” or “YES”
- b. Press and release   to “YES” if that product is to be included in the filter count, or “NO” if it is not.

3-16. PROGRAMMING
(Continued)

Copy/Erase Pre-set Products

Products and their setpoints can be copied from one menu location on the controller to another location, preset the controls to factory settings, or erase products and all their values.

1. Press and hold  for one second until “PROG” shows in the display, followed by “ENTER CODE”.
2. Enter code 1, 2, 3. “SELECT PRODUCT...PRESS PROG” scrolls across the display, followed by “DOWN” FOR OPTIONS”
3. Press  and “**OPTION**”, followed by  “*1. COPY A PROD” shows in display. Press  again, each time, to view the following options:
 - *1. COPY A PROD
 - *2. ERASE A PROD
 - *3. PRESET A PROD
 - *4. ERASE ALL
 - *5. PRESET ALL
4. To select one of the above options, press  while the desired option shows in display.

Selecting PRESET A PROD, or PRESET ALL PROD sets factory setpoints in those menu items.





NOTICE

Press  at any time to exit the Options menu, or wait 30 seconds and controller automatically exits.

The following are examples of copying and erasing products:

Copying

Press  to select the presently displayed “COPY A PROD” option. “COPY __ TO __” shows in display.

The first set of “_” is blinking. Select the product you wish to copy *from*. For example, by pressing the  button: “COPY 2 TO __” shows in display.

3-16. PROGRAMMING
(Continued)

Next, press product you want to copy *to*, for example, by pressing  .

The controller responds with a confirmation message:
“COPY 2 TO 0?”
“1=YES 2=NO”

Press  (YES) and the controller copies product #2 to the product #0 position (the #2 product is left intact) and the display shows “* COPIED *”, then returns to the “Select Prog Product” step with the #0 product already selected.

Press  (NO), or don't press any button for 20 seconds, the controller displays “X CANCELED X” and exits the copy process. In this case no changes are made.

Erasing

On the “Select Prog Product” step, press  .
“** OPTIONS **” followed by “*1. COPY A PROD” shows in display.

Press  three more times to reach the “Erase All” option:
“*2. ERASE A PROD” (erases a single product)
“*3. PRESET A PROD” (sets factory settings)
“*4. ERASE ALL”

Press  to select the presently displayed “Erase All” option. The controller responds with a confirmation message:

“ERASE ALL PROD ?”
“1=YES 2=NO”

Press  (YES) to confirm that you want to erase all products back to “empty” values. The controller responds by erasing each product individually...

“ERASING 1”	“ERASING 6”
“ERASING 2”	“ERASING 7”
“ERASING 3”	“ERASING 8”
“ERASING 4”	“ERASING 9”
“ERASING 5”	“ERASING 0”

Then briefly displays “* ALL ERASED *” and finally, returns to the “Select Prog Product” display.

**3-17. SPECIAL PROGRAM
MODE**

The Special Program Mode is used to set more detailed parameters listed below.



- SP-1** · Degrees Fahrenheit or Celsius
- SP-2** · Language: English, French, German, Spanish, and Portuguese
- SP-3** · System initialization
- SP-4** · Audio volume
- SP-5** · Audio tone
- SP-6** · Type of shortening to be melted - liquid, solid
- SP-7** · Idle Mode
- SP-8** · Filter tracking
- SP-9** · Product buttons
- SP-10** · Clean-out minutes
- SP-11** · Clean-out temperature
- SP-12** · Nominal amps reading
- SP-13** · Amps reading low limit (percentage)
- SP-14** · Amps reading high limit (percentage)
- SP-15** · Program code change
- SP-16** · Usage code change
- SP-17** · Change shortening - A-Cook Cycles
- SP-18** · Change shortening - B-Hours

1. Press and hold  for 5 seconds until “L-2” and “LEVEL 2”, followed by, “SP PROG” and “ENTER CODE” shows in the display.
2. Enter code 1, 2, 3, and “SP- 1 “, “TEMP, UNITS” shows in the display.

NOTICE



If a bad code is entered, an alarm sounds and “BAD CODE” shows on the display. Wait a few seconds, the control reverts back to the Cook Mode, and repeat the above steps.

To exit from the Special Program Mode at any time, press

and hold  button for 2 seconds, or to roll back to previous setting, press  .



INFO

Degrees Fahrenheit or Celsius (SP-1)

- a. Follow steps 1 and 2 above.
- b. The display flashes “SP- 1” and “TEMP, UNITS” along with “°F” or “°C”. Press   buttons to toggle from “°F” to “°C”, or vice versa.



3-17. SPECIAL PROGRAM
MODE (Continued)

Language (SP-2)

- a. Follow steps 1 and 2 above.
- b. Press and release  button. “SP-2” and “LANGUAGE” flashes on the display, along with the language (Ex:” 1.ENGL”)
- c. To toggle to the desired language, press and release  



System Initialization (SP-3)

This step resets the controls, but doesn’t erase product settings.

- a. Follow steps 1 and 2 above.
- b. Press and release  twice. “SP-3” and “DO SYSTEM INIT” flashes on the display, along with “INIT”.
- c. Press and hold . “INIT” shows on the display, a tone sounds, and “IN 3”, “IN 2”, “ IN 1” flashes on the right side of the display. When “INIT” starts flashing on the left side of the display, release . When “ DONE” shows on the display, the initialization is complete, and the controls now have factory preset parameters.



Audio Volume (SP-4)

The volume of the speaker can be adjusted.

- a. Follow steps 1 and 2 above.
- b. Press  3 times. “SP-4” and “AUDIO VOLUME” flashes on the display, along with the volume value.
- c. Press   to adjust the speaker volume; 10 the maximum value and 1 the minimum.

Audio Tone (SP-5)



The tone of the speaker can be adjusted.

- a. Follow steps 1 and 2 above.
- b. Press  4 times. “SP-5” and “AUDIO TONE (HZ)” flashes on the display, along with the tone value.
- c. Press   to adjust the tone of the speaker; 2000 the maximum, 50 the minimum.

**3-17. SPECIAL PROGRAM
MODE (Continued)**

Type of shortening to be melted - Liquid or Solid (SP-6)

The Melt Cycle can be set to the type of shortening being used.

- a. Follow steps 1 and 2 above.
- b. Press and release  5 times. “SP-6”
PROG
and “MELT CYCLE SELECT” flashes on the display, along with “1=LIQ” or “2=SOLID”.
- c. Press   to toggle from one type to another.
DOWN UP





CAUTION

The type of shortening being used in the cooker determines the amount of heat applied during the Melt Cycle. If the controls are set to the solid setting, less heat is applied to the shortening, than if the controls were set to liquid. Too much heat applied to solid shortening causes much smoking, and could cause a fire. Match this setting to the type of shortening being used at the time.









When using solid shortening, it is recommended to melt the shortening on an outside source before placing shortening in the frypot. Unless elements are completely covered in shortening, fire or damage to the frypot could result.

Idle Mode (SP-7)

A programmed Idle Mode allows the shortening temperature to drop to a lower temperature when not in use. This saves on the shortening and utilities.



- a. Follow steps 1 and 2 above.
- b. Press and release  6 times. “SP-7” and “IDLE
PROG
MODE ENABLED?” flashes in the display, along with “NO” or “YES”.
- c. Press and release   to toggle from NO to YES, or vice versa.
DOWN UP
- d. With “YES” in the display, the Idle Mode is enabled.
Press and release  . “SP-7A” and
PROG
“IDLE SETPT TEMP” shows in the display, along with the preset temperature.

**3-17. SPECIAL PROGRAM
MODE (Continued)**

- e. Change the idle setpoint temperature, by pressing  
- f. Press and release  “SP-7B” and “AUTO-IDLE MINUTES” shows in the display, along with the preset time.
- g. Press   to set the minutes the fryer stays idle before the Auto-idle is enabled; 60 the maximum, OFF the minimum. Ex: “30” in the display means, if product is not cooked in that frypot for 30 minutes, the control automatically activates the idle setpoint temperature, programmed above.
- h. Press and release  . “SP-7C” and “GO IDLE AT MELT EXIT?” shows in display.
- i. Press   to toggle from NO to YES, or vice versa. With “YES” in the display, the fryer automatically enters the Idle Mode once the Melt Mode is exited.

Filter Tracking Enabled (Sp-8)







The controls can be set to signal the operator when the shortening needs filtering. The Filter Tracking must be enabled to program the number of Cook Cycles between filtering procedures. (See Filter Cycles section 2-2.)

- a. Follow steps 1 and 2 above.
- b. Press and release  until “SP-8” and “FILTER TRACKING ENABLED” flashes on the display, along with “1,OFF”.
- c. To enable the filter tracking, press   to toggle the display from “1,OFF”, to “2,MIXED”, to “3,GLOBAL”, or “4SCHEd”.







NOTICE

The Mixed setting allows the operator to set different amounts of Cook Cycles, between filters, for each product. If the operator wants to have one setting for all products go to step h.



MIXED

- d. If “2,MIXED” is selected, press  and “SP-8A” shows in the display followed by “SUGGEST FILTER AT ...” and a value between 75% and 100%. Press   the to change this value.
- e. Press  and “SP-8B” shows in the display followed by “LOCKOUT ENABLED?” and “YES” or “NO”. Press and release   to choose yes or no.

**3-17. SPECIAL PROGRAM
MODE (Continued)**

- f. Press  and “SP-8C” shows in the display, if YES was chosen in step e. “FILTER LOCKOUT AT...” and a value between 100% and 200% shows in display. Press   to change this value.
- g. Press  and “SP-8D” shows in the display, followed by “LOCKOUT-HEAT OIL...” and a temperature (preset at 300°F (149°C)). When a filter lockout occurs, the fryer heats up to this set temperature, and the display shows “FILTER LOCKOUT/WAIT”. Then once the set temperature is reached, “FILTER LOCKOUT”/ “YOU *MUST* FILTER NOW” shows in display. Use   to change this temperature setting.
- h. Now, go back to the Filter Cycle Mode step of the Programming Section, and program in the number of Cook Cycles between filtering.







GLOBAL

- i. If “3,GLOBAL” is selected, “SP-8A” shows in the display, and followed by “GLOBAL FILTER CYCLES”. The right side of the display shows a digit, 1 to 99. Press   to set the desired amount of Cook Cycles between filters.

NOTICE



In Cook Mode, the number of global Cook Cycles remaining shows in the center of the display.

Ex: “----- 5x -----”.

- j. Press  and “SP-8B” shows in the display followed by “LOCKOUT ENABLED?” and “YES” or “NO”. Press and release   to choose yes or no
- k. Press  and “SP-8D” shows in the display, followed by “LOCKOUT-HEAT OIL...” and a temperature (preset at 300°F (149°C)). When a filter lockout occurs, the fryer heats up to this set temperature, and the display shows “FILTER LOCKOUT/WAIT”. Then once the set temperature is reached, “FILTER LOCKOUT”/ “YOU *MUST* FILTER NOW” shows in display. Use   to change this temperature setting.
- l. Now, go back to the Filter Cycle Mode step of the Programming Section. Press  until “FILTER INCL” shows in the display. Each product must be set to YES” to be included in the filter tracking.

**3-17. SPECIAL PROGRAM
MODE (Continued)**

SCHEDULE

m. If “4,SCHED” is selected, “SP-8A” shows in the display, and followed by “SCHEDULE”. Press the  and up 

to 4 different times of day can be programmed, by pressing





EX:



SP-8A	“SCHEDULE”	F1: 10.00A
SP-8B	“SCHEDULE”	F2: 2.00P
SP-8C	“SCHEDULE”	F3: 8.00P
SP-8D	“SCHEDULE”	F4: - - - -



Unneeded times should be left at “- - - -”, otherwise, “Filter Suggested” shows in the display, prompting the operator to start filtering.

NOTICE

Cooking is still permitted during the “suggested” phase. However, if lockout is enabled, and the fryer still has not been filtered after one hour, then the controller activates lockout mode and prompts “FILTER LOCKOUT – YOU *MUST* FILTER NOW”.

n. Press  and “SP-8E” “SKIP IF LESS THAN...” shows in the display, followed by the number of loads between filters, ex: “LOAD 4”. In this example, if the suggested filter time occurs, before 4 loads have been cooked, then the filter operation is skipped. If more than 4 loads have been cooked, then “Filter Suggested” shows in the display. Set the numbers of loads by pressing  





o. Press  and “SP-8F” shows in the display, followed by “LOCKOUT ENABLED?” Press   to choose “YES” or “NO”.

p. Press  and “SP-8G” shows in the display followed by SP-8G “LOCKOUT - HEAT OIL...” and a shortening temperature, when reached, allows the operator to filter. Example, “LOCKOUT - HEAT OIL... 300F” means the display shows “FILTER LOCKOUT” “WAIT”, until 300F is reached, then display shows “FILTER LOCKOUT”/”YOU *MUST* FILTER NOW”, and repeated high-low tones are activated. This prompts the user that it is now \ time to filter the shortening. Press   to change.

3-17. SPECIAL PROGRAM MODE (Continued)



Product Buttons (Sp-9)

This mode allows you set up the way products are selected, and Cook Cycles started, in the cook mode.

- a. Follow steps 1 and 2 above.
- b. Press and release  until “SP-9” and “PRODUCT BUTTONS” flashes in the display.
- c. When using the first option, “1,COOK”, pressing a product button displays that product and starts the Cook Cycle. When nothing is cooking, no product displays.
- d. Press   to show the second option. If using “2,SELECT”, pressing a product button displays the product only. Press  to start the Cook Cycle.



Clean-Out Time (Sp-10)

Sets the number of minutes of the Clean-Out Mode.

- a. Follow steps 1 and 2 above.
- b. Press  until “SP-10” and “CLEAN-OUT MINUTES” shows in display, along with the preset minutes.
- c. Press   to change the number of minutes up to 99

Clean-Out Temperature (Sp-11)

Sets the temperature of the Clean-Out Mode Mode

- a. Follow steps 1 and 2 above.
- b. Press  until “SP-11” and “CLEAN-OUT TNP” shows in display, along with the set temperature.
- c. Press   to change the temperature, up to 195°F (91°C).

Nominal Amps Reading (SP-12)-not used on model 591

“SP-12”, “AMPS RDG, NOMINAL” should show on the left side of display, and “OFF” on the right side.

Amps Reading Low Limit (SP-13)-not used on model 591

“SP-13” and “AMPS RDG, LOW LIMIT” should show on the left side of display, and “OFF” on the right side.





Amps Reading High Limit (SP-14)-not used on model 591

“SP-14” and “AMPS RDG, HIGH LIMIT” should show on the left side of display, and “OFF” on the right side.

**3-17. SPECIAL PROGRAM
MODE (Continued)**





Manager Code Change (SP-15)

This allows the operator to change the program code, or manager code (factory set at 1, 2, 3) used to access Product Programming, Special Programming, Clock Set, Data Comm, and Heat Control Modes.

- a. Follows steps 1 and 2 above.
- b. Press  until “SP-15” and “CHANGE, MGR CODE? 1=YES” shows in display, along with “CODE”.
- c. Press . “ENTER NEW CODE, P=DONE, I=QUIT” shows in display. Press Product buttons with new code.
- d. If satisfied with code, press . “REPEAT NEW CODE, P=DONE, I=QUIT, shows in display. Press same code buttons in step c.
- e. If satisfied with code, press . “*CODE CHANGE*” shows in display.
- f. If not satisfied with code, press  and CANCELLED shows in display, then reverts back to “SP-15” and “CHANGE, MGR CODE, 1=YES”. Then the above steps can be repeated.

Usage Code Change (SP-16)

This allows the operator to change the usage code(factory set at 1, 2, 3) used to reset usage data in the Information Mode.

- a. Follows steps 1 and 2 above.
- b. Press  until “SP-16” and “CHANGE, USG CODE? 1=YES” shows in display, along with “CODE”.
- c. Press . “ENTER NEW CODE, P=DONE, I=QUIT” shows in display. Press Product buttons with new code.
- d. If satisfied with code, press . “REPEAT NEW CODE, P=DONE, I=QUIT, shows in display. Press same code buttons in step c.
- e. If satisfied with code, press . “*CODE CHANGE*” shows in display.
- f. If not satisfied with code, press  and CANCELLED shows in display, then reverts back to “SP-16” and “CHANGE, USG CODE, 1=YES”. Then the above steps can be repeated.

**3-17. SPECIAL PROGRAM
MODE (Continued)**

Change Shortening Cook Cycles (SP-17)



This mode allows the operator to set the number of Cook Cycles between shortening changes. When the set numbers of Cook Cycles is reached, the control displays “CHANGE OIL”. This mode is just a reminder and cooking can continue.

NOTICE

For this feature to operate, the operator must reset the Review Usage data in the Information Mode. See Review Usage step in Information Mode Section.

a. Follows steps 1 and 2 above.

b. Press  until “SP-17” and “CHANGE OIL A-COOK CYCLES” shows in display, along with the number of Cook Cycles or “OFF”.

c. Press   to change the number of Cook Cycles (“OFF” to 5000 cycles).

Change Shortening Cook Cycles (SP-18)



This mode allows the operator to set the number of power on hours between shortening changes. These hours are not only cooking time, but the total time the fryer is on. When the set numbers of hours are reached, the control displays “CHANGE OIL”. This mode is just a reminder and cooking can continue.

NOTICE

For this feature to operate, the operator must reset the Review Usage data in the Information Mode. See Review Usage step in Information Mode Section.

a. Follows steps 1 and 2 above.

b. Press  until “SP-18” & “CHANGE OIL B-HOURS” shows in display along with the number of hours or OFF.

c. Press   to change the number of hours. (“OFF” to 999 hours).



NOTICE



Press and hold  at any time to exit Special Program Mode.

**3-18. DATA LOGGING, HEAT
CONTROL, TECH MODE,
AND STAT MODE**

The Data Logging, Heat Control, Tech and Stat Modes are advanced diagnostic and program modes, mainly for Henny Penny use only. For more information on these Modes, contact the Service Department at 1-800-417- 8405, or 1-937-456-8405.

3-19. INFORMATION MODE

This mode gathers and stores historic information on the fryer and operator’s performance. Press  and  at the same time

and “*INFO MODE*” shows on display. Press  or 

to access the steps and press  to view the statistics within each step. Information Mode is intended for technical use, but the operator can view the following information:

1. **E-LOG** - last 10 errors and time they occurred
2. **LAST LOAD** - information about the most recent Cook Cycle, or the cycle presently in progress
3. **DAILY STATS** - information for the last 7 days.
4. **REVIEW USAGE**- information accumulated since the last time this data was manually reset
5. **INPA VHDSF M** - provides test of fryer inputs
6. **OUTP** - shows the state of heater and pressure
7. **OIL TMP** - temperature of shortening
8. **CPU TMP** - temperature of PC board
9. **ANALOG** - status of controller’s a-to-d converter

NOTICE

Press and hold  to exit Information Mode at any time, or after 2 minutes, controls automatically exit back to normal operation.

1. E-LOG (error code log)

Press  and “1A” (date & time) “*NOW*” shows in display. This is the present date and time.

Press  and if a error was recorded, “1B” (date, time, and error code information) shows in display. This is the latest error code that the controls recorded.

Press  and the next latest error code information can be seen. Up to 10 error codes (1B to 1K) can be stored in the E-LOG Section.

Press  to continue to LAST LOAD.

3-19. INFORMATION MODE

(Continued)

2. LAST LOAD

Press  to view the following information from the most



recent Cook Cycle.

FUNCTION	DISPLAY EX:
Time of day the last cook cycle was started	STARTED 10.25
Product (Last product cooked)	PRODUCT -2-
Ready? (Was fryer Ready before start?)	READY? YES
Stopped: Time remaining or secs past Done	*DONE* + 9 SECS
Actual Elapsed Cook Time (real seconds)	ACTUAL TIME 7:38
Programmed Cook Time	PROG TIME 7:00
Actual Time vs. Prog Time (Percentage)	ACT / PROG 109%
Max Temp during cook cycle	MAX TEMP 327°F
Min Temp during cook cycle	MIN TEMP 313°F
Avg Temp during cook cycle	AVG TEMP 322°F
Heat On (percentage) during cook cycle	HEAT ON 73%

Only if Presently Cooking:

Present cook step, setpoint, and time rem.	STEP 1: 325°F 6:47
Actual Oil Temp., Deg below Load Comp	
Avg, present Stretch Time (real secs/ck sec)	313°F LC-12° 1.06

Press  to continue to DAILY STATS.

3. DAILY STATS (reset each day)

Press  to view the following operation information for



any of the last 7 days. Press  to select which day.

FUNCTION	DISPLAY EX:
Day this data was recorded for	TUE* APR-30
Number of Hours:Minutes the fryer was on	TUE* ON HRS 13:45
Number of times oil was filtered that day	TUE* FILTERED 3
Total number of cook cycles that day	TUE* TOTAL CK 38
Cook Cycles stopped before "DONE" that day	TUE* QUIT COOK 4
Cook Cycles for Product #1	TUE* COOK -1- 17
Cook Cycles for Product #2	TUE* COOK -2- 9
Cook Cycles for Product #3	TUE* COOK -3- 5
Cook Cycles for Product #4	TUE* COOK -4- 0
Cook Cycles for Product #5	TUE* COOK -5- 0
Cook Cycles for Product #6	TUE* COOK -6- 6
Cook Cycles for Product #7	TUE* COOK -7- 0
Cook Cycles for Product #8	TUE* COOK -8- 0
Cook Cycles for Product #9	TUE* COOK -9- 1
Cook Cycles for Product #0	TUE* COOK -0- 0



3-19. INFORMATION MODE

(Continued)

4. REVIEW USAGE

Press  to view the accumulated information since the data was manually reset:

FUNCTION	DISPLAY EX:
Day the usage data was previously reset	SINCE APR-19
Number of hours the fryer was on	PWR ON HRS 165
Number of times oil was filtered	FILTERED 34
Total number of cook cycles	TOTAL CK 462
Cook Cycles stopped before "DONE"	TUE* QUIT COOK 4
Percentage of Cook Cycles before oil change	OIL WEAR -A- 73%
Percentage of hours before oil change	OIL WEAR -B- 47%
Cook Cycles for Product #1	COOKED -1- 193
Cook Cycles for Product #2	COOKED -2- 107
Cook Cycles for Product #3	COOKED -3- 58
Cook Cycles for Product #4	COOKED -4- 0
Cook Cycles for Product #5	COOKED -5- 13
Cook Cycles for Product #6	COOKED -6- 69
Cook Cycles for Product #7	COOKED -7- 0
Cook Cycles for Product #8	COOKED -8- 7
Cook Cycles for Product #9	COOKED -9- 15
Cook Cycles for Product #0	COOKED -0- 0
Reset usage data: Enter the Mgr Code (1, 2, 3 unless changed) on this step to zero out all the usage information.	RESET USG/ ENTER CODE---J

Press  to continue to INP A_CVHDSF_M

5. INP A_CVHDSF_M

Press  to view the status of components and inputs. If

the input signal is detected, an identifying letter is displayed (see below). If the signal is not detected, “_” is displayed.

With the COOK/PUMP switch in the COOK position, and all inputs detected, “H_P_ A_CVHDSF_M” shows in the display. See below for “definition” of codes.

A = COOK/PUMP in COOK position.

B = COOK/PUMP in PUMP position

C = Solenoid continuity; won't show with pressure on

V = Volts - 24 VAC detected

H = High Limit - If “H” is present, the high limit is good; if “H” is missing, the high limit is tripped (overheated) or faulty

D = DRAIN SWITCH-If “D” is present, the drain handle is closed; if “D” is missing, the drain is open or faulty

S = COOK/PUMP switch ON interlock circuit: If “S” is present, the COOK/PUMP switch is in the COOK position.

If the “S” is missing, the COOK/PUMP is either off, failed, or wired incorrectly

F = FAN

M = MV-Detects 24 V jumper to MV terminal

3-19. INFORMATION MODE
(Continued)

Press  to view the specific status of each input. An underscore (“_”) indicates the input is not presently detected. A checkmark (“✓”) indicates the signal is detecting a normal input. A blinking (“X”) indicates the signal is presently detected, but is detected as a half-wave (partially failed) input.

NOTICE

The V, H, D, S, F, P and M signals below are wired in series. The first signal missing out of this sequence generally causes all signals to the right of it to be missing as well.

Press  to continue onto OUTP H* P_.

6. OUTP H* P_

This mode displays the status of components and outputs. If the output signal is detected, an identifying letter is displayed (see below), followed by an “*”. If the output is off, “_” is displayed.

“H” = Heat output

“P” = Pressure output

If heat is on, “H*” shows in display. If heat is off, “H_” shows in display. If controls senses a problem with the heat output, “H*” shows in display, with the “*” flashing.

If pressure is on, “P*” shows in display. If pressure is off, “P_” shows in display. If controls senses a problem with the pressure output, “P*” shows in display, with the “*” flashing.

Press  to view the amp “DRAW” status of each output. “H ✓” and “P ✓” in the display means the amps are good. A flashing “X” behind the H or P means too much current.

Press  to view the No Connect/Ground (“NC/GND”) status of each output. This monitors a possible problem with the relays on the output PC board.

“H ✓” and “P ✓” in the display means everything on the output PC board is good. A flashing “X” behind the H or P means a problem exists.

Press  to view the outputs and inputs (see step 10) together.

3-19. INFORMATION MODE
(Continued)

Press  and “6. PMP_ AIR_” shows in display.

Press  to view the amp “DRAW” status of the pump motor output and air valve output. “PMP ✓” and “AIR ✓” in the display means the amps are good. A flashing “X” behind the “PMP” or “AIR” means too much current.

Press  to view the No Connect/Ground (“NC/GND”) status of each output. This monitors a possible problem with the relays on the output PC board.

Press  to continue onto the OIL TMP reading.

7. OIL TMP

This step shows the present peanut oil temperature. The display shows “7. OIL TMP (temp.)”.

Press  to continue onto the CPU TMP reading.

8. CPU TMP

This step shows the present PC board temperature.

Press  to continue onto the ANALOG reading.

9. ANALOG <1> 2.86V

This step displays the present status of any channel of the controller’s a to d converter. This feature may be useful to a technician troubleshooting a problem with the fryer or controller.

The displayed value can be toggled between volts and bits by pressing . If the displayed value has a decimal point, it is voltage (0 to 5 VDC). If no decimal point is shown, the value is a-to-d bits (0 - 4095).

NOTICE

Press and hold  to exit Information Mode at any time, or after 2 minutes, controls automatically exit back to normal operation.

SECTION 4. TROUBLESHOOTING

4-1. TROUBLE SHOOTING GUIDE

Problem	Cause	Correction
Power switch on but fryer completely inoperative	<ul style="list-style-type: none"> • Open circuit 	<ul style="list-style-type: none"> • Fryer plugged in • Check breaker or fuse at wall
Pressure not exhausting at end of Cook Cycle	<ul style="list-style-type: none"> • Solenoid or exhaust line clogged 	<ul style="list-style-type: none"> • Turn off and allow fryer to cool to release the pressure in frypot; have all lines, solenoid and exhaust tank cleaned
Operating pressure too high	<ul style="list-style-type: none"> • Deadweight clogged 	<ul style="list-style-type: none"> • Turn off and allow fryer to cool to release the pressure in frypot; clean deadweight; See Preventive Maintenance Section



DO NOT OPERATE UNIT IF PRESSURE GAUGE SHOWS HIGH PRESSURE CONDITIONS. SEVERE INJURIES AND BURNS WILL RESULT. IMMEDIATELY PLACE THE COOK/PUMP SWITCH IN THE OFF POSITION, WHICH RELEASES THE PRESSURE BY ALLOWING THE UNIT TO COOL. DO NOT RESUME USE OF UNIT UNTIL CAUSE OF HIGH PRESSURE HAS BEEN FOUND AND CORRECTED.

Pressure does not build	<ul style="list-style-type: none"> • Not enough product in frypot • Metal shipping spacer not removed from deadweight • Pressure not programmed • Lid gasket leaking 	<ul style="list-style-type: none"> • Place full capacity product in frypot when using fresh shortening. • Remove shipping spacer; see Unpacking Instructions Section • Check programming • Reverse or replace lid gasket
Shortening not heating	<ul style="list-style-type: none"> • Drain valve open • High temperature limit tripped 	<ul style="list-style-type: none"> • Close drain valve. • Reset high temperature limit; see Operating Components Section
Foaming or boiling over	<ul style="list-style-type: none"> • See Boil-Over chart on fryer and beginning of Operation Section in this manual 	<ul style="list-style-type: none"> • Follow Boil-Over procedures from chart
Shortening not draining	<ul style="list-style-type: none"> • Drain valve clogged 	<ul style="list-style-type: none"> • Push cleaning rod through open drain valve
Filter motor won't run	<ul style="list-style-type: none"> • Motor overheated 	<ul style="list-style-type: none"> • Reset motor; see Filter Pump Motor Protector-Manual Reset Section

NOTICE

More detailed troubleshooting information is available in the Technical Manual, available at www.hennypenny.com, or 1-800-417-8405 or 1-937-456-8405.

4-2. ERROR CODE TABLE

In the event of a control system failure, the digital display shows an error message. These messages are coded: “E4”, “E5”, “E6”, “E10”, “E15”, “E-25”, “E-26”, “E-27”, “E41”, “E46”, “E47”, “E48”, “E70A” & “B” and “E92”. An alarm sounds when an error code is displayed, and to silence this alarm, press any button.

DISPLAY	CAUSE	PANEL BOARD CORRECTION
“E-4”	Control board overheating	Turn switch to OFF position, then turn switch back ON; if display shows “E-4”, the control board is getting too hot; check the louvers on each side of the unit for obstructions; check cooling fan, if present
“E-5”	Shortening overheating	Turn switch to OFF position, then turn switch back to ON; if display shows “E-5”, the heating circuits and temperature probe should be checked
“E-6 A”	Temperature probe open	Turn switch to OFF position, then turn switch back to ON; if display shows “E-6”, have the temperature probe checked
“E-6 B”	Temperature probe shorted	Turn switch to OFF position, then turn switch back to ON; if display shows “E-6” have the temperature probe checked
“E-10”	High limit	Reset the high limit by manually pushing up on the reset button; if high limit does not reset, high limit must be replaced
“E-15”	Drain switch failure	Close drain, using the drain valve handle; if display still shows “E-15”, have the drain microswitch checked
“E-25”	Heat amps too high	Heating elements drawing too much current; have heat circuit checked
“E-26”	Heat amps locked on	Heating elements are drawing current when controls are <u>not</u> calling for heat; have controls and heat circuit checked
“E-27”	Heat amps too low	Heating elements current is lower than expected; have heat circuit checked

4-2. ERROR CODE TABLE
(Continued)

<u>DISPLAY</u>	<u>CAUSE</u>	<u>PANEL BOARD CORRECTION</u>
"E-41", "E-46"	Programming Failure	Turn switch to OFF, then back to ON, if display shows any of the error codes, try to reinitialize the control; if error code persists, have the control board replaced
"E-47"	Analog converter chip or 12 volt supply failure	Turn switch to OFF, then back to ON, if "E-47" persists, have the I/O board, or the PC board replaced; if speaker tones are quiet, probably I/O board failure
"E-48"	Input system error	Have PC board replaced
"E-70 B"	Faulty power switch, or switch wiring; faulty I/O board	Have power switch checked, along with its wiring; have Input/Output board replaced if necessary
"E-92"	24 VAC fuse on I/O board open	Have components, in 24-volt circuit (I.E., hi limit, drain switch)checked for shorts

GLOSSARY
HENNY PENNY PRESSURE FRYERS

air valve	a valve that allows air into the filter lines when the pump is on in the mixing mode on eight head fryers
airflow switch	a switch that senses the amount of airflow coming from the blower; if the airflow falls below a certain level, the switch cuts power to the gas control valve that shuts down the burners on gas eight head fryers
blower	located on the rear of a gas eight head fryer, the blower pulls flue gases out of the flue and provides the proper amount of air to the burner tubes for efficient combustion
breeding	a flour and seasoning mixture used to coat the product prior to frying
burner assembly <i>(gas fryers only)</i>	an assembly on gas fryers that houses the pilot light which ignites the gas that heats the fryer
burner chamber <i>(gas fryers only)</i>	the area on four head fryers in which the gas combustion that heats the shortening takes place
burner tubes <i>(gas fryers only)</i>	the tubes in eight head fryers through which heated air is forced to heat the shortening
carrier	a wire frame inside the eight head frypot that holds five racks of product during the cook cycle
casters	the wheels on bottom of the fryer that allow the unit to roll; casters should be locked when unit is in use and not being moved; casters may be adjusted to help level the fryer
cleaning solution	an agent used to clean the frypot; see recommended cleaning procedures
cold zone	an area in the bottom of the frypot where shortening is cooler than the area above; the zone allows the crumbs to settle without burning
condensation drain pan	a pan located at the bottom of the fryer that collects condensation from the steam exhaust system; the pan should be removed and emptied periodically
cook cycle	a programmed cycle that cooks a particular product at a preselected temperature and for a preselected time
cooking load	the amount of product cooked during a cook cycle
cool	a preset temperature, usually 250° F (121° C) or less, which can be manually or automatically switched to, to save the life of the shortening, when not cooking.
counterweight	the weights shipped with the fryer that, when installed in the counterweight assembly, enable the eight head fryer lid to lift easily

counterweight assembly	an assembly of weights and cables that enable the eight head fryer lid to lift easily
cracklings	the crumbs of breading that come off the product during a cook cycle crumb catcher the part of the filter assembly on four head fryers that filters crumbs out of the shortening before the shortening is pumped back into the frypot
crumb catcher	the part of the filter assembly on four head fryers that filters crumbs out of the shortening before the shortening is pumped back into the frypot
data plate	a label or plate located on the right side panel of the fryer that indicates the fryer type, serial number, warranty date, and other information
deadweight	a metal cylinder that works with the orifice to regulate the amount of steam entering the deadweight assembly
deadweight valve assembly	an assembly that controls pressure inside the frypot; the entire deadweight assembly should be cleaned according to the recommended procedures; the assembly is made up of the deadweight, the deadweight cap, the deadweight orifice, the deadweight valve, and the deadweight body
deadweight cap	a threaded cap that screws onto the deadweight valve housing
deadweight orifice	an opening that regulates the amount of steam entering the deadweight assembly
deadweight body	a container that holds the deadweight assembly
deadweight seat	indentation on both ends of deadweight
dilution box	a metal air intake device on the rear of the fryer to pull in fresh air for the blower
drain interlock switch	a microswitch that automatically shuts off the fryer heat in the event the drain valve is inadvertently opened while the fryer power switch is in the ON position
drain valve	a valve that allows the shortening to drain from the frypot into the filter drain pan; the fryer power switch should be in the OFF position before the drain valve is opened; the drain valve should remain closed at all other times
drop temperature	the starting, preset cooking temperature, at which product is placed in the shortening
dumping table	a table onto which the cooked product is dumped after removal from the fryer frypot
exhaust hose	a hose used to vent steam from the frypot on eight head fryers
fill lines	the lines marked on the interior rear wall of the frypot that show the proper shortening level <i>(also referred to as level indicator lines)</i>
filter clips	the clips are the part of the filter screen assembly that holds the filter envelope closed
filter union	the threaded connection between the fryer and the filter system that can be connected or released without tools

filter drain pan	a pan that rolls or slides under the fryer into which shortening is drained
filter envelope	a fiber envelope into which the filter screen is placed; the end of the envelope is folded and held closed with filter clips; a part of the filter screen assembly
filter quick disconnect	an optional connection on the fryers allowing the filter rinse hose to be connected or released without tools
filter screen assembly	an assembly that filters the shortening as it is pumped from the frypot; the assembly is made up of two filter screens, a filter envelope, and two filter clips <i>(Note: four head fryers have three filter screens that includes a crumb catcher)</i>
flame sensors <i>(gas fryers only)</i>	the sensors that shut off the gas supply to eight head gas fryers if the pilot lights go out or do not light
flashpoint	the temperature at which shortening ignites
frypot	the interior portion of the fryer that holds the shortening and the product while cooking
frypot collar	the top flat surface area around the fryer lid
gas control valve <i>(gas fryers only)</i>	an automatic dual controller that controls gas to both pilot lights and gas pressure to burners on fryers; if either pilot light goes out, the controller shuts off the gas to the other pilot light
gas valve knob <i>(gas fryers only)</i>	the knob that opens and closes the gas control valve
gas pressure regulator <i>(gas fryers only)</i>	a device located on the gas control valve that regulates the gas pressure; the pressure specifications are preset at the factory
heat indicator	the light that illuminates when the shortening is being heated; the light goes off when the preset shortening temperature has been achieved
heating elements	the coils located inside the frypot on electric fryers that heat the shortening
high limit	a temperature control that opens and shuts off the heat to the frypot if it senses shortening temperature in excess of 420°F (212°C) on eight head fryers and 450°F (232°C) on four head fryers
idle	a preset temperature, usually 250° F (121° C) or less, which can be manually or automatically switched to, to save the life of the shortening, when not cooking.
ignition modules	two modules that send electrical energy to the spark igniters that ignite the pilot lights on eight head gas fryers
L-shaped brush	a brush included with the fryer that is used to clean around the burner tubes and heating elements
landing table	another name for a dumping table <i>(see dumping table)</i>
level indicator lines	lines marked on the interior rear wall of the frypot that show the proper shortening level <i>(also referred to as fill lines)</i>

lid assembly	an assembly comprised of lid, lid handle, lid latch, and lid gasket <i>(Note: on four head fryers. the lid assembly includes spindles)</i>
lid gasket	the gasket around the lid that creates a seal when the lid is properly latched
lid handle	a handle that is attached to the lid and is used to lower the lid into contact with the frypot; the handle is then pulled forward and pushed down to lock the lid in place <i>(see lid latch)</i>
lid latch	a mechanical catch on the front of the fryer lid that engages a bracket located on the front of the frypot; the latch holds the lid down while it is being locked into place
manual shutoff valve <i>(gas fryers only)</i>	a valve located between the fryer and the wall that shuts off the flow of gas from the supply line; this is not the main shutoff valve for the store
P-H-T	the automatic control of pressure, heat, and time to produce appealing food product
pilot orifice <i>(gas fryers only)</i>	a controlled opening for the pilot light located on the burner assembly
pilot light <i>(gas fryers only)</i>	a small flame that remains burning even when the fryer is not in use; the flame ignites the gas when the fryer is turned on
poker brush	a brush that is included with the fryer that is used to clear the drain in the bottom of the frypot. <i>(also referred to as straight brush)</i>
power/pump switch	a three-way switch located on the front control panel of the fryer that serves as an off/on switch and a filter switch
pressure gauge	the gauge located on the left rear corner of the frypot that shows the pressure inside the frypot
pressure pad	a piece of plastic on eight head fryers located between the lid locking arm and the lid casting that helps create the seal for the lid; only a service technician should perform maintenance or repair on the pressure pad
product	a food item cooked in the fryer
ready	the starting, preset cooking temperature, at which product is placed in the shortening
safety relief valve	a spring loaded valve that automatically releases excess pressure if the operating valve becomes obstructed; if the safety release valve activates, turn the Power/Pump switch to "OFF" to release all pressure from the frypot
setpoint	a preset cooking temperature; the setpoint is a programmable feature
shipping spacer	a spacer located in the deadweight assembly for protection during shipment
shortening mixing system	an automatic system on eight head fryers that periodically uses the filter pump to mix the shortening in the frypot to prevent an accumulation of moisture to minimize the boiling action in the frypot

sift breading	the process of removing clumps from breading
solenoid valve	a valve used to generate or release pressure for the cook cycle
spark igniters (<i>gas fryers only</i>)	the igniters that create a spark to ignite the pilot lights on eight head gas fryers (<i>see ignition modules</i>)
standpipe	the pipe through which oil is pumped back into the frypot after the filtering process is complete
standpipe assembly	the pipe and fittings that are part of the shortening filtering process
straight brush	a brush that is included with the fryer that is used to clear the drain in the bottom of the frypot
temperature probe	a round probe that is located in the inside of the frypot that measures the temperature of the oil in the frypot; the probe communicates with the control panel



**Henny Penny Corporation
P.O.Box 60
Eaton, OH 45320**

**1-937-456-8400
1-937-456-8402 Fax**

**Toll free in USA
1-800-417-8417
1-800-417-8434 Fax**

www.hennypenny.com