



**SERVICE  
MANUAL**

# 4-Head Gas Pressure Fryers



**MODEL 600**

FM06-009D



# Table of Contents

Safety and Compliance .....	ix
Chapter 1 Troubleshooting.....	1
1.1 Introduction .....	1
1.2 Diagnostics.....	1
Chapter 2 Maintenance .....	13
2.1 Introduction .....	13
2.2 Maintenance Hints .....	13
2.3 Preventative Maintenance Schedule.....	13
2.4 Lower the Control.....	14
2.4.1 Raise the Control .....	14
2.4.2 Replace the Control .....	14
2.4.3 Configure the Serial Number.....	15
2.4.3.1 Verify the Serial Number .....	15
2.4.3.2 Adding or Correcting a 9 Character Serial Number.....	16
2.4.3.3 Adding or Correcting a 7 Character Serial Number.....	17
2.5 Transformer Replacement .....	17
2.6 Temperature Probe Replacement.....	18
2.7 Temperature Regulation (Single Stage) .....	20
2.7.1 Front Panel Thermostat.....	20
2.7.2 Internal Operation .....	20
2.7.3 Drain Microswitch .....	21
2.7.4 High Limit Temperature Control.....	21
2.8 Calibrating The Standard Single Stage Thermostat.....	21
2.9 Testing The Thermostat.....	21
2.9.1 Procedure .....	21
2.10 Thermostat Replacement.....	22
2.11 High Temperature Limit Control .....	25
2.11.1 Description .....	25
2.11.2 Checkout.....	26
2.11.3 Replacement .....	26
2.12 Gas Burner Assembly.....	28
2.12.1 Description .....	28
2.12.2 Safety Precautions.....	29
2.12.3 Replacement .....	29
2.13 Thermocouple.....	31
2.13.1 Description .....	31
2.13.2 Safety Precautions.....	32
2.13.3 Replacement .....	32
2.14 Gas Control Valve .....	33
2.14.1 Description .....	33
2.14.2 Safety Precautions.....	33
2.14.3 Operator Replacement .....	33
2.14.4 Regulator Spring Replacement .....	35
2.14.5 Adjusting Pilot Burner.....	35
2.14.6 Adjusting Regulator.....	36

2.15	Electrical Components.....	37
2.15.1	Fan.....	38
2.15.2	Drain Switch.....	38
2.15.2.1	Gas Models.....	38
2.15.3	Main Power Switch.....	39
2.15.4	Continuity Check Procedure.....	40
2.15.5	Replacement.....	40
2.15.6	Indicator Lights.....	41
2.15.7	Fuse Holder.....	41
2.15.8	Checking Procedure For Fuses.....	41
2.15.9	Cord & Plug Check.....	41
2.15.10	Wall Receptacle (Voltage Check).....	41
2.15.10.1	Gas Models.....	41
2.16	Timing Control.....	42
2.16.1	Description.....	42
2.16.2	Checking Procedure.....	42
2.16.3	Replacement.....	43
2.16.4	Timer Light.....	44
2.16.5	Buzzer Coil.....	44
2.16.6	Timer Switch.....	45
2.17	Pressure Regulation/Exhaust.....	45
2.17.1	Solenoid Valve.....	45
2.17.2	Coil Check Procedure.....	45
2.17.3	Replacement.....	46
2.17.4	Deadweight Valve.....	51
2.17.5	Cleaning Steps.....	51
2.17.6	Removal & Cleaning of Safety Relief Valve.....	52
2.17.7	Pressure Gauge.....	52
2.17.7.1	Calibration Steps.....	52
2.17.7.2	Cleaning Steps.....	53
2.17.8	Condensation Box Assembly.....	53
2.17.9	Condensation Box Bottom Removal.....	54
2.17.10	Lid Cover Assembly.....	55
2.17.10.1	Description.....	55
2.17.10.2	Lid Cover Removal.....	55
2.17.10.3	Lid Cover Installation.....	56
2.17.11	Lid Hinge Spring.....	56
2.17.12	Latch Spring Installation.....	57
2.17.13	Lid Liner.....	60
2.17.14	Reversing The Lid Gasket.....	60
2.17.14.1	Purpose.....	60
2.17.14.2	Process.....	61
2.17.15	Lid Limit Stop Adjustment.....	62
2.17.16	Spindle Screw Assembly.....	63
2.18	Filtering System.....	68
2.18.1	Filter Rinse Hose.....	68
2.18.2	Removal.....	69
2.18.3	Installation.....	69
2.18.4	Filter Valve Description.....	69
2.18.5	Removal.....	70
2.18.6	Filter Pump Repair.....	70
2.18.7	Cover Removal.....	70

2.18.8	Pump Removal .....	71
2.18.9	Filter Pump Motor Protector - Manual Reset .....	73
2.19	Gas Conversion .....	73
2.19.1	Service Hints .....	73
2.19.2	Maintenance .....	74
2.20	Wiring Diagrams .....	75
2.21	Caster Replacement Procedure .....	75
2.22	Solenoid Valve .....	75
2.22.1	Replace Solenoid Valve Assembly .....	76
Chapter 3	Parts Information .....	79
3.1	Introduction .....	79
3.2	Genuine Parts .....	79
3.3	How To Find Parts .....	79
3.4	Sub-Assemblies .....	80
3.5	How To Order Parts .....	81
3.6	Prices .....	81
3.7	Delivery .....	82
3.8	Warranty .....	82
3.9	Recommended Spare Parts For Distributors .....	82
3.10	Parts and Illustrations .....	83
Chapter 4	C8000 Replacement Parts .....	175
4.1	Controls and Decals .....	175
4.2	600 Series Gas Control Valve .....	177
4.3	600 Series Gas Components .....	178
4.4	Rear Panel Wiring Connection Decal .....	180
4.5	600 230v 50/60Hz. 1PH .....	181
4.6	600 208-240v 50/60Hz. 1PH .....	182
4.7	600 120v 50/60Hz. 1PH .....	183
4.8	600 120v 50/60Hz. 1PH .....	184
4.9	600 208-240v 50/60Hz. 1PH .....	185
Chapter 5	Pressure Assist Features and Function .....	187
5.1	Software .....	187
5.1.1	C8000 Controller .....	187
Chapter 6	Programming .....	189
Chapter 7	Wiring Diagrams .....	197
7.1	600 GF, 120v, 60Hz, 1P, STD IGN (63240H) .....	197
7.2	600 GF, 240v, 50Hz, 1P, SI (55318A) .....	198
7.3	600 GF, 120v, 60Hz, 1P, EI (34389C) .....	199
7.4	600 GF, 120-240v, 50/60Hz, 1P, STD IGN (63694L) (Before AN0702112) .....	200
7.5	600 GF, 120-240v, 50/60Hz, 1P, ESI (75555B) (AN0703021-11029-Shaw) .....	201
7.6	600 GF, 120-240v, 50/60Hz, 1P, ESI (75555E) (After AN0703021-Fenwal) .....	202
7.7	600 GF, 120v, 50/60Hz, 1P, ESI (67152C) (After AN0703021 use 75555) .....	203
7.8	600 GF, 208-240v, 50/60Hz, 1P, ESI (69076C) (After AN0703021 use 75555) .....	204
7.9	600 GF, 230v, 50Hz, 1P (34807K) (Before AN0702112) .....	205
7.10	600 GF, 230v, 50Hz, 1P, SSI (75556B) (AN0703021-711029-Shaw) .....	206
7.11	600 GF, 230v, 50Hz, 1P, SSI (75556D) (After AN0711030-Fenwal) .....	207
7.12	600 GF, C1000 & 2000, 100/120v, 50/60Hz, 1P, 24v, SSI (78558D) .....	208
7.13	600 GF, C1000 & 2000, 230v, 50Hz, 1P, 24v, 24v SSI (80221B) .....	209
7.14	600 EF, LVC, 120v, 50/60Hz, 1P (68598B) .....	210

7.15	600 C/C EF, 120v, 50/60Hz, 1P, Wendy's FPS, ESI (67199G) (AN0703021-711029-Shaw).....	211
7.16	600 C/C EF, 120v, 50/60Hz, 1P, ESI (67199J) (After AN0711030-Fenwal) .....	212
7.17	600 C/C EF, 208-240v, 50/60Hz, 1P (32759G).....	213
7.18	600 C/C EF, 208-240v, 50/60Hz, 1P, ESI (67204E) .....	214
7.19	600 C/C EF, LVC, 208-240v, 50/60Hz, 1P (68614B).....	215
7.20	600 C/C EF, LVC, 230v, 50/60Hz, 1P (68615B).....	216
7.21	600 GF, 100-240v 50/60 Hz, 1P (63357N) (Before AN0702112).....	217
7.22	600 GF, 100-240v 50/60 Hz, 1P, SSI (75510C) (AN0703021-0711029-Shaw).....	218
7.23	600 GF, 100-240v, 50/60Hz, 1P, SSI (75510) (After AN0711030-Fenwal).....	219
7.24	600 EF, 230v, 50/60Hz, 1P (63358N) (Before AN0702112).....	220
7.25	600 EF, 230v, 50/60Hz, 1P, SSI (75511C) (AN0703021-0711029-Shaw).....	221
7.26	600 EF, 230v, 50/60Hz, 1P, SSI (75511F) (After AN0711030-Fenwal).....	222
7.27	600 EF, 120v, 50/60Hz, 1P (23457F) (After AN0703021 use 75510).....	223
7.28	600 SC GF, 120v, 60Hz, 1P, Dual Thermostat (17353F) .....	224
7.29	600 SMS EF, 100-240v, 50/60Hz, 1P, SMS, SSI (75190D).....	225
7.30	600 SMS EF, 230v, 50Hz, 1P, SMS, SSI (75512B) (AN0703021-711029-Shaw).....	226
7.31	600 SMS EF, 230v, 50Hz, 1P, SMS, SSI (75512F) (After AN0711030-Fenwal).....	227
Chapter 8	Annual Inspection.....	229
8.1	Henny Penny Start-Up Provider Information.....	229
8.2	Store Information .....	229
8.3	Equipment Information .....	229
8.4	Signatures.....	229
8.5	Checklist .....	229
8.6	Inspect the Fry Pot .....	234
8.7	Inspect the Casters and Frame .....	235
8.8	Inspect the Power Cord .....	235
8.9	Inspect the Gas Hose and Connection .....	236
8.10	Inspect the Flue .....	236
8.11	Inspect the Condensation Box .....	237
8.12	Inspect the Solenoid and Deadweight Plumbing .....	238
8.12.1	Clean the Dead Weight Plumbing.....	238
8.12.2	Clean the Solenoid Plumbing .....	239
8.13	Inspect the Drain Switch .....	240
8.14	Test the Filtration System.....	240
8.15	Inspect the Drain Pan .....	241
8.16	Inspect the High Limit .....	241
8.17	Inspect the Temperature Probe .....	242
8.18	Inspect the Burner.....	243
8.18.1	Clean the Burner Jets.....	243
8.18.2	Clean the Pilot Assembly .....	244
8.19	Inspect for Oil Leaks.....	245
8.19.1	Plumbing Leaks in Filtration .....	245
8.19.2	Plumbing Leaks During Cooking .....	246
8.20	Test Pressure Regulator .....	246
8.21	Inspect Deadweight.....	247
8.22	Inspect Latch, Catch and Spring.....	248
8.23	Inspect Cross Arm Component.....	250
8.24	Lubricate Cross Arm Components .....	253

8.25	Pressure Regulation and Exhaust System.....	254
8.25.1	Clean the Lid Liner .....	254
8.25.2	Reverse the Lid Gasket .....	255
8.25.3	Adjust the Lid Limit Stop .....	255
8.25.4	Removal and Cleaning of Safety Relief Valve .....	256
8.25.5	Pressure Gauge Calibration.....	257
8.25.6	Coil Check Procedure.....	258
8.25.7	Locking Pin Test Procedure .....	258

# List of Tables

Table 1-1 Troubleshooting .....	1
Table 2-1 Preventative Maintenance Schedule .....	13
Table 2-2 Gas Control Valve Check Procedures .....	34
Table 2-3 Continuity Check Procedure - Off Position .....	40
Table 2-4 Continuity Check Procedure - Power Position .....	40
Table 2-5 Continuity Check Procedure - Pump Position .....	40
Table 2-6 Checking Procedure - ON/OFF Switch .....	42
Table 2-7 Checking Procedure - Buzzer Coil .....	43
Table 2-8 Checking Procedure - Microswitch .....	43
Table 2-9 Checking Procedure - Motor .....	43
Table 2-10 Checking Procedure - Reset Coil .....	43
Table 2-11 Coil Check Procedure .....	46
Table 3-1 KFC SMS-20 Controls & Spare Parts .....	87
Table 3-2 Fast Control Panel .....	95
Table 3-3 Hybrid Control Panel .....	96
Table 3-4 Filter Screen Kits .....	144
Table 3-5 Table 1 .....	167
Table 3-6 Table 2 .....	167
Table 6-1 Programming .....	189

# List of Figures



Figure 2-1 Thermostat Test Points .....	22
Figure 2-2 Thermostat Sensing Bulb - Gas .....	22
Figure 2-3 Thermostat & Control Panel Diagram .....	23
Figure 2-4 Screw Nut Assembly .....	24
Figure 2-5 High Limit Reset Button - Gas .....	25
Figure 2-6 High Limit Capillary Tube - Gas .....	27
Figure 2-7 Gas Burner Assembly .....	28
Figure 2-8 Gas Supply Connection .....	30
Figure 2-9 Heat Shield Deflector Assembly .....	30
Figure 2-10 Pilot & Thermocouple Assembly .....	32
Figure 2-11 Gas Control Valve .....	33
Figure 2-12 Regulator Spring Replacement .....	35
Figure 2-13 Pilot Burner .....	35
Figure 2-14 Pressure Tap .....	36
Figure 2-15 Adjusting Regulator .....	37
Figure 2-16 Continuity Check Test Points .....	40
Figure 2-17 Solenoid Valve Assembly .....	46
Figure 2-18 Exhaust Fitting .....	49
Figure 2-19 Conduit Fitting .....	50
Figure 2-20 Solenoid Valve Diagram .....	50

Figure 2-21 Latch Spring Assembly .....	58
Figure 2-22 Lid Cover Screws .....	61
Figure 3-1 Computron C1000 Control .....	83
Figure 3-2 Wendy's Computron C2000 Control .....	85
Figure 3-3 KFC SMS-20 Control .....	87
Figure 3-4 Fast Control Panel.....	89
Figure 3-5 Standard Control Panel.....	92
Figure 3-6 Automatic Reset Timer Assembly .....	97
Figure 3-7 CFA Original Panel .....	98
Figure 3-8 Electric Conduit Assembly.....	100
Figure 3-9 Frame & Cabinet Assembly.....	103
Figure 3-10 Lid Components .....	107
Figure 3-11 Complete Lid w/ Crossbar Assembly (with Language Specific Labels) .....	110
Figure 3-12 Fry Basket .....	112
Figure 3-13 3 Tier Wire Basket .....	114
Figure 3-14 CFA Half-Quarter Size Funnels.....	116
Figure 3-15 CFA Double Hinged Basket.....	117
Figure 3-16 Exhaust Stack Assembly.....	118
Figure 3-17 Deadweight Valve Assembly .....	122
Figure 3-18 Solenoid Valve Assembly .....	124
Figure 3-19 Drain Valve Assembly .....	127
Figure 3-20 Lower Filter Plumbing Components.....	129
Figure 3-21 Upper Filter Plumbing Components.....	133
Figure 3-22 Rinse Hose .....	136
Figure 3-23 Filter Motor & Pump.....	137
Figure 3-24 Direct-Connect Assembly - Model 600.....	139
Figure 3-25 Filter Drain Pan & Filter Screen Assembly .....	141
Figure 3-26 Supersorb Filter Assembly (Before 3-1-02).....	145
Figure 3-27 Supersorb Filter Assembly (3-1-02 & After) .....	148
Figure 3-28 Contactor & Frame Assembly (Single Phase Electric Model).....	150
Figure 3-29 Contactor & Frame Assembly (Three Phase Electric Model) .....	152
Figure 3-30 Fan & High Temperature Limit Control.....	154
Figure 3-31 Electronic Ignition Assembly.....	156
Figure 3-32 Vat (frypot) & Gas Burner Assy - Non-CE, Domestic, & Electric Ignition.....	158
Figure 3-33 Gas Line & Burner Assembly - CE, International, & Electronic Ignition .....	161
Figure 3-34 Gas Control Valve.....	165
Figure 3-35 Countertop Insulation Assembly (Gas Model) .....	168
Figure 3-36 Firebox & Flue Assembly (Gas Model) .....	170
Figure 3-37 Firebox Insulation Assembly (Gas Model).....	172
Figure 8-1 PFG 600 Weld Locations .....	234



# Safety and Compliance

Henny Penny fryers have many safety features incorporated. However, the only way to ensure safe operation is to fully understand the proper installation, operation, and maintenance procedures. The instructions in this manual have been prepared to aid you in learning the proper procedures. Where information is of particular importance or is safety related, the words DANGER, WARNING, CAUTION, or NOTICE are used. Their usage is described as follows:

 <b>DANGER</b>	<b>DANGER!</b> indicates hazardous situation which, if not avoided, will result in death or serious injury.
<b>DANGER!</b>	
 <b>WARNING</b>	<b>WARNING!</b> indicates hazardous situation which, if not avoided, could result in death or serious injury.
<b>WARNING!</b>	
 <b>CAUTION</b>	<b>CAUTION!</b> indicates hazardous situation which, if not avoided, could result in moderate or minor injury.
<b>CAUTION!</b>	
<i>NOTICE</i>	<i>NOTICE</i> is used for information considered important regarding property damage.

These are the original version controlled Henny Penny instructions for Pressure Fryer Gas (PFG) model 600 (PFG 600).

This manual is available on the Henny Penny Public website ([www.hennypenny.com](http://www.hennypenny.com)). Read these instructions completely prior to installation and operation of this appliance to ensure compliance to all required installation, operation and safety standards. Read and obey all safety messages to avoid damage to the appliance and personal injury.



## **WARNING**

- **This fryer must be installed and used in a way that water does not contact the oil which can cause splashing and boiling over of oil and steam leading to personal injury; excludes normal product moisture.**
- **Burn risk! Do not move the fryer or filter drain pan while containing hot oil. Personal injury or serious burns can result from splashing hot oil.**

This appliance is intended for commercial use in kitchens of restaurants, bakeries, hospitals, etc. but not for the continuous mass production of food such as in a factory setting. During use the units airborne A-weighted emission sound pressure is below 70 db(A). All repairs must be performed by the manufacturer, its service agent or similarly qualified persons in order to avoid a hazard.

Always use strain relief. The provided power cord must be installed with a strain relief in a way that if the strain relief fails, wires L1, L2, L3 and N must draw taunt and fail first. If the supplied power cord or an existing one becomes damaged, do not use it; rather, replace it with a known good power cord. The power cord must be replaced by the manufacturer, its service agent or similarly qualified persons in order to avoid a hazard.

Proper daily, weekly, monthly, quarterly and yearly maintenance must be performed on this appliance to ensure safe and continuous operation. This appliance must never be cleaned with a water jet or steam cleaning tool. Cleaning brushes are shipped with the appliance and proper cleaning instructions are included in this manual.

Proper maintenance also increases the usable life of the appliance and oil, which reduces lifetime operating costs. Additionally, old oil increases the possibility of surge boiling and fire due to the reduced flash point of the oil. The oil temperature must never exceed 450° F (230° C).

This appliance is not intended for use by persons (including children) with reduced physical, sensory or mental capabilities, or lack of experience and knowledge, unless they have been given supervision or instruction concerning use of the appliance by a

person responsible for their safety. Children should be supervised to ensure that they do not play with the appliance.

This appliance is not intended to be operated by means of an external timer or a separate remote control system.

This appliance must be installed in accordance with the manufacturer's instructions and the regulations in force and only used in suitably ventilated location. Read the instructions fully before installing or using the appliance.

This appliance must be installed with suitable ventilation in accordance with the manufacturer's instructions and the regulations in force to prevent the occurrence of unacceptable concentrations of substances harmful to health. Proper air flow is essential to permit efficient removal of the steam exhaust and frying odors. Air flow for this model is 33.3 cfm (56.6 m<sup>3</sup>/h) of air flow.

For gas appliance installations in South Africa, the installation shall be carried out by a registered installer, and the installation shall comply with requirements of SANS 10087-1 or SANS827 as applicable.

**WASTE ELECTRICAL AND ELECTRONIC EQUIPMENT (WEEE)** As of August 16, 2005, the Waste Electrical and Electronic Equipment directive went into effect for the European Union. Our products have been evaluated to the WEEE directive. We have also reviewed our products to determine if they comply with the Restriction of Hazardous Substances directive (RoHS) and have redesigned our products as needed in order to comply. To continue compliance with these directives, this unit must not be disposed as unsorted municipal waste. For proper disposal, please contact your nearest Henny Penny distributor.

#### Technical Data For CE Marker Products

Nominal Heat Input (Net):	Natural (I <sub>2H</sub> ) = 21.1 kW (72,000 Btu/h)
	Natural (I <sub>2E</sub> ) = 21.1 kW (72,000 Btu/h)
	Natural (I <sub>2E+</sub> ) = 21.1 kW (72,000 Btu/h)
	Natural (I <sub>2L</sub> ) = 21.1 kW (85,000 Btu/h)
	Natural (I <sub>2(43.46-45.3 MJ/m<sup>3</sup>(0°C))</sub> ) = 21.1 kW (72,000 Btu/h)
	Liquid Propane (I <sub>3P</sub> ) = 21.1 kW (72,000 Btu/h)

## Technical Data For CE Marker Products

Nominal Heat Input (Gross):	Natural (I <sub>2H</sub> ) = 23.4 kW (80,000 Btu/h)
	Natural (I <sub>2E</sub> ) = 23.4 kW (80,000 Btu/h)
	Natural (I <sub>2E+</sub> ) = 23.4 kW (80,000 Btu/h)
	Natural (I <sub>2L</sub> ) = 23.4 kW (80,000 Btu/h)
	Liquid Propane (I <sub>3P</sub> ) = 22.9 kW (78,000 Btu/h)
Supply Pressure:	Natural (I <sub>2H</sub> ) = 20 mbar (2.0 kPa)
	Natural (I <sub>2E</sub> ) = 20 mbar
	Natural (I <sub>2E+</sub> ) = 20/25 mbar
	Natural (I <sub>2L</sub> ) = 25 mbar
	Liquid Propane (I <sub>3P</sub> ) = 30 mbar
	Liquid Propane (I <sub>3P</sub> ) = 37 mbar
	Liquid Propane (I <sub>3P</sub> ) = 50 mbar
Test Point Pressure:	Natural (I <sub>2H</sub> ) = 8.7 mbar (0.87 kPa)
	Natural (I <sub>2E</sub> ) = 8.7 mbar
	Natural (I <sub>2E+</sub> ) = 8.7/10 mbar
	Natural (I <sub>2L</sub> ) = 10 mbar
	Liquid Propane (I <sub>3P</sub> ) = 25 mbar
Injector Size:	Natural (I <sub>2H</sub> ) = 1.04 mm
	Natural (I <sub>2E</sub> ) = 1.04 mm
	Natural (I <sub>2E+</sub> ) = 1.04 mm
	Natural (I <sub>2L</sub> ) = 1.04 mm
	Liquid Propane (I <sub>3P</sub> ) = 0.66 mm
Restrictor Size:	Natural (I <sub>2E+</sub> ) = 4.1 mm

# Chapter 1 Troubleshooting

## 1.1 Introduction

This section provides troubleshooting information in the form of an easy to read table. If a problem occurs during the first operation of a new fryer, recheck the installation per Section 2 Unpacking/Installation of the Operator's Manual. Before troubleshooting, always recheck the operating procedure per Section 3 Operating Instructions of the Operator's Manual.

## 1.2 Diagnostics

To isolate a malfunction, proceed as follows:

1. Clearly define the problem (or symptom) and when it occurs.
2. Locate the problem in the troubleshooting table.
3. Review all possible causes. Then, one-at-a-time, work through the list of corrections until the problem is solved.

**WARNING!** Refer to the maintenance procedures in [Chapter 2 Maintenance, page 13](#). If maintenance procedures are not followed correctly injuries and/or property damage can result.

Table 1-1 Troubleshooting

Problem	Cause	Correction
<b>Cooking Section</b>		
Product Color Not Correct:		
A. Too dark.	Temperature too high.	<ul style="list-style-type: none"><li>• Reduce thermostat setting.</li><li>• Remove and replace defective thermostat per <a href="#">2.10 Thermostat Replacement, page 22</a>.</li></ul>
	Shortening too old.	Change shortening.
	Shortening too dark.	<ul style="list-style-type: none"><li>• Filter shortening.</li><li>• Shortening taste test, see the Operator's Manual.</li><li>• Change Shortening.</li></ul>

Problem	Cause	Correction
	Dip solution too strong for product.	Use correct dip solution or shorten product immersion time.
	Breading product too far in advance.	Bread product closer to actual frying period.
B. Too light.	Temperature too low.	<ul style="list-style-type: none"> <li>• Increase temperature.</li> <li>• Remove and replace defective thermostat per <a href="#">2.10 Thermostat Replacement, page 22</a>.</li> </ul>
	Dip solution too weak for product.	Correct dip solution.
	Incorrect preheat procedures.	<ul style="list-style-type: none"> <li>• Allow proper preheat time.</li> <li>• Stir shortening prior to dropping product into vat (frypot).</li> </ul>
	Vat (frypot) overloaded with product.	Reduce cooking load.
	Slow fryer heat-up/recovery.	Refer to burner or heating elements in <a href="#">Chapter 2 Maintenance, page 13</a> .
C. Product greasy.	Shortening old.	Replace shortening.
	Temperature too low.	<ul style="list-style-type: none"> <li>• Increase thermostat settings.</li> <li>• Temperature not recovered when product was dropped in vat (frypot) basket.</li> <li>• Replace thermostat if needed.</li> </ul>
	Vat (frypot) overloaded.	Reduce cooking load.
	Product not removed from vat (frypot) immediately after depressurization.	Remove product immediately after depressurization of the vat (frypot).
D. Spotted product.	Improper separation of the product.	Refer to Operator's Manual.

<b>Problem</b>	<b>Cause</b>	<b>Correction</b>
	Product was incorrectly dipped in water before breading.	Agitate product during the dipping procedure.
	Breading not uniform on product.	<ul style="list-style-type: none"> <li>• Sift breading during breading.</li> <li>• Refer to Operator's Manual.</li> </ul>
	Burned breading particles on product.	Filter the shortening more frequently.
	Product sticking together.	Separate product prior to pressure cooking, see the Operator's Manual.
E. Dryness of product.	Moisture loss prior to cooking.	<ul style="list-style-type: none"> <li>• Use fresh products.</li> <li>• Keep product covered with a moist cloth to reduce evaporation.</li> </ul>
	Over cooking the product.	<ul style="list-style-type: none"> <li>• Reduce cooking time.</li> <li>• Reduce cooking temperature.</li> </ul>
	Low operating pressure.	Check pressure gauge reading; check for pressure leaks.
	Product load too small.	Increase quantity to obtain correct operating pressure and product quality.
Product Flavor (Taste):		
A. Salty taste.	Breading mixture is too salty.	<ul style="list-style-type: none"> <li>• Sift breading after each use.</li> <li>• Incorrect breading mixture.</li> <li>• Discard old breading.</li> </ul>
	Marination mixture too concentrated.	Reduce the concentration of the marination mixture.
	Incorrect choice of breading.	Use breading designed for the desired product.
B. Burned taste.	Burned shortening flavor.	Replace shortening.

Problem	Cause	Correction
	Shortening needs filtering.	Filter shortening more frequently.
	Vat (frypot) not properly cleaned.	Drain and clean vat (frypot).
C. Bland taste.	Raw product not fresh.	Use fresh raw products.
	Breading mixture incorrect for product (spice content too low).	Use breading designed for desired product.
	Cooking temperature too high (spice flavor lost).	Use correct temperature for breading used.
	Breading does not adhere to product.	Use correct dip and breading, and use correct procedure for the product.
D. Rancid taste.	Shortening too old.	Replace shortening, and follow recommended care and use of shortening, see the Operator's Manual.
	Non-compatible products cooked within the same shortening.	<ul style="list-style-type: none"> <li>• Replace shortening.</li> <li>• Use compatible products, and follow recommended care and use of shortening; refer to Operator's Manual.</li> </ul>
	Infrequent filtering.	Replace shortening and follow recommended care and use of shortening; refer to Operator's Manual.
	Raw product not fresh.	Use fresh product.
General:		
A. Meat separation from bone.	Incorrect meat cut.	Use correct meat cutting procedures.
	Overcooking.	Reduce cooking time.
	Raw product contains too much water.	Allow product to drain after marinating.
	Product not fresh.	Use fresh product.
B. Bone color not proper.	Using frozen product (black bone).	Use fresh product.

Problem	Cause	Correction
	Improper handling of product (black bone).	Use proper handling procedures for product.
	Product not thoroughly cooked (red bone).	Increase cooking time.
C. Breading falls off.	Incorrect breading procedures.	Use correct breading procedure, see the Operator's Manual.
	Product partially frozen during breading.	Thoroughly thaw the product before breading.
	Improper handling of cooked product.	Handle cooked product carefully.
	Excessive stirring of product prior to closing the lid.	Separate the product, see the Operator's Manual.
D. Product sticking together.	Product breaded too long prior to cooking.	Refer to breading & frying instructions.
	Improper separation procedures prior to closing the lid.	Separate the product, see the Operator's Manual.
	Vat (frypot) overloaded with product.	Reduce the cooking load.
	Improper loading procedure.	Load product properly into vat (frypot), see the Operator's Manual.
<b>Power Section</b>		
With switch in POWER position, the fryer is completely inoperative (NO POWER).	Open circuit.	<ul style="list-style-type: none"> <li>• Check to see that unit is plugged in.</li> <li>• Check breaker or fuse at supply box.</li> <li>• Check control panel fuses per <a href="#">2.15 Electrical Components, page 37</a> section (electric module only).</li> <li>• Check voltage at wall receptacle.</li> <li>• Check MAIN POWER switch per <a href="#">2.15 Electrical Components, page 37</a>; replace if defective.</li> </ul>

Problem	Cause	Correction
		<ul style="list-style-type: none"> <li>• Check cord and plug per <a href="#">2.15 Electrical Components, page 37</a>.</li> <li>• Check circuit breaker on single phase fryers.</li> </ul>
Pressure Section		
Pressure will not exhaust at end of cook cycle.	Exhaust line from solenoid valve to expansion tank clogged.	Release pressure from vat (frypot); clean all pressure lines, exhaust stacks, and expansion tank on gas model.
	Solenoid valve clogged.	Check and clean solenoid valve per <a href="#">2.17 Pressure Regulation/Exhaust, page 45</a> .
Operating pressure too high.	Deadweight clogged.	Place proper quantity of moist product within vat (frypot) to generate steam.
	Exhaust line to stack clogged.	Clean exhaust line to stack.
Pressure does not build.	Not enough product in fryer or product not moist.	Place proper quantity of moist product within vat (frypot) to generate steam.
	Metal shipping spacer not removed from deadweight.	Remove shipping spacer per Operator's Manual.
	Lid open or not latched.	Close and latch lid.
	Solenoid valve leaking or not closing.	Check and clean solenoid valve per <a href="#">2.17 Pressure Regulation/Exhaust, page 45</a> .
	Deadweight valve leaking.	Repair per <a href="#">2.17 Pressure Regulation/Exhaust, page 45</a> .
	Main timer not closing solenoid.	Check main timer per <a href="#">2.16 Timing Control, page 42</a> .
	Lid gasket leaking.	Adjust lid limit stop; if this does not correct the problem, reverse the lid gasket; if this fails to correct the problem, replace the lid gasket.

Problem	Cause	Correction
	Safety relief valve leaking.	Check and replace, if necessary, per <a href="#">2.17 Pressure Regulation/Exhaust</a> , page 45.
<b>Filter System Section</b>		
Filter motor runs but pumps shortening slowly.	Filter valve not open.	Open filter valve.
	Pump clogged.	Remove and clean pump per <a href="#">2.18 Filtering System</a> , page 68.
	Filter frame not properly assembled.	Handles must put pressure on filter.
	Filter line connections loose.	Tighten all filter line connections.
	Solidified shortening in lines.	Clear all filter lines of solidified shortening.
	Charcoal filter clogged (if applicable).	Change charcoal filter (if applicable).
Pump switch ON, motor does not run.	Defective switch.	Check/replace switch per <a href="#">2.15 Electrical Components</a> , page 37.
	Defective motor.	Check/replace motor per <a href="#">2.18 Filtering System</a> , page 68.
	Motor thermal protector tripped.	Reset thermal switch per <a href="#">2.18 Filtering System</a> , page 68.
Motor hums but will not pump.	Clogged lines or pump.	<ul style="list-style-type: none"> <li>Remove and clean pump and lines per <a href="#">2.18 Filtering System</a>, page 68.</li> <li>Replace pump seal, rotor and rollers per <a href="#">2.18 Filtering System</a>, page 68.</li> </ul>
<b>Heating of Shortening Section</b>		
Shortening will not heat.	Blown fuse or tripped circuit breaker at supply box or control panel.	Reset breaker or replace fuse.
	Blown fuse at control panel.	Check fuse per <a href="#">2.15 Electrical Components</a> , page 37.

Problem	Cause	Correction
	Faulty main switch.	Check main switch per <a href="#">2.15 Electrical Components, page 37</a> .
	No power.	Check cord and plug and power at wall receptacle per <a href="#">2.15 Electrical Components, page 37</a> .
	High limit control switch open.	Press red high limit reset per <a href="#">2.11 High Temperature Limit Control, page 25</a> .
	Faulty thermostat.	Check thermostat per <a href="#">2.10 Thermostat Replacement, page 22</a> .
	Faulty high limit control switch.	Check high limit control switch per <a href="#">2.11 High Temperature Limit Control, page 25</a> .
Heating of shortening too slow.	Low or improper voltage.	Use a meter and check the receptacle against data plate.
	Wire(s) loose.	Tighten.
	Burnt or charred wire connection.	Replace wire and clean connectors.
Shortening overheating.	Check thermostat.	Check faulty thermostat per <a href="#">2.10 Thermostat Replacement, page 22</a> .
Pilot will not light.	Pilot not lit.	Light pilot per Section 2-10 Gas Pilot Lighting & Burner Lighting and Shutdown Procedure of Operator's manual.
	Plugged pilot orifice, and/or pilot supply tube.	Unplug pilot orifice and/or pilot supply tube.
	Gas supply off.	Turn ON gas supply.
	Faulty gas control valve.	Replace gas control valve.
	Air in gas supply line.	Bleed air from supply line.
Pilot will not stay lit.	Faulty thermocouple.	Replace thermocouple per <a href="#">2.13 Thermocouple, page 31</a> .
	Pilot magnetic plug.	Replace gas control valve per <a href="#">2.14 Gas Control Valve, page 33</a> .

<b>Problem</b>	<b>Cause</b>	<b>Correction</b>
Burner will not light, pilot lit (gas model)	Drain valve open.	Close drain valve.
	High limit control switch.	Press red high limit reset per <a href="#">2.11 High Temperature Limit Control, page 25</a> .
	Faulty high limit control switch.	With power removed from fryer, check across high limit switch terminals with ohmmeter; replace if no reading is indicated on meter.
	Possible faulty gas control valve.	With power removed from fryer, check across electrical leads of gas control valve with ohmmeter, and gas control valve in ON position; Ohm reading should be 350 ohms resistance; replace the control valve if not within 10%.
	Possible faulty thermostat.	Check thermostat per <a href="#">2.10 Thermostat Replacement, page 22</a> ; replace thermostat if found to be faulty.
Heating of Shortening Too Slow (gas model).	Supply line too small - low gas volume.	Increase supply line size, see Section 2 Unpacking/Installation of Operator's manual.
	Incorrect jet size.	Replace with proper size jet for type of gas, and altitude (contact factory).
	Improper ventilation system.	Refer to Section 2-5 Ventilation of Fryer in Operator's Manual.
Shortening overheating (gas model).	Possible faulty thermostat.	Check thermostat per <a href="#">2.10 Thermostat Replacement, page 22</a> ; replace thermostat if found to be faulty.
<b>Shortening Foaming/Draining</b>		
Foaming or boiling over of shortening (gas/electric models).	Water in shortening.	At end of cook cycle, drain shortening and clean vat (frypot), add fresh shortening, and check procedure for raising lid.
	Condensation line stopped up.	Condensation line stopped up.

Problem	Cause	Correction
	Improper or bad shortening.	Use recommended shortening.
	Improper filtering.	Refer to the procedure covering filtering the shortening.
	Improper rinsing after cleaning the fryer.	Clean and neutralize the vat (frypot); rinse with vinegar to remove alkaline then rinse with hot water, and dry vat (frypot).
Shortening will not drain from vat (frypot).	Drain valve clogged with crumbs.	Open valve - force cleaning brush through drain opening.
	Drain valve will not open by turning handle.	Replace cotter pins in valve coupling.
<b>Main Timer Section</b>		
Timer fails to run.	No power input.	<ul style="list-style-type: none"> <li>• Check timer switch.</li> <li>• Check timer motor.</li> </ul>
Buzzer continues to buzz.	Timer set at zero.	Set timer indicator to a setting other than zero.
	Faulty microswitch.	Check and replace faulty microswitch per <a href="#">2.15 Electrical Components, page 37</a> .
Buzzer will not buzz.	Possible faulty buzzer.	Check buzzer per <a href="#">2.16 Timing Control, page 42</a> .
	Timer indicator not returning to zero.	Replace timer per <a href="#">2.16 Timing Control, page 42</a> .
Timer will not reset.	Faulty timer.	Replace timer.
Timer light out.	Faulty lamp.	Replace lamp per <a href="#">2.16 Timing Control, page 42</a> .
<b>Lid Section</b>		
Gasket coming out of lid liner.	Crumbs under gasket.	<ul style="list-style-type: none"> <li>• Remove gasket and clean per <a href="#">2.17 Pressure Regulation/Exhaust, page 45</a>.</li> <li>• Clean top rim of vat (frypot).</li> </ul>

Problem	Cause	Correction
		<ul style="list-style-type: none"> <li>Replace worn or damaged gasket per <a href="#">2.17 Pressure Regulation/Exhaust, page 45.</a></li> </ul>
Lid spindle will not turn or turns hard with lid open.	Spindle dry.	Lubricate spindle per <a href="#">2.17 Pressure Regulation/Exhaust, page 45.</a>
	Worn acme nut.	Replace acme nut per <a href="#">2.17 Pressure Regulation/Exhaust, page 45.</a>
Lid will not unlatch from closed position.	Lid gasket not seated properly or idle nut not adjusted.	<p>To check the problem, perform the following procedures:</p> <ol style="list-style-type: none"> <li>Remove pressure from vat (frypot).</li> <li>Turn main switch to off position.</li> <li>Drain shortening from vat (frypot). <b>WARNING! The next procedure must be performed while holding the lid closed until the lid latch is free from the cross-arm. failure to hold down the lid will result in the lid springing back to a full open position. personal injury, or damage to the hinge may result.</b></li> <li>Remove Tru-Arc ring. Drive latch pin out. Lid will open.</li> <li>Raise lid slowly.</li> <li>Reinstall latch.</li> <li>Adjust limit stop, per <a href="#">2.17 Pressure Regulation/Exhaust, page 45.</a></li> <li>Lid gasket should be properly seated in lid liner.</li> </ol>



# Chapter 2 Maintenance

## 2.1 Introduction

This section provides procedures for the checkout and replacement of the various parts used within the fryer. Before replacing any parts, see [Chapter 1 Troubleshooting, page 1](#). It will aid you in determining the cause of the malfunction.

## 2.2 Maintenance Hints

- You may use two test instruments to check electric components:
  - A continuity light
  - An ohmmeter
- When the manual refers to the circuit being closed, the continuity light will be illuminated or the ohmmeter should read zero unless otherwise noted.
- When the manual refers to the circuit being open, the continuity light will not be illuminated or the ohmmeter will read 1 (one).

**NOTICE:** A continuity tester cannot be used to check coils or motors.

## 2.3 Preventative Maintenance Schedule

To ensure a long life of the fryers and their components, regular maintenance should be performed, see the chart below.

Table 2-1 Preventative Maintenance Schedule

Frequency	Action
Daily (3-4 loads)	Filter shortening.
Daily	Clean deadweight valve cap, weight, and orifice.
30 Days	Lubricate spindle threads and ball seat.
90 Days	Reverse lid gasket.
90 Days	Check limit stop adjustment.
90 Days	Check and tighten element spreader bars.
Once A Year	Annual preventative maintenance, see Appendix A.

## 2.4 Lower the Control



### WARNING

To avoid electrical shock or property damage, move the power switch to off and disconnect main circuit breaker, or unplug cord at wall receptacle.

To replace parts inside the fryer, lower the control by doing the following:

- 1) Place the main power switch to the off position. The switch is labeled POWER/OFF/PUMP.
- 2) Remove the two screws from the bottom of the control.



10170023

- 3) Carefully slide the control upward until it lifts off the metal hangers.
- 4) With the fryer door closed, place the lower edge of the control in the slot between the door and the frame of the fryer.

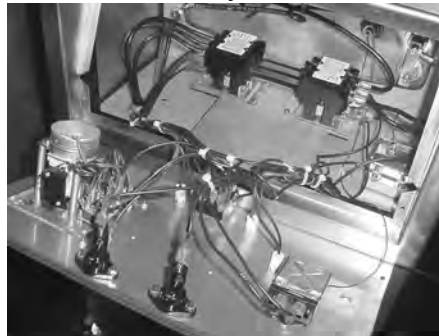

### 2.4.1 Raise the Control

- 1) Raise the control, and then hook it on the metal hangers that hold the top of the control in place.
- 2) Install the two screws in the bottom of the control.
- 3) Reconnect power to the fryer.

### 2.4.2 Replace the Control

Follow the steps outlined in [2.4 Lower the Control, page 14](#) and [2.4.1 Raise the Control, page 14](#).

- 1) Note the locations of the connectors on the back of the control
- 2) Remove the connectors, and then swap out the old control for the new.

- 3) Reconnect the connectors on the back of the control.

### 2.4.3 Configure the Serial Number

**NOTICE:** The serial number must be added correctly in to the control or the WiFi module cannot receive or transmit data, including automated software updates.

#### 2.4.3.1 Verify the Serial Number



- 1) Set the power switch to the OFF position.
- 2) Locate the machine data plate on the inside of the filter pan door, and then record the serial number displayed on it.

**NOTE:** Serial numbers may be one of two formats:

- AAXXXXXXX (AA followed by seven digits)
- BCXXDE (Two letters followed by three digits followed by two more letters)

The serial number may also be etched in to the rear top left corner of the pot (see image below).



- 3) Press and hold   for 7-8 seconds until L-2 LEVEL 2 displays. CFA PROG / ENTER CODE displays.



- 4) Press   twice. SETUP / ENTER CODE displays.

- 5) Using the left product buttons, press 1,2,3. - SETUP MODE - briefly displays.

- 6) Compare the serial number displayed in SM-1 with the number you recorded.

- 7) Perform one of the two actions:

•

If the serial number matches, press and hold   until - OFF - displays. The control resumes normal operation.



•

If the serial number is missing or does not match, follow either the 9 or 7 character serial number correction procedure.

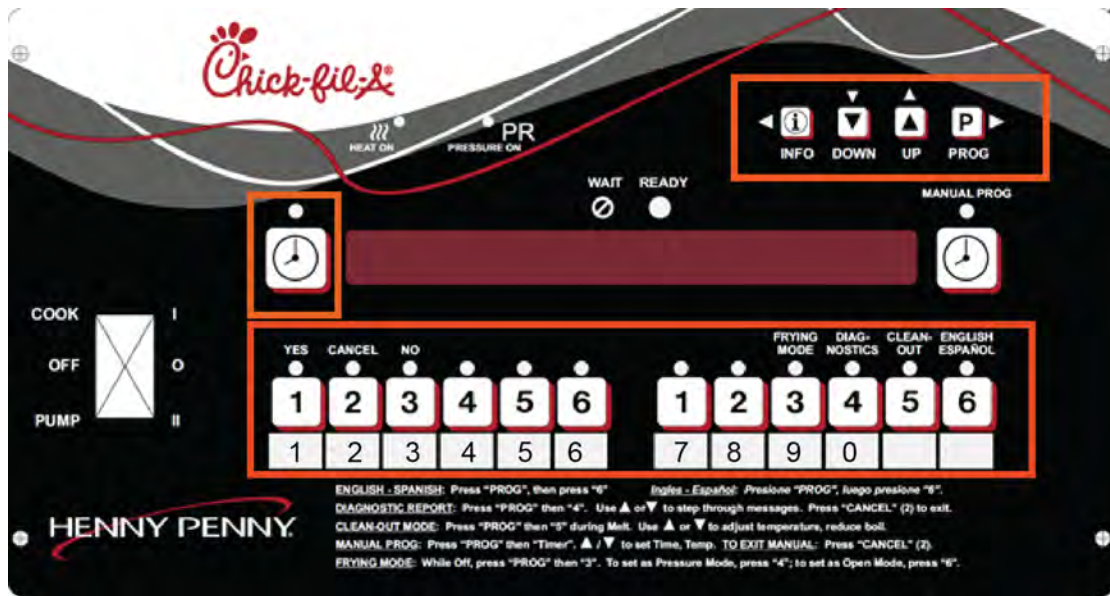



### 2.4.3.2 Adding or Correcting a 9 Character Serial Number











**NOTE:** You only need to enter the first four and last three digits; the “AA” is already populated.

- 1) Press the left-side  button.
- 2) Press the right-side  for standard (STD).
- 3) Press the product keys to enter the first four digits of the serial number you recorded.

**NOTE:** The value of each product key is represented by the number below the product key (see above image).

- 4) Press  to continue.
- 5) Press the product keys to enter the last three digits of the serial number recorded in [2.4.3.1 Verify the Serial Number, page 15](#).
- 6) Press  . SAVE ? YES NO displays.
- 7) Do one of the following:
  - If the serial number is correct, press the right-side  for YES.
  - If the serial number is incorrect, press the right-side  for NO, and then repeat steps 2-6 of this procedure.
- 8) Press and hold  until - OFF - displays. The control resumes normal operation.



### 2.4.3.3 Adding or Correcting a 7 Character Serial Number

- 1) Press the left-side  button.
- 2) Press the  on the right side for custom (CUST). EDIT, and then the current serial number display.
- 3) Press either  once. The ,  and  LEDs flash rapidly.
- 4) Press either  to find the letters and digits corresponding to the serial number recorded in [2.4.3.1 Verify the Serial Number, page 15](#).
- 5) Once you have the correct letter or digit displayed, press . To go back to a previous letter or digit, press .

**NOTE:** If ,  and  LEDs stop flashing, restart at step 2.

- 6) After entering the 7th character of the serial number, press  to find the underscore ( ) which acts as a space character. Enter the space character in the last two places.

**EXAMPLE:** If your serial number is IB018JC, after entering all nine characters, "IB018JC " displays. There are two trailing spaces after the serial number.

- 7) Press  until SM-1 and the serial number you entered displays.
- 8) Press and hold  until - OFF - displays. The control resumes normal operation.

## 2.5 Transformer Replacement

**WARNING!** To avoid electrical shock or property damage, move the power switch to off and disconnect main circuit breaker, or unplug cord at wall receptacle.

The transformer reduces the voltage down to accommodate those components with low voltage.

1. Remove electrical power supplied to the fryer.
2. Remove the control panel. See [2.4 Lower the Control, page 14](#).
3. Disconnect the white box connector.

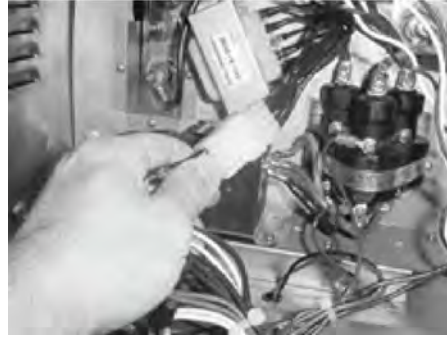

4. Remove the two screws securing transformer to the unit and remove transformer.
5. Replace with new transformer in reverse order.



## 2.6 Temperature Probe Replacement

### **WARNING!**

To avoid electrical shock or property damage, move the power switch to off and disconnect main circuit breaker, or unplug cord at wall receptacle.

The temperature probe relays the actual shortening temperature to the control. If it becomes disabled, "E-6" shows in the display. Also, if the temperature is out of calibration more than 10° F, or 10° C, the temperature probe should be replaced. An Ohm check can be performed also, see [8.17 Inspect the Temperature Probe, page 242](#).

1. Remove electrical power supplied to the fryer.
2. Drain the shortening from the vat (frypot).
3. Remove the control panel. See [2.4 Lower the Control, page 14.](#)
4. Using a 1/2" wrench, remove the nut on the compression fitting.
5. Remove the temperature probe from the vat (frypot).
6. Follow the appropriate instructions below depending upon the type of fryer, gas or electric.

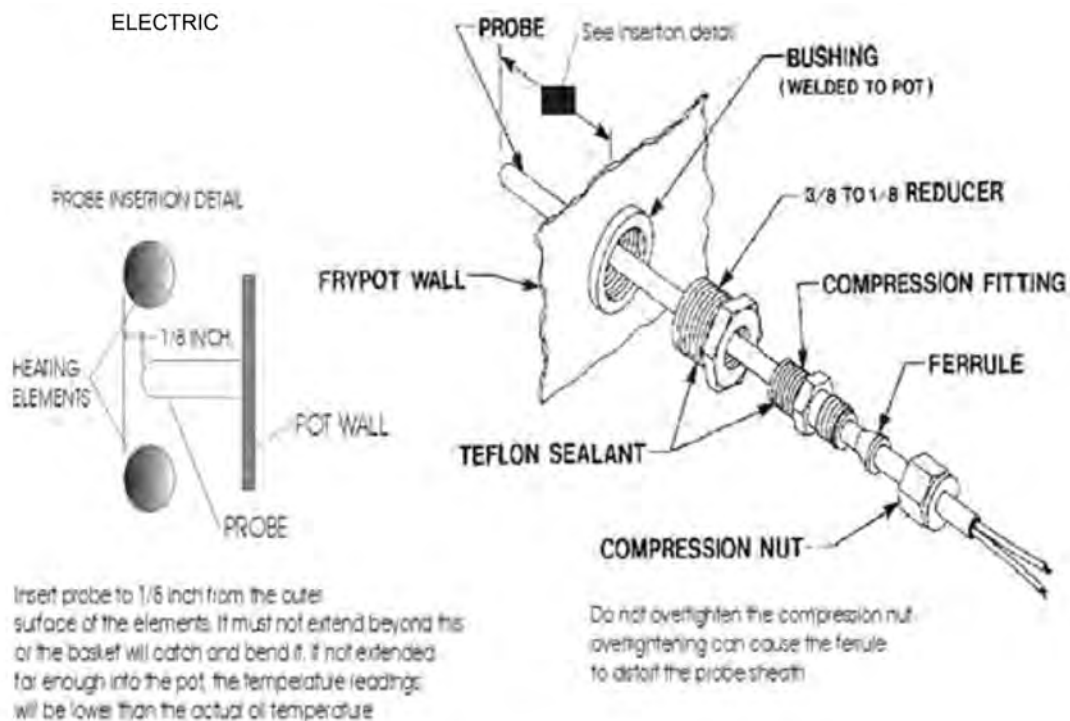

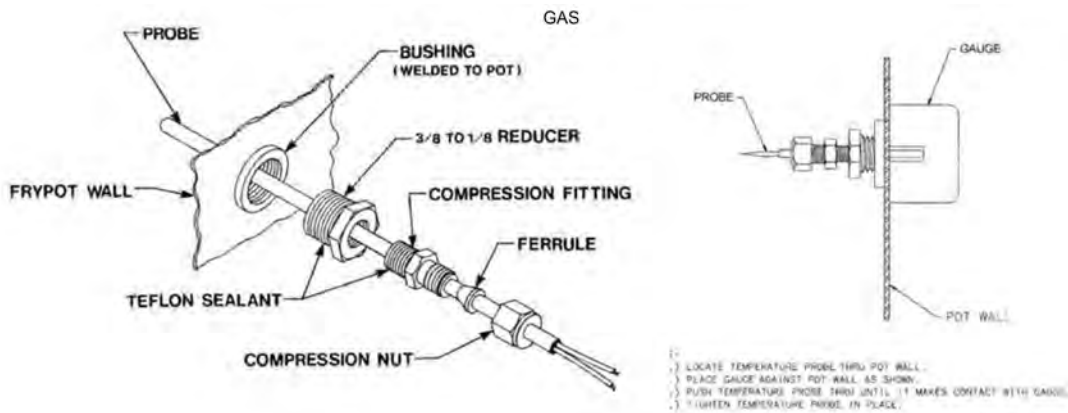

7. Tighten the compression nut hand tight and then a half turn with wrench.
8. Connect new temperature probe to PC board and replace control panel.
9. Replace shortening and turn power on and check out fryer.

## 2.7 Temperature Regulation (Single Stage)

### 2.7.1 Front Panel Thermostat

The cooking temperature is controlled by the front panel thermostat and monitored by its sensing bulb mounted just inside the vat (frypot). Various thermostats are available, but all work on the same principle.

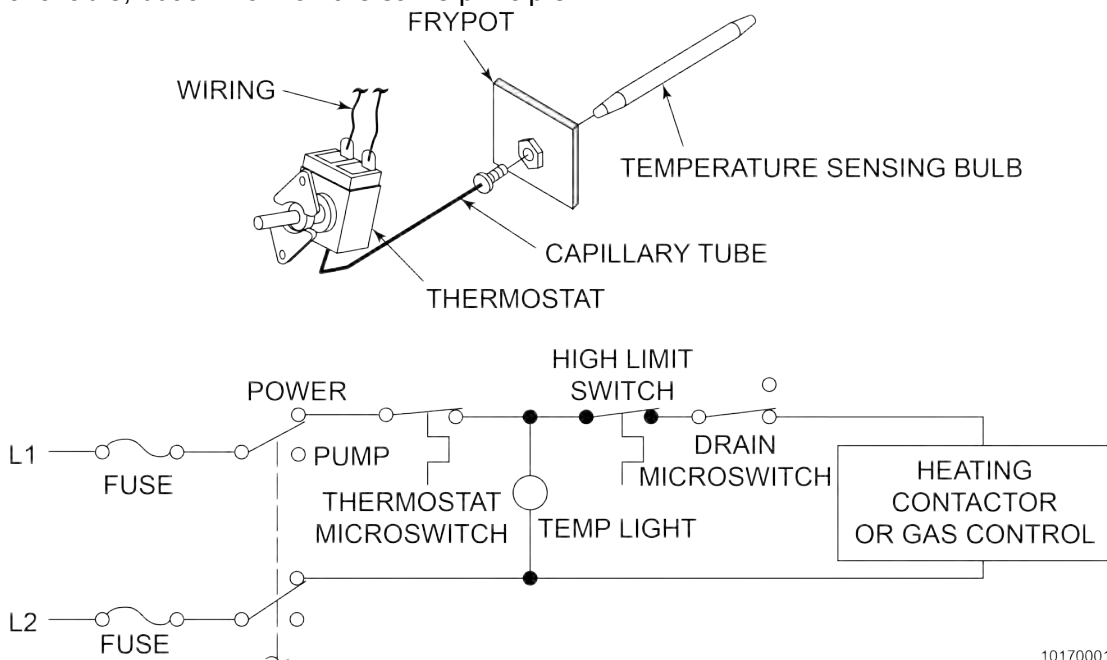

10170001

### 2.7.2 Internal Operation

The thermostat bulb is connected to the thermostat by a thin capillary tube. When the temperature rises, the fluid inside the bulb expands (as in a thermometer) and pushes

fluid through the tube into the control panel thermostat. When the vat (frypot) temperature is lower than the thermostat setting, the TEMP light is illuminated and vat (frypot) is being heated. When the temperature setting is reached, a switch inside the thermostat opens the circuit to the heat source and turns off the TEMP light. When the vat (frypot) starts to cool, the switch closes the circuit to the heat source.

### 2.7.3 Drain Microswitch

This interlock provides protection for the vat (frypot) in the event an operator inadvertently drains the shortening with the switch in the power position. The heat will automatically shut off when the drain valve is opened.

### 2.7.4 High Limit Temperature Control

The high limit temperature provides the safety feature of interrupting the heat if the temperature ever exceeds the safe operating limits. On electric models it must be manually reset when the vat (frypot) cools, see [2.11 High Temperature Limit Control, page 25](#) for maintenance of the high limit temperature control.

## 2.8 Calibrating The Standard Single Stage Thermostat

Henny Penny does not recommend that a field calibration be performed on the thermostats mentioned above. The reasons for this are as follows:

- The thermostat is calibrated in a controlled environment from the factory. The thermostat manufacturers do not recommend any adjustments to the thermostat in the field, as this will affect the factory calibration.
- The difference between a hand-held thermometer and an installed thermostat can be quite large due to shortening temperature variation.
- The adjustment of a thermostat is not precise, since the dial reads only in 25°F increments. The accuracy of a thermostat needs to be less than 5°F.

If a thermostat is not reading accurately and suspected to be faulty, Henny Penny suggests that the thermostat be replaced. If you have any questions, please do not hesitate to call the Technical Services Department.

## 2.9 Testing The Thermostat



### WARNING

To avoid electrical shock or property damage, move the power switch to off and disconnect main circuit breaker, or unplug cord at wall receptacle.

### 2.9.1 Procedure

If the thermostat fails to work properly, perform the following checks before replacing the thermostat:

- 1) Remove electrical power supplied to the fryer.
- 2) Remove the control panel.

- 3) With an ohmmeter or continuity light, check for continuity as follows.
- 4) On a standard single temperature thermostat (Henny Penny Part No. 14293), check between terminals 52 and 53. Move the temperature knob from off to maximum.

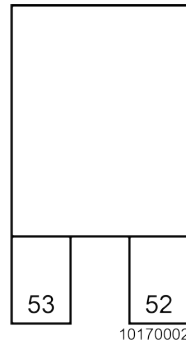

**Figure 2-1 Thermostat Test Points**

- At off position, the circuit should be open.
- At maximum, the circuit should be closed.

## 2.10 Thermostat Replacement



**WARNING**

To avoid electrical shock or property damage, move the power switch to off and disconnect main circuit breaker, or unplug cord at wall receptacle.

- 1) Remove electrical power supplied to the fryer.
- 2) Drain the shortening from the vat (frypot).
- 3) Remove the thermostat sensing bulb from the bulb holder inside the fryer.



**Figure 2-2 Thermostat Sensing Bulb - Gas**

- 4) Place your thumb at the bend in the capillary tube, where it comes into the vat (frypot), and straighten the bulb. The bulb should be extending out into the vat (frypot).
- 5) Remove the two screws which secure the control panel to the frame of the fryer.
- 6) Lift the panel up and off the metal flanges.

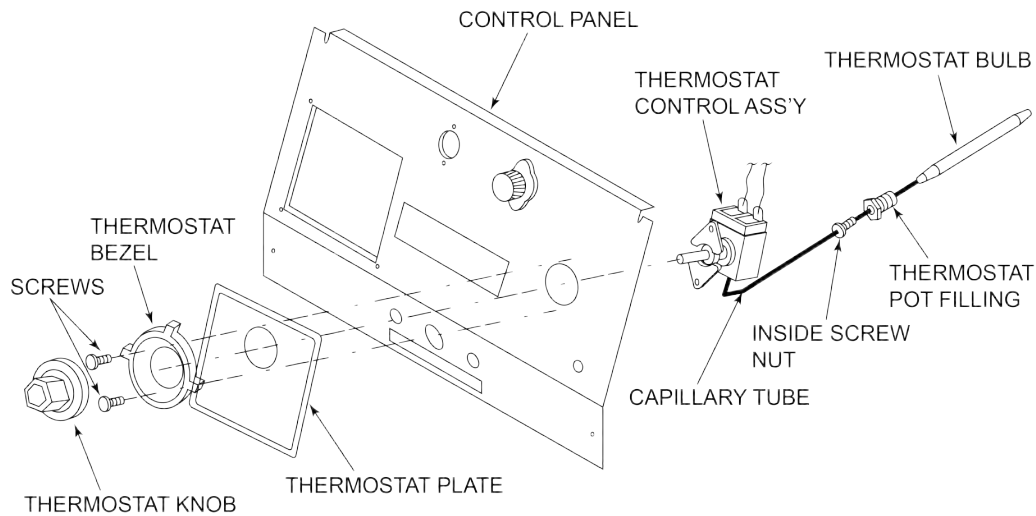

06170011

**Figure 2-3 Thermostat & Control Panel Diagram**

- 7) With the door of the fryer closed, put the bottom edge of the control panel in the slot between the door and the frame of the fryer.
- 8) Locate the thermostat on the back of the panel.
- 9) Remove the thermostat on the back of the panel.
- 10) Remove the thermostat knob on the front of the control panel.
- 11) Remove the small inside screw nut (2) which holds the capillary line, see [Figure 2-4 Screw Nut Assembly, page 24](#).

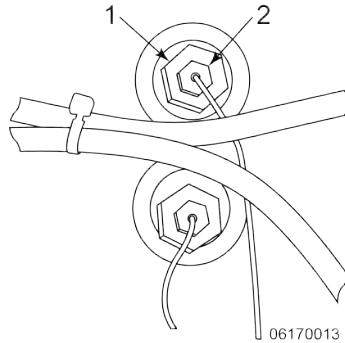

**Figure 2-4 Screw Nut Assembly**

- 12) Remove the large screw nut (1).
- 13) Label the wire connections to the thermostat for correct identification when the new thermostat is installed.
- 14) Disconnect the wires.
- 15) Remove the defective thermostat.
- 16) Install the new thermostat.
- 17) Connect the wires to the new thermostat.

**CAUTION!** Be careful not to cross the wires or thermostat will not operate properly.

- 18) Uncoil the capillary tube.
- 19) Insert the bulb through the wall of the vat (frypot).

**WARNING!** To avoid electrical shock or other injury, the capillary line must run under and away from all electrical power wires. The tube must never be in contact with the electrical power wires or terminals.

- 20) Install the thermostat pot fitting into the wall of the vat (frypot) and tighten.
- 21) Replace the thermostat sensing bulb into the mounting bracket.

**CAUTION!** Do not bend the capillary tube where it connects to the sensing bulb or damage to capillary will result.

- 22) Pull the excess capillary tube from the inside of the vat (frypot).
- 23) Insert and tighten the inside screw nut into the thermostat.
- 24) Install the two screws on the front of the control panel, which secure the thermostat to the back of the panel. Install the thermostat bezel.

- 25) Install the thermostat knob.
- 26) Secure the control panel with the 4 screws.
- 27) Reconnect power to the fryer.
- 28) Calibrate the thermostat [2.8 Calibrating The Standard Single Stage Thermostat](#), page 21.

## 2.11 High Temperature Limit Control

### 2.11.1 Description

This high temperature control is a manual reset control which senses the temperature of the shortening. If the shortening temperature exceeds the safe operating limit, this control switch will open and shut off the heat to the vat (frypot). When the temperature of the shortening drops to the safe operating limit, the control must manually be reset.

To locate the high limit reset button (1), open the door to the drain pan. Look up under the controls and to the right of the filter handle for a red reset button. On the left for single phase units.

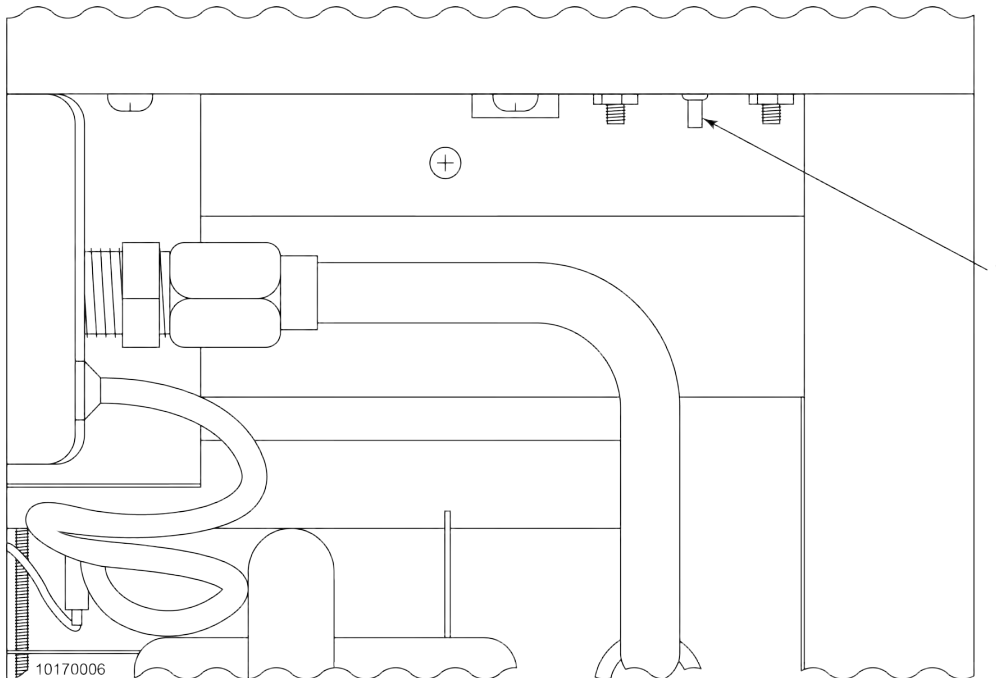

**Figure 2-5 High Limit Reset Button - Gas**

## 2.11.2 Checkout



### WARNING

To avoid electrical shock or property damage, move the power switch to off and disconnect main circuit breaker, or unplug cord at wall receptacle.

### NOTICE:

The shortening temperature must be below 380° F to accurately perform this check.

Before replacing a high temperature limit control, check to see that its circuit is closed.

- 1) Remove electrical power supplied to the fryer.
- 2) Remove the control panel and insert it in the slot above the door, see [2.4 Lower the Control, page 14](#).
- 3) Remove the two electrical wires from the high temperature limit control.

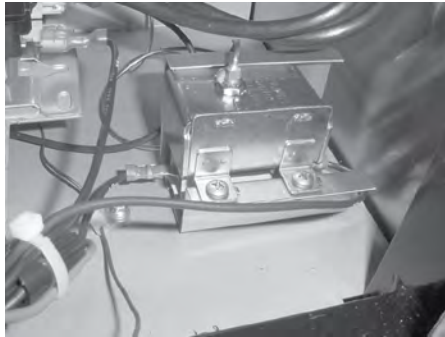

- 4) Check for continuity between the two terminals after resetting the control. If the circuit is open, replace the control, then continue with this procedure. If the circuit is closed, the high limit is not defective. Reconnect the two electrical wires.

## 2.11.3 Replacement



### WARNING

To avoid electrical shock or property damage, move the power switch to off and disconnect main circuit breaker, or unplug cord at wall receptacle.

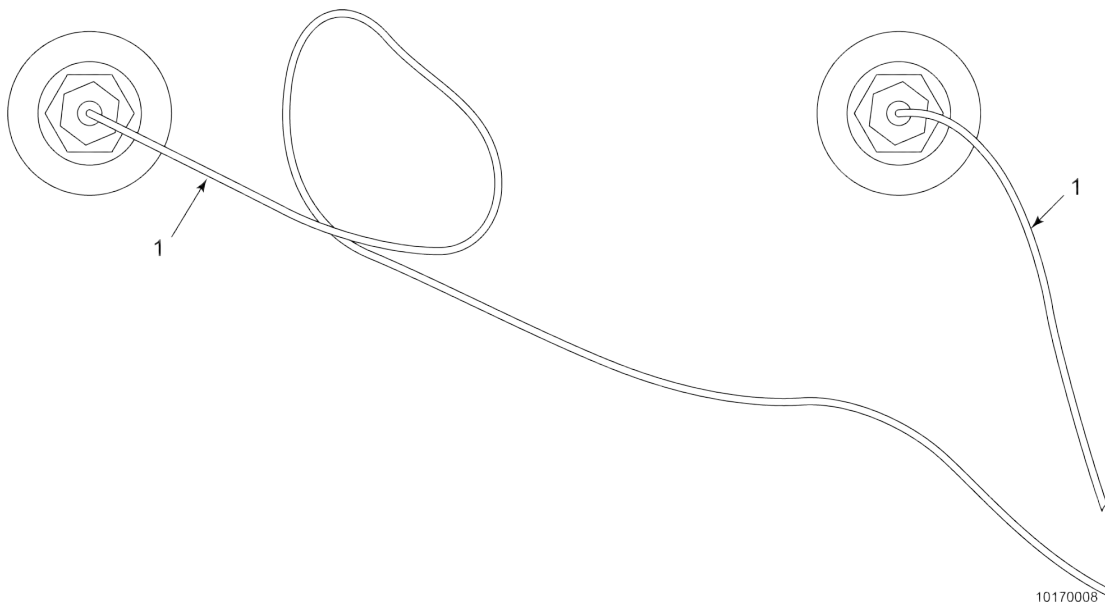

**Figure 2-6 High Limit Capillary Tube - Gas**

- 1) If the capillary tube (1) is broken or cracked, the control will open, shutting off electrical power. The control cannot be reset.
- 2) Drain shortening from the vat (frypot).
- 3) Remove control panel.
- 4) Loosen small inside screw nut on capillary tube.
- 5) Remove capillary bulb from bulb holder inside the vat (frypot).
- 6) Straighten the capillary tube.
- 7) Remove larger outside nut that threads into pot wall.
- 8) Remove the two screws that secure the high limit to the high limit bracket.
- 9) Remove defective control from control panel area.
- 10) Insert new control and replace screws.
- 11) Uncoil capillary line, starting at capillary tube, and insert through vat (frypot) wall.

**WARNING!**

**To avoid electrical shock or other injury, the capillary line must run under and away from all electrical power wires. The tube must never be in contact with the electrical power wires or terminals.**

- 12) Carefully bend the capillary bulb and tube toward the welded clips.

- 13) Slip the capillary bulb into the bulb holder and snap the bulb in the welding clips. Pull excess capillary line from pot and tighten nut into vat (frypot) wall, see [Figure 2-2 Thermostat Sensing Bulb - Gas, page 22](#) for proper installation.

**CAUTION!**

Be sure capillary bulb of high limit is located behind capillary bulb of thermostat. Both capillary bulbs and bulb holders should be positioned as not to interfere with basket or when cleaning the vat (frypot) wall, or damage to capillary tube could result.

- 14) With excess capillary line pulled out, tighten smaller nut.
- 15) Replace front panel.
- 16) Refill with shortening.

## 2.12 Gas Burner Assembly

### 2.12.1 Description

The gas model fryer has a gas burner assembly consisting of a burner casting (9), orifices (8), thermocouple (3), pilot holder (6), and main gas control valve (1), see [Figure 2-7 Gas Burner Assembly, page 28](#).

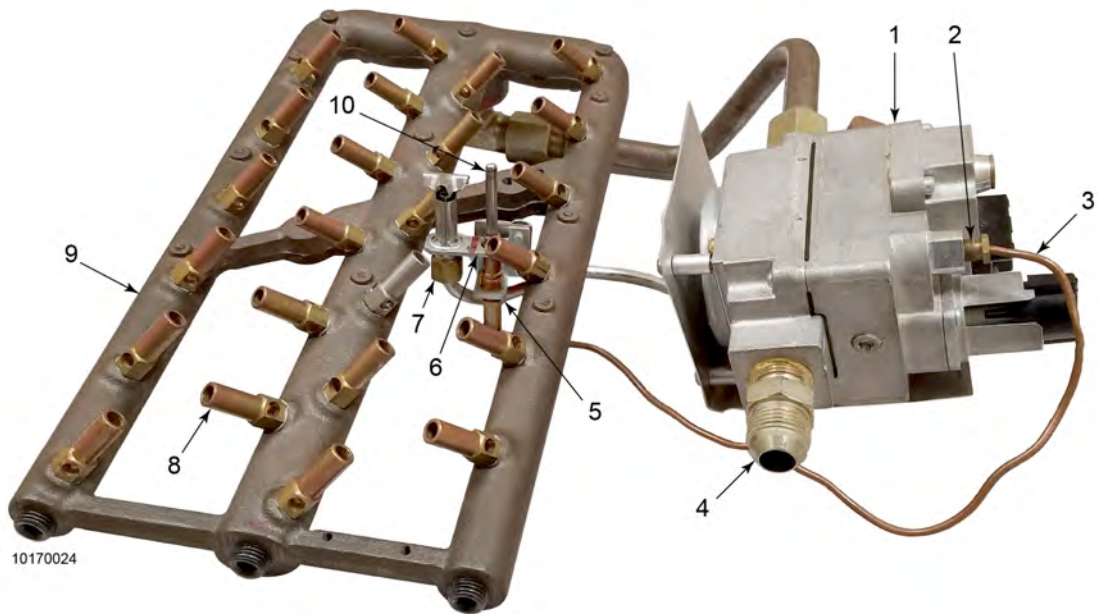

Figure 2-7 Gas Burner Assembly

## 2.12.2 Safety Precautions



### DANGER

To avoid personal injury or property damage, before starting this procedure, move the main power switch to the off position. Disconnect the main circuit breakers at the circuit breaker box or unplug service cord from wall receptacle. Turn off the main gas supply to the fryer and disconnect and cap the main supply line to fryer, or possible explosion could result.

### NOTICE:

If converting from natural gas to propane gas or from propane gas to natural gas, conversion must be done by a qualified service technician.

## 2.12.3 Replacement

- 1) Remove the control panel per [2.4 Lower the Control, page 14](#).
- 2) Place the control panel back in upright position, in the metal flanges.
- 3) Remove wires from the gas control valve (1), see [Figure 2-7 Gas Burner Assembly, page 28](#).

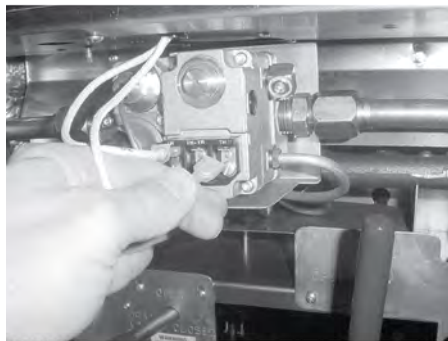

10170027

- 4) Disconnect gas supply line (1) from the connector (2) at control valve, see [Figure 2-8 Gas Supply Connection, page 30](#).

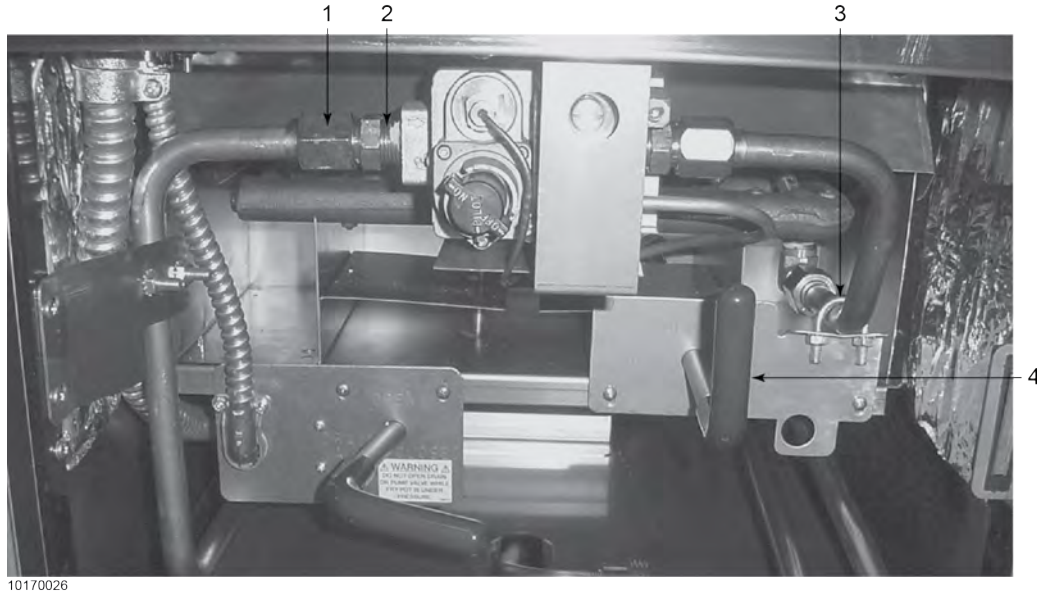

10170026

**Figure 2-8 Gas Supply Connection**

- 5) Loosen the two screws (13) on the heat shield deflector (9), on the firebox and flue assembly and raise the deflector to its highest position, see [Figure 2-9 Heat Shield Deflector Assembly, page 30](#).

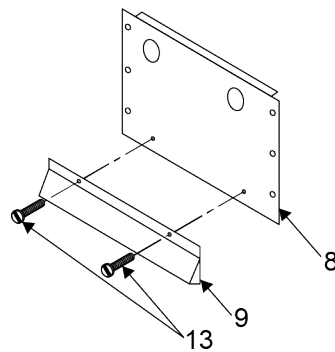

**Figure 2-9 Heat Shield Deflector Assembly**

- 6) Retighten screws (13) to hold the heat shield deflector (9) in the high position, see [Figure 2-9 Heat Shield Deflector Assembly, page 30](#).
- 7) Turn the filter valve rod (4) to the OPEN position, see [Figure 2-8 Gas Supply Connection, page 30](#).
- 8) Remove the u-bolt (3) from rinse hose bracket, see [Figure 2-8 Gas Supply Connection, page 30](#).

- 9) Remove entire gas burner assembly, by lifting and pulling toward front of fryer.
  - Replace the thermocouple (3) as required, per [Figure 2-7 Gas Burner Assembly, page 28](#).
  - Repair or replace or replace gas control valve (1) as required, see [Figure 2-7 Gas Burner Assembly, page 28](#).
  - Replace orifices (8) as required, see [Figure 2-7 Gas Burner Assembly, page 28](#).

**NOTICE:** There are 23 brass orifices and 1 stainless steel orifice. The stainless steel orifice is to be mounted adjacent to the pilot light.

- 10) Make other repairs or replacements as required.
- 11) Install entire gas burner assembly.
- 12) Install u-bolt (3) to rinse hose bracket and gas line.
- 13) Turn the filter valve handle (4) to the CLOSED position.
- 14) Loosen the two screws (13) which are holding the heat shield deflector (9) in the high position, and lower it to the normal operating position, see [Figure 2-9 Heat Shield Deflector Assembly, page 30](#).
- 15) Tighten the two screws (13) on the heat shield, see [Figure 2-9 Heat Shield Deflector Assembly, page 30](#).
- 16) Connect gas supply line (1) to the gas control valve connector (2), see [Figure 2-8 Gas Supply Connection, page 30](#).
- 17) Install the wires onto gas control valve.
- 18) Remove control panel and install it in the slot above door.
- 19) Connect the gas control valve wires to the thermostat and high temperature limit control as labeled.
- 20) Install control panel per [2.4.1 Raise the Control, page 14](#).
- 21) Uncap and reconnect the main gas supply line to the fryer. turn on the main gas supply.

**DANGER!** Leaking gas may cause an explosion. Check for leaks per Operator's Manual.

- 22) Connect the service cord to the wall receptacle, or close circuit breakers.
- 23) Relight the gas pilot per the instructions in Chapter 2-10 Gas Pilot & Burner Lighting and Shutdown Procedure of the Operator's Manual.

## 2.13 Thermocouple

### 2.13.1 Description

The thermocouple controls the gas control valve. it generates voltage in the multivolt. this voltage signals the gas control valve to remain open to the pilot and burner. When

the voltage is not generated, the gas control valve will shut off, not allowing gas to the pilot and main burner.

### 2.13.2 Safety Precautions



**DANGER**

To avoid injury or property damage, before starting this procedure, move the main power switch to the off position. Disconnect the main circuit breaker at the circuit breaker box or unplug the service cord at the wall receptacle. Turn off the main gas supply to the fryer. Disconnect and cap the supply line to fryer, or explosion could result.

*NOTICE:*

If converting from natural gas to propane gas or from propane gas to natural gas, conversion must be done by a qualified technician.

### 2.13.3 Replacement

Removal of the thermocouple is accomplished with the main gas supply shut off. The main burner may remain inside the fryer, but the work is more easily performed with the burner removed.

- 1) Using a 3/8" wrench, remove the nut (2) securing the thermocouple in the gas control valve, see [Figure 2-7 Gas Burner Assembly, page 28](#).
- 2) Remove the nut (7) securing the thermocouple in the pilot holder, see [Figure 2-7 Gas Burner Assembly, page 28](#).
- 3) Install the new thermocouple, being careful not to create sharp bends in the tubing. When the pilot (2) is lit, the flame must surround the top of the thermocouple, see [Figure 2-10 Pilot & Thermocouple Assembly, page 32](#).

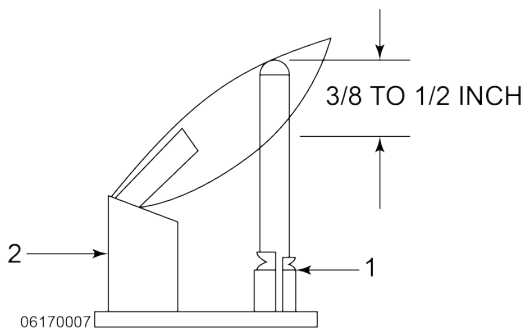

**Figure 2-10 Pilot & Thermocouple Assembly**

- 4) Turn the main gas supply and reconnect the electrical power.
- 5) Light the pilot per Chapter 2-10 Gas Pilot & Burner Lighting and Shutdown Procedure of the Operator's Manual and test the fryer for proper operation.

## 2.14 Gas Control Valve

### 2.14.1 Description

The gas control valve regulates the flow of gas to the pilot and the main burner. The valve consists of: gas regulator (2), magnetic plug (4), pilot gas tube, gas valve knob, pilot adjustment cap (3) and screw, gas outlet and inlet ports, thermocouple connector, and electrical connection. The gas control valve also has a dial reference point (1)- OFF/PILOT/ON. See [Figure 2-11 Gas Control Valve, page 33](#).

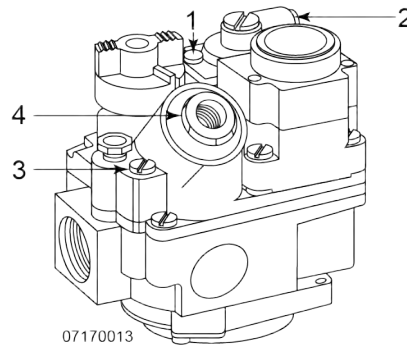

**Figure 2-11 Gas Control Valve**

The components of the gas control valve can be serviced without removing the complete valve from the fryer.

### 2.14.2 Safety Precautions



**DANGER**

To avoid injury or property damage, before starting this procedure, move the main power switch to the off position. Disconnect the main circuit breaker at the circuit breaker box or unplug the service cord at the wall receptacle. Turn off the main gas supply line to fryer. Disconnect and cap the supply line to fryer, or explosion could result.

**NOTICE:**

If converting from natural gas to propane gas or from propane gas to natural gas, conversion must be done by a qualified technician.

### 2.14.3 Operator Replacement

If the gas control valve must be replaced, remove per [2.12 Gas Burner Assembly, page 28](#).

- 1) Depress the gas valve knob and turn to OFF position.
- 2) Remove control panel per [2.4 Lower the Control, page 14](#).
- 3) Label and remove the gas control valve wires.

- 4) Using a T20 “star” screwdriver, remove the four screws securing the operator and gasket.
- 5) Secure the new operator and gasket with the four screws provided.

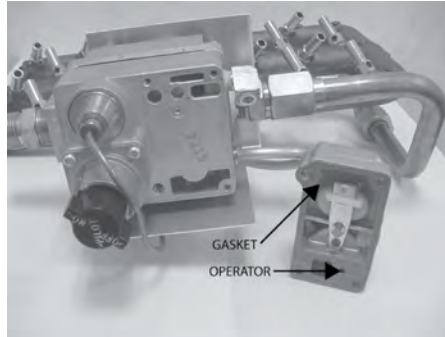

- 6) Reconnect the gas control valve wires.
- 7) Install the control panel per [2.4.1 Raise the Control, page 14](#).

**Table 2-2 Gas Control Valve Check Procedures**

Test Volts/Phase	Results
120 volt - 50/60 Hz	2350 ohms
208-240 volt - 50/60 Hz	880 ohms
24 volt - 50/60 Hz	7 ohms

## 2.14.4 Regulator Spring Replacement

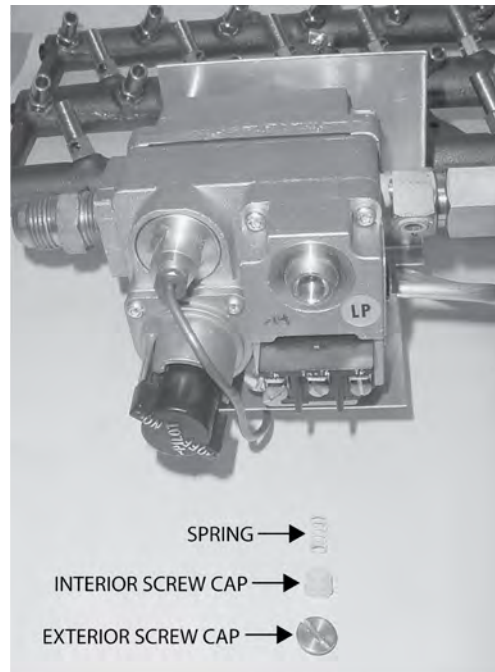

**Figure 2-12 Regulator Spring Replacement**

- 1) Remove the screw cap to the regulator.
- 2) Remove the plastic interior screw cap and spring.
- 3) Use the gas control valve manufacturer's instructions from the envelope containing the regulator spring, and follow the directions.

## 2.14.5 Adjusting Pilot Burner

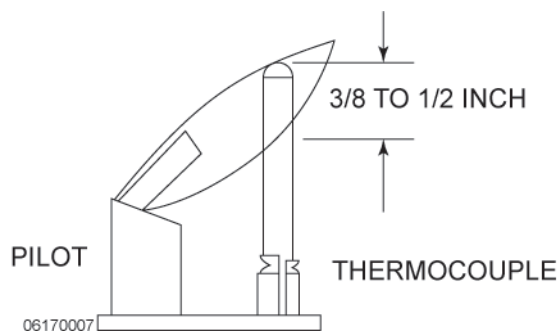

**Figure 2-13 Pilot Burner**

**NOTICE:**

The following two procedures must be performed with the gas supply reconnected and turned on. The service cord must be plugged into the receptacle and the circuit breaker on.

The pilot burner is preset at the factory. It may require resetting at the time of installation.

- 1) Remove the pilot adjustment cap.
- 2) Use a small flat screwdriver and rotate the adjustment screw counterclockwise to increase the size of the flame. Rotate clockwise the adjustment screw to decrease the size of the flame.

**NOTICE:**

The flame should be set high enough to surround the top of the thermocouple.

### 2.14.6 Adjusting Regulator

The pressure regulator is preset at the factory. It may require resetting at the time of installation.

- 1) Turn gas valve to OFF position.
- 2) Attach a manometer (2), see [Figure 2-15 Adjusting Regulator, page 37](#)) to the gas control valve at the pressure tap (1), see [Figure 2-14 Pressure Tap, page 36](#).

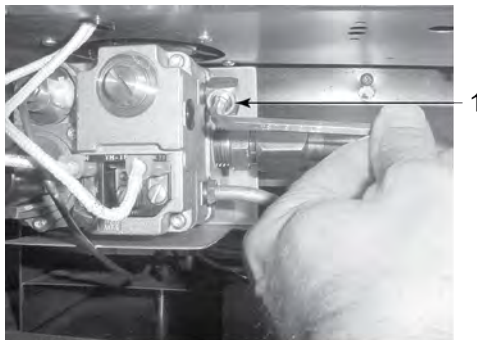

10170029

**Figure 2-14 Pressure Tap**

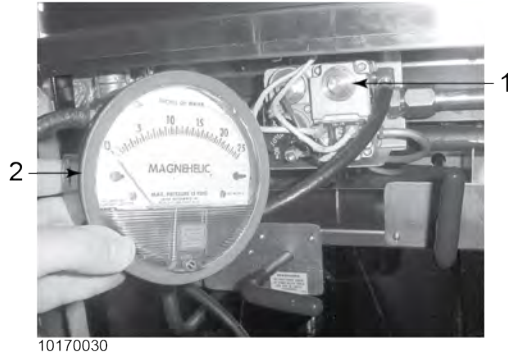

**Figure 2-15 Adjusting Regulator**

- 3) Turn gas valve knob to PILOT, light, and turn to ON.
- 4) Remove the regulator adjustment screw cap.
- 5) Rotate the adjustment screw (1) counterclockwise to increase the column indicated on the manometer or rotate clockwise to lower the column indicated, see [Figure 2-15 Adjusting Regulator, page 37](#).
- 6) Turn gas valve knob to OFF and remove manometer (1).
- 7) Replace the regulator adjustment screw cap.
- 8) Turn gas valve knob to PILOT and relight. Leak test with soap and water solution.

**NOTICE:** Natural gas regulator is factory preset at 3 1/2 inches water column. Propane gas regulator is factory preset at 10.0 inches water column.

## 2.15 Electrical Components



### **WARNING**

Do not disconnect the ground (earth) plug. This fryer must be adequately and safely grounded (earthed) or electrical shock could result. Refer to local electrical codes for correct grounding (earthing) procedures or in absence of local codes, with The National Electrical Code, ANSI/NFPA No. 70-(the current edition). In CANADA, all electrical connections are to be made in accordance with CSA C22.1, Canadian Electrical Code Part 1, and/or local codes.

### **NOTICE:**

Electric motor bearings are permanently lubricated and do not require attention during normal service life of this fryer.

## 2.15.1 Fan



### WARNING

To avoid electrical shock or property damage, move the power switch to off and disconnect main circuit breaker, or unplug cord at wall receptacle.

The gas model fryers have a fan in the circuit. This fan operates only with the Main Power switch in the ON position. The fan helps keep the control panel cool by pulling out heat from between the control panel and vat (frypot). Also, the fan pushes air down to cool the gas valve.



10170020

The replacement of a faulty fan is accomplished using the following procedure:

- 1) Remove control panel per [2.4 Lower the Control, page 14](#).
- 2) Label and disconnect fan motor wires.
- 3) Remove the four cap screws, washers, and nuts securing the fan to the heat shield.
- 4) Remove the fan from the heat shield.
- 5) Install the new fan on the heat shield and secure with the four screws, washers, and nuts.
- 6) Reconnect the fan motor wires.
- 7) Install control panel per [2.4.1 Raise the Control, page 14](#).

## 2.15.2 Drain Switch



### WARNING

To avoid electrical shock or property damage, move the power switch to off and disconnect main circuit breaker, or unplug cord at wall receptacle.

### 2.15.2.1 Gas Models



### WARNING

To avoid electrical shock or property damage, move the power switch to off and disconnect main circuit breaker, or unplug cord at wall receptacle.

- 1) The following check should be made to determine if drain switch is defective. All checks should be made with drain switch in the closed position and the power off.

- For fryers with standard thermostat part number 14293, continuity check shall be made between terminal 52 on thermostat and wire nut between drain switch and gas control valve. If the circuit is open, the drain switch is bad and needs to be replaced.

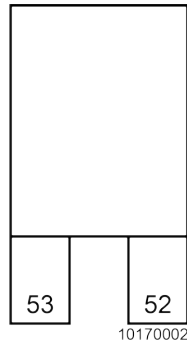

- 2) If the circuit is open, the drain switch is bad and needs to be replaced.
- 3) To replace the drain switch, remove the two screws and nuts securing the switch and switch cover.

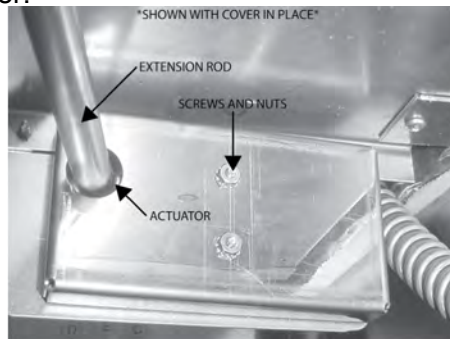

- 4) Label and disconnect the wires.
- 5) Connect the wires to the new drain switch.
- 6) Position the actuator and attach the drain switch and switch cover with the two screws and nuts.
- 7) Secure with the two screws and nuts.
- 8) Test to see if drain valve extension rod actuates the switch.

**NOTICE:** Listen for audible click of switch while rotating drain valve extension rod.

### 2.15.3 Main Power Switch



**WARNING** To avoid electrical shock or property damage, move the power switch to off and disconnect main circuit breaker, or unplug cord at wall receptacle.

The Main Power switch is a three way switch with a center OFF position. With the switch in POWER position, the fryer will operate. With the switch in the PUMP position, the filter pump will operate but the heating unit will not.

## 2.15.4 Continuity Check Procedure

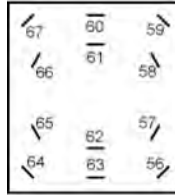

Figure 2-16 Continuity Check Test Points

Table 2-3 Continuity Check Procedure - Off Position

Test Points	Results
#60 to #59 then #60 to #67	Open circuit
#61 to #58 then #61 to #66	Open circuit
#62 to #57 then #62 to #65	Open circuit
#63 to #56 then #63 to #64	Open circuit
#60 to #61	Closed circuit
#62 to #63	Closed circuit

Table 2-4 Continuity Check Procedure - Power Position

Test Points	Results
#60 to #59	Closed circuit
#61 to #58	Closed circuit
#62 to #57	Closed circuit
#63 to #56	Closed circuit

Table 2-5 Continuity Check Procedure - Pump Position

Test Points	Results
#60 to #67	Closed circuit
#61 to #66	Closed circuit
#62 to #65	Closed circuit
#63 to #64	Closed circuit

## 2.15.5 Replacement

- 1) Remove control panel per [2.4 Lower the Control, page 14](#).
- 2) Label wires at the Main Power switch and disconnect wires at switch.
- 3) Remove faulty switch and install new switch.

- 4) Reconnect wires to switch in the same position as noted on the labels.
- 5) Replace control panel per [2.4.1 Raise the Control, page 14](#).

### 2.15.6 Indicator Lights



**WARNING** To avoid electrical shock or property damage, move the power switch to off and disconnect main circuit breaker, or unplug cord at wall receptacle.

The indicator lights for HEAT-PUMP-POWER, are identical assemblies consisting of a neon light and mounting clip, and are replaced as assemblies.

- 1) Remove control panel per [2.4 Lower the Control, page 14](#).
- 2) Disconnect indicator light wires from the individual power source.
- 3) Squeeze the retaining clip while removing the indicator light and discard the light.
- 4) Install the new indicator light.
- 5) Connect the wires from the new indicator light.
- 6) Replace control panel per [2.4.1 Raise the Control, page 14](#).

### 2.15.7 Fuse Holder



**WARNING** To avoid electrical shock or property damage, move the power switch to off and disconnect main circuit breaker, or unplug cord at wall receptacle.

There are no fuse holder assemblies for the gas models other than that at the main power source.

### 2.15.8 Checking Procedure For Fuses

**CONTROL PANEL FUSES 3 Phase:**

Check from #54 to #55 and #68 to #69 on fuse assembly. The circuit should be closed. If not, replace the fuse (HP# EF02-007).

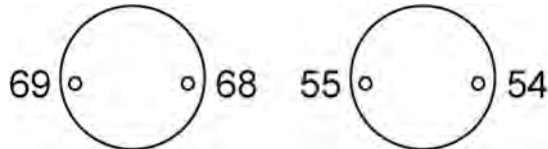

### 2.15.9 Cord & Plug Check

Perform a check on the cord and plug as follows:

Test from each plug prong to the corresponding wire lead on the other end of the cord at junction box. The result should be a closed circuit on each line tested.

### 2.15.10 Wall Receptacle (Voltage Check)

#### 2.15.10.1 Gas Models

Check the voltage across line L1 and L2.

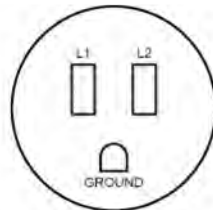

GAS FRYER

the voltage should correspond to the voltage shown on the data plate.

## 2.16 Timing Control



### WARNING

To avoid electrical shock or property damage, move the power switch to off and disconnect main circuit breaker, or unplug cord at wall receptacle.

### 2.16.1 Description

The TIMER CONTROL consists of a microswitch, indicator light, buzzer, reset timer, and timer motor.

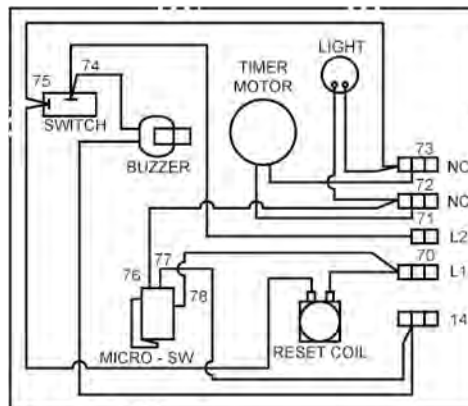

### 2.16.2 Checking Procedure

Table 2-6 Checking Procedure - ON/OFF Switch

Test Points	Results
<b>Switch in OFF Position</b>	
Check from #74 to #75	Open circuit
<b>Switch in ON Position</b>	
Check from #74 to #75	Closed circuit

Table 2-7 Checking Procedure - Buzzer Coil

Test Points	Results
<b>Switch in OFF position</b>	
Check from #14 to #75	
• 120 volt 50/60 Hz	1550 ohms
• 208-240 volt 50/60 Hz	5880 ohms

Table 2-8 Checking Procedure - Microswitch

Test Points	Results
<b>Timer Set At 10 Min.</b>	
Check from #70 to #72	Closed circuit
Check from #70 to #14	Open circuit
<b>Timer Set At 0 Min.</b>	
Check from #70 to #72	Open circuit
Check from #70 to #14	Closed circuit

Table 2-9 Checking Procedure - Motor

Test Points	Results
Check from #70 to #75	
120 volt 50/60 Hz	290 ohms
208-240 volt 50/60 Hz	3990 ohms

Table 2-10 Checking Procedure - Reset Coil

Test Points	Results
Check from #70 to #75	
120 volt 50/60 Hz	280 ohms
208-240 volt 50/60 Hz	3950 ohms

### 2.16.3 Replacement

- 1) Remove control panel per [2.4 Lower the Control, page 14](#).
- 2) Label the wires and remove them from the timer.
- 3) Remove four screws securing the timer to the control panel.

**NOTICE:**

Replacement of timer may not be necessary if lamp is burned out, if buzzer coil is burned open, or if ON/OFF switch is bad, timer motor and timer microswitch can be replaced separately.

### 2.16.4 Timer Light

- 1) Disconnect light wires from terminal board.
- 2) Remove and discard the bad light assembly.
- 3) Install new light assembly allowing retainers to snap into place.

### 2.16.5 Buzzer Coil

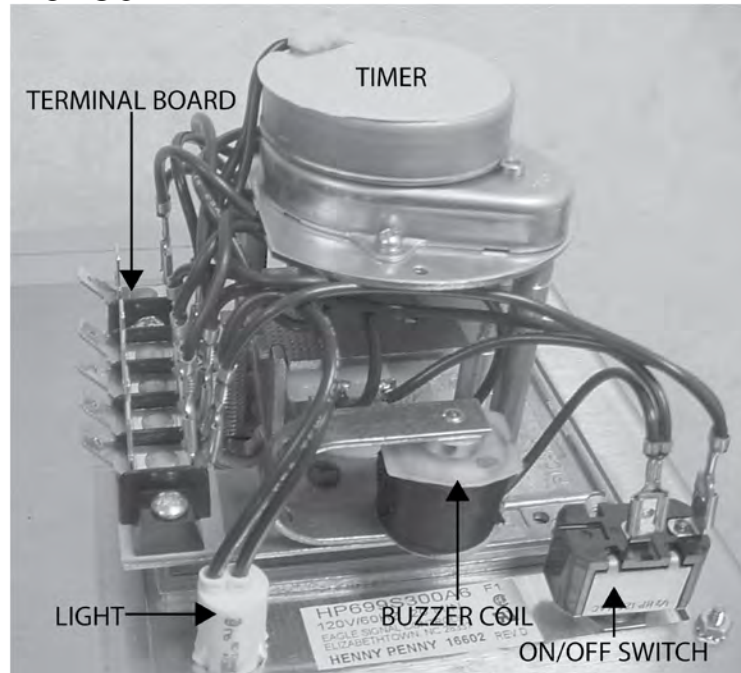

- 1) Remove buzzer and coil from timer.
- 2) Disconnect buzzer coil wires from terminal board of timer.
- 3) Install new buzzer and coil to timer.
- 4) Connect coil wires to terminal board of timer.
- 5) Install new or repaired timer on control panel and secure with four screws.
- 6) Attach wires to the timer in accordance with the labels attached.
- 7) Install control panel per [2.4.1 Raise the Control](#), page 14.

## 2.16.6 Timer Switch

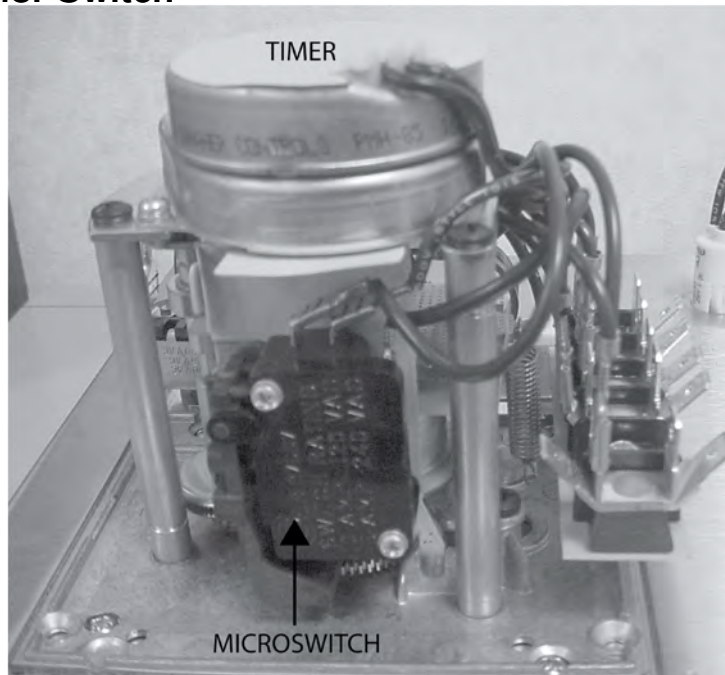

- 1) Connect light leads to terminal board of timer.
- 2) Remove switch nuts and remove switch from panel.
- 3) Disconnect switch wires from terminal board.
- 4) Install new switch on panel and secure with switch nut.
- 5) Connect switch wires to the terminal board of timer.

## 2.17 Pressure Regulation/Exhaust



### WARNING

To avoid electrical shock or property damage, move the power switch to off and disconnect main circuit breaker, or unplug cord at wall receptacle.

### 2.17.1 Solenoid Valve

This is an electromechanical device that causes pressure to be held in the vat (frypot). The solenoid valve closes at the beginning of the cook cycle and is opened automatically by the timer at the end of the cook cycle. If this valve should become dirty or the Teflon seat nicked, pressure will not build up. The fryer uses a 120 volt, 60 Hz, coil.

### 2.17.2 Coil Check Procedure

- 1) Remove wires from terminals 73 and 72 and check across solenoid wires.

Table 2-11 Coil Check Procedure

Test Volts/Phase	Results
24 volt	2.2 Ohms
120 volt 60 Hz	50 Ohms
208-240 volt 60 Hz	150 Ohms
208-240 volt 50 Hz	245 Ohms

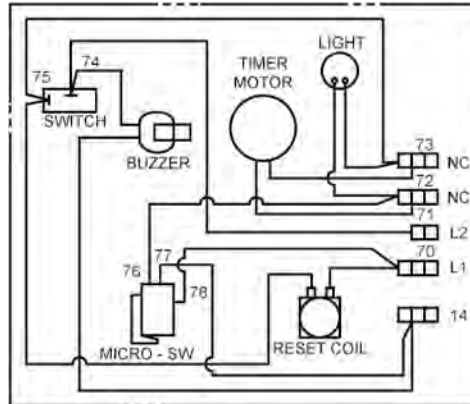

### 2.17.3 Replacement

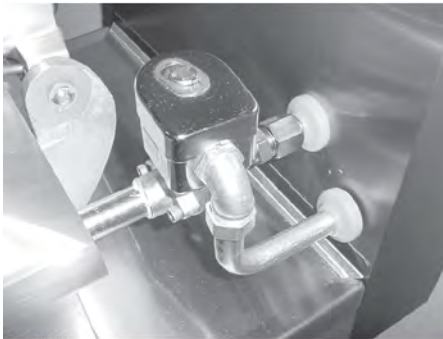
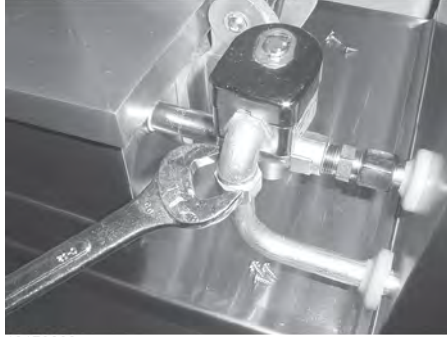

Figure 2-17 Solenoid Valve Assembly

- 1) Remove Tru-Arc retaining clip on top of the coil housing.
- 2) Remove the nameplate and cover.
- 3) If only the coil is replaced, disconnect two coil wires at the wire nuts in the coil housing, and remove the coil from the housing. Then replace nameplate, cover, and Tru-Arc clip. If the complete solenoid or seal are being replaced, continue to step 4.

**NOTICE:** The wires may be connected in any order.

- 4) Loosen the nut on the 1/2 inch connector and pull piping conduit form the valve case. Leave enough slack to remove the coil housing and yoke.



10170032

- 5) If the core-disc assembly is sticking due to buildup of shortening, breadings, and food particles, proceed with the following steps.

- Unscrew the solenoid bonnet assembly from the solenoid valve body.

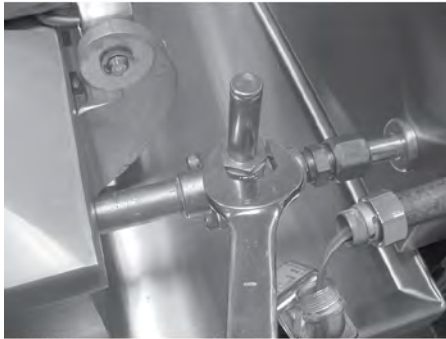

10170033

- Remove the solenoid bonnet assembly and the bonnet gasket.



10170034

- Remove the core-disc assembly, core spring retainer, and the core spring.



10170035

- Wash all parts in soap and hot water.

If replacing Teflon seals, or complete valve, proceed to step 6, otherwise assemble in reverse order of disassembly.

**NOTICE:**

Assemble valve core and blade (6), with the smooth side of the hole towards the disc spring guide (9), see [Figure 2-20 Solenoid Valve Diagram, page 50](#).

- 6) A repair kit, Henny Penny Part No. 17120, is available if any of the seals need to be replaced. If any one seal is defective, all seals should be replaced.

**NOTICE:**

Remove the solenoid body from fryer to replace seals, see [Figure 2-20 Solenoid Valve Diagram, page 50](#) to help identify all parts.

- Remove back cover.

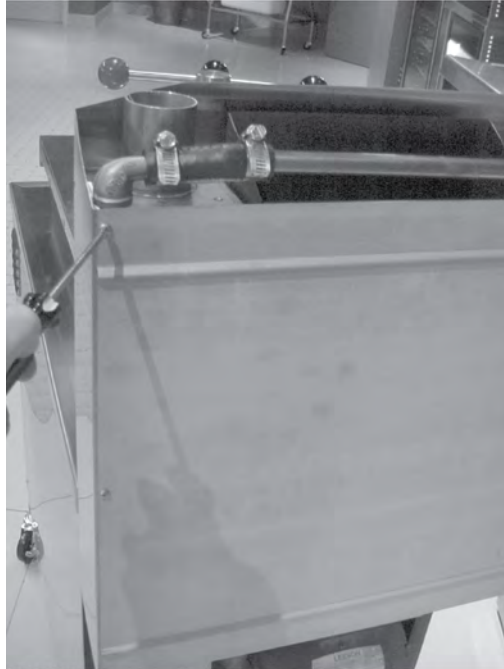

10170036

- Loosen both conduit and exhaust fittings.

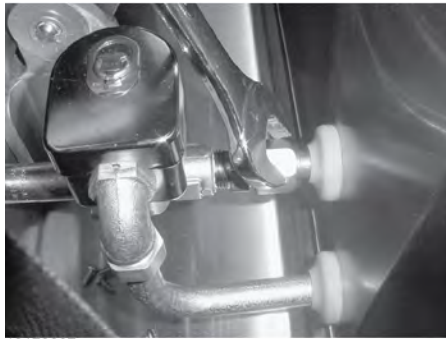

10170037

**Figure 2-18 Exhaust Fitting**



10170032

**Figure 2-19 Conduit Fitting**

- Remove nipple from solenoid body.



10170038

- Unthread body from fryer.
- A new solenoid can now be placed on the fryer, and reassembled in reverse order of previous steps, or continue onto step 7 to change the seals.

7) To change seals:

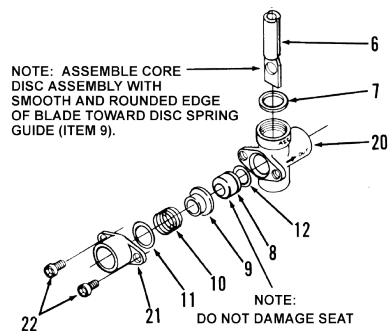

**Figure 2-20 Solenoid Valve Diagram**

- Remove the two adapter screws (22) which attach the pipe adapter (21) to the solenoid body (20).
- Remove the disc spring (10), guide (9), and seat (8).
- Clean the valve body.
- Wet O-ring (12) around seat with water and insert O-ring assembly (flat side first) in valve, through IN side of body. Use a pencil eraser, and press in Teflon seat until it snaps into place. Be careful not to mark or nick the seat.

**NOTICE:** The smallest nick can cause a pressure leak. Replace all O-ring seals, found in the parts kit, and reassemble valve.

### 2.17.4 Deadweight Valve



- DANGER**
- Do not attempt to remove the valve cap while the fryer is operating, severe burns, or other injuries could result.
  - Do not manually activate the safety relief valve. Hot steam releases from the valve when the ring is pulled. Keep body parts away from safety valve exhaust, or severe burns could result.

The deadweight valve and safety relief valve are located side-by-side at the back of the unit. The valve next to the pressure gauge is the operating control valve, and the other valve is a 14 1/2 lb. safety relief valve. Valves are working properly, when OPERATING ZONE is indicated on the gauge by the pointer. The gauge pointer should not normally exceed the operating zone. At 14 1/2 psi, the safety relief valve opens to release steam pressure from the vat (frypot).



### 2.17.5 Cleaning Steps

- 1) Clean the deadweight valve, at the end of each day. Turn the fryer OFF and release all the pressure. Open the lid and then remove the deadweight valve cap and deadweight.
- 2) Place both the cap and weight in hot detergent water and clean. Make certain to thoroughly clean inside cap, the weight seat, and around the deadweight orifice.
- 3) Rinse thoroughly with hot water. Dry parts and replace immediately to prevent damage or loss.

## 2.17.6 Removal & Cleaning of Safety Relief Valve



**DANGER** Do not attempt to remove valve while fryer is operating, severe burns or other injuries could result.

The safety relief valve should be cleaned once a year.



- 1) Open the lid and then remove the deadweight valve cap and deadweight.

*NOTICE:* Do not use a pipe wrench. Use thread sealant sparingly.

- 2) Use a wrench to loosen the valve from the pipe elbow, turn counterclockwise to remove.
- 3) Clean the inside of the pipe elbow with hot detergent.
- 4) Immerse the safety relief valve in a soap water solution for 24 hours. Use a 1:1 dilution rate. The valve cannot be disassembled. It is factory preset to open at 14 1/2 pounds of pressure. If it does not open or close it must be replaced.



**DANGER**

To avoid personal injury, do not disassemble or modify this valve. Tampering with this valve will void agency approvals and the appliance warranty, and could cause serious injuries.

## 2.17.7 Pressure Gauge

The pressure gauge can be re-calibrated should it be out of adjustment.

### 2.17.7.1 Calibration Steps

- 1) Remove the rim and glass.
- 2) If the indicating hand shows a pressure or vacuum reading when it should stand at "0", turn the re-calibrator screw in the same direction in which the indicating hand is to be moved until the hand stands at proper "0" position.

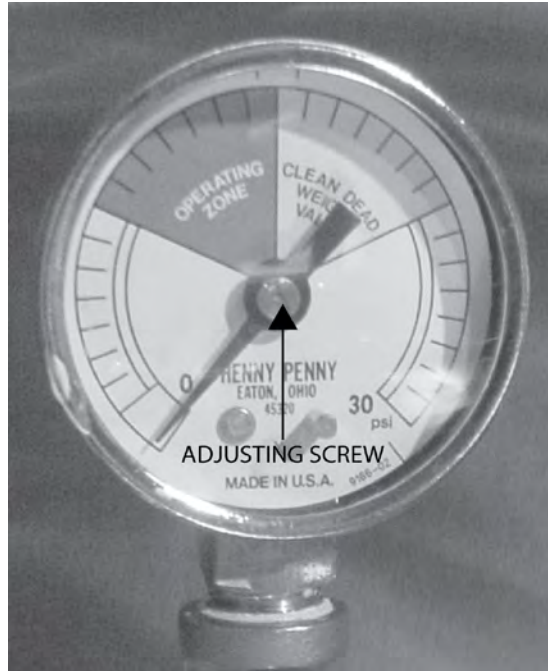

- 3) Replace rim and glass.

### 2.17.7.2 Cleaning Steps

- 1) Remove gauge and check inside the pipe fittings from deadweight body. Make certain fittings are clean and open.
- 2) Clean and reinstall gauge.

### 2.17.8 Condensation Box Assembly

The deadweight valve and solenoid exhausts are directed into a condensation box, located in the rear of the fryer. Should this box become clogged, water would spew from the top of the box. The box can be cleaned by running a wire or long brush from the top of the box, through the hole in bottom of the box, or the bottom of the box can be removed to clean.

**NOTICE:**

When cleaning the vat (frypot), pour a cup of cleaning solution into the large exhaust hose at the top of the exhaust tank. This helps prevent the box from getting clogged.

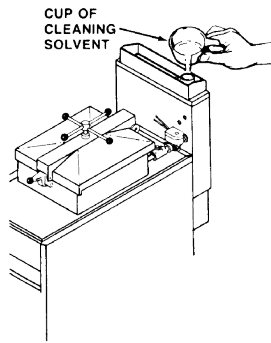

## 2.17.9 Condensation Box Bottom Removal

- 1) Loosen fitting at the bottom of the box.

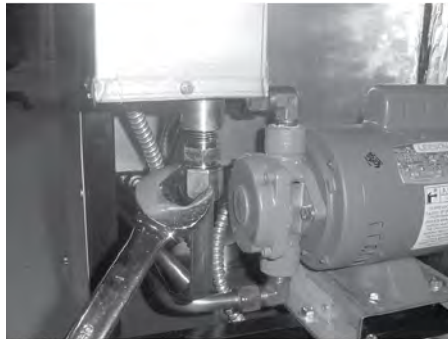

- 2) Using Phillips head screwdriver, remove 4 screws securing the bottom of the box and pull bottom from assembly.

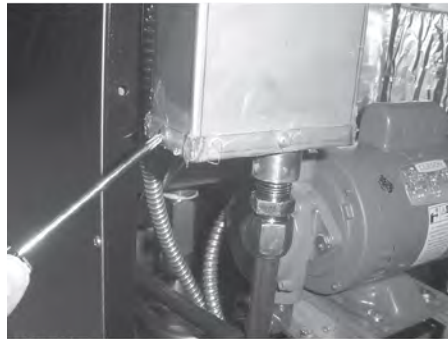

- 3) Clean outlet hole in box bottom and check condensation tube for clogs, and clean, if necessary.
- 4) Reinstall box bottom and condensation line.
- 5) Seal box bottom with silicone sealant and unit is now ready for operation.

## 2.17.10 Lid Cover Assembly

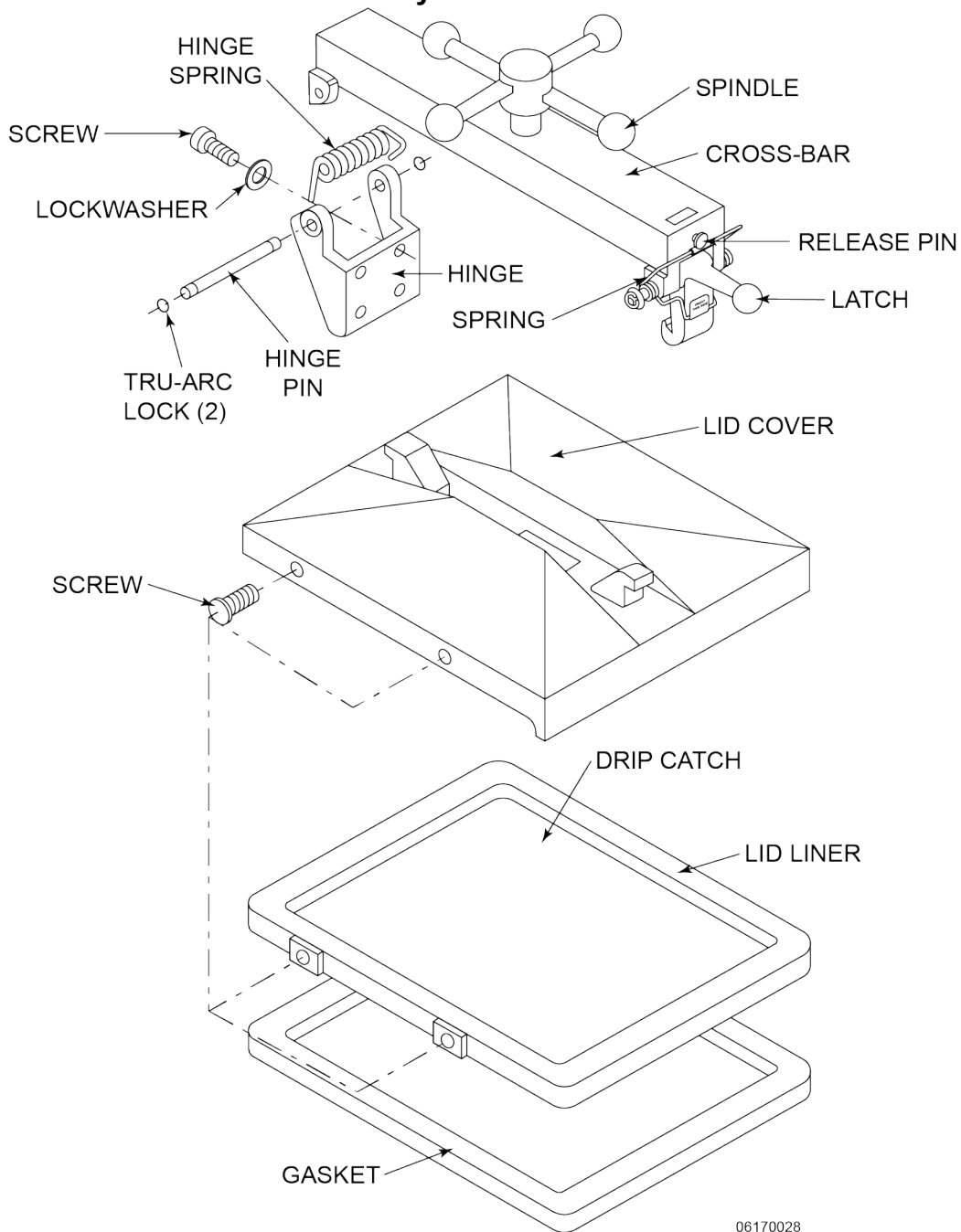

### 2.17.10.1 Description

In general, the spindle, the limit stop, the cover, the hinge, the inner and the reversible gasket comprise the lid cover assembly.

### 2.17.10.2 Lid Cover Removal

The lid cover is easily removable for cleaning or service.

- 1) Close the lid cover and turn spindle counterclockwise until it stops.
- 2) Pull the lid release pin on front of crossbar, lift the latch, and raise the crossbar.

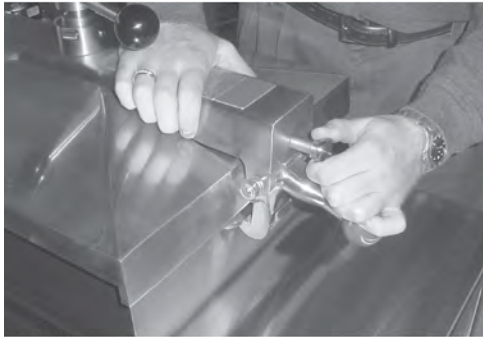

10170063

- 3) The cover can now be removed from vat (frypot).



10170064

### 2.17.10.3 Lid Cover Installation

- 1) Place the lid cover on the vat (frypot).
- 2) Thread the spindle counterclockwise until it is completely extended.
- 3) Align the rear retaining hook on lid cover in the center slot of the crossbar. Push the crossbar down and pull out on lid release pin.
- 4) Push the lid to rear of vat (frypot) and latch the crossbar to the lid cover. Release the pin.
- 5) Check that lid cover is fastened properly before raising.

### 2.17.11 Lid Hinge Spring

The hinge spring needs to be replaced if it is broken, cracked or otherwise loses its tension. A special spring installation tool which greatly simplifies this procedure is available from the factory. (Henny Penny part number 14960)

- 1) Pull out on the retaining pin knob on the front of the crossbar to release lid cover.
- 2) Lift the cross bar up and away from the lid.
- 3) Remove Tru-Arc locks and hinge pin if the spring is broken. If the spring is not broken, use spring tool as described in steps 5, 6, and 7, then remove Tru-Arc lock and hinge pin.

- 4) Remove the broken spring.
- 5) The new spring is placed in the loading tool so that the spring coil is laying in the u-shaped center of the tool. The perpendicular shaft is placed in the stationary hook of the tool, and the parallel shaft is placed so the adjustable hook will tighten it down.

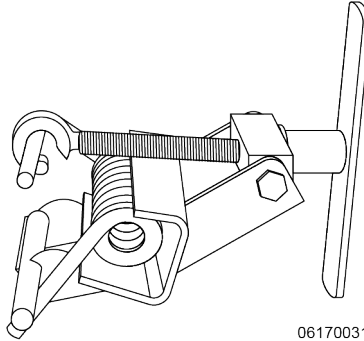

- 6) Tighten the handle on the tool as far as it will go.
- 7) Place the spring (loaded in the tool) into position so that the u-shaped center of the tool is towards the front of fryer and the tool handle is toward the top of the fryer.



- 8) Replace hinge pin and Tru-Arc locks. Loosen and remove the tool.
- 9) Reinstall the lid, see [2.17.10.3 Lid Cover Installation, page 56](#).

### 2.17.12 Latch Spring Installation



#### WARNING

To avoid severe burns and injuries make sure the lid is secure during a cook cycle. The latch spring must be in good working order and properly installed, see illustrations below. If the latch spring is weak, broken, or mounted backwards, it will provide little force against the latch.

The latch on the crossbar must have the external coil-type latch spring mounted on latch pin. If a latch spring is weak or broken, it must be replaced with a new spring, part number 33480.

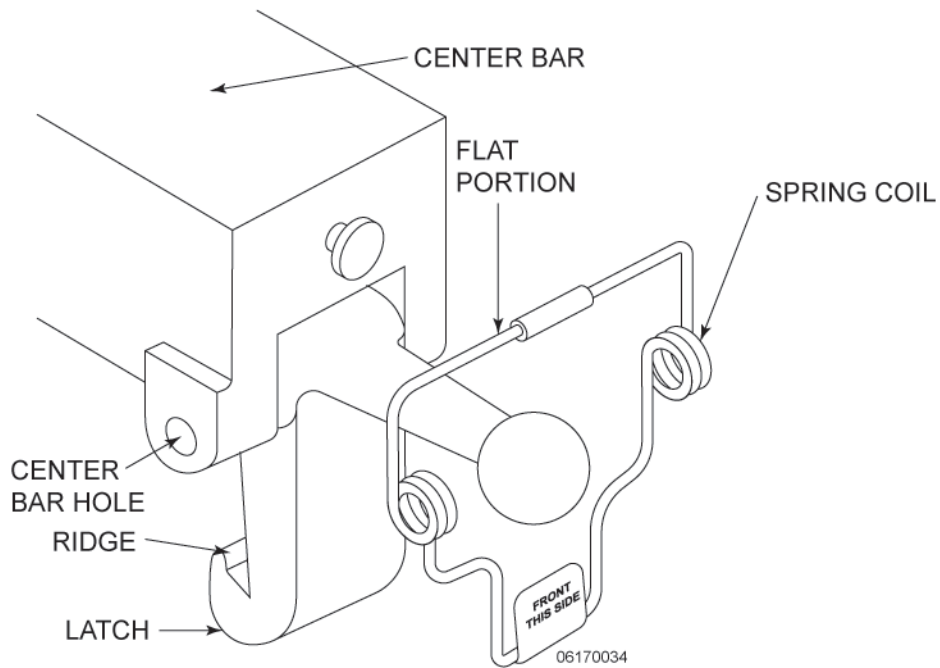

**Figure 2-21 Latch Spring Assembly**

- 1) Replace the crossbar from the lid.
- 2) With the crossbar in the upright position, remove one of the two Tru-Arc rings from latch pin.
- 3) Tap out pin from latch while grasping latch, and remove latch and latch spring.
- 4) Install new latch spring with the coils of spring extending forward.

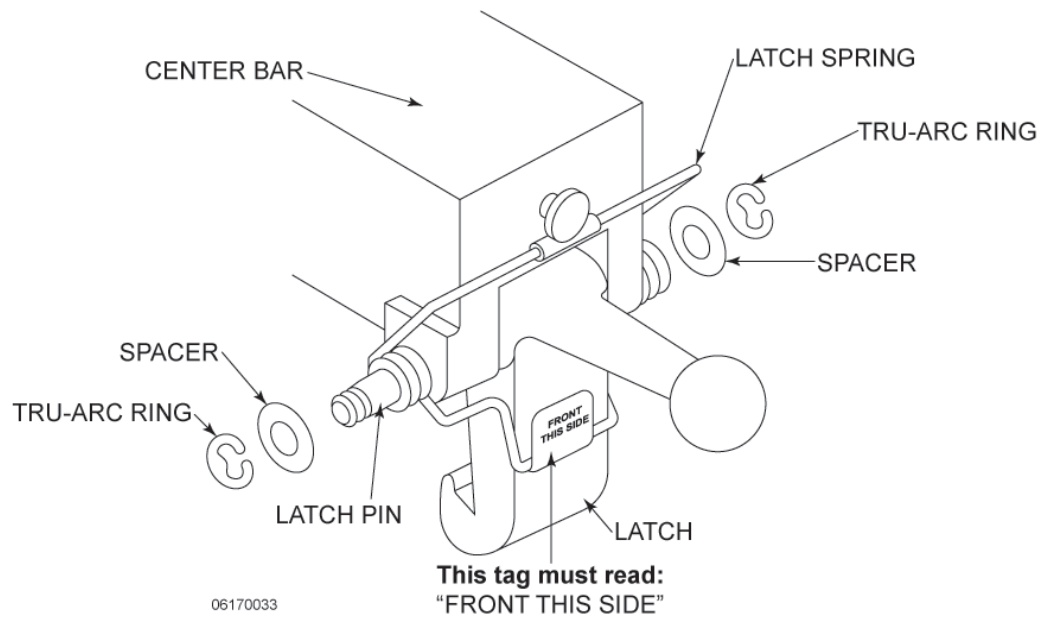

- 5) Secure spring in place with Tru-Arc ring.

### 2.17.13 Lid Liner

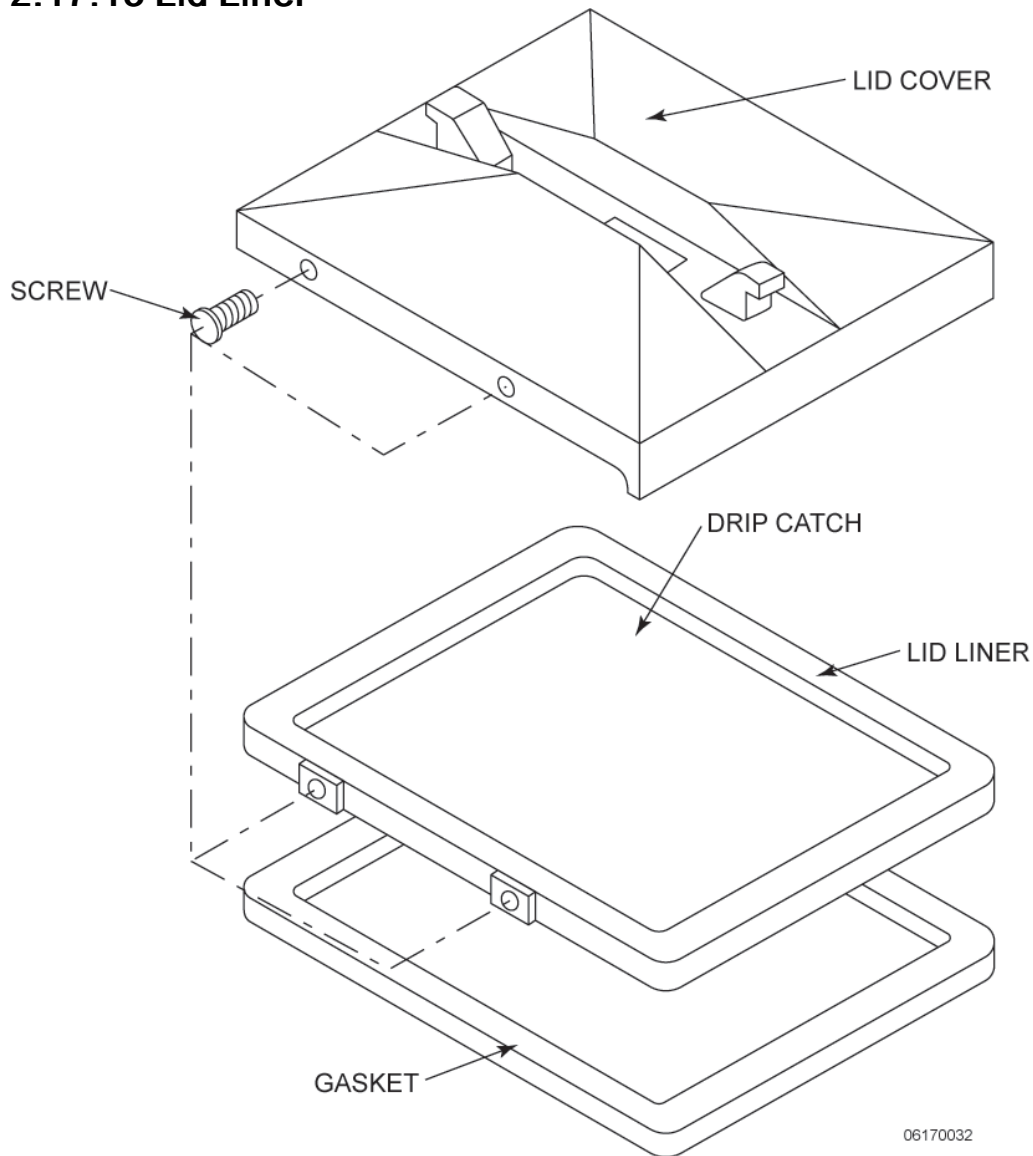

06170032

- 1) Remove the four lid liner screws.
- 2) Use a thin blade screwdriver to pry lid from the cover.
- 3) Clean the liner and the inside of the cover. Replace the liner and screws.

### 2.17.14 Reversing The Lid Gasket

The gray rubber gasket surrounding the inside of lid is designed to be reversed. Henny Penny recommends that this be done on a quarterly basis.

#### 2.17.14.1 Purpose

Because of heat expansions and the pressure used for the cooking process, the gasket is constantly under extreme stress. Reversing the lid gasket on a quarterly basis will help to assure that the fryer will not lose pressure through leakage.

### 2.17.14.2 Process

- 1) There are two lid liner screws (2) on either side of the lid cover (1), see [Figure 2-22 Lid Cover Screws, page 61](#). Back these four screws out about 1/2 inch.

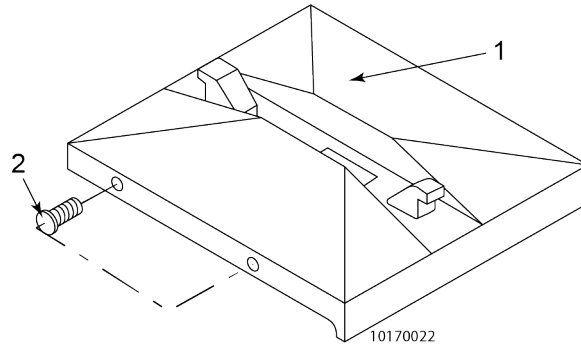

**Figure 2-22 Lid Cover Screws**

- 2) Open lid and, using a thin blade screwdriver, pry out the gasket at the corners. Remove the gasket.



- 3) Clean the gasket and gasket seat with hot water and cleaning detergent. Rinse with clean hot water.
- 4) Install the gasket with the good side facing out. Tighten the four screws.

**NOTICE:** Begin the installation by installing the four corners of the lid gasket.



10170044

### 2.17.15 Lid Limit Stop Adjustment

The lid limit stop, with proper adjustment, prevents unnecessary overtightening of the spindle, and as a result, extends the life of the lid gasket.

- 1) Loosen the Allen set screws on the bottom of the collar of the limit stop assembly.



10170045

- 2) Turn the inner collar of the limit stop clockwise as far as possible. Find the small hole in the inner collar and use a small Allen wrench or Phillips head to help in turning the collar.



10170046

- 3) Close lid and turn spindle until lid gasket meets the top of the vat (frypot) rim.
- 4) From this position, turn spindle at least 3/4 of a turn, but not over one full turn.
- 5) After rotating spindle to this point, slightly extend the spindle past this position. The spindle should then be at the seven o'clock position. It may be necessary to remove knobs and change their position in order to align the red knob with the

red knob on the lid cover latch. When in the normal operating position, both red knobs should be aligned.

**NOTICE:**

The seven o'clock position is only to allow slight additional turning of the spindle to relieve any side pressure that could hold the locking pin in the locking collar after all pressure has been released from the vat (frypot).

- 6) Adjust the limit stop by turning it clockwise until it stops against the bottom hub of the spindle.
- 7) Tighten Allen set screws.
- 8) If the lid cover fails to seal properly, steam will escape around the gasket during the frying operation. The limit stop should be readjusted. This time turn the spindle screw one full turn after the initial contact of the lid gasket against top of the vat (frypot) rim.

### 2.17.16 Spindle Screw Assembly

This assembly is used to tighten the lid cover against the vat (frypot) flange.

- 1) Loosen the set screw in the limit stop collar and loosen the limit stop.
- 2) Disengage the crossbar from the lid cover as described in the "Lid Cover Removal". Leave the lid cover in position on the vat (frypot) rim with the crossbar in the upright position.
- 3) Turn the spindle so the pin in the locking collar will be exposed.



10170047

- 4) Remove pin and locking collar. Use a small diameter punch and a hammer to drive out the pin from the locking collar. Remove the locking collar.

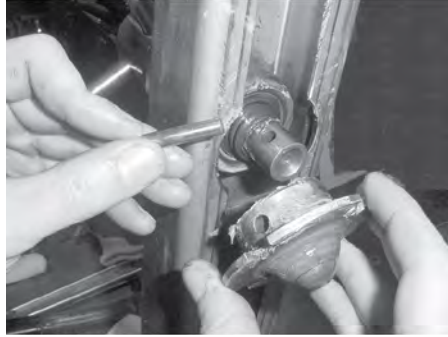

10170048

- 5) Remove the ball from the locking collar. In some cases, lightly tapping the steel ball with a hammer may be needed.



10170049

- 6) Remove and inspect the idle nut.



10170050

- 7) Thread the spindle out of the acme nut.



10170051

- 8) Loosen the Allen set screw in the outer ring of limit stop. Thread the inside portion up and down several times to check for ease of operation. If thread feels tight or must be forced, threads may be damaged. Discard and replace with new limit stop assembly.

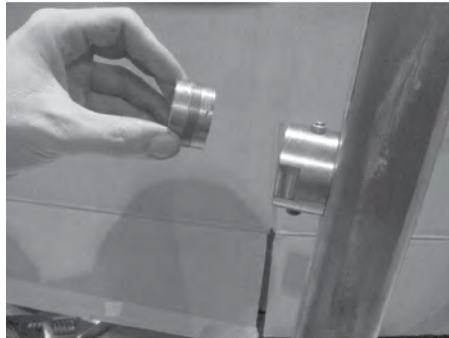

10170052

**NOTICE:**

The acme nut must be changed when there is excessive play and movement between the spindle and the acme nut.

- 9) Using a nylon tape type wrench, unthread the limit stop collar from the acme nut.



10170053

- 10) Gently tap the acme nut from the center crossbar. Inspect the acme nut for thread damage. If the threads are thin and sharp, or worn, replace with a new acme nut.



10170054

11) Use an Allen wrench and ratchet to remove the retainer.



10170055

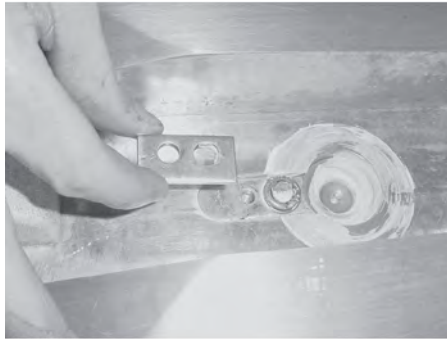

10170056

12) Remove the locking pin and spring. Inspect and replace, if necessary.



10170057

**NOTICE:**

When reinstalling the locking pin, be certain it is put back in its original position. The angled side of the pin should be to the right.

- 13) Use a magnet to remove the ball seat. Inspect and replace if necessary.



10170058



10170059

- 14) Install the acme nut and limit stop collar. Lubricate the acme nut with special grease (Part No. 12124).
- 15) Thread the limit stop assembly into the limit stop collar.
- 16) Lubricate the spindle with special grease. (Part No. 12124) every 30 days.

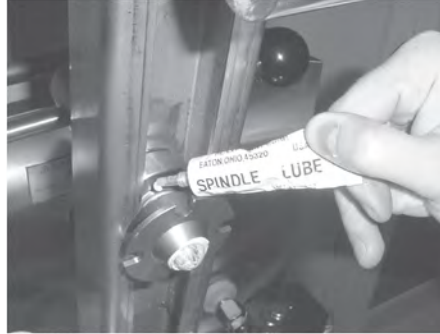

10170060

- 17) Slip the spindle through the limit stop, hold the idle nut against the acme nut, and thread spindle through both. There should be 20 to 60 thousandths between the acme nut and the idle nut. To increase dimension turn the idle nut counterclockwise; to decrease, turn clockwise.

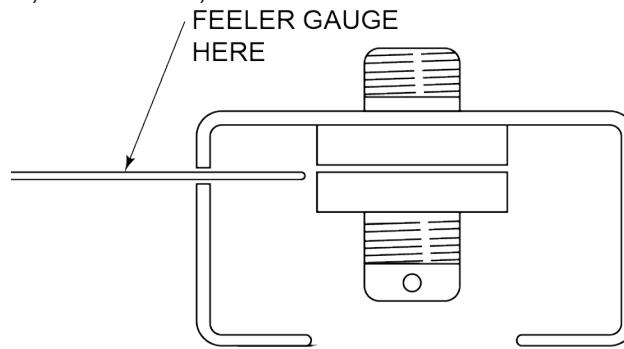

- 18) Install the locking collar, locking pin, and ball. Install the ball seat in the lid. Install the retainer spring.
- 19) Reassemble the crossbar to the lid cover according to [2.17.10.3 Lid Cover Installation, page 56](#).
- 20) Readjust the lid limit stop during the test cook cycle.

## 2.18 Filtering System

### 2.18.1 Filter Rinse Hose



**DANGER**

Shortening with temperature in excess of 200°F flows through this filter rinse hose. Heat causes the rubber hose to age and deteriorate. Severe burns will result if this rinse hose assembly leaks or ruptures. The hose and fittings should be checked daily. If aging or discoloration is seen, the hose should not be used.

The filtering system consists of the filter valve, motor and filter pump assembly, filter screen assembly, and tubing.

## 2.18.2 Removal



### **DANGER**

The hose and fitting will be hot. Use protective gloves or cloth when following this procedure or severe burns could result.

**NOTICE:** This hose is not connected to fryer during normal operation.

- 1) Close the filter valve.
- 2) Turn the pump switch to the OFF position.
- 3) Detach the hose.



10170061

## 2.18.3 Installation

- 1) Attach the filter rinse hose with its quick disconnect female fitting to the other half male fitting inside the door, next to the filter valve handle.



10170062

- 2) To do this slide back the spring ring on the female end of the quick disconnect fitting and let it snap into place over the other half male fitting.
- 3) With a quick tug on the hose, insure the quick disconnect is locked into position.

## 2.18.4 Filter Valve Description



### **WARNING**

The hose and fitting will be hot. Use protective gloves or cloth when following this procedure or severe burns could result.

The filter valve is 3/8 inch two-way stainless steel ball valve. If this valve should develop leaks the entire valve must be replaced.

## 2.18.5 Removal

- 1) Drain the shortening from the vat (frypot).
- 2) Remove the filter drain pan from the fryer.
- 3) Remove the cotter pin, handle, and extension rod.
- 4) Remove the pipe from between the filter pump and valve.

**NOTICE:** If fryer is equipped with optional filter rinse hose attachment, disconnect pipe from filter valve.

- 5) Use an adjustable wrench and remove the valve.
- 6) Replace the valve and reassemble in reverse order.

## 2.18.6 Filter Pump Repair



### WARNING

To avoid electrical shock or property damage, move the power switch to off and disconnect main circuit breaker, or unplug cord at wall receptacle.

The two most common causes for a fryer's inability to pump shortening is that the pump is clogged with breading or solid shortening has cooled and solidified in the lines and pump.

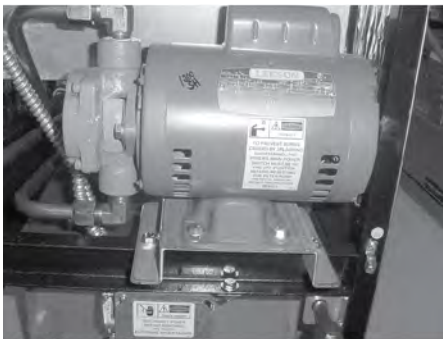

10170014

## 2.18.7 Cover Removal

- 1) Loosen the four Allen head screws on the end of pump and remove the cover.

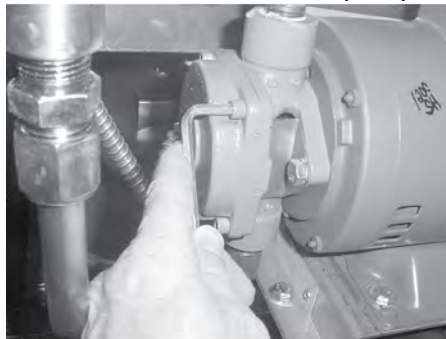

10170013

- 2) The inside is now exposed leaving a rotor and five Teflon rollers. Clean the rotor and rollers.

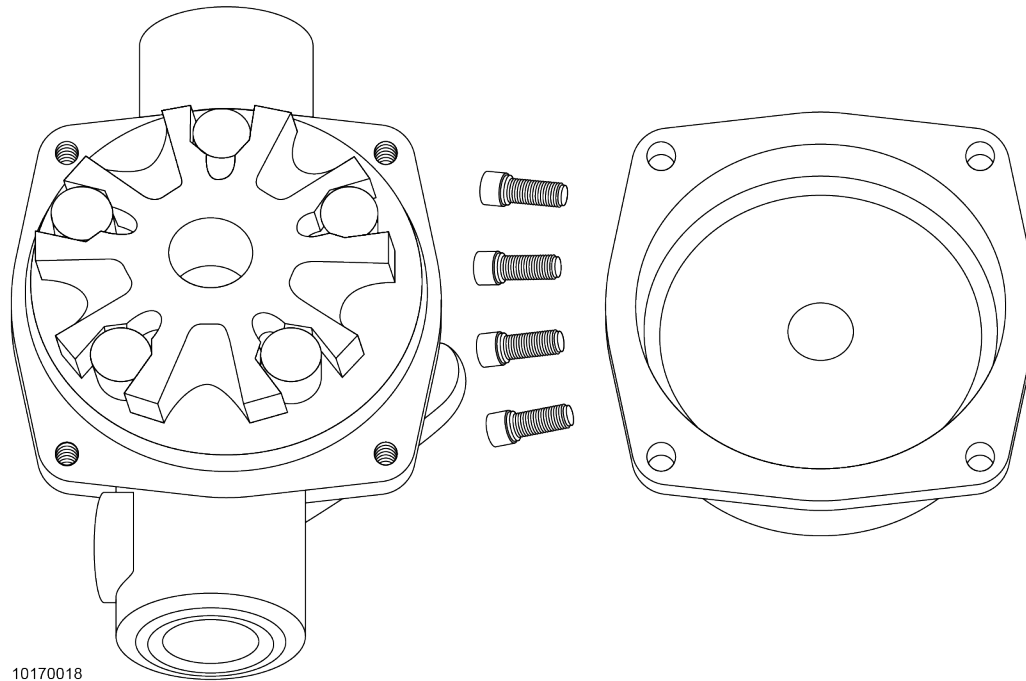

- 3) To reassemble, place rotor on drive shaft, and place roller into rotor.

**NOTICE:** A small amount of grease might be needed to hold the bottom roller into place until cover plate is put on. Make sure O-ring is in proper position on plate.

### 2.18.8 Pump Removal

- 1) If the pump needs to be replaced, loosen one inch nuts from the outflow and inflow lines. Then remove the two bolts holding the pump to the motor with a 1/2 inch wrench.

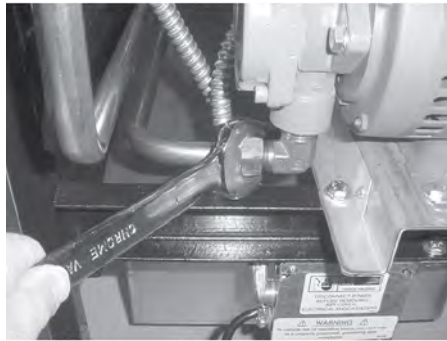

- 2) Shaft seal should remain on the motor shaft, or if leaking, could be replaced at this time.

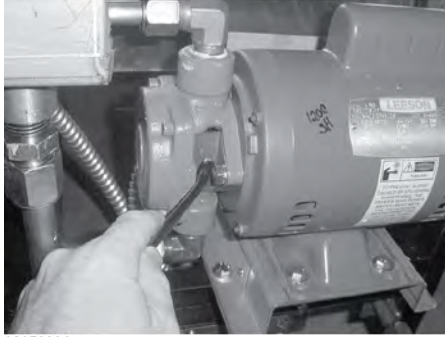

10170016

- 3) To replace the pump, remove the four Allen screws, front plate, rotor, and rollers from pump. Place the pump onto shaft and against the seal shaft. Place the 1/2 inch bolts through the pump and into the motor and tighten. Then replace rotor, rollers, front plate, and tight Allen screws.

**CAUTION!**

When removing a pump from a motor; note the positions of the inlet and outlet parts. Installation of the pump on the motor in any other position could cause damage to the fryer. There is an indicator on the side of the two halved of the pump, this mark must be together and face to the front of the fryer.

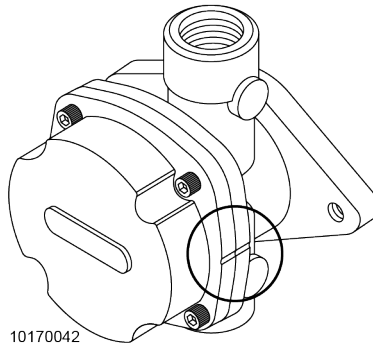

10170042

- 4) To replace the pump and motor assembly, insure the main power has been removed from the fryer.

**WARNING!**

To avoid electrical shock or property damage, move the power switch to off and disconnect main circuit breaker, or unplug cord at wall receptacle.

- 5) Remove the cover from the junction box and remove the wire nuts attaching wires leading into the flexible conduit going to the motor.
- 6) Loosen the two screws securing the flexible conduit to the 90° conduit connector (8), see [Figure 3-8 Electric Conduit Assembly, page 100](#).
- 7) Remove tubing to the pump, see [Figure 3-20 Lower Filter Plumbing Components, page 129](#) and [Figure 3-21 Upper Filter Plumbing Components, page 133](#).

- 8) Remove hardware attaching the motor to the motor base bracket and remove motor and pump assembly.

### 2.18.9 Filter Pump Motor Protector - Manual Reset



#### **WARNING**

To prevent burns caused by splashing shortening, the unit's main power switch must be in the off position before resetting the filter pump motor's manual reset protection device.

The filter pump motor is equipped with a manual reset button in the event the motor's thermal protector actuates. This reset button is located on the rear of the motor. Wait approximately 5 minutes before attempting to reset this protector device.

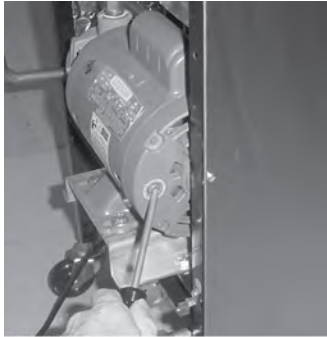

01180019

## 2.19 Gas Conversion



#### **WARNING**

Conversions must be accomplished by an authorized henny penny dealer or service representative, or personal injury could result.

Gas model fryers are factory available for either natural gas or propane gas. Factory conversion kits for natural gas and propane gas are available that require burner jets, pilot jet, and regulator assembly to be changed, see [Chapter 3 Parts Information, page 79](#) for kit identification.

### 2.19.1 Service Hints



#### **DANGER**

Never use an open flame to test for leaks, escaping gas could cause an explosion, and personal injury or property damage could result.

On natural gas installation, the gas pressure regulator on the automatic gas control valve is factory set a 3.5 inch water column.

On propane gas installation, the gas pressure regulator on the automatic gas control valve is factory set a 10.0 inch water column.

After converting the fryer, turn on the gas supply and check for leaks. A simple method is to brush all the connectors with soapy water, and watch for bubbles which indicate escaping gas.

## 2.19.2 Maintenance



### WARNING

To avoid electrical shock or property damage, move the power switch to off and disconnect main circuit breaker, or unplug cord at wall receptacle.

To convert from one type of gas to another, follow the procedure below:

- 1) Turn the gas valve knob to the OFF position.
- 2) Close the gas control valve and disconnect fryer supply line.
- 3) Remove gas control valve and burner assembly per [2.12 Gas Burner Assembly, page 28](#).
- 4) Remove the burner orifices (24 each), and replace with orifices in gas conversion kit.
- 5) Remove the pilot holder assembly and replace with the one from the kit.
- 6) Remove the gas control valve manufacturer's instructions from the envelope containing the regulator spring, and follow directions for converting the gas control valve.

*NOTICE:* Outlet pressure is stated on the enclosed label.

- 7) Attach the pressure sensitive data plate label to the data plate, covering up the old rating and pressure information.
- 8) Install converted gas control valve and burner assembly per [2.12 Gas Burner Assembly, page 28](#).
- 9) Connect the gas supply to the fryer.
- 10) Insure the power switch is in the OFF position, gas control valve in the OFF position.
- 11) Connect the electrical power to the fryer.
- 12) Check for gas leak at supply line as per [2.19.1 Service Hints, page 73](#).
- 13) Turn the gas control valve on and turn the gas control valve to the PILOT position.
- 14) Check for gas leak at the gas control valve and main gas valve per step 12 of the section. If there are no leaks, continue to step 15.



### DANGER

If a leak is detected, shut off gas control valves and repair leak. Escaping gas could cause an explosion and/or personal injury, and property damage could result.

- 15) With the gas valve knob at pilot, depress the dial and light the pilot burner per Operator's Manual.

## 2.20 Wiring Diagrams

Illustrations of the wiring diagram for Henny Penny Models 500, 561, and 600 Pressure Fryers are found in [Chapter 7 Wiring Diagrams, page 197](#).

If there is any doubt about which wiring diagram to use, please contact your distributor. As with all contacts to the distributor, include the model number and serial number from the data plate on your unit.

**NOTICE:** Refer to to explain the wire naming system for April 1, 2006 and after.

## 2.21 Caster Replacement Procedure

Casters on the fryer cannot be adjusted. Replace any damaged or broken casters by doing the following:

- 1) Discard oil from the fryer.
- 2) Using two floor jacks, position jacks near casters under the frame at point A. Both jacks must be positioned near casters on the same side of the fryer. For example, lift both the front casters off of the ground if replacing a front caster.
- 3) Block the casters on the opposite side of the fryer with small wheel chocks.
- 4) Raise fryer approximately 2.5" (63mm).
- 5) Use an adjustable wrench at point B. to remove the existing caster.
- 6) Install the new caster in reverse order.

## 2.22 Solenoid Valve



### WARNING

To avoid electrical shock or property damage, move the power switch to OFF and disconnect main circuit breaker, or unplug cord at wall receptacle.

**NOTE:** Most Controls use 24 volt solenoids. The C1000 & C2000 Controls use line voltage

This is an electromechanical device that causes pressure to be held in the vat (frypot). The solenoid valve closes at the beginning of the cook cycle and is opened automatically by the timer at the end of the cook cycle. If the valve should become dirty or the te-Aon seat nicked, pressure will not build up. The solenoid valve used on all models is the same with the exception of the coil. The gas model fryer uses a 120 volt, 60 Hz, coil. The electric model fryer uses a 208/240 volt 60 Hz coil. The 440/480 volt electric model uses a transformer to drop voltage to 220/240 volts.

## 2.22.1 Replace Solenoid Valve Assembly

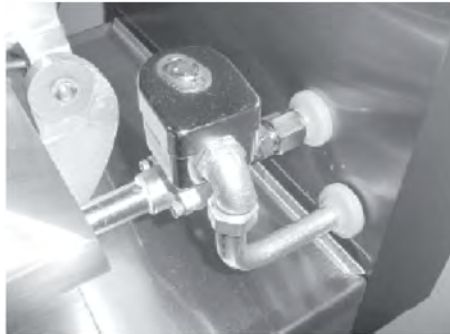

1. Remove Tru-Arc retaining clip on top of the coil housing.

2. Remove the nameplate and cover.

3. Do one of the following:

A. If only the coil is replaced, disconnect two coil wires at the wire nuts in the coil housing, remove the coil from the housing, and then replace with the new coil. Then replace nameplate, cover, and Tru-Arc clip.

B. If the complete solenoid, or seals are being replaced, continue on to step 4.

**NOTICE:** The wires may be connected in any order.



4. Loosen the nut on the 1/2 inch connector and pull piping conduit from the valve case. Leave enough slack to remove the coil housing and yoke.



5. If the core-disc assembly is sticking due to buildup of shortening, breading and food particles proceed with the following steps.

A. Unscrew the solenoid bonnet assembly from the solenoid valve body.

B. Remove the solenoid bonnet assembly and the bonnet gasket.

C. Remove the core-disc assembly, core spring retainer, and the core spring.

D. Wash all parts in soap and hot water.

A

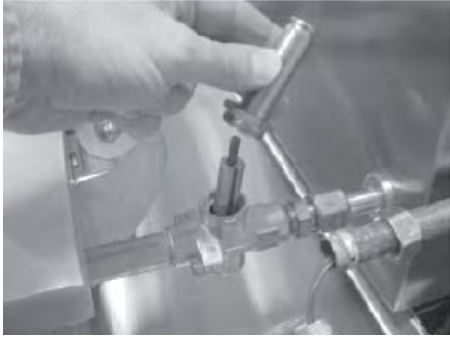

**B**



**C**

6. Do the following:

- A. If replacing Teflon seals, or complete valve, proceed to step 7.
- B. If not, assemble the core-disc in reverse order of disassembly. Assemble valve core and blade (6), with the smooth side of the hole towards the disc spring guide (9). Refer to step 8.



7. A repair kit (Part No. 17120) is available if any of the seals need to be replaced. If any of the seals are defective, all seals should be replaced.

*NOTICE:* Remove the solenoid body from the fryer to replace seals. Refer to exploded view of solenoid in figure 3-14 to help identify all parts.

- A. Remove back cover.
  - B. Loosen both conduit and exhaust fittings.
  - C. Remove nipple from solenoid body.
-

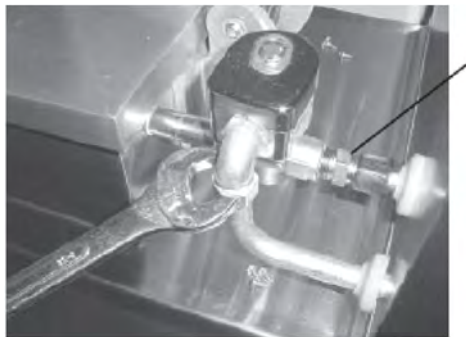
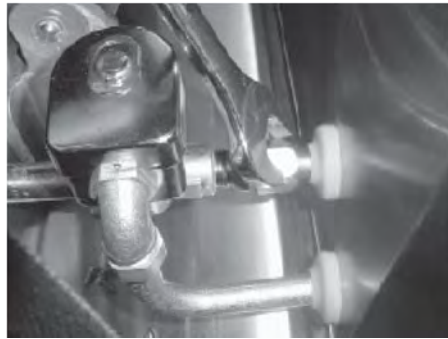

- D. Unscrew body from fryer.
- E. Install a new solenoid, and then reassembled in reverse order. Or continue onto step 8 to remove and replace the seals.

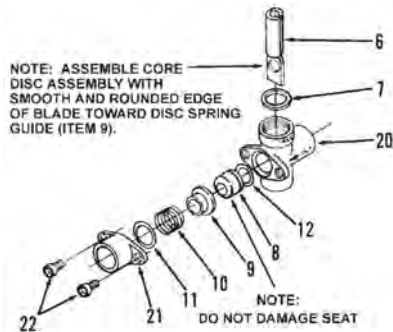

- 8. To replace the seals, do the following:
  - A. Remove the two adapter screws (22) which attach the pipe adapter (21) to the solenoid body (20).
  - B. Remove the disc spring (10), guide (9), and seat (8).
  - C. Clean the valve body.
  - D. Wet O-ring (12) around seat with water and insert O-ring assembly (flat side first) in valve, through IN side of body. Use a pencil eraser, and press in Teflon seat until it snaps into place. Be careful not to mark or nick the seat.

**NOTICE:** The smallest nick can cause a pressure leak. Replace all O-ring seals, found in the parts kit, and reassemble valve.

# Chapter 3 Parts Information

## 3.1 Introduction

This section lists and illustrates the replaceable parts of Henny Penny Model 500, 561 and 600 pressure fryers built after November 6, 2000. If your unit was built prior to that date, some differences may exist. If you have any doubts, please contact your distributor. As with all contacts to your distributor, include the model number and serial number from the nameplate on your unit.

## 3.2 Genuine Parts

Use only genuine Henny Penny parts in your fryer. Using a part of lesser quality or substitute design may result in fryer damage or personal injury.

## 3.3 How To Find Parts

To find the items you want to order, proceed as follows:

- 1) Use the index of illustrations, [3.10 Parts and Illustrations, page 83](#), to find the page number of the proper illustrations.
- 2) Referring to illustration, find the part desired and its item number.

**NOTICE**

Turn safety relief valve toward rear of fryer.

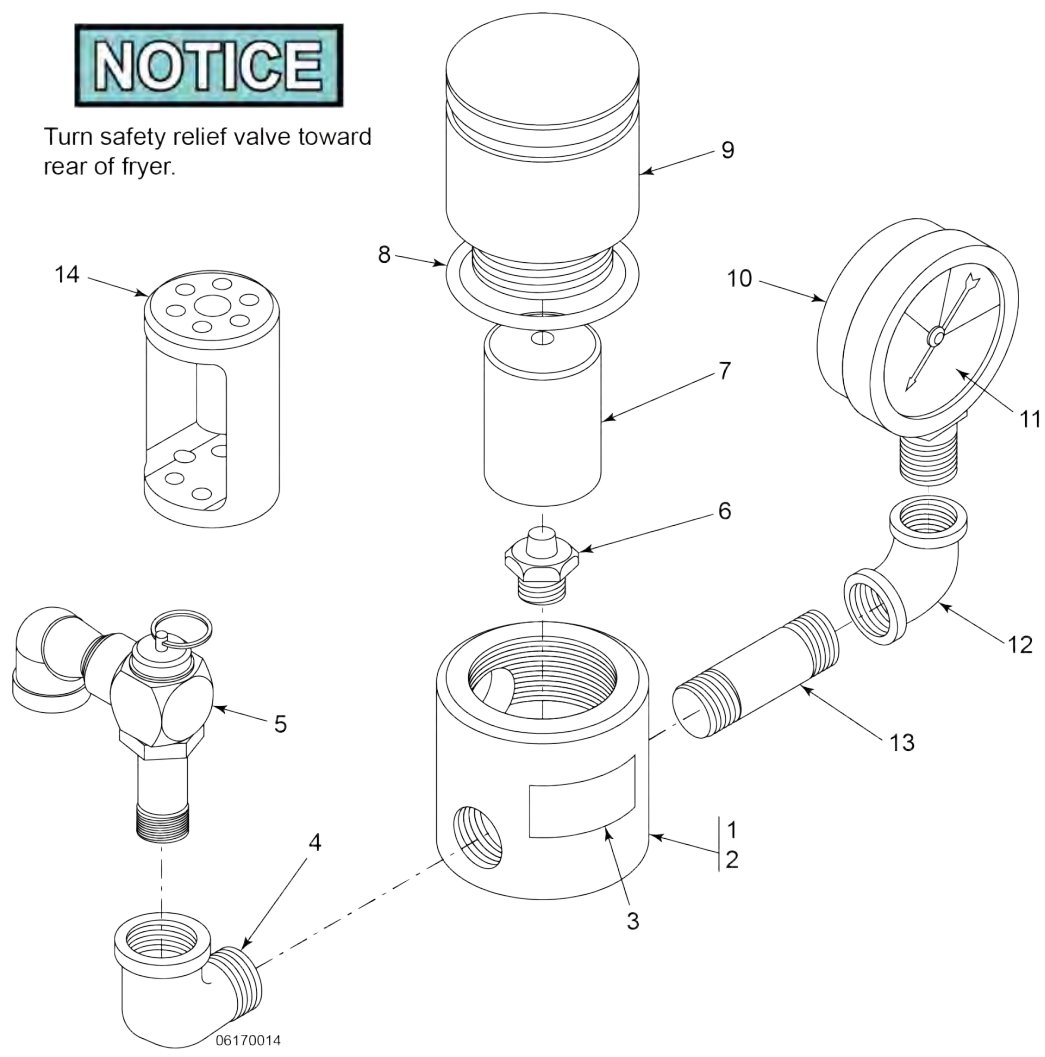

3) Find the item number in the corresponding parts list, which shows the Henny Penny part number, a description of the part, any model or usage limitations, and the quantity of parts used on that illustration.

Item No.	Part No.	Description	Qt-y.
1	14992	- KIT, PROBE - 3 INCH (ELEC)	1
2*	NS02-005	- NUT, HEX KEPS - #6-32 C	11
√ 3	60536	- ASSY., TRANSFORMER - 24V/230V	1

**3.4 Sub-Assemblies**

In some cases, items in the parts list can be purchased in groups (called subassemblies) instead of purchasing individual parts. The parts list shows these

subassemblies by indenting the description of the parts included within the subassembly. For example:

TIMER, Automatic Reset

-SWITCH, Timer

-LIGHT, Timer Indicator

-COIL, Timer Buzzer

The items can be ordered separately (switch, light, or coil), or order the timer, and all three parts are included.

### 3.5 How To Order Parts

Once you have found the parts to be ordered, write down the following information:

- 1) From the parts list:

**Example:**

Figure Number	3-3
Item Number	6
Part Number	16918
Description	DEADWEIGHT ORIFICE

- 2) From the data plate on your unit:

**Example:**

Model Number	500
Serial Number	10133

- 3) The following table has been provided as a sample format for you to use in preparing your spare parts orders. By providing all the entries, your distributor will be able to send you the correct parts. Also, prepayment expedites your order.

From Parts List			Your Order		
Figure & Item No.	Part No.	Description	Quantity Ordered	Price Each	Total Price
3-1-16	16706	KNOB, THERMOSTAT	2	2.00	4.00
3-2-47	16102	KNOB, SPINDLE - RED	1	2.00	2.00
MODEL NO.: 500		SERIAL NUMBER: 10133	Total Price: 6.00		

### 3.6 Prices

Your distributor has a priced parts list and will be glad to inform you of the cost of your parts order.

### 3.7 Delivery

Commonly replaced items are stocked by your distributor and are shipped when your order is received. Other parts are ordered, by your distributor, from Henny Penny Corporation. Normally, these are sent to your distributor within 3 working days.

### 3.8 Warranty

All replacement parts (except lamps and fuses) are warranted for 90 days against manufacturing defects and workmanship. If damage occurs during shipping, notify the sender and the carrier at once, so that a claim is properly filed, see the warranty for other rights and limitations.

### 3.9 Recommended Spare Parts For Distributors

Recommended replacement parts, stocked by your distributor, are indicated with ✓ in the parts lists. Please use care when ordering recommended parts, because all voltages and variations are marked. Distributors should order parts based upon common voltages and equipment sold in their territory.

### 3.10 Parts and Illustrations

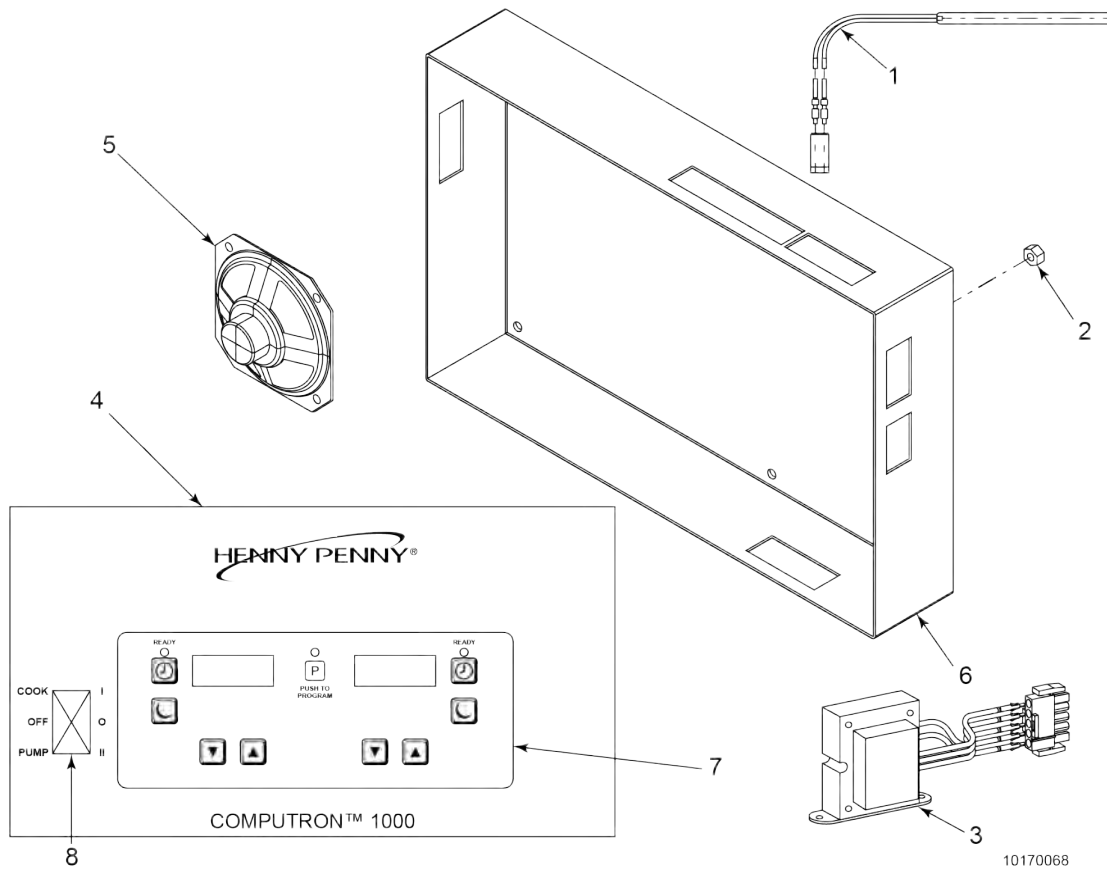
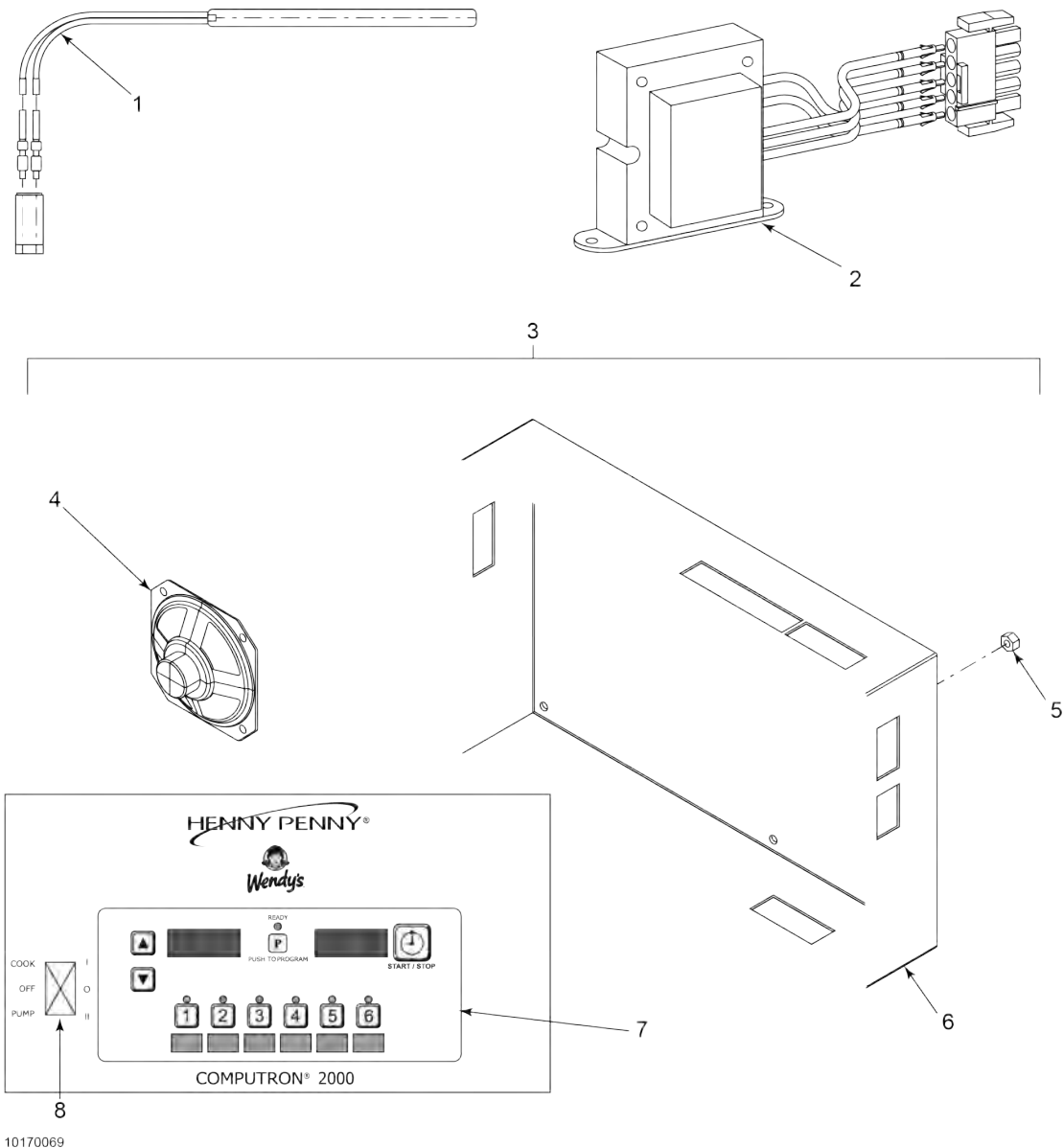

Figure 3-1 Computron C1000 Control

Item No.	Part No.	Description	Qty.
Recommended Parts * Not Shown			
-	14953	KIT, 600 E/M TO C1000 RETROFIT	1
-	14956	KIT, 600 E/M TO C1000 RETROFIT - CANADA	1
-	14406	KIT, 600 E/M 120V TO LVC C8000BP	1
-	140013	KIT, C1000 120V 600SSI TO C8000	1
-	140014	KIT, C1000 240V 600SSI TO C8000	1
1	14993	- KIT, PROBE - 6 INCH (GAS)	1
2	NS02-005	- NUT, HEX KEPS - #6-32 C	11

Item No.	Part No.	Description	Qty.
3	60536	- ASSY., TRANSFORMER - 24V/230V	1
3	60207	- ASSY., TRANSFORMER - 24V/120V	1
4	14954	- ASSY., CONTROL - C1000	1
4	14955	- ASSY., CONTROL - C1000 - CANADA	1
5	ME70-005	- SPEAKER, 16 OHM - 2 INCH	1
6	78269	- COVER, PCB	1
7	80275	- DECAL, C1000 - CONTROL - GM	1
8	29898	- SWITCH, POWER	1
9*	53669	- GUARD, POWER SWITCH	1



10170069

**Figure 3-2 Wendy's Computron C2000 Control**

Item No.	Part No.	Description	Qty.
Recommended Parts * Not Shown			
1	14993	ASSY., PROBE - 6 INCH (GAS)	1
Starting SNs: Gas - AN0801038			

Item No.	Part No.	Description	Qty.
2	60536	ASSY., TRANSFORMER - 24V/230V	1
2	60207	ASSY., TRANSFORMER - 24V/120V	1
3	14958	KIT, CONTROL - 600 C2000 WENDY'S FRYER	1
3	14959	KIT, CONTROL - 600 C2000 WENDY'S - CANADA	1
4	ME70-005	- SPEAKER, 16 OHM - 2 INCH	1
5	NS02-005	- NUT, HEX KEPS - #6-32 C	11
6	78269	- COVER, PCB	1
7	72123	- DECAL, C2000 - WENDY'S	1
7	78962	- DECAL, C2000 - WENDY'S - FRENCH	1
8	29898	- SWITCH, POWER	1
9*	53669	- GUARD, POWER SWITCH	1
10*	75820	- MENU CARD, WENDY'S - C2000	1
11*	14896	KIT, 600 E/M TO C2000 WENDY'S RETROFIT	1
11*	14934	KIT, 600 E/M TO C2000 WENDY'S RETROFIT - CANADA	1
<b>Starting SNs: Gas - AN0801038</b>			

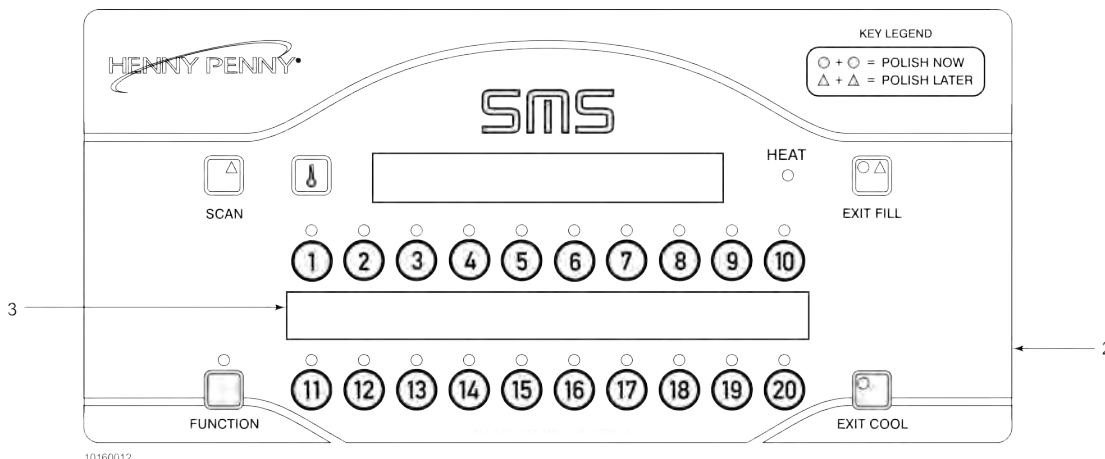

**Figure 3-3 KFC SMS-20 Control**

The SMS control has been replaced by the SMS-20 control. The SMS control is no longer orderable. The SMS kits have been updated to include to the SMS-20. The kit numbers are the same except the SMS has been replaced by the SMS-20 and any additional hardware needed to install the SMS-20, see the following tables when ordering a replacement SMS-20 control.

**Table 3-1 KFC SMS-20 Controls & Spare Parts**

Item No.	Part No.	Description	Qty.
* Not Shown			
1*	97925	CONTROL, SMS-20	1
2	97501	DECAL, KFC SMS-20	1
3	97984	CARD, MENU KFC SMS-20	1
4*	51877	SPEAKER, W/ WIRE	1
5*	14807	KIT, SMS-20 CONVERSION DOM. (KA020JJ & BELOW)	1
5*	14811	KIT, SMS-20 CONVERSION DOM. (KA021JJ TO BA026JA)	1
5*	14815	KIT, SMS-20 CONVERSION DOM. (BA027JA TO GA085JB)	1
5*	14837	KIT, SMS-20 CONVERSION INT'L (KA020JJ & BELOW) (UNITS W/ WIRING DIAGRAM 29895)	1
5*	14838	KIT, SMS-20 CONVERSION INT'L (KA020JJ & BELOW) (UNITS W/ WIRING DIAGRAM 63748)	1

Item No.	Part No.	Description	Qty.
5*	14839	KIT, SMS-20 CONVERSION INT'L (KA020JJ & BELOW) (UNITS W/ WIRING DIAGRAM 29900)	1
5*	14840	KIT, SMS-20 CONVERSION INT'L (KA020JJ & BELOW) (UNITS W/ WIRING DIAGRAM 34809)	1
5*	14841	KIT, SMS-20 CONVERSION INT'L (KA021JJ TO BA026- JA) (UNITS W/ WIRING DIAGRAM 29895)	1
5*	14842	KIT, SMS-20 CONVERSION INT'L (KA021JJ TO BA026- JA) (UNITS W/ WIRING DIAGRAM 63748)	1
5*	14843	KIT, SMS-20 CONVERSION INT'L (KA021JJ TO BA026- JA) (UNITS W/ WIRING DIAGRAM 29900)	1
5*	14844	KIT, SMS-20 CONVERSION INT'L (KA021JJ TO BA026- JA) (UNITS W/ WIRING DIAGRAM 34809)	1
5*	14845	KIT, SMS-20 CONVERSION INT'L (BA026JA GA085JB) (UNITS W/ WIRING DIAGRAM 29895)	1
5*	14846	KIT, SMS-20 CONVERSION INT'L (BA026JA GA085JB) (UNITS W/ WIRING DIAGRAM 63748)	1
5*	14847	KIT, SMS-20 CONVERSION INT'L (BA026JA GA085JB) (UNITS W/ WIRING DIAGRAM 29900)	1
5*	14848	KIT, SMS-20 CONVERSION INT'L (BA026JA GA085JB) (UNITS W/ WIRING DIAGRAM 34809)	1
5*	14908	KIT, SMS-20 CONVERSION INT'L FROM FAST TO SMS- 20 (JAPAN)	1

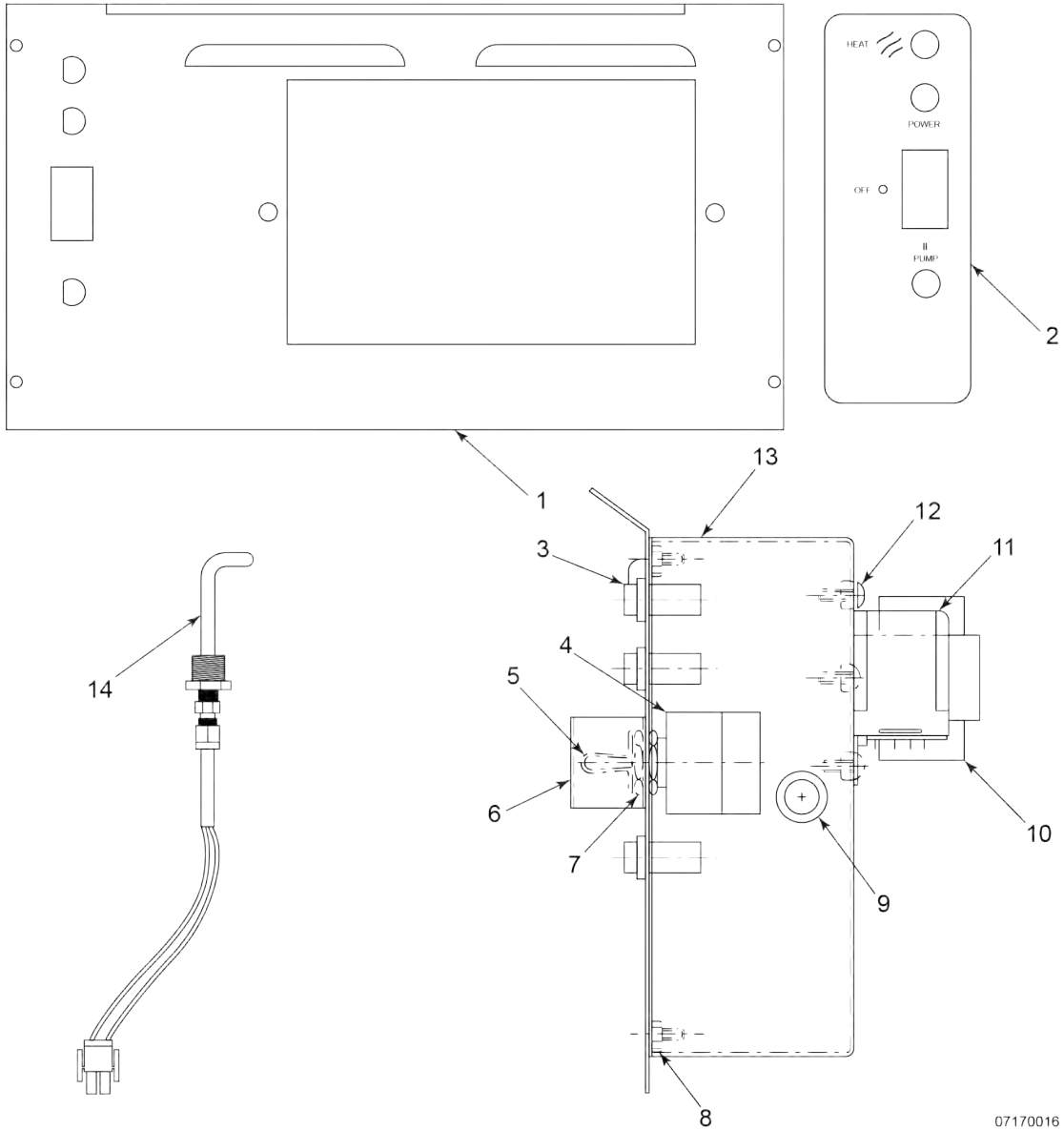
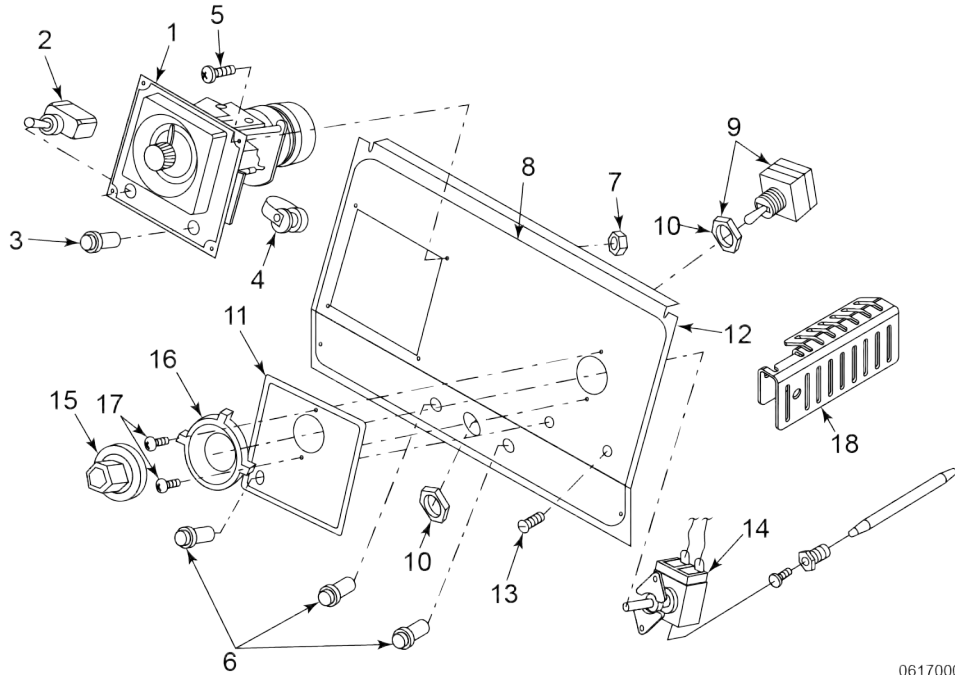

Figure 3-4 Fast Control Panel

Item No.	Part No.	Description	Qty.
Recommended Parts * Not Shown			
1	63751	FAST CONTROL PANEL, 600 - 120V (KA021JJ TO GA085JB)	1
-	140246	KIT, PFG 600 FAST CONTROL	1

Item No.	Part No.	Description	Qty.
-	63224	FAST CONTROL PANEL, 600 - 240V (KB021JJ TO HB013JB) (KA021JJ TO GA085JB)	1
1	63225	FAST CONTROL PANEL, 600 (KB021JJ TO HB013JB) (KA021JJ TO GA085JB) (CE)	1
1	27472	FAST CONTROL PANEL, 600-100-120V (GA086JB & ABOVE)	1
1	27423	FAST CONTROL PANEL, 600 - 240V (HB014JB & ABOVE) (GA086JB & ABOVE)	1
1	27424	FAST CONTROL PANEL, 600 (HB014JB & ABOVE) (GA086JB & ABOVE) (CE)	1
2	61722	- DECAL, FAST CONTROL - 600 (KB021JJ & ABOVE) (KA021JJ & ABOVE)	1
3	54085	- LIGHT, INDICATOR, GREEN (CE)	3
3	16624	- LIGHT, INDICATOR, RED	3
4	16640	- SWITCH, MAIN ASSY. - 4 PDT (KB020JJ & BELOW)	1
4	29898	- SWITCH, POWER (KB021JJ & ABOVE) (KA021JJ & ABOVE)	1
5	48369	- COVER, SWITCH (CE)	1
6	18450	- GUARD, SWITCH FRYER	1
7	NS03-018	- NUT, 3/4-32 JAM	2
8	NS02-005	- NUT, HEX KEPS #6-32 C	10
9	EF02-002	- BUSHING, 33/64 P	1
10	30614	- TRANSFORMER, 208/240V PRI-24 VS	1
10	35916	- TRANSFORMER, 120V - 50/60 Hz	1
11	30429	- RELAY, 24V COIL - 15A@120V, 10A@240V (SHOWN)	1
11*	60818	- RELAY, 24V COIL - 10A@120V, 12A@240V	1
12	SC01-049	- SCREW, #6-32 X 3/8 PH PHD C	6
13	29921	- SHIELD, BOX (KB020JJ & BELOW)	1
13	63336	- COVER, CONTROL PANEL FAST (KB021JJ & ABOVE) (KA021JJ & ABOVE)	1
14	29383	ASSY., PROBE FAST - GAS	1





06170002

Figure 3-5 Standard Control Panel

Item No.	Part No.	Description	Qty.
Recommended Parts * Not Shown			
-	16675	ASSY., CONTROL PANEL COMPLETE - BENT PANEL - 600	-
1	16602	TIMER ASSY., AUTOMATIC RESET - 115 VOLT - 60 Hz	1
1	16596	TIMER ASSY., AUTOMATIC RESET - 115 VOLT - 50 Hz	1
1	18301	TIMER ASSY., AUTOMATIC RESET - 208-240 VOLT - 60 Hz	1
1	18304	TIMER ASSY., AUTOMATIC RESET - 208-240 VOLT - 50 Hz	1
1	17366	TIMER ASSY., AUTOMATIC RESET - 208-240 VOLT - 50 Hz (CE)	1
2	22195	SWITCH, TIMER	1
3	16624	LIGHT, TIMER INDICATOR	1
4	16659	- COIL, TIMER BUZZER, 115 VOLT	1

Item No.	Part No.	Description	Qty.
4	18302	- COIL, TIMER BUZZER, 220 VOLT	1
4	14284	KIT, 600 - CONT. 230 EM BUZZER	1
5	SC01-073	SCREW, TIMER	4
6	16624	LIGHT, INDICATOR	3
6	63609	LIGHT, INDICATOR - TEMPERATURE - 48 VOLT - GAS MODELS	1
6	54086	LIGHT, INDICATOR - GREEN - CE & AUSTRALIA - GAS MODELS	3
7	NS02-009	NUT, TIMER	4
8	64427	DECAL, CONTROL (KB020JJ & BELOW)	-
8	61570	DECAL, CONTROL - WENDY'S (KB020JJ & BELOW)	-
8	61572	DECAL, CONTROL - POLLO CAMPERO (KB020JJ & BELOW)	-
8	64428	DECAL, CONTROL (KB029JJ & BELOW)	-
8	64429	DECAL, CONTROL (KA020JJ & BELOW)	1
8	61571	DECAL, CONTROL - WENDY'S (KA020JJ & BELOW)	1
8	61580	DECAL, CONTROL - POLLO CAMPERO (KA020JJ & BELOW)	1
8	61754	DECAL, CONTROL - POLLO CAMPERO (KA020JJ & BELOW) (CE)	1
8	61554	DECAL, CONTROL (KB021JJ TO HB013JB)	-
8	61570	DECAL, CONTROL - WENDY'S (KB021JJ TO HB013JB)	-
8	61572	DECAL, CONTROL - POLLO CAMPERO (KB021JJ TO HB013JB)	-
8	61709	DECAL, CONTROL (KB030JJ TO HB016JB)	-
8	61555	DECAL, CONTROL (KA021JJ TO GA085JB)	1
8	61571	DECAL, CONTROL - WENDY'S (KA021JJ TO GA085JB)	1
8	61580	DECAL, CONTROL - POLLO CAMPERO (KA021JJ TO GA085JB)	1
8	61754	DECAL, CONTROL - POLLO CAMPERO - CE (KA021JJ TO GA085JB)	1
8	61554	DECAL, CONTROL (HB014JB & ABOVE)	-

Item No.	Part No.	Description	Qty.
8	61570	DECAL, CONTROL - WENDY'S (HB014JB & ABOVE)	-
8	61572	DECAL, CONTROL - POLLO CAMPERO (HB014JB & ABOVE)	-
8	61709	DECAL, CONTROL (HB017JB & ABOVE)	-
8	61555	DECAL, CONTROL (GA086JB & ABOVE)	1
8	61571	DECAL, CONTROL - WENDY'S (GA086JB & ABOVE)	1
8	61580	DECAL, CONTROL - POLLO CAMPERO (GA086JB & ABOVE)	1
8	61754	DECAL, CONTROL - POLLO CAMPERO (GA086JB & ABOVE) (CE)	1
9	16640	SWITCH, MAIN	1
10	NS03-018	NUT, MAIN SWITCH	2
11	16745	PLATE, THERMOSTAT	1
12	18439	ASSY., CONTROL PANEL (KB020JJ & BELOW)	-
12	17524	ASSY., CONTROL PANEL (KB029JJ & BELOW)	-
12	16701	ASSY., CONTROL PANEL (KA020JJ & BELOW)	1
12	63230	ASSY., CONTROL PANEL (KB021JJ TO HB013JB)	-
12	63230	ASSY., CONTROL PANEL (KB030JJ TO HB016JB)	-
12	63230	ASSY., CONTROL PANEL (KA021JJ TO GA085JB)	1
12	27396	ASSY., CONTROL PANEL (HB014JB & ABOVE)	-
12	27396	ASSY., CONTROL PANEL (HB017JB & ABOVE)	-
12	27396	ASSY., CONTROL PANEL (GA086JB & ABOVE)	1
13	SC04-003	SCREW, CONTROL PANEL	2
14A	18382	THERMOSTAT ONLY, RS KX 365F MAX. - CE - 600	1
14B	14293	KIT, THERMOSTAT CONTROL - 600 (INCLUDES ITEMS 15, 16, & 17)	1
15	16706	- KNOB, THERMOSTAT (INCLUDED IN ITEM 14B)	1
16	16704	- BEZEL, THERMOSTAT (INCLUDED IN ITEM 14B)	1
17	SC01-023	- SCREW, THERMOSTAT (INCLUDED IN ITEM 14B)	2

Item No.	Part No.	Description	Qty.
18	N/A	- ASSY., POT CAPILLARY GUARD (PFE only, see )	1
19*	32927	WRAP, THERMOSTAT CAPILLARY	1

**Table 3-2 Fast Control Panel**

Item No.	Part No.	Description	Qty.
<b>SEE <a href="#">Figure 3-4 Fast Control Panel, page 89</a> FOR EXPLODED VIEW &amp; DETAILS)</b>			
Recommended Parts * Not Shown			
11	60818	RELAY, 24V COIL (120V)	1
20*	61722	DECAL, FAST CONTROLS	1
21*	29898	SWITCH, POWER	1
22*	18450	GUARD, POWER SWITCH	1
23*	30429	RELAY, 15A-125VAC - 10A-250VAC	1
24*	30614	TRANSFORMER, 208/240 V - PRI 24 VS	1
25*	54085	LIGHT, INDICATOR GREEN (CE)	3
26*	27472	ASSY., CONTROL PANEL - FAST - 600 - 100-120V	1
26*	27423	ASSY., CONTROL PANEL - FAST - 600 - 240V	1
27*	29383	PROBE, TEMPERATURE - FAST - 600	1

Table 3-3 Hybrid Control Panel

Item No.	Part No.	Description	Qty.
Recommended Parts * Not Shown			
1*	171285	CONTROL KIT, CFA HYBRID	1

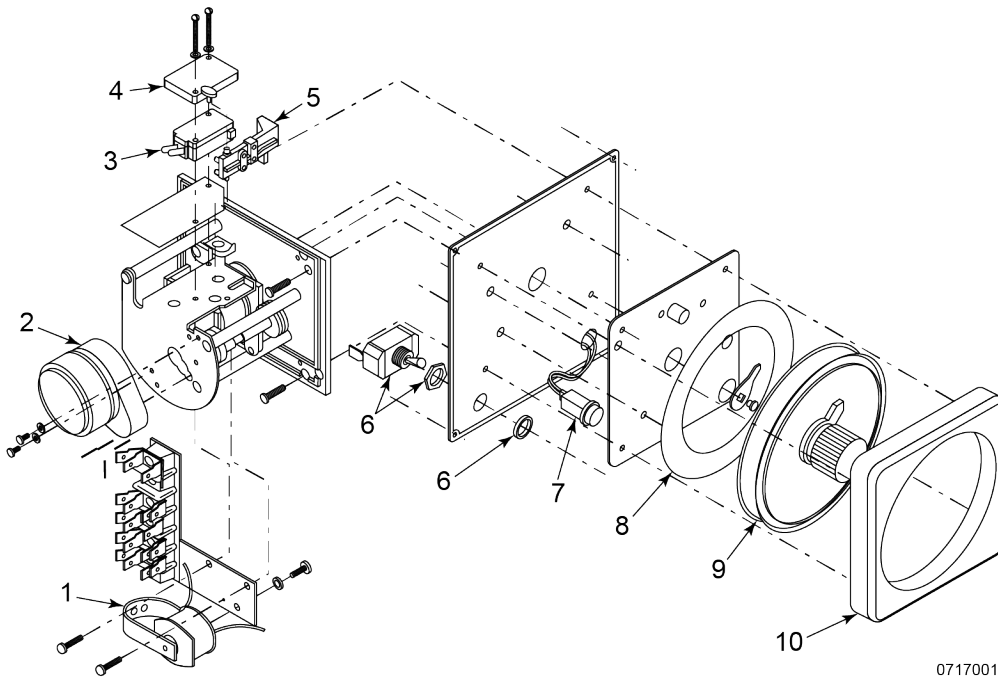

07170015

**Figure 3-6 Automatic Reset Timer Assembly**

Item No.	Part No.	Description	Qty.
Recommended Parts			
1	16659	ASSY., BUZZER COIL - 120V	1
1	18302	ASSY., BUZZER COIL - 208-240V	1
2	16673	MOTOR, TIMER- 120V	1
2	18303	MOTOR, TIMER- 208-240V	1
3	16671	MICROSWITCH, TIMER	1
4	18771	PLATE, MICROSWITCH MOUNTING	1
5	18772	ARM, MICROSWITCH ACTUATOR	1
6	22195	SWITCH, ON/OFF (INCLUDES NUT)	1
7	16624	LIGHT, INDICATOR	1
9	16371	ASSY., KNOB & POINTER	1
10	16657	BEZEL	1

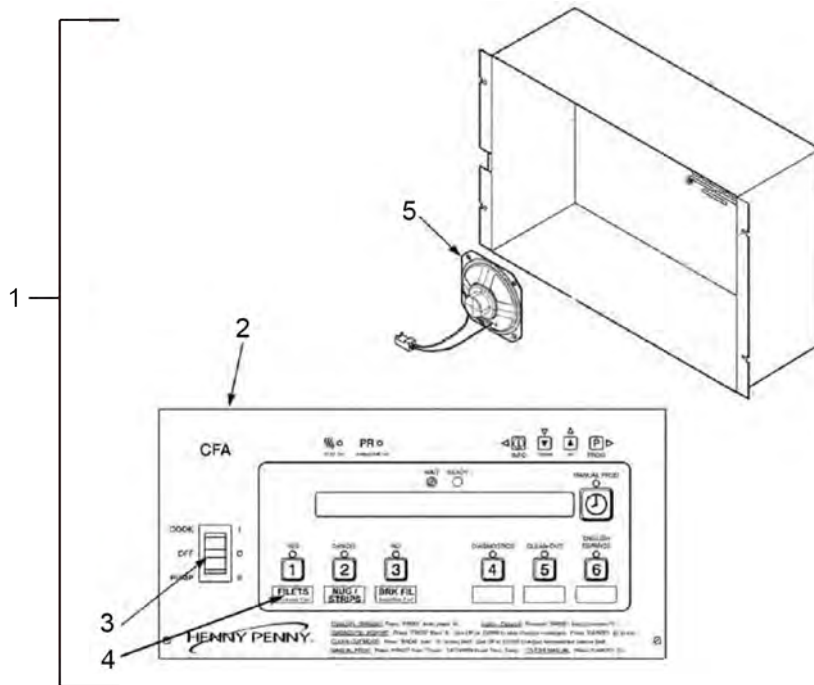
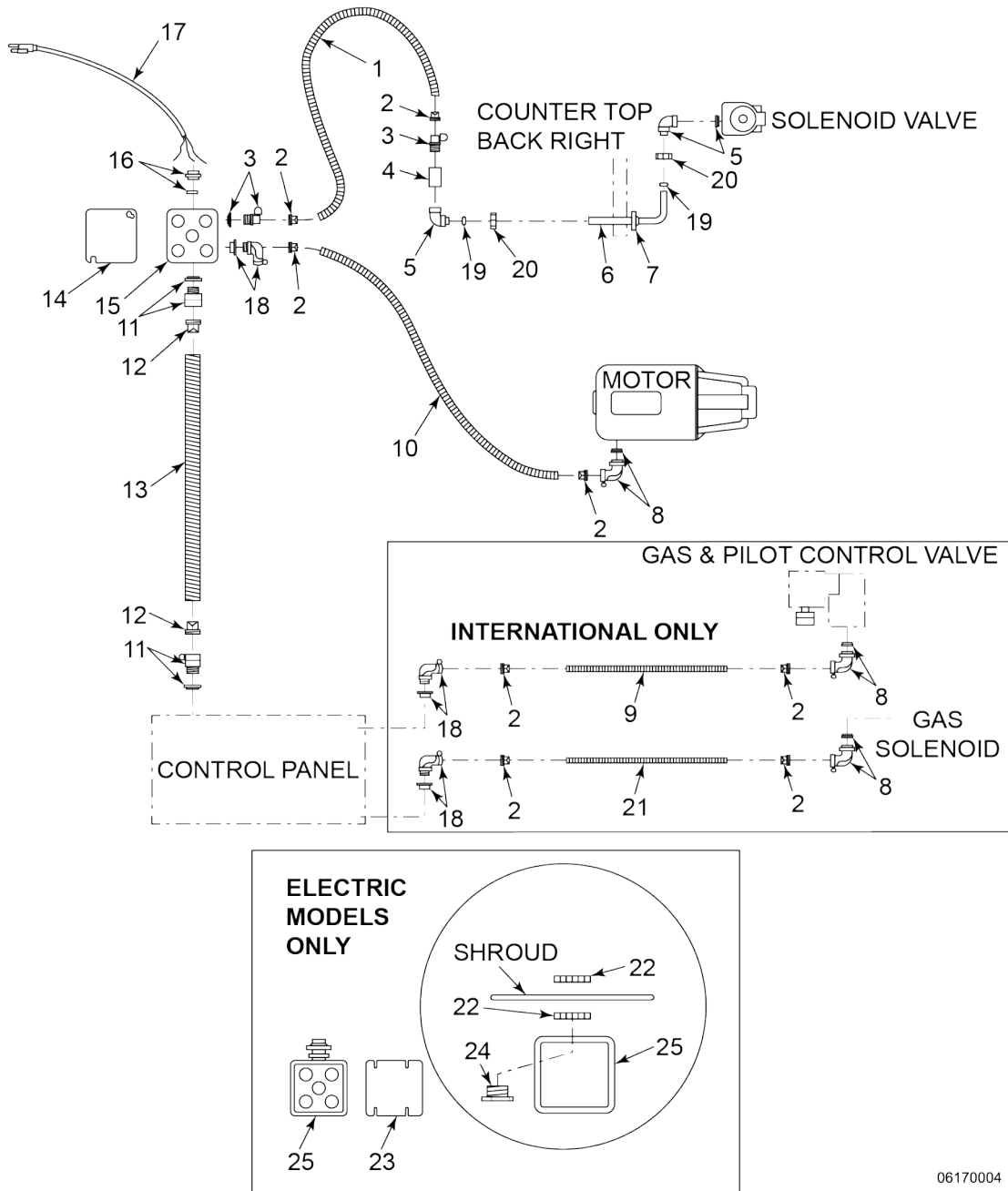

Figure 3-7 CFA Original Panel

Item No.	Part No.	Description	Qty.
Recommended Parts * Not Shown			
1	164975	CONTROL PANEL COMPLETE - Bent Panel 600 - SN: KA020JJ & Below	1
1	67544RB	CONTROL PANEL COMPLETE - Flat Panel 600 - KA021JJ to GA085JB	1
1	67830RB	CONTROL PANEL COMPLETE - Flat Panel 600 - SN: GA086JB & Above	1
2	61576	DECAL, CFA - Bent Panel - SN: 600-SN: KA020JJ & Below	1
2	24281	DECAL, CFA - Flat Panel - SN: 600-KA021JJ to GA085JB	1
2	32669	DECAL, CFA - Flat Panel '02 - SN: 600-GA086JB & Above	1
3	29898	SWITCH, COOK/PUMP	1
4	61725	MENU CARD, CFA COMPUTRON	1
5	26974	ASSEMBLY, SPEAKER	1

<b>Item No.</b>	<b>Part No.</b>	<b>Description</b>	<b>Qty.</b>
6*	ME90-011	RELAY, 24VAC COIL (DPST)	1
7*	53669	GUARD, POWER SWITCH	1



06170004

Figure 3-8 Electric Conduit Assembly

Item No.	Part No.	Description	Qty.
Recommended Parts * Not Shown			
1	18527	CONDUIT, FLEXIBLE	1
2	18105	BUSHING, ANTI SHORT	8
3	18111	CONNECTOR, CONDUIT	2
4	FP01-018	COUPLING, PIPE	1
5	18113	CONNECTOR, CONDUIT - 90°	2
6	59218	TUBE, CONDUIT - SOLENOID	1
7	16804	GROMMET, UMBRELLA	1
8	18107	CONNECTOR, CONDUIT - 90°	1
9	17221	CONDUIT, FLEXIBLE	1
9	33866	CONDUIT, FLEXIBLE - (CE & AUSTRALIA)	1
10	30291	CONDUIT, FLEXIBLE	1
11	18104	CONNECTOR, CONDUIT	2
12	18108	BUSHING, ANTI SHORT	2
13	33628	CONDUIT, FLEXIBLE	1
14	18101	COVER, JUNCTION BOX	1
15	18102	BOX, JUNCTION	1
15	54965	BOX, JUNCTION W/ COVER - SPLASH PROOF - (CE & AUSTRALIA)	1
16	18103	CONNECTOR, POWER CORD	1
17	53656	CORD, POWER - W/ GROUNDED PLUG - GAS MODELS ONLY	1
17	34823	CORD, POWER - GAS MODELS ONLY (CE & AUSTRALIA)	1
18	18644	CONNECTOR, CONDUIT	1
19	16817	SLEEVE, TEFLON	2
20	16809	NUT, FITTING	2
21	44814	CONDUIT, FLEXIBLE	1
22	19617	NUT, LOCK - 3/4 INCH	2
23	19708	COVER, JUNCTION BOX	1

Item No.	Part No.	Description	Qty.
23	32779	COVER, JUNCTION BOX - WATER TIGHT (600) (CE)	1
24	19616	NIPPLE, 3/4 INCH CHASE	1
25	19707	BOX, MAIN POWER JUNCTION	1
25	32740	BOX, JUNCTION - WATER TIGHT (600) (CE)	1
26*	51390	ASSY., EMC FILTER (CE & AUSTRALIA)	1

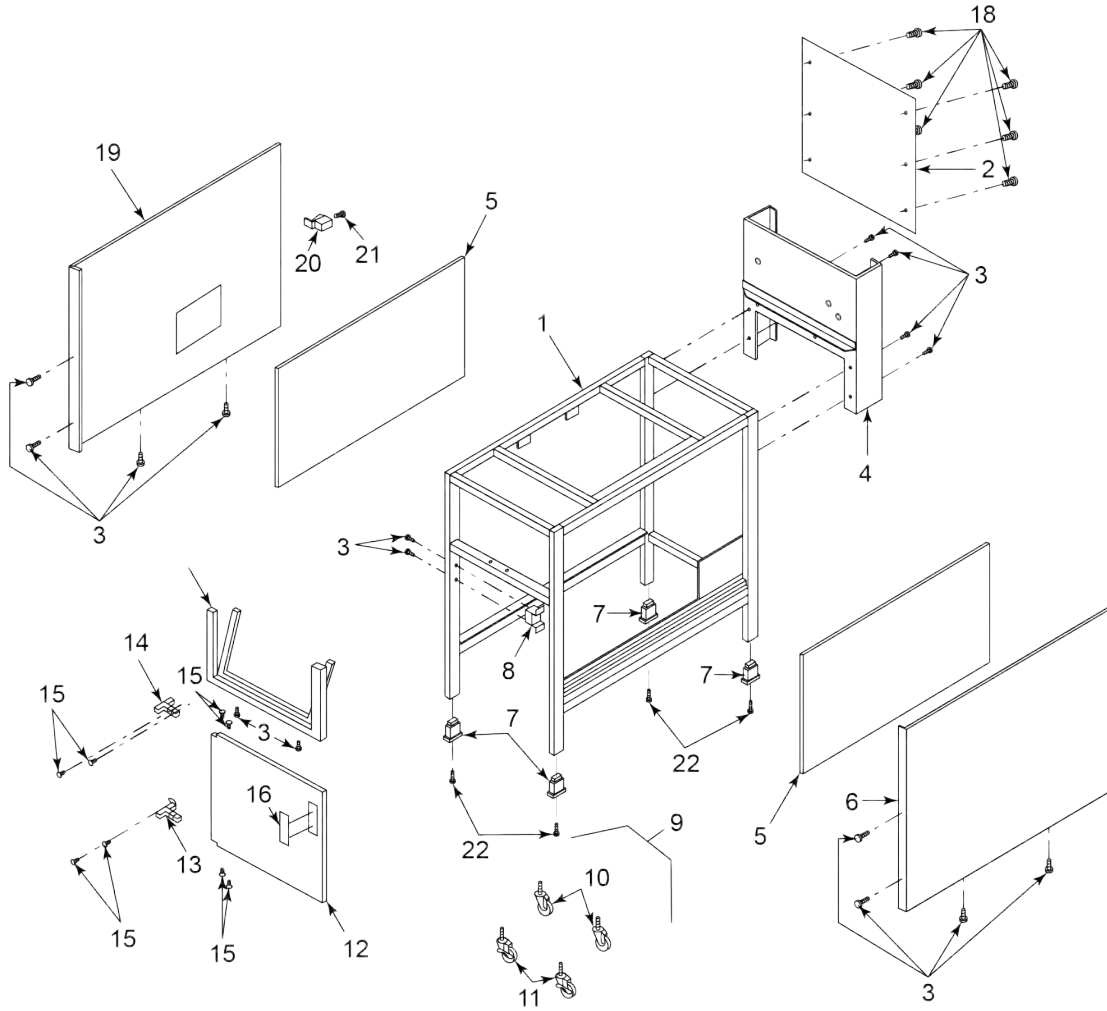

06170041

**Figure 3-9 Frame & Cabinet Assembly**

Item No.	Part No.	Description	Qty.
* Not Shown			
1	-----	ASSY., FRAME (SHORT) (KB020JJ & BELOW)	-
1	-----	ASSY., FRAME (LONG) (KB020JJ & BELOW)	-
1	-----	ASSY., FRAME (SHORT) (KB029JJ & BELOW)	-
1	-----	ASSY., FRAME (LONG) (KB029JJ & BELOW)	-
1	-----	ASSY., FRAME (SHORT) (KA020JJ & BELOW)	1
1	-----	ASSY., FRAME (LONG) (KA020JJ & BELOW)	1

Item No.	Part No.	Description	Qty.
1	64018	ASSY., FRAME (LONG) (KB021JJ TO HB013JB)	-
1	64017	ASSY., FRAME (SHORT) (KB021JJ TO HB013JB)	-
1	64018	ASSY., FRAME (LONG) (KB030JJ TO HB016JB)	-
1	64017	ASSY., FRAME (SHORT) (KB030JJ TO HB016JB)	-
1	64018	ASSY., FRAME (LONG) (KA021JJ TO GA085JB)	1
1	64017	ASSY., FRAME (SHORT) (KA021JJ TO GA085JB)	1
1	23679	ASSY., FRAME (SHORT) (HB014JB & ABOVE)	-
1	26854	ASSY., FRAME (LONG) (HB014JB & ABOVE)	-
1	23679	ASSY., FRAME (SHORT) (HB017JB & ABOVE)	-
1	26854	ASSY., FRAME (LONG) (HB017JB & ABOVE)	-
1	23679	ASSY., FRAME (SHORT) (GA086JB & ABOVE)	-
1	26854	ASSY., FRAME (LONG) (GA086JB & ABOVE)	1
2	17346	COVER, BACK SHROUD (KA020JJ & BELOW)	1
2	64255	COVER, BACK SHROUD (KB021JJ TO HB013JB)	-
2	64255	COVER, BACK SHROUD (KB030JJ TO HB016JB)	-
2	64255	COVER, BACK SHROUD (KA021JJ TO GA085JB)	1
2	24534	COVER, BACK SHROUD (HB014JB & ABOVE)	-
2	24534	COVER, BACK SHROUD (HB017JB & ABOVE)	-
2	24534	COVER, BACK SHROUD (GA086JB & ABOVE)	1
3	SC03-005	SCREW, PANELS & BRACKET - SHEET METAL	22
4	18740	ASSY., SHROUD (KA020JJ & BELOW)	1
4	67900	ASSY., SHROUD (KB030JJ TO HB016JB)	-
4	67900	ASSY., SHROUD (HB017JB & ABOVE)	-
4	67900	ASSY., SHROUD (AA1411055 & BELOW)	-
4	154672	ASSY., SHROUD (AA1411056 & ABOVE)	-
4	67900	ASSY., SHROUD (KA020JJ TO AN1411014)	1
4	154672	ASSY., SHROUD (AN1411015 & ABOVE)	1
5	59730	INSULATION, SIDE PANEL - GAS ONLY	2

Item No.	Part No.	Description	Qty.
5	59732	INSULATION, SIDE PANEL GAS ONLY (CE)	2
6	17606	PANEL, RIGHT SIDE (KB020JJ & BELOW)	-
6	48047	PANEL, RIGHT SIDE (KB029JJ & BELOW)	-
6	17606	PANEL, RIGHT SIDE (KA020JJ & BELOW)	1
6	56972	PANEL, RIGHT SIDE (KB021JJ TO HB013JB)	-
6	56972	PANEL, RIGHT SIDE (KB030JJ TO HB016JB)	-
6	56972	PANEL, RIGHT SIDE (KA021JJ TO GA085JB)	1
6	56972	PANEL, RIGHT SIDE (HB014JB & ABOVE)	-
6	56972	PANEL, RIGHT SIDE (HB017JB & ABOVE)	-
6	56972	PANEL, RIGHT SIDE (GA086JB & ABOVE)	1
6	24255	PANEL, RIGHT SIDE - GAS ONLY (KA021JJ & ABOVE) (CE & AUSTRALIA)	1
7	54225	INSERT, ALUMINUM FEET - 1 IN. X 1 IN.	4
7	17612	INSERT, ALUMINUM FEET - 1 IN. X 1-1/2 IN.	4
8	59230	BRACKET, MAGNETIC CATCH	1
8	17002	MAGNET	1
9	03007	ASSY., CASTER	1
10	17630	- CASTER, LESS BRAKE	2
11	17629	- CASTER, W/ BRAKE	2
10	151564	CASTER, 3 IN. SWIVEL STEM HD (RED)	2
11	151563	CASTER, 3 IN. SWIVEL W/ BRAKE HD (RED)	5
12	17639	DOOR ASSY., COMPLETE (KA021JJ & ABOVE - GAS)	1
12	58849	DOOR ASSY., COMPLETE (KA021JJ & ABOVE - GAS)	1
13	17620	- HINGE, BOTTOM DOOR	1
14	17618	- HINGE, TOP DOOR	1
15	SC01-072	- SCREW, DOOR HINGE	8
16	41836	- HANDLE, DOOR	1
17	17602	PANEL, FRONT (KB020JJ & BELOW)	-
17	17602	PANEL, FRONT (KB029JJ & BELOW)	-

Item No.	Part No.	Description	Qty.
17	17602	PANEL, FRONT (KA020JJ & BELOW)	1
17	56974	PANEL, FRONT (KB021JJ TOHB013JB)	-
17	56974	PANEL, FRONT (KB030JJ TO HB016JB)	-
17	56974	PANEL, FRONT (KA021JJ TO GA085JB)	1
17	83195	PANEL, FRONT (HB014JB & ABOVE)	-
17	83195	PANEL, FRONT (HB017JB & ABOVE)	-
17	83195	PANEL, FRONT (GA086JB & ABOVE)	1
18	SC04-003	SCREW, BACK SHROUD	6
19	17604	PANEL, LEFT SIDE (KB020JJ & BELOW)	-
19	17604	PANEL, LEFT SIDE (KB029JJ & BELOW)	-
19	17604	PANEL, LEFT SIDE (KA020JJ & BELOW)	1
19	56973	PANEL, LEFT SIDE (KB021JJ TO HB013JB)	-
19	56973	PANEL, LEFT SIDE (KB030JJ TO HB016JB)	-
19	56973	PANEL, LEFT SIDE (KA021JJ TO GA085JB)	1
19	56973	PANEL, LEFT SIDE (HB014JB & ABOVE)	-
19	56973	PANEL, LEFT SIDE (HB017JB & ABOVE)	-
19	56973	PANEL, LEFT SIDE (GA086JB & ABOVE)	1
19	24254	PANEL, SIDE LEFT - GAS ONLY (KA021JJ & ABOVE) (CE & AUSTRALIA)	1
20	17627	LUG, GROUNDING	1
21	17611	SCREW, GROUNDING LUG	1
22	SC01-143	SCREW, 5/8-18 X 4 HEX HD (BRIGHT FINISH) (ADJUST. LEGS)	4
22	SC-067	SCREW, 5/8-18 X 3-1/4 HEX HD (BLACK FINISH) (AD- JUST. LEGS)	4
23*	NS03-050	NUTSERT, #8-32 STEEL CAD PLATED (HINGE NUTSERTS)	4
24*	SC01-234	SCREW, #8-32 X 1/2 PH FLAT HD (DOOR TO FRAME)	4

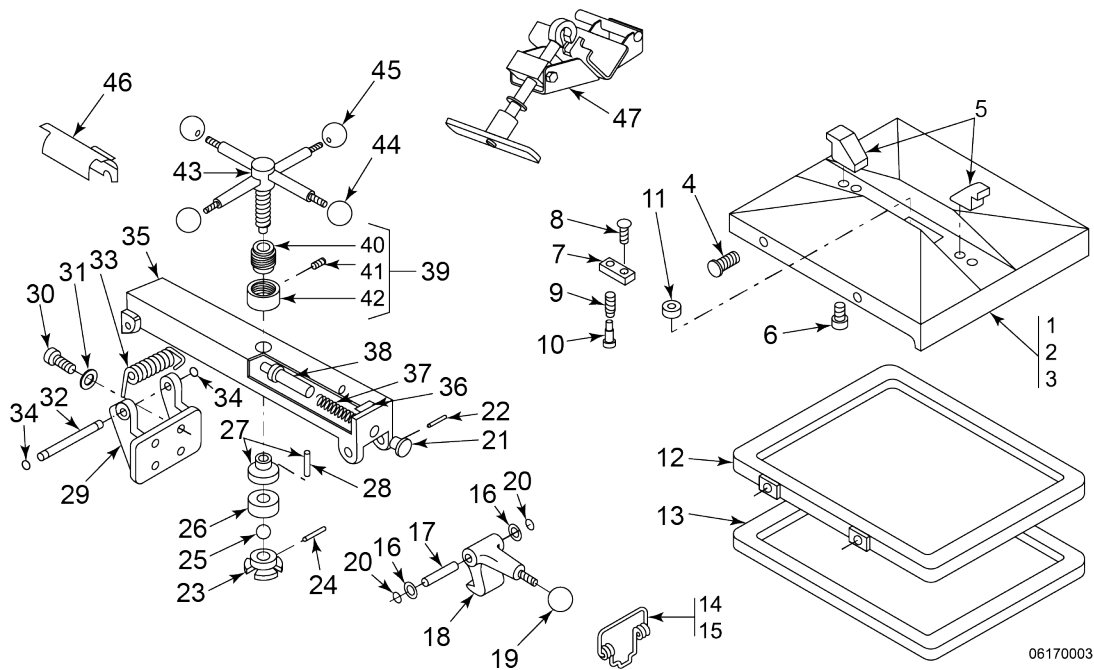

**Figure 3-10 Lid Components**

Item No.	Part No.	Description	Qty.
Recommended Parts			
1	16170	ASSEMBLY, LID	1
2	16169	- ASSEMBLY, COVER	1
3	16155	- COVER, LID	1
4	SC01-083	- SCREW, LID COVER	4
5	16133	- HOOK, COVER RETAINING	2
6	SC06-027	- SCREW, RETAINING HOOK	4
7	16166	- RETAINER	1
8	SC06-10	- SCREW, RETAINING HOOK (ALLEN HEAD)	1
9	16165	- SPRING, RETURN	1
10	16164	- PIN, LOCKING	1
11	16163	- BALL, SEAT	1
12	16119	- LINER, INNER LID (Use on units older than 03/01)	1

Item No.	Part No.	Description	Qty.
12	63729	- LINER, INNER LID (Use on units newer than 03/01)	
13	16120	- GASKET, REVERSIBLE - INNER LID LINER	1
14	16199	KIT, LATCH SPRING	1
15	33480	- SPRING	1
16	16198	- SPACER	2
17	16197	- PIN, LATCH	1
18	16116	LATCH, LID	1
19	16102	KNOB, LATCH	1
20	16121	RING, TRU-ARC LATCH	2
21	16137	KNOB, RETAINING PIN	1
22	16138	PIN, KNOB ROLL	1
23	16157	COLLAR, LOCKING	1
23	27325	COLLAR, LOCKING (CE)	1
24	16158	PIN, LOCKING COLLAR	1
24	27351	PIN, LOCKING COLLAR (CE)	1
25	16159	BALL, THRUST	1
26	27326	NUT, IDLE	1
27	27329	NUT, ACME	1
28	16162	- PIN, ACME NUT	2
29	16112	HINGE, LID ASSEMBLY	1
30	SC01-081	- SCREW, LID HINGE	4
31	LW01-010	- WASHER, LOCK - LID HINGE	4
32	16110	- PIN, LID HINGE	1
33	75293	HINGE, LID SPRING	1
34	16111	RING, RETAINER - TRU-ARC - HINGE	2
35	16154	BAR, CENTER CROSS	1
35	26884	BAR, CENTER CROSS (CE)	1
36	36099	DECAL, DANGER	1
37	16136	SPRING, RETAINING PIN	1

Item No.	Part No.	Description	Qty.
38	16135	COVER, RETAINING PIN	1
39	16171	STOP, LIMIT ASSEMBLY	1
40	16153	- STOP, LIMIT	1
41	16156	- SCREW, SET - LIMIT STOP COLLAR	2
42	16152	- COLLAR, LIMIT STOP	2
43	16168	ASSY., SPINDLE ASSEMBLY	1
43	26911	ASSY., SPINDLE ASSEMBLY (CE)	1
44	16102	KNOB, SPINDLE - RED	1
45	16101	KNOB, SPINDLE - BLACK	3
46	29587	COVER, SPRING	1
47*	14960	KIT, SPRING LOADING TOOL	1
48*	162410	GAUGE, LATCH CATCH TOOL	1

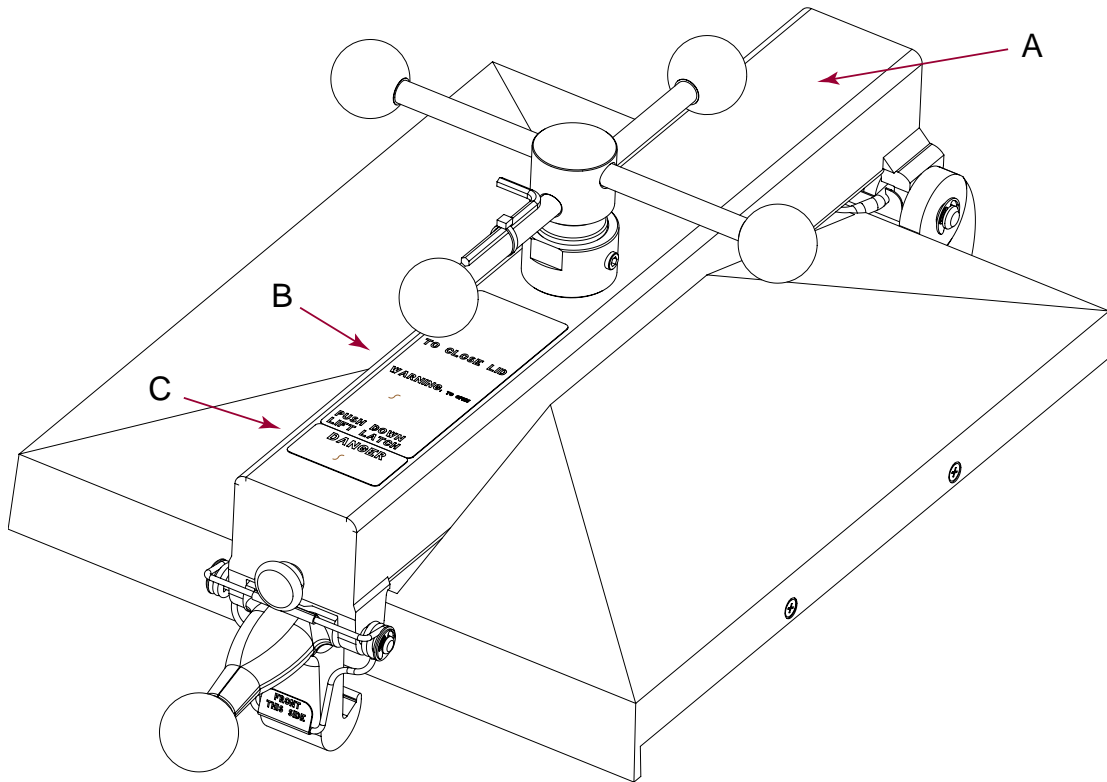

Figure 3-11 Complete Lid w/ Crossbar Assembly (with Language Specific Labels)

NOTE: A, B, C columns below are labels only as reflected in the [Figure 3-11 Complete Lid w/ Crossbar Assembly \(with Language Specific Labels\)](#), page 110.

			PART (A)	PART (B)	PART (C)
PART NUMBER	DESCRIPTION	LANGUAGE	Center Bar Assembly	Lid Operating Instructions	Danger
154867-001	ASSY., LID W/ LABELS	ENGLISH - UL	48611	16181	36099
154867-002	ASSY., LID W/ LABELS	ENGLISH/ FRENCH - UL	48611	16181 & 70920	70919
154867-003	ASSY., LID W/ LABELS	ENGLISH/ SPANISH - UL	48611	16181 & 48666	44884
154867-004	ASSY., LID W/ LABELS	ENGLISH - CE	26885	16181	36099

			PART (A)	PART (B)	PART (C)
PART NUMBER	DESCRIPTION	LANGUAGE	Center Bar Assembly	Lid Operating Instructions	Danger
154867-005	ASSY., LID W/ LABELS	ARABIC - CE	26885	96901	96902
154867-006	ASSY., LID W/ LABELS	BULGARIAN - CE	26885	93682	93674
154867-007	ASSY., LID W/ LABELS	CROATION - CE	26885	95067	95068
154867-008	ASSY., LID W/ LABELS	CZECH - CE	26885	68279	68271
154867-009	ASSY., LID W/ LABELS	DANISH - CE	26885	61044	61033
154867-010	ASSY., LID W/ LABELS	DUTCH - CE	26885	61072	61067
154867-011	ASSY., LID W/ LABELS	ESTONIAN - CE	26885	67781	67778
154867-012	ASSY., LID W/ LABELS	FINNISH - CE	26885	61567	61289
154867-013	ASSY., LID W/ LABELS	FRENCH - CE	26885	48694	44885
154867-014	ASSY., LID W/ LABELS	GERMAN - CE	26885	18643	34477
154867-015	ASSY., LID W/ LABELS	GREEK - CE	26885	61564	61396
154867-016	ASSY., LID W/ LABELS	HUNGARIAN - CE	26885	70536	97196
154867-017	ASSY., LID W/ LABELS	ITALIAN - CE	26885	61565	61362
154867-018	ASSY., LID W/ LABELS	LATVIAN - CE	26885	68468	68470
154867-019	ASSY., LID W/ LABELS	LITHUANIAN - CE	26885	68280	68272
154867-020	ASSY., LID W/ LABELS	NORWEGIAN - CE	26885	67745	67742
154867-021	ASSY., LID W/ LABELS	POLISH - CE	26885	46994	86487
154867-022	ASSY., LID W/ LABELS	PORTUGUESE - CE	26885	61563	61255

			PART (A)	PART (B)	PART (C)
PART NUMBER	DESCRIPTION	LANGUAGE	Center Bar Assembly	Lid Operating Instructions	Danger
154867-023	ASSY., LID W/ LABELS	SCHI - CE	26885	77422	77429
154867-024	ASSY., LID W/ LABELS	SLOVAK - CE	26885	74003	97197
154867-025	ASSY., LID W/ LABELS	SPANISH - CE	26885	48666	44884
154867-026	ASSY., LID W/ LABELS	SWEDISH - CE	26885	61566	61322

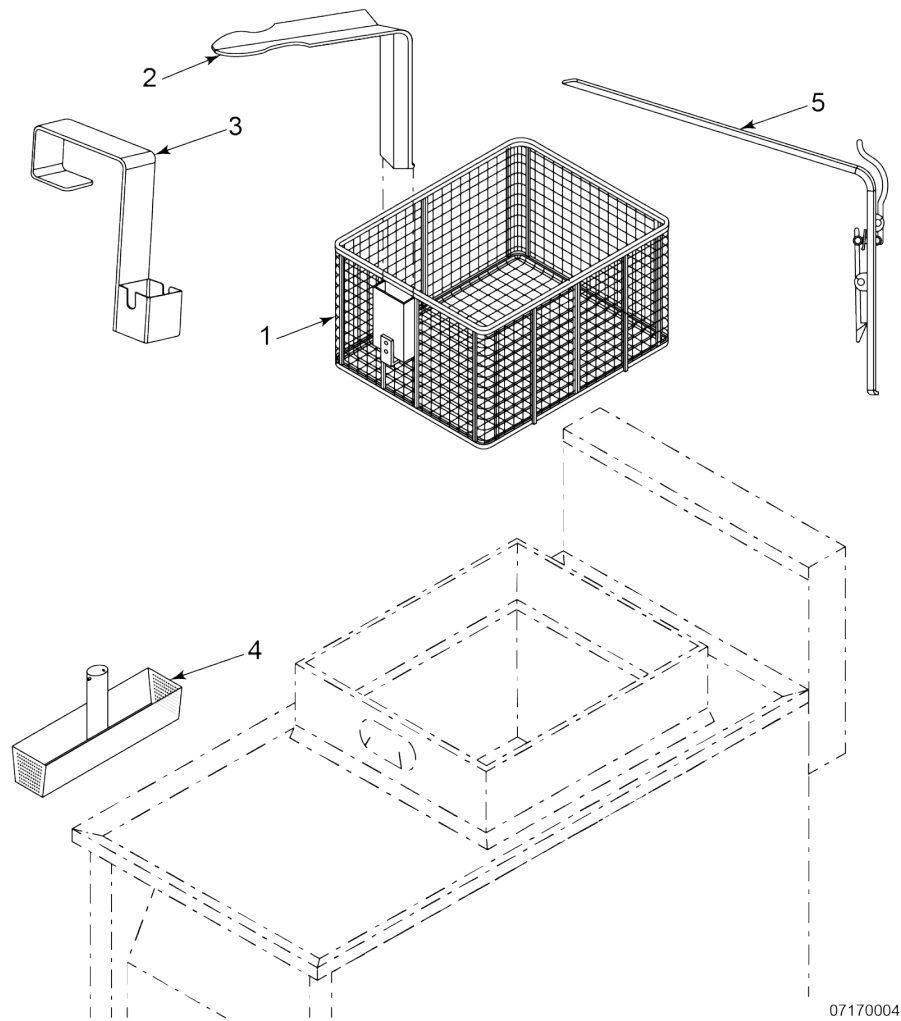

07170004

Figure 3-12 Fry Basket

Item No.	Part No.	Description	Qty.
* Not Shown			
1	17801	BASKET, W/O LEGS - GAS MODEL ONLY	1
2	165801	HANDLE	1
3	24438	ASSY., WELD-CRUMB BASKET HANDLE	1
4	03397	ASSY., WELD-CRUMB PAN/TUBE - PFG-600 W/ HANDLE	1
5	64071	HANDLE, LOCKING ASSEMBLY	1
6*	19535	SUPPORT, 1/2 SIZE BASKET - MODEL 600	1
7*	19509	BASKET, 1/2 SIZE - MODEL 600	2
7*	72009	BASKET, CHICKEN FILET (McDs) - MODEL 600	1
8*	72294	INSERT, DROP-IN FILLET BASKET (McDs)	1
9*	19545	BASKET, BIG BIRD (KFC) - MODEL 600	1

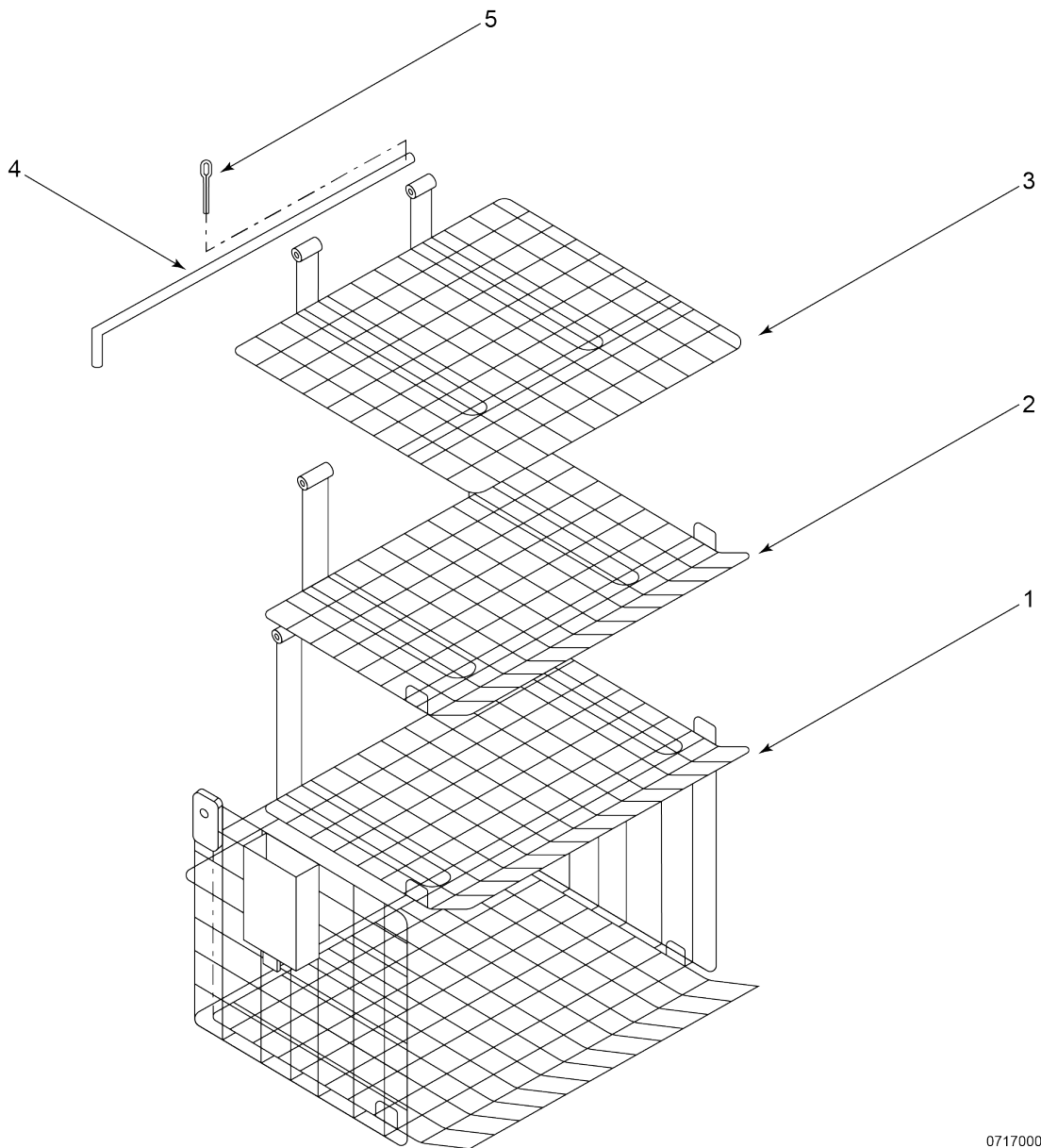

07170002

Figure 3-13 3 Tier Wire Basket

Item No.	Part No.	Description	Qty.
-	64058	BASKET, STAINLESS STEEL	1
1	64060	- SHELF, 2ND	1
2	64061	- SHELF, 3RD	1

<b>Item No.</b>	<b>Part No.</b>	<b>Description</b>	<b>Qty.</b>
3	64062	- COVER	1
4	19536	- ROD, PIVOT	1
5	PN01-001	- PIN, COTTER	1

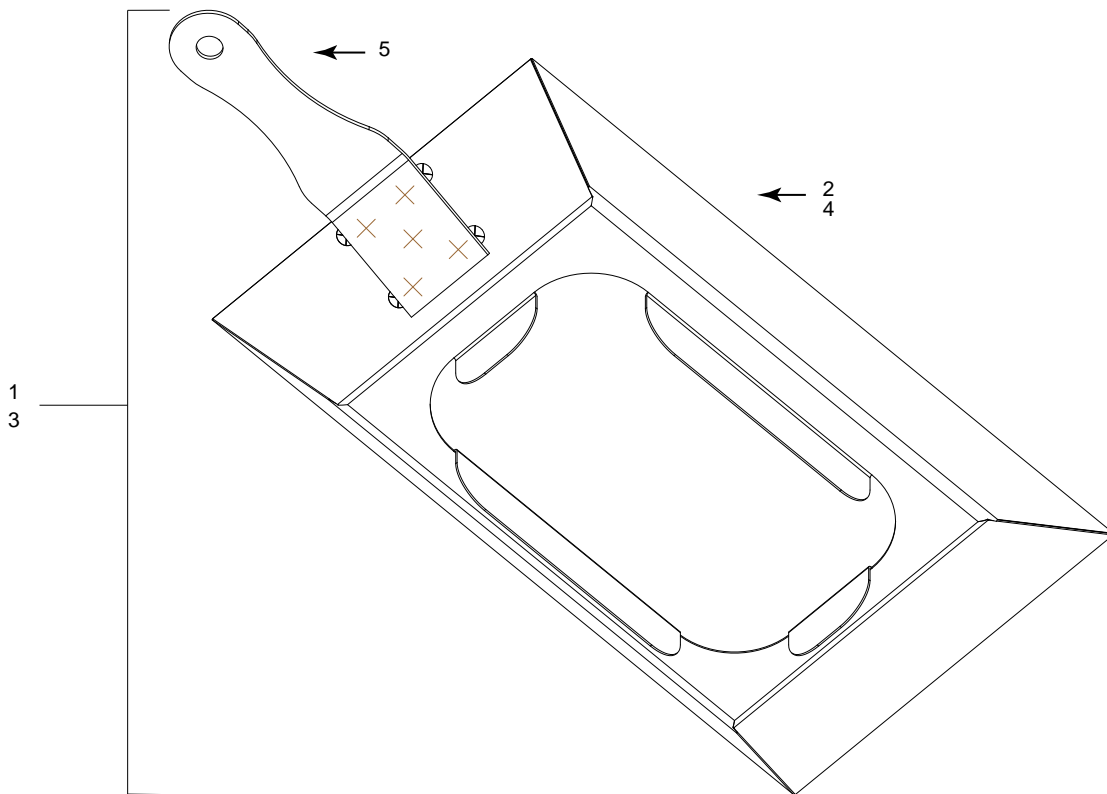
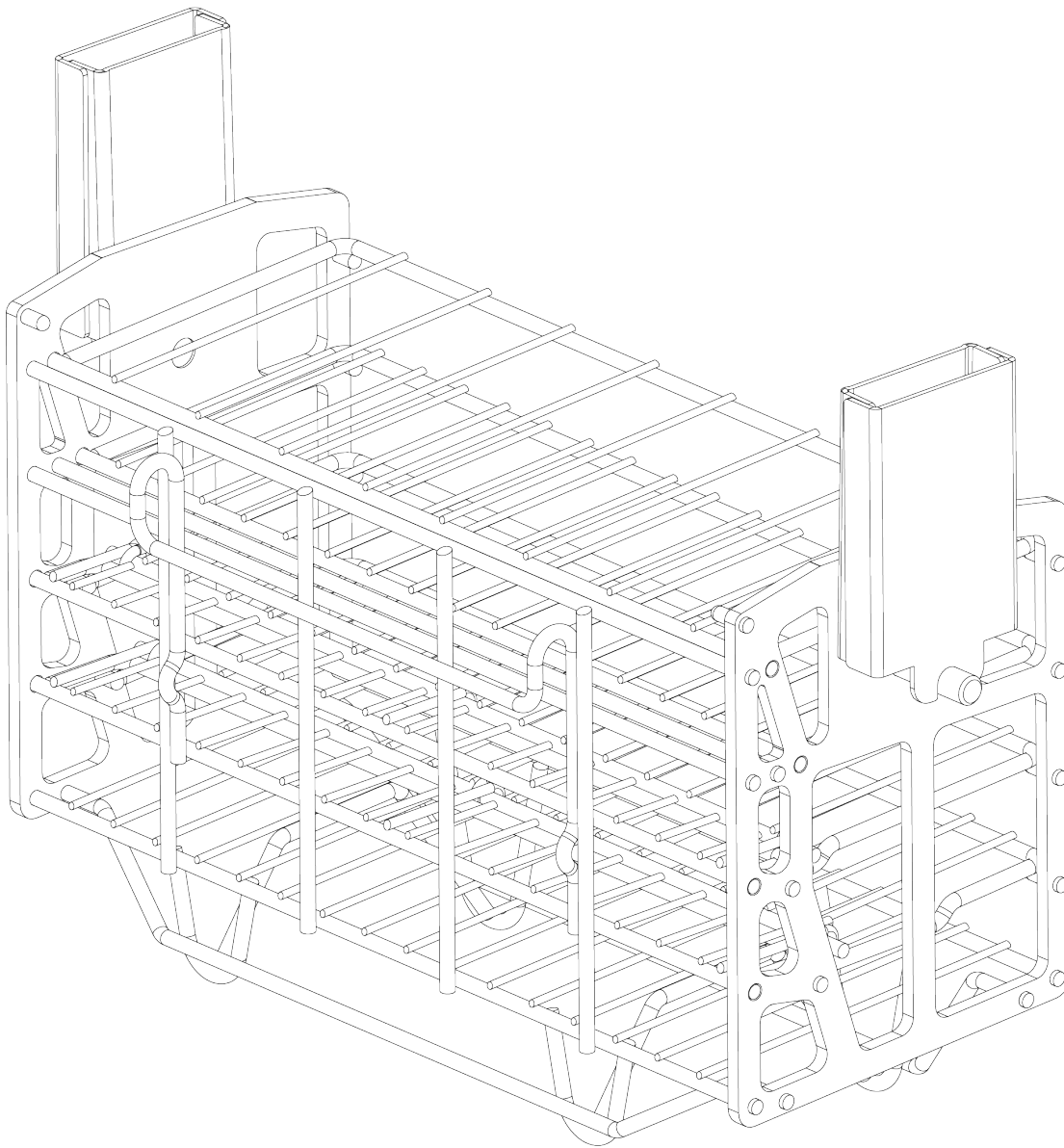

Figure 3-14 CFA Half-Quarter Size Funnels

Item No.	Part No.	Description	Qty.
1	168347	ASSY., FUNNEL CFA HALF SIZE (NARROW)	1
2	168348	- FUNNEL, CFA HALF SIZE (NARROW)	1
3	168351	ASSY., FUNNEL CFA QUARTER	1
4	168352	- FUNNEL, CFA QUARTER SIZE	1
5	162234	HANDLE, CFA FUNNEL	1



**Figure 3-15 CFA Double Hinged Basket**

Item No.	Part No.	Description	Qty.
1	168952	BASKET, TIERED 4HD DOUBLE HINGED	1

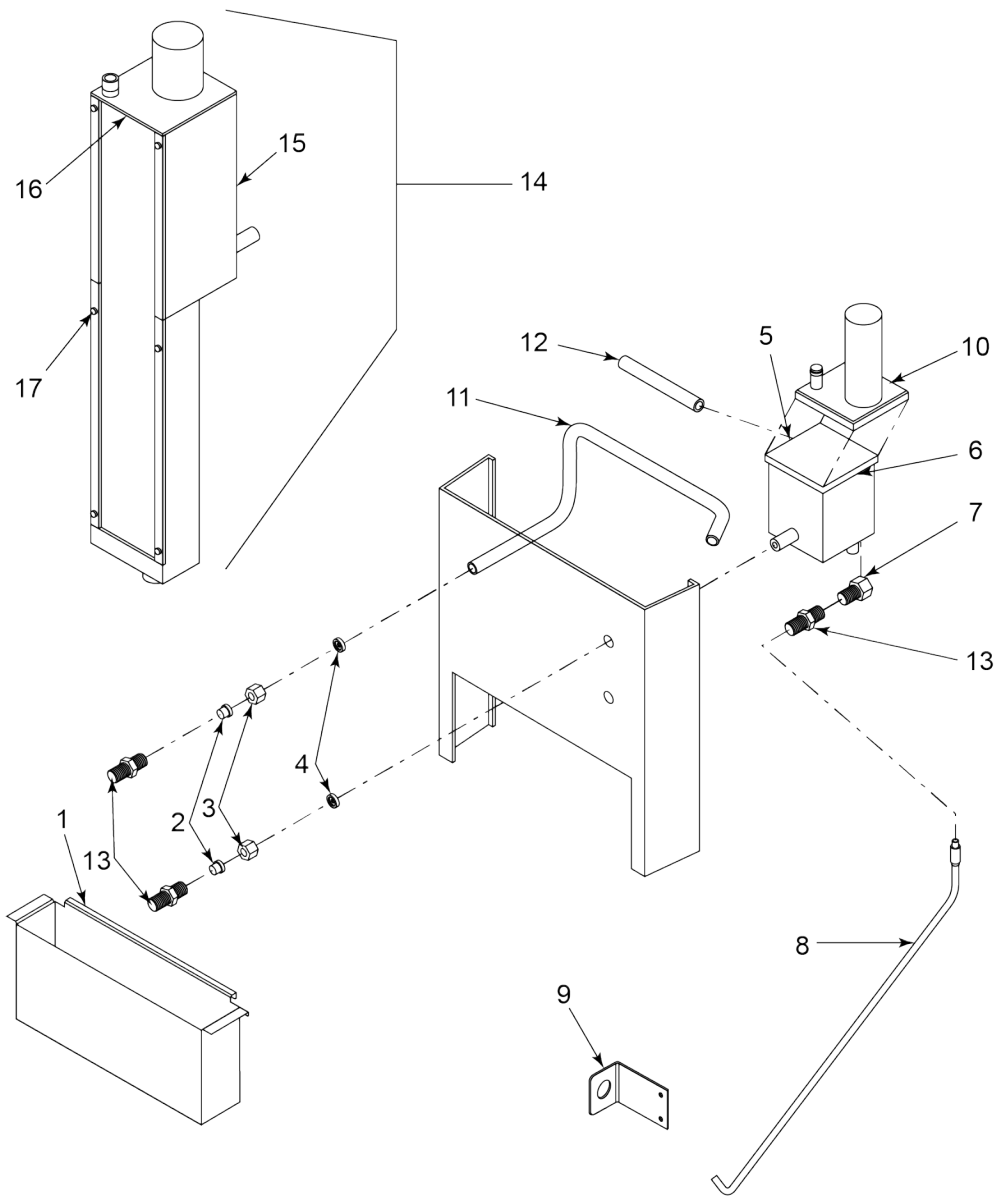

07170006

Figure 3-16 Exhaust Stack Assembly

Item No.	Part No.	Description	Qty.
1	68086	PAN, CONDENSATE DRAIN	1
1	64274	PAN, CONDENSATE DRAIN - SHORT (CFA - JB095JA TO HB013JB)	1
2	16817	FITTING, TEFLON SLEEVE	2

Item No.	Part No.	Description	Qty.
3	16809	NUT, FITTING	2
4	16804	GROMMET, UMBRELLA	2
5	USE 65724	CONDENSATE BOX, BOTTOM (EB016JB TO HB013JB (EXCEPT EB018JB & EB019HB))	-
5	USE 65724	CONDENSATE BOX, BOTTOM (EB020JB TO HB016JB)	-
5	USE 65724	CONDENSATE BOX, BOTTOM (EA015JB TO GA085JB)	1
6	SC02-016	SCREW, #8-32-AB X 1/2 PH PHD S	4
7	FP01-122	REDUCER, 3/8 TO 1/2 BI	1
8	18506	LINE ASSY., CONDENSATION (KB020JJ & BELOW)	-
8	55432	LINE ASSY., CONDENSATION (KB029JJ & BELOW)	-
8	16838	LINE ASSY., CONDENSATION (KA020JJ & BELOW)	1
8	14320	LINE ASSY., CONDENSATION (KB021JJ TO BB016JA)	-
8	14320	LINE ASSY., CONDENSATION (KB030JJ TO BB055JA)	-
8	14320	LINE ASSY., CONDENSATION (KA021JJ TO BA026JA)	1
8	64016	LINE ASSY., CONDENSATION (BB017JA TO EB015JB)	-
8	64016	LINE ASSY., CONDENSATION (BB056JA TO EB019JB)	-
8	64016	LINE ASSY., CONDENSATION (BA027JA TO EA014JB)	1
8	24998	LINE ASSY., CONDENSATION (EB016JB TO HB013JB (EXCEPT EB018JB & EB019HB))	-
8	24998	LINE ASSY., CONDENSATION (EB020JB TO HB016JB)	-
8	24998	LINE ASSY., CONDENSATION (EA015JB TO GA085JB)	1
8	69009	LINE ASSY., CONDENSATION (HB014JB & ABOVE)	-
8	69009	LINE ASSY., CONDENSATION (HB017JB & ABOVE)	-
8	69009	LINE ASSY., CONDENSATION (GA086JB & ABOVE)	1
9	63992	BRACKET, CONDENSATION HOSE	1
10	64013	CONDENSATE BOX, TOP (KB021JJ TO BB016JA)	-
10	64013	CONDENSATE BOX, TOP (KB030JJ TO BB055JA)	-
10	64013	CONDENSATE BOX, TOP (KA021JJ TO BA026JA)	1
10	64013	CONDENSATE BOX, TOP (BB017JA TO EB015JB)	-

Item No.	Part No.	Description	Qty.
10	64013	CONDENSATE BOX, TOP (BB056JA TO EB019JB)	-
10	64013	CONDENSATE BOX, TOP (BA027JA TO EA014JB)	1
10	USE 65724	CONDENSATE BOX, TOP (EB016JB TO HB013JB (EXCEPT EB018JB & EB019HB))	-
10	USE 65724	CONDENSATE BOX, TOP (EB020JB TO HB016JB)	-
10	USE 65724	CONDENSATE BOX, TOP (EA015JB TO GA085JB)	1
11	16854	TUBE SS, DEAD WEIGHT (KA020JJ & BELOW)	1
11	59221	TUBE SS, DEAD WEIGHT (KB021JJ TO BB016JA)	-
11	59221	TUBE SS, DEAD WEIGHT (KB030JJ TO BB055JA)	-
11	59221	TUBE SS, DEAD WEIGHT (KA021JJ TO BA026JA)	1
11	59221	TUBE SS, DEAD WEIGHT (BB017JA TO EB015JB)	-
11	59221	TUBE SS, DEAD WEIGHT (BB056JA TO EB019JB)	-
11	59221	TUBE SS, DEAD WEIGHT (BA027JA TO EA014JB)	1
11	65621	TUBE SS, DEAD WEIGHT (EB016JB TO HB013JB (EXCEPT EB018JB & EB019HB))	-
11	65621	TUBE SS, DEAD WEIGHT (EB020JB TO HB016JB)	-
11	65621	TUBE SS, DEAD WEIGHT (EA015JB TO GA085JB)	1
11	65621	TUBE SS, DEAD WEIGHT (HB014JB & ABOVE)	-
11	65621	TUBE SS, DEAD WEIGHT (HB017JB & ABOVE)	-
11	65621	TUBE SS, DEAD WEIGHT (GA086JB & ABOVE)	1
12	63195	FLEX HOSE, TO CONDUIT BOX (KB021JJ TO BB016JA)	-
12	63195	FLEX HOSE, TO CONDUIT BOX (KB030JJ TO BB055JA)	-
12	63195	FLEX HOSE, TO CONDUIT BOX (KA021JJ TO BA026JA)	1
12	63195	FLEX HOSE, TO CONDUIT BOX (BB017JA TO EB015JB)	-
12	63195	FLEX HOSE, TO CONDUIT BOX (BB056JA TO EB019JB)	-
12	63195	FLEX HOSE, TO CONDUIT BOX (BA027JA TO EA014JB)	1
12	52124	FLEX HOSE, TO CONDUIT BOX (EB016JB TO HB013JB (EXCEPT EB018JB & EB019HB))	-
12	52124	FLEX HOSE, TO CONDUIT BOX (EB020JB TO HB016JB)	-

Item No.	Part No.	Description	Qty.
12	52124	FLEX HOSE, TO CONDUIT BOX (EA015JB TO GA085JB)	1
12	52124	FLEX HOSE, TO CONDUIT BOX (HB014JB & ABOVE)	-
12	52124	FLEX HOSE, TO CONDUIT BOX (HB017JB & ABOVE)	-
12	52124	FLEX HOSE, TO CONDUIT BOX (GA086JB & ABOVE)	1
13	16807	CONNECTOR, MALE	3
14	58852	CONDENSATE BOX (KB021JJ TO BB016JA)	-
14	58852	CONDENSATE BOX (KB030JJ TO BB055JA)	-
14	58852	CONDENSATE BOX (KA021JJ TO BA026JA)	1
14	58852	CONDENSATE BOX (BB017JA TO EB015JB)	-
14	58852	CONDENSATE BOX (BB056JA TO EB019JB)	-
14	58852	CONDENSATE BOX (BA027JA TO EA014JB)	1
14	USE 65724	CONDENSATE BOX (EB016JB TO HB013JB (EXCEPT EB018JB & EB019HB))	-
14	USE 65724	CONDENSATE BOX (EB020JB TO HB016JB)	-
14	USE 65724	CONDENSATE BOX (EA015JB TO GA085JB)	1
14	65724	CONDENSATE BOX (HB014JB & ABOVE)	-
14	65724	CONDENSATE BOX (HB017JB & ABOVE)	-
14	65724	CONDENSATE BOX (GA086JB & ABOVE)	1
15	65725	- WELD ASSY., STEAM BOX - OUTER	1
16	65726	- WELD ASSY., STEAM BOX - INNER	1
17	SC04-003	- SCREW, #8-32 X 3/8 PH PHD S	6

# NOTICE

Turn safety relief valve toward rear of fryer.

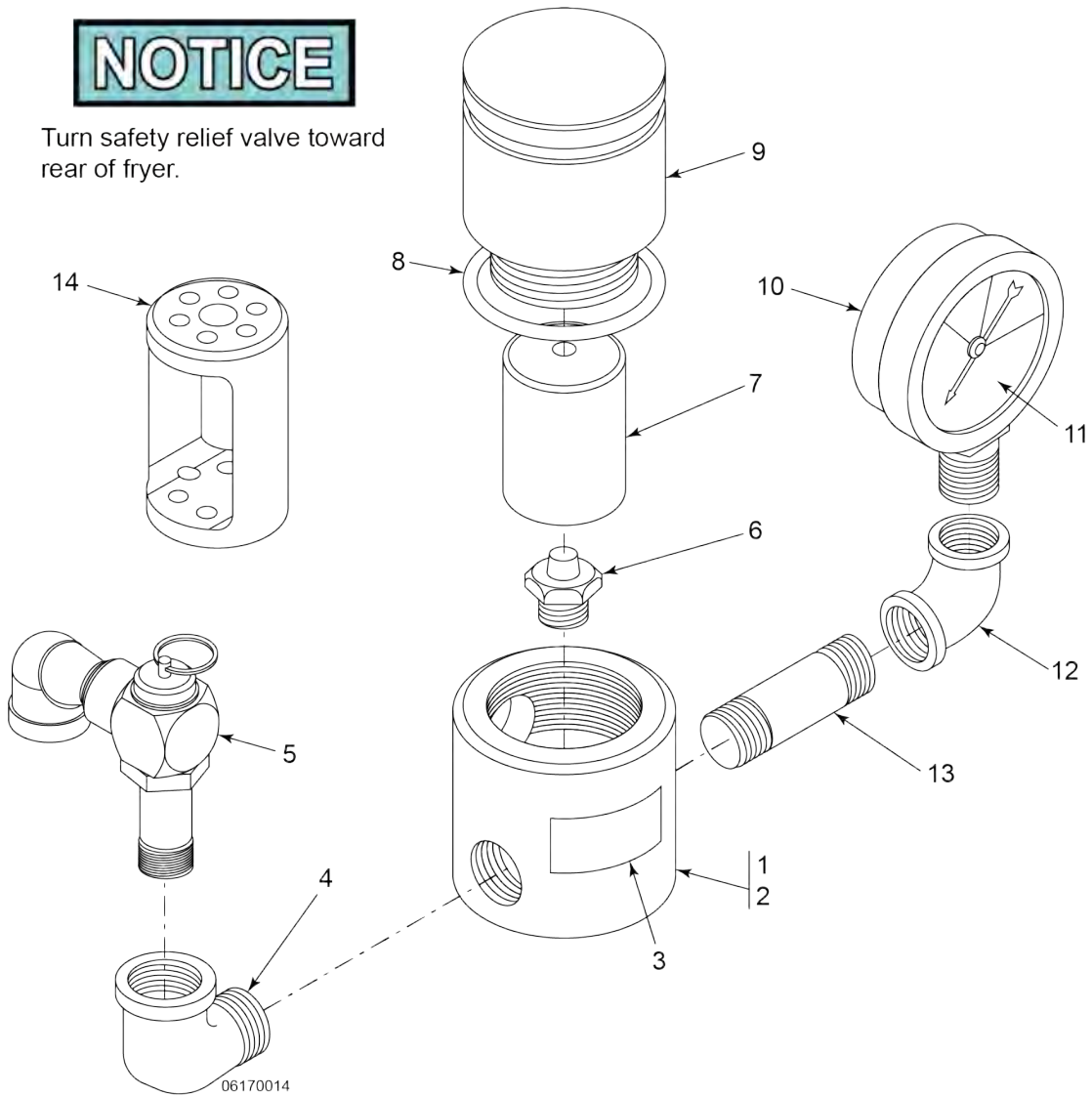

Figure 3-17 Deadweight Valve Assembly

Item No.	Part No.	Description	Qty.
Recommended Parts * Not Shown			
1	16924	VALVE ASSEMBLY, DEADWEIGHT	1
2	56305	- BODY, DEADWEIGHT VALVE	1
3	16912	- DECAL, DEADWEIGHT VALVE	1
4	FP01-127	- ELBOW, 1/2 X 1/2 90 DEGREE STREET	1

Item No.	Part No.	Description	Qty.
5	59742	- VALVE ASSEMBLY, RELIEF	1
6	16918	- ORIFICE, DEADWEIGHT	1
6	27910	- ORIFICE, DEADWEIGHT - 3 LB. (USE W/ 28922)	1
7	28922	- DEADWEIGHT - 3 LB. (USE W/ 27910)	1
7	16903	- DEADWEIGHT - 12 LB.	1
7	81343	- DEADWEIGHT - 11 LB. (MALAYSIA)	1
7	32729	- DEADWEIGHT - 7 LB.	1
8	16902	- RING, CAP	1
9	56307	- CAP, DEADWEIGHT VALVE	1
10	16910	GAUGE, PRESSURE	1
11	16914	GLASS, PRESSURE GAUGE	1
12	16909	ELBOW	1
13	56636	NIPPLE	1
14	65449	DEADWEIGHT - 3 LB.	1
15*	140463	KIT, PRESSURE TEST GAUGE	1

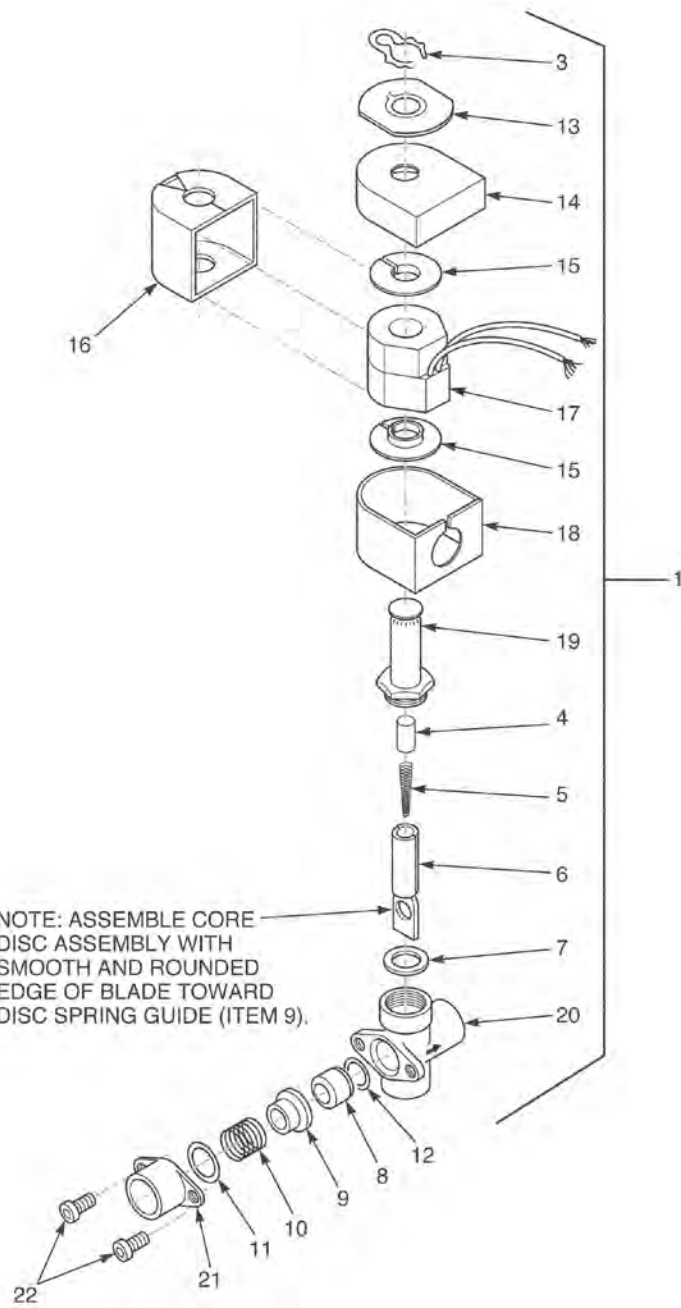
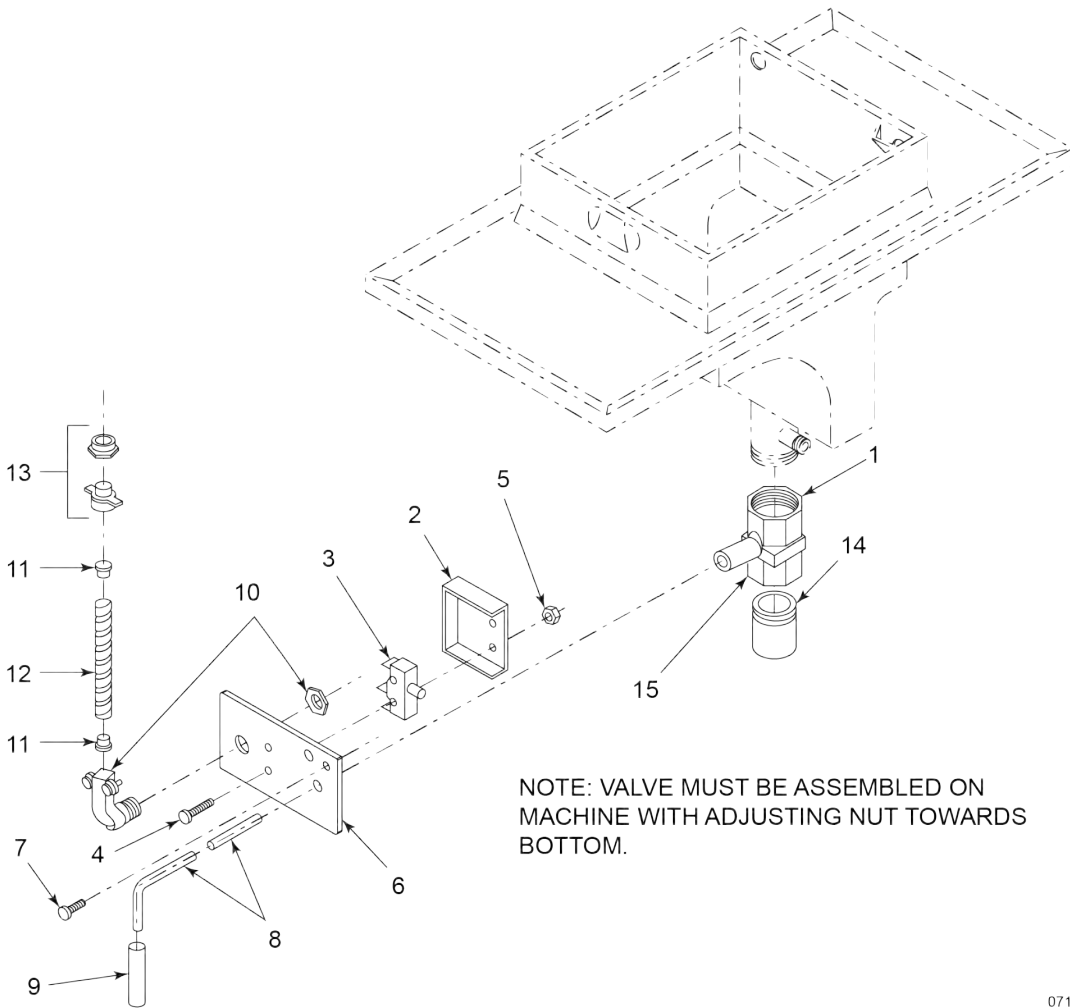

Figure 3-18 Solenoid Valve Assembly

Item No.	Part No.	Description	Qty.
Recommended Parts * Not Shown			
1	17121	VALVE, SOLENOID - 120 VOLT - 60 CYCLE	1
1	18724	VALVE, SOLENOID - 208-240 VOLT - 50 CYCLE	1
1	18721	VALVE, SOLENOID - 208/240 VOLT - 60 CYCLE	1
1	29515	VALVE, SOLENOID - 24 VOLT - 60 CYCLE	1
1	29698	VALVE, SOLENOID - 24 VOLT - 50 CYCLE	1
1	54945	VALVE, SOLENOID - 208-240 VOLT - 50 CYCLE - (CE)	1
1	54971	VALVE, SOLENOID - 24 VOLT - 50 CYCLE - (CE)	1
2	17120	- KIT, SOLENOID VALVE REPAIR	1
3	17101	- CLIP, RETAINING	1
4	17109	- RETAINER, SPRING	1
5	17110	- SPRING, CORE	1
6	17111	- CORE, DISC ASSEMBLY	1
7	17112	- GASKET, BONNET	1
8	17114	- SEAT, TEFLON	1
9	17115	- GUIDE, DISC SPRING	1
10	17116	- SPRING, DISC	1
11	17117	- RING, SPRING RETAINER	1
12	17122	- SEAT, O-RING SEAL	1
13	17102	- PLATE, SOLENOID NAME	1
14	17103	- COVER, COIL HOUSING	1
15	17104	- WASHER, COIL	2
16	17105	- YOKE, COIL	1
17	17106	- COIL, 120 VOLT - 60 CYCLE	1
17	18706	- COIL, 208/240 VOLT - 60 CYCLE	1
17	18726	- COIL, 208-240 VOLT - 50 CYCLE	1
17	29547	- COIL, 24 VOLT - 60 CYCLE	1
17	29575	- COIL, 24 VOLT - 50 CYCLE	1

Item No.	Part No.	Description	Qty.
18	17123	- HOUSING, COIL	1
19	17108	- BONNET, SOLENOID	1
20	17113	- BODY, SOLENOID VALVE	1
21	17118	ADAPTER, PIPE	1
22	SC01-132	SCREW, ADAPTER	2



07170007

**Figure 3-19 Drain Valve Assembly**

Item No.	Part No.	Description	Qty.
Recommended Parts * Not Shown			
1	17261	BODY, DRAIN VALVE (JUNE 1998 & ABOVE)	1
1	55152	ASSY., DRAIN VALVE & COUPLING (MAY 1998 & BELOW)	1
2	17210	COVER, MICROSWITCH	1
3	18227	MICROSWITCH	1
4	SC01-058	SCREW, MICROSWITCH	2

Item No.	Part No.	Description	Qty.
5	NS02-005	NUT, MICROSWITCH	2
6	17211	BRACKET, DRAIN - VALVE ROD	1
7	SC03-005	SCREW, DRAIN BRACKET	2
8	17254	ROD, DRAIN VALVE - NORMALLY CLOSED	1
8	67661	ROD, DRAIN VALVE - NORMALLY OPEN	1
9	16293	COVER, VALVE HANDLE	1
10	18644	CONNECTOR 90° FLEXIBLE CONDUIT (INCLUDES NUT)	1
11	18105	INSULATOR	2
12	17214	CONDUIT, FLEXIBLE	1
13	18111	CONNECTOR, FLEXIBLE CONDUIT (INCLUDES NUT)	1
14	18819	EXTENSION NIPPLE (KA020JJ & BELOW)	1
14	18817	EXTENSION NIPPLE (KA021JJ TO GA085JB)	1
14	24647	EXTENSION & DEFLECTOR (GA086JB & ABOVE)	1
15	17255	PIN, COTTER	2
16*	14652	KIT, PFG-600 NORM OPEN DRAIN SWITCH	1

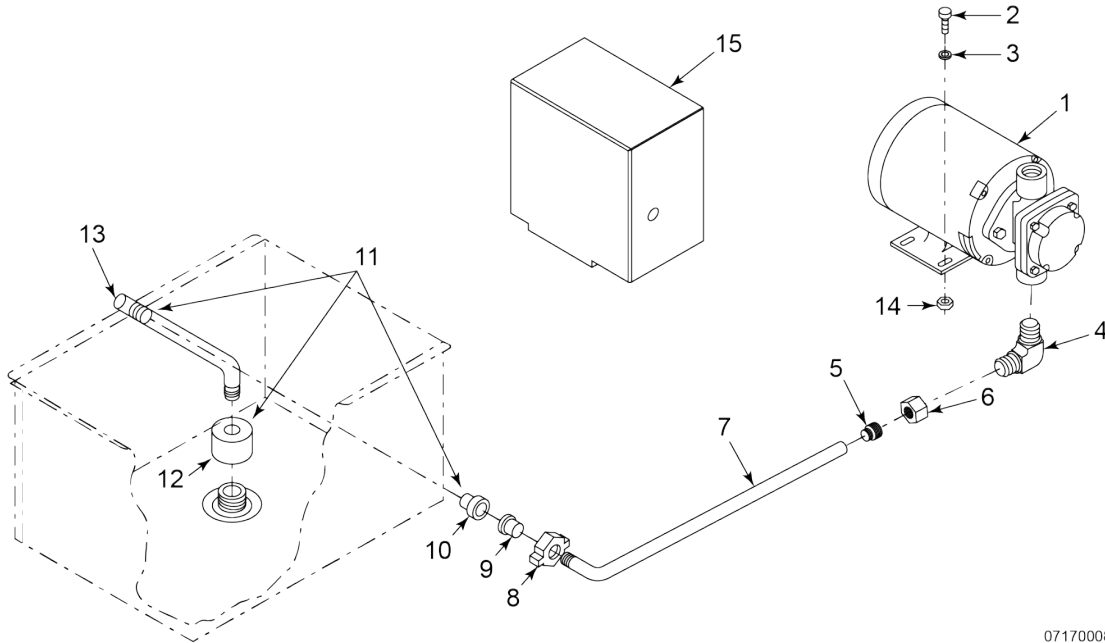

07170008

**Figure 3-20 Lower Filter Plumbing Components**

Item No.	Part No.	Description	Qty.
Recommended Parts * Not Shown			
1	67589	PUMP, FILTER MOTOR	1
1	67583	- MOTOR ONLY, 1/2 HORSE POWER	1
1	17437	- PUMP ONLY	1
1	17476	- KIT, SEAL - PUMP	1
2	SC01-022	SCREW, MOTOR	8
3	WA01-002	WASHER	8
4	17407	CONNECTOR, MALE ELBOW	1
5	16808	FITTING, SLEEVE	1
6	16809	NUT, FITTING	1
7	16812 (INCLUDES 16808 & 16809)	ASSY., PUMP RETURN TUBE (KB020JJ & BELOW)	-

Item No.	Part No.	Description	Qty.
7	64331 (USE IF PAN HAS COVER)	ASSY., PUMP RETURN TUBE (KB020JJ & BELOW)	-
7	16812 (INCLUDES 16808 & 16809)	ASSY., PUMP RETURN TUBE (KB029JJ & BELOW)	-
7	64331 (USE IF PAN HAS COVER)	TUBE, PAN RETURN (KB029JJ & BELOW)	-
7	16812 (INCLUDES 16808 & 16809)	ASSY., PUMP RETURN TUBE (KA020JJ & BELOW)	1
7	64331 (USE IF PAN HAS COVER)	TUBE, PUMP RETURN TUBE (KA020JJ & BELOW)	1
7	58877	TUBE, PUMP RETURN TUBE (KB021JJ TO HB013JB)	-
7	58877	TUBE, PUMP RETURN TUBE (KB030JJ TO HB016JB)	-
7	58877	TUBE, PUMP RETURN TUBE (KA021JJ TO GA085JB)	-
7	23800 (INCLUDES 16808 & 16809)	ASSY., PUMP RETURN TUBE (HB014JB & ABOVE)	-
7	23800 (INCLUDES 16808 & 16809)	ASSY., PUMP RETURN TUBE (HB017JB & ABOVE)	-
7	23800 (INCLUDES 16808 & 16809)	ASSY., PUMP RETURN TUBE (GA086JB & ABOVE)	1
8	17432 (USE 69289)	FITTING, UNION HANDLE	1
9	17431 (USE 69289)	FITTING, MALE UNION	1
10	17430 (USE 69289)	FITTING, FEMALE UNION (ALSO INCLUDED WITH ITEM 11)	1

Item No.	Part No.	Description	Qty.
11	19102	STANDPIPE ASSY. (KB020JJ & BELOW)	-
11	19102	STANDPIPE ASSY. (KB029JJ & BELOW)	-
11	17433	STANDPIPE ASSY. (KA020JJ & BELOW)	1
11	14732	STANDPIPE ASSY. (KB021JJ TO HB013JB)	-
11	14732	STANDPIPE ASSY. (KB030JJ TO HB016JB)	-
11	14732	STANDPIPE ASSY. (KA021JJ TO GA085JB)	1
11	14659	STANDPIPE ASSY. (HB014JB & ABOVE)	-
11	14659	STANDPIPE ASSY. (HB017JB & ABOVE)	-
11	14664	STANDPIPE ASSY. (GA086JB & ABOVE)	1
12	65208	- NUT, FILTER SCREEN	1
13	19101	- STANDPIPE, TUBE (KB020JJ & BELOW)	-
13	19101	- STANDPIPE, TUBE (KB029JJ & BELOW)	-
13	55367	- STANDPIPE, TUBE (KA020JJ & BELOW)	1
13	70061	- STANDPIPE, TUBE (KB021JJ TO HB013JB)	-
13	70061	- STANDPIPE, TUBE (KB030JJ TO HB013JB)	-
13	70061	- STANDPIPE, TUBE (KA021JJ TO GA085JB)	1
13	23951	- STANDPIPE, TUBE (HB014JB & ABOVE)	-
13	23951	- STANDPIPE, TUBE (HB017JB & ABOVE)	-
13	24284	- STANDPIPE, TUBE (GA086JB & ABOVE)	1
14	NS02-002	NUT, MOTOR	4
15	55281	SHIELD, MOTOR SPLASH (KB020JJ & BELOW) (CE)	-
15	55281	SHIELD, MOTOR SPLASH SHIELD (KA020JJ & BELOW) (CE)	1
15	59731	SHIELD, MOTOR SPLASH SHIELD (KB021JJ TO HB013JB) (CE)	-
15	59731	SHIELD, MOTOR SPLASH SHIELD (KA021JJ TO GA085JB) (CE)	1
15	24644	SHIELD, MOTOR SPLASH SHIELD (HB014JB & ABOVE) (CE)	-

Item No.	Part No.	Description	Qty.
15	24644	SHIELD, MOTOR SPLASH SHIELD (GA086JB & ABOVE) (CE)	1
16*	14064	KIT, KFC FILTER	1
17*	17225	- GIRD, KFC FILTER	1
18*	17226	- CLIP, FILTER	1
19*	17228	- FITTING, MALE FILTER	1
20*	17229	- FITTING, FEMALE FILTER	1

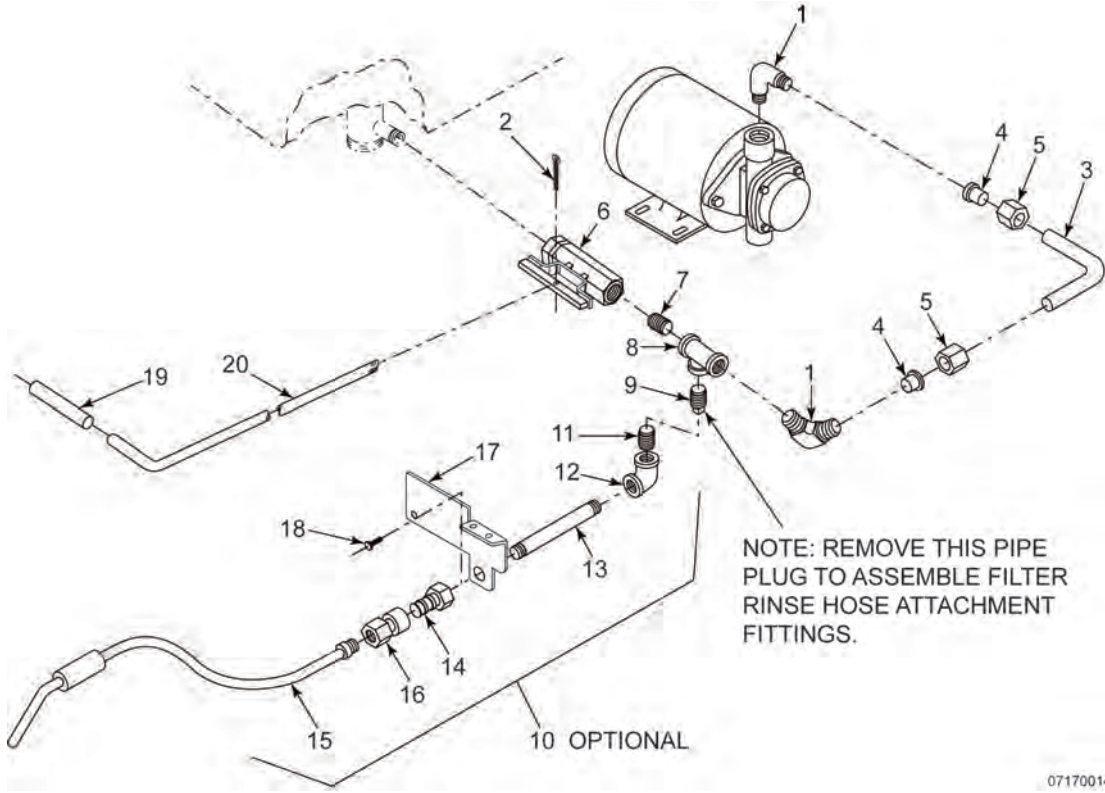

**Figure 3-21 Upper Filter Plumbing Components**

Item No.	Part No.	Description	Qty.
Recommended Parts * Not Shown			
1	17407	CONNECTOR, MALE ELBOW	2
2	17255	PIN, COTTER - VALVE	1
3	18904	TUBE, PUMP TO VALVE (KB020JJ & BELOW)	-
3	44911	TUBE, PUMP TO VALVE (KB029JJ & BELOW)	-
3	17329	TUBE, PUMP TO VALVE (KA020JJ & BELOW)	1
3	63134	TUBE, PUMP TO VALVE (KB021JJ TO HB013JB)	-
3	63134	TUBE, PUMP TO VALVE (KB030JJ TO HB016JB)	-
3	63246	TUBE, PUMP TO VALVE (KA021JJ TO GA085JB)	1
3	27405	TUBE, PUMP TO VALVE (HB014JB & ABOVE)	-

Item No.	Part No.	Description	Qty.
3	26217	TUBE, PUMP TO VALVE (HB017JB & ABOVE)	-
3	27456	TUBE, PUMP TO VALVE (GA086JB & ABOVE)	1
4	16808	- FITTING, SLEEVE	2
5	16809	- NUT, FITTING	2
6	17308	VALVE ASSEMBLY, FILTER	1
7	FP02-001	NIPPLE, CLOSE	1
8	17306	TEE, PIPE	1
9	FP01-015	PLUG, PIPE	1
10	03002	HOSE ASSY., FILTER RINSE OPTIONAL (MODEL 600)	1
11	FP02-007	- NIPPLE, PIPE	1
12	17319	- ELBOW, PIPE	1
13	17320	- PIPE, RINSE HOSE (KB020JJ & BELOW)	-
13	17320	- PIPE, RINSE HOSE (KB029JJ & BELOW)	-
13	17320	- PIPE, RINSE HOSE (KA020JJ & BELOW)	1
13	17320	- PIPE, RINSE HOSE (KB021JJ TO HB013JB)	-
13	17320	- PIPE, RINSE HOSE (KB030JJ TO HB016JB)	-
13	17320	- PIPE, RINSE HOSE (KA021JJ TO GA085JB)	1
13	24982	- PIPE, RINSE HOSE (HB014JB & ABOVE)	-
13	24982	- PIPE, RINSE HOSE (HB017JB & ABOVE)	-
13	24982	- PIPE, RINSE HOSE (GA086JB & ABOVE)	1
14	17334	- FITTING, RINSE HOSE DISCONNECT - MALE	1
15	03003	- HOSE, FILTER RINSE	1
16	17333	- FITTING, RINSE HOSE DISCONNECT - FEMALE	1
17	18419	BRKT, FILTER VALVE & RINSE HOSE (KB020JJ & BELOW)	-
17	44847	BRKT, FILTER VALVE & RINSE HOSE (KB029JJ & BELOW)	-
17	17224	BRKT, FILTER VALVE & RINSE HOSE (KA020JJ & BELOW)	1

Item No.	Part No.	Description	Qty.
17	63193	BRKT, FILTER VALVE & RINSE HOSE (KB021JJ TO HB013JB)	-
17	59958	BRKT, FILTER VALVE & RINSE HOSE (KB030JJ TO HB016JB)	-
17	17224	BRKT, FILTER VALVE & RINSE HOSE (KA021JJ TO GA085JB)	1
17	23917	BRKT, FILTER VALVE & RINSE HOSE (HB014JB & ABOVE)	-
17	23756	BRKT, FILTER VALVE & RINSE HOSE (HB017JB & ABOVE)	-
17	24958	BRKT, FILTER VALVE & RINSE HOSE (GA086JB & ABOVE)	1
18	SC03-005	SCREW, RINSE HOSE BRACKET	2
19	16293	COVER, VALVE ROD	1
20	17311	ROD, FILTER VALVE EXTENSION (MODEL 600)	1
22*	03602	KIT, SHUTTLE CONVERSION (MODEL 600)	1

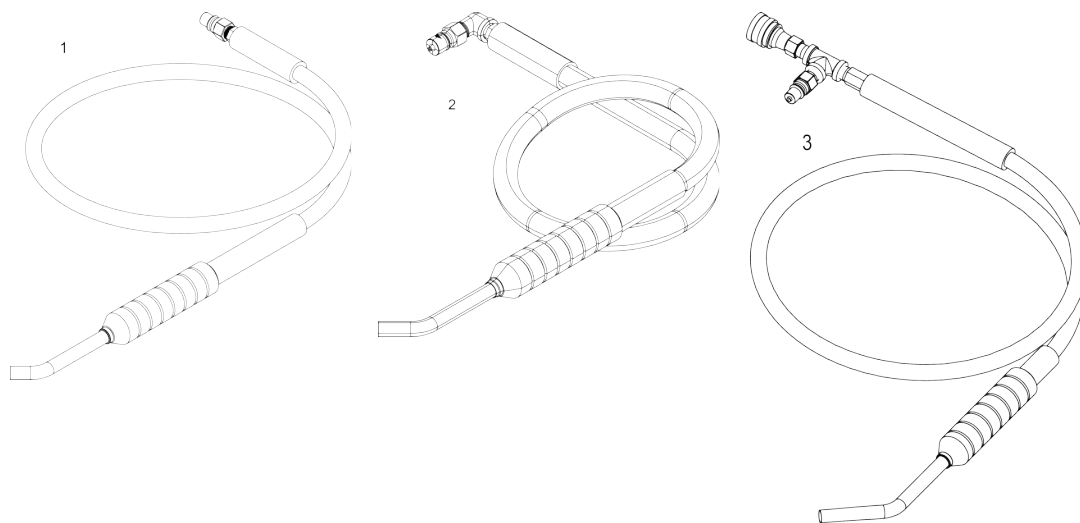
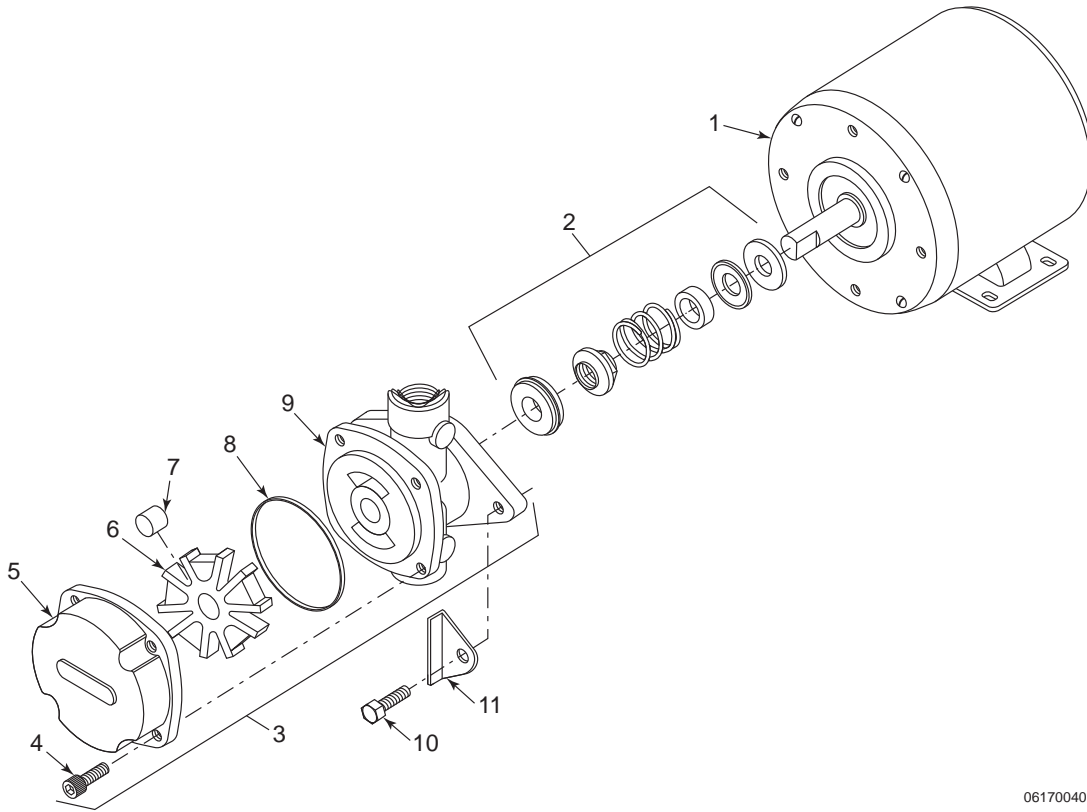

Figure 3-22 Rinse Hose

Item No.	Part No.	Description	500	561
Recommended Parts * Not Shown				
1	165333	HOSE, FILTER RINSE W/ STRAIGHT MALE QUICK DISCONNECT	1	1
2	33494	HOSE, FILTER RINSE W/ 90 DEGREE MALE QUICK DISCONNECT	1	1
3	24904	HOSE, FILTER RINSE W/ 90 DEGREE DUAL GENDER QUICK DISCONNECT	1	1



**Figure 3-23 Filter Motor & Pump**

Item No.	Part No.	Description	Qty.
Recommended Parts			
1	67583	MOTOR, 1/2 HP - 50/60 Hz	1
2	17476	KIT, SEAL	1
3	17437	ASSY., PUMP	1

Item No.	Part No.	Description	Qty.
4	SC01-132	SCREW, PUMP COVER	1
5	17451	COVER, PUMP	1
6	17447	ROTOR, PUMP	1
7	17446	ROLLER, PUMP	5
8	17453	O-RING	1
9	17454	BODY, PUMP	1
10	17456	SHIELD, PUMP	2
11	SC01-026	SCREW, PUMP SHIELD	1

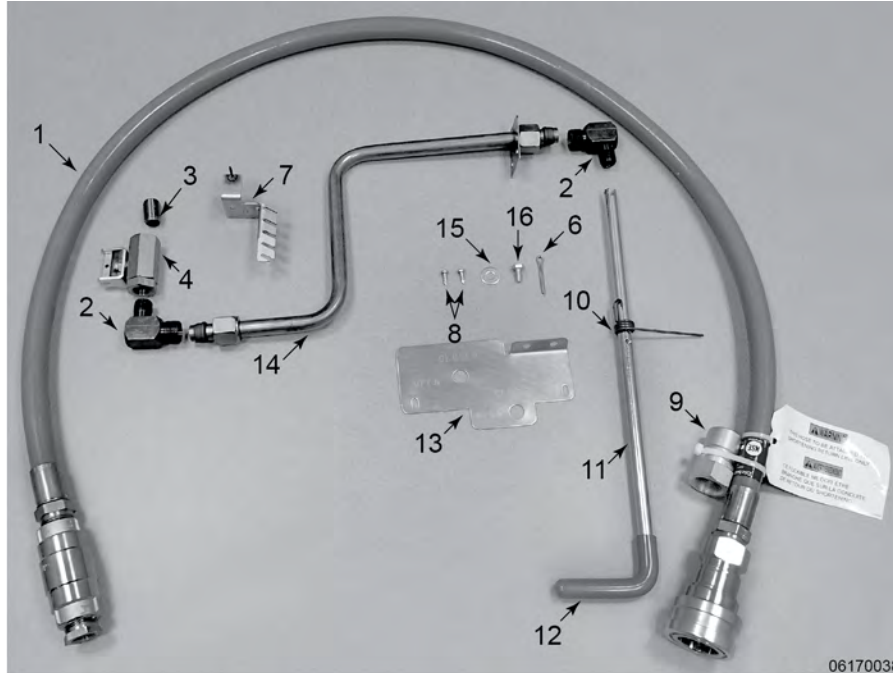

Figure 3-24 Direct-Connect Assembly - Model 600

Item No.	Part No.	Description	Qty.
Recommended Parts * Not Shown			
1	65139	ASSY., DIRECT-CONNECT HOSE	1
2	FP01-079	ELBOW, 5/8 TUBE - 3/8 NPT MALE	2
3	FP02-024	NIPPLE, 3/8 NPT CLOSE BI	1
4	17308	VALVE, FILTER	1
5*	17319	ELBOW, PIPE	1
6	17255	PIN, COTTER	1
7	24641	ASSY., SHORTENING MGT. BRKT	1
8	SC03-005	SCREW, SD #8 X 1/2 PH PHD	2
9	21611	DISCONNECT, MALE	1
10	21874	SPRING, SHORTENING MGT.	1
11	32722	ROD, DIRECT-CONNECT - 600	1
12	29769	GRIP, FRYER HANDLE	1

Item No.	Part No.	Description	Qty.
13	32557	BRACKET, DRAIN ROD - 600	1
14	32648	ASSY., DIRECT-CONNECT TUBE - 600	1
15	WA01-002	WASHER, 1/4 TYPE A-SERIES	1
16	SC01-057	SCREW, 1/4-20 X 1/2 HEX HD	1
17*	14370	KIT, DIRECT-CONNECT (KA020JJ & BELOW)	1
17*	14366	KIT, DIRECT-CONNECT (KA021JJ TO GA085JB)	1
17	14426	KIT, DIRECT-CONNECT (GA086JB & ABOVE)	1

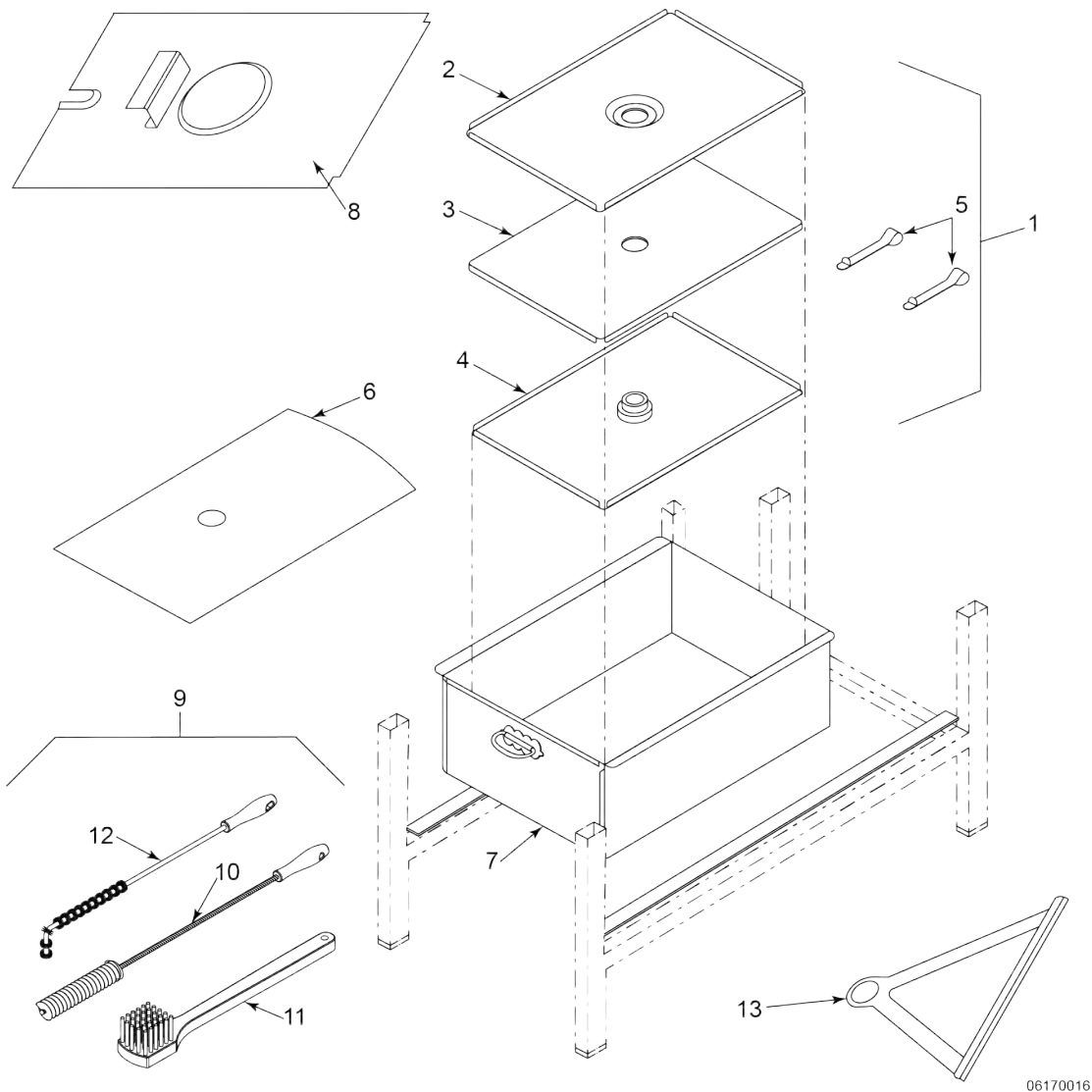

Figure 3-25 Filter Drain Pan & Filter Screen Assembly

Item No.	Part No.	Description	Qty.
Recommended Parts * Not Shown			
1	14671	KIT, GM FILTER SCREEN - SEE <a href="#">Table 3-4 Filter Screen Kits</a> , page 144	1
1	17672	KIT, WENDY'S FILTER SCREENS - SEE <a href="#">Table 3-4 Filter Screen Kits</a> , page 144	1

Item No.	Part No.	Description	Qty.
2	65211	- CATCHER, CRUMB - SS	1
3	NLA	- SCREEN, TOP FILTER	1
4	USE 14671 OR 14672	- SCREEN, BOTTOM FILTER (AN0503086 & BELOW - 600)	1
5	17505	- CLIPS, FILTER ENVELOPE	2
6	12102	FILTER, ENVELOPE PAPER (100 PER CARTON)	1
6	24262	CARBON PAD, FILTER ENVELOPE (30 PER CARTON)	1
6	24263	CARBON, FILTER ENVELOPE (30 PER CARTON)	1
7	19206	PAN, FILTER DRAIN ASSEMBLY (KB020JJ & BELOW)	-
7	19206	PAN, FILTER DRAIN ASSEMBLY (KB029JJ & BELOW)	-
7	17506	PAN, FILTER DRAIN ASSEMBLY (KA020JJ & BELOW)	1
7	58848	PAN, FILTER DRAIN ASSEMBLY (KB021JJ TO BB016JA)	-
7	63203	PAN, FILTER DRAIN ASSEMBLY (KB030JJ TO BB055JA)	-
7	58848	PAN, FILTER DRAIN ASSEMBLY (KA021JJ TO BA026JA)	1
7	64014	PAN, FILTER DRAIN ASSEMBLY (BB017JA TO HB013JB)	-
7	64015	PAN, FILTER DRAIN ASSEMBLY (BB056JA TO HB016JB)	-
7	64014	PAN, FILTER DRAIN ASSEMBLY (BA027JA TO GA085JB)	1
7	24702	PAN, FILTER DRAIN ASSEMBLY (HB014JB & ABOVE)	-
7	24702	PAN, FILTER DRAIN ASSEMBLY (HB017JB & ABOVE)	-
7	17506	PAN, FILTER DRAIN ASSEMBLY (GA086JB & ABOVE)	1
7	23499	PAN, FILTER DRAIN ASSY.. (CFA - JB095JA TO HB013JB)	1
8	18915	COVER, FILTER DRAIN PAN (KB020JJ & BELOW)	-
8	18915	COVER, FILTER DRAIN PAN (KB029JJ & BELOW)	-
8	17512	COVER, FILTER DRAIN PAN (KA020JJ & BELOW)	1
8	64024	COVER, FILTER DRAIN PAN (KB021JJ TO BB016JA)	-
8	64025	COVER, FILTER DRAIN PAN (KB030JJ TO BB055JA)	-

Item No.	Part No.	Description	Qty.
8	64023	COVER, FILTER DRAIN PAN (KA021JJ TO BA026JA)	1
8	64021	COVER, FILTER DRAIN PAN (BB017JA TO HB013JB)	-
8	64022	COVER, FILTER DRAIN PAN (BB056JA TO HB016JB)	-
8	64020	COVER, FILTER DRAIN PAN (BA027JA TO GA085JB)	1
8	68065	COVER, FILTER DRAIN PAN (HB014JB & ABOVE)	-
8	68065	COVER, FILTER DRAIN PAN (HB017JB & ABOVE)	-
8	68066	COVER, FILTER DRAIN PAN (GA086JB & ABOVE)	1
8	32627	COVER, FILTER DRAIN PAN - MALAYSIA	1
8	69296	COVER, STORAGE - PFG-600	1
8	14414	KIT, COVER/DRAIN EXTENSION (KB021JJ TO BB016JA)	-
8	14414	KIT, COVER/DRAIN EXTENSION (KB030JJ TO BB055JA)	-
8	14415	KIT, COVER/DRAIN EXTENSION (BB017JA TO HB013JB)	-
8	14415	KIT, COVER/DRAIN EXTENSION (BB056JA TO HB016JB)	-
9	14461	KIT, BRUSH SET	1
10	12112	- BRUSH, STRAIGHT WHITE	1
11	12116	- BRUSH, FRYER - GONG - LONG HANDLE	1
12	12126	- BRUSH, BLACK L TIPPED	1
13	63102	SEALER BAR, WENDY'S	1
13	62116	SEALER BAR, GENERAL MARKET	1
14*	03387	DOLLY, FILTER PAN (KB020JJ & BELOW)	-
14*	03387	DOLLY, FILTER PAN (KB029JJ & BELOW)	-
14*	03352	DOLLY, FILTER PAN (KA020JJ & BELOW)	1
14*	03389	DOLLY, FILTER PAN (KB021JJ TO BB016JA)	-
14*	03390	DOLLY, FILTER PAN (KB030JJ TO BB055JA)	-
14*	03389	DOLLY, FILTER PAN (KA021JJ TO BA026JA)	1
14*	03391	DOLLY, FILTER PAN (BB017JA TO HB013JB)	-
14*	03392	DOLLY, FILTER PAN (BB056JA TO HB016JB)	-

Item No.	Part No.	Description	Qty.
14*	03391	DOLLY, FILTER PAN (BA027JA TO GA085JB)	1
14*	03343	DOLLY, FILTER PAN (HB014JB & ABOVE)	-
14*	03343	DOLLY, FILTER PAN (HB017JB & ABOVE)	-
14*	03352	DOLLY, FILTER PAN (GA086JB & ABOVE)	1
15*	14895	KIT, SPCL SHORT FLTR KFC/FALCON	1
16*	65208	NUT, FILTER - FEMALE (USE WITH #4 ABOVE)	1

Table 3-4 Filter Screen Kits

	65211	65447	17505	65208	63102
14671-GM	1	1	2	1	-
14672-WENDY'S	-	1	-	1	1

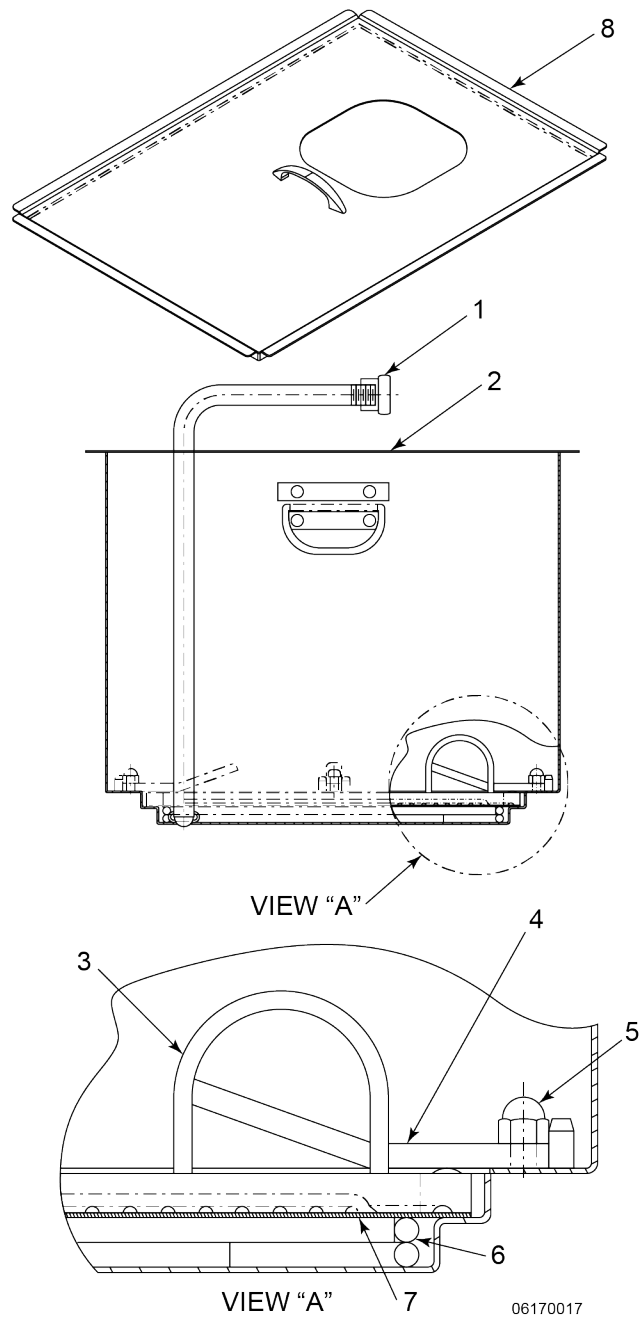

Figure 3-26 Supersorb Filter Assembly (Before 3-1-02)

Item No.	Part No.	Description	500	561
Recommended Parts * Not Shown				
1	17430 (USE 69289)	UNION, FEMALE FITTING	1	1
2	140028	ASSY., FILTER PAN (KB020JJ & BELOW)	1	-
2	140028	ASSY., FILTER PAN (KB029JJ & BELOW)	-	1
2	140034	ASSY., FILTER PAN (KA020JJ & BELOW)	-	-
2	24702	ASSY., FILTER PAN (HB014JB & ABOVE)	1	-
2	24702	ASSY., FILTER PAN (HB017JB & ABOVE)	-	1
2	17506	ASSY., FILTER PAN (GA086JB & ABOVE)	-	-
3	70561	SCREW, FILTER CLAMP RING W/ SCREW	1	1
4	36596	HANDLE, FILTER LOCK	4	4
5	NS03-023	NUT, 1/4-20 ACORN CAP	4	4
6	30944	SUPPORT, FILTER PAD	1	1
7	12186	FILTER PAD, CHARCOAL	1	1
8	54008	COVER, FILTER PAN ASSY. (KB020JJ & BELOW)	1	-
8	54008	COVER, FILTER PAN ASSY. (KB029JJ & BELOW)	-	1
8	54538	COVER, FILTER PAN ASSY. (KA020JJ & BELOW)	-	-
8	24627	COVER, FILTER PAN ASSY. (HB014JB & ABOVE)	1	-
8	24627	COVER, FILTER PAN ASSY. (HB017JB & ABOVE)	-	1
8	68066	COVER, FILTER PAN ASSY. (GA086JB & ABOVE)	-	-
9*	03388	DOLLY, FILTER PAN (4 & 6 HD) (KB020JJ & BELOW)	1	-
9*	03388	DOLLY, FILTER PAN (4 & 6 HD) (KB029JJ & BELOW)	-	1
9*	03388	DOLLY, FILTER PAN (4 & 6 HD) (KA020JJ & BELOW)	-	-
9*	03343	DOLLY, FILTER PAN (4 & 6 HD) (HB014JB & ABOVE)	1	-
9*	03343	DOLLY, FILTER PAN (4 & 6 HD) (HB017JB & ABOVE)	-	1

Item No.	Part No.	Description	500	561
9*	03352	DOLLY, FILTER PAN (4 & 6 HD) (GA086JB & ABOVE)	-	-
10*	19004	CASTERS	4	4
11*	140036	PAN, W/O CASTERS (KB030JJ TO BB055JA)	-	1
11*	140035	PAN, W/O CASTERS (KA021JJ TO BA026JA)	-	-
11*	140037	PAN, W/O CASTERS (BB017JA TO HB013JB)	1	-
11*	140038	PAN, W/O CASTERS (BB056JA TO HB016JB)	-	1
11*	140037	PAN, W/O CASTERS (BA027JA TO GA085JB)	-	-

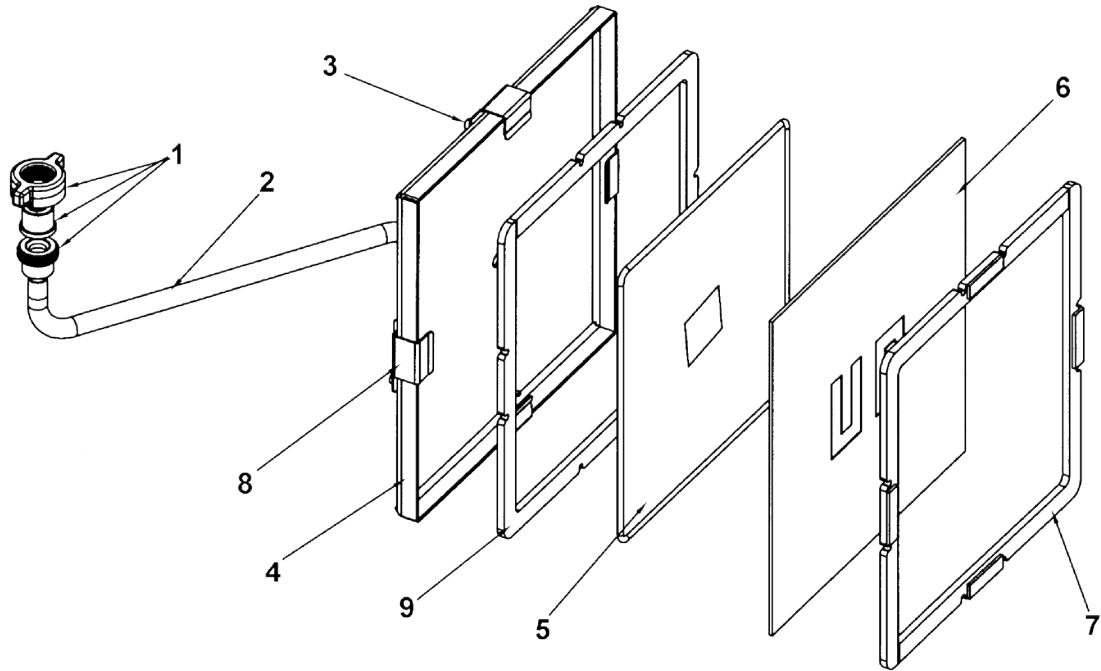
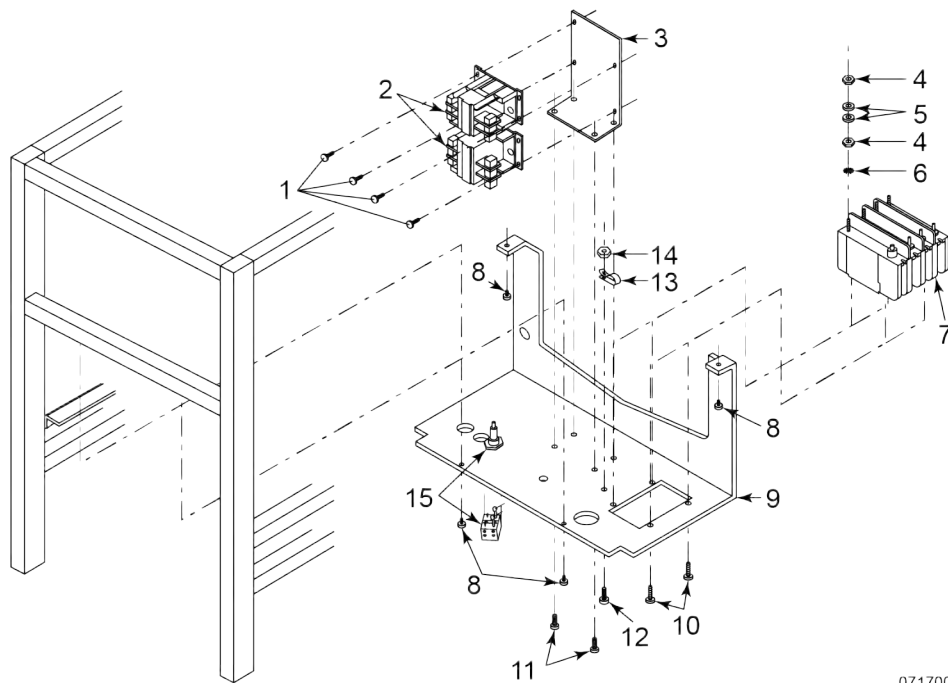

Figure 3-27 Supersorb Filter Assembly (3-1-02 & After)

Item No.	Part No.	Description	Qty.
Recommended Parts: A = Truck Stock; B = Dist. Stock * Not Shown			
1	69289	ASSY., FILTER UNION	1
2	24284	TUBE, D.U. TO FILTER - GAS	1
3	SC01-249	SCREW, 8-32 X 3/16 TH SHOULDER	4
4	67948	WELD ASSY., DRAIN FILTER	1
5	66202	WELD ASSY., FILTER SECTION	1
6	12186	FILTER PAD, CHARCOAL (CARTON OF 30)	1
7	70585	RING, FILTER CLAMP W/O SCREW	1
8	32851	CLIP, SHORT DRAIN FILTER (AN0507126 & ABOVE - 600)	4
8	67952	CLIP, SHORT DRAIN FILTER (AN0507126 & ABOVE - 600)	4

Item No.	Part No.	Description	Qty.
9	70721	RING, FILTER RETAINER WHOLE (AN0507126 & ABOVE - 600)	1
10*	14424	KIT, 600 SUPERSORB ASSY. (INCLUDES 1, 2B, 3-7, 8B, & 9)	1



07170009

Figure 3-28 Contactor & Frame Assembly (Single Phase Electric Model)

Item No.	Part No.	Description	Qty.
Recommended Parts * Not Shown			
1	SC04-003	SCREW	4
2	19405	CONTACTOR	2
2	65074	CONTACTOR, 230 VOLT (CE)	2
3	18243	BRACKET, CONTACTOR	1
4	NS01-014	NUT, HEX	16
5	WA01-007	WASHER	16
6	LW02-005	LOCKWASHER	8
7	18242	BREAKER, CIRCUIT 50 AMP	1
8	SC03-005	SCREW	4
9	18244	SHROUD, SINGLE PHASE (KB0202JJ & BELOW)	1
9	63226	SHROUD, SINGLE PHASE (KB021JJ TO HB013JB)	1
9	27418	SHROUD, SINGLE PHASE (HB014JB & ABOVE)	1

Item No.	Part No.	Description	Qty.
10	SC01-072	SCREW	4
11	SC04-002	SCREW	4
12	SC01-010	SCREW	1
13	EF02-030	CAPILLARY CLAMP	1
14	NS02-005	NUT	1
15	EF02-125	BREAKER, PUSH-BUTTON RESET (10-23-06 & AFTER)	2
15	18364	ASSY., FUSE HOLDER - 15 AMP (BEFORE 10-23-06)	2
15	EF02-007	- FUSE, 15 AMP	2
15	EF02-006	- HOLDER, FUSE	2
16*	14033	KIT, 3 PHASE TO 1 PHASE CONVERSION (KB020JJ & BELOW)	1
16*	14677	KIT, 3 PHASE TO 1 PHASE CONVERSION (KB021JJ TO HB013JB)	1
16*	14882	KIT, 3 PHASE TO 1 PHASE CONVERSION (HB014JB TO AA0611084)	1
16*	14678	KIT, 3 PHASE TO 1 PHASE CONVERSION (AA0611085 & ABOVE)	1

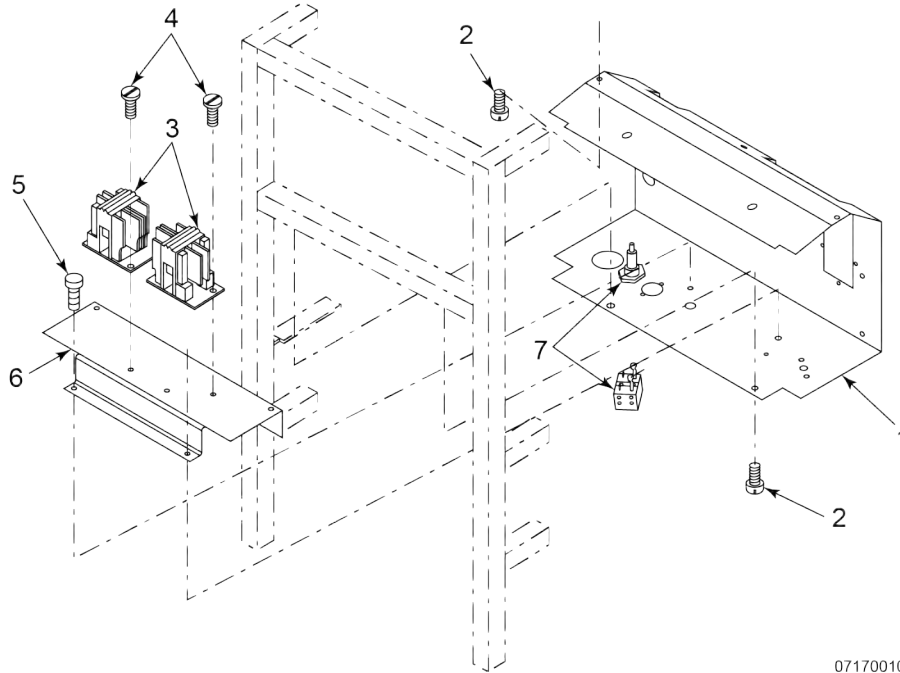

07170010

Figure 3-29 Contactor & Frame Assembly (Three Phase Electric Model)

Item No.	Part No.	Description	Qty.
Recommended Parts * Not Shown			
1	18514	SHROUD, THREE PHASE (KB020JJ & BELOW)	1
1	59233	SHROUD, THREE PHASE (KB021JJ TO HB013JB)	1
1	65863	SHROUD, THREE PHASE (HB014JB & ABOVE) (CE)	1
1	65269	SHROUD, THREE PHASE (AA0605139 & ABOVE)	1
2	SC03-005	SCREW, SHROUD	4
3	19405	CONTACTOR, 208-240 VOLT	2
3	65074	CONTACTOR, 230 VOLT (CE)	2
4	SC04-002	SCREW, CONTACTOR	4
5	SC01-052	SCREW, 1/4-20 X 3/8 HEX HD C	2
6	58850	BRACKET, DOUBLE CONTACTOR (KB021JJ & ABOVE)	1
7	EF02-125	BREAKER, PUSH-BUTTON RESET (10-23-06 & AFTER - DOMESTIC) (AA0809149 & AFTER - CE)	2

Item No.	Part No.	Description	Qty.
7	18364	ASSY., FUSE HOLDER - 15 AMP (BEFORE 10-23-06)	2
7	EF02-007	- FUSE, 15 AMP	2
7	EF02-006	- HOLDER, FUSE	2
7	EF02-105	FUSE, 15 AMP (AA0605139 TO AA0809148) (CE)	2
7	EF02-104	HOLDER, FUSE (AA0605139 TO AA0809148) (CE)	2
8*	14034	KIT, 1 PHASE TO 3 PHASE CONVERSION (KB020JJ & BELOW)	1
8*	14679	KIT, 1 PHASE TO 3 PHASE CONVERSION (KB021JJ TO HB013JB)	1
8*	14883	KIT, 1 PHASE TO 3 PHASE W/ FUSES (HB014JB TO AA0611084)	1
8*	14680	KIT, 1 PHASE TO 3 PHASE CONVERSION (AA0611085 & ABOVE)	1

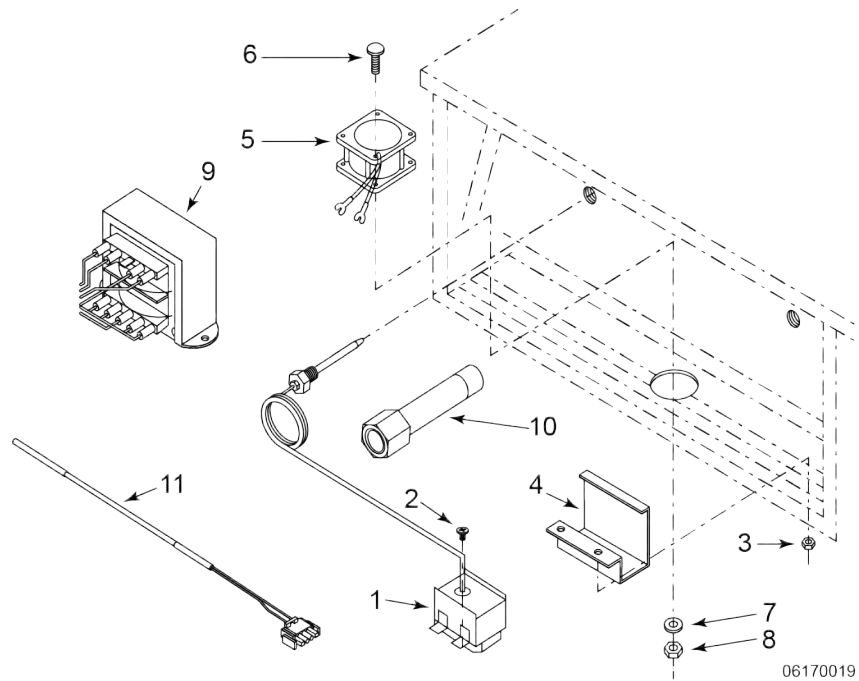

Figure 3-30 Fan & High Temperature Limit Control

Item No.	Part No.	Description	Qty.
Recommended Parts * Not Shown			
1	16738	CONTROL, HIGH TEMPERATURE LIMIT	1
1	60241	CONTROL, HIGH TEMP. LIMIT - E.G.O. (CA012JJ & ABOVE) (CE & AUSTRALIA)	1
1	14267	KIT, HIGH LIMIT (CA011JJ & BELOW) (CE)	1
2	SC02-018	SCREW, THREAD FORMING #8	2
3	NS02-001	NUT, #10-32 HEX KEPS	2
4	17216	BRACKET ASSY., HIGH LIMIT THERMOSTAT	1
5	81208	FAN, 120 VOLT	1
5	16688	FAN, 240 VOLT (AN0810093 & BELOW)	1
5	81117	FAN, 240 VOLT (AN0810094 & ABOVE)	1
6	SC01-266	SCREW, FAN - 6-23 X 1-3/4"	4
7	WA01-006	WASHER, FAN	4

Item No.	Part No.	Description	Qty.
8	NS02-005	NUT, FAN	4
9	35916	TRANSFORMER, 120V - PRI./24V - SEC	1
9	30614	TRANSFORMER, 208/240V - PRI./24V - SEC	1
10	51071	FITTING, THERMOSTAT (KA020JJ & BELOW)	2
11	68078	ASSY., FPS TEMPERATURE PROBE (WHEN APPLICABLE)	1
12*	36097	GUARD, PROBE	1

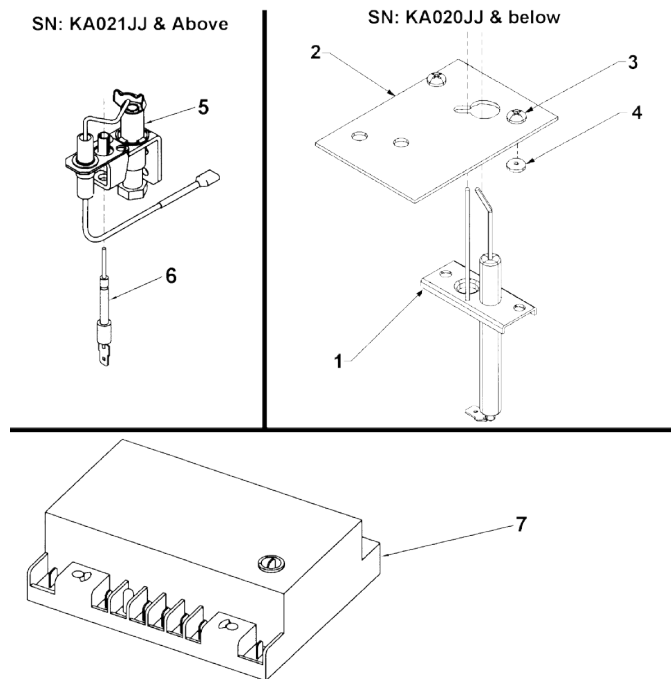
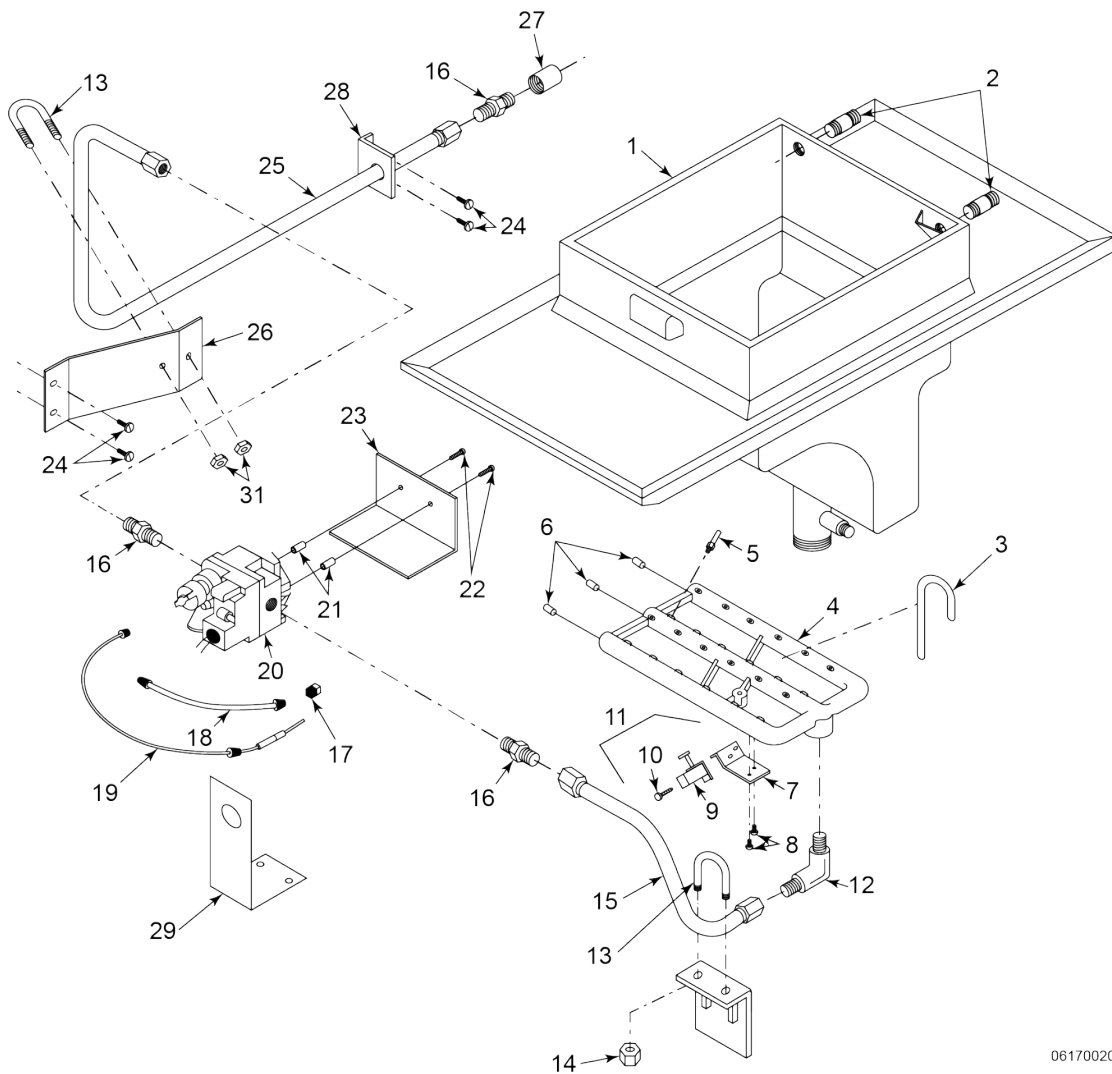

Figure 3-31 Electronic Ignition Assembly

Item No.	Part No.	Description	Qty.
Recommended Parts * Not Shown			
1	34380	ELECTRODE, SPARK/SENSE (KA020JJ & BELOW)	1
2	34376	BRACKET, IGNITOR (KA020JJ & BELOW)	1
2	21522	BRACKET, IGNITOR (KA021JJ & ABOVE)	1
2	21325	BRACKET, IGNITOR (INT'L) (KA020JJ & BELOW)	1
3	SC01-021	SCREW	2
3	SC01-076	SCREW (INT'L) (KA020JJ & BELOW)	2
4	NS02-007	NUT, KEPS	2
5	79132-1	PILOT, PFG - 600 NATURAL (AN1208071 & ABOVE)	1
5	140227	KIT, 600 NAT SSI PILOT ASSY. (KA021JJ TO AN1208070)	1
5	79132-2	PILOT, PFG - 600 LP (AN1208071 & ABOVE)	1

Item No.	Part No.	Description	Qty.
5	14931	KIT, 600 SSI PILOT ASSY. - LP (KA021JJ TO AN1208070)	1
6	14899	KIT, 600 SENSOR FLM HARN FLM	1
6	60292	SENSOR, FLAME - PILOT (KA021JJ & ABOVE)	1
7	140133	KIT, IGNITION MODULE (KA020JJ & BELOW)	1
7	21318	MODULE, IGNITION (INT'L) (KA020JJ & BELOW)	1
7	14919	KIT, IGNITION MODULE (KA021JJ TO AN0711029) (NON-CE)	1
7	77839	- MODULE, IGNITION (AN0711030 & ABOVE) (NON-CE)	1
7	14937	KIT, IGNITION MODULE (KA021JJ TO AN0711029) (CE)	1
7	77602	- MODULE, IGNITION (KA020JJ & BELOW) (CE)	1
8*	21317	SWITCH, MOMENTARY RESET (KA020JJ & BELOW)	1
9*	54472	RELAY, POWER - 15A 120V	1
9*	56394	RELAY, POWER - 10A 240V (CE)	1
10*	80854	BRACKET, IGNITION MODULE	1



06170020

Figure 3-32 Vat (frypot) & Gas Burner Assy - Non-CE, Domestic, & Electric Ignition

Item No.	Part No.	Description	Qty.
Recommended Parts * Not Shown			
1	16889	TOP ASSY., POT & COUNTER (KA020JJ & BELOW)	1
1	65007	TOP ASSY., POT & COUNTER (KA021JJ & ABOVE)	1
1	68568	TOP ASSY., POT & COUNTER - FPS	1
1	69722	TOP ASSY., POT & COUNTER - FPS	1

Item No.	Part No.	Description	Qty.
1	65010	TOP ASSY., POT & COUNTER - POLLO CAMPERO (KA021JJ & ABOVE)	1
1	65011	TOP ASSY., POT & COUNTER - CE (KA021JJ & ABOVE; USE 16889 PRIOR)	1
2	18816	NIPPLE, PIPE SS	2
3	53834	J-BOLT, BURNER HOLD DOWN	1
4	16205	CASTING BURNER	1
5	17013-1	SET, ORIFICE - NATURAL GAS	1
5	16561-1	- ORIFICE, NATURAL GAS - SS	1
5	16562-1	- ORIFICE, NATURAL GAS - BRASS	23
5	17013-3	SET, ORIFICE - PROPANE GAS	1
5	16561-3	- ORIFICE, PROPANE GAS - SS	1
5	16562-3	- ORIFICE, PROPANE GAS - BRASS	23
6	FP01-020	PLUG, BURNER CASTING	3
7	29969	BRACKET, PILOT HOLDER	1
8	SC01-184	SCREW, PILOT HOLDER BRACKET	2
9	USE #11	ASSY., PILOT & ORIFICE	1
10	SC01-047	SCREW, PILOT HOLDER	1
11	30904	ASSY., PILOT & BRACKET - LP (AN0703021 & BELOW)	1
11	30913	ASSY., PILOT & BRACKET - NAT (AN0703021 & BELOW)	1
12	16336	ELBOW, MALE	1
12	FP01-014	ELBOW, 1/8" (AN0901029 & ABOVE)	1
13	SC06-013	BOLT, U - GAS LINE	2
14	NS02-002	NUT, GAS SUPPLY LINE BOLT	4
15	16333	LINE, GAS BURNER TO CONTROL	1
15	67202	ASSY., BURNER TO VALVE TUBE - SOLID STATE IGN.	1
15	79239	ASSY., BURNER TO VALVE TUBE (AN0901029 & ABOVE)	1
16	16335	NIPPLE, CLOSE	3

Item No.	Part No.	Description	Qty.
17	29820	ORIFICE, PILOT - NATURAL GAS	1
17	32407	ORIFICE, PILOT - PROPANE GAS	1
18	69450	PILOT ASSEMBLY, GAS TUBE	1
19	16219	THERMOCOUPLE	1
20	-----	VALVE, GAS CONTROL - SEE <a href="#">Figure 2-11 Gas Control Valve, page 33</a>	1
21	16221	SPACER, HEAT SHIELD	2
21	ME50-066	SPACER, HEAT SHIELD (AN0901029 & ABOVE)	2
22	SC01-054	SCREW, HEAT SHIELD	2
22	SC02-045	SCREW, HEAT SHIELD (AN0901029 & ABOVE)	2
23	58866	SHIELD, HEAT - ALUMINUM (KA021JJ & BELOW)	1
23	67111	SHIELD, VALVE HEAT - SSI (KA021JJ TO AN0901028)	1
23	79197	SHIELD, VALVE HEAT (AN0901029 & ABOVE)	1
24	SC02-006	SCREW, BRACKET	4
25	40304	LINE, GAS SUPPLY (KA020JJ & BELOW)	1
25	16326	LINE, GAS SUPPLY	1
26	16331	BRACKET, GAS LINE	1
27	FP01-007	COUPLING, PIPE	1
28*	16328	BRACKET, GAS LINE	1
29	24687	GUARD, GAS VALVE ADJUSTMENT SCREW	1
30*	14484	KIT, 3/4 IN. X 5 FT. GAS LINE W/ QUICK-DISCONNECT	1
31	NS02-002	NUT, GAS SUPPLY LINE BOLT	2
32*	16329	NUT, 37 FLARE FOR 5/8 OD	2
33*	16330	SLEEVE, 37 FLARE FOR 5/8	2
34*	140645	KIT, VAT (FRYPOT) INSULATION	1

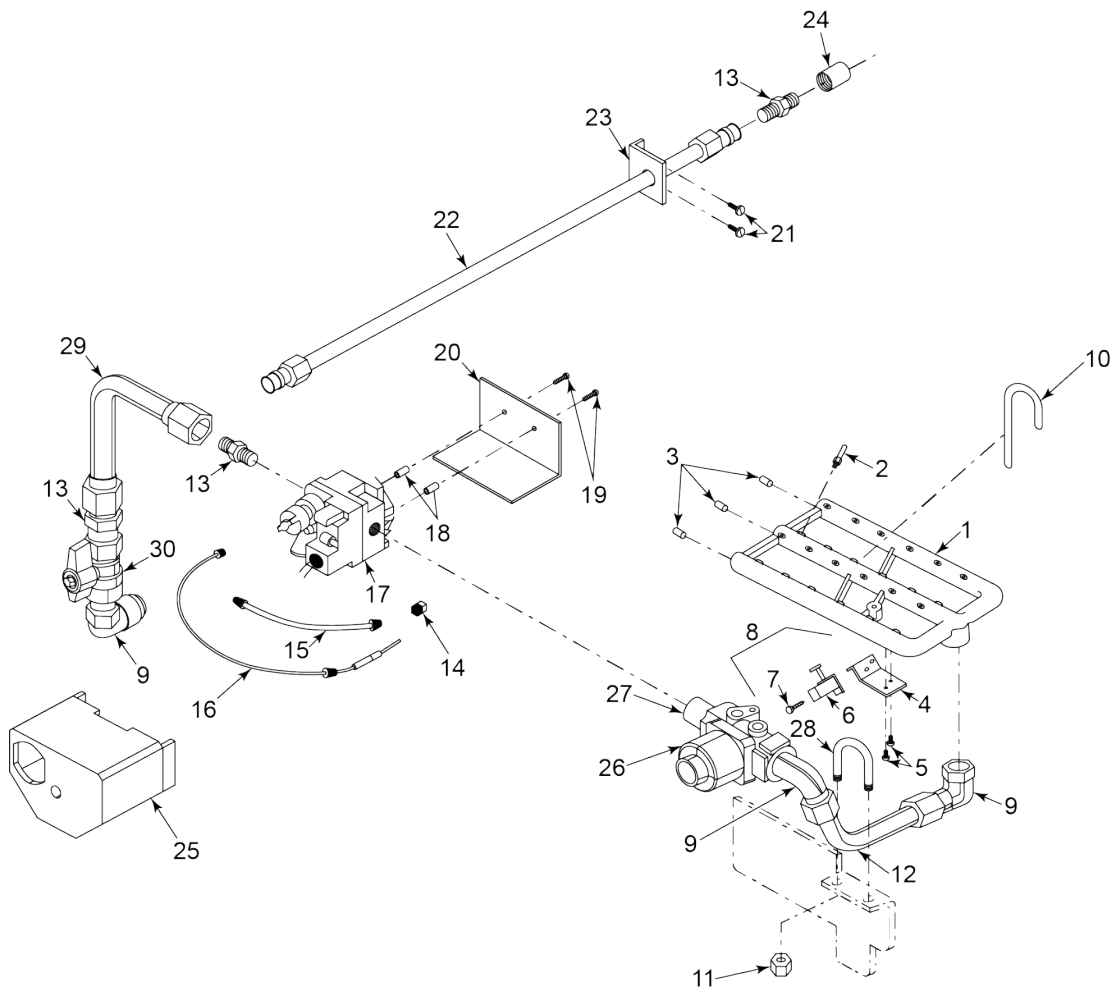

06170039

**Figure 3-33 Gas Line & Burner Assembly - CE, International, & Electronic Ignition**

Item No.	Part No.	Description	Qty.
Recommended Parts * Not Shown			
1	16205	CASTING, BURNER	1
2	17013-1	SET, ORIFICE - NATURAL GAS	1
2	16561-1	- ORIFICE, NATURAL GAS - SS	1
2	16562-1	- ORIFICE, NATURAL GAS - BRASS	23
2	17013-3	SET, ORIFICE - PROPANE GAS	1

Item No.	Part No.	Description	Qty.
2	16561-3	- ORIFICE, PROPANE GAS - SS	1
2	16562-3	- ORIFICE, PROPANE GAS - BRASS	23
3	FP01-020	PLUG, BURNER CASTING	3
4	29969	BRACKET, PILOT HOLDER	1
5	SC01-184	SCREW, PILOT HOLDER BRACKET	2
6	USE #8	ASSY., PILOT & ORIFICE	1
7	SC01-047	SCREW, PILOT HOLDER	1
8	30904	PILOT & BRACKET ASSY., LP (AN0703021 & BELOW)	1
8	30913	PILOT & BRACKET ASSY., NAT (AN0703021 & BELOW)	1
9	16336	ELBOW, MALE	1
10	53834	J-BOLT, BURNER HOLD DOWN	1
11	NS02-002	NUT, GAS SUPPLY LINE BOLT	4
12	38464	LINE, GAS BURNER TO CONTROL	1
13	16335	NIPPLE, CLOSE	2
14	29820	ORIFICE, PILOT - NATURAL GAS	1
14	32407	ORIFICE, PILOT - PROPANE GAS	1
15	69450	PILOT ASSEMBLY, GAS TUBE	1
16	16219	THERMOCOUPLE	1
16	34820	THERMOCOUPLE (CE)	1
17	-----	VALVE, GAS CONTROL - SEE <a href="#">Figure 2-11 Gas Control Valve, page 33</a>	1
18	16221	SPACER, HEAT SHIELD	2
19	SC01-054	SCREW, HEAT SHIELD	2
20	16222	SHIELD, HEAT - ALUMINUM	1
21	SC02-006	SCREW, BRACKET	4
22	51429	LINE, GAS SUPPLY (CE & AUSTRALIA)	1
22	-----	LINE, GAS FLEX W/ CONNECTOR - SEE	1
23	16328	BRACKET, GAS LINE	1
24	FP01-007	COUPLING, PIPE	1

Item No.	Part No.	Description	Qty.
25	56229	WIRE COVER, GAS CONTROL VALVE (CE)	1
26	38446	VALVE, GAS SOLENOID - 120V	1
26	38467	VALVE, GAS SOLENOID - 240V	1
26	38468	VALVE, GAS SOLENOID - 24V	1
26	169843	VALVE, GAS SOLENOID - 240V (CE & AUSTRALIA)	1
26	34802	VALVE, GAS SOLENOID - 24V (CE & AUSTRALIA) (BEFORE SERIAL NUMBER AN1901007)	1
26	91469	- ASSY, SAFETY VALVE CONNECTOR W/ WIRING (CE & AUSTRALIA) (BEFORE SERIAL NUMBER AN1901007)	1
26	170588	VALVE, GAS SOLENOID - 24V (CE & AUSTRALIA) (AFTER SERIAL NUMBER AN1901007)	1
26	170708	- ASSY, SAFETY VALVE CONNECTOR W/ WIRING (CE & AUSTRALIA) (AFTER SERIAL NUMBER AN1901007)	1
27	FP02-062	NIPPLE, 1/2 NPT X 1.75L BI	1
28	SC06-013	BOLT U, GAS LINE	1
29	51428	TUBE, GAS VALVE SUPPLY	1
30	45401	VALVE, 1/2 GAS BALL	1
31*	FP01-014	ELBOW, 1/8 INCH - Z	1
32*	FP01-200	FITTING, GAS INLET BSPT	1
33*	16355	NIPPLE, PRESSURE TEST	1

Length	Dia.	Part No.	Description	Qty.
36"	1/2"	03749	KIT, LINE GAS FLEX W/ INSTALLATION (w/ QD)	A/R
48"	1/2"	03750	KIT, LINE GAS FLEX W/ INSTALLATION KIT (1 QD)	A/R
48"	1/2"	03751	KIT, LINE GAS FLEX W/ INSTALLATION KIT (2 Swivel)	A/R
36"	3/4'	03752	KIT, LINE GAS FLEX W/ INSTALLATION KIT (w/ QD)	A/R
38"	3/4'	03753	KIT, LINE GAS FLEX W/ INSTALLATION KIT (Valve)	A/R
60"	3/4'	03754	KIT, LINE GAS FLEX W/ INSTALLATION KIT (1 QD)	A/R
48"	3/4'	03747	KIT, LINE GAS FLEX W/ INSTALLATION KIT (2 Swivel)	A/R
72"	1"	03755	KIT, LINE GAS FLEX W/ INSTALLATION KIT (2 Threaded Connectors)	A/R
33"	1"	03756	KIT, LINE GAS FLEX W/ INSTALLATION KIT (1" QD Adapter, Valve, Elbow)	A/R
48"	1"	03757	KIT, LINE GAS FLEX W/ INSTALLATION KIT (2 Swivel)	A/R
72"	1"	03758	KIT, LINE GAS FLEX W/ INSTALLATION KIT (1" QD Adapter, Valve, Elbow)	A/R
60"	1"	03759	KIT, LINE GAS FLEX W/ INSTALLATION KIT (2 Swivel + 1 QD)	A/R
Recommended Parts * Not Shown				

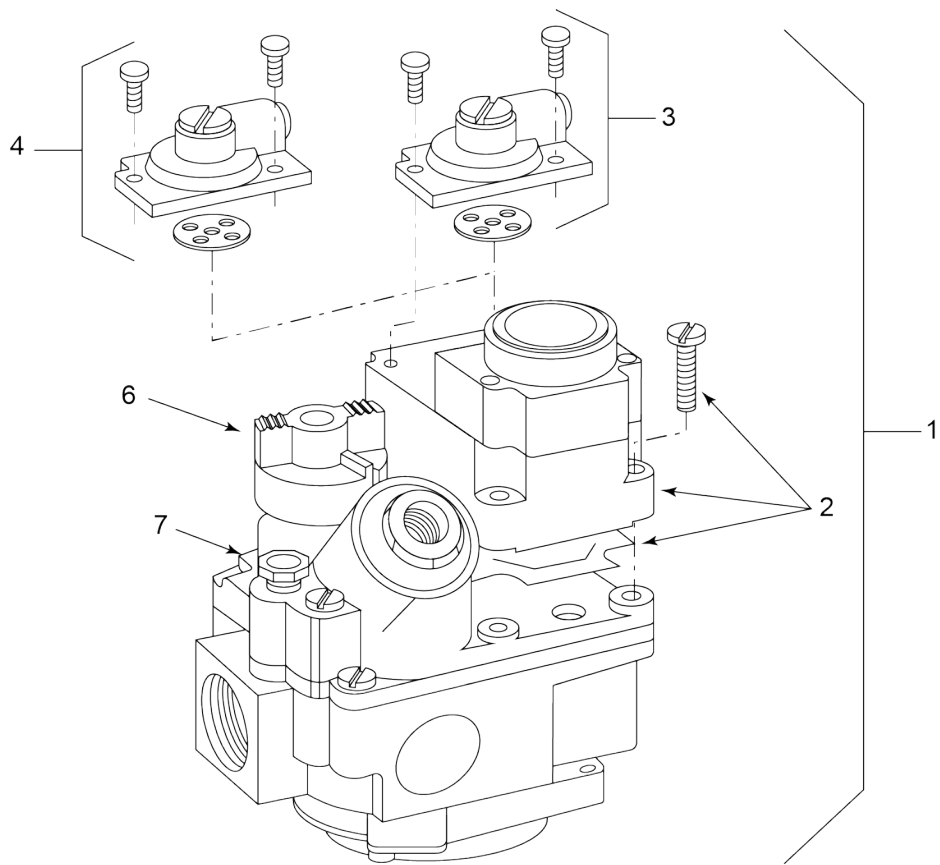

STYLE 1

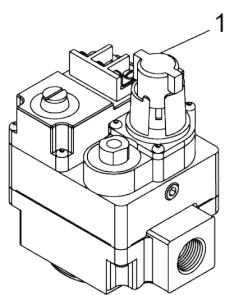

STYLE 2

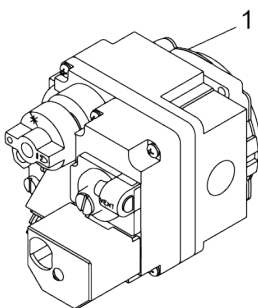

STYLE 3

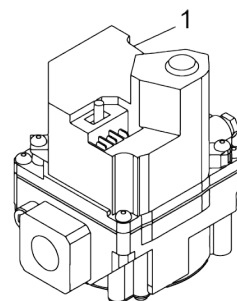

STYLE 4

06170021

Figure 3-34 Gas Control Valve

Item No.	Part No.	Description	Qty.
√ Recommended Parts * Not Shown			
1	-----	VALVE, GAS CONTROL - SEE <a href="#">Table 3-5 Table 1, page 167</a>	1
2	16254	ACTUATOR, GAS CONTROL VALVE - 120 VOLT - NATURAL	1
2	16710	ACTUATOR, GAS CONTROL VALVE - 208-240 VOLT - NATURAL	1
2	16386	ACTUATOR, GAS CONTROL VALVE - 120 VOLT - PROPANE	1
2	16384	ACTUATOR, GAS CONTROL VALVE - 208-240 VOLT - PROPANE	1
3	16253	REGULATOR, GAS CONTROL VALVE - NATURAL GAS	1
4	16352	REGULATOR, GAS CONTROL VALVE - PROPANE GAS	1
6	16267	KNOB, GAS CONTROL VALVE	1
7	16373	FITTING, COMPRESSION - PILOT TUBE	2
8*	16247	KIT, NAT. TO LP CONVERSION - SEE <a href="#">Table 3-6 Table 2, page 167</a>	1
8*	16248	KIT, LP TO NAT. CONVERSION - SEE <a href="#">Table 3-6 Table 2, page 167</a>	1
8*	14324	KIT, NAT. TO LP CONVERSION - SEE <a href="#">Table 3-6 Table 2, page 167</a>	1
8*	14325	KIT, LP TO NAT. CONVERSION - SEE <a href="#">Table 3-6 Table 2, page 167</a>	1
8*	14723	KIT, 600SSI - NAT. TO LP CONVERSION (KA021JJ & ABOVE)	1
8*	14724	KIT, 600SSI - LP TO NAT. CONVERSION (KA021JJ & ABOVE)	1

Table 3-5 Table 1

Voltage	Nat. Electronic Ign.	LP Electronic Ign.	Nat. STD Ign.	LP STD Ign.	Town Gas
120V	†34439 (KA020JJ & Below)	-	†16216	†16217	Use 16262 and 16254
240V	-	†21316	†16380	†16381	†16262
24V	◇140043 (KA021JJ to AN0901028)	◇140043 (KA021JJ to AN0901028)	#29614 (KA020JJ & Below)	#29728 (KA020JJ & Below)	-
24V	◇80761 (AN0901029 & Above)	◇80858 (AN0901029 & Above)	‡58863 (KA021JJ & Above)	‡64036 (KA021JJ & Above)	-
24V/50Hz	-	-	#34806	#34805	-
240V/50Hz	-	-	#34804	#34803	-
† - Style 1, Integral lead wires			‡ - Style 2, 3 screw terminals		
# - Style 3, 2 screw terminals and/or cover			◇ - Style 4, 3 spade terminals and ON/OFF switch		

**NOTICE**

Part # 16216 and 16380 consist of items 2 and 3; part # 16217 and 16381 consist of items 2 and 4.

Table 3-6 Table 2

Serial No.	STD USA 120V/60 Hz Power	STD European & Non-STD Power
KA020JJ & BELOW	16247 & 16248	16247 & 16248
KA021JJ & ABOVE	14324 & 14325	16247 & 16248

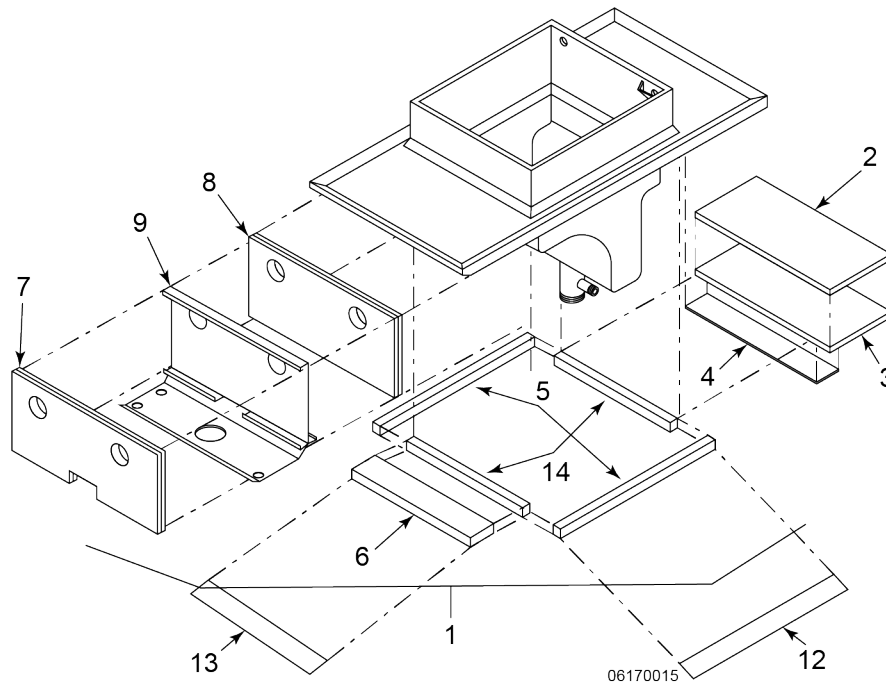
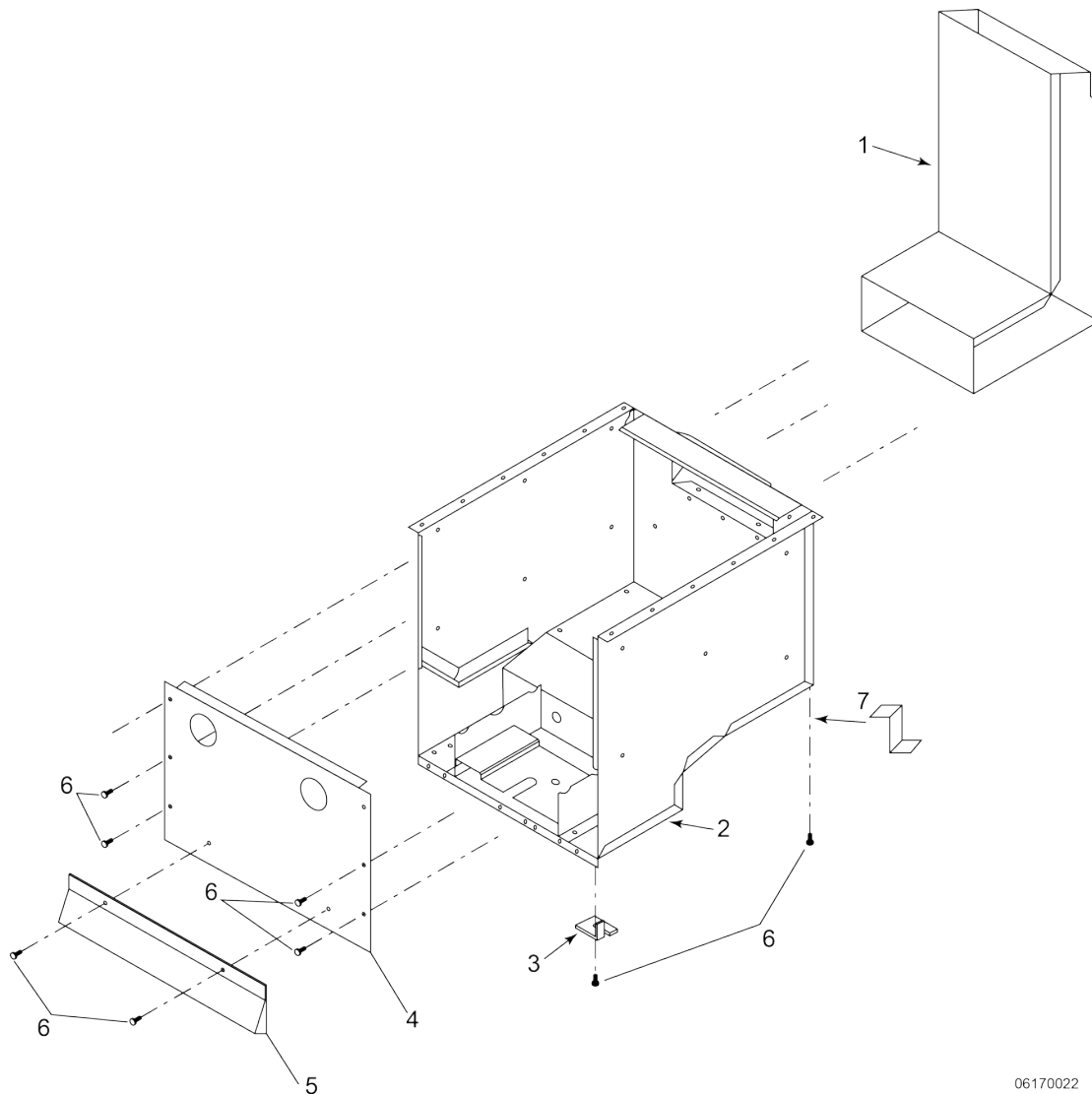

Figure 3-35 Countertop Insulation Assembly (Gas Model)

Item No.	Part No.	Description	Qty.
* Not Shown			
1	14698	KIT, COMPLETE SET (KA021JJ & ABOVE)	1
1	16518	INSULATION, COMPLETE SET (35886 TO KA020JJ)	1
1	16310	INSULATION, COMPLETE SET (35886 & BELOW) (INCLUDES PART NO. 16505, 17605, 16872, MS01-180, BULK CEREFELT INSULATION FOR AROUND THERMOCOUPLE, POT FITTINGS, & GLUE)	1
1	14211	INSULATION, COMPLETE SET (CE & AUSTRALIA)	1
2	63301	INSULATION, FIBERGLASS	1
2	63326	INSULATION (CE & AUSTRALIA)	2
3	63302	INSULATION, CEREFELT - FLUE TOP	1
3	63326	INSULATION, CEREFELT - FLUE TOP (CE)	1
4	16308	BOARD, AIRCELL	1
4	54862	BOARD, AIRCELL (CE & AUSTRALIA)	1

Item No.	Part No.	Description	Qty.
5	53807	INSULATION, COUNTERTOP - SIDES	2
6	16303	INSULATION, FIBERGLASS	1
7	63699	INSULATION, FIBERGLASS NOTCHED	2
7	68070	ASSY., FRONT PANEL INSULATION - SSI/FPS	1
8	63623	INSULATION, HEAT SHIELD - INNER	1
9	59232	SHIELD, HEAT	1
10*	53802	SHIELD, HEAT - MIDDLE - (AN0810093 & BELOW) (CE & AUSTRALIA)	1
11*	80861	SHIELD, HEAT - (AN0810094 & ABOVE) (CE & AUSTRALIA)	1
11*	85512	SHIELD, HEAT - 240V SSI/FPS (AN0810093 & BELOW)	1
11*	85518	SHIELD, HEAT - 240V SSI/FPS (AN0810094 & ABOVE)	1
12	59965	INSULATION, COUNTERTOP SIDE	2
13	59966	INSULATION, COUNTERTOP FRONT	1
14	53808	INSULATION, COUNTERTOP - FRONT/REAR	2



06170022

Figure 3-36 Firebox & Flue Assembly (Gas Model)

Item No.	Part No.	Description	Qty.
* Not Shown			
1	59728	STACK, FLUE EXHAUST (KA021JJ & ABOVE)	1
1	54865	STACK, FLUE EXHAUST (KA020JJ & BELOW)	1
2	59223	ASSY., CABINET - FIREBOX (KA021JJ & ABOVE)	1
2	29679	ASSY., CABINET - FIREBOX (KA020JJ & BELOW)	1

Item No.	Part No.	Description	Qty.
3	18625	BRACKET, SIDE PANEL INSULATION	2
4	87448	PANEL, FIREBOX FRONT	1
5	16406	DEFLECTOR, HEAT SHIELD	1
6	SC03-005	SCREW, SHEET METAL	20
7	18626	BRACKET, SIDE PANEL INSULATION - REAR	2
8*	63330	ASSY., FIREBOX - W/ INSULATION - JAPAN (AN0902073 & BELOW)	1
8*	63311	ASSY., FIREBOX - W/ INSULATION - JAPAN (AN0902074 & ABOVE)	1
8*	63331	ASSY., FIREBOX - W/ INSULATION (CE & AUSTRALIA)	1
9*	30857	ASSY., FRONT PANEL INSULATION (EXPORT ONLY)	1
10*	53812	INSULATION, FRONT BRACKET - FIREBOX (CE & AUSTRALIA)	2
11*	53814	INSULATION, LEG (CE & AUSTRALIA)	1
12*	53816	INSULATION, OUTER REAR FIREBOX (CE & AUSTRALIA)	1
13*	24239	INSULATION, OUTER FIREBOX - SIDE (CE & AUSTRALIA)	1

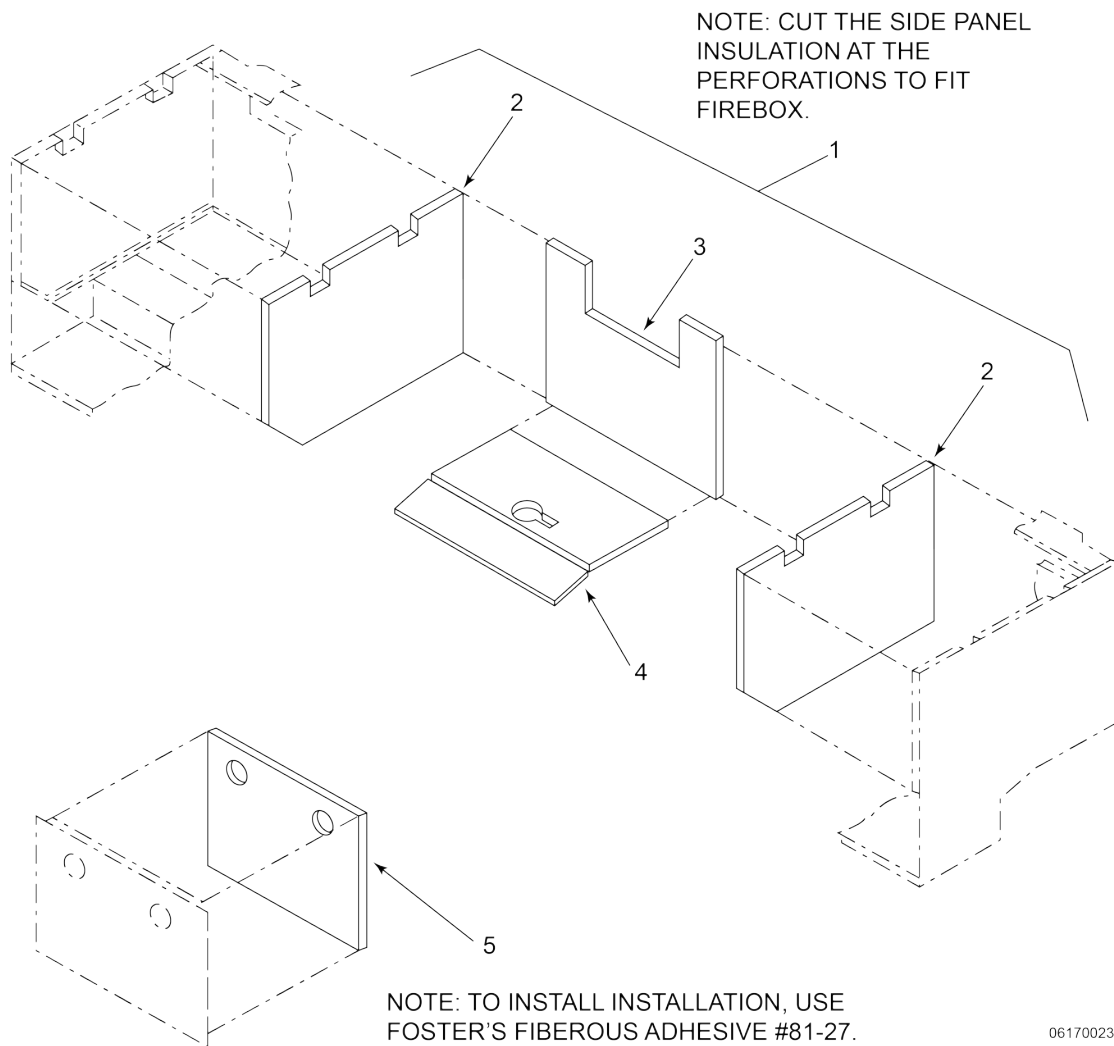

Figure 3-37 Firebox Insulation Assembly (Gas Model)

Item No.	Part No.	Description	Qty.
* Not Shown			
1	16505	INSULATION, FIREBOX - COMPLETE SET - CEREFELT - INSIDE FIREBOX	1
2	63111	- INSULATION, SIDE PANEL - CEREFELT	2
3	16502	- INSULATION, BACK PANEL - CEREFELT	1
4	16503	- INSULATION, BOTTOM PANEL - CEREFELT	1

<b>Item No.</b>	<b>Part No.</b>	<b>Description</b>	<b>Qty.</b>
5	29690	- INSULATION, FRONT PANEL - CEREFELT	1
6*	24238	- INSULATION, COUNTERTOP - SIDE - JAPAN (AN0902074 & ABOVE)	2



# Chapter 4 C8000 Replacement Parts

## 4.1 Controls and Decals

Part Number	Description	Quantity
164944	Flat panel assembly: SN: KA021JJ to GA085JB - Gas	1
164946	Flat panel assembly: SN: GA086JB and above - Gas	1
164945	Bent panel assembly: SN: KA020JJ and below - Gas	1
68798	Bent panel assembly - Campero: SN: KA020JJ and below - Gas	1
68799	Flat panel assembly - Campero: SN: KA021JJ to GA085JB - Gas	1
164960	Flat panel assembly - Campero: SN: GA086JB and above - Gas	1
65462	Bent panel assembly - Jollibee's: SN: KA020JJ and below - Gas	1
65463	Flat panel assembly - Jollibee's: SN: KA021JJ to GA085JB - Gas	1
164954	Flat panel assembly - Jollibee's: SN: GA086JB and above - Gas	1
65171	Control assembly - Express Foods:	1
65193	Control assembly - Servequip:	1
164967	Control assembly - 600 Wendy's w/SSI/FPS: SN: GA086JB and above - Gas	1
68683	Control assembly - Wendy's w/SSI/FPS: SN: GA085JB and below - Gas	1
164970	Control assembly - '02 GM w/FPS:	1
69307	Control assembly - '02 Giant Eagle:	1
- 64120	AMP sensor PCB	1
65893	Dual gas module I/O W/PS assembly	1

Part Number	Description	Quantity
32633	Std. product menu card	1
32634	Blank menu card	1
69228	Campero menu card	1
39089	Jollibee menu card	1
39156	Wendy's/Davco menu card	1
68731	Giant Eagle menu card	1
70846	McDonalds menu card	1
27308	Bent control decal	1
24849	Flat control decal	1
32658	C8000-02 decal	1
39269	C8000-02 Wendy's decal	1
72170	C8000-02 Wendy's English / French decal	1
29898	Power switch	1

## 4.2 600 Series Gas Control Valve

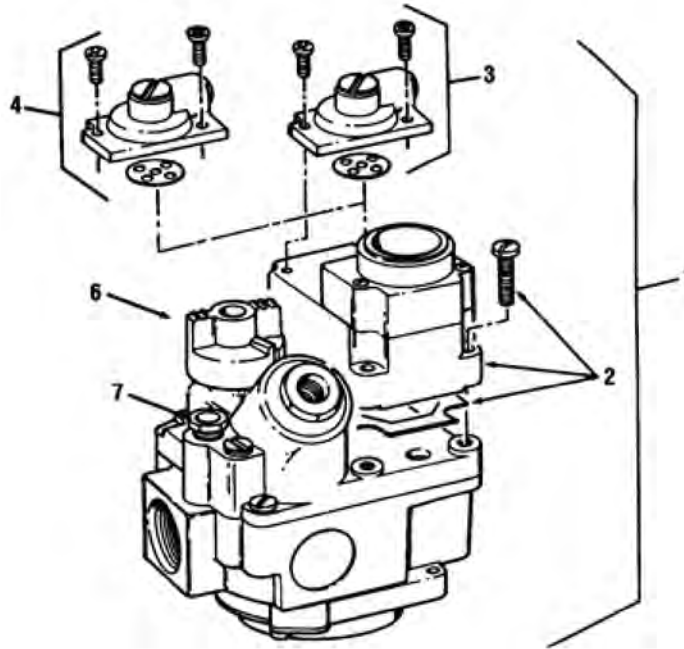

Item	Part Number	Description	Quantity
1a	58863	Natural Gas Valve 24v SN: (KA021JJ Above)	1
1a	16216	Natural Gas Valve 120v	1
1b	64036	Propane Gas Valve 24v SN: (KA021JJ Above)	1
1b	16217	Propane Gas Valve 120v	1
1a	16380	Natural Gas Valve 208-240v	1
1b	16381	Propane Gas Valve 208-240v	1
1a	29614	Natural Gas Valve 24v SN: (Below KA020JJ)	1
1b	29728	Propane Gas Valve 24v SN: (Below KA020JJ)	1
2	16254	Gas Control Valve Solenoid 120v NG	1
2	16710	Gas Control Valve Solenoid 208- 240v NG	1
2	16386	Gas Control Valve Solenoid 120 LP	1

Item	Part Number	Description	Quantity
2	16384	Gas Control Valve Solenoid 208- 240v LP	1
3	16253	Gas Control Valve Regulator 3.5 in.	1
4	16352	Gas Control Valve Regulator 10 in.	1
6	16267	Gas Control Valve Knob	1
7	16373	Pilot Tube End Compression Fitting	2

### 4.3 600 Series Gas Components

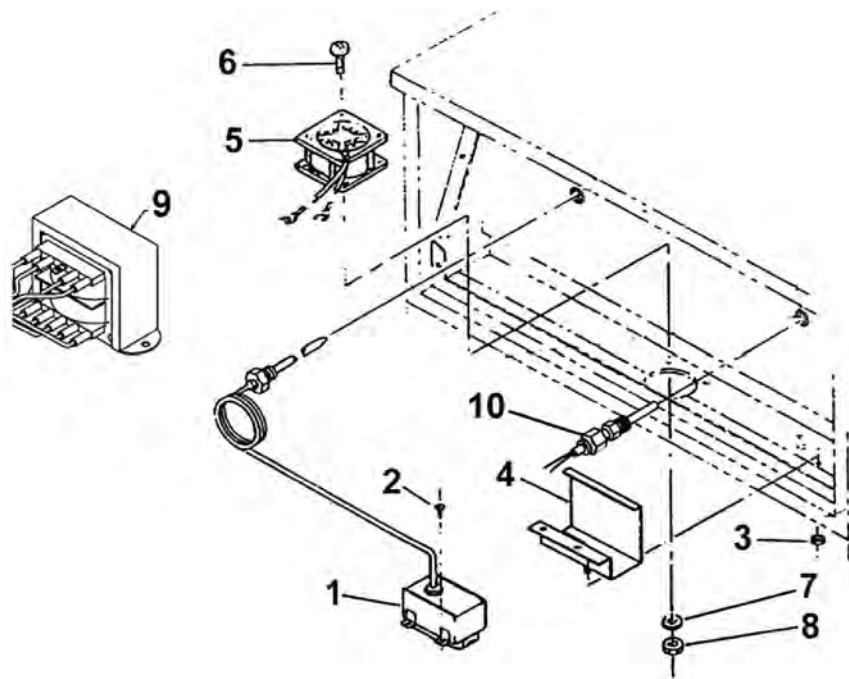

Item	Part Number	Description	Quantity
1	16738	High Temperature Limit Control	1
2	SC02-018	#8 Thread Forming Screw	2
3	NS02-001	#10-32 Hex Keps Nut	2
4	17216	High Limit Thermostat Bracket Assembly	1
5	16684	120 Volt Fan	1
6	SC01-010	- Fan Screw	4
7	WA01-006	- Fan Washer	4

Item	Part Number	Description	Quantity
8	NS02-005	- Fan Nut	4
9	72854	10/24v AC Transformer Assembly	1
10	14331	Temperature Probe Kit	1
10	14877	600 FPS Temperature Probe Kit	1
11*	36097	Probe Guard	1

## 4.4 Rear Panel Wiring Connection Decal

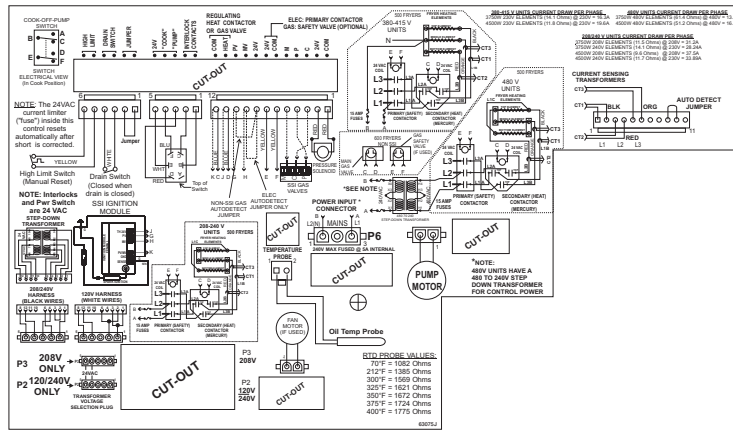

# 4.5 600 230v 50/60Hz. 1PH

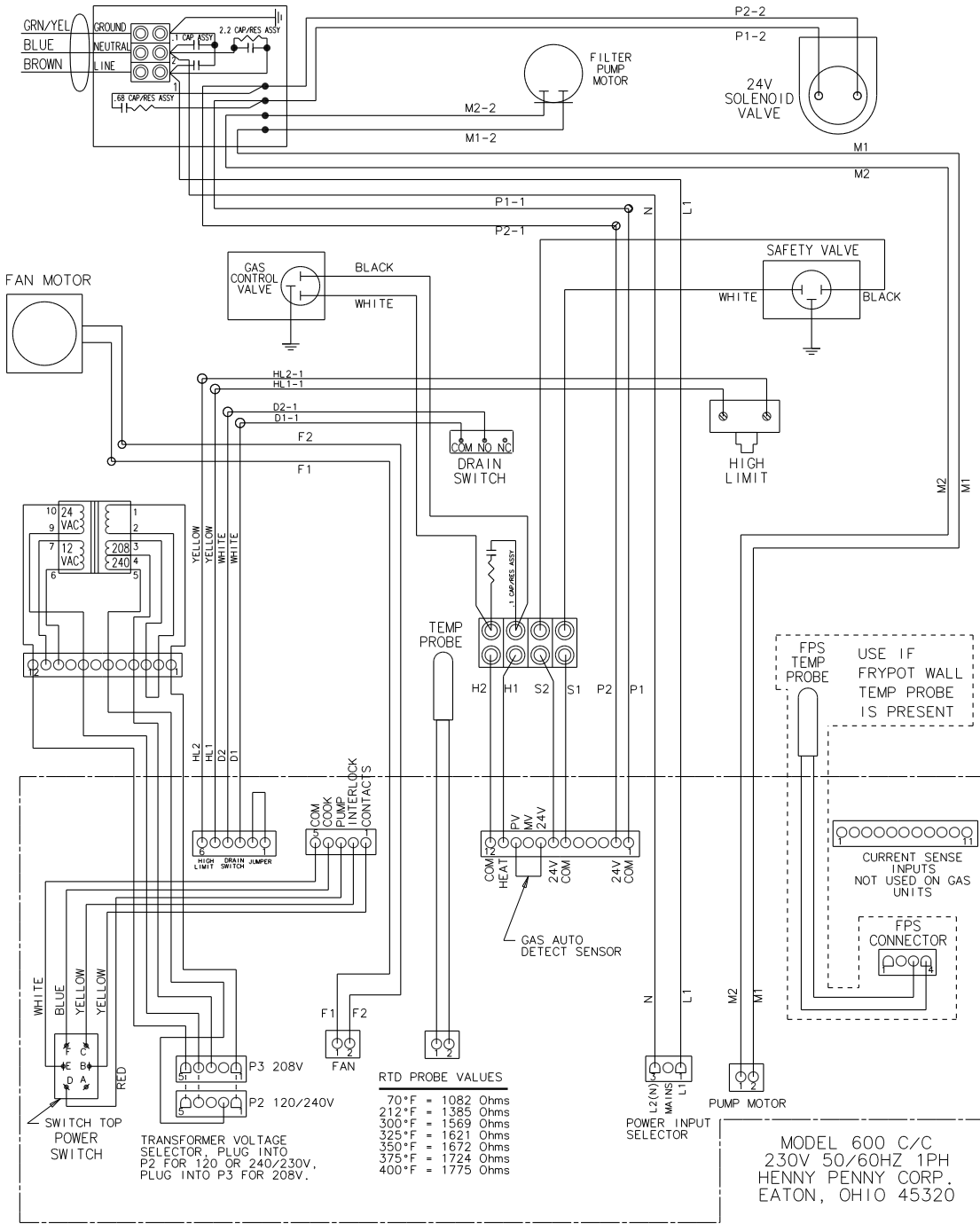

32758

# 4.6 600 208-240v 50/60Hz. 1PH

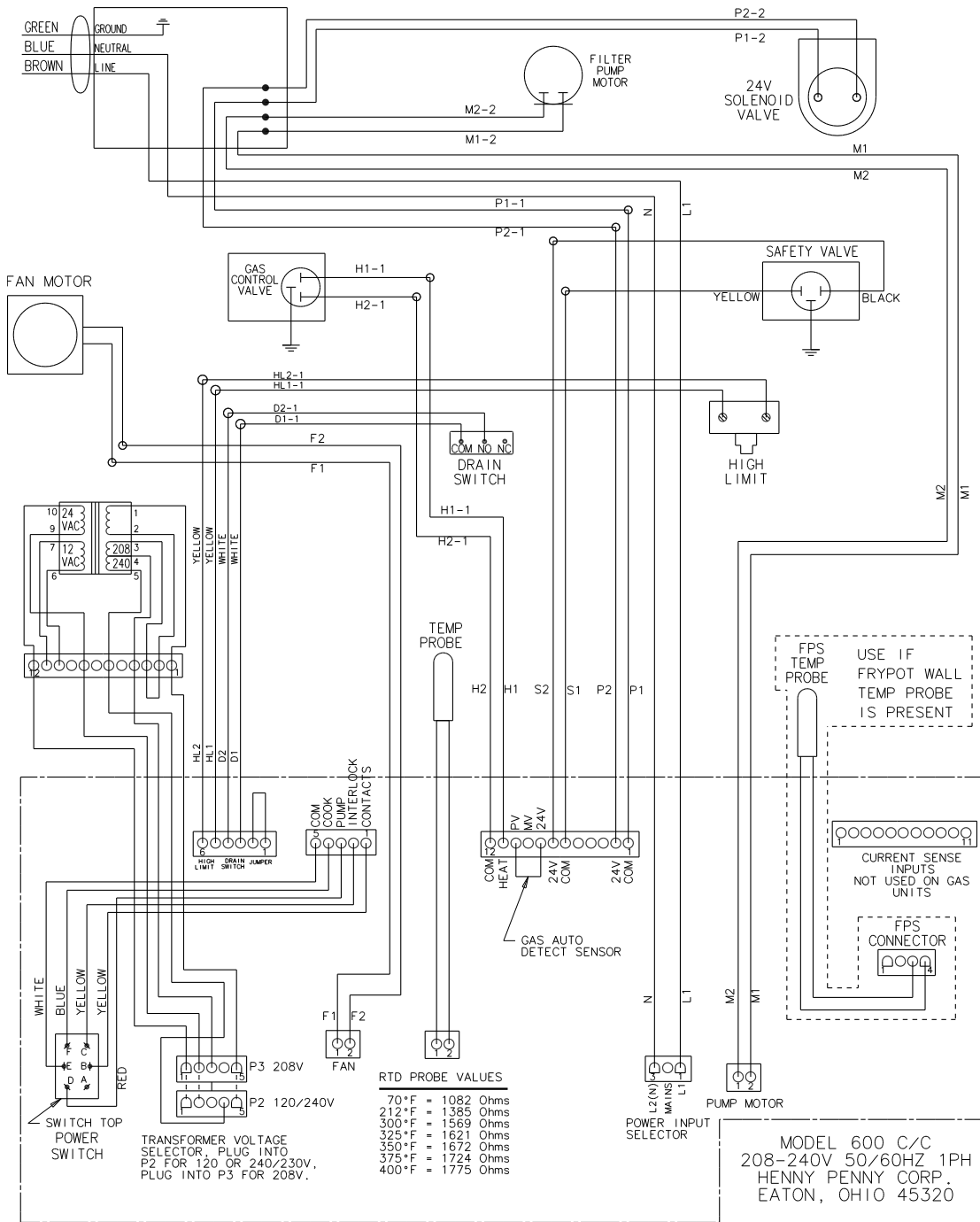

32759

# 4.7 600 120v 50/60Hz. 1PH

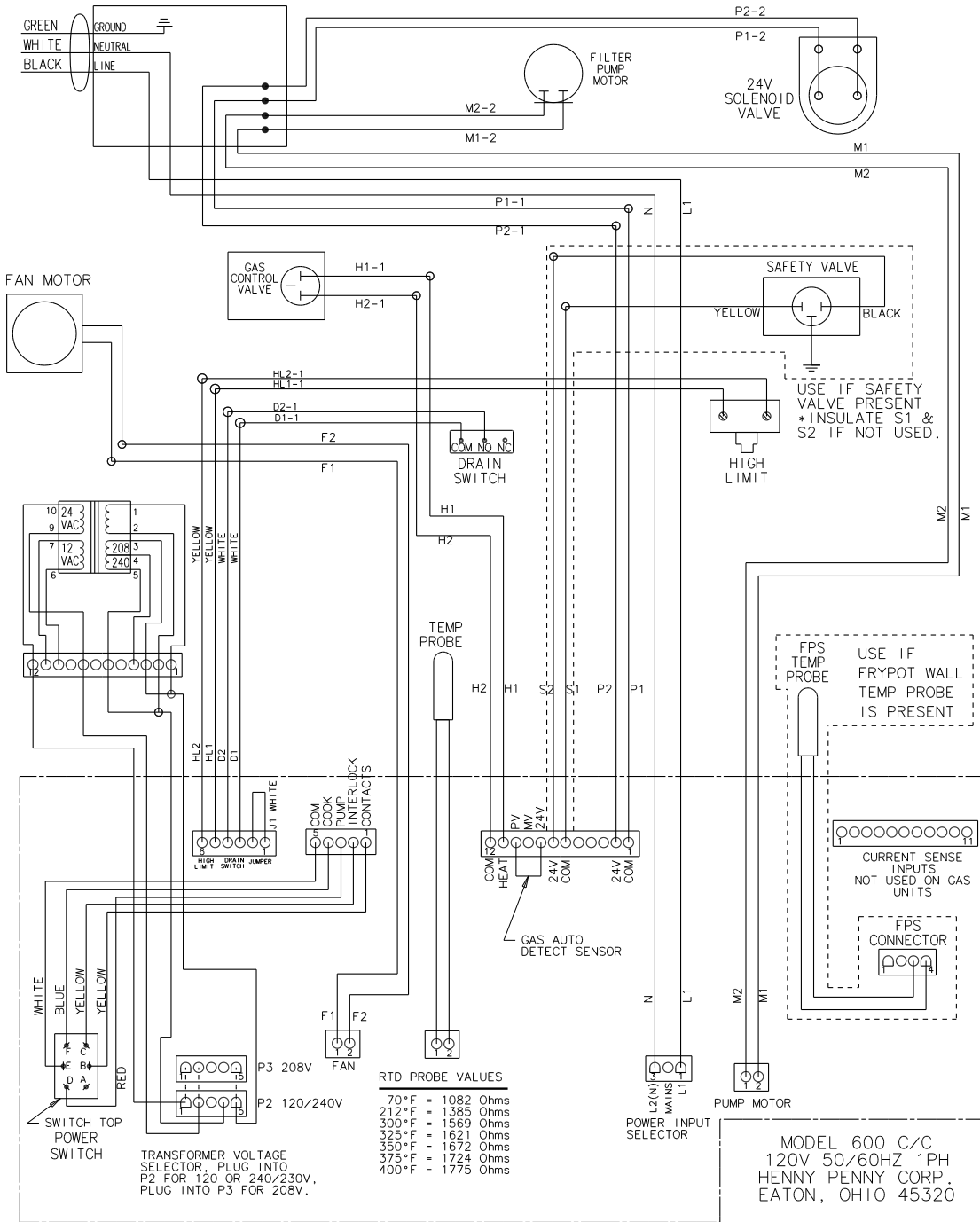

32760

### 4.8 600 120v 50/60Hz. 1PH

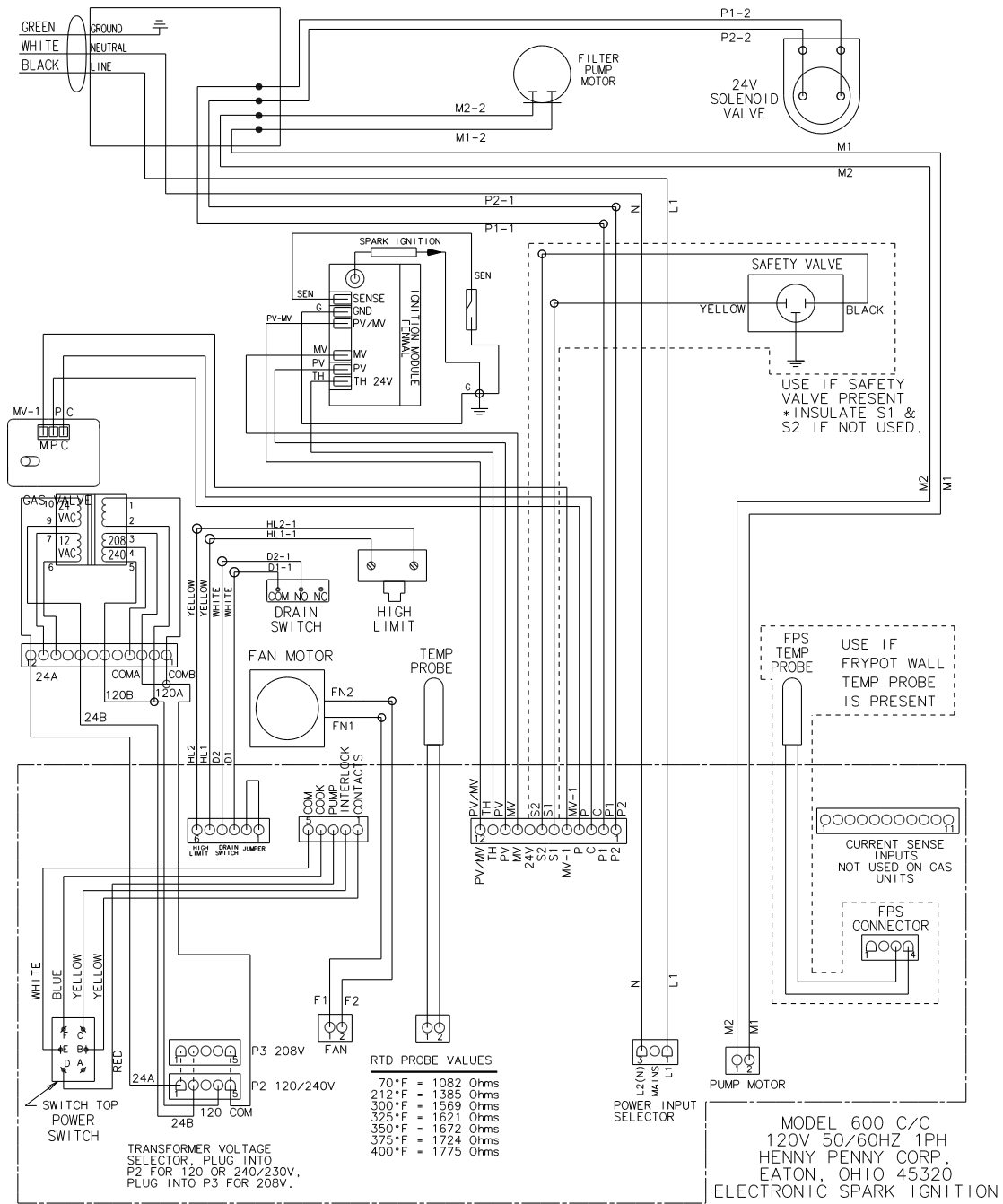

67199





# Chapter 5 Pressure Assist Features and Function

Pressure Assist is an optional, purchasable feature that allows operators to cook small loads and still maintain the required vat pressure necessary for pressure cooking. In the past, full loads were required in order for the fryer to build the required vat pressure. Pressure Assist adds additional pressure, as needed, to raise the vat pressure to the required 12 PSI cooking pressure. Low vat pressure will not allow the food to cook properly and consistently. But with Pressure Assist, small loads can be cooked with the same consistency as full loads. This feature provides the operator with more flexibility in meeting both customer and business needs by reducing waste and providing fresh cooked, high quality product in smaller amounts as needed.

## 5.1 Software

### 5.1.1 C8000 Controller

Access the Pressure Assist settings by doing the following:

1. Access Tech Mode T-2A, HAS PR ASSIST and set to YES. PRESSURE ASSIST: YES/NO displays when the fryer is initially powered on.  
NOTE: If NO is selected, the fryer's cook cycle operates as normal. The air pump stays off for the entire cook cycle.
2. Select YES, the setting 2. PR ASSIST DELAY SECONDS: 0 ... 120 seconds displays in Product Programming mode. A delay can be set between when the pressure solenoid valve turns on and the pressure assist pump also turns on:
  - Delay = 0: As soon as the pressure solenoid valve turns on, the pressure assist pump also turns on. The air pump cycles on and off as needed to maintain pressure for the rest of the cook cycle.
  - Delay = 1: During a cook cycle, when the pressure solenoid valve is first closed, the control initiates the programmed delay period. As soon as the delay expires, the pressure assist pump turns on. The air pump cycles on and off as needed to maintain pressure for the rest of the cook cycle.
3. Select desired delay. If 1 or more seconds of delay are chosen, the setting 3. PR ASSIST NOT NEEDED IF 'X' PSI: 0.0 ... 12.0 psi. 0.0 shown as "--" displays in Product Programming mode.
4. Select desired P.S.I. During a cook cycle, when the pressure solenoid valve is first closed, the control initiates the programmed delay period. As soon as the delay expires, the control assesses the naturally achieved pressurization level. If the pressure reading is at or above the "Not Needed" psi threshold, no pressure assist is performed at all for that cook cycle; otherwise, the pressure assist pump turns on and runs as needed to maintain pressure for the rest of the cook cycle.

EXAMPLE: (PrAssist = YES) and (Delay >= 1 second) and (NotNeededPSI >= 0.1 psi)

Air Pump Constraints:

1. The air pump is always off during the first (10) seconds of the cook cycle, because the user might still be trying to close the lid.
2. The air pump is always off if the pressure solenoid valve is off (open). The solenoid valve cycles on and off according to the programmed cook cycle.

# Chapter 6 Programming

Programming information is provided in this section. Operator menus are described in the Operator's manual and are not included in this manual. All menus that pertain to maintenance are described in this section. To enter the menus, perform the following steps:

- 1) Press and hold the PROGRAM button for five seconds.
- 2) Release the PROGRAM button as soon as "LEVEL 2" shows in the display.
- 3) Press the PROGRAM button until "TECH" is displayed (you are in tech mode now).
- 4) Enter the code 11221122.

The only menu used for maintenance for the Computron 8000 control is Tech Mode.

**Table 6-1 Programming**

Menu Step	Description
T-1 Software ID's	View software ID's Press and hold [1]: HP P/N = 32609J (HP part number for software.) Press and hold [2]: ID = HP C8000 (The specific customer or model number, etc.) Press and hold [3]: SRL = 1.50 (Software Release Level (version) for this software.)
T-2 Fryer Type	Auto-detected by the controller, based on I/O board and wiring harness connections. (This is not a setting you can adjust.) Auto-detection can complete only if the fryer is turned ON and the high-limit and drain switch interlocks are closed. If the display indicates "NEED VHDS", then one of the interlocks is not satisfied and the auto-detect routine is unable to proceed.
T-3 Push-Button Test	Push-button test mode. Press and release buttons (starting with any button other than INFO or PROG) to activate test mode. Main display shows an indicator letter for each button that is pressed: Number buttons 1-0, Info, Down, Up, Prog, Left-side (Idle), Right-side (Timer)
T-4 All-On Display Test	Press and hold any number button to cause all display digit segments, decimal points, LED's, and light bars to be lighted. Release button to return to normal mode.
T-5 Segments Test	Tests each individual display segment (all digits simultaneously) in order to assess whether any segments might be bridged together. Press and release any number button to step through the test sequence manually, or press and release the Timer button to run the test sequence automatically one time through.
T-6 Digits Test	Tests each individual display digit (all segments on, one digit at a time) in order to assess whether any solder bridges between digits exist.

Menu Step	Description
	Press and release any number button to step through the test sequence manually, or press and release the Timer button to run the test sequence automatically one time through.
T-7 Decimal PTS Test	This step tests each individual display digit decimal point. Press and release any number button to step through the test sequence manually, or press and release the Timer button to run the test sequence automatically one time through.
T-8 LED's Display Test	This step tests each individual discrete LED. The test pattern is as follows: Wait, Ready, Idle, Heat, Pressure, Info, Down, Up, Prog, Timer, 1, 2, 3, 4, 5, 6, 7, 8, 9, 0. Press and release any number button to step through the test sequence manually, or press and release the Timer button to run the test sequence automatically one time through.
T-9 Oil Temp - Calib/Offset/ Highest	View/set calibration offset for oil temperature probe. Also, view/reset max recorded oil temperature. Press and hold [1]: CALIB ADJ 327°F - UP/DOWN to adjust calibration viewed as a temp. Press and hold [2]: OFFSET ADJ+2°F - UP/DOWN to adjust calibration viewed as an offset. Press and hold [3]: HIGHEST 341°F - View highest recorded oil temperature. Reset max temp by pressing the DOWN button while viewing.
T-9A Aux Temp - Calib/Offset/ Highest	View/set calibration offset for auxiliary (dry-fire) temperature probe. Also, view/reset max recorded aux temperature. Press and hold [1]: CALIB ADJ 418°F - UP/DOWN to adjust calibration viewed as a temp. Press and hold [2]: OFFSET ADJ+0°F - UP/DOWN to adjust calibration viewed as an offset. Press and hold [3]: HIGHEST 463°F - View highest recorded aux temperature. Reset max temp by pressing the DOWN button while viewing.
T-10 CPU Temp - Calib/Offset/ Highest	View/set calibration offset for CPU board temp. Also, view/reset max recorded CPU board temp. Press and hold [1]: CALIB ADJ 87°F - UP/DOWN to adjust calibration viewed as a temp. Press and hold [2]: OFFSET ADJ +0°F - UP/DOWN to adjust calibration viewed as an offset. Press and hold [3]: HIGHEST 121°F - View highest recorded CPU temperature. Reset max by pressing the DOWN button while viewing.
T-11 View A-D Channels	This feature allows direct viewing of any channel of the analog-to-digital converter chip. This is mainly useful for troubleshooting. The channel can be selected using the UP or DOWN buttons. <0> CPU temperature (thermistor) <1> Safety Circuit Comparator Ref. <2> Safety Circuit Comparator Output <3> Aux. RTD input (unused) <4> Oil Tmp RTD input

Menu Step	Description
	<p>&lt;5&gt; Transformer secondary (P6-14)            &lt;6&gt; Amp Sensor auto-detect (P10-6)            &lt;7&gt; unused (P10-5)            &lt;8&gt; Amp sensor #3 (P10-4)            &lt;9&gt; Amp sensor #1 (P10-2)            &lt; A &gt; Amp sensor #2 (P10-3)            &lt; B &gt; 1/2 Scale (2.5v)            &lt; C &gt; Neg Vref (0.0v)            &lt; D &gt; Pos Vref (5.0v)</p> <p>The displayed value can be toggled between Volts and Bits by pressing the number 0 button.            If the displayed value has a decimal point and is followed by a “V” it is voltage (0 to 5 VDC).            If no decimal point is shown, the value is a-to-d bits (0 - 4095).</p>
<p>T-12 View The Status Of The 24v Interlock Circuit Digital Inputs:</p>	<p>Each interlock input has an associated indicator digit.            If the input signal is currently detected, an identifying letter is displayed.            If the signal is not detected, an underscore (“_”) is displayed.</p> <p><b>4-Hd Elec:</b>            F &amp; M are hard-wired on. P is hard-wired off.</p> <p><b>4-Head Electric Fryers:</b>            DIGITAL INPUTS - AB VHDSFPM            Normal Display: A_ VHDSF_M</p> <p><b>4-Hd Gas:</b>            F &amp; P are hard-wired on. M is hard-wired off.</p> <p><b>4-Head Gas Fryers:</b>            DIGITAL INPUTS - AB VHDSFPM            Normal Display: A_ VHDSFP_</p> <div style="text-align: center; border: 2px solid black; padding: 5px; width: fit-content; margin: 10px auto;"> <p><b>NOTICE</b></p> </div> <p>The “C” (pressure solenoid) input can only be read when the pressure output is turned OFF. When the pressure output is turned ON, the “C” input normally disappears.</p> <p><b>A</b> = Power switch “COOK” (ON) position input signal. There are two “power switch on” input signals, ‘A’ and ‘S’. The ‘A’ one is not dependent on the interlock chain, so the controller is always able to read the On/Off status of the power switch even if the high limit is tripped or the drain is open.</p> <p><b>B</b> = Power switch “PUMP” position input signal. Should not have A and B at the same time*.</p> <p>Note that this continuity signal can only be read when the pressure output is OFF. The “C” signal disappears whenever the pressure solenoid output is turned ON.</p> <p><b>V</b> = VOLTS – 24v detected at start of interlock chain. If “V” is missing, the 24v current limiter (fuse) might be tripped. This “fuse” device (located on the I/O board) automatically resets as soon as the short condition is fixed.</p>

Menu Step	Description
	<p><b>H</b> = HIGH LIMIT – If “H” is present, the high limit is good. If “H” is missing, the high limit is tripped out (overheated) or disconnected.</p> <p><b>D</b> = DRAIN SWITCH – If “D” is present, the drain handle is closed. If “D” is missing, the drain switch is open or disconnected.</p> <p><b>S</b> = Power switch “on” interlock circuit: If “S” is present, the power switch is in the ON position. If the “S” is missing, the power switch is either off, failed, or wired incorrectly.</p> <p><b>4-Head Electric and 4-Head Gas Fryers:</b></p> <p><b>F</b> = The “F” input is always hardwired ON. (These fryers do not have fan vacuum sensors.)</p> <p><b>P</b> = “Gas” auto-detect jumper.</p> <ul style="list-style-type: none"> <li>• 4-Hd Gas Fryers: This signal is hardwired ON.</li> <li>• 4-Hd fryers: This signal is hardwired OFF and should never be present.</li> </ul> <p><b>M</b> = “Electric” auto-detect jumper.</p> <ul style="list-style-type: none"> <li>• 4-Hd fryers: This signal is hardwired ON.</li> <li>• 4-Hd Gas Fryers: This signal is hardwired OFF and should never be present.</li> </ul> <p>The two sets of P &amp; M signals are interlocked by relays on the I/O board inside the controller. The controller cannot turn on the gas pilot valve unless both PV signals are present. The controller cannot turn on the gas main valve (main burners) unless both MV signals are present.</p> <p><b>F</b> = FAN - This is the Fan sensor (vacuum switch) interlock input. When ‘F’ is present, the vacuum sensor is closed (continuity). When ‘F’ is missing, the vacuum switch is open or is disconnected.</p> <p><b>P</b> = The PV (Pilot Valve) output from the ignition module. The ignition module turns PV on when it is trying to establish or maintain the pilot flame.</p> <p><b>M</b> = The MV (Main Valve) output from the ignition module. The ignition module turns MV on only when the module has a confirmed “flame sense” of its pilot flame. Keep in mind that the MV signals are simply “enabling” signals for the gas burners – the burners are not actually activated unless the controller turns the Heat output on.</p>
T-13 Outputs	<p>View/set the status of the controller outputs. If an output is currently on, a “star” follows the ID letter. If an output is currently off, a line follows the letter.</p> <p><b>F</b> = FAN OUTPUT  <b>I</b> = IGNITION MODULES OUTPUT  <b>H</b> = HEAT OUTPUT  <b>P</b> = PRESSURE OUTPUT</p> <p>The outputs may be manually controlled using the lighted number buttons. The #1 button toggles the first output on and off, the #2 button toggles the second output on and off, etc.</p>

Menu Step	Description
	<p>For example, on a Gas 4 Head fryer the #1 button toggles the Fan output on and off, while on an Electric 4 Head fryer, the #1 button toggles the Heat on and off.</p> <p>Under manual control, the Heat output will shut off automatically if no buttons are pressed for 30 seconds.</p> <p><b>4-Head Electric Fryers:</b>  OUTPUTS - F* H * P _  (Fan output only used on PVS fryers)</p> <p><b>4-Head Gas Fryers:</b>  OUTPUTS - F* H * P _  (Fan output is for cooling fan)</p>
T-13A Outputs	<p>View/set the status of the Pump and Air Valve outputs. If an output is currently on, a “star” follows the ID letter. If an output is currently off, a line follows the letter.</p> <p>PMP = PUMP OUTPUT  AIR = AIR VALVE OUTPUT</p> <p>The outputs may be manually controlled using the lighted number buttons. The #1 button toggles the Pump output on and off, and the #2 button toggles the Air Valve output on and off.</p>
T-14 Amps Calibrate	<p>If the Amp Sensor Detect Jumper in the amp sensors assembly is not detected, the controller shows “XX XX XX “ / “ -NOT- DETECTED” and all Amp Sensor warnings and errors are disabled.</p> <p><b>Electric 4 Head Fryers:</b>  The amp sensors monitor the current (amperes) in the heating elements. Depending on the fryer wiring, each amps reading corresponds to either the current in one leg of the supply lines, or to the current to one heating element coil.</p> <p>Consequently, the amps readings here don’t necessarily match the amps readings of an individual heater, since each leg on the line cord normally drives two elements (120° out of phase).</p> <p>Press the DOWN button to view the present Nominal, Low Limit, and High Limit settings for amps. (These values are programmed in Special Program mode.)</p> <p>This step allows manual control of the heat output by pressing the #1 button. The heat is turned on unconditionally, so make sure there is oil in the vat (frypot) and take care to not overheat it.</p> <p>Press the #0 button to view the un-calibrated readings.</p> <p><b>Calibration:</b>  Press the TIMER button to perform the calibration sequence, which allows each of the three readings to be adjusted to match reference amp readings. This calibration requires a meter with an amp clamp to take readings at each of the three amp sensors in the fryer.</p> <p>During the calibration sequence, one of the readings is blinking. Use the UP and DOWN buttons to adjust that reading as necessary. Press the PROG button to advance to the next reading.</p> <p>The displayed values, left to right, match the amp sensor order black, red, and orange. For each amp sensor, the displayed value should be adjusted to match a reading taken with an amp clamp on the same wire the amp sensor is on.</p>

Menu Step	Description
	<p>When done calibrating, press the TIMER button to cancel the calibration sequence, or press the PROG button repeatedly until the calibration sequence is exited.</p>
<p>T-15 Change Tech Code?</p>	<p>1 = YES            This step lets you change the “Tech Mode” access code (password). This code is used only to access Tech Mode and Stats Mode.  <b>IF THE PASSWORD IS CHANGED &amp; FORGOTTEN:</b>            There is a way to “unlock” a controller whose password has been forgotten. Contact Tech Services for details.            To change the selected code, press the ‘1’ button (i.e.1=“YES”).            The display shows: “ENTER NEW CODE” _____            “P=DONE”            “I = QUIT”            Enter the new code sequence - comprised of one to eight keystrokes – using the number buttons 1 through 0. When the new code sequence is complete, press the [P] (PROG) button.            The display now shows: “REPEAT NEW CODE” _____            “P=DONE”            “I = QUIT”            Enter the new code sequence a second time in the same manner as the first. Again, press the [P] (PROG) button when the entry is complete. If the same key sequence is entered both times, the controller responds “*CODE CHANGED*”. From this point on, the new code sequence is required for access to Tech Mode functions. The previous code is erased and is no longer valid.            If the first and second entries do not match exactly, the controller indicates “DID NOT MATCH”, “NOT CHANGED”. In this case, the access code will not be changed – the previous value remains in effect.            The code entry process may be abandoned at any point by pressing the “I” (INFO) button. The display immediately shows “X CANCELLED X” and returns to the initial “Change Code?” display. The previous code remains in effect.            If no keys are pressed for 30 seconds, the entry process is automatically abandoned. The display shows “X CANCELLED X” and the previous code value remains in effect.</p>

Menu Step	Description
T-16 Do Total Init	<p>This step allows all programmable settings, all product settings, and all statistics values to be initialized to factory preset values. (The Activity Log, however, is not reset by this initialization, and in fact will log a record of the “init” function itself.)</p> <p>To totally initialize the controller – including all cook settings – back to factory default values, press and hold the DOWN button for about 2 seconds.</p> <p>Calibration data will not be affected by this initialization, unless values are found to be outside of acceptable limits.</p> <p style="text-align: center;"><b>NOTICE</b></p> <p>Statistics values, the Error Log, Review Usage data, etc., will be reset by this “total” initialization. All of the operating history data will be lost. For this reason, the normal “Init” step in Special Program mode is generally recommended, unless one specifically intends to completely reset all the statistics data.</p>



# Chapter 7 Wiring Diagrams

## 7.1 600 GF, 120v, 60Hz, 1P, STD IGN (63240H)

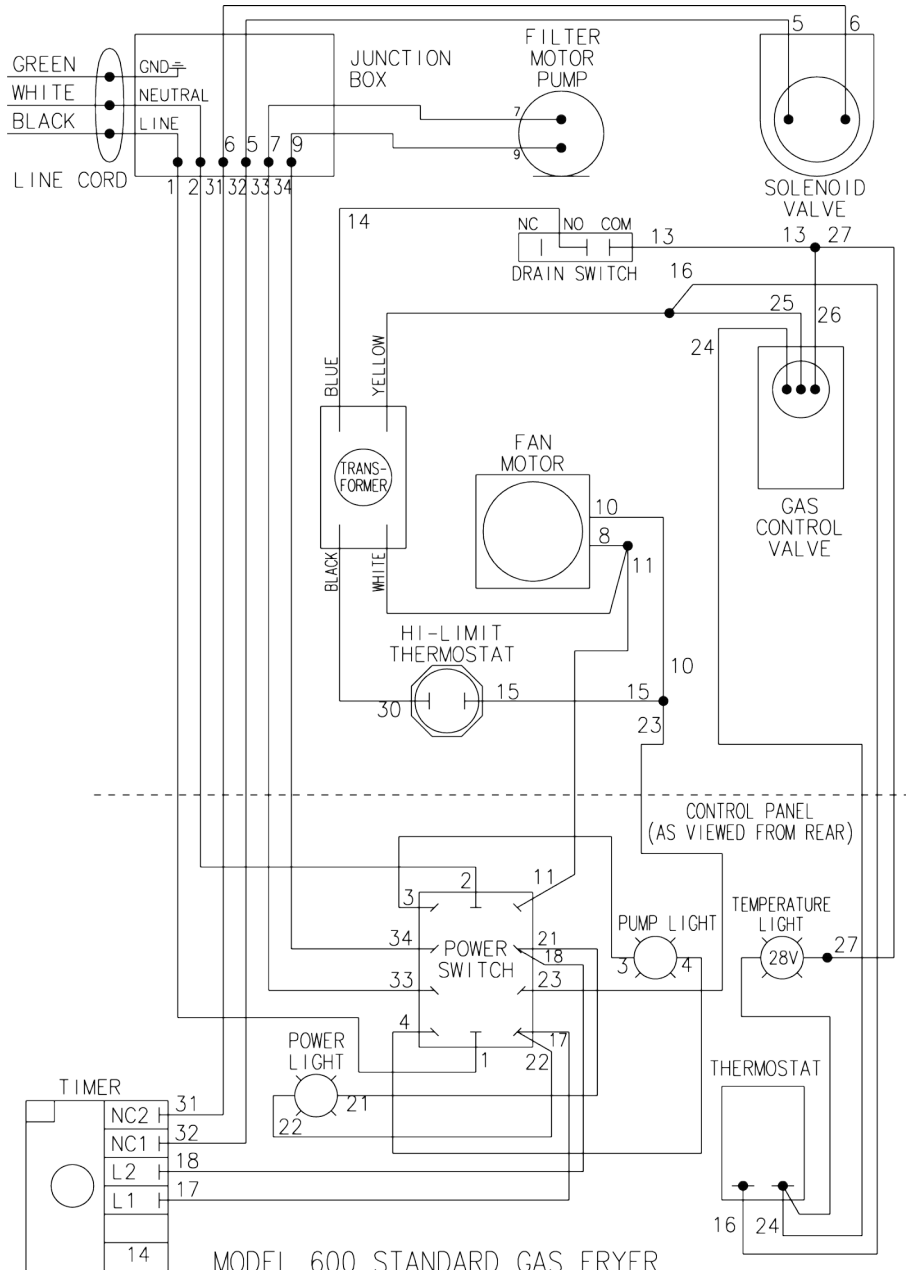

MODEL 600 STANDARD GAS FRYER  
 120V 60Hz 1PH  
 STANDARD IGNITION  
 HENNY PENNY CORP., EATON, OHIO 45320 63240

## 7.2 600 GF, 240v, 50Hz, 1P, SI (55318A)

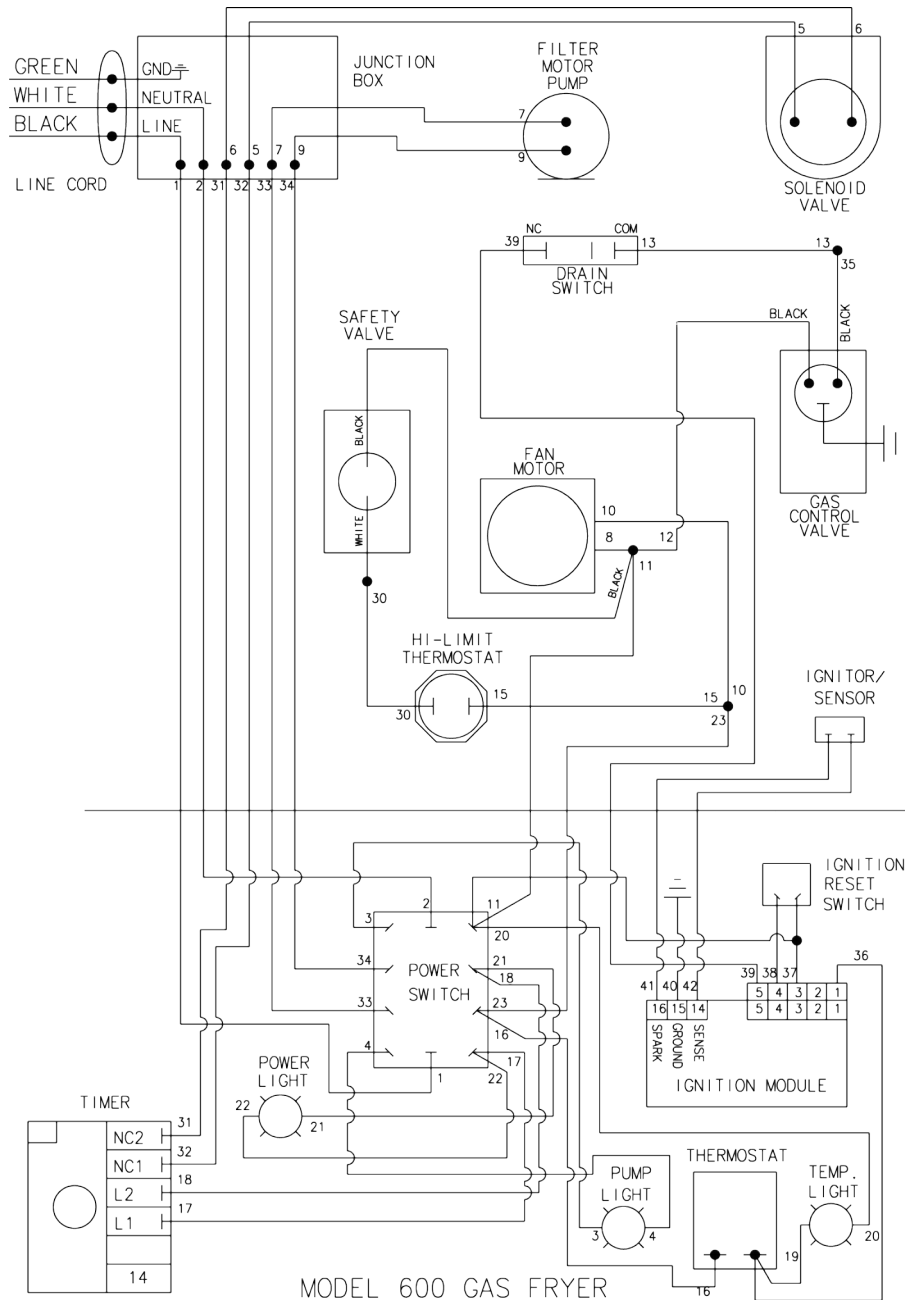

MODEL 600 GAS FRYER  
240V, 50Hz, 1 PHASE  
SPARK IGNITION

55318

## 7.3 600 GF, 120v, 60Hz, 1P, EI (34389C)

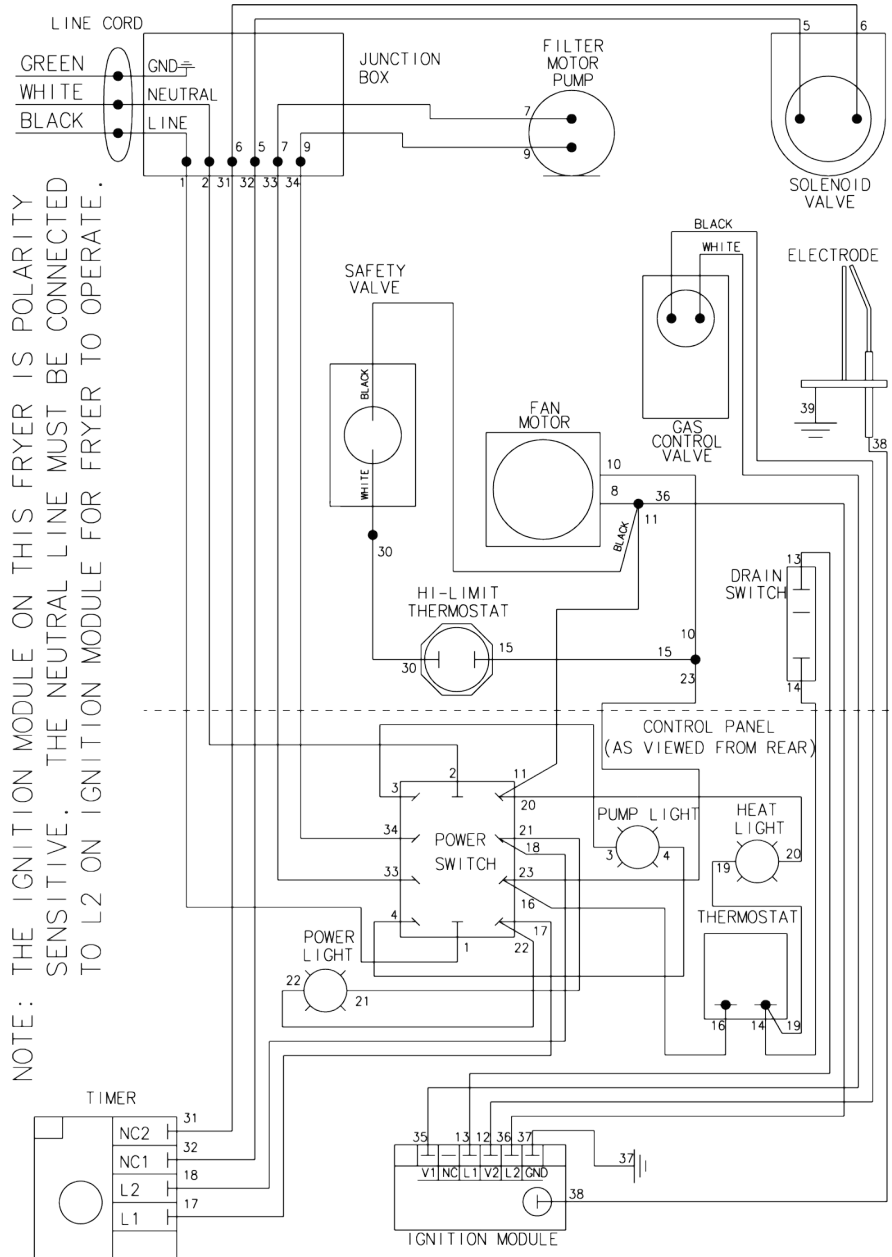

MODEL 600 STANDARD GAS FRYER  
 120 VOLT 60 HZ 1 PHASE  
 ELECTRONIC IGNITION

34389

# 7.4 600 GF, 120-240v, 50/60Hz, 1P, STD IGN (63694L) (Before AN0702112)

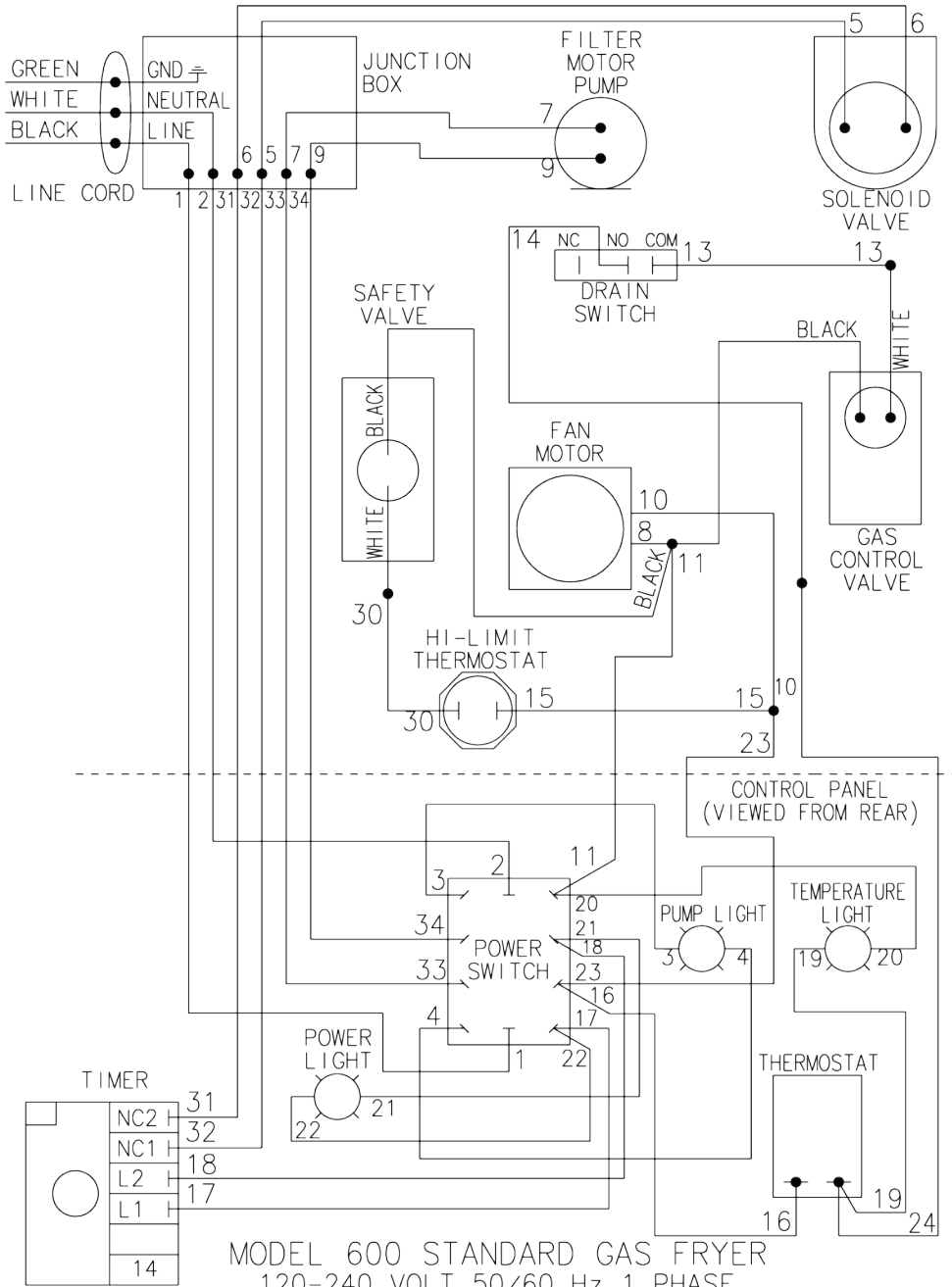

MODEL 600 STANDARD GAS FRYER  
120-240 VOLT 50/60 Hz 1 PHASE  
STANDARD IGNITION

63694

# 7.5 600 GF, 120-240v, 50/60Hz, 1P, ESI (7555B) (AN0703021-11029-Shaw)

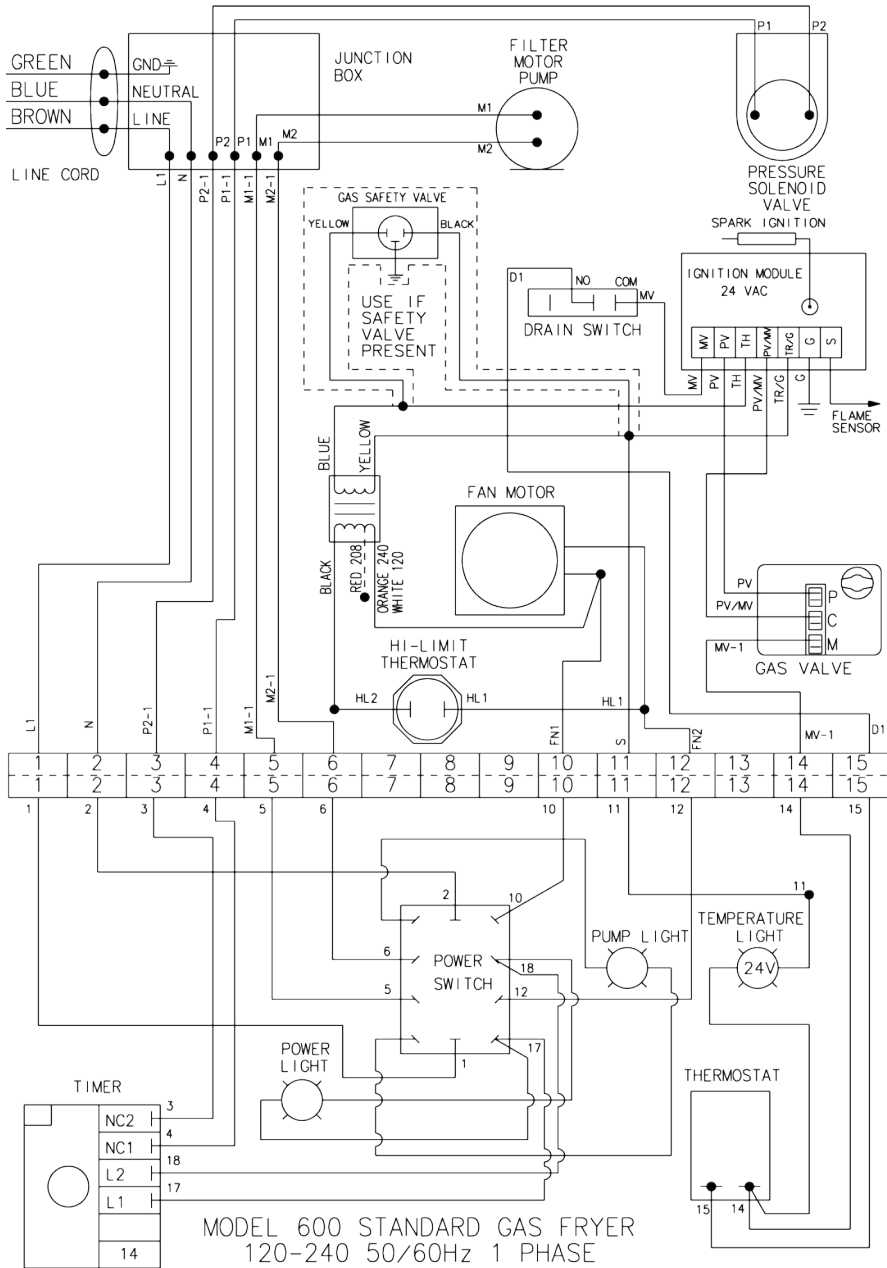

MODEL 600 STANDARD GAS FRYER  
120-240 50/60Hz 1 PHASE  
HENNY PENNY CORP.  
EATON, OHIO 45320  
ELECTRONIC SPARK IGNITION

75555

# 7.6 600 GF, 120-240v, 50/60Hz, 1P, ESI (7555E) (After AN0703021-Fenwal)

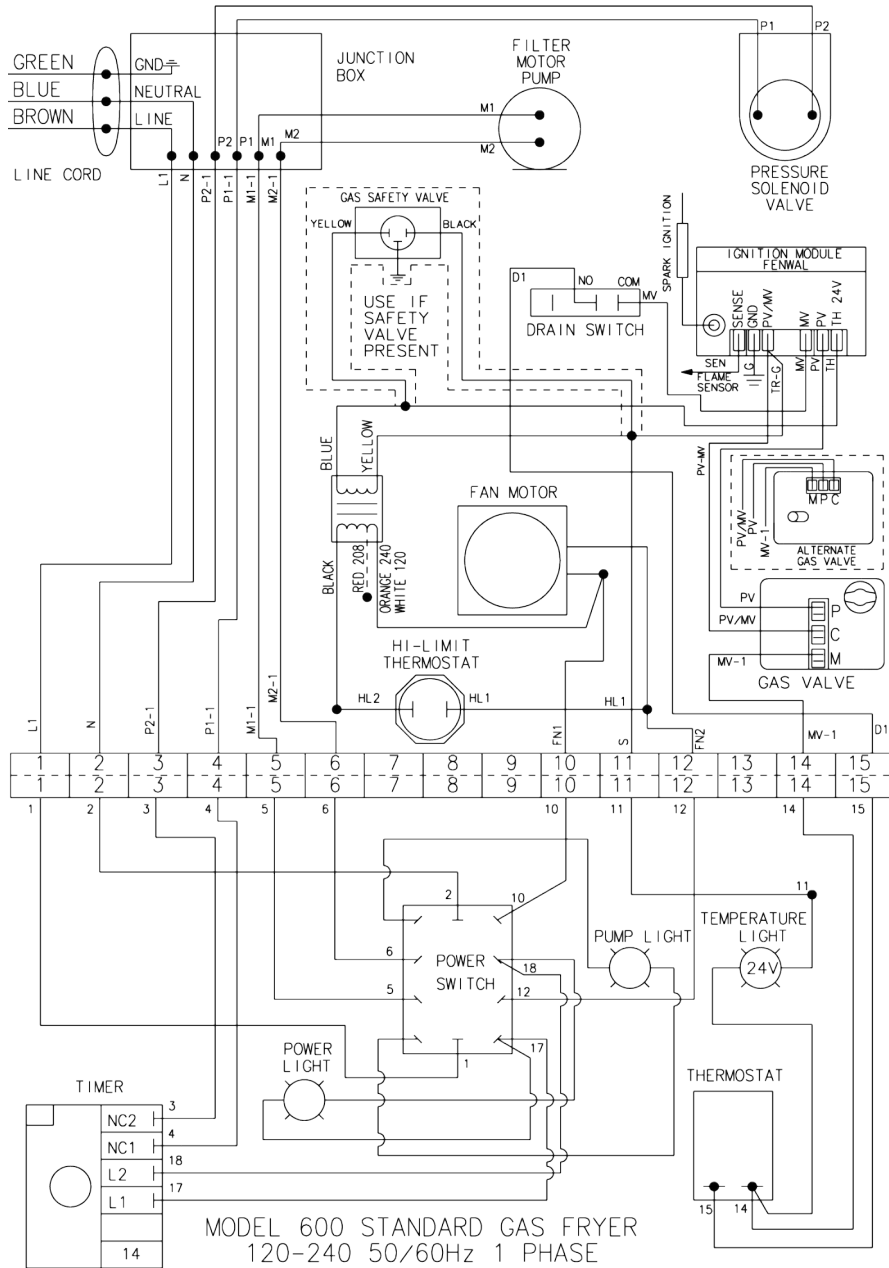

MODEL 600 STANDARD GAS FRYER  
120-240 50/60Hz 1 PHASE  
HENNY PENNY CORP.  
EATON, OHIO 45320  
ELECTRONIC SPARK IGNITION

75555

# 7.7 600 GF, 120v, 50/60Hz, 1P, ESI (67152C) (After AN0703021 use 75555)

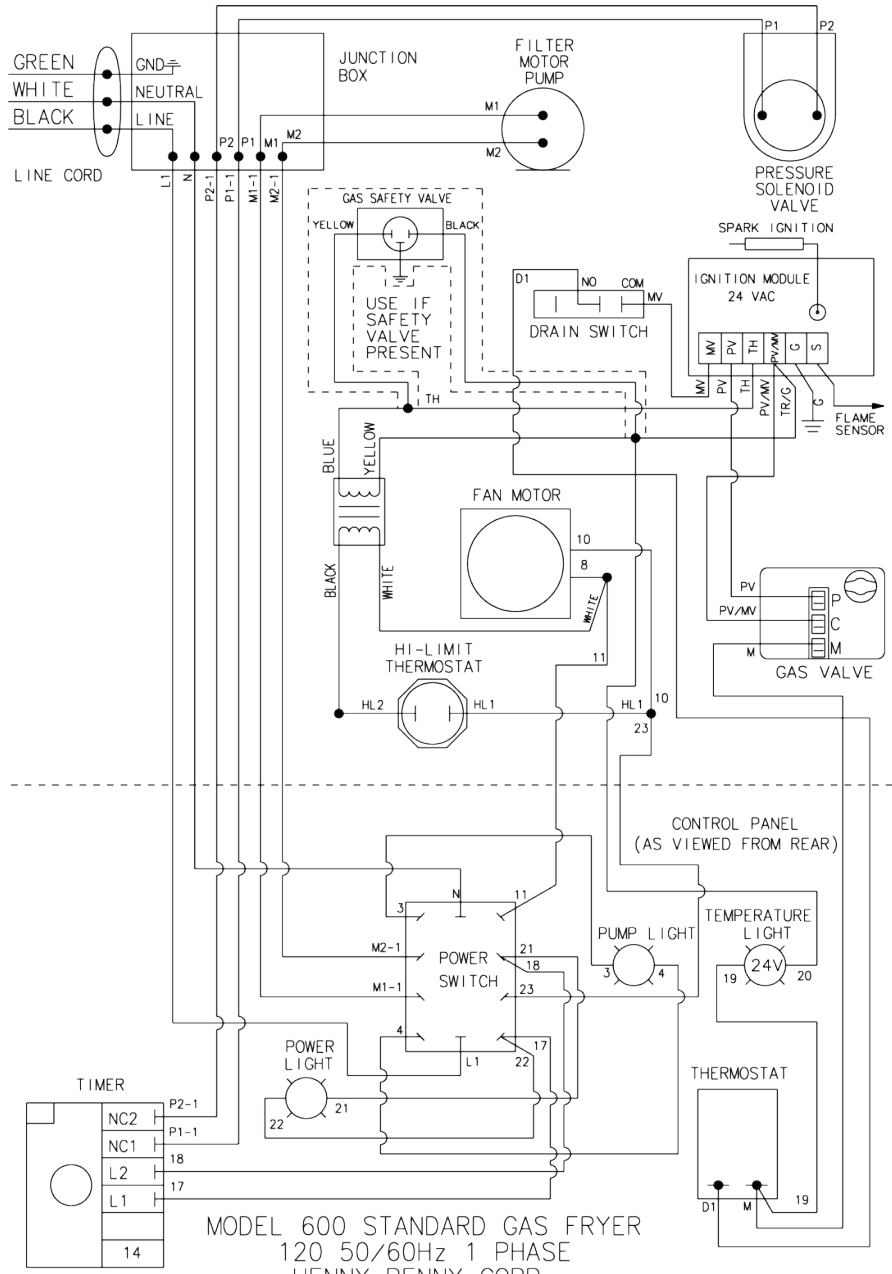

MODEL 600 STANDARD GAS FRYER  
 120 50/60Hz 1 PHASE  
 HENNY PENNY CORP.  
 EATON, OHIO 45320  
 ELECTRONIC SPARK IGNITION

67152

# 7.8 600 GF, 208-240v, 50/60Hz, 1P, ESI (69076C) (After AN0703021 use 75555)

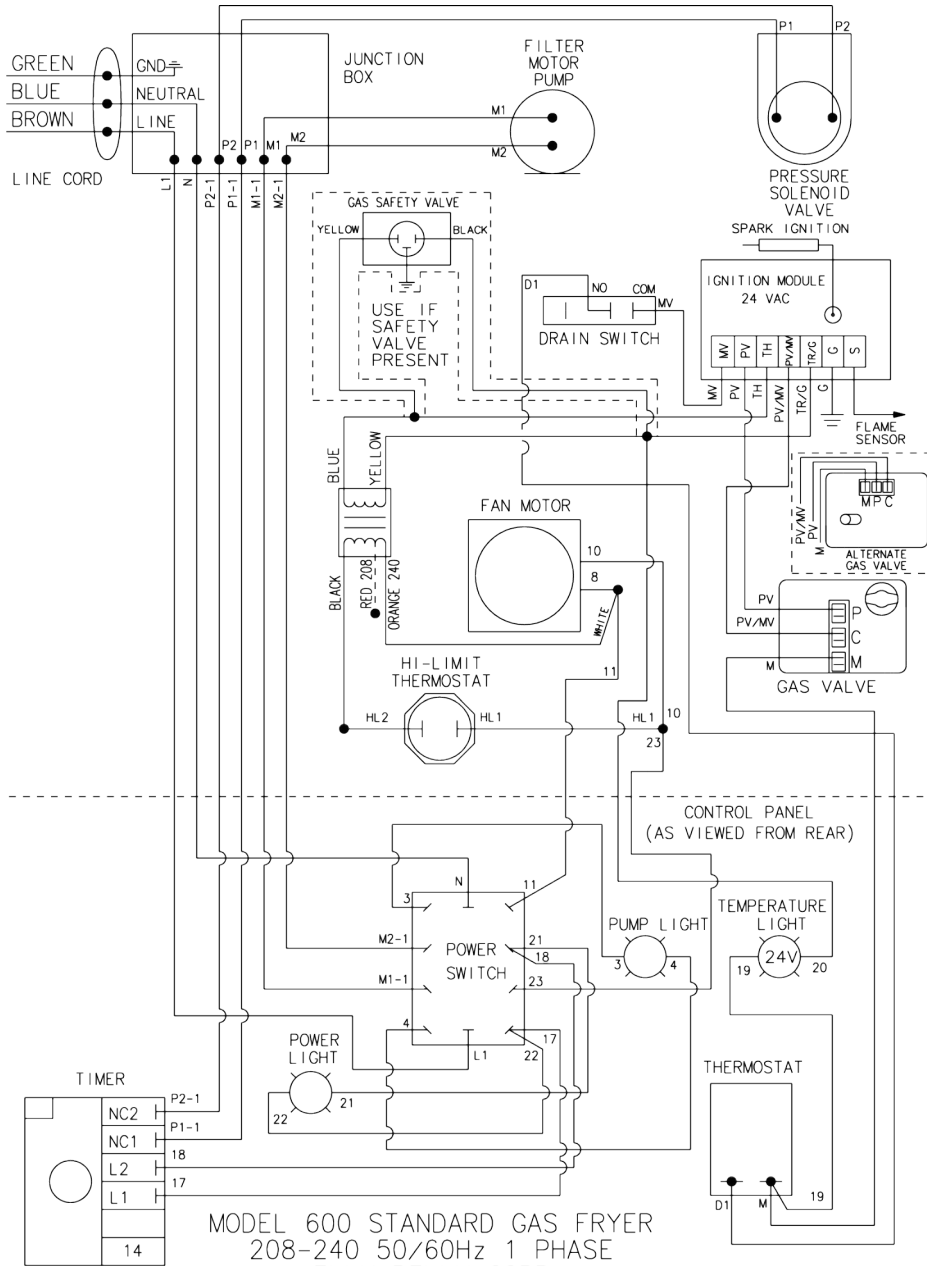

MODEL 600 STANDARD GAS FRYER  
208-240 50/60Hz 1 PHASE  
HENNY PENNY CORP.  
EATON, OHIO 45320  
ELECTRONIC SPARK IGNITION

69076

# 7.9 600 GF, 230v, 50Hz, 1P (34807K) (Before AN0702112)

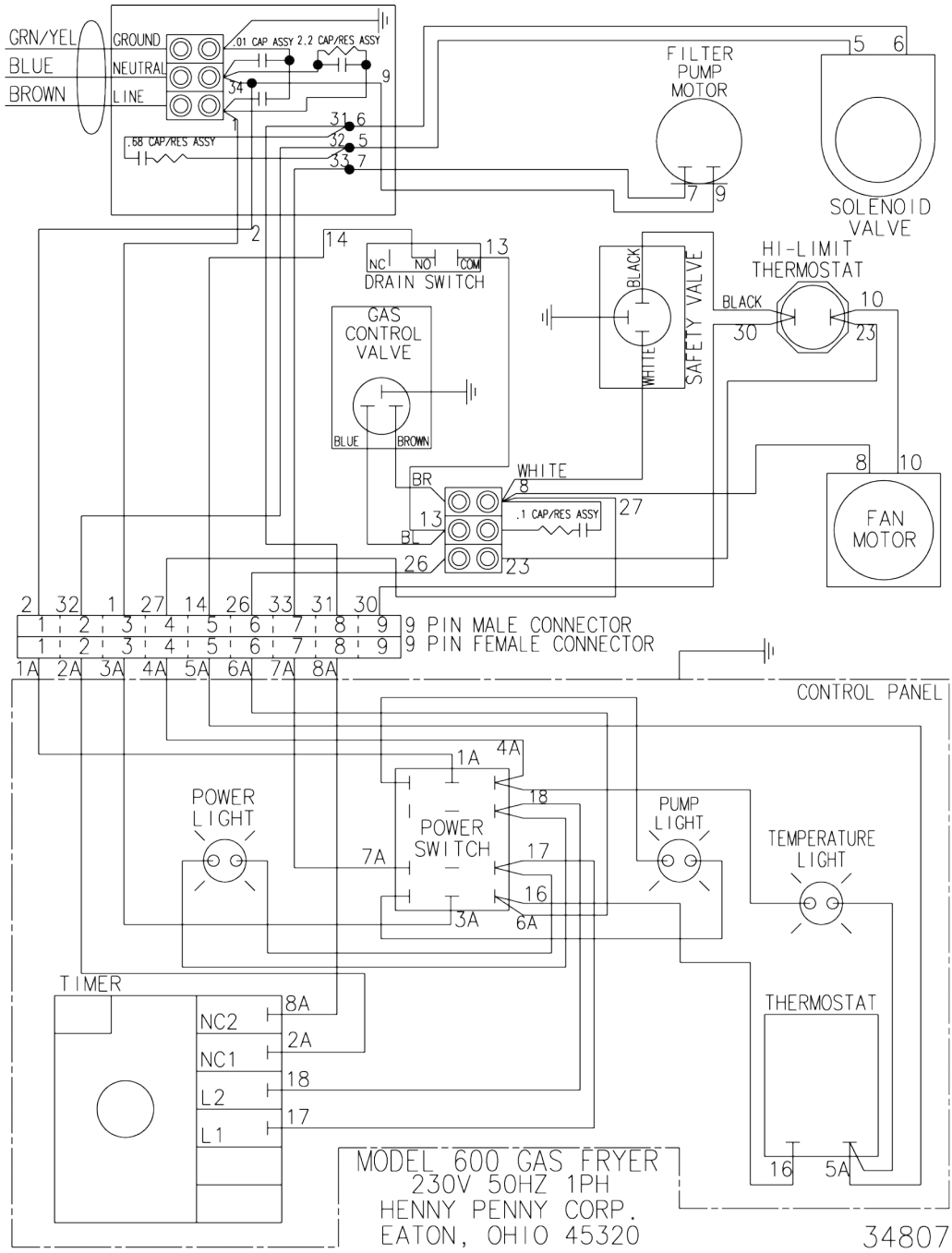

## 7.10 600 GF, 230v, 50Hz, 1P, SSI (75556B) (AN0703021-711029-Shaw)

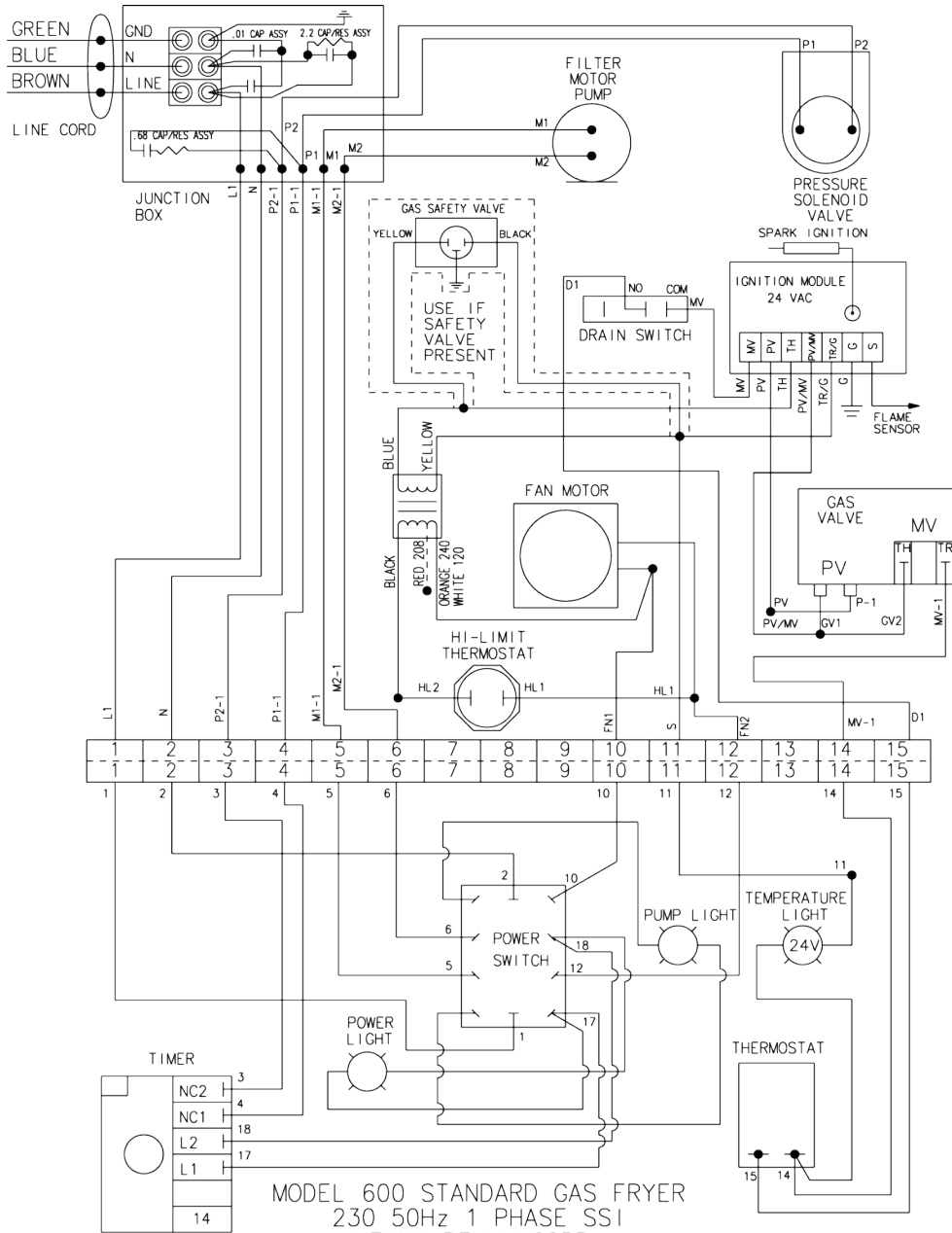

75556

# 7.11 600 GF, 230v, 50Hz, 1P, SSI (75556D) (After AN0711030-Fenwal)

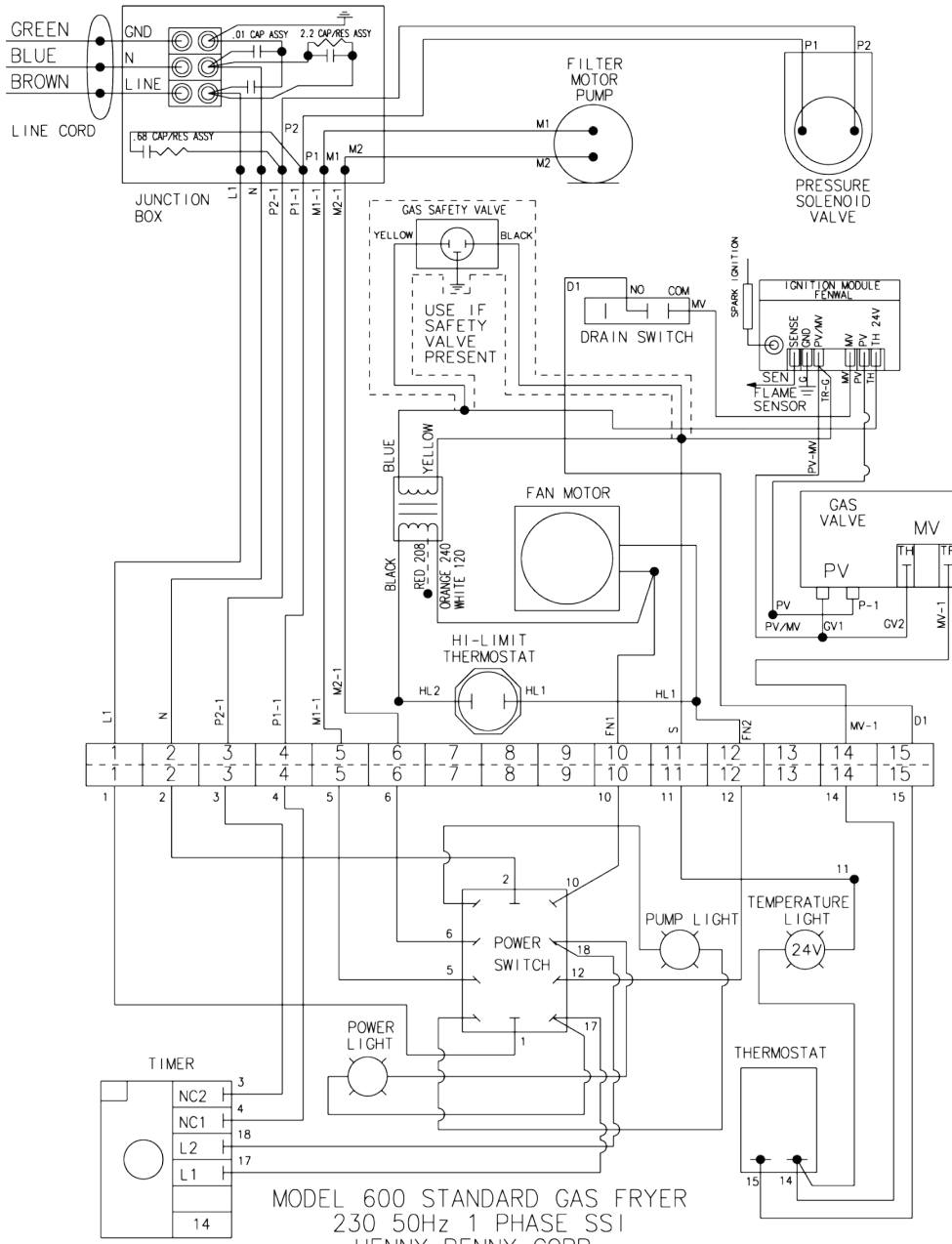

MODEL 600 STANDARD GAS FRYER  
 230 50Hz 1 PHASE SSI  
 HENNY PENNY CORP.  
 EATON, OHIO 45320

75556



# 7.13 600 GF, C1000 & 2000, 230v, 50Hz, 1P, 24v, 24v SSI (80221B)

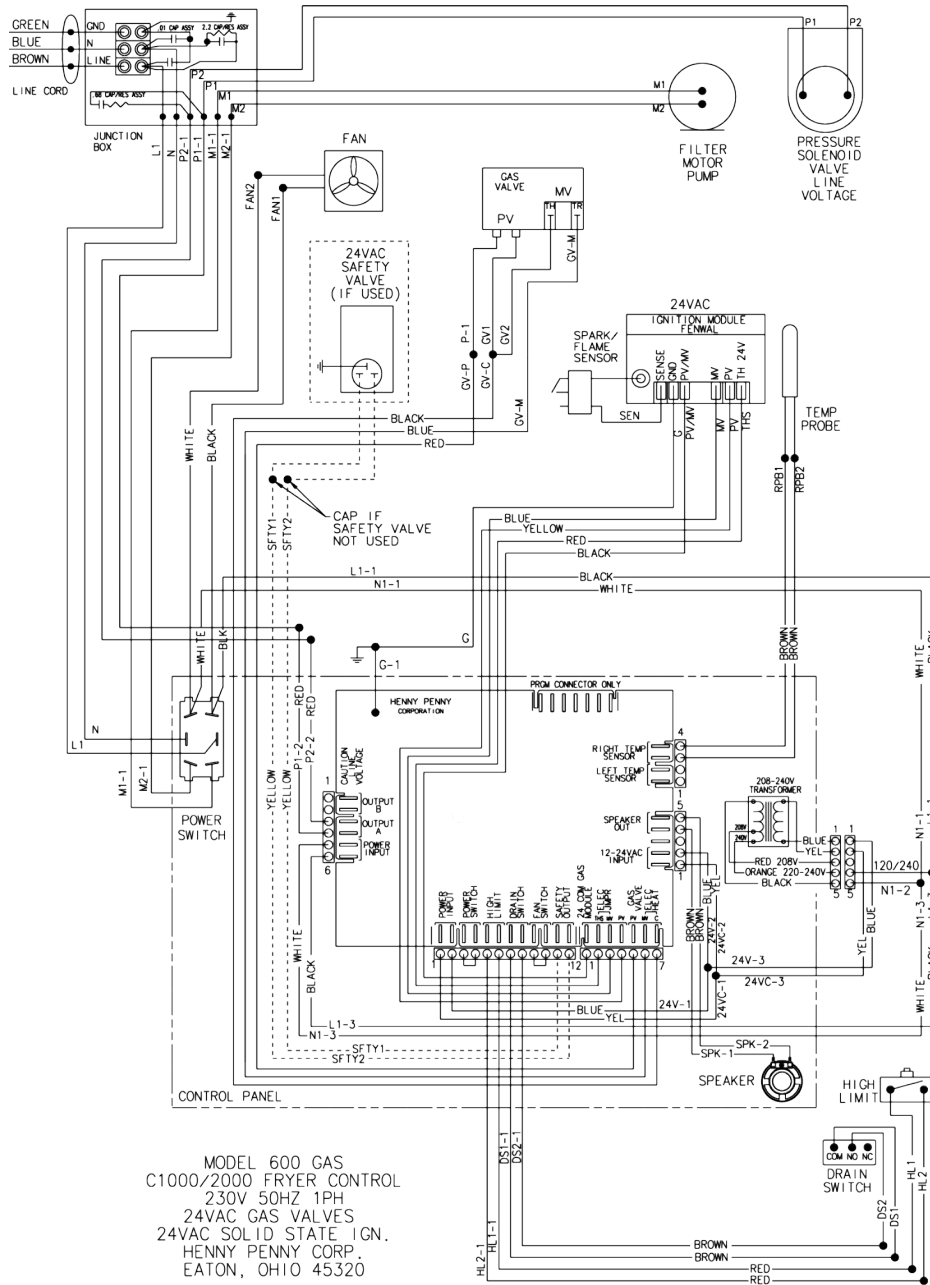

80221

## 7.14 600 EF, LVC, 120v, 50/60Hz, 1P (68598B)

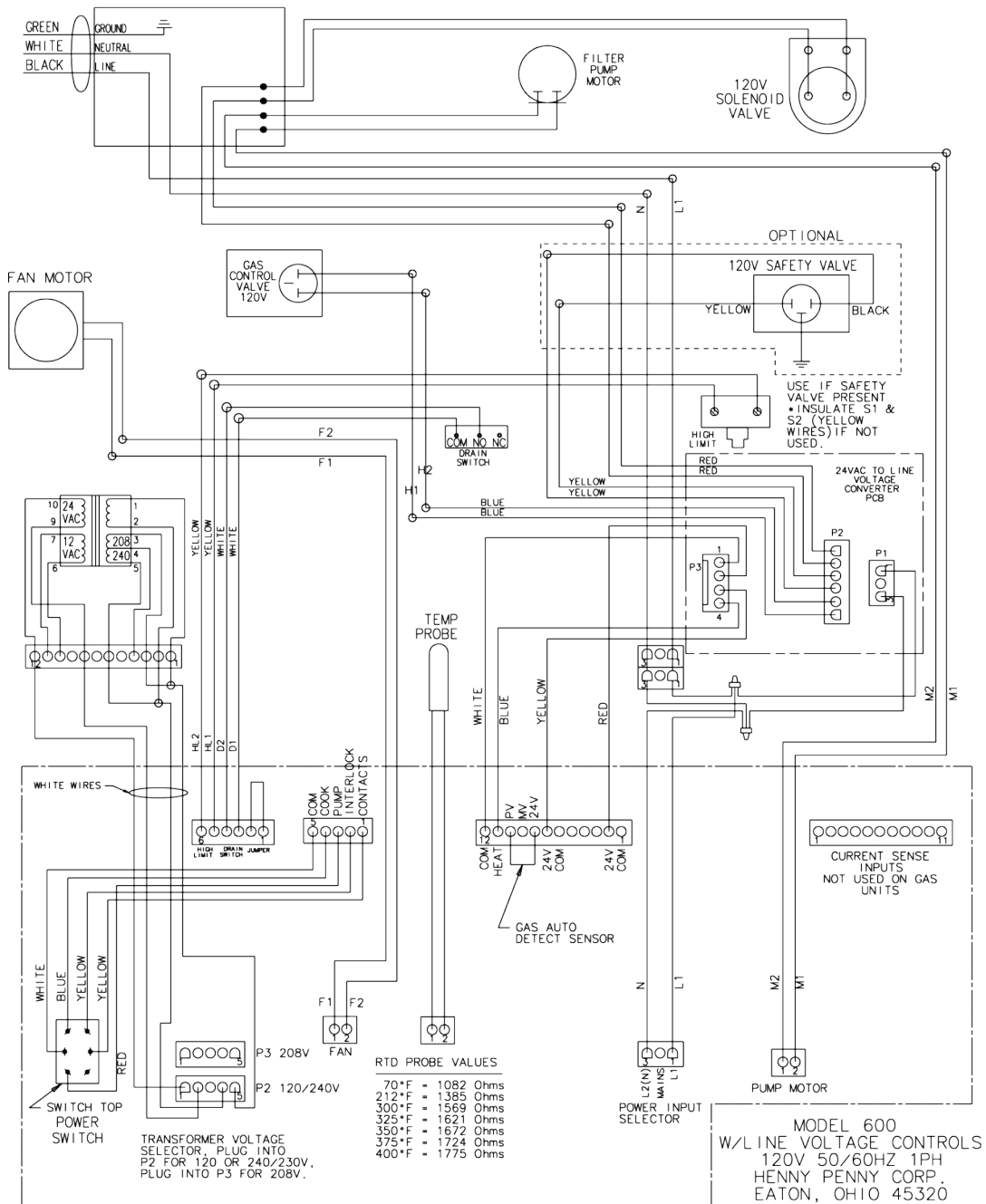

# 7.15 600 C/C EF, 120v, 50/60Hz, 1P, Wendy's FPS, ESI (67199G) (AN0703021-711029-Shaw)

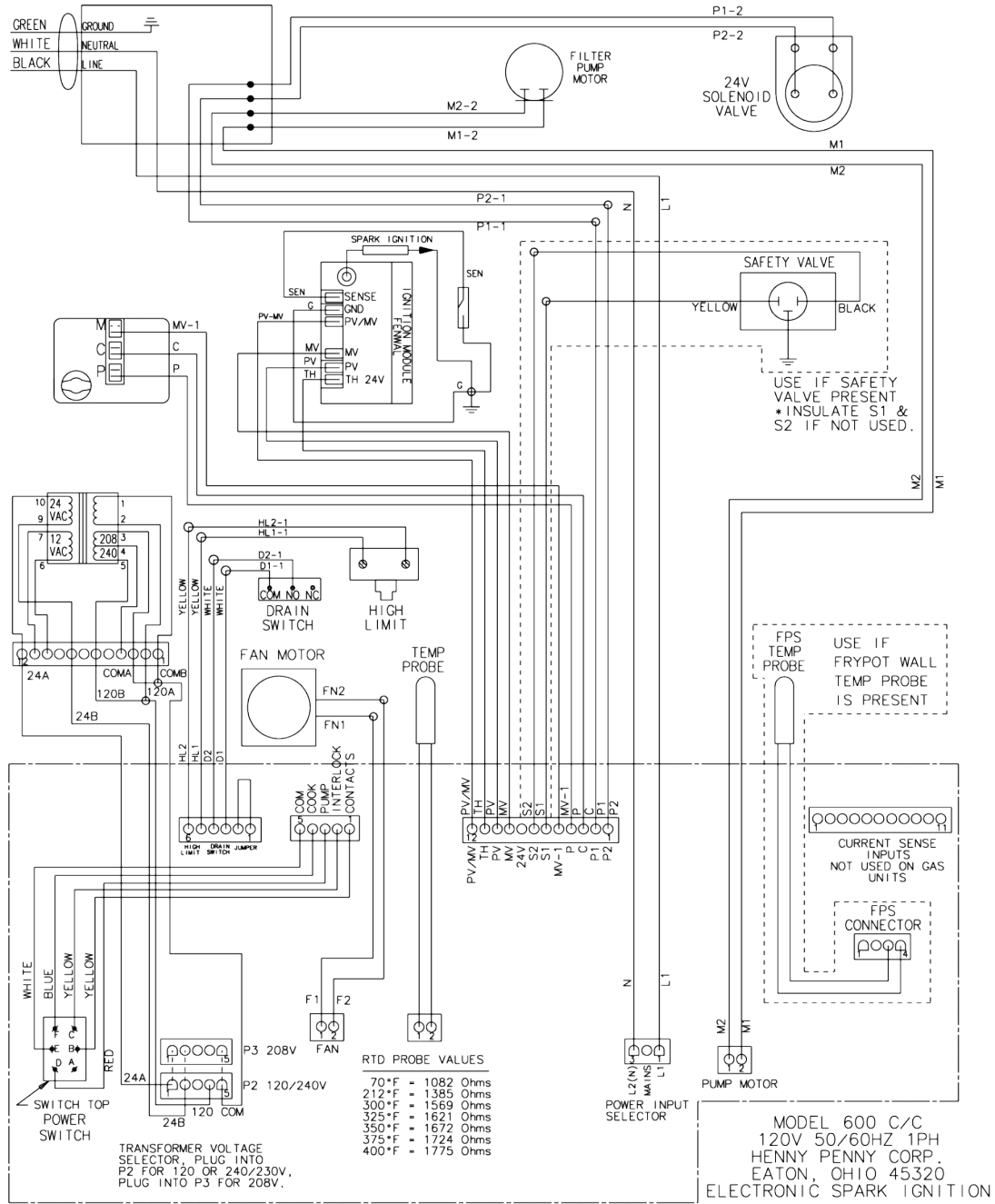

67199

# 7.16 600 C/C EF, 120v, 50/60Hz, 1P, ESI (67199J) (After AN0711030-Fenwal)

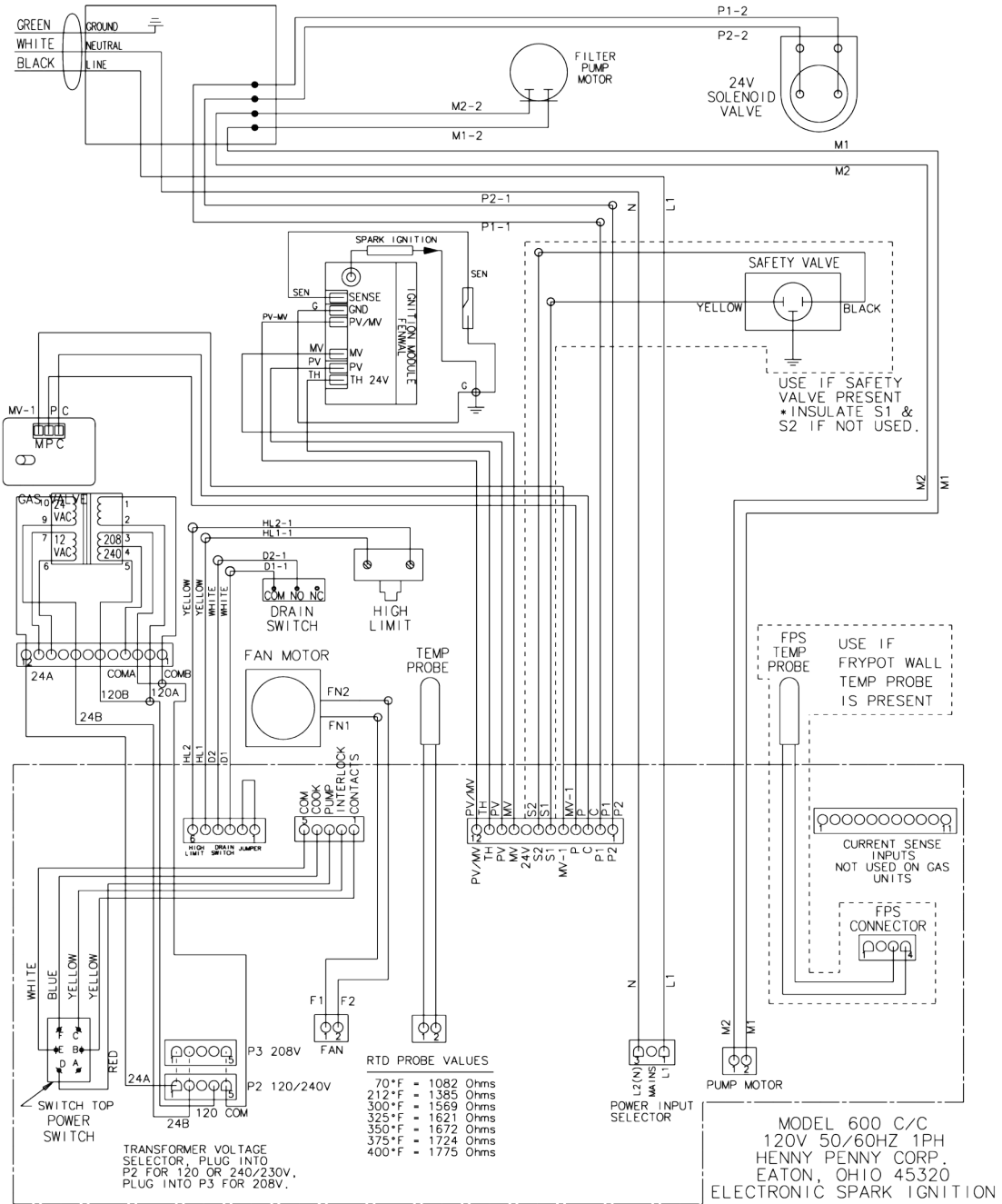

67199

# 7.17 600 C/C EF, 208-240v, 50/60Hz, 1P (32759G)

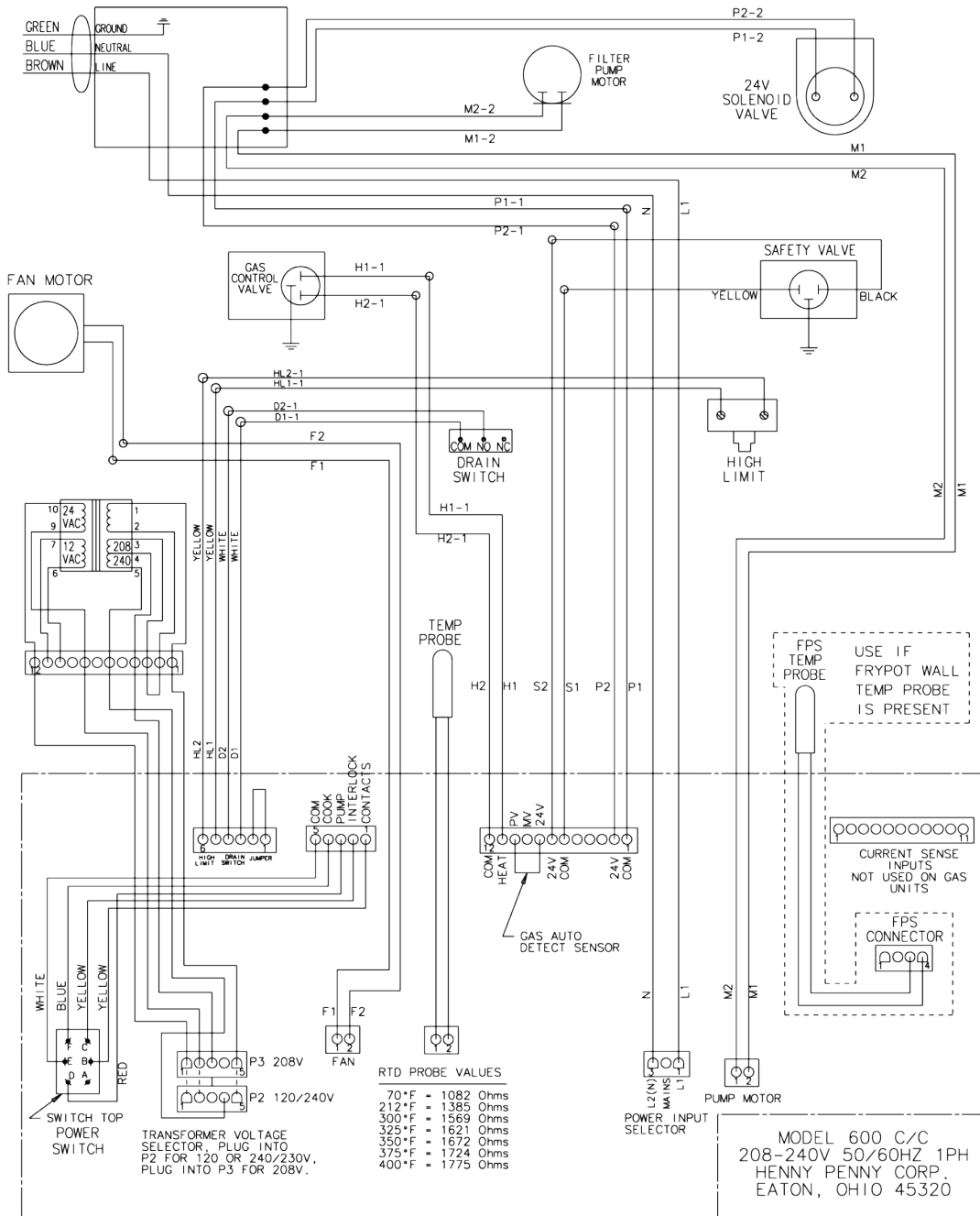

32759

# 7.18 600 C/C EF, 208-240v, 50/60Hz, 1P, ESI (67204E)

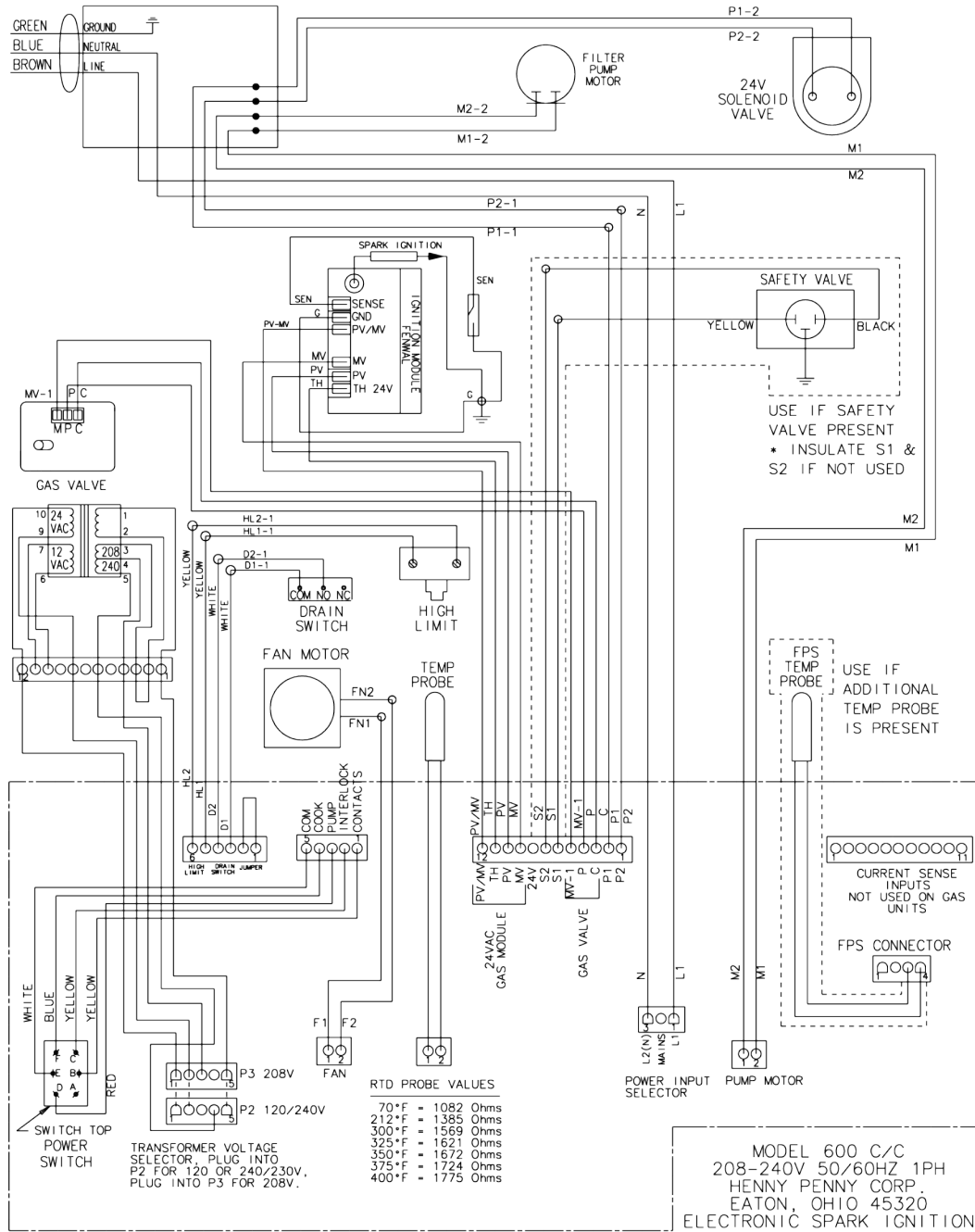

# 7.19 600 C/C EF, LVC, 208-240v, 50/60Hz, 1P (68614B)

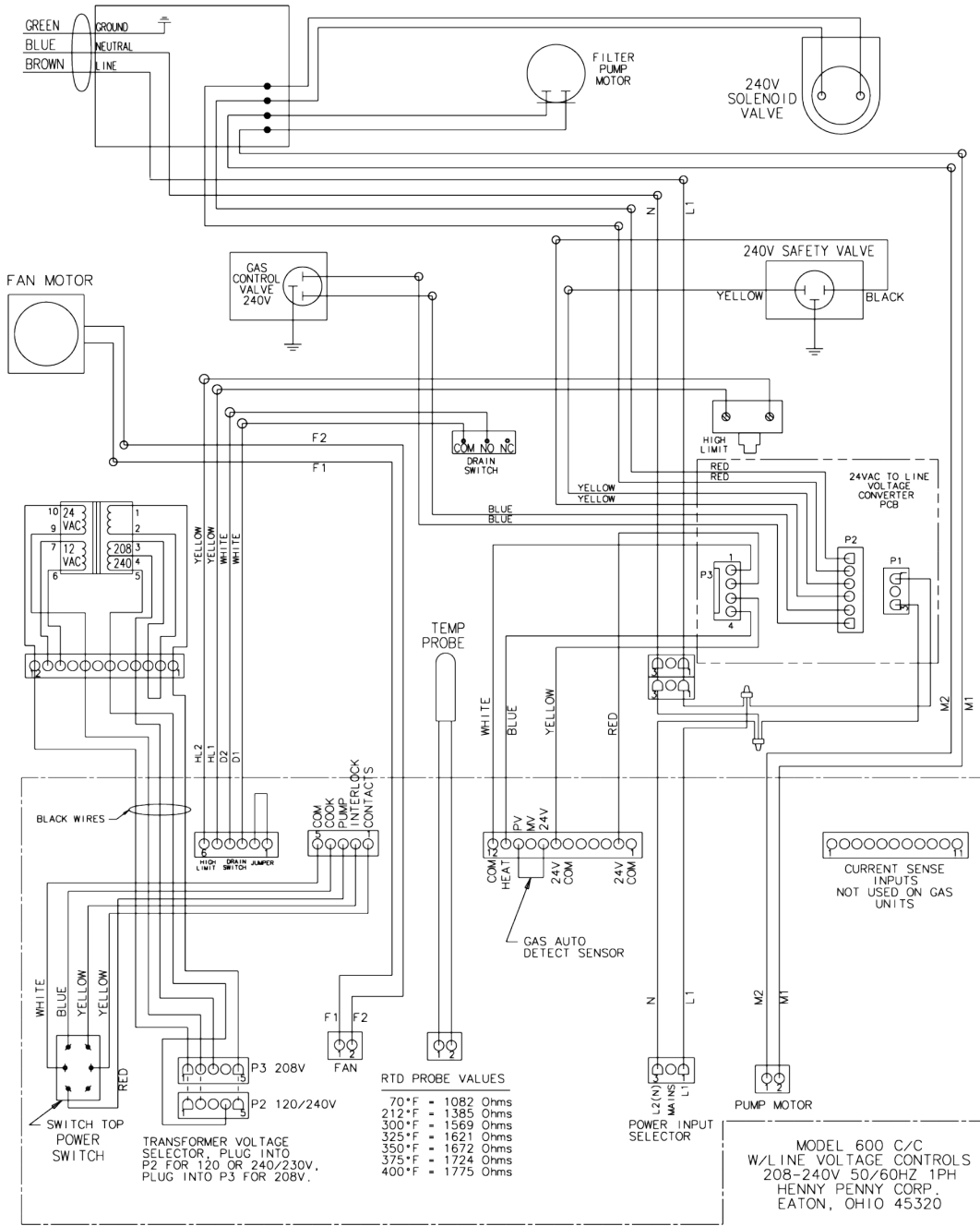

68614



# 7.21 600 GF, 100-240v 50/60 Hz, 1P (63357N) (Before AN0702112)

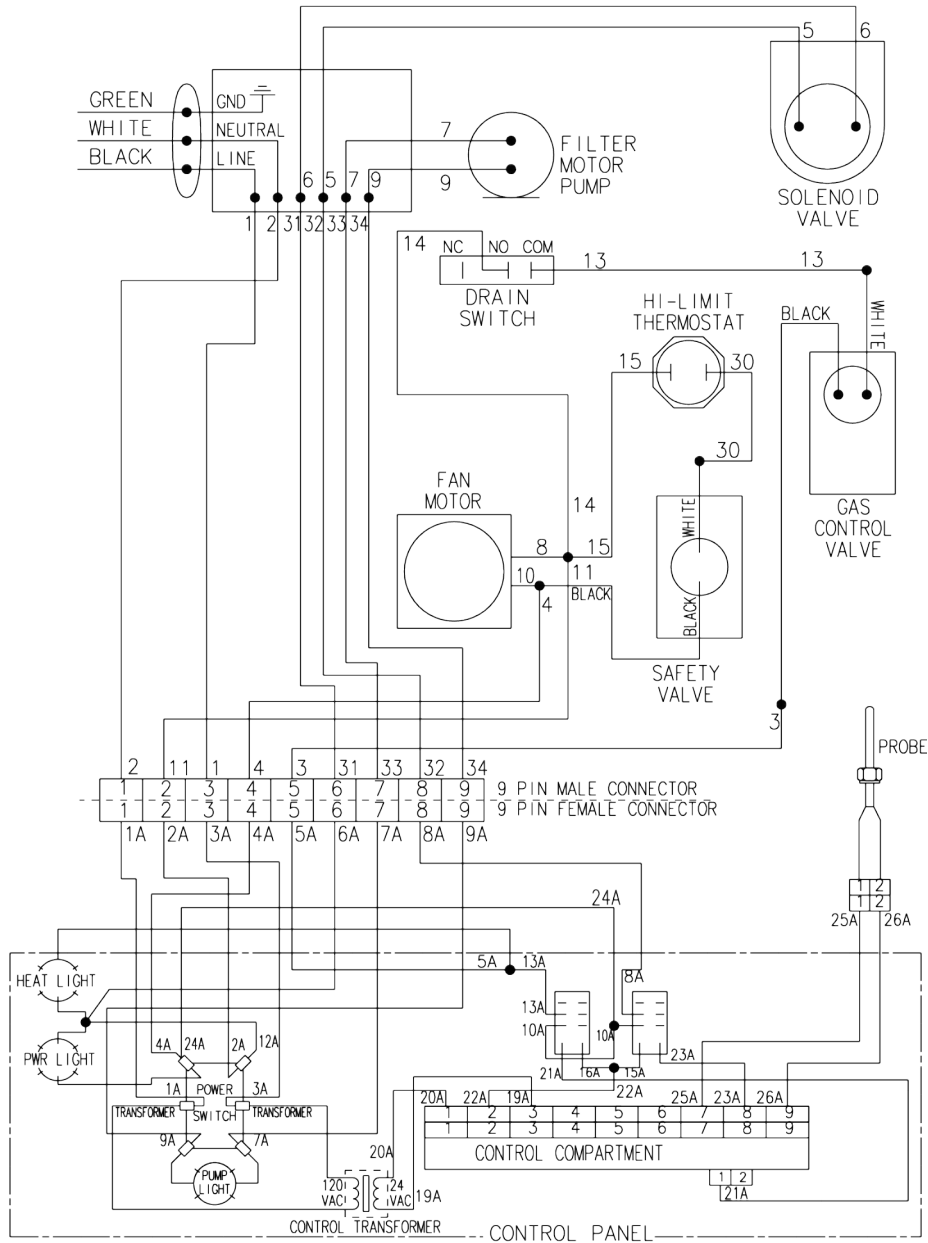

MODEL 600F  
 100-240V 50/60Hz 1PH  
 HENNY PENNY CORP., EATON, OHIO 45320

63357

# 7.22 600 GF, 100-240v 50/60 Hz, 1P, SSI (75510C) (AN0703021-0711029-Shaw)

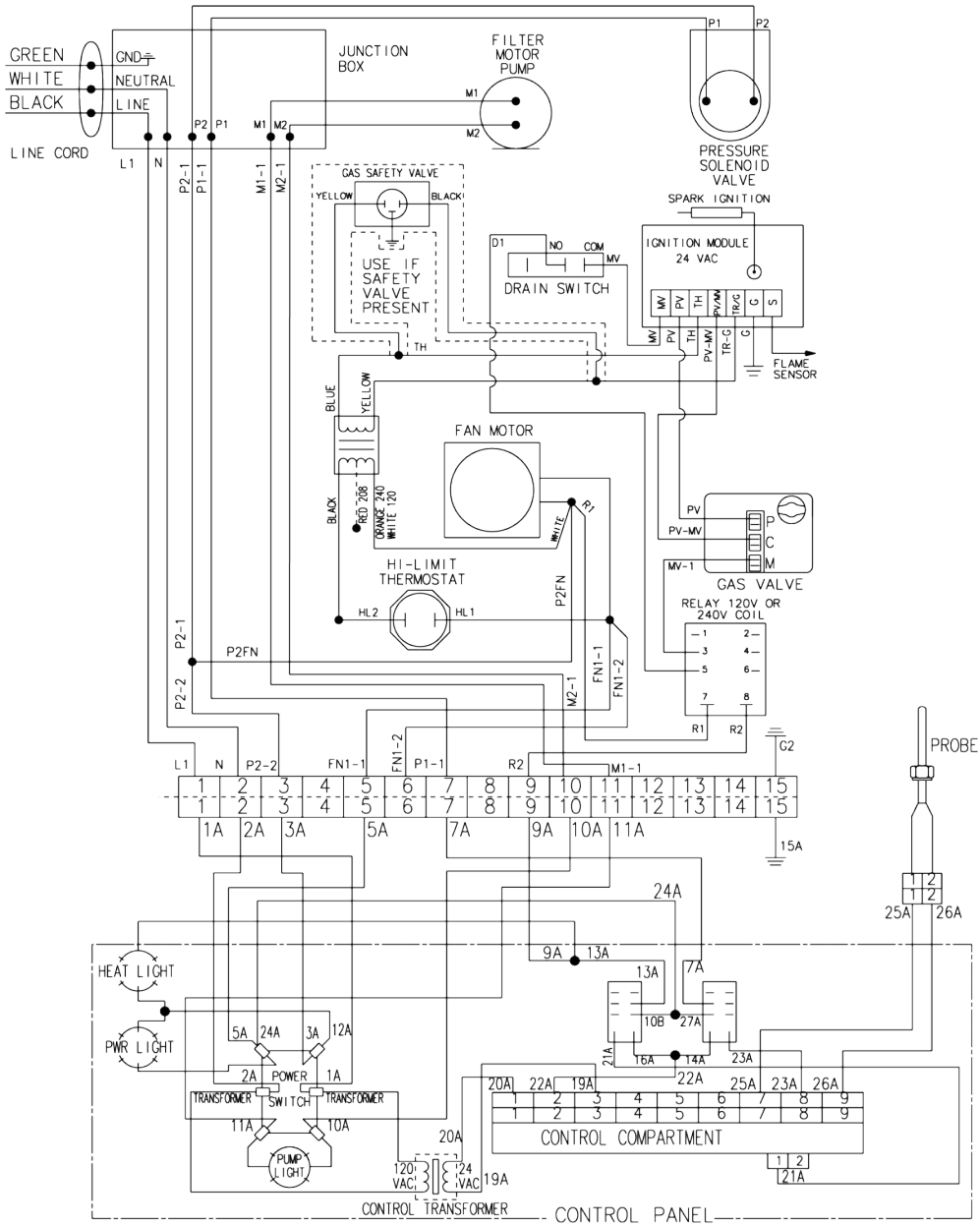

MODEL 600F  
100-240V 50/60Hz 1PH SSI  
HENNY PENNY CORP., EATON, OHIO 45320

75510

# 7.23 600 GF, 100-240v, 50/60Hz, 1P, SSI (75510) (After AN0711030-Fenwal)

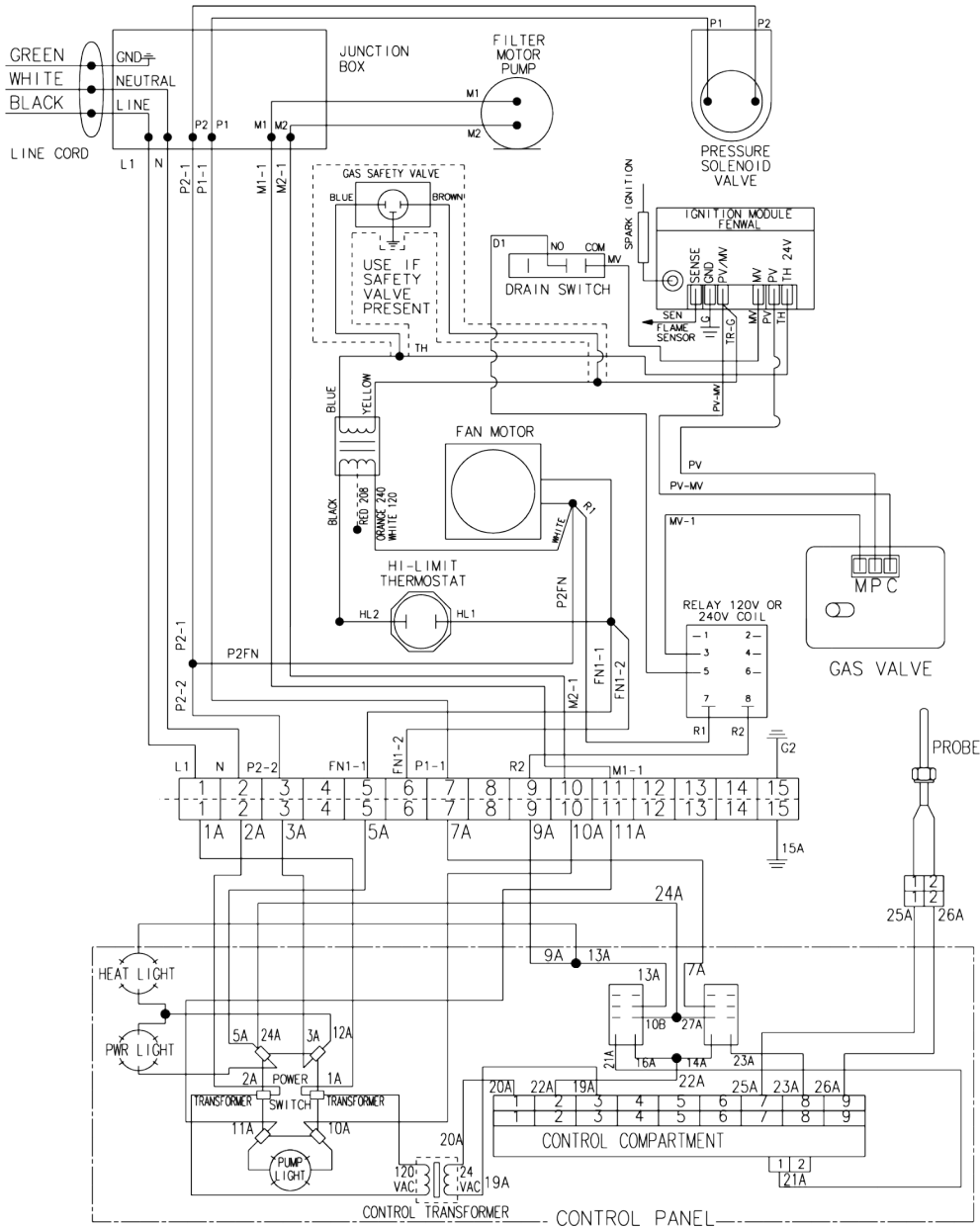

MODEL 600F  
100-240V 50/60Hz 1PH SSI  
HENNY PENNY CORP., EATON, OHIO 45320 75510\_F



# 7.25 600 EF, 230v, 50/60Hz, 1P, SSI (75511C) (AN0703021-0711029-Shaw)

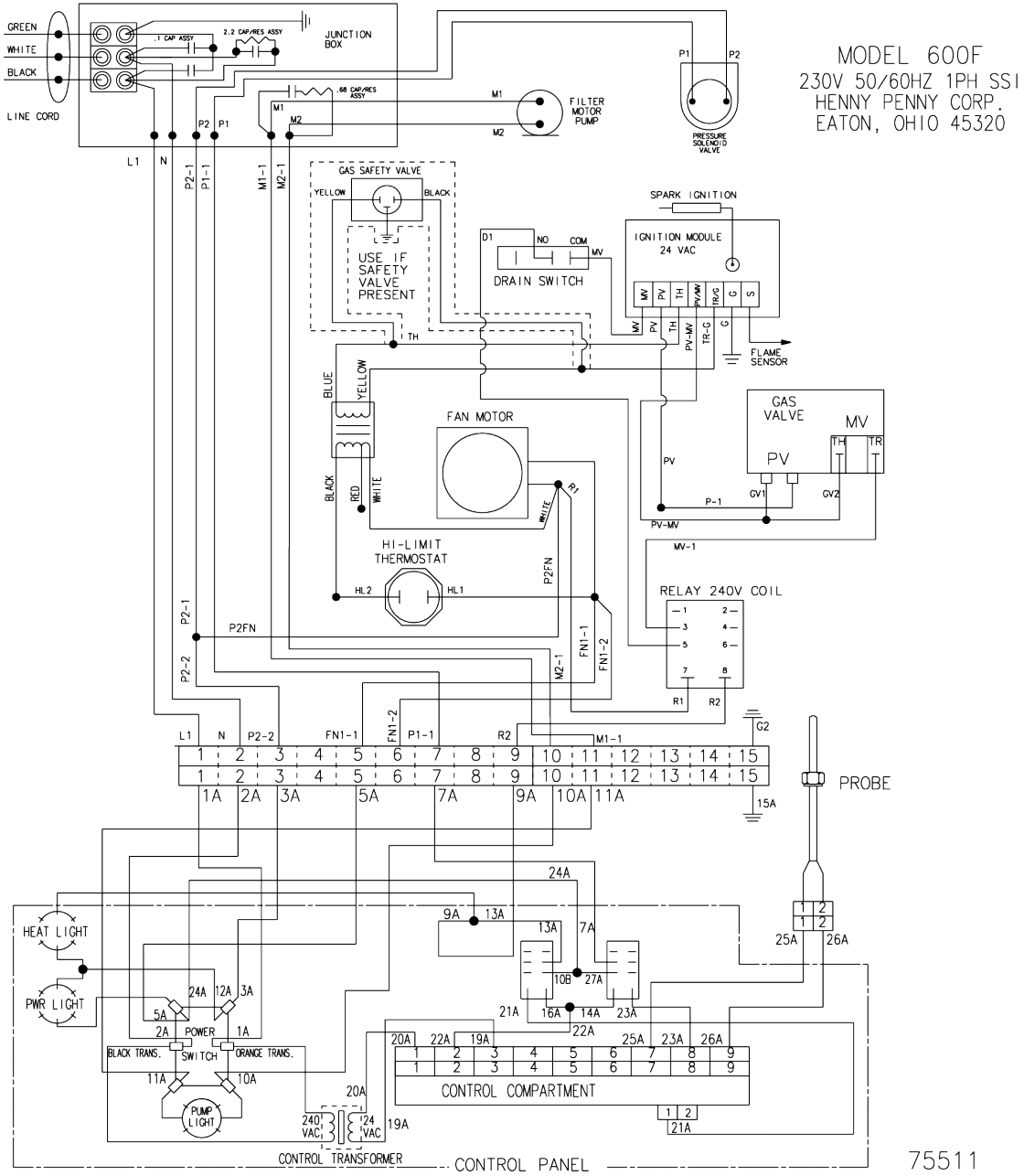

75511

# 7.26 600 EF, 230v, 50/60Hz, 1P, SSI (75511F) (After AN0711030-Fenwal)

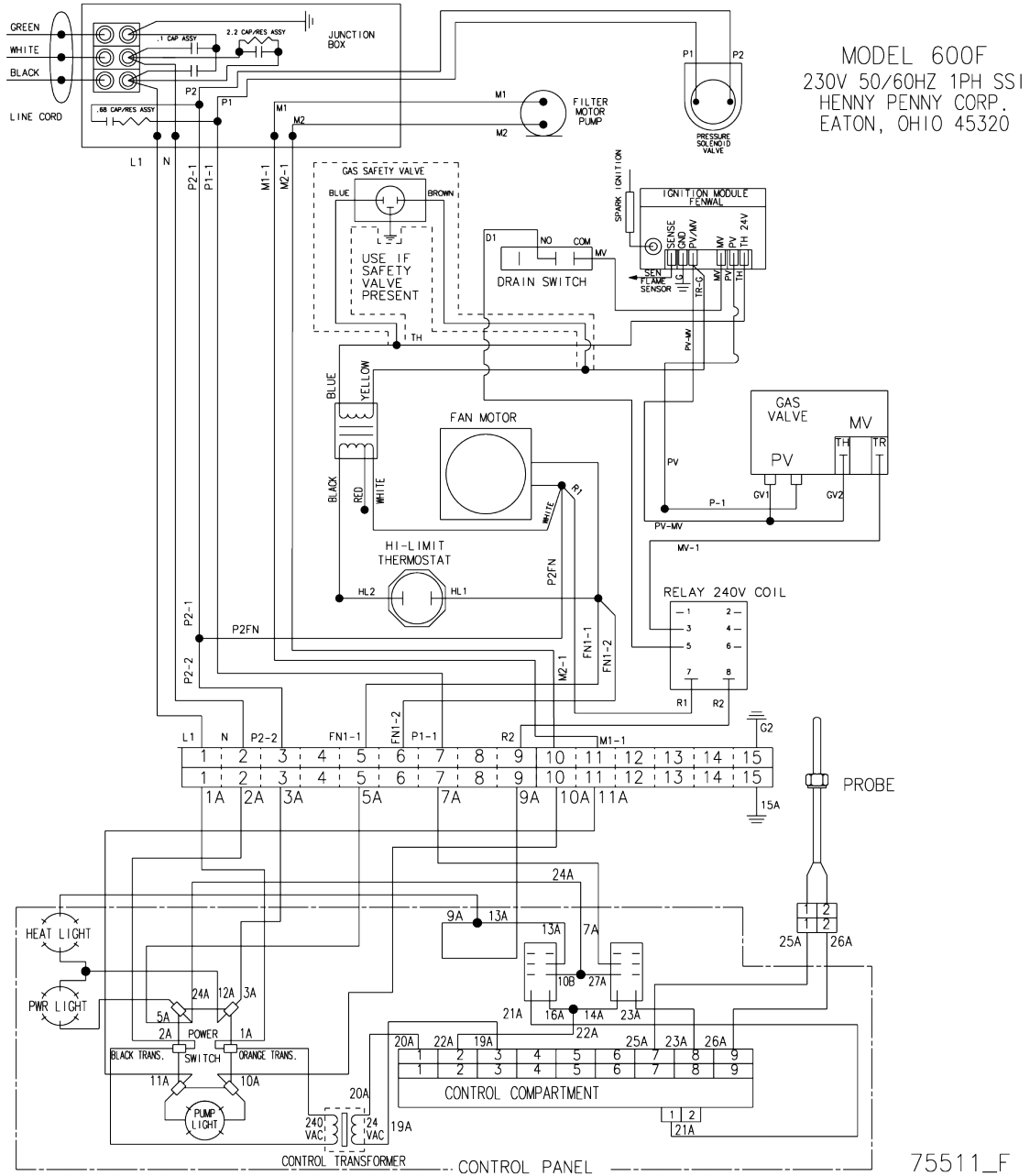

# 7.27 600 EF, 120v, 50/60Hz, 1P (23457F) (After AN0703021 use 75510)

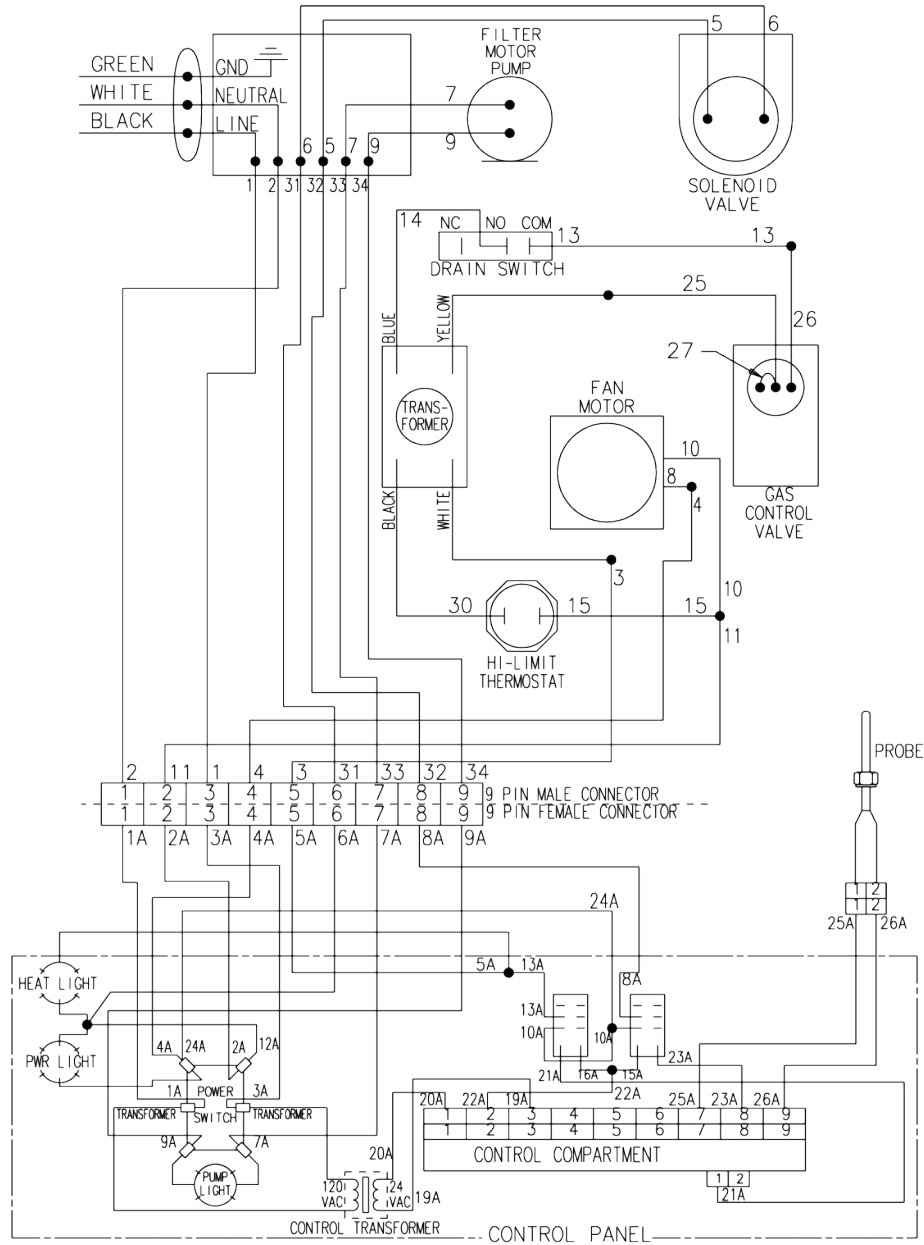

MODEL 600F  
 120V 50/60Hz 1PH  
 HENNY PENNY CORP., EATON, OHIO 45320

23457

## 7.28 600 SC GF, 120v, 60Hz, 1P, Dual Thermostat (17353F)

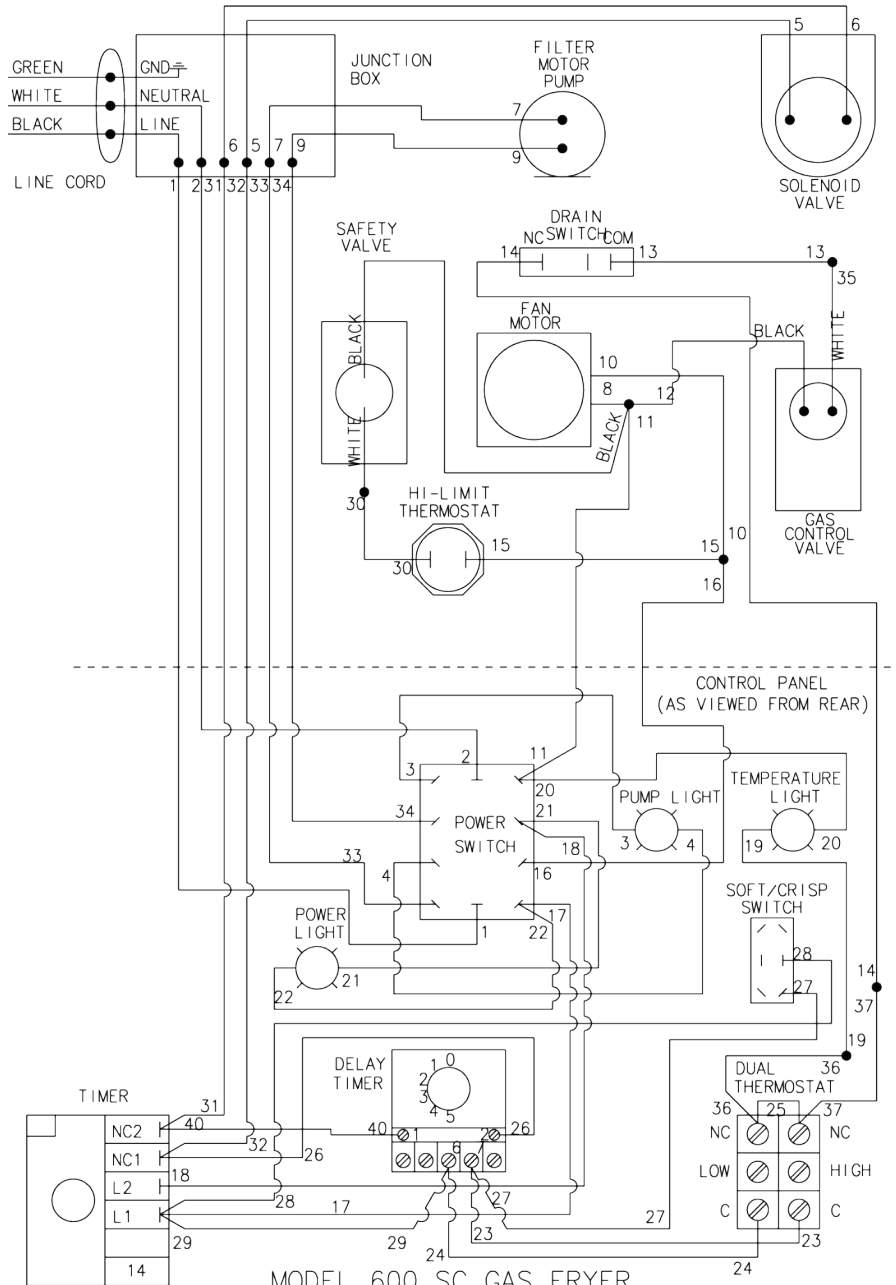

MODEL 600 SC GAS FRYER  
 120 VOLT 60 HZ 1 PHASE DUAL THERMOSTAT  
 STANDARD IGNITION VARIABLE TEMPERATURE

17353

# 7.29 600 SMS EF, 100-240v, 50/60Hz, 1P, SMS, SSI (75190D)

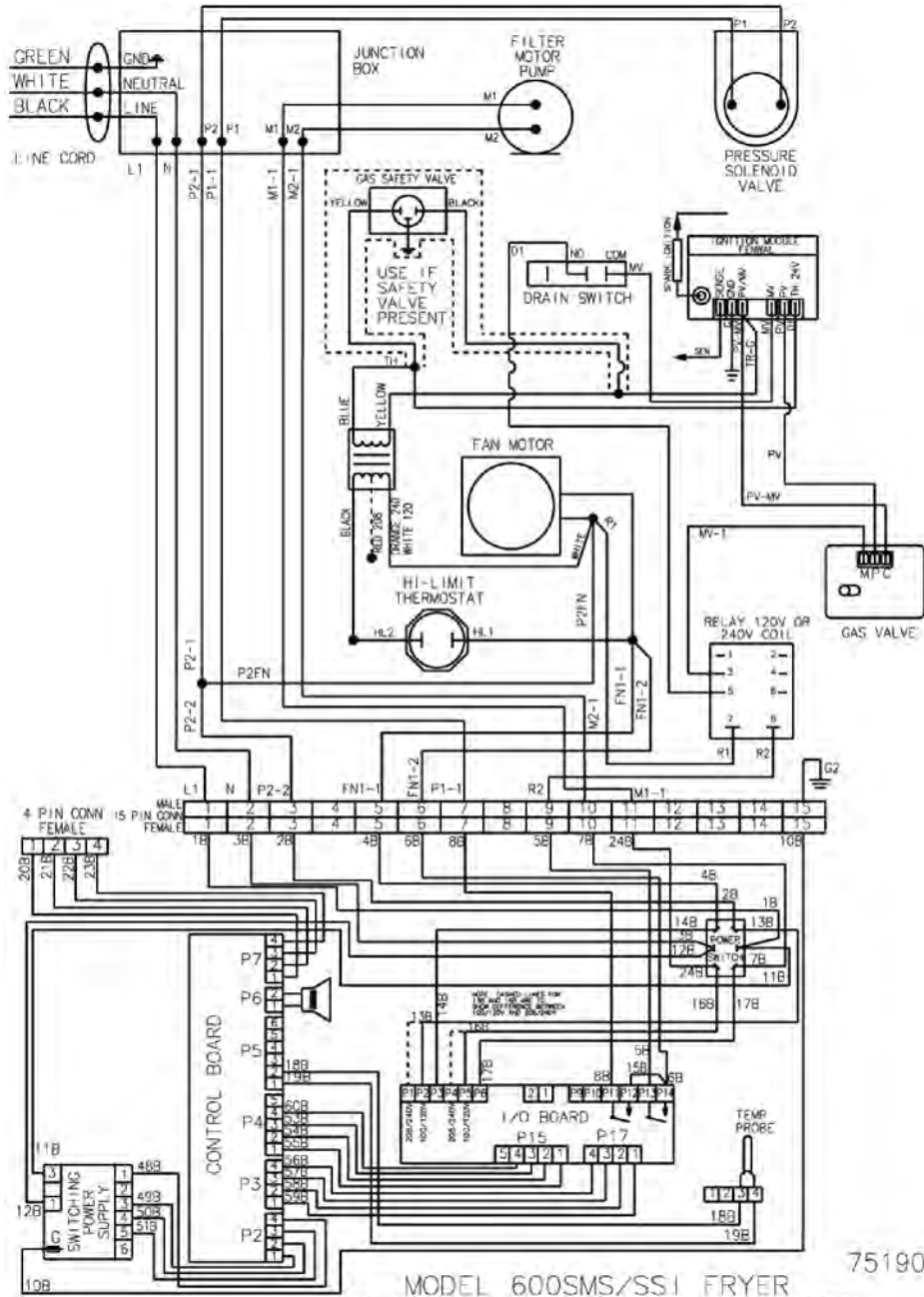

MODEL 600SMS/SSI FRYER  
100-240V 50/60HZ 1PH SMS/SSI CONTROL  
HENNY PENNY CORP., EATON, OHIO 45320

# 7.30 600 SMS EF, 230v, 50Hz, 1P, SMS, SSI (75512B) (AN0703021-711029-Shaw)

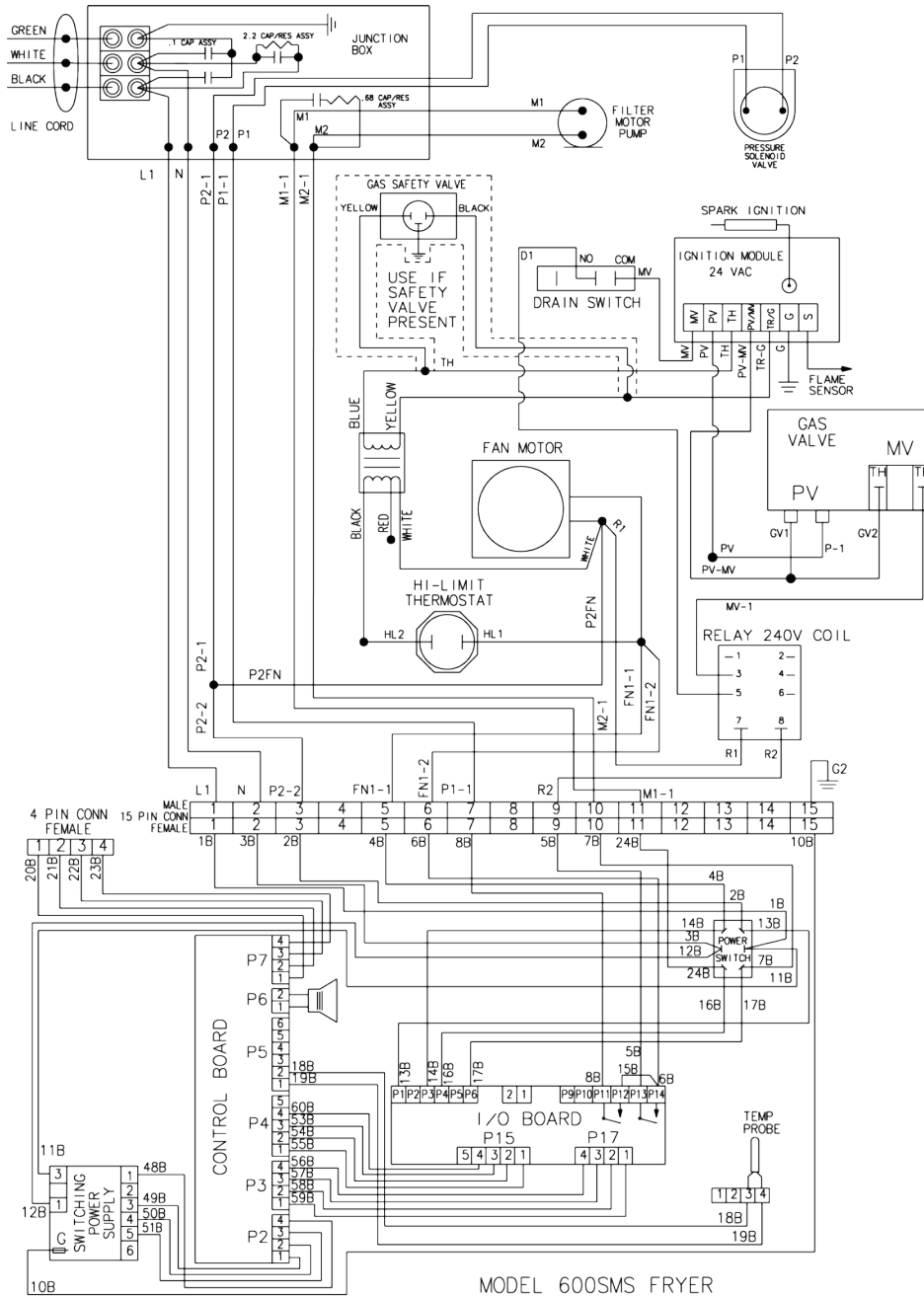

MODEL 600SMS FRYER  
 230V 50HZ 1PH SMS SSI CONTROL  
 HENNY PENNY CORP., EATON, OHIO 45320 75512





# Chapter 8 Annual Inspection

## 8.1 Henny Penny Start-Up Provider Information

Company:	Company Phone:
Address:	City:
State / Province:	Postal Code:
Country:	Store E-mail:

## 8.2 Store Information

Store ID Number:	Store Phone:
Address:	City:
State / Province:	Postal Code:
Country:	Store E-mail:

## 8.3 Equipment Information

Model:	Serial Number:
--------	----------------

## 8.4 Signatures

<b>Trainer- I have completed all steps of the start-up and training checklist to the customer's satisfaction.</b>		
Signature:	Printed Name:	Number of Attendees / Date:
Comments:		
<b>Store Manager - I am satisfied with the start-up and training received.</b>		
Signature:	Printed Name:	Date:
Comments:		

## 8.5 Checklist

Use the following checklist to rate the fryers operation.

Red Flag / Op. No.	Remove Side Panel and Rear Cover	OK	CLEAN	REPLACE
1	Inspect vat (frypot) for any signs of leakage.			
2	Inspect that the fryer sits level. Inspect casters and ensure fryer frame is not cracked or bent.			
<b>Rear of Fryer</b>				
3	Inspect electrical cord and plug.			
4	Inspect gas line, quick disconnect and tether (600 only).			
5	Perform a flue inspection (600 only).			
6	Disassemble condensation box and clean, seal seams w/silicone.			
7	<i>Rear of Fryer and front of the fryer</i> - Check that the condensation box drain line, dead weight tube, pressure release tubing is free and clear from clogs. Also that each is not damaged or leaking.			
<b>Inspect drain pan, filter motor and drain oil</b>				
8	Verify the drain valve handle micro-switch is in working condition.			
9	Inspect that drain pan is empty, all components present (filter screen, clips, crumb catcher, standpipe, lid) and it is assembled correctly.			
10	Test filter pump motor to ensure operation.			
11	Drain oil to drain pan. Ensure no drain obstructions.			
<b>Heat System</b>				
12	Tighten heating element spreader bars and high limit bracket (500 only).			
13	Inspect temperature probe, verify it is not bent or damaged. Check the insertion depth of the probe with a gauge – adjust if necessary.			
14	Inspect Burner Jets (600 only).			

Red Flag / Op. No.	Remove Side Panel and Rear Cover	OK	CLEAN	REPLACE
15	Inspect and clean pilot assembly. Adjust pilot if necessary (600 only).			
16	Inspect for excessive oil migration behind the control board.			
17	Following all instructions, inspect the high limit.			
<b>Pump Oil / Fill Fry Pot</b>				
18	Test filtration system when pumping oil back up – no obstructions, leaks or excessively slow pumping.			
19	Check amp draw of heating elements are consistent and when added up, match the amp draw listed on the data plate (500 only).			
20	Check that manifold pressure matches the data plate and gas type of the fryer (600 only).			
<b>Pressure System (front of fryer)</b>				
21	Inspect deadweight including orifice, O-ring, cap, and weight) ensure they are in good working condition.			
22	Following all instructions, perform lid latch, catch and latch spring inspection.			
23	Clean and lubricate safety pin, thrust ball, locking collar and spindle.			
24	Lubricate cross arm retaining pin.			
25	Inspect the lid cross arm.			
26	Inspect the lid gasket and reverse if wear is acceptable.			
27	Perform a limit stop adjustment.			
28	Clean safety relief valve.			
29	Remove solenoid valve and clean and reassemble.			
30	Verify the existing pressure gauge rests at zero and is free and clear			

Red Flag / Op. No.	Remove Side Panel and Rear Cover	OK	CLEAN	REPLACE
	from obstructions. (verify during pressure test).			
<b>Pressure Test</b>				
31	Following all instructions, pressure test with at least 2-head OR and verify lid locks at pressures greater than 2 psi and then unlocks only when pressure drops below 2 psi.			
	Verify in this test if pressure is regulating in the green zone. Verify that all pressure releases prior to the timer reaching 0:00. This will help to identify if there is still any pressure release and deadweight tubing obstructions.			
<b>During Pressure Test</b>				
32	Verify pressure gauge is functioning in a similar range as the calibrated test fixture.			
33	Inspect the oil return valve for leaks while under pressure. Verify there is no oil leaking back through the oil return plumbing to the drain pan while under pressure.			
34	Inspect the drain valve for leaks while under pressure.			
<b>General Fryer</b>				
35	Verify all labels are in place and legible on fryer.			
What are the tools required prior to doing this job?				
	<ul style="list-style-type: none"> <li>• Temperature probe depth gauges</li> <li>• 4-HD latch gauge</li> <li>• Pipe snake</li> <li>• Manometer</li> <li>• Amp Clamp</li> <li>• Imperial size Socket Set</li> <li>• Imperial size set of hex key wrenches</li> </ul>			

Red Flag / Op. No.	Remove Side Panel and Rear Cover	OK	CLEAN	REPLACE
<ul style="list-style-type: none"> <li>• Full range pliers set from needle nose to 12" large slip joint</li> <li>• Phillips and flat blade screwdriver set</li> <li>• Pipe wrenches 8 – 12"</li> <li>• Wire stripping tool</li> <li>• Wire cutter</li> <li>• Crimping tool</li> <li>• Adjustable wrench set 8 - 12"</li> <li>• Open end wrench set (imperial sizes)</li> </ul>				
What parts should I take with me prior to doing this job?				
<ul style="list-style-type: none"> <li>• Safety relief valve (One per fryer)</li> <li>• Latch spring</li> <li>• Latch</li> <li>• Pressure gauge</li> <li>• Lid gasket</li> <li>• Solenoid rebuild kit</li> <li>• Temperature probe</li> <li>• Spindle lube</li> <li>• Pipe thread sealant</li> <li>• Towels</li> <li>• Steel and Teflon sleeve fittings</li> <li>• Dead weight cap O-ring</li> <li>• Pilot assembly</li> <li>• Flame sensor</li> <li>• Power cord for 600</li> <li>• Plumbing elbows</li> <li>• High limit</li> <li>• Drain switch</li> <li>• Splice connectors</li> </ul>				

## 8.6 Inspect the Fry Pot



**WARNING** To avoid fire, if oil accumulation can be seen from a weld, take the fryer out of service until the fry pot is replaced.

If oil accumulation can be seen from a weld, take the fryer out of service until the fry pot is replaced. Contact Henny Penny with any questions regarding fry pot warranty.

1) Do the following:

- PFG-600: Remove the heat shield plate above the burner to gain better visibility inside the burner box.
- PFE-500: Remove side panels of fryer.

2) Do the following:

- PFG-600: Use a flashlight and inspection mirror to inspect the welds (A and B) of the fry pot and drain stem weld.
- PFE-500: Use a flashlight to inspect the corner welds, drain stem and the pot to countertop welds.

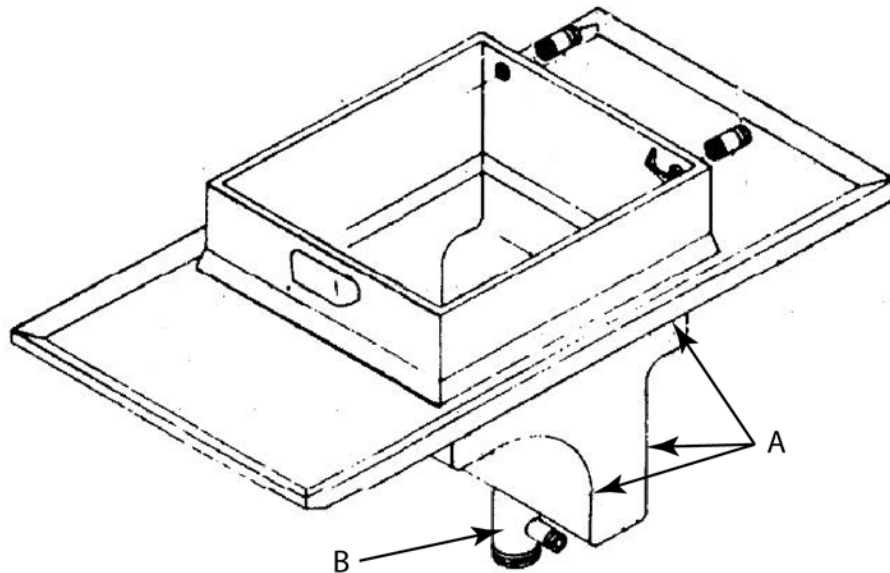

Figure 8-1 PFG 600 Weld Locations

## 8.7 Inspect the Casters and Frame



### WARNING

A cracked frame creates a tipping risk. If cracked frame is found, immediate attention is needed to repair the frame by having it professionally repaired by a welder, or having the fryer replaced.

To inspect the casters and frame do the following:

- Inspect casters and the tube steel frame by removing side panels and using a flashlight to look for cracking or bent frame (Figure 1).
- Inspect that the fryer sits level, casters are mechanically sound to hold the weight of the fryer and the tube steel frame is not cracked or bent.
- If the fryer is sitting out of level, inspect the condition of the floor. Have any missing or cracked tiles replaced.
- If there is a slope due to a floor drain, the fryer may need to be repositioned so the caster is not near this slope.

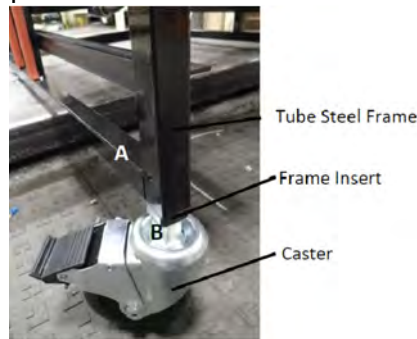

## 8.8 Inspect the Power Cord



### DANGER

**Fire Risk and Electrical Shock Possible.** If any of these conditions are found, take the fryer out of service until a new power cord or plug can be installed. Always adhere to local electrical code upon installation of the power cord.

Replace any power cord with torn or damaged sheathing, exposed wire or fraying. Replace the plug if there are any signs of damage, cracking, loose wires, burnt connections.

- Check the data plate mounted just above the lid, on the left side of the back shroud, to determine the correct power supply.
- Ensure the appliance is equipped with an external circuit breaker which will disconnect all ungrounded (unearthed) conductors. The main power switch on this appliance does not disconnect all line conductors.

## 8.9 Inspect the Gas Hose and Connection



### DANGER

If any of these conditions are found, take the fryer out of service until a new gas connection (hose, fitting, quick disconnect) can be installed. Always adhere to local code upon installation of the gas connection.

Replace any gas connection that has a damaged hose, torn or damaged sheathing, or damaged fittings or quick disconnects that no longer function properly. When replacing fittings and quick disconnects using the appropriate pipe thread sealant conforming to local code.

- Check the data plate on the right side panel of the cabinet to determine the proper gas supply requirements.
- Check the gas supply; the minimum supply for natural gas is 7 inches water column (1.74 kPa), and 10 inches water column (2.49 kPa) for propane.
- Check and ensure that a separate disconnect switch with proper capacity fuses or breakers is installed between the fryer and the power source. It should be an insulated copper conductor rated for 600 volts and 90°C. For runs longer than 50 feet (15.24 m), use the next larger wire size.
- The fryer must be located with provision for venting into adequate exhaust hood or ventilation system. This is essential to permit efficient removal of the flue gases and frying odors.
- Ensure one of the following provisions for cleaning and servicing are installed.
  - A manual gas shutoff valve and disconnect union.
  - A heavy-duty (min. 3/4 inch) design A.G.A. certified connector which complies with standard connectors for moveable gas appliances; ANSI Z21.69 or CAN/CSA 6.16.
  - A quick-disconnect coupling which complies with the Standard for Quick-Disconnect Devices for use with Gas Fuel, ANSI Z21.41 or CAN 1-6.9.
- Also, adequate means must be provided to limit the movement of the fryer without depending on the connector and any quick-disconnect device or its associated piping to limit the fryer movement, such as a cable restraint. The cable restraint limits the distance the fryer can be pulled from the wall.

**NOTE:** Refer to SafeandComp for further details.

## 8.10 Inspect the Flue

Ensure the transition from the flue to the fire box is clean with no holes from corrosion.

- 1) Remove the left and right side panels from the fryer.
- 2) Remove the rear cover.

- 3) Remove the four screws holding the flue to the firebox. One on each side of the fryer. Two underneath the flue.

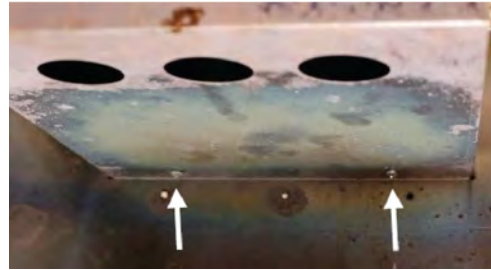

- 4) Inspect the flue and transition assembly. Clean out any debris or obstruction found in the flue assembly and inspect the integrity of the transition. If excessive corrosion causing holes to form in the transition are found, replace the flue.



## 8.11 Inspect the Condensation Box

Clean the condensation box and drain lines, removing all debris. Use a flexible wire brush to remove debris from the condensation drain line.

- 1) Remove the fryer's rear cover.
- 2) Disconnect the deadweight tube (A).
- 3) Disconnect the condensation drain line (C).
- 4) Disconnect the plumbing from the pressure solenoid (B).
- 5) Remove the condensation box mounting screws.
- 6) Cut the silicone, which seals the rear cover.
- 7) Remove the six screws fastening the interior of the box to the exterior (D).
- 8) Remove any debris from the inside of the condensation box and clean.
- 9) Remove any debris in the condensation drain line (not shown) and in the condensation drain outlet.
- 10) Slide assembly back together and seal with silicone.
- 11) Reassemble in reverse order.

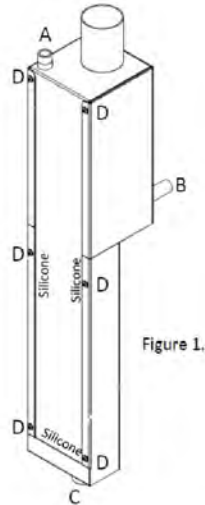

Figure 1.

A	Deadweight Tube
B	From Solenoid
C	Condensation Drain Outlet
D	Screws x6

## 8.12 Inspect the Solenoid and Deadweight Plumbing

Inspect that the plumbing from the dead weight valve and the pressure solenoid are clean, and free from debris.

- During the lid locking safety inspection if pressure exceeded 14 psi, this would indicate blockage in either the dead weight assembly or in the dead weight plumbing.
- If pressure were slow to release at the end of the lid locking safety inspection, this would indicate that either the solenoid valve needs to be cleaned or there is an obstruction in the pressure solenoid plumbing.

### 8.12.1 Clean the Dead Weight Plumbing

- 1) Remove rear cover of fryer.
- 2) Disconnect deadweight tube from dead weight hose (Figure 1).
- 3) Disconnect the dead weight tube from the dead weight assembly by loosening the compression nut at the rear of the dead weight assembly.
- 4) Clean the dead weight tube.
- 5) Clean the dead weight valve using a small pipe snake.
- 6) Clean from the outlet in the fry pot to the deadweight valve (Figure 2).
- 7) Reassemble in reverse order.



Figure 1.

A	Deadweight Tube
B	Deadweight Hose

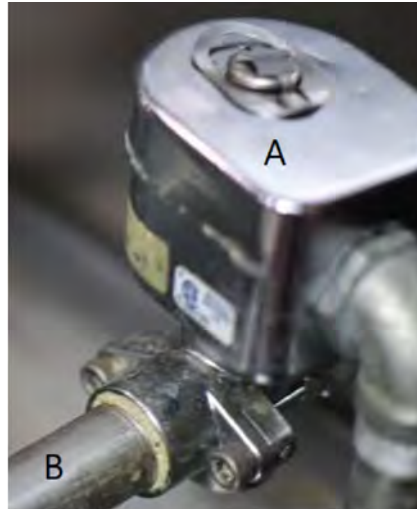

Figure 2.

A	Deadweight Assembly
B	Outlet from fry pot to deadweight

### 8.12.2 Clean the Solenoid Plumbing

- 1) Inspect and clean the plumbing from the outlet in the fry pot to the pressure solenoid.
- 2) Clean from the solenoid to the condensation box, see instructions for removal and cleaning of the condensation box.



A	Solenoid Assembly
B	Outlet from fry pot to solenoid

### 8.13 Inspect the Drain Switch



#### WARNING

To avoid electrical shock or property damage, move the power switch to off and disconnect main circuit breaker, or unplug cord at wall receptacle.

All fryer models have a drain microswitch in line with the gas control valve and thermostat. When the drain valve is opened to drain the shortening, this causes drain switch to open, shutting off electrical power to the heating elements.

- 1) Ensure the drain valve and switch are in the closed position, and then remove power from fryer at the wall outlet.
- 2) Check the continuity between terminal 52 on the thermostat and the wire nut between the drain switch and gas control valve. If circuit is open, the drain switch is bad and needs to be replaced.

### 8.14 Test the Filtration System



#### WARNING

Close the lid, using it as a shield during the initial surge of oil filling the vat to prevent splashing, preventing personal injury.

Run a filtration to test the system and ensure:

- Plumbing and pump is free of clogs and is working properly.
- Air is not leaking in to the system.
- Test for leaks in the system.

- 1) With the oil hot, turn the main power switch to the OFF position.
- 2) Open the drain valve and let the oil drain in to the drain pan.
- 3) Open the filter valve, and then turn the main power switch to the pump position.
- 4) Listen to the pump. If the pump is too quiet, this can indicate air in the system. If the pump is too loud, this indicates a clog in the system.
- 5) Close the filter and drain valve. Ensure oil fills the vat.
- 6) Empty the condensation pan.

## 8.15 Inspect the Drain Pan

**! WARNING** Use Personal Protective Equipment (PPE) such as gloves, face shield, etc. to prevent burns from hot oil.

- 1) Turn the main power switch to the OFF position.
- 2) Open the drain valve and let the oil drain in to the drain pan.
- 3) Disconnect the filter union, remove the drain pan and discard the oil.
- 4) Disassemble the drain pan and ensure all the components are present and in working condition.

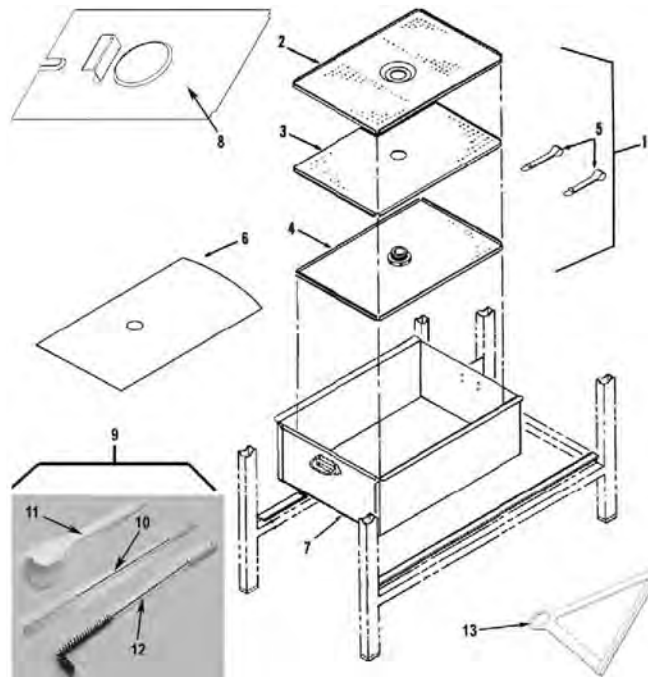

- 5) Reassemble the pan and reinstall under the fryer.

## 8.16 Inspect the High Limit

Ensure the high limit is mounted properly and functioning as intended.

- 1) Visually inspect the high limit probe bulb and capillary tube mounted inside the fry pot. Ensure the bulb is not dented and the capillary tube is not severed. If the capillary tube or bulb is damaged, take the fryer out of service until it is replaced.

PFE-500

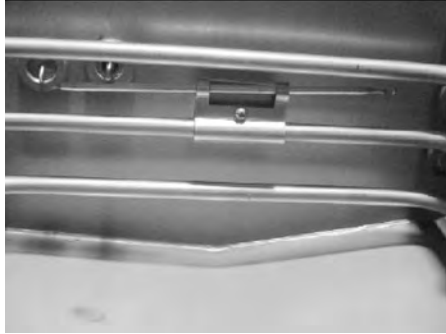

PFG-600

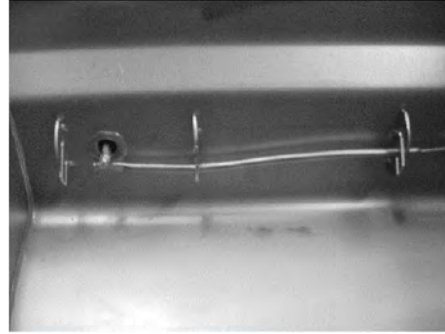

- 2) Press the red reset button on the high limit several times. If this button clicks each time it is pressed, take the fryer out of service until the high limit can be replaced and make sure it gets wired into the circuit upon replacement. Also, note this on the inspection form.
- 3) Remove power from fryer at the wall outlet.

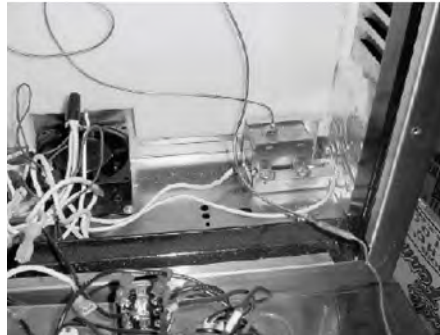

- 4) Lower the controls, and then remove the two mounting screws that secure the high limit body to the fryer.
- 5) Remove the high limit and make sure the high limit wiring is properly connected to the high limit.

Inspect that each high limit wire is attached to separate terminals on the high limit. If both wires are attached to the same terminal, or if one or both of the terminals are missing wires, this indicates that the high limit has been bypassed in the circuit. If bypassing is found, take the fryer out of service until the wiring is corrected and high limit replaced if defective.

## 8.17 Inspect the Temperature Probe

Inspect the temperature probe for damage. If the probe is damaged or broken, replace it with the correct part. A damaged probe can lead to inconsistent cooking issues and intermittent temperature fluctuation.

**NOTE:** There are two probes for KFC units depending on which control board is installed in the fryer: Fastron or SMS. Fastron probes are not interchangeable with SMS probes.

<b>Inspect the Temperature Probe</b>	
	<ol style="list-style-type: none"> <li>1. Drain and discard oil from vat.</li> <li>2. Visually inspect the temperature probe. <ul style="list-style-type: none"> <li>• The probe should be clean and straight. If not, replace the probe.</li> <li>• If the probe is not bent or damaged continue with the adjustment inspection.</li> </ul> </li> </ol>
<b>Adjustment Inspection</b>	
<p><small>NOTE:</small></p> <ol style="list-style-type: none"> <li>1.) LOCATE TEMPERATURE PROBE THRU POT WALL.</li> <li>2.) PLACE GAUGE AGAINST POT WALL AS SHOWN.</li> <li>3.) PUSH TEMPERATURE PROBE THRU UNTIL IT MAKES CONTACT WITH GAUGE.</li> <li>4.) TIGHTEN TEMPERATURE PROBE IN PLACE.</li> </ol>	<p><b>NOTE:</b> Fastron probes are set to a fixed depth into the vat (frypot). Use a probe gauge or ruler to set the SMS probe to a depth of:</p> <ul style="list-style-type: none"> <li>• 500 (Electric) 5/8"</li> <li>• 600 (Gas) 7/8"</li> </ul> <p>Adjust the depth if needed by loosening the compression fitting on the probe and sliding the probe either in or out to the correct depth. Then tighten the probe's compression fitting.</p>

## 8.18 Inspect the Burner

### 8.18.1 Clean the Burner Jets

Remove breading, dust and obstructions from burner jets. Partially obstructed burners lower the BTU / KW output of the fryer which can affect cook times, product quality and doneness.

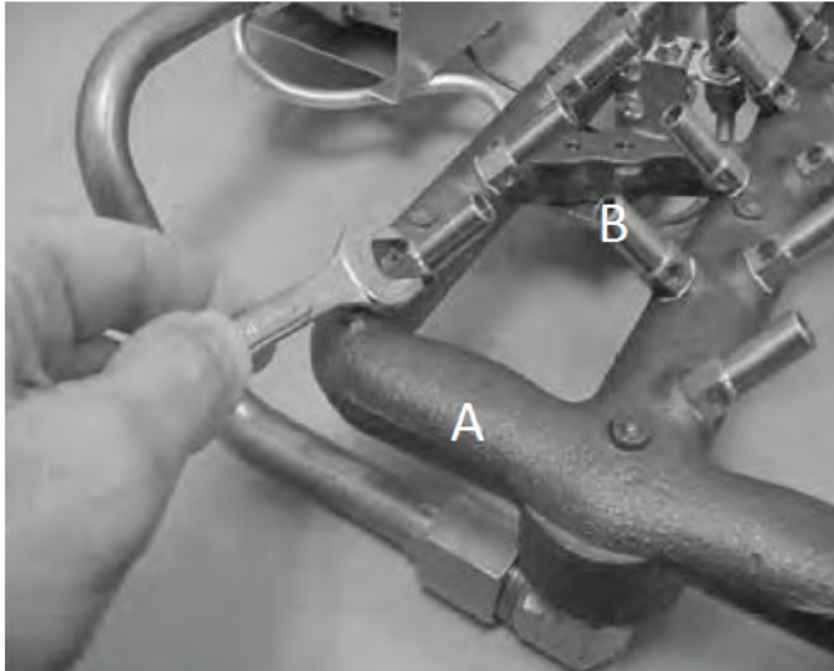

A	Burner Casting
B	Burner Jet (typical)

- 1) Check and adjust the fryer's manifold gas pressure.
- 2) Visually inspect the burner for any signs of clogged or obstructed burner jets.  
**NOTE:** The flame above each burner jet should be a consistent blue color and each jet should be about the same size. A burner jet without a flame or where the flame is yellow or small would be a sign of a clogged or partially clogged jet.
- 3) If there are any burner jets that are partially obstructed, turn off the gas supply to the fryer at the shut off valve, and then remove power from fryer at the wall outlet.
- 4) Remove the burner assembly from the fryer following the removal procedure in the technical manual.
- 5) Ensure the burner orifices are clean and free from debris. If debris exists, gently remove it by hand with an orifice cleaning tool.
- 6) Reinstall burners in reverse order.
- 7) Test gas connections for leaks.

### 8.18.2 Clean the Pilot Assembly

Remove braiding, dust and debris from the pilot assembly to prevent flame sense issues due to plugged pilot orifices, or a plugged pilot venturi.



- 1) Turn off the gas supply to the fryer at the shut off valve, and then remove power from fryer at the wall outlet.
- 2) Remove the pilot gas line and pilot mounting screws.
- 3) Remove any debris or carbon build up from the spark ignitor and flame sensor (thermocouple on older units).
- 4) Remove braiding, dust and debris from the venturi and pilot orifice. If the orifice is plugged, either remove with a very small wire or orifice cleaning tool or replace the pilot orifice.
- 5) Reinstall in reverse order and retest.

## 8.19 Inspect for Oil Leaks



**WARNING** Use Personal Protective Equipment (PPE) such as gloves, face shield, etc. to prevent burns from hot oil.

### 8.19.1 Plumbing Leaks in Filtration

- 1) Remove the right side panel from the fryer.
- 2) Use a flashlight to inspect the fittings of the filtration plumbing and between the filter pump and motor for oil leaks
- 3) Drain about half the vat of oil to the drain pan.
- 4) Turn the power switch to the pump position to pump the oil back up to the fry pot.
- 5) While the oil is pumping, use a flashlight to inspect for oil leaks.
- 6) If leaks are detected with plumbing, disassemble, clean, and reassemble the fittings using pipe thread sealant on threaded fittings, or replacing any worn sleeve fittings on compression fittings.
- 7) If leaks are detected between the filter pump motor and the filter pump, replace the seal kit.

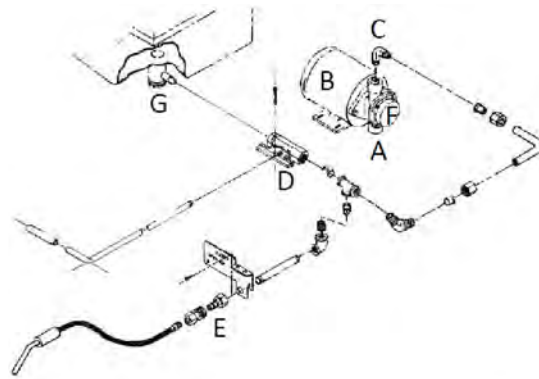

A	Suction Side of Pump
B	Filter Pump
C	Pressure Side of Pump
D	Return Valve
E	Optional Filter Rinse Hose Connection
F	Pump
G	Drain Valve

### 8.19.2 Plumbing Leaks During Cooking

- 1) Before test, disconnect the dairy unit where the drain pan connects to the oil return line.
- 2) While the fryer is pressurized to 12 psi, inspect both the drain valve and the dairy union connection for leakage:
  - If there is significant leaking, more that just a drop every now and then detected from the drain valve, then replace it.
  - If there is significant leaking, more that just a drop every now and then detected from the oil return line, then replace it.

### 8.20 Test Pressure Regulator



**DANGER**

Ensure the gas pressure is set correctly. Incorrectly set gas pressure can result in oil overflowing the vat, serious burns, personal injury, fire, and/or property damage.

The gas pressure regulator on the gas control valve is factory set as follows:

- Natural: 3.5 inches water column (0.87 kPa)
- Propane: 10.0 inches water column (2.49 kPa)
  - 1) Turn off the gas supply to the fryer at the shut off valve, and then remove power from fryer at the wall outlet.
  - 2) Locate the pressure tap hole or fitting on the side of the gas valve. If necessary, remove the pipe plug from the valve fitting.



- 3) Screw a pressure tap fitting into the valve or the fitting on the side of the valve.



- 4) Place one end of a vacuum hose on the pressure tap fitting and the other end on the manometer.
- 5) Turn on the gas supply to the fryer at the shut off valve and return power to the fryer from the wall outlet.
- 6) Turn the fryer on and allow the fryer to reach full burn.
- 7) The pressure reading on the manometer should be:
  - Natural: 3.5 inches water column (0.87 kPa).
  - Propane: 10.0 inches water column (2.49 kPa).
- 8) Turn the fryer off, turn off the gas supply to the fryer at the shut off valve, and then remove power from fryer at the wall outlet.
- 9) Remove the pressure tap fitting and place the pipe plug back in to the valve or the fitting on the valve.
- 10) Return the fryer to normal operation.

## 8.21 Inspect Deadweight

The deadweight assembly allows the fryer to obtain and then maintain proper cooking pressure. If faulty or not properly maintained by the operator the fryer cannot operate within designed specifications. Safety issues and poor product quality can result.

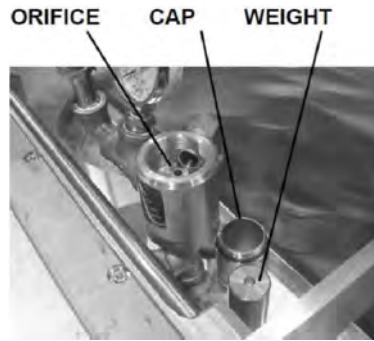

- 1) Remove the deadweight cap.
- 2) Inspect and replace the cap's O-ring if necessary.
- 3) Ensure the deadweight is present and in working condition.
- 4) Inspect the orifice.
- 5) Clean and replace components as necessary.

## 8.22 Inspect Latch, Catch and Spring

To make sure the latch, catch and latch spring are properly installed and are within tolerances for safe operation. Refer to the [Annual Inspection Video on Vimeo](#).

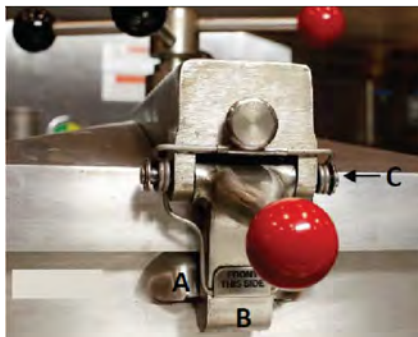

### Objective

To make sure the latch, catch and latch spring are properly installed and are within tolerances for safe operation.

- A. Catch
- B. Latch
- C. Latch Spring



### Catch Inspection

1. Slide gauge #162410 along the entire width of the pot catch.



2. If this gauge does not slide over the catch, or the lip of the catch does not match the profile of the gauge as shown, the catch is out of tolerance. Take the pressure fryer out of service until the fry pot has been replaced.



#### Latch Inspection

1. Separate the lid and the cross arm. Notice the gap in the middle of the latch.





- Slide the “GO” side of the gauge over the entire width of the latch. The latch should fit in the groove, except for the gap in the middle.

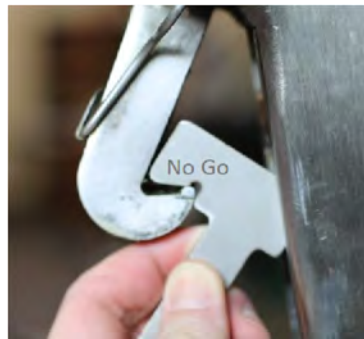

- Slide the “NO GO” side of the gauge over the entire width of the latch. If the lip of the latch inserts into the cut out in the gauge, this latch fails inspection and needs to be replaced.

### Latch Spring Inspection

Make sure the latch spring and all of its components (latch spring, latch pin, spacers, and C-clip retainer) are not broken, not missing and installed correctly. If any components are broken, damaged, missing or installed incorrectly, this fryer would need to be taken out of service until which time the components can be replaced and installed correctly. The latch spring is installed correctly if the label “FRONT THIS SIDE” is mounted to the front of the latch.

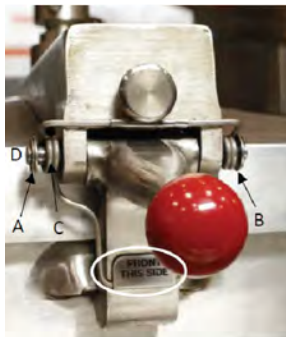

- A. C-Clip Retainer
- B. Spacers
- C. Latch Spring
- D. Latch Pin

## 8.23 Inspect Cross Arm Component

Refer to the [Annual Inspection Video on Vimeo](#).

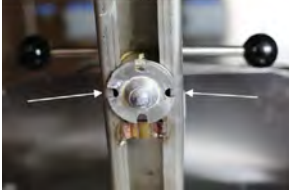

1. Separate the lid and cross arm.
2. Inspect the cross arm. Cracks on the bottom surface of the cross arm are acceptable, but anything rounding the corners, coming up the sides, or found on top would fail inspection.

If any cracks are found in the top or sides of the cross arm, the fryer would be taken out of service until the lid assembly is replaced.

3. Inspect to make sure all of the spindle components are in place: acme nut, idle nut, thrust ball, locking collar. Inspect the gap between the acme nut and the idle nut. These two components should be within 1/16" of each other. If any of these components are excessively worn, damaged or missing, this step of the inspection would fail. The fryer would be taken out of service until the damaged or missing component is replaced.

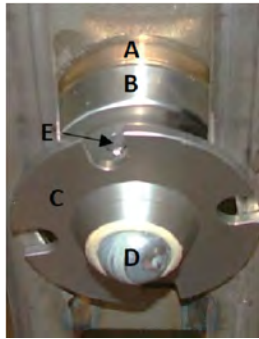

**WARNING:** This pin should be staked on each side to prevent it from shifting. If this pin is not properly staked, severe burns could result.

4. Inspect the locking collar pin. If the pin has shifted, is missing, broken, take the fryer out of service until a new pin can be installed and properly staked.

- A. Acme Nut
- B. Idle Nut
- C. Locking Collar
- D. Thrust Ball
- E. Locking Collar Pin

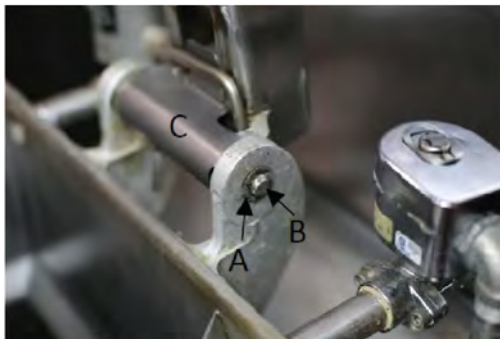

5. Inspect the hinge pin to ensure it is not missing, damaged or broken. Make sure that the retaining clips are securely in place on each side of the pin. If any of these situations are true, take the fryer out of service until the components are replaced.

- A. Retaining Clip
- B. Hinge Pin
- C. Spring Cover

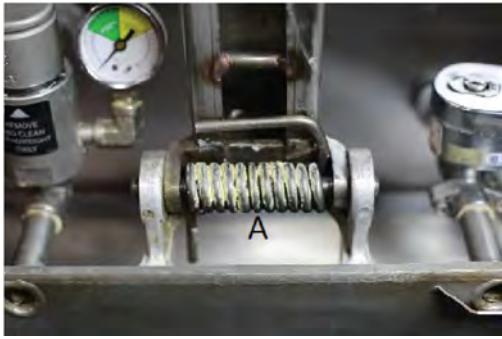

6. If the hinge spring is broken. It will not fail the inspection but the spring would need to be replaced ASAP.

A. Retaining Clip

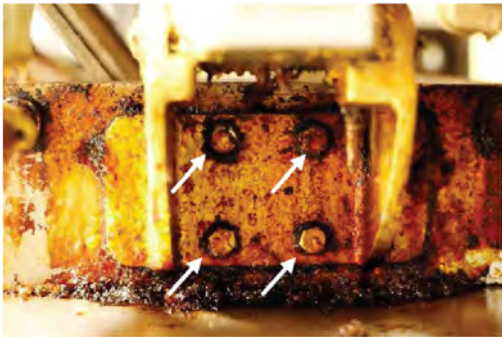

7. Ensure four bolts are installed in the hinge plate at the rear of the fry pot. Check to make sure these bolts are snug. If any bolts are missing, take the fryer out of service until they can be replaced.

## 8.24 Lubricate Cross Arm Components

Follow these steps to reduce wear on the spindle, thrust ball, ball seat, hinge spring, and locking pin. Refer to the [Annual Inspection Video on Vimeo](#).

**Objective:** Reduce wear on the spindle, thrust ball, ball seat, hinge spring, and locking pin.

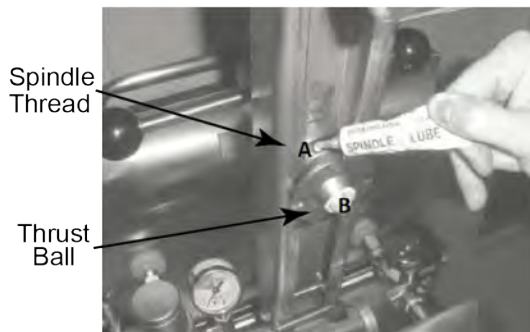

### Latch Inspection

1. Separate the lid and the cross arm.  
Notice the gap in the middle of the latch.

2. Use spindle lube (#12124) to lubricate the threads of the spindle and the thrust ball.

A. Spindle Threads

B. Thrust Ball

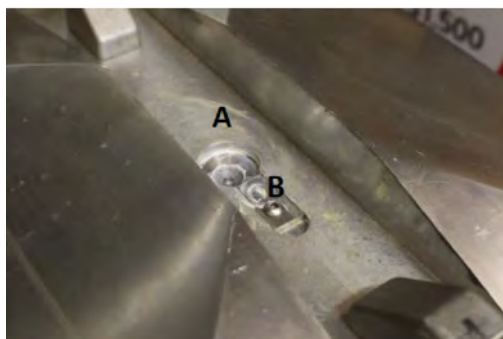

3. Lubricate the top of the locking pin, and the ball seat.

A. Ball Seat

B. Locking Pin



4. Lubricate the coils of the hinge spring by removing and re-installing the spring cover.

5. Engage the lid back to the cross arm.

A. Spring and Spring Cover

## 8.25 Pressure Regulation and Exhaust System

### 8.25.1 Clean the Lid Liner

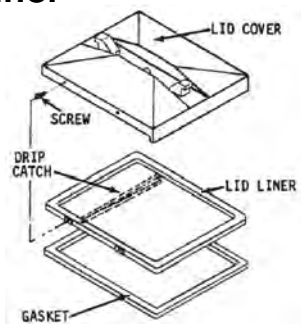

1) Remove the four lid liner screws.

2) Use a thin blade screwdriver to pry lid liner from the cover.

- 3) Clean the liner and the inside of the cover. Replace the liner and screws.

### 8.25.2 Reverse the Lid Gasket

Because of heat expansion and the pressure used for the cooking process, the gasket is constantly under extreme stress. Reversing the lid gasket on a quarterly basis will help to assure that the fryer will not lose pressure through leakage. Reverse the gasket by doing the following:



1. There are two lid liner screws on either side of the lid cover. Back these four screws out about 1/2 inch.



2. Open the lid and using a thin blade screwdriver, pry out the gasket at the corners. Remove the gasket.
3. Clean the gasket and gasket seat with hot water and cleaning detergent. Rinse with clean hot water.
4. Install the gasket with the good side (reverse side) facing out.



5. Begin the installation by installing the four corners of the lid gasket. Continue by pressing the gasket in to the channel from the corners outward.
6. Tighten the four screws.

### 8.25.3 Adjust the Lid Limit Stop

The lid limit stop, with proper adjustment, prevents unnecessary overtightening of the spindle extending the life of the lid gasket.



1. Loosen the Allen set screws on the bottom of the collar of the limit stop assembly.
2. Turn the inner collar of the limit stop clockwise as far as possible.  
**Best Practice:** Find the small hole in the inner collar and use a small Allen wrench or Phillips head to help in turning the collar.
3. Close the lid and turn the spindle until the lid gasket meets the top of the vat (fry pot) rim.
4. From this position, turn the spindle at least 3/4 of a turn, but not more than one full turn.
5. After rotating the spindle to this point, slightly extend the spindle past this position. The spindle should be at the seven o'clock position.

**NOTICE:** The seven o'clock position allows slight additional turning of the spindle to relieve any side pressure that could hold the locking pin in the locking collar after all pressure has been released from the vat (fry pot).

6. If necessary, remove the knobs and change their position in order to align the red knob with the red knob on the lid cover lid latch. When in the normal operating position, both red knobs should be aligned.
7. Adjust the limit stop by turning it counterclockwise until it stops against the bottom hub of the spindle.
8. Tighten Allen set screws.
9. Test the lid seal. If the lid cover fails to seal properly, steam will escape around the gasket during the frying operation. Readjust the limit stop by repeating steps 1 through 7, but this time turn the spindle screw one full turn after the initial contact of the lid gasket against top of the vat (fry pot) rim.

#### 8.25.4 Removal and Cleaning of Safety Relief Valve



#### WARNING

Do not attempt to remove valve while fryer is operating. Severe burns or other injuries could result.



Safety Valve

The safety relief valve should be cleaned once a year.

1. Open the lid and then remove the deadweight valve cap and deadweight.
2. Use a wrench to loosen the valve from the pipe elbow, turn counterclockwise to remove.
3. Clean the inside of the pipe elbow with hot detergent.
4. Immerse the safety relief valve in a soap water solution for 24 hours. Use a 1:1 dilution rate. The valve cannot be disassembled. It is factory preset to open at 14 1/2 pounds of pressure. If it does not open or close it must be replaced.

### 8.25.5 Pressure Gauge Calibration



#### WARNING

To avoid personal injury, do not disassemble or modify this valve. Tampering with the valve will void agency approvals and the appliance warranty, and could cause serious injury.



Adjusting Screw

The pressure gauge can be recalibrated if out of adjustment.

1. Remove the rim and glass.
2. If the indicating hand shows a pressure or vacuum reading when it should point to "0", turn the calibration screw until the hand stands at the "0" position.
3. Replace the rim and glass.

### 8.25.6 Coil Check Procedure



#### WARNING

To avoid electrical shock or property damage, move the power switch to OFF and disconnect main circuit breaker, or unplug cord at wall receptacle.

1. Remove power from the fryer by unplugging from the power source.
2. Remove wires from terminals 73 and 72 and check ohms across the solenoid wires.

Volts/Phase:	Results:
- 120 volt 60 Hz	- 50 ohms
- 208-240 volt 60 Hz	- 150 ohms
- 208-240 volt 50 Hz	- 245 ohms

### 8.25.7 Locking Pin Test Procedure

Ensure the lid locking pin engages the locking collar of the spindle when the pressure in the fry pot reaches 2 psi and greater and also to ensure the lid locking pin remains engaged as pressure releases at 2 psi. Refer to the [Annual Inspection on Vimeo](#).



Figure 1

1. Remove the reducer from the test fixture (Figure 1).



Figure 2

2. Install the supplied elbow from the test fixture into the t-fitting with pipe thread sealant (Figure 2).



Figure 3

3. Remove the existing safety relief valve (Figure 3).



Figure 4

4. Install the test fixture into the safety relief valve elbow using pipe thread sealant (Figure 4).



Figure 5

5. Insert the existing pressure gauge into the elbow of the pressure test fixture (Figure 5).

7:00 Position

6. Adjust the limit stop so that the red ball reaches the 7:00 position when closing and locking down the lid (Figure 6). See [8.25.3 Adjust the Lid Limit Stop](#), page 255.
-



Figure 6

6:00 Position



Figure 7

7. Have the store bread and cook at least two head of chicken.
8. When the pressure on the calibrated test gauge reaches 2 psi, gently turn the spindle counter clockwise using two hands so the red ball lines up with the 6:00 position (Figure 7). The locking pin should engage the locking collar causing the spindle to lock in place (red ball at 6:00).

5:00 Position



Figure 8

9. If the spindle continues to turn past the 5:00 position (Figure 8), the locking pin test would fail. Take the fryer out of service until the locking pin issue is addressed or the lid replaced.
10. During the cook cycle when pressure reaches the 12 psi range. Compare the existing pressure gauge with the calibrated test gauge. The existing pressure gauge should read in a similar range. If it is not, replace the existing pressure gauge after the test.
11. If pressure during the cook cycle exceeds 14 psi, this does not fail the test as long as the locking pin engagement and disengagement steps pass. However, after the test, the deadweight and all related plumbing would need to be thoroughly cleaned or replaced.
12. When pressure exhausts and nears the 2 psi mark, using two hands, gently turn the spindle counterclockwise. If you are able to turn the spindle to the 5:00 position (Figure 8), this inspection fails. Take the fryer out of service until the lid assembly can be replaced. To pass the inspection, the spindle should remain locked at 2 psi when trying to turn counterclockwise. If the lid is locked, the spindle should remain in the 6:00 position (Figure 7).
13. If the pressure was slow to release during the cook cycle and did not reach 0 psi when the timer reached 0:00, this does not fail the inspection, however this is an indication that the pressure solenoid and/or its related plumbing may be sticking or obstructed. After the test, clean the solenoid and the related solenoid plumbing back to the steam exhaust stack.
14. Remove the test fixture.
15. If the existing safety relief valve passed the inspection, re-install it. If not, install a new valve with pipe thread sealant.







**Henny Penny Corporation**  
**P.O.Box 60**  
**Eaton, OH 45320**  
**[www.hennypenny.com](http://www.hennypenny.com)**

**Inside the U.S.:**  
**1-800-417-8405**  
**[technicalservices@hennypenny.com](mailto:technicalservices@hennypenny.com)**

**Outside the U.S.**  
**1-937-456-8405**  
**[intltechsupport@hennypenny.com](mailto:intltechsupport@hennypenny.com)**