



# OPERATOR'S M A N U A L

---

**PRESSURE FRYER (Gas)**

---

**MODEL  
PFG-691**



**HENNY PENNY**  
Engineered to Last

REGISTER WARRANTY ONLINE AT [WWW.HENNYPENNY.COM](http://WWW.HENNYPENNY.COM)



## NOTICE

This manual should be retained in a convenient location for future reference.

A wiring diagram for this appliance is located on the rear shroud cover of the control panel.

Post in a prominent location, instructions to be followed if user smells gas. This information should be obtained by consulting the local gas supplier.

Do not obstruct the flow of combustion and ventilation air. Adequate clearance must be left all around appliance for sufficient air to the combustion chamber.

The Model PFG-691 pressure fryer is equipped with a continuous pilot. But fryer cannot be operated with out electric power. Fryer will automatically return to normal operation when power is restored.

## CAUTION

*Keep appliance area free and clear from combustibles.*



**Improper installation, adjustment, alteration, service or maintenance can cause property damage, injury or death. Read the installation, operating and maintenance instructions thoroughly before installing or servicing this equipment.**



**DO NOT STORE OR USE GASOLINE OR OTHER FLAMMABLE VAPORS AND LIQUIDS IN THE VICINITY OF THIS OR ANY OTHER APPLIANCE. FIRE OR EXPLOSION COULD RESULT.**

### Technical Data for CE Marked Products

Nominal Heat Input: (Net)	Natural ( $I_{2H}$ ) = 26,4 kW (90,000 Btu/h) Natural (I2E) = 26,4 kW (90,000 Btu/h) Natural (I2S) = 23,75 kW (81,000 Btu/h) Liquid Propane ( $I_{3p}$ ) = 27,0 kW (92,000 Btu/h)
Nominal Heat Input: (Gross)	Natural ( $I_{2H}$ ) = 29,3 kW (100,000 Btu/h) Natural (I2E) = 29,3 kW (100,000 Btu/h) Natural (I2S) = 26,4 kW (90,000 Btu/h) Liquid Propane ( $I_{3p}$ ) = 29,3 kW (100,000 Btu/h)
Supply Pressure:	Natural ( $I_{2H}$ ) = 20 mbar Natural (I2E) = 20 mbar Natural (I2S) = 25 mbar Liquid Propane ( $I_{3p}$ ) = 37/50 mbar
Test Point Pressure:	Natural ( $I_{2H}$ ) = 8,7 mbar Natural (I2E) = 8,7 mbar Natural (I2S) = 8,7 mbar Liquid Propane ( $I_{3p}$ ) = 25 mbar
Injector Size:	Natural ( $I_{2H}$ ) = 2,51 mm Natural (I2E) = 2.51 mm Natural (I2S) = 2.85 mm Liquid Propane ( $I_{3p}$ ) = 1,40 mm

This appliance must be installed in accordance with the manufacturer's instructions and the regulations in force and only used in a suitable ventilated location. Read the instructions fully before installing or using the appliance.

### Datos Tecnicos Para Products CE

Consumo Calorico Nominal: (Neto)	Gas Natural ( $I_{2H}$ ) = 26,4 kW (90,000 Btu/h) Gas Natural (I2E) = 26,4 kW (90,000 Btu/h) Gas Natural (I2S) = 23,75 kW (81,000 Btu/h) Propano Licuado ( $I_{3p}$ ) = 27,0 kW (92,000 Btu/h)
Consumo Calorico Nominal: (Bruto)	Gas Natural ( $I_{2H}$ ) = 29,3 kW (100,000 Btu/h) Gas Natural (I2E) = 29,3 kW (100,000 Btu/h) Gas Natural (I2S) = 26,4 kW (90,000 Btu/h) Propano Licuado ( $I_{3p}$ ) = 29,3 kW (100,000 Btu/h)
Presion De Alimentacion:	Gas Natural ( $I_{2H}$ ) = 20 mbar Gas Natural (I2E) = 20 mbar Gas Natural (I2S) = 25 mbar Propano Licuado ( $I_{3p}$ ) = 37/50 mbar
Presion En Ez Punto De Prueba:	Gas Natural ( $I_{2H}$ ) = 8,7 mbar Gas Natural (I2E) = 8,7 mbar Gas Natural (I2S) = 8,7 mbar Propano Licuado ( $I_{3p}$ ) = 25 mbar
Diámetro Boquilla:	Gas Natural ( $I_{2H}$ ) = 2,51 mm Gas Natural (I2E) = 2.51 mm Gas Natural (I2S) = 2.85 mm Propano Licuado ( $I_{3p}$ ) = 1,40 mm

Este equipo debe instalarse únicamente en un recinto adecuadamente ventilado y conforme a las indicaciones del fabricante y a las normas vigentes. Lea completamente las instrucciones antes de instalar o usar este equipo.

# HENNY PENNY 8 HEAD GAS PRESSURE FRYER SPECIFICATIONS

Height	61" (155 cm)
Width	24" (61 cm)
Depth	41 <sup>3</sup> / <sub>4</sub> " (106 cm)
Floor Space	Approximately 7 sq. ft. (0.65 sq. m.)
Pot Capacity	8 head of chicken (24 lbs.) (10.9 kg) 130 lbs. shortening (59 kg)
Electrical	120 VAC, 1 Phase, 50/60 Hz, 10 Amp, 3 Wire Service 230 VAC, 1 Phase, 50 Hz, 3 Wire Service
Heating	Propane or Natural Gas; 100,000 btu/hr (105 MJ/hr)
Pressure	12 psi operating pressure (827 mbar) 14.5 psi safety relief pressure (999 mbar)
Shipping Weight	Approximately 935 lbs. (424 kg)

## NOTICE

A data plate, located on the back shroud behind the lid, gives the information of the type of fryer, serial number, warranty date, and other information pertaining to fryer. Also, the serial number is stamped on the outside of the frypot. See figure below.

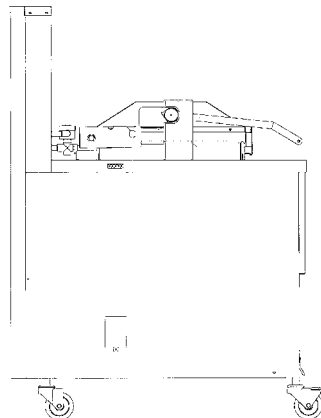

## TABLE OF CONTENTS

<b>Section</b>	<b>Page</b>
Section 1. INTRODUCTION .....	1-1
1-1. Pressure Fryer .....	1-1
1-2. Proper Care .....	1-1
1-3. Assistance .....	1-1
1-4. Safety .....	1-2
Section 2. INSTALLATION .....	2-1
2-1. Introduction .....	2-1
2-2. Unpacking Instructions .....	2-1
2-3. Selecting the Fryer Location .....	2-4
2-4. Leveling the Fryer .....	2-4
2-5. Ventilation of Fryer .....	2-5
2-6. Gas Supply .....	2-5
2-7. Gas Piping .....	2-5
2-8. Gas Pressure Regulator Setting .....	2-8
2-9. Electrical Requirements .....	2-8
2-10. Testing the Fryer .....	2-9
2-11. Gas Leak Test .....	2-9
Section 3. OPERATING INSTRUCTIONS .....	3-1
3-1. Operating Controls .....	3-1
3-2. Lid Operation .....	3-4
3-3. Switches and Indicators .....	3-5
3-4. Clock Set .....	3-8
3-5. Filling or Adding Shortening .....	3-10
3-6. Product Racking Recommendations .....	3-11
3-7. Basic Operation .....	3-12
3-8. Care of the Shortening .....	3-16
3-9. Filtering Instructions .....	3-16
3-10. Changing the Filter Envelope .....	3-19
3-11. Lighting and Shutdown of the Burners .....	3-21
3-12. Cleaning the Frypot .....	3-22
3-13. Filter Pump Motor Protector-Manual Reset .....	3-24
3-14. Regular Maintenance Schedule .....	3-24
3-15. Preventive Maintenance .....	3-25
3-16. Programming .....	3-30
3-17. Special Program Mode .....	3-36
3-18. Data Logging, Heat Control, Tech, and Stat Modes .....	3-43
3-19. Information Mode .....	3-44
Section 4. TROUBLESHOOTING .....	4-1
4-1. Troubleshooting Guide .....	4-1
4-2. Error Codes .....	4-2

Distributors Lists - Domestic and International



## SECTION 1: INTRODUCTION

### 1-1. PRESSURE FRYER

The Henny Penny Pressure Fryer is a basic unit of food processing equipment which is used only in institutional and commercial food service operations.

#### **P-H-T**

A combination of pressure, heat, and time is automatically controlled to produce the optimum in a tasty, appealing product.

#### **PRESSURE**

Pressure is basic to this method of food preparation. The pressure is developed from the natural moisture of the food. The patented lid traps this moisture and uses it as steam. Because the steam builds rapidly, a greater part of the natural juices are retained within the food. A deadweight assembly vents excess steam from the pot and maintains constant live steam pressure.

#### **HEAT**

Heat generated is another important factor of the pressure fryer. Energy savings is realized due to the unit's short frying time, low temperature, and heat retention of the stainless steel frypot.

#### **TIME**

Time is important because the shorter time involved in frying foods results in additional economies for the user. Foods are table ready in less time than it would take to fry them in a conventional open-type fryer.



### **NOTICE**

As of August 16, 2005, the Waste Electrical and Electronic Equipment directive went into effect for the European Union. Our products have been evaluated to the WEEE directive. We have also reviewed our products to determine if they comply with the Restriction of Hazardous Substances directive (RoHS) and have redesigned our products as needed in order to comply. To continue compliance with these directives, this unit must not be disposed as unsorted municipal waste. For proper disposal, please contact your nearest Henny Penny distributor.

### 1-2. PROPER CARE

As in any unit of food service equipment, the Henny Penny Pressure Fryer does require care and maintenance. Requirements for the maintenance and cleaning are contained in this manual and must become a regular part of the operation of the unit at all times.

### 1-3. ASSISTANCE

Should you require outside assistance, call your local independent distributor in your area, call Henny Penny Corp. at 1-800-417-8405 or 1-937-456-8405, or go to Henny Penny online at [www.hennypenny.com](http://www.hennypenny.com).

**1-1  
SAFETY**

The instructions in this manual have been prepared to aid you in learning the proper procedures for your equipment. Where information is of particular importance or is safety related, the words NOTICE, CAUTION, or WARNING are used. Their usage is described below.

If a problem occurs during the first operation of a new unit, recheck the Installation Section of the Operator's Manual.

Before troubleshooting, always recheck the Operation Section of the Operator's Manual.

Where information is of particular importance or is safety related, the words DANGER, WARNING, CAUTION, or NOTICE are used. Their usage is described as follows:



SAFETY ALERT SYMBOL is used with DANGER, WARNING or CAUTION which indicates a personal injury type hazard.



NOTICE is used to highlight especially important information.



*CAUTION used without the safety alert symbol indicates a potentially hazardous situation which, if not avoided, may result in property damage.*



*CAUTION used with the safety alert symbol indicates a potentially hazardous situation which, if not avoided, could result in minor or moderate injury.*



**WARNING indicates a potentially hazardous situation which, if not avoided, could result in death or serious injury.**



**DANGER INDICATES AN IMMINENTLY HAZARDOUS SITUATION WHICH, IF NOT AVOIDED, WILL RESULT IN DEATH OR SERIOUS INJURY.**

## SECTION 2: INSTALLATION

### 2-1. INTRODUCTION

This section provides the installation and unpacking instructions for the Henny Penny PFG-691.

#### NOTICE

Installation of this unit should be performed only by a qualified service technician.



Do not puncture the fryer with any objects such as drills or screws as electrical shock or component damage could result.

### 2-2. UNPACKING INSTRUCTIONS

#### NOTICE

Any shipping damage should be noted in the presence of the delivery agent and signed prior to his or her departure.

1. Cut and remove the plastic bands from the main box.
2. Remove the box lid and lift the main box off the fryer.
3. Remove four corner packing supports.
4. Cut the stretch film from around the carrier/rack box and remove it from the top of the fryer lid.
5. Cut and remove the metal bands holding the fryer to the pallet.



All counterweights must be loaded before unlatching the lid, or personal injury could result.

6. Remove the fryer from the pallet.



Take care when moving the fryer to prevent personal injury. The fryer weighs approximately 935 lbs. (424 kg).

**2-2.  
UNPACKING  
INSTRUCTIONS  
(CONT.)**

1. Remove the counterweights, which are strapped to the pallet under the fryer, from the pallet.



*Do not drop. The counterweights weigh approximately 18 lbs. (8.1 kg) each. Handle with care, or personal injury could result.*

2. Remove rear service cover.
3. Load the 7 weights into the counterweight assembly.
4. Replace rear service cover.



**To avoid personal injury and assure safe operation of unit, rear service cover must be in place.**

5. Cut warning tags from the lid assembly. The lid may now be unlatched.
6. Remove the accessories from inside the filter drain pan.

**NOTICE**

The fittings for installing the gas line are in a separate box, along with the accessories, in the filter drain pan.

7. Prepare the deadweight valve for operation

**NOTICE**

The metal shipping support is placed within the deadweight assembly housing to protect the deadweight orifice and deadweight during shipment. This support must be removed prior to installation and start-up.

- a. Unscrew the deadweight cap.
- b. Remove the deadweight.
- c. Remove and discard the shipping support.
- d. Clean the deadweight orifice with a dry cloth.
- e. Carefully place deadweight over deadweight orifice. Replace deadweight cap, finger tight.

14. Remove the protective paper from the fryer cabinet. Clean exterior surface with a damp cloth.

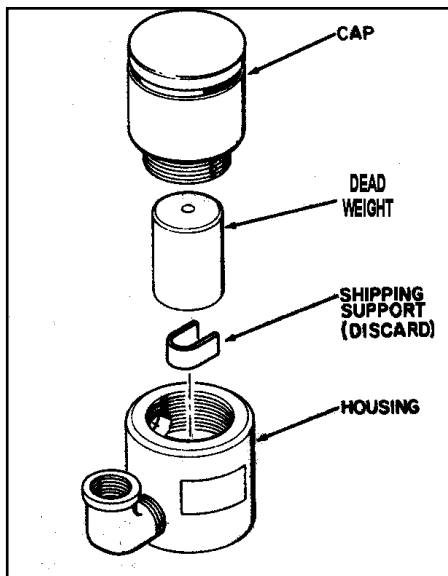

### Optional Ramp Unloading

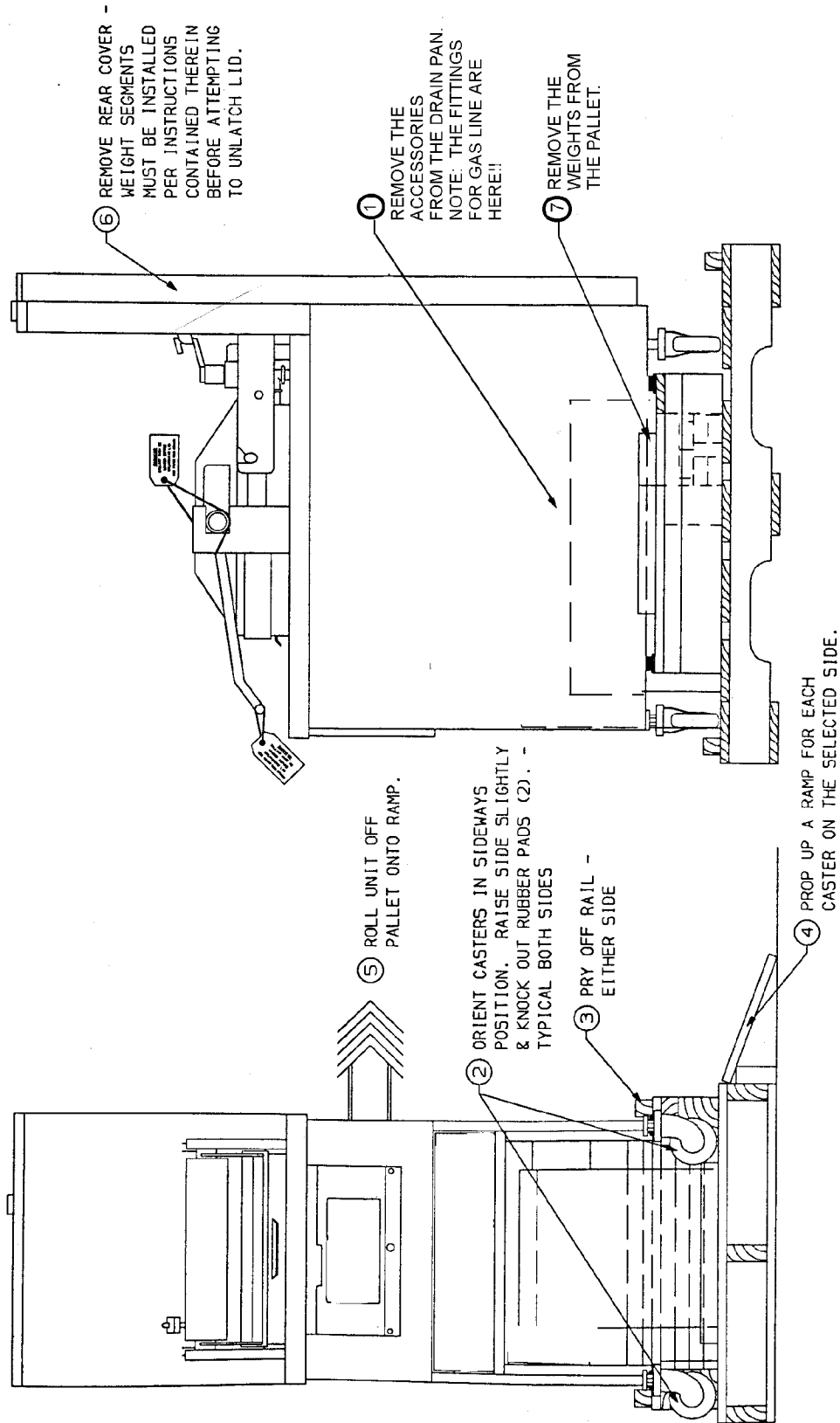

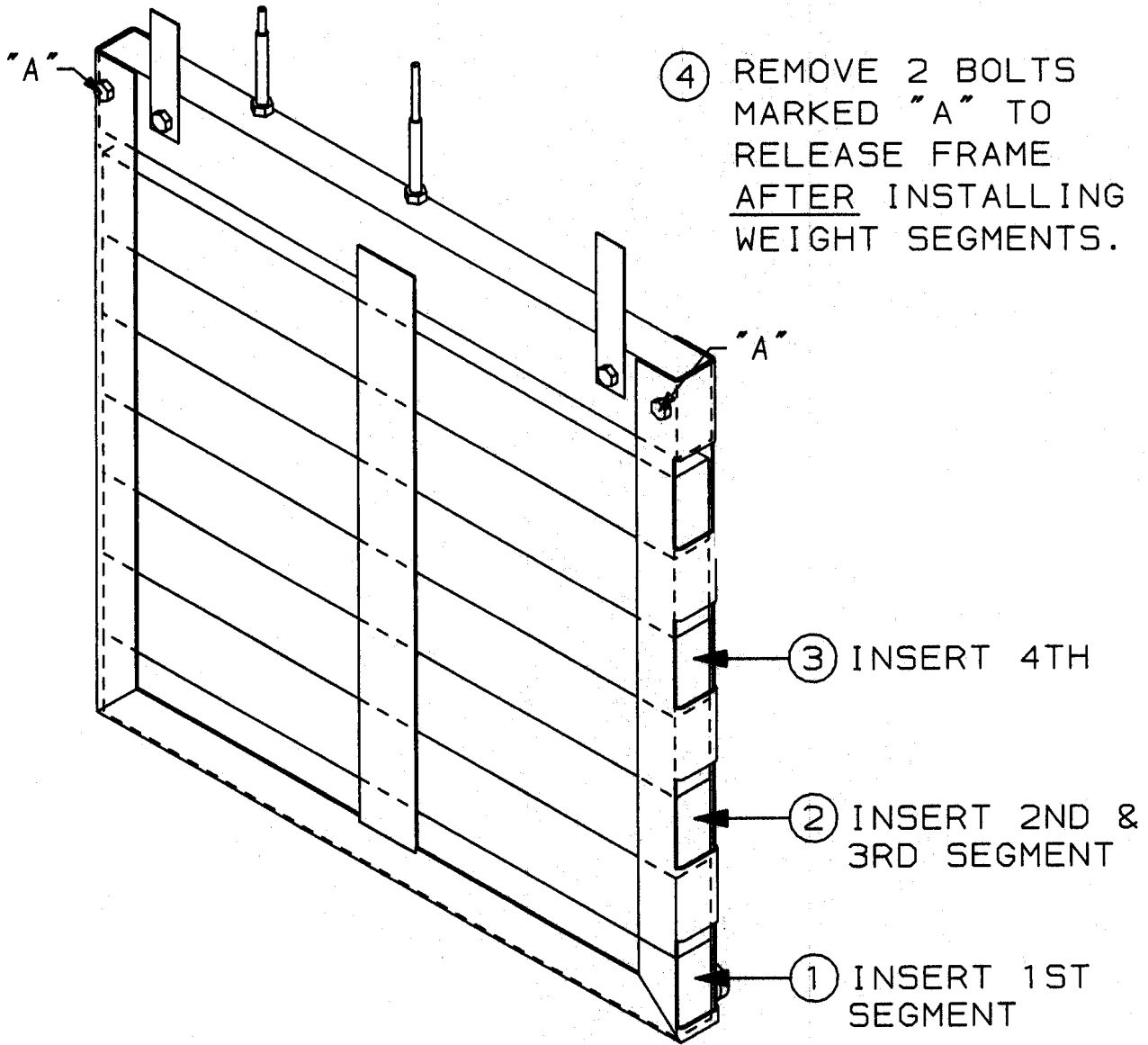

- \* EACH WEIGHT SEGMENT WEIGHS APPROXIMATELY 18 LBS. (8.1 KG) - HANDLE WITH CARE.
- \* ALL SEGMENTS ARE IDENTICAL.
- \* ALL SEGMENTS MUST BE INSTALLED AND SECURED IN THE FRAME BEFORE ATTEMPTING TO UNLATCH LID.

**2-3.  
SELECTING THE  
LOCATION**

The proper location of the fryer is very important for operation, speed, and convenience. Choose a location which will provide easy loading and unloading without interfering with the final assembly of food orders. Operators have found that frying from raw to finish, and holding the product in a warmer provides fast, continuous service. Landing or dumping tables should be provided next to, at least, one side of the fryer. Keep in mind the best efficiency will be obtained by a straight line operation, i.e., raw in one side and finish out the other side. Order assembly can be moved away with only a slight loss of efficiency. To properly service the fryer, 24 inches (60.96 cm) of clearance is needed on all sides of the fryer. Access for servicing can be attained by removing a side panel. Also, at least 6 inches (15.24 cm) around the base of the unit is needed for proper air supply to the combustion chamber.

**CAUTION  
FIRE HAZARD**

*To avoid a fire, install the fryer with minimum clearance from all combustible and noncombustible materials, 6 inches (15.24 cm) from side and 6 inches (15.24 cm) from back. If installed properly, the gas fryer is designed for operation on combustible floors and adjacent to combustible walls.*

*To avoid fire and ruined supplies, the area under the 691 fryer should not be used to store supplies.*

*Do not spray aerosols in the vicinity of this appliance while it is in operation.*

**WARNING  
BURN RISK**

**To prevent severe burns from splashing hot shortening, position and install fryer to prevent tipping or movement. Restraining ties may be used for stabilization.**

**2-4.  
LEVELING THE  
FRYER**

For proper operation, level the fryer from side to side and front to back, using level on the flat areas around the frypot collar.

**DANGER**

**FAILURE TO FOLLOW THESE LEVELING INSTRUCTIONS CAN RESULT IN SHORTENING OVERFLOWING THE FRYPOT WHICH COULD CAUSE SERIOUS BURNS, PERSONAL INJURY, FIRE, AND/OR PROPERTY DAMAGE.**

**2-5.  
VENTILATION OF  
FRYER**

The fryer must be located with provision for venting into adequate exhaust hood or ventilation system. This is essential to permit efficient removal of the flue gases and frying odors. Special precaution must be taken in designing an exhaust canopy to avoid interference with the operation of the fryer. We recommend you consult a local ventilation or heating company to help in designing an adequate system.

**NOTICE**

Ventilation must conform to local, state, and national codes. Consult your local fire department or building authorities.

**2-6.  
GAS SUPPLY**

The gas fryer is factory available for either natural or propane gas. Check the data plate on the right side panel of the cabinet to determine the proper gas supply requirements. The minimum supply for natural gas is 7 inches water column (1.74 kPa), and 10 inches water column (2.49 kPa) for propane.

**WARNING  
EXPLOSION RISK**

**Do not attempt to use any gas other than that specified on the data plate. Incorrect gas supply could cause a fire or explosion resulting in severe injuries and/or property damage.**

Please refer below for the recommended hookup of the fryer to main gas line supply.

**WARNING**

**To avoid possible serious personal injury:**

- **Installation must conform with local, state, and national codes, and be in accordance with Canadian Gas Authority Standard CSA B149-& 2, Installation Codes - Gas Burning Appliances and in accordance with Australian Gas Association current edition of AS5601 Gas Installations.**
- **The fryer and its manual shutoff valve must be disconnected from the gas supply piping system during any pressure testing of that system at test pressures in excess of 1/2 psig (3.45kPa) (34.47mbar)**  
**(continued to next page)**

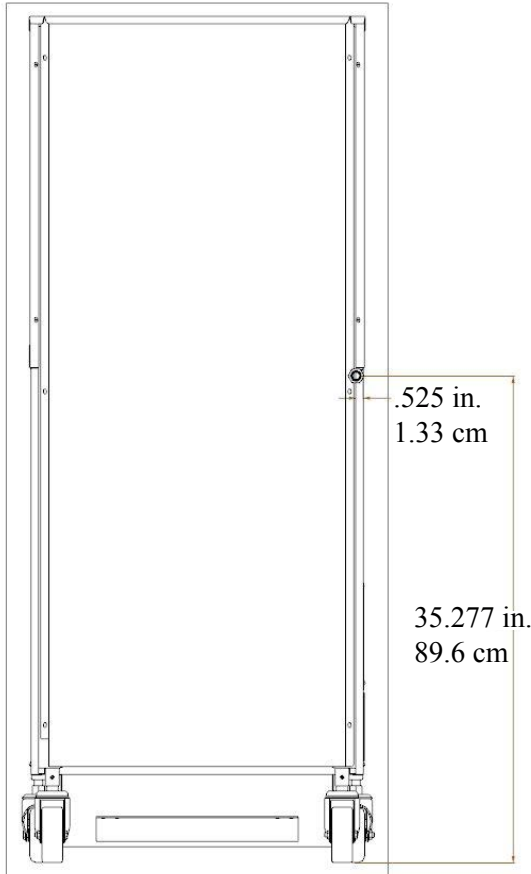

**2-6.  
GAS SUPPLY  
(CONT.)**

**WARNING**

- **The fryer must be isolated from the gas supply piping system by closing its manual shutoff valve during any pressure testing of the gas supply piping system at test pressures equal to or less than 1/2 psig (3.45 kPa)(34.47 mbar).**
- **A standard 3/4 inch, black steel pipe and malleable fittings should be used for gas service connections.**
- **Do not use cast iron fittings.**
- **Although 3/4 inch size pipe recommended, piping should be of adequate size and installed to provide a supply of gas sufficient to meet the maximum demand without undue loss of pressure between the meter and the fryer. The pressure loss in the piping system should not exceed 0.3 inch water column (0.747 mbar).**

Provisions should be made for moving the fryer for cleaning and servicing. This may be accomplished by:

1. Installing a manual gas shutoff valve and disconnect union, or
2. Installing a heavy-duty (min. 3/4 inch) design A.G.A. certified connector which complies with standard connectors for moveable gas appliances. ANSI Z21.69 or CAN/CSA 6.16. Also, a quick-disconnect coupling which complies with the Standard for Quick-Disconnect Devices for use with Gas Fuel, ANSI Z21.41 or CAN 1-6.9. Also, adequate means must be provided to limit the movement of the fryer without depending on the connector and any quick-disconnect device or its associated piping to limit the fryer movement.
3. See the illustration on the following page for the proper connections of the flexible gas line and cable restraint.

**NOTICE**

The cable restraint limits the distance the fryer can be pulled from the wall. For cleaning and servicing the fryer, the cable must be unsnapped from the unit and the flexible gas line disconnected. This will allow better access to all sides of the fryer. The gas line and cable restraint must be reconnected once the cleaning or servicing is complete.

**2-6.  
GAS SUPPLY  
(CONT.)**

**RIGHT**

MINIMUM PULL of equipment away from wall permissible for accessibility to Quick Disconnect Device.

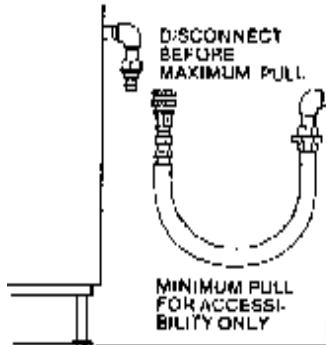

**WRONG**

AVOID SHARP BENDS AND KINKS when pulling equipment away from wall. (Maximum pull will kink ends, even if installed properly, and reduce Connector life.)

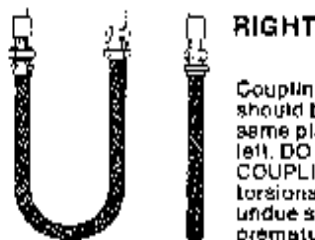
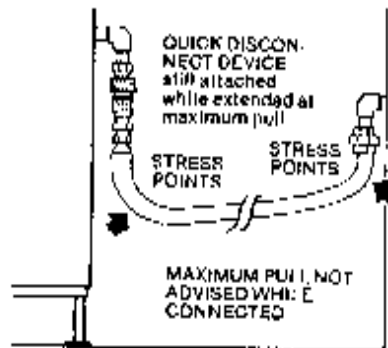

**RIGHT**  
Couplings and hose should be installed in the same plane as shown at left. **DO NOT OFFSET COUPLINGS**... this causes torsional twisting and undue strain causing premature failure.

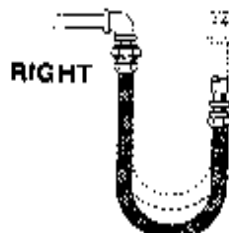

This is the correct way to install metal hose for vertical traverse. Note the single, natural loop. Allowing a sharp bend, as shown at right, strains and twists the metal hose to a point of early failure at the coupling.

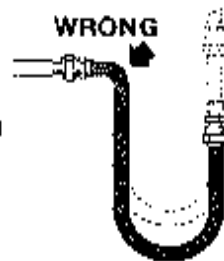

Maintain the minimum or larger bending diameter between the couplings for longest life. Closing in the diameter at the couplings, as shown at right, creates double bends causing work fatigue failure of the fittings.

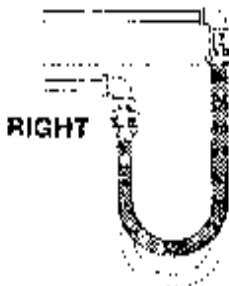

In all installations where "self-draining" is not necessary, connect metal hose in a vertical loop. **DO NOT CONNECT METAL HOSE HORIZONTALLY**... unless "self-draining" is necessary, then use support on lower plane as shown at left.



**CABLE RESTRAINT**

Please refer to the illustration below when installing cable restraint on all moveable gas fryers.

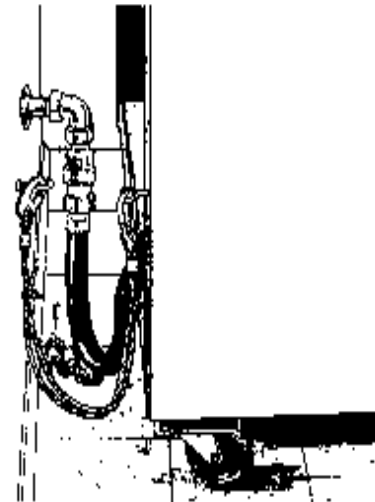

I-bolt is to be secured to the building using acceptable building construction practices.

**CAUTION**

**DRY WALL CONSTRUCTION**

Secure I-bolt to a building stud. Do not attach to dry wall only. Also, locate the I-bolt at the same height as the gas service. Preferred installation is approximately six inches to either side of service. Cable restraint must be at least six inches shorter than flexible gas line.

**CAUTION**

Utilize elbows when necessary to avoid sharp kinks or excessive bending. For ease of movement, install with a "lazy" loop. Gas appliance must be disconnected prior to maximum movement. (Minimum movement is permissible for hose disconnection).

**2-8.  
GAS PRESSURE  
REGULATOR  
SETTING**

The gas pressure regulator on the gas control valve is factory set as follows:

Natural: 3.5 inches water column (0.87 kPa)

Propane: 10.0 inches water column (2.49 kPa)

**NOTICE**

The gas pressure regulator has been set by Henny Penny and is not to be adjusted by the user.

**! DANGER**

**MAKE SURE GAS PRESSURE IS SET CORRECTLY. FAILURE TO DO SO CAN RESULT IN SHORTENING OVERFLOWING THE FRYPOT, WHICH COULD CAUSE SERIOUS BURNS, PERSONAL INJURY, FIRE, AND/OR PROPERTY DAMAGE.**

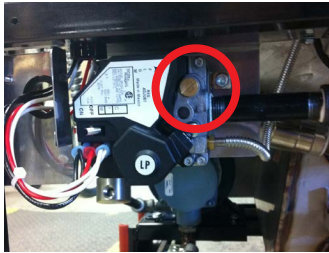

Figure 1



Figure 2



Figure 3

**MEASURING GAS PRESSURE**

1. Locate the pressure tap hole or fitting on the side of the gas valve. Remove the pipe plug from the valve or fitting circled in Figure 1.
2. Screw a pressure tap fitting into the valve or the fitting on the side of the valve circled in Figure 2.
3. Place one end of a vacuum hose on the pressure tap fitting and the other end on the manometer as shown in Figure 3.
4. Turn the fryer "ON".
5. Allow the fryer to reach full burn.
6. The pressure reading on the manometer should be 3.5" of water column for Natural gas and 10" of water column for LP gas.
7. Turn the fryer off.
8. Remove the pressure tap fitting.
9. Place the pipe plug back into the valve or the fitting on the valve.

**NOTICE**

Notify a qualified service technician if gas pressure differs from factory settings mentioned in this manual

**2-9.  
ELECTRICAL  
REQUIREMENTS**

The gas fryer requires 120 volt, 60 Hertz, 1 phase, 10 amp, 3-wire grounded (earthed) service, or 230 volt, 50 Hertz, 1 phase, 5 amp, service. The 120 volt gas fryer is factory equipped with a grounded (earthed) cord and plug for your protection against shock, and should be plugged into a three-prong grounded (earthed) receptacle. Do not cut or remove grounding (earthing) prong. A wiring diagram is located behind the right side panel, and can be accessed by removing the side panel. The 230 volt plug must conform to all local, state, and national codes.



**To avoid electrical shock, do not disconnect the ground (earth) plug. This fryer must be adequately and safely grounded (earthed). Refer to local electrical codes for correct grounding (earthing) procedures or in absence of local codes, with The National Electrical Code, ANSI/ NFPA No. 70-(the current edition). In Canada, all electrical connections are to be made in accordance with CSA C22.1, Canadian Electrical Code Part 1, and/or local codes.**

**To avoid electrical shock, this appliance must be equipped with an external circuit breaker which will disconnect all ungrounded (unearthed) conductors. The main power switch on this appliance does not disconnect all line conductors.**

**2-10.  
TESTING THE  
FRYER**

Each Henny Penny pressure fryer was completely checked and tested prior to shipment. However, it is good practice to check the unit again after installation.

**2-11.  
GAS LEAK TEST**

**NOTICE**

Prior to turning the gas supply on, be sure the gas valve knob on the gas control valve is in the OFF position. The word OFF is at the bottom of the knob when the valve is closed.

Upon initial installation, and after moving the unit, the piping and fittings should be checked for gas leaks. A simple checking method is to turn on the gas, and brush all connections with a soap solution. If bubbles occur, it indicates escaping gas. In this event, the piping connection must be redone.



**To avoid fire or explosion, never use a lighted match or open flame to test for gas leaks. Ignited gas could result in severe personal injury and/or property damage.**

**BOIL-OVER PREVENTION IN HENNY PENNY FRYERS**



**FAILURE TO FOLLOW THESE INSTRUCTIONS CAN RESULT IN SHORTENING  
OVERFLOWING THE FRYPOT WHICH COULD CAUSE SERIOUS BURNS, PERSONAL INJURY, FIRE,  
AND/OR PROPERTY DAMAGE.**

- **THE SHORTENING SHOULD BE STIRRED ONLY DURING THE MORNING START-UP PROCEDURE. DO NOT STIR THE SHORTENING AT ANY OTHER TIME.**
- **FILTER THE SHORTENING AT LEAST TWICE A DAY.**
- **FILTER ONLY WHEN “COOL” IS DISPLAYED.**
- **BRUSH ALL CRACKLINGS FROM FRYPOT SURFACES AND THE COLD ZONE DURING THE FILTERING PROCESS.**
- **MAKE SURE THE FRYER IS LEVEL.**
- **BE CERTAIN THE SHORTENING IS NEVER ABOVE THE UPPER FRYPOT LEVEL INDICATOR LINES.**
- **BE CERTAIN THAT THE GAS CONTROL VALVE AND BURNERS ARE PROPERLY ADJUSTED (GAS UNITS ONLY).**
- **USE RECOMMENDED PRODUCT LOAD SIZE.**

**FOR ADDITIONAL INFORMATION ON THESE INSTRUCTIONS, REFER TO THE HENNY PENNY  
OPERATOR’S MANUAL**

**FOR ASSISTANCE, CALL THE HENNY PENNY SERVICE DEPARTMENT AT  
1-800-417-8405 OR 1-937-456-8405.**



## SECTION 3: OPERATION

### 3-1. OPERATING COMPONENT

#### **POWER/PUMP SWITCH**

A three-way switch with center OFF position; move the switch to the position marked POWER to operate the fryer; move the switch to the position marked PUMP to operate the filter pump; certain conditions must be met prior to operation of the filter pump; these conditions are covered later in this section

#### **FRYPOT**

This reservoir holds the cooking shortening, and is designed to accommodate the burner tubes, 8 head of product, and an adequate cold zone for collection of cracklings

#### **CARRIER**

This stainless steel carrier consists of five racks, containing the food product during and after frying (4 cook racks and 1 cover rack)

#### **LID GASKET**

Provides the pressure seal for the frypot chamber

#### **DEADWEIGHT ASSEMBLY**

The deadweight style operating pressure relief valve is used to maintain a constant level of steam pressure within the frypot; any excess steam pressure is vented through the exhaust stack; remove the deadweight cap, and clean the cap, deadweight, and deadweight orifice once a day; see Preventive Maintenance Section



**Failure to clean the deadweight assembly daily could result in the fryer building too much pressure. Severe injuries and burns could result.**

#### **SAFETY RELIEF VALVE**

An ASME approved spring loaded valve set at 14.5 psi (999 mbar); in the event the operation valve becomes obstructed, this safety valve will release excess pressure, keeping the frypot chamber at 14.5 psi (999 mbar); if this occurs, turn the COOK/PUMP switch to the OFF position to release all pressure from the frypot

**3-1.  
OPERATING  
COMPONENT  
(CONT.)**

**SAFETY RELIEF VALVE RING**



**DO NOT PULL THIS RING. SEVERE BURNS  
FROM THE STEAM WILL RESULT**

**PRESSURE GAUGE**

Indicates the pressure inside the frypot

**SOLENOID VALVE**

An electromechanical device that causes pressure to be held in the frypot

The solenoid valve closes at the beginning of the Cook Cycle and opens automatically at the end of the Cook Cycle; if this valve becomes dirty or the teflon seat nicked, pressure will not build and it must be repaired per the Maintenance Section of the Technical Manual

**DRAIN VALVE**

A two-way ball valve, normally in the closed position; turn the handle to drain the shortening from the frypot into the filter drain pan



**DO NOT OPEN THE DRAIN VALVE WHILE  
FRYPOT IS UNDER PRESSURE. HOT  
SHORTENING WILL EXHAUST, AND SEVERE  
BURNS WILL RESULT.**

**DRAIN INTERLOCK SWITCH**

A microswitch that provides protection for the frypot in the event an operator inadvertently drains the shortening from the frypot while the main switch is in the COOK position; the switch is designed to automatically shut off the heat when the drain valve is opened

**CONDENSATION DRAIN PAN**

The collection point for the condensation formed within the steam exhaust system; it must be removed and emptied periodically, usually daily

**SHORTENING MIXING SYSTEM**

The unit is equipped with a shortening mixing capability to ensure the shortening is properly mixed to prevent an accumulation of moisture, causing boiling action in the frypot; the filter pump is activated by the controls, at preset intervals, to mix the shortening

**LID LATCH**

The fryer lid is equipped with a mechanical catch on the front of the lid which engages a bracket on the front of the frypot; this device holds the lid down while the lid is being locked into place, but is not meant to hold pressure in the frypot

**3-1.  
OPERATING  
COMPONENT  
(CONT.)**



High limit reset

**HIGH TEMPERATURE LIMIT**

This is a safety component that senses the temperature of the shortening; if the temperature of the shortening exceeds 420°F (216°C), this control opens and shuts off the heat to the frypot; when the temperature of the shortening drops to a safe operation limit, the control must be manually reset by pressing the red reset button, located under the control panel, in the right, front of the fryer

**IGNITION MODULES**

The two ignition modules send 24 volts to the gas control valve and high voltage to the ignitors

**SPARK IGNITORS**

When the pilots are being lit, the spark ignitors are electrically energized and the tip of the ignitors spark to ignite the pilot lights

**FLAME SENSORS**

Sense the pilot lights when the power switch is turned on; if the pilots go out, or do not light, the flame sensors shut the gas off, via the modules

**GAS CONTROL VALVE**

A dual controller in which one side of the valve controls the pilot light and the other side controls the main burner

**AIRFLOW SWITCH**

Senses the flow of air coming from the blower; if the airflow is reduced below a set amount, the switch cuts power to the gas control valve, which shuts down the burners

**CAUTION**

*To avoid property damage, do not tamper with or disassemble this component. It is set and sealed from the factory and is not to be adjusted.*

**BLOWER**

Adds the proper amount of air into the burner tubes, so an efficient combustion takes place, and also, pulls the flue gases out to the flue

**AIR VALVE**

Pumps air into the shortening, periodically, to keep the shortening at a uniform temperature; this only functions when the unit has been sitting idle for a period of time, and when heating up from a cold start

**3-2.  
LID OPERATION**

**TO CLOSE LID:**

1. Lower the lid until gasket comes into contact with the pot and lock the lid in place with the lid latch.
2. Pull lid handle forward until it stops.
3. Lift up on the lid handle until it stops.
4. Bring lid handle out towards you until it stops.
5. Push lid handle down, locking lid in place.

** DANGER**

**LID MUST BE LATCHED PROPERLY, OR PRESSURIZED SHORTENING AND STEAM MAY ESCAPE FRYPOT. SEVERE BURNS WILL RESULT.**

**DO NOT LIFT HANDLE OR FORCE LID LATCH OPEN BEFORE PRESSURE GAUGE READS "0" PSI. ESCAPING STEAM AND SHORTENING WILL RESULT IN SEVERE BURNS.**

**TO AVOID SERIOUS PERSONAL INJURY, DO NOT OPERATE WITHOUT LID COVER IN PLACE AND ALL COMPONENTS INSTALLED.**

**TO AVOID SERIOUS PERSONAL INJURY, DO NOT TAMPER WITH ANY COMPONENT OF LID LOCKING MECHANISM.**

**NOTICE**

If lid becomes difficult to operate, stop using the fryer and call for service. Cables need replaced.

**TO OPEN LID:**







1. Gently raise handle until it stops.
2. Push handle back until it stops.
3. Lower handle.

**CAUTION**



*Lower the handle before attempting to raise the lid, or damage to the lid could result.*

4. Push handle back.
5. Unlatch the front lid latch.

**3-3.  
SWITCHES AND  
INDICATORS**

Fig. No.	Item No.	Description	Function
3-1	1		Lights when the control calls for heat; the elements come on and heat the shortening
3-1	2	Digital Display	Shows all the functions of the Cook Cycles, program modes, diagnostic modes, and alarms
3-1	3		Lights when the solenoid closes and pressure starts to build inside frypot
3-1	4		Flashes when the shortening temperature is not at the proper temperature for cooking product
3-1	5		Lights when the shortening temperature is 5° F (3° C) below
3-1	6	 (◀INFO)	<p>Press to display the following fryer information and status:</p> <ol style="list-style-type: none"> <li>The temperature of the shortening</li> <li>The temperature setpoint</li> <li>The number of Cook Cycles until Filter Lockout, if turned on</li> <li>If a Change Shortening function is enabled (SP17 or SP18), the percentage of Cook Cycles or hours is shown</li> <li>Date and time</li> </ol> <p>If pressed in the Program Mode, shows previous settings; pressing this along with (PROG▶) accesses the Information</p> <p>Mode which has historic information on the operator and fryer's performance</p>
3-1	7 & 8		Used to adjust the value of the currently displayed setting in the Program modes

**3-3.  
SWITCHES AND  
INDICATORS  
(CONT.)**

3-1	9	 (PROG▶)	<p>Press to access Program Modes; once in the Program Mode, it is used to advance to the next setting; if pressed along with (◀INFO) , it accesses the Information Mode</p> <p>which has historic information on the operator and fryer's performance</p>
3-1	10	 Timer Button	<p>Used to start and stop Cooking Cycles, and to stop the timer at the end of a Holding Cycle</p>
3-1	11	Menu Card Window	<p>The name of the food product associated with each product selection button; the menu card strip is located behind the decal</p>
3-1	12	Product Select Buttons	<p>Are used to select the product for cooking; to use them to start Cooking Cycles, see Special Program Mode section</p>
3-1	13	COOK/PUMP Switch	<p>A 3-way switch with a center OFF position; turn the switch to the COOK position to operate the fryer; turn the switch to the PUMP position to operate the filter pump; certain conditions must be met before operating the filter pump; these conditions are covered later in the Filtering Instructions Section of this manual</p>
3-1	14	 IDLE Button	<p>Used to manually enter an Idle mode, or Clean-Out Mode</p>

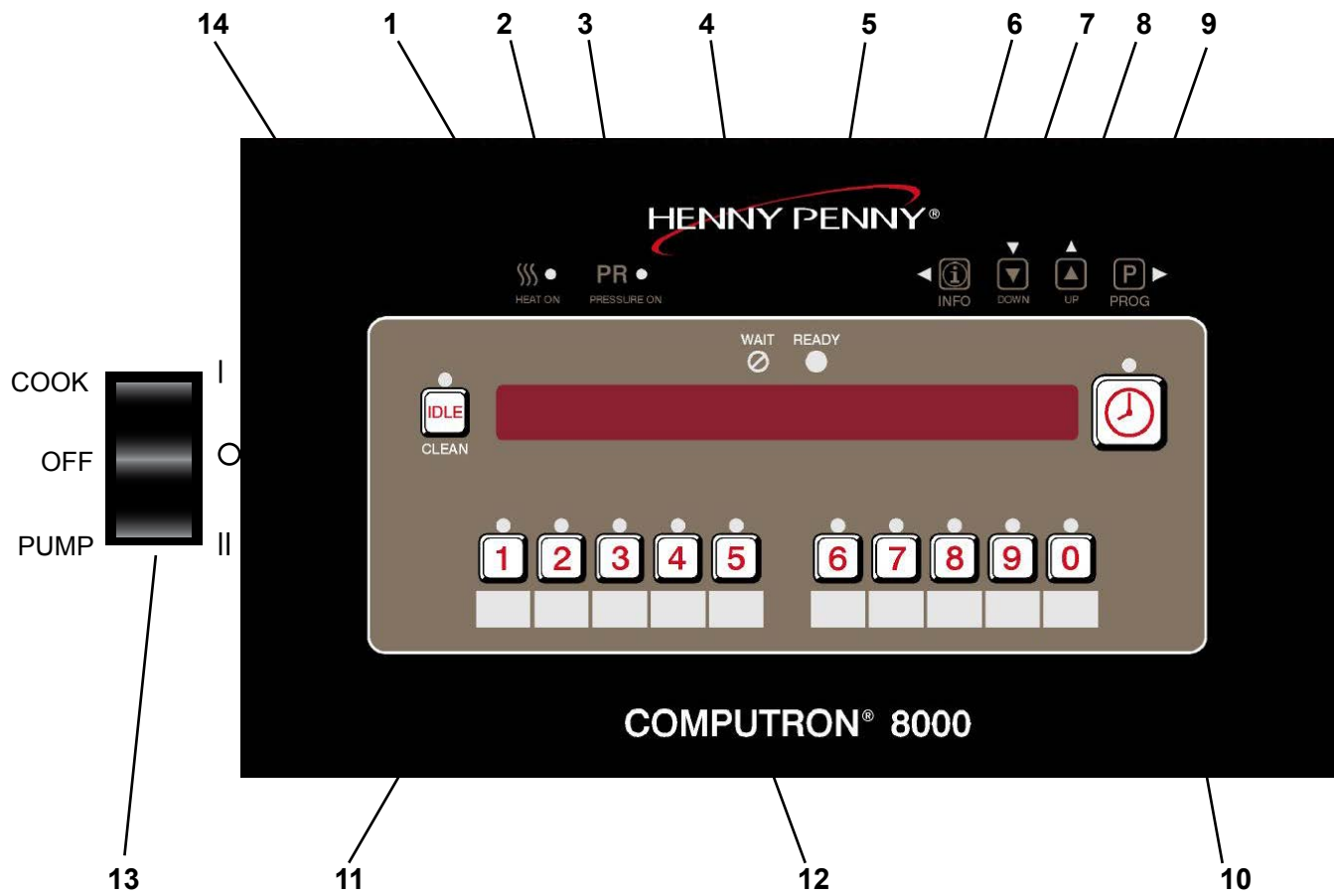

Figure 3-1. Control Panel

**3-4  
CLOCK SET**

**NOTICE**

Upon initial start-up, or PC board replacement, if “CLOCK SET” automatically appears in the display, start with step 4.

1. Press and hold (PROG▶) for 5 seconds until “LEVEL 2” shows in display.
2. Press (PROG▶) and “CLOCK SET”, “ENTER CODE” shows in display.
3. Press 1, 2, 3.
4. “CS-1, SET, MONTH”, and the month flashes in the display.
5. Press the ▼▲ to change the month.
6. Press (PROG▶) and “CS-2, SET, DATE” shows in the display, with the date flashing.
7. Press ▼▲ to change the date.
8. Press (PROG▶) and “CS-3, SET, YEAR” shows in the display, along with the year flashing.
9. Press ▼▲ to change the year.
10. Press (PROG▶) and “CS-4, SET, HOUR” shows in the display, with the hour and “AM” or “PM” flashing.
11. Press ▼▲ to change the hour and AM/PM setting.
12. Press (PROG▶) and “CS-5, SET, MINUTE” shows in the display, with the minutes flashing.
13. Press ▼▲ to change the minutes.

**3-4**  
**CLOCK SET**  
**(CONT.)**

14. Press (PROG▶) and “CS-6, CLOCK MODE” shows in the display, along with “1.AM/PM”. “1.AM/PM” is 12 hour time, “2.24-HR” is 24 hour time. Press ▼▲ to change.
15. Press (PROG▶) and “CS-7, DAYLIGHT SAVINGS ADJ” shows in the display, along with “2.US”. Press ▼▲ to change to the following:
  - a. “1.OFF” = No automatic adjustments for Daylight Savings Time.
  - b. “2.US” = Automatically applies United States Daylight Savings Time adjustment. DST activated on the first Sunday in April. DST deactivated on the last Sunday in October.
  - c. “3.EURO” = Automatically applies European (CE) Daylight Saving Time adjustment. DST activated on the last Sunday in March. DST deactivated on the last Sunday in October.
16. Press (PROG▶) and “CS-8, BEGIN NEW DAY” shows in display, along with “3:00AM”.

This setting indicates the time of day that statistics start accumulating for a new day. If set to 3:00AM, for example, then late night cook cycles and filter operations from midnight to 3:00AM Tuesday morning, are accumulated with Monday’s statistics.

The CS-8 value can be set from 12:00AM (midnight) to 8:00AM, in half hour increments (12:00 AM, 12:30 AM, 1:00 AM, 1:30 AM, etc.). The default value for general market software is 3:00 AM.

Press ▼▲ to change the time the new day starts.

17. Clock Set is now complete. Press and hold (PROG▶) to exit.

**3-5.  
FILLING OR  
ADDING  
SHORTENING**

**CAUTION**

*The shortening level must always be above the burner tubes when the fryer is heating and at the frypot level indicators on the rear of the frypot (See photo below). Failure to follow these instructions could result in a fire and/or damage to the fryer.*

*When using solid shortening, it is recommended to melt the shortening on an outside heating source before placing it in the frypots. The burner tubes must be completely submerged in shortening. Fire or damage to the frypot could result.*

1. It is recommended that a high quality shortening be used in the fryer. Some low grade shortenings have a high moisture content and will cause foaming and boiling over.



**WARNING**  
**BURN RISK**

**To avoid severe burns when pouring hot shortening into frypot, wear gloves and take care to avoid**

2. The gas model requires 130 lbs. (59 kg) of shortening. The frypot has 4 level indicator lines inscribed on the rear wall of the frypot which show when the heated shortening is at the proper level. See photo at left.
3. Cold shortening should be filled to the lower indicators.

**DANGER**  
**OVERFLOW RISK**

**BE CERTAIN THE SHORTENING IS NEVER ABOVE THE UPPER LEVEL INDICATOR LINES. FAILURE TO FOLLOW THESE INSTRUCTIONS CAN RESULT IN SHORTENING OVERFLOWING THE FRYPOT CAUSING SERIOUS BURNS, PERSONAL INJURY, FIRE AND/OR PROPERTY DAMAGE.**

**3-6.  
PRODUCT RACKING/  
RECOMMENDATIONS**

The rack positions are referenced starting at the bottom:

Load Type	
4	
3	
2	
1	

The bottom position is to be avoided on small loads because it is closer to the cold zone. (The oil is cooler at the bottom of the frypot and hotter at the top.) With bigger loads, however, there is generally enough turbulence in the oil that the bottom rack gets sufficient heat.

The top position is to be avoided on small loads because of insufficient oil coverage. With bigger loads, the top rack has good oil coverage because the volume of product on the lower racks raises the overall oil level.

Cooking ONE rack (2-head load)	
4	
3	
2	00000000000000
1	

Cooking TWO rack (4-head load)	
4	
3	00000000000000
2	00000000000000
1	

Cooking THREE rack (6-head load)	
4	
3	00000000000000
2	00000000000000
1	00000000000000

Cooking FOUR rack (8-head load)	
4	00000000000000
3	00000000000000
2	00000000000000
1	00000000000000

**3-6.  
BASIC OPERATION**

Follow the procedure below on the initial start-up of the fryer and each time the fryer is brought back into operation from a cold, or shutdown condition, . These are basic, general instructions.

1. Make sure the shortening is filled to the two lower level indicators in the frypot.

**⚠ DANGER**

**OVERFLOW RISK**

**DO NOT OVERLOAD, OR PLACE PRODUCT WITH EXTREME MOISTURE CONTENT INTO THE RACKS. 32 LBS. (14.5 KG) IS THE MAXIMUM AMOUNT OF PRODUCT PER FRYPOT. FAILURE TO FOLLOW THESE INSTRUCTIONS CAN RESULT IN SHORTENING OVERFLOWING THE FRYPOT WHICH COULD CAUSE SERIOUS BURNS, PERSONAL INJURY, FIRE AND/OR PROPERTY DAMAGE.**

2. Turn the POWER/PUMP switch to the POWER position and press the appropriate product button to select the amount of product to be cooked.

**NOTICE**

The controls have a 45-second delay from when the power switch is turned on to when the burners ignite.

All safety devices shut off the gas supply to the burner.

Follow the above procedures to restart the fryer.

Notify a qualified service technician if the shutdown is repeated.

3. Stir the shortening as it is heating up from a cold start. Be sure to stir down into the cold zone.

**⚠ DANGER**

**OVERFLOW RISK**

**DO NOT STIR THE SHORTENING AT ANY OTHER TIME EXCEPT AT MORNING START-UP. FAILURE TO FOLLOW THESE INSTRUCTIONS CAN RESULT IN SHORTENING OVERFLOWING THE FRYPOT WHICH COULD CAUSE SERIOUS BURNS, PERSONAL INJURY, FIRE, AND/OR PROPERTY DAMAGE.**

**3-6.  
BASIC OPERATION  
(CONT.)**

4. Allow fryer to heat until READY illuminates.

**NOTICE**

Bypass Melt Cycle, if desired, by pressing a Product button and holding it for five seconds. The display shows "EXIT MELT? 1=YES 2=NO". Press 1 button to exit melt.

**CAUTION**

*Do not bypass the Melt Cycle unless enough shortening has melted to completely cover all of the burner tubes. If the Melt Cycle is bypassed before all burner tubes are covered, excessive smoking of shortening or a fire will result.*

**NOTICE**

The heat cycles on and off about 10°F (6°C) before the setpoint temperature, to help prevent overshooting the setpoint temperature. (Proportional Control)

Once out of the Melt Cycle, WAIT flashes until 5°F (3°C) before setpoint temperature is reached. Then READY illuminates and the selected product shows in the display.

5. Slide racks of breaded product into carrier on the lid, starting with the bottom tier, to avoid damaged product.

**NOTICE**

Before loading product onto the racks, lower the racks into the hot shortening to prevent the product sticking to the racks.

6. Lower and lock the lid, and press TIMER button.

**NOTICE**

A different product can be selected during the first minute of cooking, in case the wrong product button was pressed. To check the shortening temperature, press (◀INFO) or to stop a cook cycle, press the TIMER button.

**WARNING**

**To avoid property damage do not leave fryer unattended.**

**3-6.  
BASIC OPERATION  
(CONT.)**

7. At the end of the cycle, the pressure vents automatically and an alarm sounds, while the display shows “DONE”. Then, press TIMER button.
8. Wait for the pressure gauge to show zero (0) pressure in the pot before attempting to open the lid.



**DO NOT LIFT HANDLE OR FORCE LID LATCH OPEN BEFORE PRESSURE GAUGE READS “0” PSI. ESCAPING STEAM AND SHORTENING WILL RESULT IN SEVERE BURNS.**

9. Unlock and raise the lid cautiously.
10. Using the rack handles, remove the racks of product from the carrier, starting with the top rack, to avoid damaged product.
11. If a quality time (hold time) was programmed, the controller automatically starts the hold timer. The display alternately shows the product selected and the quality time remaining in minutes. If a different product is selected during the Hold Cycle, the display only shows the product selected.

At the end of the Hold Cycle, a tone sounds, the display flashes “QUALITY”, and the product it was timing. Press and release TIMER button.

**NOTICE**

In a Cook Cycle, when “FILTER SUGGESTED”, shows in the display, the operator has the option to filter at this time, or to continue cooking. But, if the operator continues cooking, a Filter Lockout occurs within the next Cook Cycle, or two.

When “**FILTER LOCKOUT**”, then “**YOU \*MUST\*FILTER NOW.....**” shows in the display, (PROG▶) is the only button that functions, until the unit is filtered. Follow the filtering instructions in this manual.

**3-6.  
BASIC OPERATION  
(CONT.)**

Once filtering is complete and the COOK/PUMP switch is turned back on, “IS POT FILLED” shows in the display, followed by “1=YES 2=NO”.

If shortening is at the proper level in the frypot, press 1 button and the controls start a normal heating process.

If shortening is NOT at the proper level, press 2 button and “TURN OFF UNTIL FILLED...” scrolls through the display. Turn the COOK/PUMP switch to the OFF position, fill frypot to the proper level, then turn the COOK/PUMP switch back to the COOK position.

Again, “IS POT FILLED” shows in the display, followed by “1=YES 2=NO”. This time press 1 button and unit resumes normal heating process.

**CAUTION**

*When the fryer is heating, the shortening level must always be above the heating elements. Failure to follow these instructions could result in a fire and/or damage to the fryer.*

**3-8.  
CARE OF THE  
SHORTENING**

**⚠ DANGER**  
**OVERFLOW RISK**

**FOLLOW THE INSTRUCTIONS BELOW TO AVOID SHORTENING OVERFLOWING THE FRYPOT, WHICH COULD RESULT IN SERIOUS BURNS, PERSONAL INJURY, FIRE, AND/OR PROPERTY DAMAGE.**

1. To protect the shortening when the fryer is not in immediate use, the fryer should be put into the IDLE mode.
2. Frying breaded products requires filtering to keep the shortening clean. The shortening should be filtered at least twice a day: after lunch rush and at the end of the day.
3. Maintain the shortening at the proper cooking level. Add fresh shortening as needed.
4. Do not overload the basket with product or place product with extreme moisture content into basket.

**⚠ DANGER**  
**FIRE HAZARD**

**WITH PROLONGED USE, THE FLASHPOINT OF SHORTENING IS REDUCED. DISCARD SHORTENING IF IT SHOWS SIGNS OF EXCESSIVE SMOKING OR FOAMING. SERIOUS BURNS, PERSONAL INJURY, FIRE, AND/OR PROPERTY DAMAGE COULD RESULT.**

**3-9.  
FILTERING  
INSTRUCTIONS**

The Henny Penny 8 Head Gas Fryer, Model PFG-691, must be cleaned and the shortening filtered at least twice daily: after lunch rush and at the end of the day.

**CAUTION**

*Drain the shortening at 275°F (135°C) or less. The higher temperatures cause cracklings to burn on the steel frypot surfaces after the shortening has drained.*

**3-9.  
FILTERING  
INSTRUCTIONS  
(CONT.)**

**⚠ DANGER  
OVERFLOW RISK**

**ONLY FILTER WHEN THE SHORTENING TEMPERATURE IS LESS THAN 275° F (135° C). FAILURE TO DO SO CAN RESULT IN SHORENNG OVERFLOWING THE FRYPOT, CAUSING SERIOUS BURNS, PERSONAL INJURY, AND/OR PROPERTY DAMAGE.**

High-volume cooking could cause the cold zone to fill quicker with cracklings, and cleaning may be required more often. Part of the process involves removing cracklings from the cold zone of the frypot.

1. Turn COOK/PUMP switch OFF before draining shortening.
2. Make sure drain pan is under fryer and the filter union is tightened to the standpipe, coming out of the pan.

**⚠ WARNING**

**The filter pan must be as far back under fryer as it will go, and the cover in place. Be sure the hole in the cover lines up with the drain before opening the drain. Failure to follow these instructions causes splashing of shortening and could result in personal injury.**

**Surfaces of fryer and racks will be hot. Use care when filtering to avoid getting burned.**

**SHORTENING  
STIRRER**

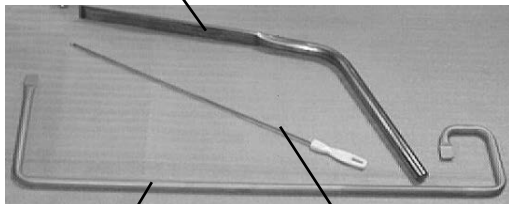

**DRAIN CLEANOUT  
ROD**

**SMALL WHITE  
BRUSH**

3. Remove cooking racks and wipe bottom of lid. Tilt lid out of the way to clean frypot.
4. Pull drain handle towards you to open drain valve. The handle should point straight out to the front of the fryer. Use L-shaped brush to clean cracklings from the heat tubes and from sides and bottom of frypot as shortening drains. Use straight brush to push cracklings through drain opening in bottom of frypot if necessary, and to clean between the burner tubes and the frypot wall.

**3-9.  
FILTERING  
INSTRUCTIONS  
(CONT.)**

**⚠ DANGER**  
**OVERFLOW RISK**

**BRUSH ALL CRACKLINGS FROM FRYPOT SURFACES AND THE COLD ZONE DURING THE FILTERING PROCESS. FAILURE TO DO SO CAN RESULT IN SHORTENING OVERFLOWING THE FRYPOT, WHICH COULD CAUSE SERIOUS BURNS, PERSONAL INJURY, FIRE, AND/OR PROPERTY DAMAGE.**

5. When all of the shortening has drained, scrape or brush the sides and bottom of the frypot, and swing drain valve handle to the closed position.

**CAUTION**

*Do not bang the pot scraper, or other cleaning utensil, on the frypot rim. Damage to the frypot rim could result and the lid may not seal properly during a cook cycle.*

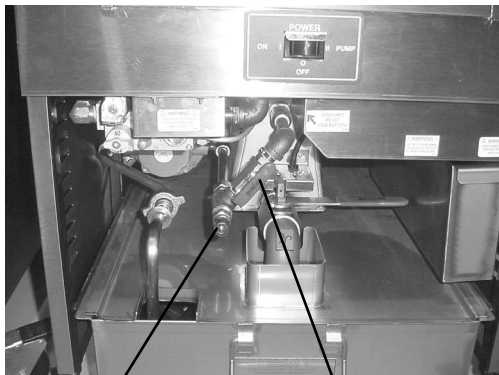

**MALE FITTING      FILTER VALVE HANDLE**

6. If an optional filter rinse hose is available on your fryer, the following cleaning procedure may be used, otherwise continue onto step 7.
  - a. Attach the filter rinse hose with its filter union fitting to the male fitting, located next to the filter valve handle. Slide back the spring ring on the female side of the filter union fitting and let it snap into place over the male half of the fitting.
  - b. Make sure the hose nozzle is pointed down into the bottom of the frypot and filter valve is in closed position. Move the power/pump switch to the PUMP position. Hold nozzle carefully to avoid excessive splashing.

**⚠ WARNING**  
**BURN RISK**

**Use care to prevent burns caused by splashing of hot shortening.**

**3-9.  
FILTERING  
INSTRUCTIONS  
(CONT.)**

- c. Rinse the frypot interior. Especially work on hard-to-clean areas, like the frypot bottom and burner tubes.
- d. After thorough rinsing with shortening, close the drain valve.
- e. Turn the COOK/PUMP switch to the OFF position.

**⚠ DANGER  
BURN RISK**

**ONLY CONNECT AND DISCONNECT THE FILTER RINSE HOSE WHEN THE MAIN POWER SWITCH IS IN THE OFF POSITION. ALSO, USE A DRY CLOTH OR GLOVE TO AVOID BURNS. FAILURE TO DO THIS COULD RESULT IN SEVERE BURNS FROM HOT SHORTENING SPRAYING FROM THE MALE FITTING.**

- f. Detach the hose and raise the fitting end of hose high for a minute to allow the remaining shortening in the hose to drain into the frypot.
7. Push the drain handle to the closed position to close the drain.
  8. Turn COOK/PUMP switch to PUMP.

**⚠ DANGER  
BURN RISK**

**IF THERE ARE AIR BUBBLES COMING UP IN THE SHORTENING, IT'S POSSIBLE THAT THE FILTER CONNECTION AT THE UNION ON THE FILTER TUBE IS NOT TIGHTENED PROPERLY. IF SO, TURN OFF THE PUMP AND USE PROTECTIVE CLOTH OR GLOVE WHEN TIGHTENING THE UNION. THIS UNION WILL BE HOT AND SEVERE BURNS COULD RESULT.**

9. When all shortening has been pumped into frypot, turn COOK/PUMP switch to OFF.

The filter envelope should be changed after 10-12 filterings, or whenever it becomes clogged with crumbs. Proceed as follows:

1. Move the COOK/PUMP switch to the OFF position.
2. Remove and empty the condensation drain pan.
3. Disconnect the filter union and remove the filter drain pan from beneath the frypot.

**3-10.  
CHANGING THE  
FILTER ENVELOPE**

**3-10.  
CHANGING THE  
FILTER ENVELOPE  
(CONT.)**

**WARNING**  
**BURN RISK**

**Use protective cloth or glove when disconnecting the filter union or severe burns could result.**

**If the filter pan is moved while full of shortening, use care to prevent splashing, or severe burns could result.**

4. Lift the filter screen assembly from the drain pan.
5. Wipe the shortening and crumbs from the filter drain pan. Clean the filter drain pan with soap and water. Thoroughly rinse with hot water.
6. Unthread the standpipe from the filter screen assembly.
7. Remove the crumb catcher and clean thoroughly with hot water.
8. Remove the filter clips and discard the filter envelope.
9. Clean the top and bottom filter screen with soap and water. Rinse thoroughly with hot water.

**CAUTION**

*Be sure that the filter screens, crumb catcher, filter clips, and the standpipe are thoroughly dry before assembly of filter envelope as water will dissolve the filter paper.*

10. Assemble the top filter screen to the bottom filter screen.
11. Slide the screens into a clean filter envelope.
12. Fold the corners in and then double-fold the open end.
13. Clamp the envelope in place with the two filter retaining clips.

**3-10.  
CHANGING THE  
FILTER ENVELOPE  
(CONT.)**

14. Replace the crumb catcher screen on top of the filter paper. Screw on the standpipe assembly.
15. Place complete filter screen assembly back into filter drain pan and slide pan back into place beneath the fryer.
16. Connect the filter union by hand. Do not use a wrench to tighten.
17. Slide the condensation drain pan back into place. The fryer is now ready to operate.

**3-11.  
LIGHTING AND  
SHUTDOWN OF THE  
BURNERS**

**TO LIGHT BURNER:**

1. Turn POWER/PUMP switch to the OFF position.
2. Rotate gas control valve knob clockwise to OFF position and wait at least five (5) minutes before continuing to next step.
3. Rotate gas control valve knob counterclockwise to ON position.
4. Place the COOK/PUMP switch to COOK position.
5. The burner will light until shortening reaches a preset temperature.
6. Press desired product button after temperature is displayed on front of control panel.

**TO SHUT DOWN BURNER:**

1. Turn POWER/PUMP switch to the OFF position.
2. Rotate gas control valve knob to the OFF position.

This fryer is equipped with a grounded (earthed) cord and plug for your protection against shock and should be plugged into a three-prong grounded (earthed) receptacle. Do not cut or remove grounding prong.

**3-12.  
CLEANING THE  
FRYPOT**

After the initial installation of the fryer, as well as before every change of shortening, the frypot should be thoroughly cleaned as follows:

1. Turn the COOK/PUMP switch to OFF, and unplug unit from wall receptacle.



**Moving the fryer or filter drain pan while containing hot shortening is not recommended. Hot shortening can splash out and severe burns could result.**

**The filter drain pan must be as far back under fryer as it will go, and the cover in place. Be sure the hole in the cover lines up with the drain before opening the drain. Failure to follow these instructions causes splashing of shortening and could result in personal injury.**

2. If hot shortening is present in the frypot, it must be drained by slowly pulling the drain handle out towards you.
3. Close the drain valve and discard the shortening.
4. Remove the racks and carrier from lid, and tilt lid back, so that the lid won't interfere with cleaning.
5. Fill the frypot to the level indicators with hot water. Add 8 to 10 ounces of fryer cleaner (Henny Penny part number 12101) to the water and mix thoroughly.



**Always wear chemical splash goggles or face shield and protective rubber gloves when cleaning the frypot as the cleaning solution is highly alkaline. Avoid splashing or other contact of the solution with your eyes or skin. Severe burns and possible blindness will result. Carefully read the instructions on the cleaner. If solution comes in contact with your eyes, rinse thoroughly with cool water and see a physician immediately.**



**CHEMICAL  
SPLASH  
GOGGLES**



**CHEMICAL  
RESISTANT  
GLOVES**

6. Turn the COOK/PUMP switch to COOK and enter the Clean-Out Mode by pressing and holding IDEL until "CLEAN OUT?", "1=YES 2=NO" shows in display. Press 1 button to start Clean-Out Mode. The fryer displays "\*CLEAN-OUT MODE\*" and heats up to a preprogrammed temperature (195°F (91°C) max.) then automatically begins a preset timed countdown. Use ▼▲, if necessary, to adjust the temperature and to keep cleaning solution from boiling over.

**3-12.  
CLEANING THE  
FRYPOT  
(CONT.)**

**⚠ DANGER**  
**BURN RISK**

**DO NOT CLOSE LID WITH WATER AND/OR CLEANER IN FRYPOT. WATER UNDER PRESSURE BECOMES SUPERHEATED. WHEN LID IS OPENED, ESCAPING WATER AND STEAM WILL RESULT IN SEVERE BURNS.**

**CAUTION**

*Watch the cleaning solution constantly to make sure it does not boil over causing damage to controls.*

*Do not use steel wool, other abrasive cleaners, or cleaners/sanitizers containing chlorine, bromine, iodine, or ammonia chemicals, as these will deteriorate the stainless steel material and shorten the life of the unit.*

*Do not spray the unit with water, such as with a garden hose. Failure to follow this caution could cause component failure.*

**⚠ WARNING**  
**BURN RISK**

**If the cleaning solution in the frypot starts to foam and boil over, immediately turn the power switch to OFF and do not try to contain it by closing the fryer lid or severe burns could result.**

7. Using the fryer brush (Henny Penny part number 12105) scrub the inside of the frypot, the lid liner, and around the countertop of the fryer.
8. After cleaning, turn off the COOK/PUMP switch. Open the drain valve and drain the cleaning solution from the frypot into the filter drain pan and discard.
9. Close the drain valve and refill the frypot with plain hot water to upper level indicator lines.
10. Add approximately 16 ounces of distilled vinegar and enter the Clean-Out Mode again (see step 5).

**3-12.  
CLEANING THE  
FRYPOT  
(CONT.)**

11. Using a clean brush, scrub the interior of the frypot and lid liner. This will neutralize the alkaline left by the cleaning compound.
12. Drain the vinegar rinse water and discard.
13. Rinse down the frypot, using clean hot water.
14. Thoroughly dry the filter drain pan, and the frypot interior.

**NOTICE**

Make sure the inside of the frypot, the drain valve opening, and all parts that come in contact with the new shortening are as dry as possible.

15. Replace the clean filter assembly in the filter drain pan and install under fryer.
16. Refill the fryer with fresh shortening.

The filter pump motor is equipped with a manual reset button, located on the rear of the motor, in case the motor overheats. Wait approximately 5 minutes before attempting to reset this protective device to allow motor to cool. Remove the access panel on the left side panel of the unit to reset the button. It takes some effort to reset, and a screwdriver can be used to help reset the button.

**3-13.  
FILTER PUMP  
MOTOR  
PROTECTOR-  
MANUAL RESET**



**To prevent burns caused by splashing shortening, turn the unit's main power switch to the OFF position before resetting the filter pump motor's manual reset protection device.**

**3-14.  
REGULAR  
MAINTENANCE  
SCHEDULE**

As in all food service equipment, the Henny Penny Pressure Fryer does require care and proper maintenance. The table below provides a summary of scheduled maintenance. The following paragraphs provide preventive maintenance procedures to be performed by the operator.

<b>Procedure</b>	<b>Frequency</b>
Filtering of shortening	Twice a day
Changing of shortening	As required
Changing the filter envelope	As required
Cleaning the deadweight assy.	Daily
Cleaning the frypot	As required
Cleaning the Nylatrons	Monthly
Reversing lid gasket	Every 90 Days
Cleaning blower	Annually-See Technical Manual
Lubricate rear lid rollers	Annually-See Technical Manual
Cleaning safety relief valve	Annually
Checking/cleaning dilution box	Annually
Inspect Counter-weight cable	Annually-see Preventive Maint.

**3-15.  
PREVENTIVE  
MAINTENANCE**



Before servicing the fryer:

- Gas supply should be turned off to avoid fire or explosion.
- Electrical supply should be unplugged or wall circuit breaker turned off to avoid electrical shock.

**CLEANING DEADWEIGHT ASSEMBLY - DAILY**



**DO NOT ATTEMPT TO REMOVE  
DEADWEIGHT CAP WHILE FRYER IS  
OPERATING. SEVERE BURNS OR OTHER  
INJURIES WILL RESULT.**

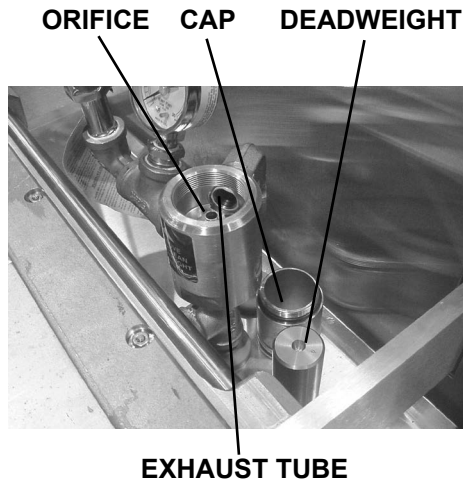

1. At the end of each day's usage of the fryer, the deadweight assembly must be cleaned. The fryer must be off and the pressure released. Open the lid and then remove the deadweight valve cap and deadweight.



**Deadweight cap may be hot. Use protective cloth or glove, or burns could result.**

**Failure to clean the deadweight assembly daily could result in the fryer building too much pressure. Severe injuries and burns could result.**

2. Wipe both the deadweight cap and weight with a soft cloth. Make certain to thoroughly clean inside deadweight cap, the weight seat, and around deadweight orifice.
3. Clean the exhaust tube with stainless steel brush (Henny Penny part number 12147).
4. Dry the parts and replace them immediately to prevent damage or loss.

**3-15.  
PREVENTIVE  
MAINTENANCE  
(CONT.)**



**Cleaning Nylatrons - Monthly**

1. Spray Henny Penny biodegradable, food safe, foaming degreaser (part no. 12226) on Nylatrons.
2. Raise lid up and down several times to spread the degreaser.
3. Wipe Nylatrons to remove food soil, grease, and degreaser residue.

**REVERSING LID GASKET - EVERY 90 DAYS**

Reversing the lid gasket helps to prevent early failure of the lid gasket and the loss of pressure during a cook cycle.

1. Raise the lid and remove the racks and carrier.
2. Grasping the lid handle, lift the front of the lid up until it stops in an upright position.



**WARNING**

Be sure the metal arm on the left side of the lid is in the vertical position holding the lid upright, or severe injuries could result. (See photo at left.)

3. Using a thin blade screwdriver, pry out the gasket at the corners. Remove the gasket.

**NOTICE**

Check the gasket for any tears or nicks. If the gasket is damaged, it needs to be replaced.

4. Clean the gasket and gasket seat with hot water.
5. Rotate the gasket with the opposite side facing out.

**NOTICE**

Install the four corners of the lid gasket. Smooth the gasket into place, working from the corners towards the middle of each side.

**3-15.  
PREVENTIVE  
MAINTENANCE  
(CONT.)**

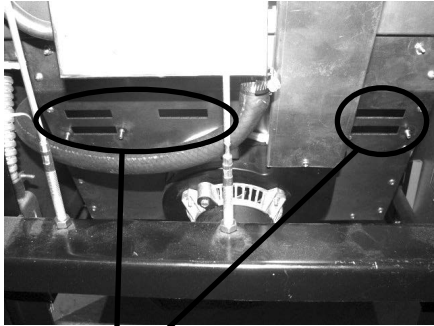

**DILUTION  
SLOTS**

**SAFETY RELIEF VALVE**



**NOTICE**

Turn the safety relief valve towards the rear of the fryer when reinstalling the relief valve.

**CHECKING/CLEANING DILUTION BOX - ANNUALLY**  
Cleaning the dilution box helps to ensure the unit operates efficiently and with few failures.

1. Make sure unit is off, and close and lock the lid.



**Lid should be in locked down position. Failure to do so could result in personal injury.**

2. Remove the back shroud of the fryer.
3. Clean the dilution box with a cloth or brush. Make sure the slots are free of debris. Replace the back shroud when finished.



Depending on the breaching location and conditions within the kitchen area, the dilution slots may need to be cleaned more often.



**DO NOT ATTEMPT TO REMOVE THE SAFETY VALVE WHILE FRYER IS OPERATING, OR SEVERE BURNS OR OTHER INJURIES WILL RESULT.**

**DO NOT DISASSEMBLE OR MODIFY THIS SAFETY VALVE. TAMPERING WITH THIS VALVE COULD CAUSE SERIOUS INJURIES AND WILL VOID AGENCY APPROVALS AND APPLIANCE WARRANTY.**

**CLEANING SAFETY RELIEF VALVE - ANNUALLY**

1. Use a wrench to remove pressure gauge.
2. Use a wrench to loosen the valve from the pipe tee; turn counterclockwise to remove.
3. Clean the inside of the pipe tee with hot water.
4. Immerse the safety relief valve in a soapy water solution for 24 hours. Use a 1:1 dilution rate. The valve cannot be disassembled. It is factory preset to open at 14-1/2 pounds of pressure. If it does not open or close, it must be replaced.

**3-15.  
PREVENTIVE  
MAINTENANCE  
(CONT.)**



Figure 1



Figure 2

**INSPECT COUNTER-WEIGHT CABLES-ANNUALLY**

Henny Penny 8 head fryers use two cables in the counter-weight mechanism that helps in the raising and lowering of the lid. Cables should be visually inspected yearly, either as part of a planned maintenance program or during a routine service call. Cables more than 10 years old should be replaced regardless of inspection results.

**NOTICE**

If lid becomes difficult to operate, stop using the fryer and call for service. Cables need replaced.

1. Using a Phillip's-head screwdriver, remove top screw, but just loosen the lower screw on each side of the fryer, shown in Figure 1.
2. Lift out on the top of the rear cover and then lift up on it to clear loosen screw, circled in Figure 2.

**3-15.  
PREVENTIVE  
MAINTENANCE  
(CONT.)**

3. Inspect the counter-weight cables. If cables have cracks in the jacket, missing pieces in the jacket, or other obvious signs of wear, call for service to have both cables replaced.

**NOT OK - REPLACE**  
**Cracks in jacket and obvious signs of wear.**

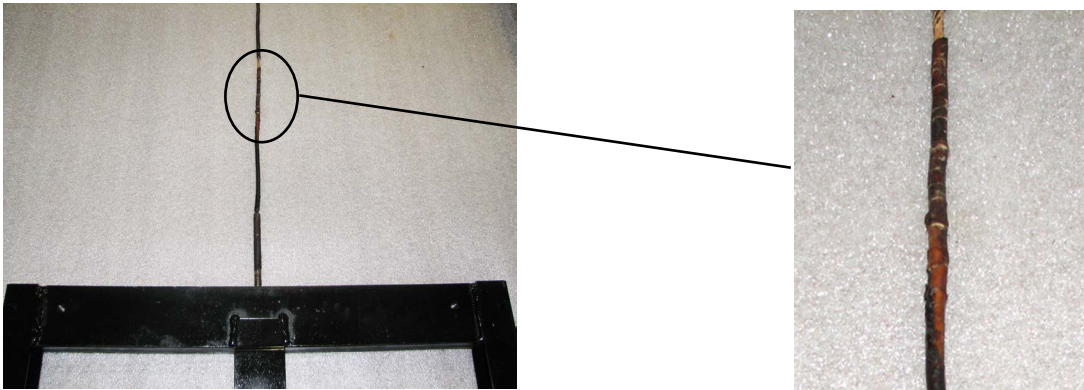

**OK**  
**No signs of cracking or wear.**

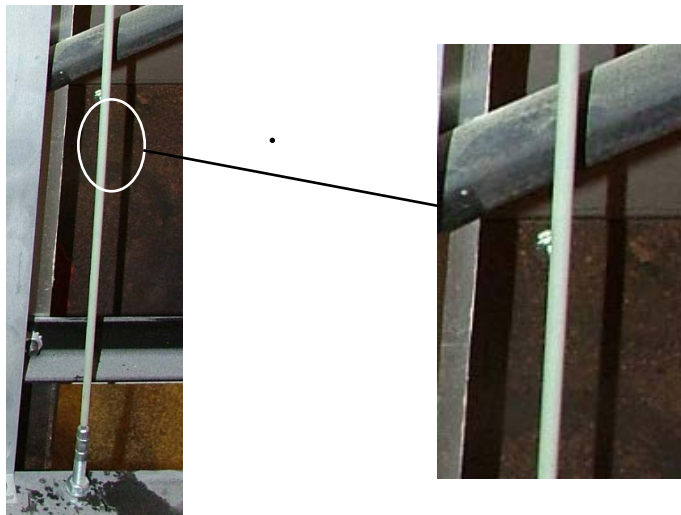

**3-16.  
PROGRAMMING**

1. Press and hold (PROG▶) for 1 second until “PROG” shows in the display, followed by “ENTER CODE”.
2. Enter code 1, 2, 3. “SELECT PRODUCT...PRESS PROG” scrolls across the display.
3. Press and release the desired product button (1 to 10).

**NOTICE**

Press ▼ to copy a product, erase a product, preset a product, erase all products, or preset all products. See Copy/Erase Preset Products section.

4. Press and release (PROG▶). The name of that product shows in the display. Ex., “NAME FRIES”.

**CHANGE PRODUCT NAMES**

- a. Press and release ▼▲ and the first letter, or digit, starts flashing.
  - b. Press and release ▼▲ to change the flashing letter.
  - c. To continue to the next letter, press (PROG▶). Then press ▼▲ to change this letter.
  - d. Repeat step c. until up to 7 letters are entered.
  - e. Press and hold (PROG▶) to exit Program Mode, or press and release (PROG▶) until “PRELOAD” shows in display to continue with Program Mode.
5. The Preload Mode allows the operator to drop large pieces first, with the lid up, before loading the rest of the product. The preload cycle always runs without pressure, which always regulates to the Step 1 cook temperature. Press ▼▲ to set a preload time, or press (PROG▶) if no preload is desired.
  6. Press and release (PROG▶) and “1. COOK TIME” shows in the display along with the preset time. Press ▼▲ to change the time. The time shows in minutes and seconds. Press and hold the buttons, and the time will jump by 5-second increments to a maximum of 59:59.

**3-16.  
PROGRAMMING  
(CONT.)**

7. Press and release (PROG▶) and “1. TEMP” shows in the display, along with the preset temperature on the right side of the display. Press ▼▲ to change the temperature.

Press and hold the buttons and the temperature will jump by 5-degree increments to a max. of 380°F (193°C), and a min. of 190°F (88°C).

8. Press and release (PROG▶) and “1. PRESSURE” shows in the display along with “YES” or “NO”. Press ▼▲ to build pressure in the first step, or not.
9. Press and release (PROG▶) and “2. STEP 2 AT” shows in display, along with a step 2 time. If no step 2 is desired, set time to “0:00” and press (PROG▶). If a step 2 is desired, press ▼▲ and set a time. Then, press (PROG▶) to set temperature and pressure.

**NOTICE**

Up to 10 steps can be programmed for a product, repeating the above step for each cooking step.

10. Press and release (PROG▶) and “ALARM – 1 AT 0:00” shows in the display. Press and release ▼▲ to set an alarm.

Ex., If a Cook Cycle was set at 3 minutes, and an alarm was to go off after 30 seconds into the Cook Cycle, “2:30” would be set in the display at this time. When the timer counts down to 2:30 the alarm sounds.

After the alarm time is set, press (PROG▶) and “ALARM” and “TYPE” flashes in the display, with the alarm type on the right side of the display. “TIME”, “SHAKE”, “STIR”, “ADD”, and “LID” can be set by pressing ▼▲.

An alarm sounds and alarm type flashes, prompting the operator to shake the basket, stir the product, or add product. If “TIME” is selected, the time remaining flashes in the display. If “LID” is selected, “CLOSE LID” flashes in the display. The timer countdown is paused until the lid is closed and timer button is pressed to restart the timer.

**NOTICE**

Up to four alarms can be programmed. After the first one is set, the other alarms can be accessed by pressing (PROG▶) again.

**3-16.  
PROGRAMMING  
(CONT.)**

11. Press and release (PROG▶) until “QUALITY TMR” shows in the display along with the preset holding time. Press and release ▼▲ to adjust the holding time, up to 59:59.

**NOTICE**

To exit the Program Mode at any time, press and hold (PROG▶) for 2 seconds.

12. Press and release (PROG▶) and “LOAD COMP” shows in the display along with the load compensation value. This automatically adjusts the time to account for the size and temperature of the cooking load. Press and release ▼▲ to change this value to a max. of 20 and a min. of 0 or “OFF”. Preset at factory at 5.
13. Press and release (PROG▶) and “LCOMP REF” shows in the display (if load compensation is set to “OFF”, then “\_ \_ \_” shows in display) along with the load compensation average temperature. This is your average cooking temperature for the products you cook. The timer speeds up at temperature above this setting and slows down at temperatures below this setting. Press and release ▼▲ to change this value.  
Or, to use the cooking setpoint temperature as the load compensation reference point, press ▲ until “STEP-X” and “TEMP” flashes in the display. Now for example, if the cooking temperature is 350°, the timer speeds up when the shortening temperature is above 350, and slows down when the temperature is below 350.

**3-16.  
PROGRAMMING  
(CONT.)**

**14. GO TO IDLE AFTER DONE?**

Press and release (PROG▶) and “GO TO IDLE, AFTER DONE” shows in the display, along with “YES” or “NO”. Press ▼▲ to toggle between YES and NO.

**15. FILTER CYCLE MODE (OPTIONAL)**

For “FILTER AFTER” to appear in the Product Program Mode, the Filter Tracking must be enabled in the Special Program Mode. You have the option to program “mixed” (each product has its own filter count) or “global” (all products have the same count).

Press (PROG▶).

**“2,MIXED”**

- a. “FILTER AFTER” shows in the display, along with the preset number of Cook Cycles.
- b. Press and release ▼▲ until the desired number of Cook Cycles between filters shows in the display. For example, if 4 is set for a product, each time that product is selected, it counts 1/4, or 25%. Then, each time a product is cooked, the percentages add up until 100%, or more is reached. Then, display shows “FILTER SUGGESTED”.

**“3,GLOBAL”**

- a. “FILTER INCL” shows in the display, along with “NO” or “YES”.
- b. Press and release ▼▲ to “YES” if that product is to be included in the filter count, or “NO” if it is not.

**3-16.  
PROGRAMMING  
(CONT.)**

**COPY/ERASE PRESET PRODUCTS**

Products and their setpoints can be copied from one menu location on the controller to another location, preset the controls to factory settings, or erase products and all their values.

1. Press and hold (PROG▶) for one second until “PROG” shows in the display, followed by “ENTER CODE”.
2. Enter code 1, 2, 3. “SELECT PRODUCT...PRESS PROG” scrolls across the display, followed by “DOWN FOR OPTIONS”.
3. Press ▼ and “\*\*OPTION\*\*”, followed by “\*1. COPY A PROD” shows in display. Press ▼ again, each time, to view the following options:
  - \*1.COPY A PROD
  - \*2.ERASE A PROD
  - \*3.PRESET A PROD
  - \*4.ERASE ALL
  - \*5.PRESET ALL
4. To select one of the above options, press (PROG▶) while the desired option shows in display.

Selecting PRESET A PROD or PRESET ALL PROD sets factory setpoints in those menu items. The following are examples of copying and erasing products:

**NOTICE**

Press (◀INFO) at any time to exit the Options menu, or wait 30 seconds and controller automatically exits.

**COPYING**

Press (PROG▶) to select the presently displayed “COPY A PROD” option. “COPY \_\_ TO \_\_” shows in display. The first set of “\_” is blinking. Select the product you wish to copy from. For example, by pressing the 2 button, “COPY 2 TO \_\_” shows in display.

**3-16.  
PROGRAMMING  
(CONT.)**

Next, press product you want to copy to. For example, by pressing 0 button, the controller responds with a confirmation message:

“COPY 2 TO 0?”  
“1=YES 2=NO”

Press 1 button (YES) and the controller copies product #2 to the product #0 position (the #2 product is left intact) and the display shows “\* COPIED \*”, then returns to the “Select Prog Product” step with the #0 product already selected.

Press 2 button (NO), or don’t press any button for 20 seconds. The controller displays “X CANCELED X” and exits the copy process. In this case, no changes are made.

**ERASING**

On the “Select Prog Product” step, press ▼ “\*\* OPTIONS \*\*” followed by “\*1. COPY A PROD” shows in display.

Press ▼ three more times to reach the “Erase All” option:  
“\*2. ERASE A PROD” (erases a single product)  
“\*3. PRESET A PROD” (sets factory settings)  
“\*4. ERASE ALL”

Press (PROG▶) to select the presently displayed “Erase All” option. The controller responds with a confirmation message:

“ERASE ALL PROD ?”  
“1=YES 2=NO”

Press 1 button (YES) to confirm that you want to erase all products back to “empty” values. The controller responds by erasing each product individually....

“ERASING 1”	“ERASING 6”
“ERASING 2”	“ERASING 7”
“ERASING 3”	“ERASING 8”
“ERASING 4”	“ERASING 9”
“ERASING 5”	“ERASING 0”

then, briefly displays “\* ALL ERASED \*” and finally, returns to the “Select Prog Product” display.

**3-17.  
SPECIAL PROGRAM  
MODE**

The Special Program Mode is used to set more detailed parameters listed below.

- SP-1 · Degrees Fahrenheit or Celsius
- SP-2 · Language: English, French, German, Spanish, and Portuguese
- SP-3 · System initialization
- SP-4 · Audio volume
- SP-5 · Audio tone
- SP-6 · Type of shortening to be melted - liquid, solid
- SP-7 · Idle Mode
- SP-8 · Filter tracking
- SP-9 · Product buttons
- SP-10 · Clean-out minutes
- SP-11 · Clean-out temperature
- SP-12 · Nominal amps reading
- SP-13 · Amps reading low limit (percentage)
- SP-14 · Amps reading high limit (percentage)
- SP-15 · Program code change
- SP-16 · Usage code change
- SP-17 · Change shortening - A-Cook Cycles
- SP-18 · Change shortening - B-Hours

**NOTICE**

If a bad code is entered, an alarm sounds and “BAD CODE” shows on the display. Wait a few seconds, the control reverts back to the Cook Mode, and repeat the above steps.

1. Press and hold (PROG▶) for 5 seconds until “L-2” and “LEVEL 2”, followed by, “SP PROG” and “ENTER CODE” show in the display.
2. Enter code 1, 2, 3, and “SP- 1 “, “TEMP, UNITS” show in the display.

To exit from the Special Program Mode at any time, press and hold (PROG▶) button for 2 seconds, or to roll back to previous

setting, press (◀INFO).

**DEGREES FAHRENHEIT OR CELSIUS (SP-1)**

- a. Follow steps 1 and 2 above.
- b. The display flashes “SP- 1” and “TEMP, UNITS”, along with “°F” or “°C”. Press ▼▲ buttons to toggle from “°F” to “°C”, or vice versa.

**3-17.  
SPECIAL PROGRAM  
MODE  
(CONT.)**

**LANGUAGE (SP-2)**

- a. Follow steps 1 and 2 above.
- b. Press and release (PROG▶) button. “SP-2” and “LANGUAGE” flash on the display, along with the language (Ex., “1.ENGL”).
- c. To toggle to the desired language, press and release ▼▲.

**SYSTEM INITIALIZATION (SP-3)**

This step resets the controls, but doesn't erase product settings.

- a. Follow steps 1 and 2 above.
- b. Press and release (PROG▶) twice. “SP-3” and “DO SYSTEM INIT” flash on the display, along with “INIT”.
- c. Press and hold ▼. “INIT” shows on the display, a tone sounds, and “IN 3”, “IN 2”, “IN 1” flash on the right side of the display. When “INIT” starts flashing on the left side of the display, release ▼. When “DONE” shows on the display, the initialization is complete, and the controls now have factory preset parameters.

**AUDIO VOLUME (SP-4)**

The volume of the speaker can be adjusted.

- a. Follow steps 1 and 2 above.
- b. Press (PROG▶) 3 times. “SP-4” and “AUDIO VOLUME” flash on the display, along with the volume value.
- c. Press ▼▲ to adjust the speaker volume; 10 the maximum value and 1 the minimum.

**AUDIO TONE (SP-5)**

The tone of the speaker can be adjusted.

- a. Follow steps 1 and 2 above.
- b. Press (PROG▶) 4 times. “SP-5” and “AUDIO TONE (HZ)” flash on the display, along with the tone value.
- c. Press ▼▲ to adjust the tone of the speaker; 2000 the maximum, 50 the minimum.

**3-17.  
SPECIAL PROGRAM  
MODE  
(CONT.)**

**TYPE OF SHORTENING TO BE MELTED - LIQUID OR SOLID (SP-6)**

The Melt Cycle can be set to the type of shortening being used.

- a. Follow steps 1 and 2 above.
- b. Press and release (PROG▶) 5 times. “SP-6” and “MELT CYCLE SELECT” flash on the display, along with “1=LIQ” or “2=SOLID”.
- c. Press ▼▲ to toggle from one type to another.

**CAUTION**

*The type of shortening being used in the cooker determines the amount of heat applied during the Melt Cycle. If the controls are set to the solid setting, less heat is applied to the shortening, than if the controls were set to liquid. Too much heat applied to solid shortening causes much smoking, and could cause a fire. Match this setting to the type of shortening being used at the time.*

*When using solid shortening, it is recommended to melt the shortening on an outside source before placing shortening in the frypot. Unless elements are completely covered in shortening, fire or damage to the frypot could result.*

**IDLE MODE (SP-7)**

A programmed Idle Mode allows the shortening temperature to drop to a lower temperature when not in use. This saves on the shortening and utilities.

- a. Follow steps 1 and 2 above.
- b. Press and release (PROG▶) 6 times. “SP-7” and “IDLE MODE ENABLED?” flash in the display, along with “NO” or “YES”.
- c. Press and release ▼▲ to toggle from NO to YES, or vice versa.
- d. With “YES” in the display, the Idle Mode is enabled. Press and release (PROG▶). “SP-7A” and “IDLE SETPT TEMP” show in the display, along with the preset temperature.

**3-17.  
SPECIAL PROGRAM  
MODE  
(CONT.)**

- e. Change the idle setpoint temperature, by pressing ▼▲.
- f. Press and release (PROG▶). “SP-7B” and “AUTO-IDLE MINUTES” show in the display, along with the preset time.
- g. Press ▼▲ to set the minutes the fryer stays idle before the Auto-idle is enabled; 60 the maximum, OFF the minimum. Ex., “30” in the display means, if product is not cooked in that frypot for 30 minutes, the control automatically activates the idle setpoint temperature, programmed above.
- h. Press and release (PROG▶). “SP-7C” and “GO IDLE AT MELT EXIT?” show in display.
- i. Press ▼▲ to toggle from NO to YES, or vice versa. With “YES” in the display, the fryer automatically enters the Idle Mode once the Melt Mode is exited.

**FILTER TRACKING ENABLED (SP-8)**

The controls can be set to signal the operator when the shortening needs filtering. The Filter Tracking must be enabled to program the number of Cook Cycles between filtering procedures. (See Filter Cycles paragraph 3-16.)

- a. Follow steps 1 and 2 above.
- b. Press and release (PROG▶) until “SP-8” and “FILTER TRACKING ENABLED” flash on the display, along with “1,OFF”.
- c. To enable the filter tracking, press ▼▲ to toggle the display from “1,OFF”, to “2,MIXED”, or, “3,GLOBAL”

**NOTICE**

The Mixed setting allows the operator to set different amounts of Cook Cycles, between filters, for each product. If the operator wants to have one setting for all products go to step h.

- d. If “2,MIXED” is selected, press (PROG▶) and “SP-8A” shows in the display followed by “SUGGEST FILTER AT ...” and a value between 75% and 100%. Press and release ▼▲ to change this value.
- e. Press (PROG▶) and “SP-8B” shows in the display followed by “LOCKOUT ENABLED?” and “YES” or “NO”. Press and release ▼▲ to choose YES or NO.

**3-17.  
SPECIAL PROGRAM  
MODE  
(CONT.)**

- f. Press (PROG▶) and “SP-8C” shows in the display. “FILTER LOCKOUT AT...” and a value between 100% and 200% show in display. Press ▼▲ to change this value.
- g. Press (PROG▶) and “SP-8D” shows in the display, if YES was chosen in step e. “LOCKOUT-HEAT OIL...” and a temperature (preset at 300°F (149°C) show in display. When a filter lockout occurs, the fryer heats up to this set temperature, and the display shows “FILTER LOCKOUT/WAIT”. Then once the set temperature is reached, “FILTER LOCKOUT”/ “YOU \*MUST\* FILTER NOW” shows in display. Use ▼▲ to change this temperature setting.
- h. Now, go back to the Filter Cycle Mode step of the Programming section, and program in the number of Cook Cycles between filtering.
- i. If “3,GLOBAL” is selected, “SP-8A” shows in the display, and followed by “GLOBAL FILTER CYCLES”. The right side of the display shows a digit, 1 to 99. Press ▼▲ to set the desired amount of Cook Cycles between filters.

**NOTICE**

In Cook Mode, the number of global Cook Cycles remaining shows in the center of the display.  
Ex., “----- 5x -----”.

- j. Press (PROG▶) and “SP-8B” shows in the display followed by “LOCKOUT ENABLED?” and “YES” or “NO”. Press and release ▼▲ to choose YES or NO.
- k. Press (PROG▶) and “SP-8C” shows in the display, followed by “LOCKOUT-HEAT OIL...” and a temperature (preset at 300°F (149°C). When a filter lockout occurs, the fryer heats up to this set temperature, and the display shows “FILTER LOCKOUT/WAIT”. Then once the set temperature is reached, “FILTER LOCKOUT”/ “YOU \*MUST\* FILTER NOW” shows in display. Use ▼▲ to change this temperature setting.
- l. Now, go back to the Filter Cycle Mode step of the Programming section. Press (PROG▶) until “FILTER INCL” shows in the display. Each product must be set to “YES” to be included in the filter tracking.

**3-17.  
SPECIAL PROGRAM  
MODE  
(CONT.)**

**PRODUCT BUTTONS (SP-9)**

This mode allows you set up the way products are selected, and Cook Cycles started, in the cook mode.

- a. Follow steps 1 and 2 above.
- b. Press and release (PROG▶) until “SP-9” and “PRODUCT BUTTONS” flash in the display.
- c. When using the first option, “1,COOK”, pressing a product button displays that product and starts the Cook Cycle. When nothing is cooking, no product displays.
- d. Press ▼▲ to show the second option. If using “2,SELECT”, pressing a product button displays the product only. Press TIMER button to start the Cook Cycle.

**CLEAN-OUT MINUTES (SP-10)**

This allows you to set the number of minutes of the Clean-Out Mode.

- a. Follow steps 1 and 2 above.
- b. Press (PROG▶) until “SP-10” and “CLEAN-OUT MINUTES” show in display, along with the preset minutes.
- c. Press ▼▲ to change the number of minutes, up to 99.

**CLEAN-OUT TEMPERATURE (SP-11)**

This allows you to set the temperature of the Clean-Out Mode.

- a. Follow steps 1 and 2 above.
- b. Press (PROG▶) until “SP-11” and “CLEAN-OUT TNP” show in display, along with the set temperature.
- c. Press ▼▲ to change the temperature, up to 195°F (91°C).

**NOMINAL AMPS READING (SP-12)-NOT USED ON MODEL 691**

“SP-12”, “AMPS RDG, NOMINAL” should show on the left side of display, and “OFF” on the right side.

**AMPS READING LOW LIMIT (SP-13)-NOT USED ON MODEL 691**

“SP-13” and “AMPS RDG, LOW LIMIT” should show on the left side of display, and “OFF” on the right side.

**AMPS READING HIGH LIMIT (SP-14)-NOT USED ON MODEL 691**

“SP-14” and “AMPS RDG, HIGH LIMIT” should show on the left side of display, and “OFF” on the right side.

**3-17.  
SPECIAL PROGRAM  
MODE  
(CONT.)**

**MANAGER CODE CHANGE (SP-15)**

This allows the operator to change the program code, or manager code (factory set at 1, 2, 3) used to access Product Programming, Special Programming, Clock Set, Data Comm, and Heat Control Modes.

- a. Follow steps 1 and 2 above.
- b. Press (PROG▶) until “SP-15” and “CHANGE, MGR CODE? 1=YES” show in display, along with “CODE”.
- c. Press 1 button. “ENTER NEW CODE, P=DONE, I=QUIT” show in display. Press Product buttons with new code.
- d. If satisfied with code, press (PROG▶). “REPEAT NEW CODE, P=DONE, I=QUIT”, show in display. Press same code buttons in step c.
- e. If satisfied with code, press (PROG▶). “\*CODE CHANGE\*” shows in display.
- f. If not satisfied with code, press (◀INFO) and “\*CANCELED\*” shows in display, then reverts back to “SP-15” and “CHANGE, MGR CODE? 1=YES”. Then the above steps can be repeated.

**USAGE CODE CHANGE (SP-16)**

This allows the operator to change the usage code (factory set at 1, 2, 3) used to reset the usage data in the Information Mode.

- a. Follow steps 1 and 2 above.
- b. Press (PROG▶) until “SP-16” and “CHANGE, USG CODE? 1=YES” show in display, along with “USAGE”.
- c. Press 1 button. “ENTER NEW CODE, P=DONE, I=QUIT” show in display. Press Product buttons with new code.
- d. If satisfied with code, press (PROG▶). “REPEAT NEW CODE, P=DONE, I=QUIT”, show in display. Press same code buttons in step c.
- e. If satisfied with code, press (PROG▶). “\*CODE CHANGE\*” shows in display.
- f. If not satisfied with code, press (◀INFO) and “\*CANCELED\*” shows in display, then reverts back to “SP-16” and “CHANGE, USG CODE? 1=YES”. Then the above steps can be repeated.

**3-17.  
SPECIAL PROGRAM  
MODE  
(CONT.)**

**CHANGE SHORTENING - A-COOK CYCLES (SP-17)**

This mode allows the operator to set the number of Cook Cycles between shortening changes. When the set numbers of Cook Cycles is reached, the control displays “CHANGE OIL SOON”. This mode is just a reminder and cooking can continue.

**NOTICE**

For this feature to operate, the operator must reset the Review Usage data in the Information Mode. See Review Usage step in Information Mode section.

- a. Follow steps 1 and 2 above.
- b. Press (PROG▶) until “SP-17” and “CHANGE OIL A-COOK CYCLES” show in display, along with the number of Cook Cycles or “OFF”.
- c. Press ▼▲ to change the number of Cook Cycles (“OFF” to 5000 cycles).

**CHANGE SHORTENING - B-HOURS (SP-18)**

This mode allows the operator to set the number of power on hours between shortening changes. These hours are not only cooking time, but the total time the fryer is on. When the set numbers of hours are reached, the control displays “CHANGE OIL SOON”. This mode is just a reminder and cooking can continue.

**NOTICE**

For this feature to operate, the operator must reset the Review Usage data in the Information Mode. See Review Usage step in Information Mode Section.

- a. Follow steps 1 and 2 above.
- b. Press (PROG▶) until “SP-18” and “CHANGE OIL B-HOURS” show in display, along with the number of hours or “OFF”.
- c. Press ▼▲ to change the number of hours (“OFF” to 999 hours).

**NOTICE**

Press and hold (PROG▶) at any time to exit Special Program Mode.

The Data Logging, Heat Control, Tech, and Stat Modes are advanced diagnostic and program modes, mainly for Henny Penny use only. For more information on these Modes, contact the Service Department at 1-800-417- 8405, or 1-937-456-8405.

**3-18.  
DATA LOGGING,  
HEAT CONTROL,  
TECH, AND STAT  
MODES**

**3-19.  
INFORMATION  
MODE**

This mode gathers and stores historic information on the fryer and operator's performance. Press (PROG▶) and (◀INFO) at the same

time and “\*INFO MODE\*” shows on display. Press (PROG▶) or (◀INFO) to access the steps and press ▼ to view the statistics within each step. Information Mode is intended for technical use, but the operator can view the following information:

1. **E-LOG** - last 10 errors and time they occurred
2. **LAST LOAD** - information about the most recent Cook Cycle, or the cycle presently in progress
3. **DAILY STATS** - information for the last 7 days
4. **REVIEW USAGE**- information accumulated since the last time this data was manually reset
5. **INPA VHDSF PM.PM** - provides test of fryer inputs
6. **OUTP** - shows the state of heater and pressure
7. **OIL TMP** - temperature of shortening
8. **CPU TMP** - temperature of PC board
9. **ANALOG** - status of controller's a-to-d converter

**NOTICE**

Press and hold (PROG▶) to exit Information Mode at any time, or after 2 minutes, controls automatically exit back to normal operation.

**1. E-LOG (error code log)**

Press ▼ and “1A” (date & time) “\*NOW\*” show in display. This is the present date and time.

Press ▼ and if a error was recorded, “1B” (date, time, and error code information) shows in display. This is the latest error code that the controls recorded.

Press ▼ and the next latest error code information can be seen. Up to 10 error codes (1B to 1K) can be stored in the E-LOG Section.

Press (PROG▶) to continue to LAST LOAD.

**3-19.  
INFORMATION  
MODE  
(CONT.)**

**2. LAST LOAD**

Press ▼ to view the following information from the most recent Cook Cycle.

FUNCTION	DISPLAY EX.
Time of day the last Cook Cycle was started	STARTED 10.25A
Product (Last product cooked)	PRODUCT -2-
Ready? (Was fryer Ready before start?)	READY? YES
Stopped: Time remaining, or secs past Done	*DONE* + 9 SECS
Actual elapsed cook Time (real seconds)	ACTUAL TIME 7:38
Programmed cook Time	PROG TIME 7:00
Actual time vs. Prog time (Percentage)	ACT / PROG 109%
Max Temp during Cook Cycle	MAX TEMP 327°F
Min Temp during Cook Cycle	MIN TEMP 313°F
Avg Temp during Cook Cycle	AVG TEMP 322°F
Heat On (percentage) during Cook Cycle	HEAT ON 73%
<i>Only if Presently Cooking:</i>	
Present cook step, setpoint, and time rem.	STEP 1:325°F 6:47
Actual shortening temp., deg below load comp avg, present stretch time (real secs/ck sec)	313°F LC-12° 1.06

Press (PROG▶) to continue to DAILY STATS.

**3. DAILY STATS** (reset each day)

Press ▼ to view the following operation information for any of the last 7 days. Press IDLE button to select which day.

FUNCTION	DISPLAY EX.
Day this data was recorded for	TUE* APR-30
Number of Hours:Minutes the fryer was on	TUE* ON HRS 13:45
Number of times shortening was filtered that day	TUE* FILTERED 3
Total number of Cook Cycles that day	TUE* TOTAL CK 38
Cook Cycles for product #1	TUE* COOK -1- 17
Cook Cycles for product #2	TUE* COOK -2- 9
Cook Cycles for product #3	TUE* COOK -3- 5
Cook Cycles for product #4	TUE* COOK -4- 0
Cook Cycles for product #5	TUE* COOK -5- 0
Cook Cycles for product #6	TUE* COOK -6- 6
Cook Cycles for product #7	TUE* COOK -7- 0
Cook Cycles for product #8	TUE* COOK -8- 0
Cook Cycles for product #9	TUE* COOK -9- 1
Cook Cycles for product #0	TUE* COOK -0- 0

Press (PROG▶) to continue to REVIEW USAGE.

**3-19.  
INFORMATION  
MODE  
(CONT.)**

**4. REVIEW USAGE**

Press ▼ to view the accumulated information since the data was manually reset:

FUNCTION	DISPLAY EX.
Day the usage data was previously reset	SINCE APR-19
Number of hours the fryer was On	PWR ON HRS 165
Number of times shortening was filtered	FILTERED 34
Total number of Cook Cycles	TOTAL CK 462
Percentage of Cook Cycles before shortening change	OIL WEAR -A- 73%
Cook Cycles for product #1	COOKED -1- 193
Cook Cycles for product #2	COOKED -2- 107
Cook Cycles for product #3	COOKED -3- 58
Cook Cycles for product #4	COOKED -4- 0
Cook Cycles for product #5	COOKED -5- 13
Cook Cycles for product #6	COOKED -6- 69
Cook Cycles for product #7	COOKED -7- 0
Cook Cycles for product #8	COOKED -8- 7
Cook Cycles for product #9	COOKED -8- 7
Cook Cycles for product #0	COOKED -0- 0
<b>Reset usage data:</b> Enter the Mgr Code (1, 2, 3 unless changed) on this step to zero out all the usage information	RESET USG/ENTER CODE----

Press (PROG▶) to continue to INP A\_CVHDSFPM PM.

**5. INP A\_CVHDSFPM.PM**

Press ▼ to view the status of components and inputs. If

the input signal is detected, an identifying letter is displayed (see below). If the signal is not detected, “\_” is displayed.

With the COOK/PUMP switch in the COOK position, and all inputs detected, “H\_P\_A\_CVHDSFPM.PM” shows in display. See below for definition of codes. See chart to the left of the page

A=	COOK/PUMP in COOK position
B=	COOK/PUMP in PUMP position
C=	Solenoid continuity; won't show with pressure on V = Volts - 24-VAC detected
V=	Volts - 24-VAC detected
H=	High Limit - If “H” is present, the high limit is good; if “H” is missing, the high limit is tripped (overheated) or faulty
D=	DRAIN SWITCH-If “D” is present, the drain handle is closed; if “D” is missing, the drain is open or faulty
S=	COOK/PUMP switch ON interlock circuit: If “S” is present, the COOK/PUMP switch is in the COOK position; if the “S” is missing, the COOK/PUMP is either off, failed, or wired incorrectly
F=	FAN
P=	PV-Detects output from PV terminal of ignition module
M=	MV-Detects output from MV terminal of ignition module

**3-19.  
INFORMATION  
MODE  
(CONT.)**

Press ▼ to view the specific status of each input. An underscore (“\_”) indicates the input is not presently detected. A checkmark (“√”) indicates the signal is detecting a normal input. A blinking (“X”) indicates the signal is presently detected, but is detected as a half-wave (partially failed) input.

**NOTICE**

The V, H, D, S, F, P and M signals are wired in series. The first signal missing out of this sequence generally causes all signals to the right of it to be missing as well.

Press ► to continue onto OUTP H\* P\_.

**6. OUTP F\*I\*H\*P\_**

This mode displays the status of components and outputs. If the output signal is detected, an identifying letter is displayed (see below), followed by an “\*”. If the output is off, “\_” is displayed.

“F” = Fan output

“I” = Ignition modules output

“H” = Heat output

“P” = Pressure output

If fan is on, “F\*” shows in display. If fan is off, “F\_” shows in display. If controls sense a problem with the fan output, “F\*” shows in display, with the “\*” flashing.

When ignition modules are on, “I\*” shows in the display. If ignition modules are off, “I\_” shows in display. If controls sense a problem with an ignition module, “I\*” shows in the display with “\*” flashing.

If heat is on, “H\*” shows in display. If heat is off, “H\_” shows in display. If controls sense a problem with the heat output, “H\*” shows in display, with the “\*” flashing.

If pressure is on, “P\*” shows in display. If pressure is off, “P\_” shows in display. If controls sense a problem with the pressure output, “P\*” shows in display, with the “\*” flashing.

Press ▼ to view the amp “DRAW” status of each output. “H√” and “P√” in the display means the amps are good. A flashing “X” behind the H or P means too much current.

**3-19.  
INFORMATION  
MODE  
(CONT.)**

Press ▼ to view the No Connect/Ground (“NC/GND”) status of each output. This monitors a possible problem with the relays on the output PC board. “H√” and “P√” in the display means everything on the output PC board is good. A flashing “X” behind the “H” or “P” means a problem exists.

Press ▼ to view the outputs and inputs together.

Press (PROG▶) and “6. PMP\_ AIR\_” shows in display.

Press ▼ to view the amp “DRAW” status of the pump motor output and air valve output. “PMP√” and “AIR√” in the display means the amps are good. A flashing “X” behind the “PMP” or “AIR” means too much current.

Press ▼ to view the No Connect/Ground (“NC/GND”) status of each output. This monitors a possible problem with the relays on the output PC board.

Press (PROG▶) to continue onto the OIL TMP reading.

#### **7. OIL TMP**

This step shows the present peanut oil temperature. The display shows “7. OIL TMP (temp.)”. Press (PROG▶) to continue onto the CPU TMP reading.

#### **8. CPU TMP**

This step shows the present PC board temperature.

Press (PROG▶) to continue onto the ANALOG reading.

#### **9. ANALOG <1> 2.86V**

This step displays the present status of any channel of the controller’s a to d converter. This feature may be useful to a technician troubleshooting a problem with the fryer or controller.

The displayed value can be toggled between volts and bits by pressing 0 button. If the displayed value has a decimal point, it is voltage (0 to 5 VDC). If no decimal point is shown, the value is a-to-d bits (0 - 4095).

### **NOTICE**

Press and hold (PROG▶) to exit Information Mode at any time, or after 2 minutes, controls automatically exit back to normal operation.

## SECTION 4: TROUBLESHOOTING

### 4-1. TROUBLESHOOTING GUIDE

Problem	Cause	Correction
Power switch on but fryer completely inoperative	<ul style="list-style-type: none"> <li>Open circuit</li> </ul>	<ul style="list-style-type: none"> <li>Plug fryer in</li> <li>Check breaker or fuse at wall</li> </ul>
Pressure not exhausting at end of Cook Cycle	<ul style="list-style-type: none"> <li>Solenoid or exhaust line clogged</li> </ul>	<ul style="list-style-type: none"> <li>Turn off and allow fryer to cool to release the pressure in frypot; have all lines, solenoid, and exhaust tank cleaned</li> </ul>
Operating pressure too high	<ul style="list-style-type: none"> <li>Deadweight clogged</li> </ul>	<ul style="list-style-type: none"> <li>Turn off and allow fryer to cool to release the pressure in frypot; clean deadweight; see Preventive Maintenance Section</li> </ul>



**DO NOT OPERATE UNIT IF PRESSURE GAUGE SHOWS HIGH PRESSURE CONDITIONS. SEVERE INJURIES AND BURNS WILL RESULT. IMMEDIATELY PLACE THE POWER/ PUMP SWITCH IN THE OFF POSITION, WHICH RELEASES THE PRESSURE BY ALLOWING THE UNIT TO COOL. DO NOT RESUME USE OF UNIT UNTIL CAUSE OF HIGH PRESSURE HAS BEEN FOUND AND CORRECTED.**

Pressure does not build	<ul style="list-style-type: none"> <li>Not enough product in frypot\</li> <li>Metal shipping spacer not removed from deadweight</li> <li>Pressure not programmed</li> <li>Lid gasket leaking</li> </ul>	<ul style="list-style-type: none"> <li>Place full capacity product in frypot when using fresh shortening</li> <li>Remove shipping spacer; see Unpacking Instructions Section</li> <li>Check programming</li> <li>Reverse or replace lid gasket</li> </ul>
Shortening not heating	<ul style="list-style-type: none"> <li>Gas valve knob turned to the OFF position</li> <li>Drain valve open</li> <li>High temperature limit tripped</li> </ul>	<ul style="list-style-type: none"> <li>Make sure gas control valve knob is turned to the ON position</li> <li>Close drain valve</li> <li>Reset high temperature limit; see Operating Components Section</li> </ul>
Foaming or boiling over	<ul style="list-style-type: none"> <li>See Boil-Over chart on fryer and information in this manual</li> </ul>	<ul style="list-style-type: none"> <li>Follow Boil-Over procedures from chart</li> </ul>
Shortening not draining	<ul style="list-style-type: none"> <li>Drain valve clogged</li> </ul>	<ul style="list-style-type: none"> <li>Push cleaning rod through open drain valve</li> </ul>
Filter motor won't run	<ul style="list-style-type: none"> <li>Motor overheated</li> </ul>	<ul style="list-style-type: none"> <li>Reset motor; see Filter Pump Motor Protector-Manual Reset Section</li> </ul>



More detailed troubleshooting information is available in the Technical Manual, available at [www.hennypenny.com](http://www.hennypenny.com), or 1-800-417-8405 or 1-937-456-8405.

**4-2.  
ERROR CODES**

In the event of a control system failure, the digital display shows an error message. These messages are coded: “E-4”, “E-5”, “E-6”, “E-32”, “E-41” and “E-71”. A constant tone is heard when an error code is displayed, and to silence this tone, press any of the product buttons.

<b>Display</b>	<b>Cause</b>	<b>Panel Board Correction</b>
“E-4”	Control board overheating	Turn switch to OFF position, then turn switch back to ON; if display still shows “E-4”, the board is getting too hot; check for signs of overheating behind the control panel; once panel cools down the controls should return to normal; if “E-4” persists, have control panel replaced
“E-5”	Shortening overheating	Turn switch to OFF position, then back to ON; if display shows “E-5”, the heating circuits and temperature probe should be checked; once the unit cools down, the controls should return to normal; if “E-5” persists, have control panel replaced
“E-6”	Temperature probe failure	Turn switch to OFF position, then back to ON; if the display shows “E-6”, the temperature probe should be checked; once the probe is repaired, or replaced, the controls should return to normal; if “E-6” persists, have control panel replaced
“E-41”	Programming failure	Turn switch to OFF position, then back to ON; if display shows “E-41”, the control should be re-initialized (See Programming Section) if the error code persists, have control panel replaced
“E-71”	Pump motor relay failure or wiring problem	Pump motor relay failure or Replace relay if contacts are stuck closed; check wiring on POWER/PUMP switch, or at wall receptacle; L1 and N may be reversed
“E32, FAN FAIL ERROR, CHECK BLOWER, CLEAN DILUTIONBOX, CALL HENNY PENNY SERVICE”	Air pressure switch open; clogged dilution box or faulty blower; open drain switch; open high limit	Clean dilution box or replace blower if necessary; have drain switch checked; reset high limit or have high limit checked

**4-2.  
ERROR CODES**

**CE Only - Along with the error codes from page 4-2, CE units have the following self-diagnostic error codes:**

<b>Display</b>	<b>Cause</b>	<b>Panel Board Correction</b>
“E-10”	High limit	Reset the high limit by manually pushing up on the red reset button; if the high limit does not reset, the high limit must be replaced
“E-15”	Drain switch	Close the drain, using the drain valve handle; if display still shows “E-15”, have the drain microswitch checked
“E-20A”	Air pressure switch failure	Press the timer button to try the ignition process again, and if “E-20A” persists, call Henny Penny’s Service (stuck closed) Department
“E-20B”	Draft fan or air pressure switch failure (stuck open)	Press the timer button to try the ignition process again, and if “E-20B” persists, call Henny Penny’s Service Department
“E-20C”	Left gas module failure	Press the timer button to try the ignition process again, and if “E-20C” persists, call Henny Penny’s Service Department
“E-20D”	Right module failure	Press the timer button to try the ignition process again, and if “E-20D” persists, call Henny Penny’s Service Department
“E-20E”	Both modules failure	Press the timer button to try the ignition process again, and if “E-20E” persists, call Henny Penny’s Service Department
“E-20F”	Left module no flame sense	Press the timer button to try the ignition process again, and if “E-20F” persists, call Henny Penny’s Service Department
“E-20G”	Right module no flame sense	Press the timer button to try the ignition process again, and if “E-20G” persists, call Henny Penny’s Service Department
“E-20H”	Both modules no flame sense	Press the timer button to try the ignition process again, and if “E-20H” persists, call Henny Penny’s Service Department



**Henny Penny Corporation**  
**P.O.Box 60**  
**Eaton, OH 45320**

**1-937-456-8400**  
**1-937-456-8402 Fax**

**Toll free in USA**  
**1-800-417-8417**  
**1-800-417-8434 Fax**

**[www.hennypenny.com](http://www.hennypenny.com)**

\*FM05-010-K\* Henny Penny Corp., Eaton, Ohio 45320, Revised 7-1-13