



TECHNICAL M A N U A L

VELOCITY SERIES™ PRESSURE FRYER

MODEL

PXE-100



HENNY PENNY
Engineered to Last

REGISTER WARRANTY ONLINE AT WWW.HENNYPENNY.COM

HENNY PENNY ELECTRIC PRESSURE FRYER

SPECIFICATIONS

Pot Capacity	8 head of chicken - 24 lbs. (10.8 kg) 76 lbs. oil (34 Kg.)
Electrical	208 VAC, 3 Phase, 50/60 Hz, 17 KW, 47.2 Amps 240 VAC, 3 Phase, 50/60 Hz, 17 KW, 40.9 Amps 480 VAC, 3 Phase, 50/60 Hz, 17 KW, 20.5 Amps
Heating	Two 8,500 watt electric immersion elements

NOTICE

A data plate, located on the back shroud behind the lid identifies the fryer model, serial number, warranty date, and other information. Also, the serial number is stamped on the outside of the counter top. See figure below.

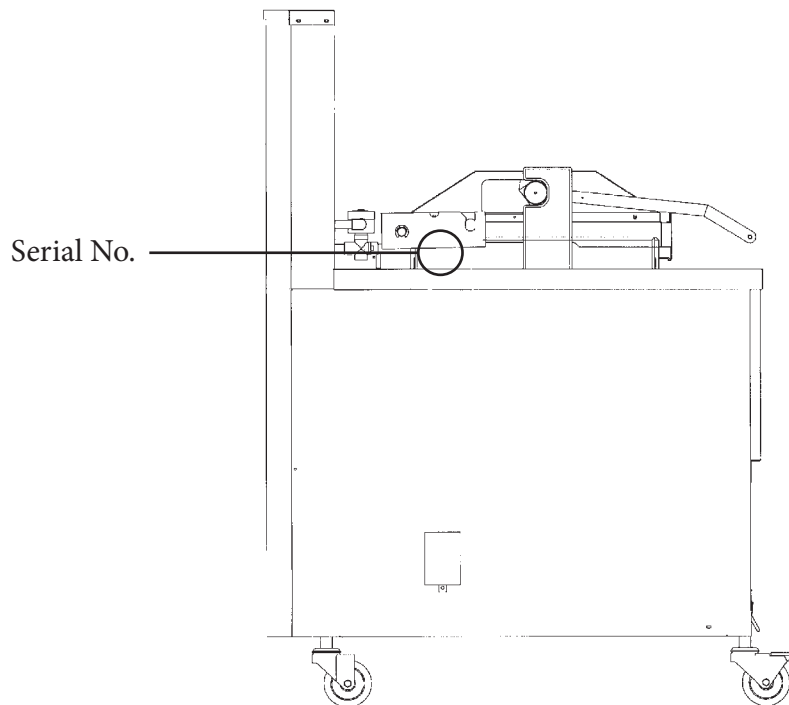

**PXE-100
DIMENSIONS**

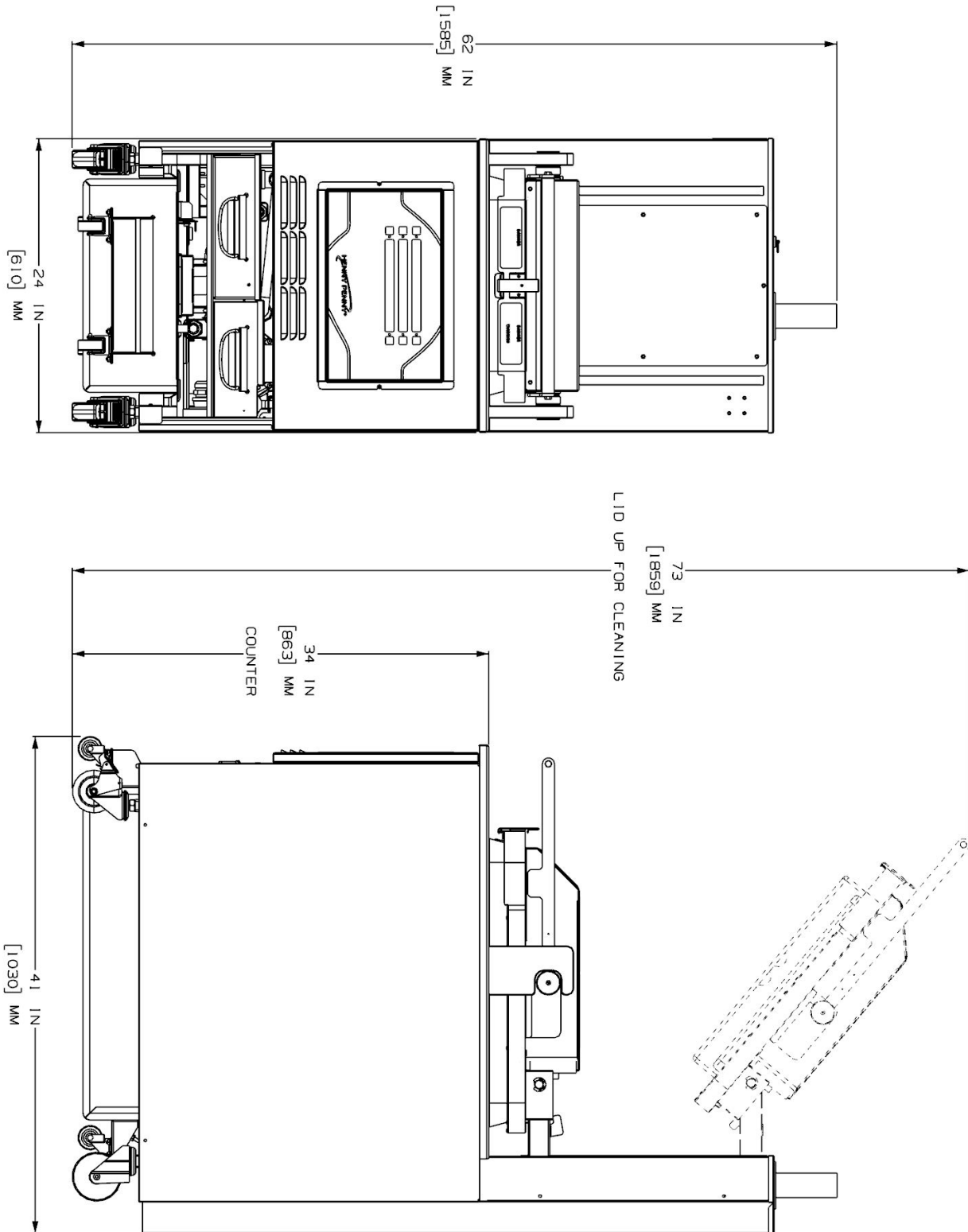

**OPERATING
COMPONENTS**



Item No.	Description	Function
1	Steam-Stack	Houses the dead-weight. Releases steam when pressurized
2	Fresh Oil Tank	Tops the vat off with fresh oil when low
3	Power Switch	Turns power to the unit ON/ OFF
4	Condensation Pan	Reservoir that hold excess condensation that drains from the vat
5	Oil Drain Pan	Oil is drained into this pan and then is pumped through filters to help prolong the use of the oil

**CONTROL
OVERVIEW**

This section gives a control board overview and explains all the buttons, displays and features.



Figure 3-1

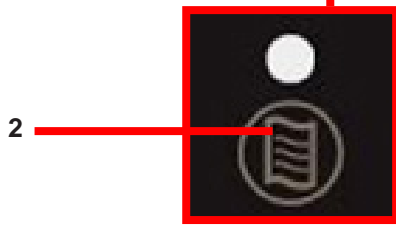

Figure 3-2

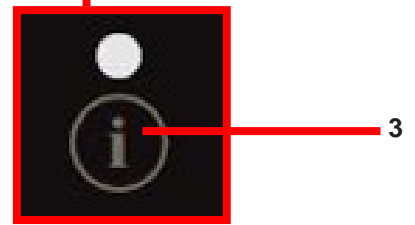

Figure 3-3

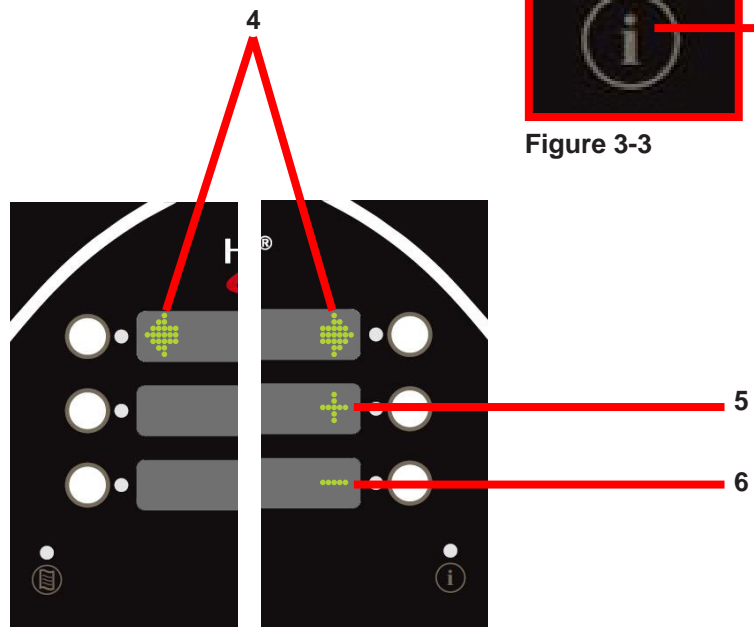

Figure 3-4

**CONTROL
OVERVIEW
(CONT.)**

Fig.	Item No.	Description	Function
3-1	1	Buttons	When the light is illuminated next to the button, this indicates this button has a product or action that can be reached by pressing.
3-2	2	Menu Button	Pressing and holding this button will access the “MAIN” menu which includes features such as filter, info mode, and programming.
3-3	3	Info Button	<ul style="list-style-type: none"> • Press this button once to display the pressure and temperature • Press this button twice to activate the “WIPE” feature • Press this button three times to get “LAST FILTER” information
3-4	4	Arrow Displays	When an arrow is displayed, this indicates there is another screen or option. To access the next option/screen, press the button next to the desired arrow.
3-4	5	Plus Display	<p>The plus sign is displayed when the value of the time/temp/letters can be changed. Pressing the button next to the plus sign will increase the value.</p> <p>Will be represented in the manual by: +</p>
3-4	6	Minus Display	<p>The minus sign is displayed when the value of the time/temp/letters can be changed. Pressing the button next to the minus sign will decrease the value.</p> <p>Will be represented in the manual by: -</p>

**HENNY PENNY
8 HEAD ELECTRIC PRESSURE FRYER**



Fryer must be installed and used in such a way to prevent water from contacting the shortening.



This appliance is not intended to be operated by means of an external timer or a separate remote control system.



This appliance is not intended for use by persons (including children) with reduced physical, sensory or mental capabilities, or lack of experience and knowledge, unless they have been given supervision or instruction concerning use of the appliance by a person responsible for their safety.

SECTION 1: INTRODUCTION

1-1 SAFETY

The instructions in this manual have been prepared to aid you in learning the proper procedures for your equipment. Where information is of particular importance or is safety related, the words NOTICE, CAUTION, or WARNING are used. Their usage is described below.

If a problem occurs during the first operation of a new unit, recheck the Installation Section of the Operator’s Manual.

Before troubleshooting, always recheck the Operation Section of the Operator’s Manual.

Where information is of particular importance or is safety related, the words DANGER, WARNING, CAUTION, or NOTICE are used. Their usage is described as follows:



SAFETY ALERT SYMBOL is used with DANGER, WARNING or CAUTION which indicates a personal injury type hazard.



NOTICE is used to highlight especially important information.



CAUTION used without the safety alert symbol indicates a potentially hazardous situation which, if not avoided, may result in property damage.



CAUTION used with the safety alert symbol indicates a potentially hazardous situation which, if not avoided, could result in minor or moderate injury.



WARNING indicates a potentially hazardous situation which, if not avoided, could result in death or serious injury.



DANGER INDICATES AN IMMINENTLY HAZARDOUS SITUATION WHICH, IF NOT AVOIDED, WILL RESULT IN DEATH OR SERIOUS INJURY.

**1-1.
SAFETY
(CONT.)**



Equipotential Ground Symbol



Waste Electrical and Electronic Equipment (WEEE) Symbol

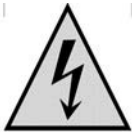

OR



Shock Hazard Symbols



OR



Hot Surface Symbols

**1-2.
PROPER CARE**

As in all Henny Penny equipment, the unit requires care and maintenance. Requirements for maintenance and cleaning are contained in this manual and must be a regular part of the operation of the unit.

**1-3.
ASSISTANCE**

Should you require outside assistance, call your local distributor in your area, or call 1-800-417-8405 or 1-937-456-8405 for Henny Penny Technical Support.

SECTION 2: TROUBLESHOOTING

2-1. TROUBLESHOOTING GUIDE

PROBLEM	CAUSE	CORRECTION
Power switch on but fryer completely inoperative	<ul style="list-style-type: none"> Open circuit 	<ul style="list-style-type: none"> Fryer plugged in Check breaker or fuse at wall
Pressure not exhausting at end of Cook Cycle	<ul style="list-style-type: none"> Solenoid or exhaust line clogged 	<ul style="list-style-type: none"> Turn off and allow fryer to cool to release the pressure in frypot; have all lines, solenoid and exhaust tank cleaned
Relief valve vents	<ul style="list-style-type: none"> Operating pressure too high Deadweight clogged 	<ul style="list-style-type: none"> Turn off and allow fryer to cool to release the pressure in frypot; clean deadweight; see Preventive Maintenance Section
Pressure does not build	<ul style="list-style-type: none"> Not enough product in frypot Metal shipping spacer not removed from deadweight assy. Pressure not programmed Lid gasket leaking 	<ul style="list-style-type: none"> Place full capacity product in frypot when Use fresh oil. Remove shipping spacer; see Unpacking Instructions Section Check programming Reverse or replace lid gasket
Oil not heating	<ul style="list-style-type: none"> Drain valve open High temperature limit tripped 	<ul style="list-style-type: none"> Close drain valve. Reset high temperature limit; see Operating Components Section
Foaming or boiling over	<ul style="list-style-type: none"> See Boil-Over chart on fryer and beginning of Operation Section in this manual 	<ul style="list-style-type: none"> Follow Boil-Over procedures from chart
Oil not draining	<ul style="list-style-type: none"> Drain valve clogged 	<ul style="list-style-type: none"> Push cleaning rod through open drain valve
Filter motor won't run	<ul style="list-style-type: none"> Motor overheated 	<ul style="list-style-type: none"> Reset motor; see Filter Pump Motor Protector-Manual Reset Section

NOTICE

More detailed troubleshooting information is available in the Technical Manual, available at www.hennypenny.com, or 1-800-417-8405 or 1-937-456-8405.

**2-2.
ERROR CODES**

In the event of a control system failure, the digital display will show an “Error Message”. These messages are coded: “E04”, “E05”, “E06”, “E41”. A constant tone is heard when an error code is displayed, and to silence this tone, press any of the product buttons.

DISPLAY	CAUSE	CORRECTION
“E-4” “CPU TOO HOT”	Control board overheating	Turn switch to OFF position, then turn switch back to ON; if display still shows “E04”, the board is getting too hot; check for signs of overheating behind the control panel; once panel cools down the controls should return to normal; if “E04” persists, replace the control
“E-5” “OIL TOO HOT”	Oil overheating	Turn switch to OFF position, then back to ON; if display shows “E05”, the heating circuits and temperature probe should be checked; once the unit cools down, the controls should return to normal; if “E05” persists, replace the control.
“E-6A” “MAIN TEMP PROBE FAILED” (Open Circuit)	Temperature probe failure	Turn switch to OFF position, then back to ON; if the display shows “E06”, the temperature probe should be checked; once the temperature probe is repaired, or replaced, the controls should return to normal; if “E06” persists, replace the control.
“E-6B” “MAIN TEMP PROBE FAILED” (Shorted)		
“E-10”	High limit tripped (Software prior to version 1.60)	Check the error log to find out the fry pot temperature at the time the high limit tripped. If this temperature was very low, this could be a sign that the fry pot was turned on with low or no oil. If this was the case, fill the pot with oil and reset the high limit. If the trip temperature was several degrees above the oil set point temperature, test for a sticking contactor and replace if faulty. If the high limit tripped at an oil temperature, inspect the high limit thermocouples for carbon build up and clean if necessary. If no carbon found, see high limit troubleshooting.

DISPLAY	CAUSE	CORRECTION
<p>“E-10A” “HIGH LIMIT TRIPPED”</p>	<p>High limit tripped while vat main probe temperature was at or above 300°F.</p>	<p>Check the error log to find out the fry pot temperature at the time the high limit tripped. If this was several degrees above the oil set point temperature, test for a sticking contactor and replace if faulty. If the trip temperature was near the oil set point temperature, inspect the high limit thermocouples for carbon build up and clean if necessary. If no carbon found, see high limit troubleshooting.</p>
<p>“E-10B” “HIGH LIMIT TRIPPED”</p>	<p>High limit tripped while vat main probe temperature was below 300°F.</p>	<p>Check the error log to find out the fry pot temperature at the time the high limit tripped. If this temperature was very low, this could be a sign that the fry pot was turned on with low or no oil. If this was the case, fill the pot with oil and reset the high limit. If the high limit tripped at a higher temperature, inspect the high limit thermocouples for carbon build up and clean if necessary. If no carbon found, see high limit troubleshooting.</p>
<p>“E-10C” “HIGH LIMIT TRIPPED”</p>	<p>High limit tripped while actually cooking (Not simply in cook mode, but actually with cook cycle running).</p>	<p>Check the error log to find out the fry pot temperature at the time the high limit tripped. If this was several degrees above the oil set point temperature, test for a sticking contactor and replace if faulty. If the trip temperature was near the oil set point temperature, inspect the high limit thermocouples for carbon build up and clean if necessary. If no carbon found, see high limit troubleshooting.</p>
<p>“E-10D” “HIGH LIMIT TRIPPED”</p>	<p>High limit tripped less than 5 minutes after fryer was performing an AutoFilter or Quick Filter and the control returned to cook mode on its own after detecting that the oil was pumped up (based on temperature rise on level probe).</p>	<p>Check the error log to find out the fry pot temperature at the time the high limit tripped. If this was several degrees above the oil set point temperature, test for a sticking contactor and replace if faulty. If the trip temperature was near the oil set point temperature, inspect the high limit thermocouples for carbon build up and clean if necessary. If no carbon found, see high limit troubleshooting.</p>
<p>“E-10F” “HIGH LIMIT TRIPPED”</p>	<p>High limit tripped while filtering (including AutoFilter, Daily Filter, Polish, Dispose, Drain to Pan, Fill from Pan, etc.).</p>	<p>Check the error log to find out the fry pot temperature at the time the high limit tripped. If this was several degrees above the oil set point temperature, test for a sticking contactor and replace if faulty. If the trip temperature was near the oil set point temperature, inspect the high limit thermocouples for carbon build up and clean if necessary. If no carbon found, see high limit troubleshooting.</p>

DISPLAY	CAUSE	CORRECTION
<p>“E-10M” “HIGH LIMIT TRIPPED”</p>	<p>High limit tripped while fryer was in Melt Mode.</p>	<p>Check the error log to find out the fry pot temperature at the time the high limit tripped. If this temperature was very low, this could be a sign that the fry pot was turned on with low or no oil. If this was the case, fill the pot with oil and reset the high limit. If the high limit tripped at a higher temperature, inspect the high limit thermocouples for carbon build up and clean if necessary. If no carbon found, see high limit troubleshooting.</p>
<p>“E-10S” “HIGH LIMIT TRIPPED”</p>	<p>High limit tripped while vat was in Start-up Mode (not incl. Melt mode), but not while it was executing one of the filter operations.</p>	<p>Check the error log to find out the fry pot temperature at the time the high limit tripped. If this temperature was very low, this could be a sign that the fry pot was turned on with low or no oil. If this was the case, fill the pot with oil and reset the high limit. If the high limit tripped at a higher temperature, inspect the high limit thermocouples for carbon build up and clean if necessary. If no carbon found, see high limit troubleshooting.</p>
<p>“E-10Y” “HIGH LIMIT TRIPPED”</p>	<p>High limit tripped less than 5 minutes after user responded “YES” to an “Is Pot Filled?” question.</p>	<p>Check the error log to find out the fry pot temperature at the time the high limit tripped. If this temperature was very low, this could be a sign that the fry pot was turned on with low or no oil. If this was the case, fill the pot with oil and reset the high limit. If the high limit tripped at a higher temperature, inspect the high limit thermocouples for carbon build up and clean if necessary. If no carbon found, see high limit troubleshooting.</p>
<p>“E-13”</p>	<p>Pressure transducer failed</p>	<ul style="list-style-type: none"> • Replace pressure transducer
<p>“E-14” “PRESSURE TOO HIGH”</p>	<p>Pressure is too high within the frypot</p>	<ul style="list-style-type: none"> • Check deadweight chamber for any obstruction • Check the steam exhaust passage for obstruction

DISPLAY	CAUSE	CORRECTION
<p>“E-15C” “DRAIN VALVE ERROR”</p>	<p>The control energized the drain valve to close it, and waited a reasonable amount of time, but didn’t see the expected feedback signal that would have confirmed that the drain valve was fully closed.</p>	<p>Check the drain valve for obstruction. Carefully remove any obstruction found. If no obstruction, check to make sure both connections to the drain valve are plugged in securely. If connections are secure, operate the drain valve using the drain valve test in tech mode. If no drain valve movement, test to make sure the drain valve is getting 24VDC from control board when testing both directions (open and closed) from connector P9 pins 3&4. If voltage is present and no movement, replace drain valve motor. If no DC voltage, replace control board</p>
<p>“E-15P” “DRAIN VALVE ERROR”</p>	<p>The control energized the drain valve to open it, and waited a reasonable amount of time, but didn’t see the expected feedback signal that would have confirmed that the drain valve was fully open.</p>	<p>Check to make sure both connections to the drain valve are plugged in securely. If connections are secure, operate the drain valve using the drain valve test in tech mode. If no drain valve movement, test to make sure the drain valve is getting 24VDC from control board when testing both directions (open and closed) from connector P9 pins 3&4. If voltage is present and no movement, replace drain valve motor. If no DC voltage, replace control board</p>
<p>“E-18A” “LEVEL SENSOR FAILED” (Open Circuit)</p>	<p>The oil level probe has failed</p>	<ul style="list-style-type: none"> • If circuit is open, check connection • Replace probe
<p>“E-18B” “LEVEL SENSOR FAILED” (Shorted)</p>		
<p>“E-41P” “-1- LOST”</p>	<p>System data lost. Both the RAM copy and stored copy of the settings have been lost. Settings are reset to default</p>	<ul style="list-style-type: none"> • Replace control board if occurs repeatedly
<p>“E-41S” “SYSTEM DATA LOST”</p>	<p>System data lost. Both the RAM copy and stored copy of the settings have been lost. Settings are reset to default</p>	<ul style="list-style-type: none"> • Replace control board if occurs repeatedly

DISPLAY	CAUSE	CORRECTION
“E-46C” “INTERNAL SD MEM ERR”	Issue with microSD chip	<ul style="list-style-type: none"> • Check to ensure chip is not ejected from slot
“E-46W” “DATA SAVE FAILED”	Unable to communicate and save data to the microSD chip Corrupt file	<ul style="list-style-type: none"> • Replace control board if occurs repeatedly
“E-47” “ANALOG SYSTEM OR 12 VOLT FAILED”	Problem reading the A-to-D Analog to Digital converter inputs	<ul style="list-style-type: none"> • Initialize the CPU board • Replace control board
“E-48” “INPUT SYSTEM ERROR”	Failure of the CPU board	<ul style="list-style-type: none"> • Replace control board
“E-54C” “MAIN TEMP CIRCUIT FAILURE”	Fault on the CPU board	<ul style="list-style-type: none"> • Initialize the CPU board • Replace control board
“E-54D” “MAIN TEMP DSC ERROR”	Fault on the CPU board	<ul style="list-style-type: none"> • Initialize the CPU board • Replace control board
“E-70A” “FAN JUMP MISSING”	Jumper wire is loose or missing from 15 pin connector	<ul style="list-style-type: none"> • Check connector for loose connection
“E-70B” “PWR SWITCH OR WIRES FAILED”	Short in wires/ loose connection Power switch may be faulty	<ul style="list-style-type: none"> • Check connection • Replace power switch

DISPLAY	CAUSE	CORRECTION
“E-70C” “DRN JUMPER MISSING”	Loose connection on the 15 pin connector	Check connection
“E-82” “SELCTOR VALVE FAILURE”	The selector valve failed calibration or not responding	<ul style="list-style-type: none"> • Check motor, encoder or wiring • If unit is not equipped with a selector valve and gives this error, check settings in T-4 (Tech Mode) to confirm settings are correct.
“E-84B” “LID NOT LOCKED”	<ul style="list-style-type: none"> • Lid handle not properly locked • Failed electric lid lock motor 	<ul style="list-style-type: none"> • Confirm handle is pushed all the way down • Test/ replace motor
“E-84C” “PRESSURE PIN DID NOT ACTIVATE”	<ul style="list-style-type: none"> • Pressure pin did not fully engage 	<ul style="list-style-type: none"> • Check to see if the pin is activating the switch • Test switch
“E-84D” “PRESSURE PIN STUCK OR NOT CONNECTED”	<ul style="list-style-type: none"> • <u>Cannot open lid</u>-Pin is stuck and has not dropped down • <u>Can open lid</u>-wire may be disconnected or monitoring switch failed 	<ul style="list-style-type: none"> • If lid pin is stuck, remove lid cover and manual free pin • Check wire connections and reconnect loose wires • Replace faulty wires • Test switch • Replace switch if needed
“E-86B” “PRESSURE STUCK ON”	<ul style="list-style-type: none"> • Sticking solenoid • Clogged pressure exhaust port • Faulty pressure transducer 	<ul style="list-style-type: none"> • Test solenoid • Check ports and unclog if necessary • Test transducer
“E-93” “24V DC SUPPLY”	<ul style="list-style-type: none"> • Disconnected from control • Short in drain motor or selector valve motor 	<ul style="list-style-type: none"> • Check plug on back of control • Test motors

SECTION 3: PROGRAMMING

3-1. MAIN MENU



Press and hold the  button until *MAIN* shows in the display. Once the menu activates, release the button.

The Main Menu options are displayed as follows:

1. FILTER
2. INFO MODE
3. USB/DATA
4. PROGRAM
5. CLOCK SET
- x. EXIT MENU

3-2. PROGRAMS





This section shows how to access the programming (“PROG”) menu that access the products, cook and special program and tech mode.

- | | |
|--------------------|-------------------|
| 1. PRODUCTS | 6. FILTER CONTROL |
| 2. COOK MENUS | 7. TECH MODE |
| 3. SPECIAL PROGRAM | 8. STATS MODE |
| 4. DATA COMM | 9. LANGUAGE |
| 5. HEAT CONTROL | x. EXIT MENU |

**3-3.
SPECIAL
PROGRAMMING**

SP-1 • TEMP UNITS
SP-2 • LANGUAGE
SP-3 • SYSTEM INIT
SP-4 • RADIO SYSTEM ENABLED?
SP-5 • AUDIO VOL (Loudness)
SP-6 • AUDIO TONE (Frequency)
SP-7 • MELT CYCLE
SP-8 • START-UP POLISH ENABLED?
SP-9 • START-UP GO WHERE?
SP-10 • COOK MENUS OPTION
SP-11 • COOK MENU BUTTONS
SP-12 • COOK DONE GO WHERE?

This section shows how to access the Special Program area of the controls in order to program cook menus, clock, and other features.

1. Push and hold  until the display reads *MAIN*.
2. Press the  again to access the next set of options.
3. Press 4 to enter the “PROG” menu.
4. Press 3 to enter “SPCL PROG”.
5. Enter the code: 1, 2, 3
6. Use the left or right arrows to navigate through the options.

SP-13 • AUTO-MENU MINUTES
SP-14 • AUTO-MENU GO WHERE?
SP-15 • COOL TEMP
SP-16 • PROD PROG T1>T2>T3)?
SP-17 • BULK DISPOSE?
SP-18 • BULK SUPPLY?
SP-19 • COOKING: SHOW PSI?
SP-20 • CHANGE MGR CODE
SP-21 • CHANGE USAGE CODE
SP-22 • CLEAN-OUT TYPE
SP-23 • CLEAN-OUT TEMP
SP-24 • CLEAN-OUT MINUTES

SP-1 • TEMPERATURE DISPLAY UNITS

1. Use the + or - to change between Fahrenheit (F°) or Celsius (C°).

SP-2 • OPERATION LANGUAGE

1. Use the + or - buttons to scroll through the list of languages.

SP-3 • SYSTEM INITIALIZE

1. Press and hold the button next to “hold->” for three seconds.
2. System will re-initialize back to default settings.

SP-5 • AUDIO VOLUME (Loudness)

1. Use the + or - buttons will adjust the volume of the speaker between 0-10.
2. Press the button next to “test” on the display.

**3-3.
SPECIAL
PROGRAMMING
(CONT.)**

SP-6 • AUDIO TONE (Frequency)

1. Press the + or - to adjust the frequency setting,
2. Press the button next to “test” on the display.

SP-7 • MELT CYCLE

Specify the desired Melt Mode heating cycle.

1. Use the + or - to select wither “Solid” or “Liquid”.

SP-8 • START-UP POLISH ENABLED?

Specify whether or not an automatic polish operation should be performed as part of the normal, morning startup process.

1. Use the + or - to select either “YES” or “NO”.

SP-9 • START-UP GO WHERE?

Specify where the control should go after exiting Melt. Choices are “STAY PROD”, “PREV MENU”, or go specifically to any of the ten Cook Menus.

1. Use + or - to navigate through options.

SP-10 • COOK MENUS (Cook Menu Configuration)

1. Use the + or - buttons to navigate through cook menu options.
 - “4+TITLE”
 - “5+NEXT”
 - “6 ITEMS”

See *MENU OPTIONS* for descriptions and examples.

SP-17 • BULK DISPOSE?

1. Use the + or - buttons to navigate through the three options:
 - “NONE”
 - “FRONT”
 - “REAR”
2. “NONE”- Oil dispose is by draining into a disposal cart or shuttle.
3. “FRONT”- Dispose by pumping through the front hose connection by press and holding the illuminated button.
4. “REAR”- Dispose by pumping through the rear plumbing connection.

**3-3.
SPECIAL
PROGRAMMING
(CONT.)**

SP-18 • BULK OIL SUPPLY?

1. Use the + or - buttons to select either “YES” or “NO” for whether or not a bulk oil supply is available for refilling the ATO oil tank and vat with fresh oil.

**3-4.
INFO MODE**

Info Mode offers various diagnostic displays. To access Info Mode, either::

1. Press and hold  and  until “=INFO MODE=” flashes on the screen.

Or

1. Press and hold  until “*MAIN*” flashes on the screen.
2. Press the “2. INFO” button.

Use the left or right arrow buttons to navigate through the options:

- E-Log
- Last Load
- Daily Stat
- Review Usage
- Activity Log
- CPU Info
- Temperatures
- Digital Inputs-1
- Digital Inputs 2
- Inputs-3 (Bulk Oil Inputs)
- Pressure Inputs
- Fryer Outputs
- Drain Valve Status
- Selector Valve
- Pump Outputs
- Electric Lid Lock
- Analog Inputs
- Memory Info
- USB Drive Status
- ATO (Auto-Topoff) Level

E-Log

When E-Log is accessed, this displays the history of the previous 25 error codes starting with the most recent code first. Each code includes the date and time that the error occurred.

Last Load

Information about the most recent cook cycle, including total cook time, stopped early or left beeping too long, and min/max/avg temperatures.

Daily Statistics

Operating statistics for each of the past seven days, including hours on, cook cycles, number of filters and etc.

**3-4.
INFO MODE
(CONT.)**

Review Usage

Ongoing accumulation of operating statistics.

Stats accumulate until manual rest.

To reset (requires password), available by navigating all the way to the bottom of the list.

Activity Log

History of Activity Log events:

- On/Off
- Start/Stop cook
- Filter
- Pan removed or replaced

CPU Info

Live temperature reading for the CPU (controller) temperature.

Temperatures

Live temperature readings for the Main oil temp., the Level Probe temp., and the Bottom (bottom of vat) temperature.

The “Lvl” level probe shown here is the one actually in use – upper or lower level probe -- as selected in Filter Ctrl Programming mode.

Digital Inputs-1

√ = Signal present

- = No signal present

A = Power Switch

H = High Limit

D = Drain Switch Jumper

S = Power Switch Interlock

F = Fan Switch Jumper

Digital Inputs-2

√ = Signal present

- = No signal present

24dc = 24 DC Supply

Pan = Filter Drain Pan

*Lid = Lid Liner Pin

*Lid Liner Pin shows “OK” if pin is down.

Lid Liner Pin shows “PR” when pin is raised (under pressure).

3-4.
INFO MODE
(CONT.)

Bulk Oil Inputs

√ = Signal present

- = No signal present

DTF = Discard Tank Full

If √ is present, tank is full and cannot dispse to it.

HDP = High Dispose Pressure (optional)

If √ is present, dispose pumping caused high pressure.

AFR = ATO Fill Request (optional)

If √ is present, switch is asking to pump Bulk Supply Oil to refill the ATO tank.

Pressure Inputs

Shows readings from the pressure transducer:

“OK” = Safe to open lid (not under pressure)

“PR” = Lid under pressure, cannot open

Fryer Outputs

* = On

- = Off

Pri = Primary Contactor

Ht = Heat (regulating) Contactor

Pr = Pressure Solenoid

Drain Control

Par = Partially open

Stp = Forced Stop

Opn = Fully Open

Cls = Fully Closed

The current state of the drain valve is indicated with a “▶”.

The below “At” indicates the drain valve position.

0 = Fully Closed

20+ = Fully Open

Selector Valve (Bulk Oil Fryers Only)

If unit is not equipped with a Bulk Oil System, “No Selector Valve” will read in the display.

“E=001” = Encoder Position

Lower left display shows the activity of the valve.

STPD

FWD

REV

Lower right display shows the current port position.

**3-4.
INFO MODE
(CONT.)**

Pump Outputs

* = On

- = Off

Fltr = Filter Pump

ATO = Topoff Pump

Bulk = Bulk Oil Supply

*Disp = Dispose Valve

*Dispose valve is optional

Electric Lid Lock

“R:” shows current request: Lock, Unlock

√ = request has been achieved and verified

“Mtr” = Motor

- - = Off
- “<_” = Retracting
- “->” = Extending

“R” / “X” = Retracted limit switch or Extended limit switch currently pressed.

Analog Inputs

Analog input readings directly from the ADC chip.

Displayed as volts and as ADC counts(bits).

Use the Up and Down arrows to step through available inputs.

Memory Status (MEM INFO)

Shows the status and size of the control’s internal microSD storage memory.

√ = Memory OK

X = Memory problem

Use the arrow buttons to scroll down to see free space, used space and volume name.

USB Drive Status (USB INFO)

Shows the status and size of the USB flash drive, if present.

√ = Flash Drive OK

X = Flash Drive not present or drive error

Scroll down to see flash drive free space, used space and volume name.

**3-4.
INFO MODE
(CONT.)**

ATO-Topoff Status (ATO LEVELS)

LVL = Levels

- “FULL”
- “LOW”
- “_ _ _”



Will show when an assessment is not possible.

Delta shows the temperature difference between the main probe and the level probe.

Cnt = Count

Count shows how many ATO pulses have been generated in the current topoff attempt.

**3-5.
TECH MODE**

1. Press and hold  until “*MAIN*” flashes on the screen.
2. Press and release  to go to the second list of menu options.
3. Press the “4.PROG” button.
4. Press the  to navigate through the menu options. Select “7.TECH MODE”.
5. Enter the code 11221122.

Use the left or right arrow buttons to navigate through the options:

T-1 • SOFTWARE ID’S
T-2 • META DATA
T-3 • FRYER TYPE
T-4 • FRYER HAS SEL VALVE
T-5 • FRYER SERIAL NUMBER
T-6 • PUSH BUTTON TEST
T-7 • DISPLAY TEST
T-8 • AUDIO TEST
T-9 • LVL TEMP OFFSET ADJ
T-10 • MAIN TEMP OFFSET ADJ
T-11 • BOTTOM TMP OFFSET ADJ
T-12 • SPARE TMP OFFSET ADJ
T-13 • CPU° TEMP OFFSET ADJ
T-14 • INPUTS-1
T-15 • INPUTS-2
T-16 • INPUTS-3
T-17 • PRESSURE INPUTS
T-18 • OUTPUTS
T-19 • DRN VALVE
T-20 • SEL VALVE FWD/REV

T-21 • SEL VALVE PORTS
T-22 • PUMPS
T-23 • OPS SYSTEM ENABLED?
T-24 • RADIO COM
T-25 • ANALOG CHANNELS
T-26 • HEAT CTRL
T-27 • ALLOW LID OPEN
T-28 • LID LINER PIN -MUST- ACUATE
T-29 • AFTER COOK PRESSURE STUCK ON GIVES ERROR
T-30 • AUTO-CYCLE PRESSURE SOLENOID?
T-31 • BLOCKED DRAIN AUTO-REV RETRIES
T-32 • ATO DELTA -FULL-
T-33 • ATO DELTA -LOW-
T-34 • QUICK FLTR FILL TO LVL PROBE TEMP RISE
T-35 • DAILY+POL FILL TO LVL PROBE TEMP RISE
T-36 • ANY FILL, LVL PROBE MIN DETECT
T-37 • IGNOT E93 24VDC ERROR?
T-38 • CHANGE TECH CODE
T-39 • DO TOTAL INIT

T-1 SOFTWARE ID’S

Shows th active version of software in the middle display.

T-3 FRYER TYPE

Shows what type of fryer (pressure or open) in the middle display.

To change the fryer type:

1. Press the illuminated lower-left button to change from Pressure to Open.

The model type will change in the middle display.

**3-5.
TECH MODE
(CONT.)**

T-4 FRYER HAS SELECTOR VALVE

- If the unit is not equipped with a selector valve, the middle display should read “NO”.
- If the unit is equipped with a selector valve, the middle display should read “YES”.
- If incorrectly labeled, press the illuminated buttons next to the + or -.

T-5 FRYER SERIAL NUMBER

This section displays the unit’s serial number

T-6 BUTTON TEST

This section test all the buttons to confirm all are working correctly. Press any of the non-illuminated buttons to enter the test mode.

The screen will return to normal operation after 3 seconds of no activity.

T-7 DISPLAY TEST

This section test all of the LED and display lights. Press the illuminated button next to the type of test listed on the display.

- Press and hold the button on the LED test to test all the lights on the buttons
- Press and release the buttons next to the display test options to circulate through the different sections of the display.

T-8 AUDIO TEST

- Press the button next to “Start” to start the Audio volume test.
- Press and hold the button next to “Hold” to test the current volume.

T-9 LVL TEMP OFFSET ADJ

Shows the current temperature of the oil at the level probe.

1. To adjust the temperature, press and hold the button next the “Temp”.
2. With the button held, press the + or - to adjust the temperature
3. To adjust the offset, press and hold the button next to the “Ofst”.
4. With the button held, press the + or - to adjust the offset.

T-10 MAIN TEMP OFFSET ADJ

Shows the current main temperature of the oil.

1. To adjust the temperature, press and hold the button next the “Temp”.
2. With the button held, press the + or - to adjust the temperature
3. To adjust the offset, press and hold the button next to the “Ofst”.
4. With the button held, press the + or - to adjust the offset.

T-11 BOTTOM TMP OFFSET ADJ

Shows the current temperature of the oil at the bottom probe.

1. To adjust the temperature, press and hold the button next the “Temp”.
2. With the button held, press the + or - to adjust the temperature
3. To adjust the offset, press and hold the button next to the “Ofst”.
4. With the button held, press the + or - to adjust the offset.

T-12 SPARE TMP OFFSET ADJ

Accesses a spare temperature probe input.

**3-5.
TECH MODE
(CONT.)**

T-13 CPU TEMP OFFSET ADJ

This display shows the temperature of the control board. To adjust the offset;

1. Press and hold the button next to "Ofst".
2. Press the buttons next to the - or the + to adjust the offset down or up.

T-14 INPUTS-1

A H D S F P M shows in the middle display.

A = Power Switch
H = High Limit
D = Drain Switch Jumper
S = Power Switch Interlock
F = Fan Switch Jumper
P = Not in use at this time
M = Not in use at this time

√ = signal present
- = signal not present

T-15 INPUTS-2

24dc = 24 DC Supply
Pan = Filter Drain Pan
Lid = Lid Liner Pin

√ = active
- = inactive
OK = lid pin is down (not under pressure)
Flashing PR = lid pin is raised (under pressure)

T-16 INPUTS-3 Bulk Oil

DTF, HDP, AFR show in the middle display

DTF = Discard Tank Full
√ = Tank is full; cannot dispose oil to tank

HDP = High Dispose Pressure
√ = Dispose pumping caused high pressure

AFR = ATO Fill Request
√ = Switch is asking to pump Bulk Supply Oil to refill the ATO tank

**3-5.
TECH MODE
(CONT.)**

T-17 PRESSURE INPUTS

This section shows the current psi of the lid. If “OK” is on the display, the lid is safe to open. Otherwise, “PR” flashes showing lid is under pressure

The bottom display reads “Lid Pin”. If “OK” is on the display, the lid pin is down. Other wise, “PR” flashes showing the pin is raised (under pressure).

T-18 OUTPUTS

Press the illuminated buttons next to the feature to test

Pri = Primary Contactor

Ht = Heat (regulating) Contactor

Pr = Pressure Solenoid

* = On

- = Off

T-19 DRN VALVE

NOTE: Be sure drain pan is in place before testing drain valve.

This section test the drain valve functions. A ► will show next to the drain valves current state.

Par = Partially open

Stp = Forced stop

Opn = Fully open

NOTE: The number in the middle will display the position “At” where the drain valve stopped from 00-20.

ClS = Fully closed

T-20 SEL VALVE FWD/REV

This section test the selector valve rotation position

Cst = Current state

Stp = Stop the selector valve rotation

Fwd = Press to rotate the selector valve forward.

Rev = Press to rotate the selector valve in reverse.

The “Enc” (encoder) will show when the encoder switch is activated during rotation.

**3-5.
TECH MODE
(CONT.)**

T-21 SEL VALVE PORTS

This section test the positioning of each port on the selector valve.

P0 = At pot
P1 = At dispose
P2 = At ATO refill
Enc = Encoder position

If the selector valve does not function properly, “FAIL” will show on the middle-left display.

T-22 PUMPS

Press the illuminated button next to the function to start test.

* = On
- = Off

Fltr = Filter Pump
ATO = JIB Pump
Drn C = Drain Valve

T-23 OPS SYSTEM ENABLED?

This section allows the OPS system to be enabled for store use.

Press the + or - to either select “YES” or “NO”.

T-24 RADIO SYSTEM

Section shows if the unit is equipped with a radio system.

To change the option, pres the + or - to select “NO” or “YES”.

T-25 ANALOG CHANNELS

Displays the various analog inputs.

T-26 HEAT CTRL

Displays the performance data monitored by the heating algorithm.

**3-5.
TECH MODE
(CONT.)**

T-27 ALLOW LID OPEN

Displays the PSI limit value that the lid can be opened after a cook cycle. If the PSI is above this setting, the lid will remain locked and display “WAIT” until the PSI is at or below this value.

T-28 LID LINER PIN -MUST- ACTUATE

Displays the PSI that the monitoring switch on top of the lid liner pressure pin must actuate.

T-29 AFTER COOK, PRESSURE STUCK ON GIVE ERROR

Displays how many seconds after pressure should be depleted until it gives the appropriate Error Code.

T-30 AUTO-CYCLE PRESSURE SOLENOID?

This section allows the solenoid to be auto-cycled after every cook cycle.

Pushing the up or down arrows to select either “YES” or “NO”.

T-31 BLOCKED DRAIN AUTO-REV RETRIES

AUTO-REV = Auto-Reverse

The value displayed is the number of times the drain valve tries to close if it does not successfully close the first time. If the drain valve does not fully close, the unit will beep and the drain will automatically open, allowing the user to remove any obstruction.

T-32 ATO DELTA -FULL-

T-33 ATO DELTA -LOW-

The temperatures displayed in each of the sections are the threshold to determine if the oil level is full or low.

T-34 QUICK FLTR, FILL TO LVL PROBE, TEMP RISE

The temperature displayed is at what point the oil stops pumping during the fill phase of the Quick Filter.

T-35 DAILY+POL, FILL TO LVL PROBE, TEMP RISE

The temperature displayed is at what point the oil stops pumping during the fill phase of a Polish.

T-36 ANY FILL, LVL PROBE MIN DETECT

If the temperatures in the previous sections happen too quickly, the controls ignore them and the oil pumps for the value displayed.

**3-5.
TECH MODE
(CONT.)**

T-37 IGNORE E93 24VDC ERROR?

This is only for Alpha units.

T-38 CHANGE TECH CODE

Call Henny Penny Technical Support for details.

T-39 TOTAL INIT

Press and hold the button next the “hold” on the display to institutionalize the control board.

SECTION 4: MAINTENANCE

4-1. INTRODUCTION

This section provides checkout and replacement procedures, for various parts of the fryer. Before replacing any parts, refer to the Troubleshooting Section to aid you in finding the cause of the malfunction.

4-2. MAINTENANCE HINTS

1. A multimeter will help you to check the electric components.
2. When the manual refers to the circuit being closed, the multimeter should read zero unless otherwise noted.
3. When the manual refers to the circuit being open, the multimeter should read infinity.



Do not move the fryer with hot oil in the vat or filter pan. Severe burns can result from splashing hot oil.

**4-3.
CONTROL BOARD
REPLACEMENT**



Disconnect the power or electrical shock will occur.



1. Use a Phillips head screwdriver to remove the two screws securing the control board to the front shroud.

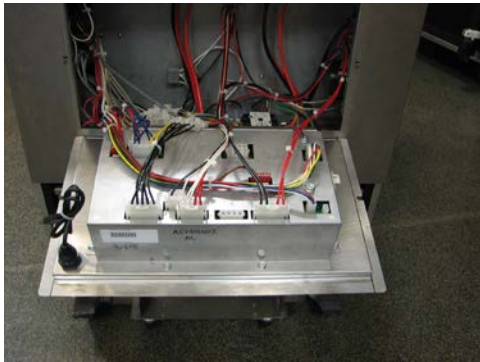

2. Press in on the bottom of the board and rotate down until it rests on the shroud.

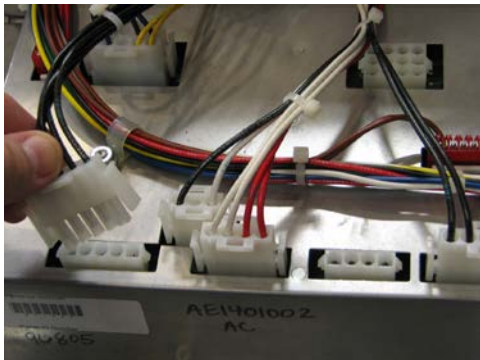

3. Disconnect all the connectors on the back of the control board.

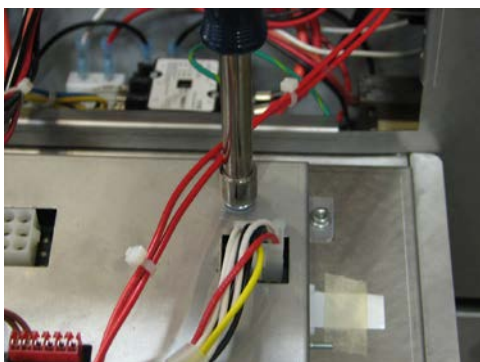

4. Use a 3/8in. nut-driver or socket and remove the nut securing the ground wire to the control board.
5. Remove old control board.
6. Place new control board onto the unit with the tab inserted into the slot. Let the control board rest on the shroud.
7. Finish control board installation in reverse order.

**4-4.
POWER SWITCH
REPLACEMENT**

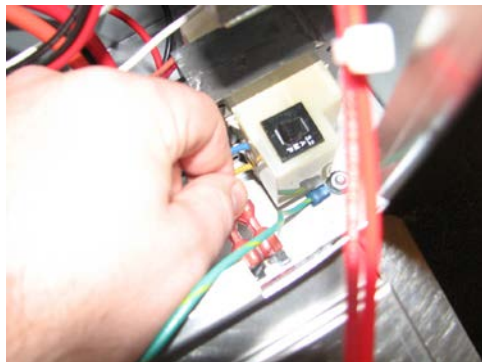
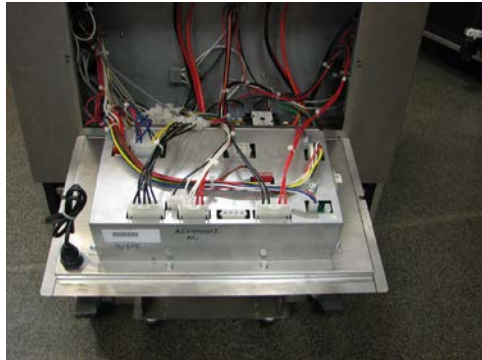

Disconnect the power or electrical shock will occur.

1. Lower the control board (see Control Board Replacement).
2. Mark the wires and disconnect.
3. Use a flat-blade screwdriver to press down on the locking tabs.
4. Pull the switch out of the shroud.
5. Place new switch in place.
6. Attach the wires to the new switch.
7. Slide new power switch into the shroud.
8. Secure the control board back in place.
9. Test operation.

4-5.
USB PORT
REPLACEMENT



1. Remove the USB cap.
2. Use an adjustable wrench to remove the locking nut.
3. Remove the cap from the USB assembly.
4. Lower the control board (see Control Board Replacement).
5. Disconnect the USB plug from the receiver on the back of the control board.
6. Pull USB port assembly out of the hole in the control board.
7. Place the new USB port assembly into the hole in the control board.
8. Use one adjustable wrench to hold the USB port in place while using another adjustable wrench to tighten the locking nut.
9. Plug the USB plug into the receiver on the back of the control board.
10. Secure the control board back in place.

**4-6.
HIGH LIMIT
THERMOCOUPLES**



Disconnect the power or electrical shock will occur.

1. Lift the lid and tilt back to lock into place.
2. Use a Phillips head screwdriver to loosen the heating element spreaders.
3. Use a Phillips head bit to remove the screws from the left-hand (from the front of unit) side panel.
4. Lower side panel and set aside.
5. Use a 1/2in. wrench to loosen the compression fitting.
6. Pull the thermocouple from the fitting.
7. Lower the control board (see Control Board Replacement).
8. Trace wires to the high limit modules on the sidewall of the control board area.
9. Remove the wires from high limit module.
10. Use a 1/2in. wrench to remove the fitting from the vat wall.
11. Locate the new thermocouple and fitting.
12. Apply thread sealant to the fitting and thread into the vat wall. Tighten with 1/2in. wrench.
13. Insert the new thermocouple into the compression fitting.

NOTE: Be sure the new thermocouple slides into the heating element spreader.
14. Use a 1/2in. wrench to tighten the compression fitting onto the thermocouple.
15. Use a Phillips head screwdriver to tighten the heating element spreader.
16. Connect the new thermocouple wires to the high limit module.
17. Place side panel back in place and secure with the screws.
18. Secure the control board back in place.

**4-7.
HIGH LIMIT
THERMOCOUPLES**



Disconnect the power or electrical shock will occur.

1. Lower the control board (see Control Board Replacement).
2. Locate the faulty high limit module on the left-hand (from the front) side wall.
3. Mark all the wire locations.
4. Disconnect all the wires.
5. Use a 3/8in. socket or nut-driver to remove the nuts.
6. Remove the two (2) metal lock strips.
7. Slide the high limit module off of the mounting studs.
8. Slide the new high limit module onto the mounting studs.
9. Place the two (2) metal lock strips onto the studs and secure in place with a 3/8in. socket or nut-driver.
10. Reconnect the wires as removed.
11. Secure the control board back in place.

**4-8.
PRIMARY
CONTACTOR
REPLACEMENT**

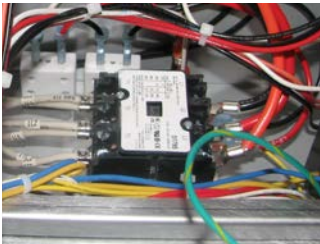

Disconnect the power or electrical shock will occur.

1. Lower the control board (see Control Board Replacement).
2. Mark the location of the wires.
3. Use a Phillips head screwdriver to remove the L1, L2 and L3 wires from the contactor.
4. Use a Phillips head screwdriver to remove the wires on the T1, T2 and T3 side of the contactor.
5. Disconnect the wires coming from the T1, T2 and T3 on the contactor.
6. Disconnect the RS1 and RS2 yellow wires.
7. Use a 3/8in. socket or nut-driver to remove the nuts that secure the contactor to the shroud.
8. Lift up on the contactor to remove it from the studs.
9. Place the new contactor onto the studs.
10. Use a 3/8in. socket or nut-driver to secure in place.
11. Replace wires as they were removed.
12. Secure the control board back in place.
13. Test operation.

**4-9.
HEAT CONTACTOR
REPLACEMENT**



Disconnect the power or electrical shock will occur.

1. Lower the control board (see Control Board Replacement).
2. Mark the locations of the wires.
3. Use a Phillips head screwdriver to remove the blue wires in A1 and A2.
4. Use a Philips head screwdriver to remove the coming from the 1L1, 3L2 and 5L3 side on the contactor.
5. Use a Phillips head screwdriver to remove the wires from the 2T1, 4T2 and 6T3 side of the contactor.
6. Use a 3/8in. socket or nut-driver to remove the two nuts on the mounting plate.
7. Lift up on the contactor so the mounting plate clears the studs.
8. Place new contactor on the studs as the old contactor was removed.
9. Use a 3/8in. socket or nut-driver to secure in place.
10. Reconnect all the wires where previously removed.
11. Secure the control board back in place.
12. Test operation.

**4-10.
AIF MULTI-TAB
TRANSFORMER
REPLACEMENT**



Disconnect the power or electrical shock will occur.

1. Lower the control board see Control Board Replacement).
2. Label the locations of the wires and disconnect.
3. Use a 3/8in. nutdriver or socket to remove the four (4) nuts.
4. Remove the transformer from the studs.
5. Place new transformer onto the studs and secure with a 3/8in. nutdriver or socket.
6. Reconnect the wires to the correct locations.
7. Close control panel.
8. Return power back to the unit.
9. Test operations.



**4-12.
CONTROL
TRANSFORMER
REPLACEMENT**



Disconnect the power or electrical shock will occur.

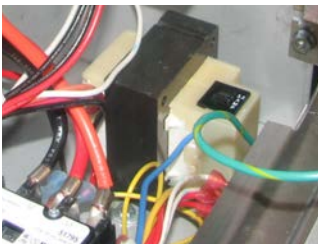

1. Lower the control board see Control Board Replacement).
2. Locate the 5-pin connector leading from the transformer. Disconnect the connector.
3. Use a 3/8in. socket and extension, remove the two (2) nuts that secure the transformer to the shroud.
4. Lift up on the transformer to remove it from the studs.
5. Place the new transformer onto the studs.
6. Secure the transformer in place with a 3/8in. socket and extension.
7. Connect the 5-pin connector to the 5-pin connector jumper coming from the control board.
8. Secure the wires with tie-strips to the existing wiring harness.
9. Secure the control board back in place.

**4-13.
PUMP MOTOR
REPLACEMENT**

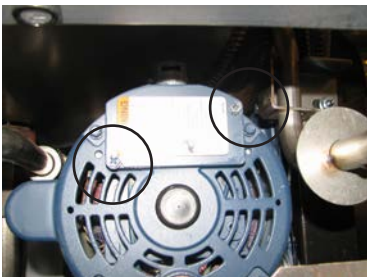

1. Remove the condensation pan.
2. Remove the Fresh Oil Tank.
3. Remove the drain pan.
4. Use an adjustable wrench to remove the flex line (hard line may be present for newer builds) and pipe connections from both ends of the pump motor.
5. Use a Phillips head screwdriver to remove the two screws that secure the plate onto the pump motor.
6. Mark the locations of the black wires.
7. Remove the black wires from the pump motor.
8. Use a flat blade screwdriver to remove the conduit retainer ring from the pump motor.
9. Remove the conduit retainer and conduit from the pump motor.

**4-13.
PUMP MOTOR
REPLACEMENT
(CONT.)**

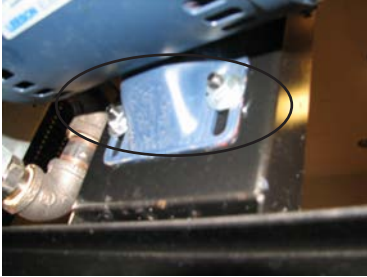

10. Use a 1/2in. wrench to remove the two nuts on the mounting plate.
11. Lift up on the pump motor then pull it off the mounting plate.
12. Place the new pump motor onto the mounting plate so the hanger bolts rest on the top lip and slide down so the studs are in line with the holes in the pump motor base.
13. Use a 1/2in. wrench to secure the pump motor to the mounting plate.
14. Use an adjustable to reconnect the lines to the correct port of the pump motor.

**4-14.
REMOVE THE LID
COVER**



1. Use a phillips head screwdriver to remove the two (2) screws located in the back of the lid.
2. Use a flat blade screwdriver to gently pry the front of the lid cover so that the locater pegs slide out of their holes.
3. Lift up on the back of the lid cover.
4. Set the lid cover to the side.
5. The lid components are now accessible.
6. Reverse the previous steps to reinstall the lid cover.

**4-16.
LOCK POSITION
SWITCHES
REPLACEMENT**

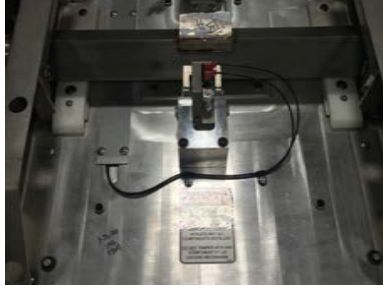

1. Remove the lid cover (see Remove Lid Cover section).
2. Mark the location of each wire.
3. Disconnect the wires.
4. Use a phillips head screwdriver to remove the two (2) screws that secure the switch to the mounting plate.
5. Place the new switch in place.
6. Secure the switch with the two (2) screws previously removed.
7. Reconnect the wires.

**4-17.
FLEX TUBE
REPLACEMENT**

When installing new flex tubes, follow the listed guidelines to prevent failures of the new flex tube.

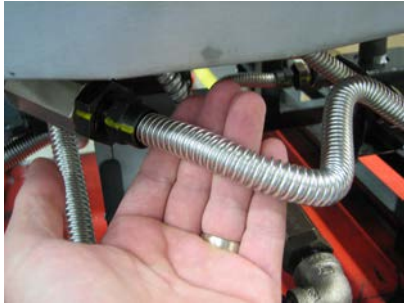

1. Do not bend the flex tube within 4 finger widths of the end fittings.



2. When bending the flex tube, the bend should not be smaller than a golf ball in radius.



3. All flex tubes should be torque finger tight, then a $\frac{1}{4}$ turn.
4. When tightening then flex tube's fitting, hold the fitting that the nut is tightening to, while torquing, to avoid twisting of the flexible tube.
5. Discard any tube bent more than 3 times in the same area of tube.

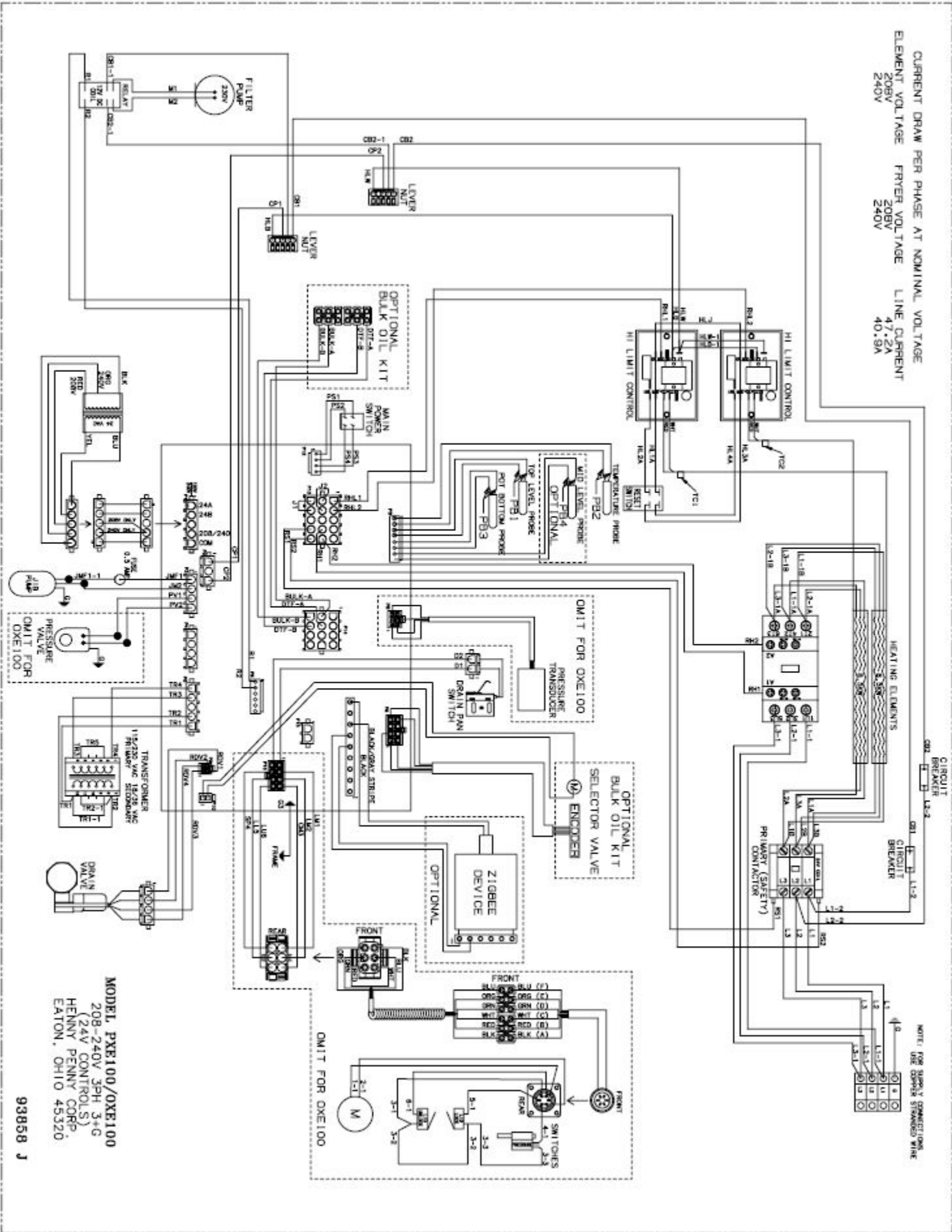

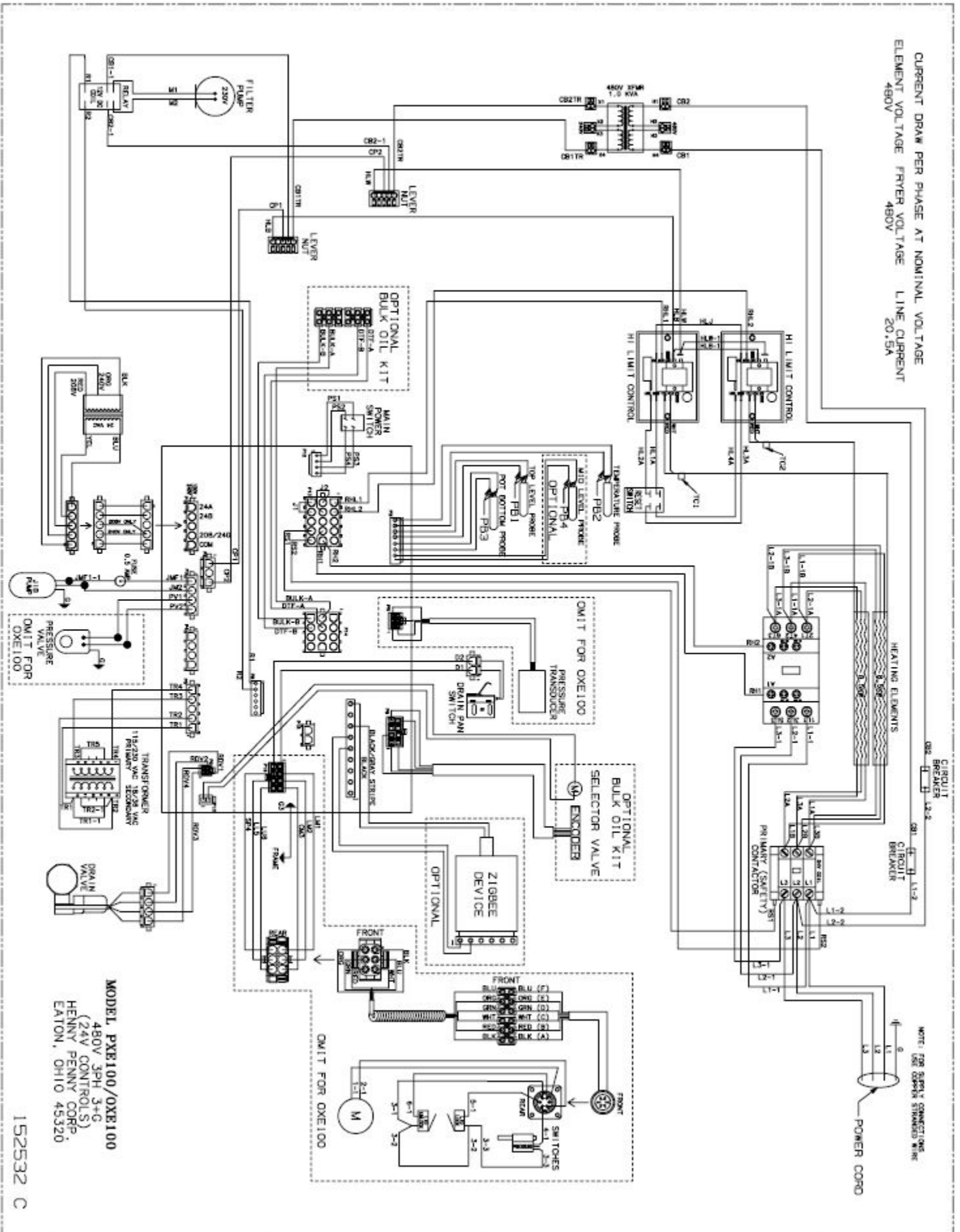

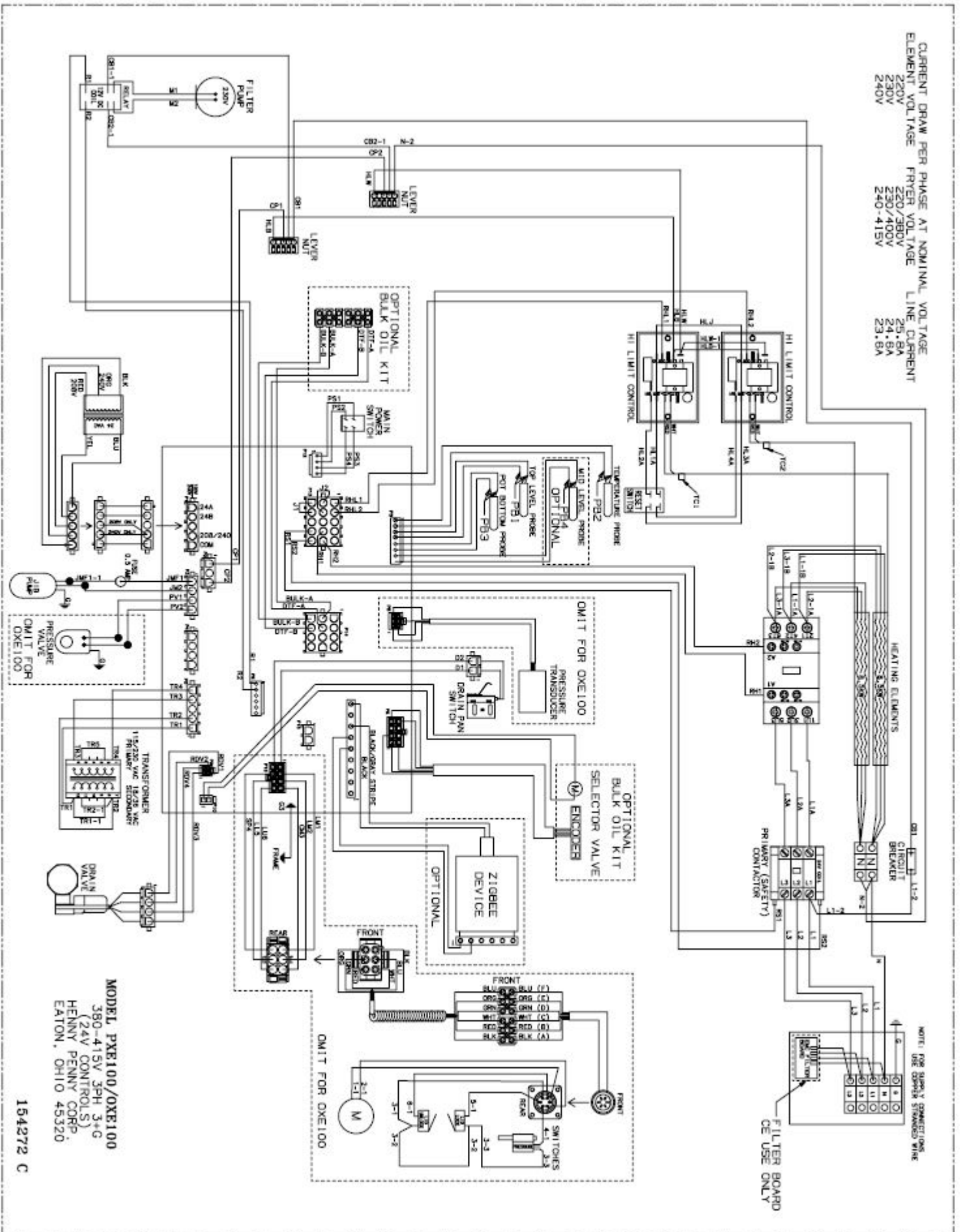

NOTE:
1. THIS DIAGRAM IS NOT AN ACTUAL DEPICTION
OF PLUMBING FITTINGS AND CONNECTIONS.

LEGEND
 ----- 1/2" DORMONT FLEXIBLE TUBE
 - - - - - 3/4" DORMONT FLEXIBLE TUBE

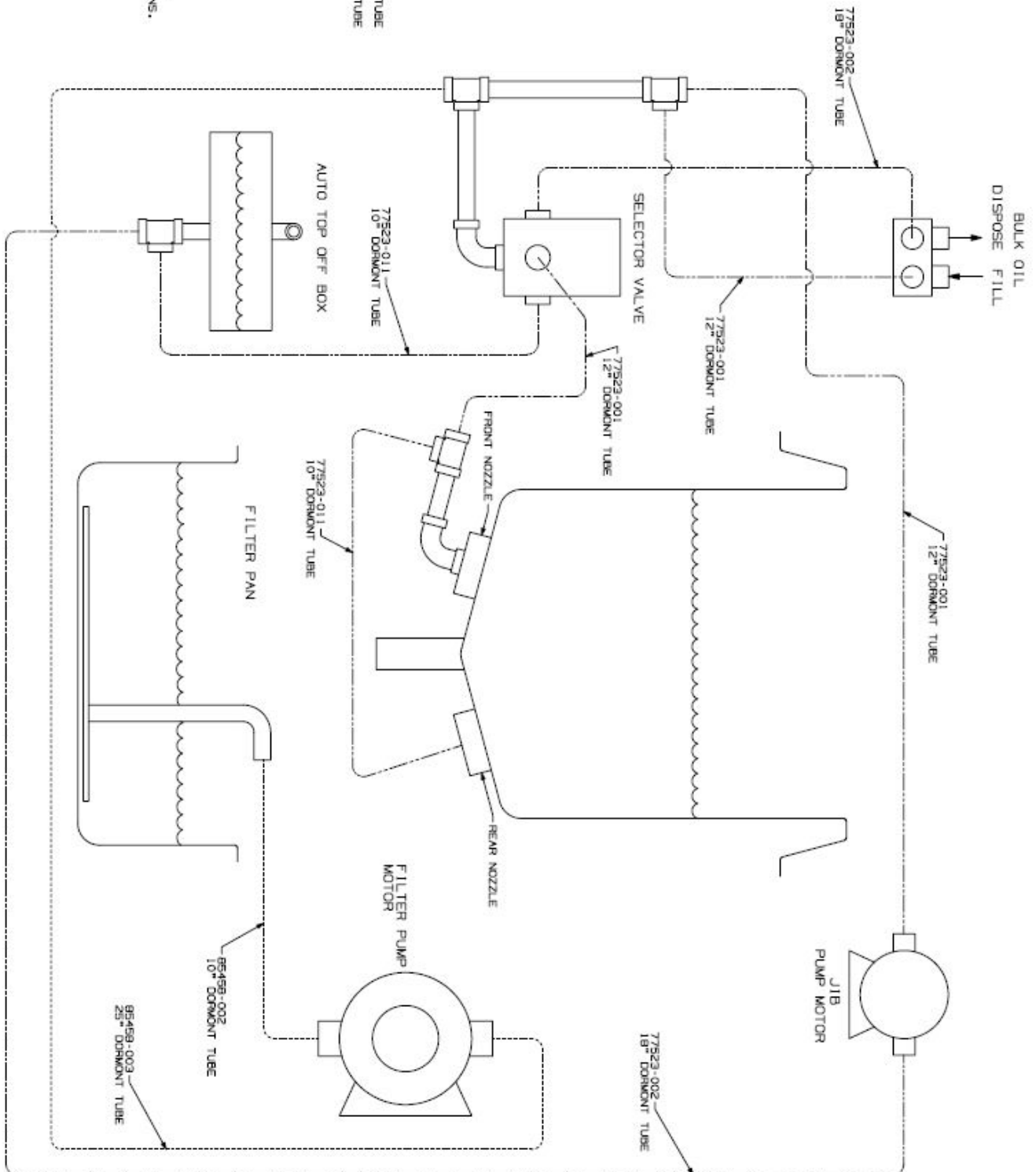

NOTE:
1. APPRAV IS NOT AN ACTUAL REPRESENTATION
OF PLUMBING FITTINGS AND CONNECTIONS.

LEGEND:
----- 1/2" DORMONT FLEXIBLE TUBE
..... 3/4" DORMONT FLEXIBLE TUBE

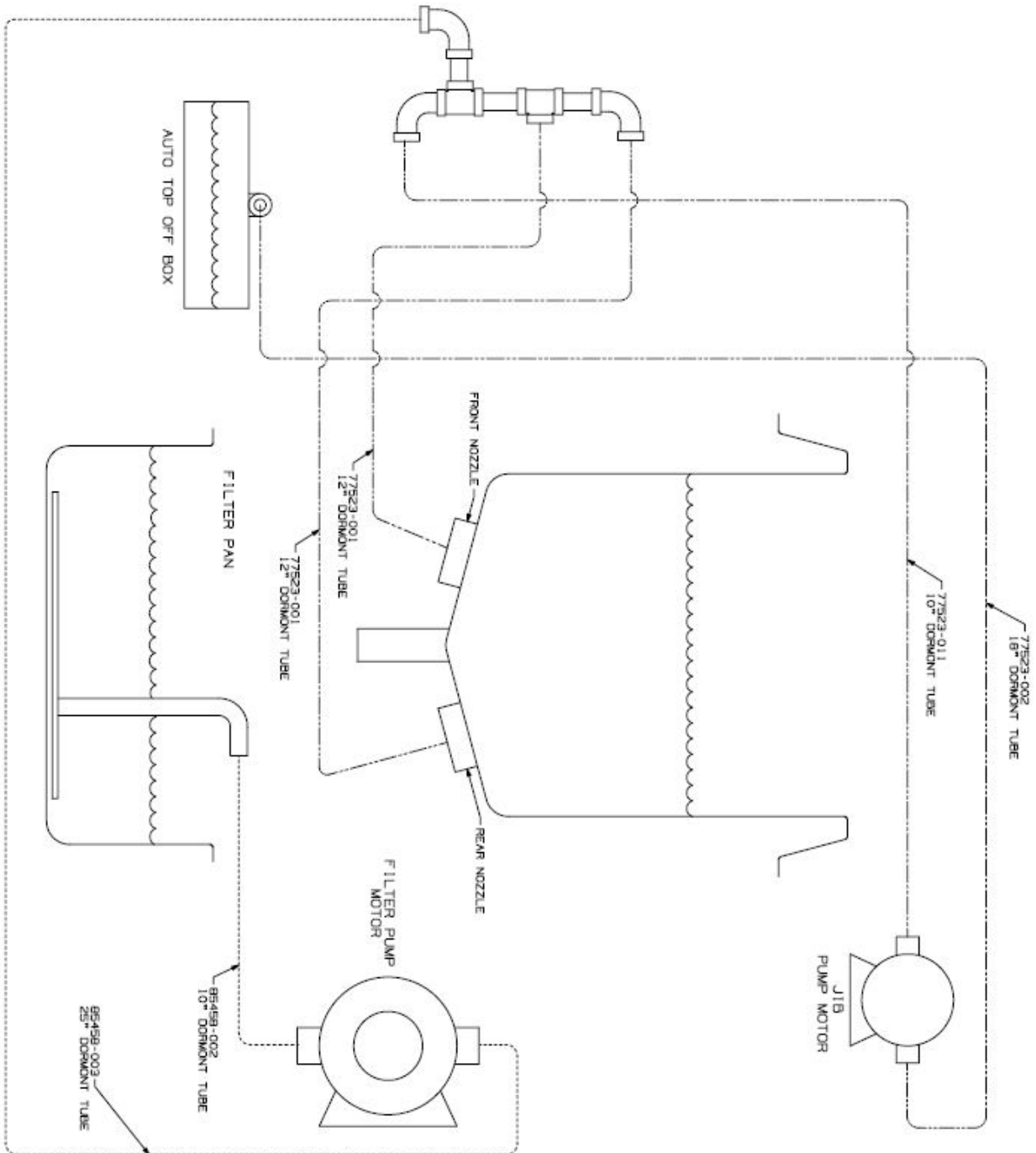

SECTION 5: PARTS SECTION

5-1 INTRODUCTION

This section lists the replaceable parts of the Henny Penny Velocity Series Pressure Fryer.

5-2 GENUINE PARTS

Use only genuine Henny Penny parts in your fryer. Using a part of lesser quality or substitute design may result in damage to the unit or personal injury.

5-3 WHEN ORDERING PARTS

Once the parts that you want to order have been found in the parts list, write down the following information:

Example:

Item Number 2
Part Number 60241
Description High Limit

From the data plate, list the following information:

Example:

Product Number 01100
Serial Number 0001
Voltage 208

5-4 PRICES

Your distributor has a price parts list and will be glad to inform you of the cost of your parts order.

5-5 DELIVERY

Commonly replaced items are stocked by your distributor and will be sent out when your order is received. Other parts will be ordered, by your distributor, from Henny Penny Corporation. Normally, these will be sent to your distributor within three working days.

5-6 WARRANTY

All replacement parts (except lamps and fuses) are warranted for 90 days against manufacturing defects and workmanship.

If damage occurs during shipping, notify the carrier at once so that a claim may be properly filed. Refer to warranty in the front of this manual for other rights and limitations.

5-7 RECOMMENDED SPARE PARTS FOR DISTRIBUTORS

Recommended replacement parts are indicated with A or B in the parts lists: A = parts to be stocked on service vans or trucks B = parts to be stocked at the distributor/KES location. Inventory on all other parts not identified, should be based upon usage in the territory. Please use care when ordering recommended parts, because all voltages and variations are marked. Distributors should order parts based upon comm voltages and equipment sold in their territory.

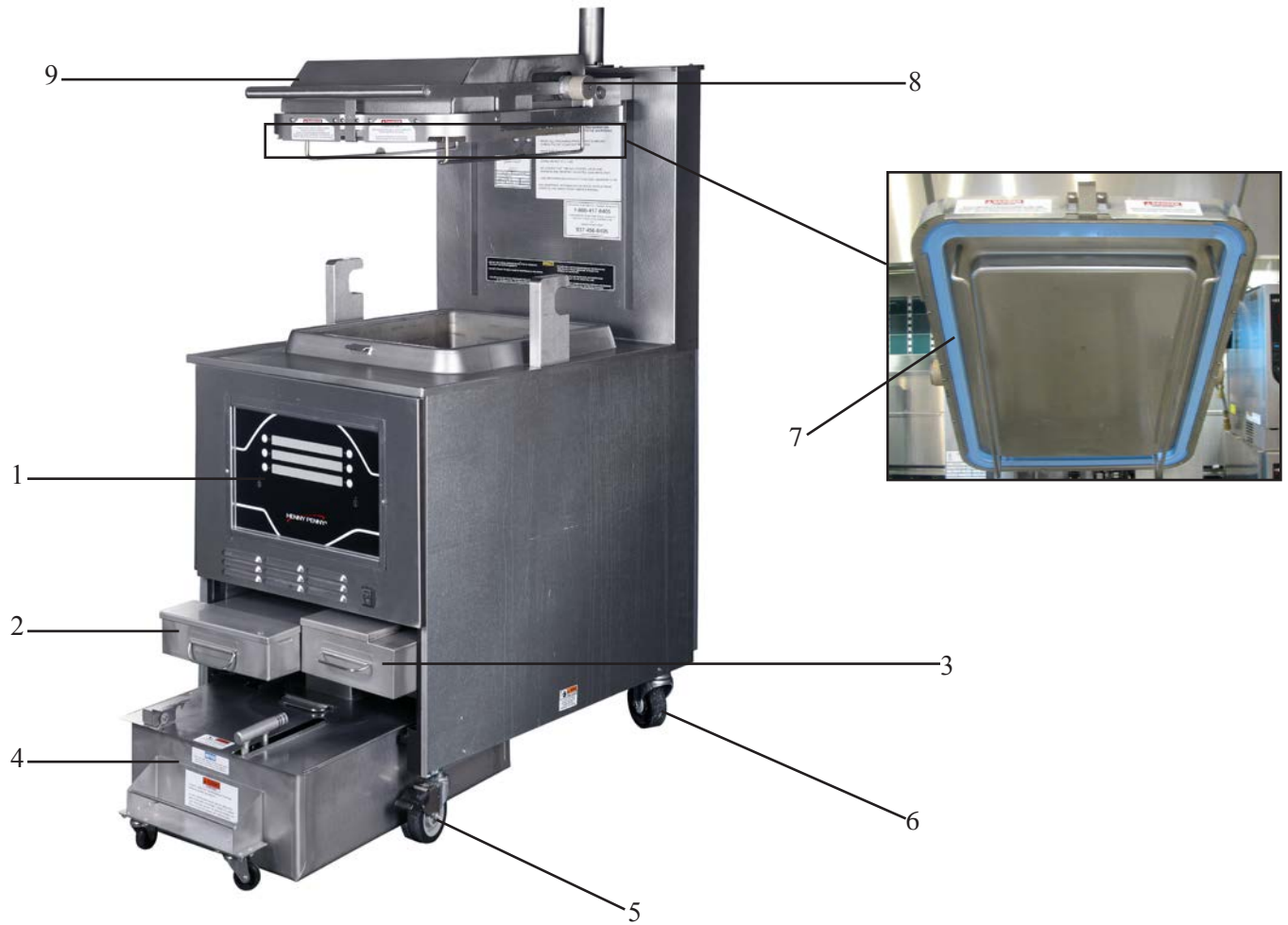

Item No.	Part No.	Description	Quantity
A 1	96804	ASSY-GM PXE100 CONTROL	1
*	96613	--DECAL-PXE101	1
*	26974	ASSY-SPEAKER	1
2	150598	FRESH OIL TANK	1
3	150836	CONDENSATION PAN.....	1
4	151783	ASSY-DRAIN PAN PFX	1
		--(see next page for breakdown)	
5	90227	CASTER-3.5 RIGID W/END BRAKE.....	2
6	35154	CASTER 4-INCH SWIVEL STEM	2
7	89664	GASKET-V STYLE FRYPOT LID	1
8	35227	ROLLER-LINKAGE SHAFT.....	2
9	152443	ASSY-LID AND COVER	1
*	140440	LID ROLLER KIT	1
*	94123	WELD ASSY-CARRIER	1
*	140440	LID ROLLER KIT	1
*	96800	ACCSRY GM PXE100	1

* = Not Shown / AR = As Required

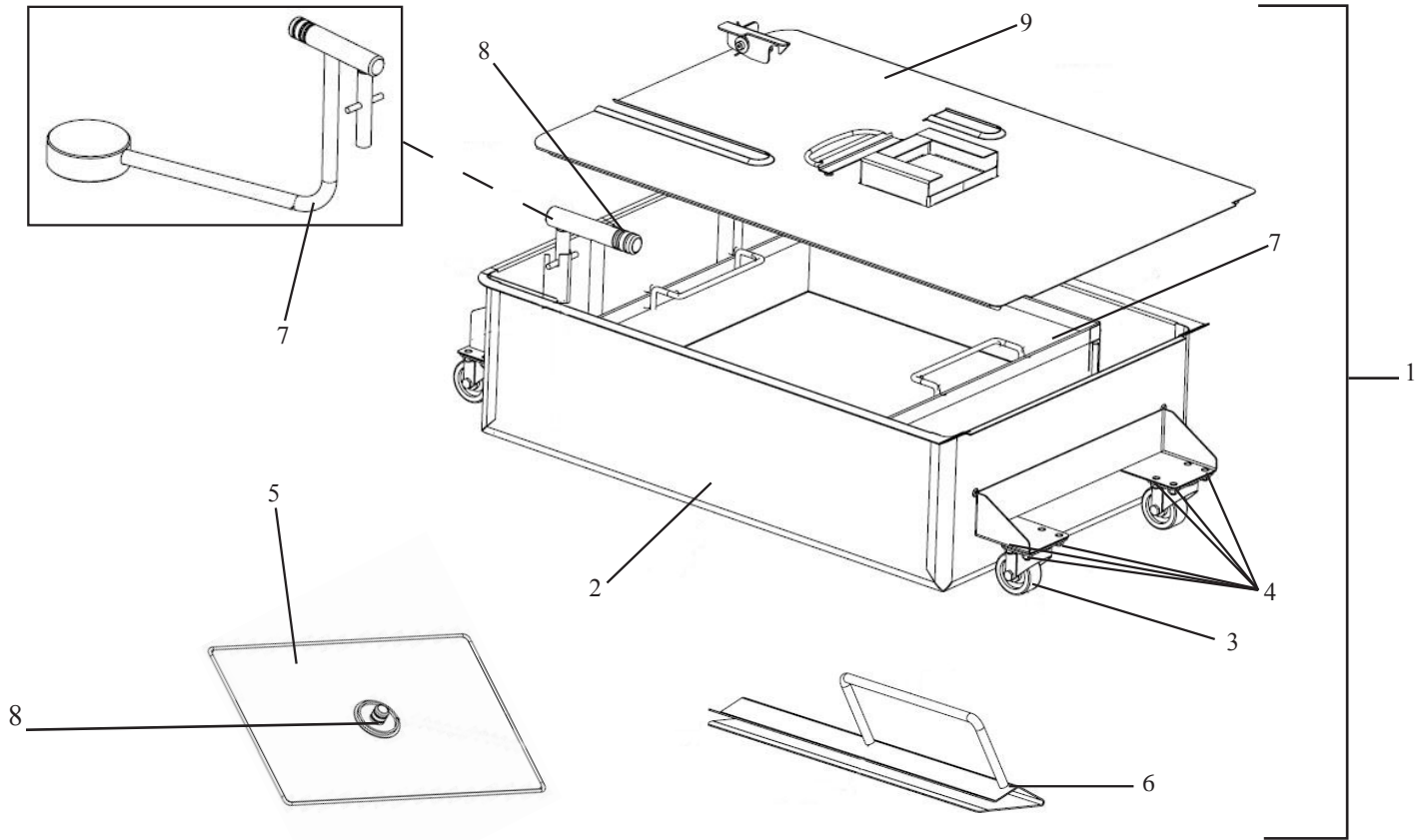

Item No.	Part No.	Description	Quantity
1	151783	ASSY-DRAIN PAN PFX	1
2	156492	-WELD ASSY-FILTER DRAIN PAN.....	1
3	19004	--CASTER-2 IN SWIVEL MTG PLATE.....	4
4	NS04-005	--SERRATED FLANGE LOCKNUT 1/4-20	16
5	92889	-WELD ASSY-FILTER SECTION	1
6	150739	-WELD ASSY-CARRIER CLIP	2
7	151819	-WELD ASSY-CRUMB CATCHER.....	1
A 8	86349	-O-RING -116 SUCTION LINE	5
9	94289	-ASSY-DRAIN PAN COVER PFX	1
B *	12102	-PHT FILTER ENVELOPES-100CT.....	AR
*	152204	-WELD ASSY-PNP UNIT.....	1

* = Not Shown / AR = As Required

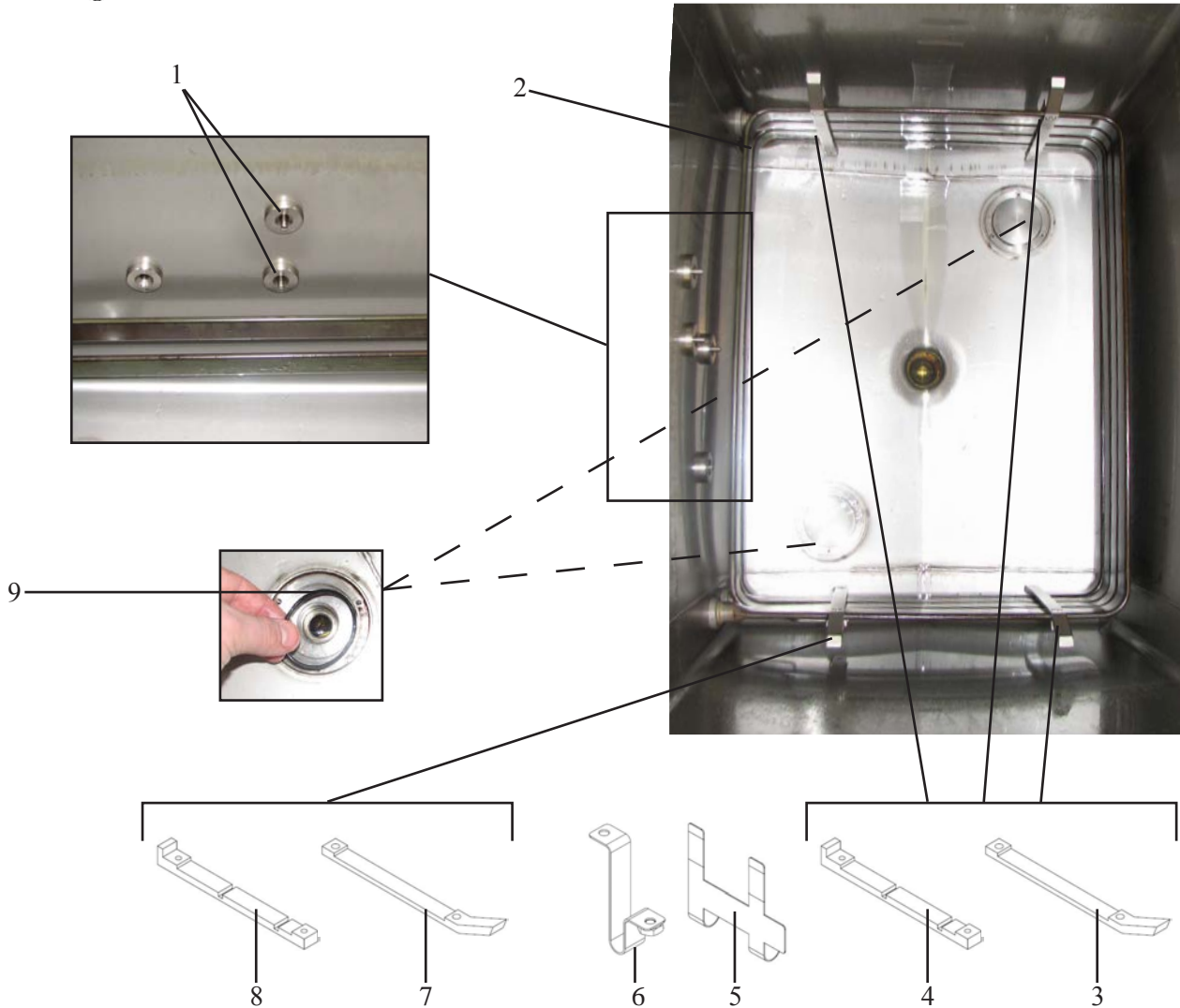

Item No.	Part No.	Description	Quantity
A 1	154252	ASSY-2 IN RTD PROBE	1
B 2	89225-001	ELEMENT-HEATING 8.5 KW (208V)	2
B 2	89225-003	ELEMENT-HEATING 8.5 KW (240V)	2
B 2	89225-004	ELEMENT-HEATING 8.5 KW (480V)	2
B 2	89225-005	ELEMENT-HEATING 8.5 KW (200V)	2
B 2	89225-006	ELEMENT-HEATING 8.5 KW (230V)	2
B 2	89225-007	ELEMENT-HEATING 8.5 KW (220V)	2
3	87119	SPREADER-ANGLED	3
4	87120	SPREADER-TAP PLATE	3
5	154736	CLIP-HIGH LIMIT	2
6	154866	WELD ASSY-HI LIMIT CLAMP CLIP	2
7	154839	SPREADER-HI LIMIT ANGLED	1
8	154840	SPREADER-HI LIMIT TAP PLATE	1
*	SC01-173	SCREW- #10-32 X 5/8 PH FHD SS	8
9	90085	O RING-CRUMB SWEEP.....	2

* = Not Shown / AR = As Required

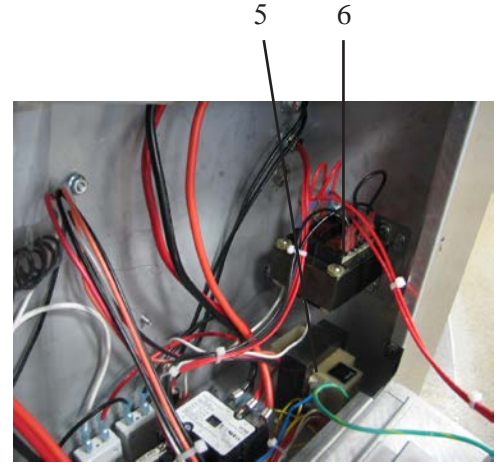
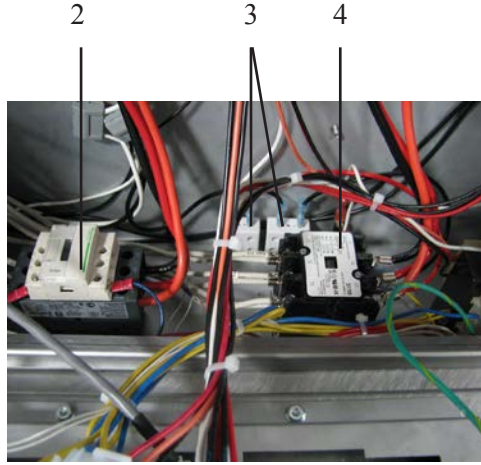
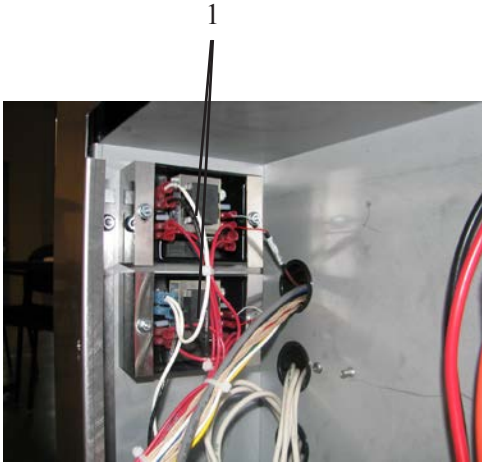

Item No.	Part No.	Description	Quantity
B 1	83581-002	CONTROL-WATLOW HIGH LIMIT (208V)	2
B 1	156985	CONTROL-WATLOW HIGH LIMIT (CE).....	2
*	84987	HL SWITCH-MOMENTARY SPLASH PROOF	1
B 2	51795	CONTACTOR-208/240 VAC COIL.....	1
B 2	65073	CONTACTOR-SQUARE D-24V.....	1
3	EF02-125	BREAKER-PUSH BUTTON RESET.....	2
*	EF02-104	FUSE HOLDER-20A 250V	2
*	EF02-105	FUSE 15 AMP	2
B 4	29509	CONTACTOR KIT - 24VAC	1
B 5	86087	ASSY-24V/240V 75VA TRANSFORMER.....	1
6	TS22-012	TRANSFORMER.....	1
*	ME90-008	P&B T92 RELAY 12VDC COIL 30AMP.....	1

* = Not Shown / AR = As Required

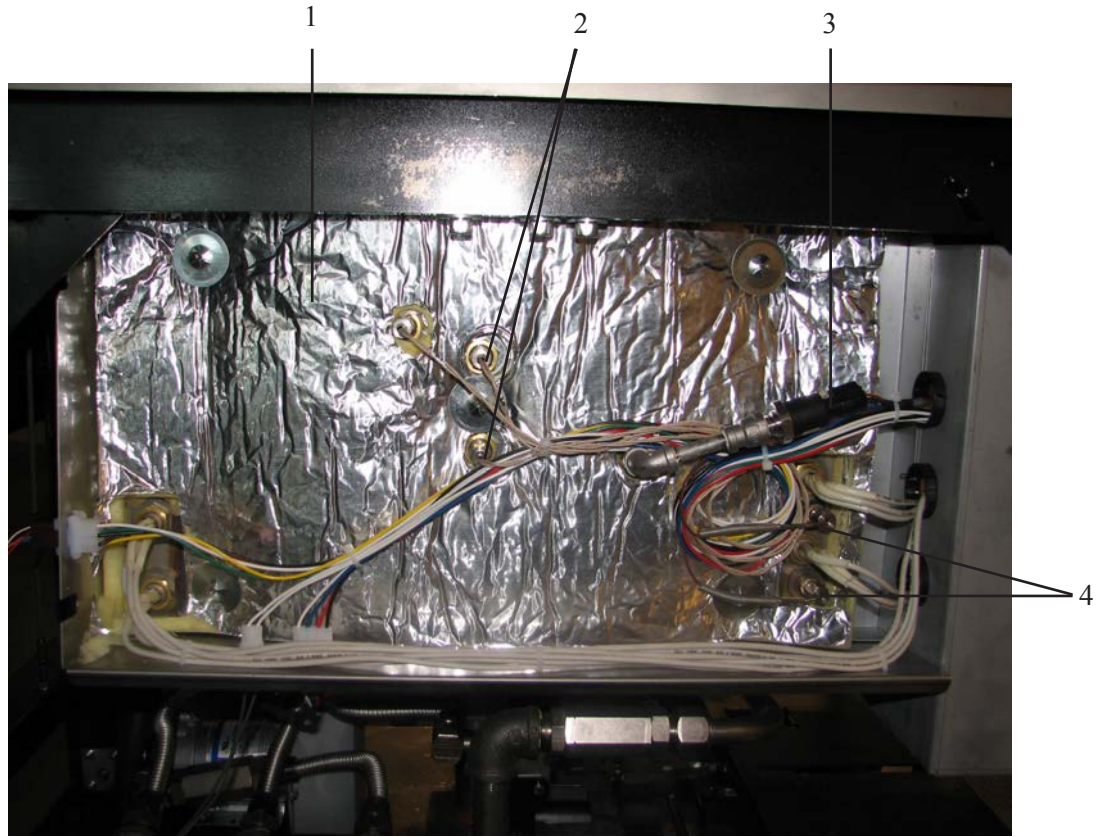

Item No.	Part No.	Description	Quantity
1	94229	INSULATION-POT LEFT SIDE	1
A 2	154252	ASSY-2 IN RTD PROBE	1
3	79213	TRANSDUCER-PRESSURE 30 PSI.....	1
A 4	93968	THERMOCOUPLE-HI LIMIT	2
A 4	156986	THERMOCOUPLE-HI LIMIT PROBE (CE)	2

* = Not Shown / AR = As Required

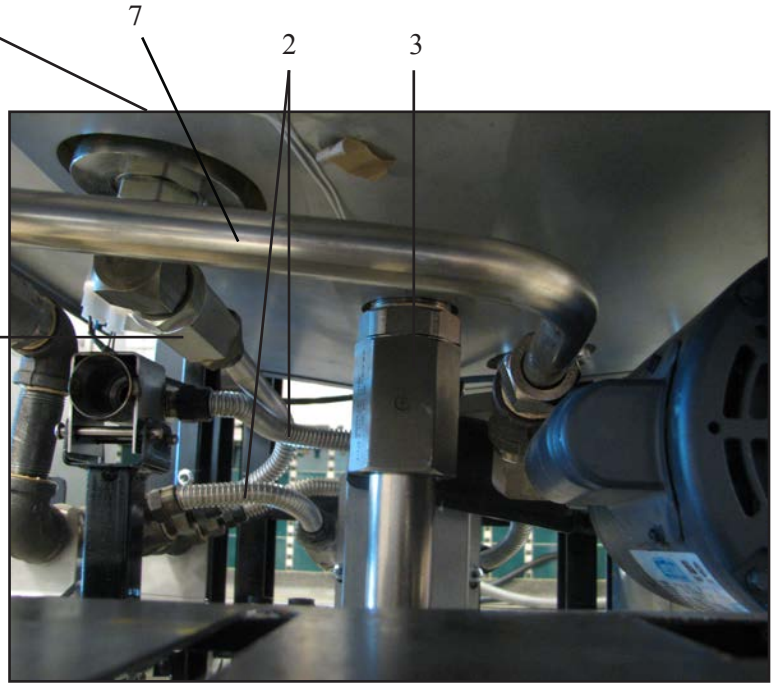
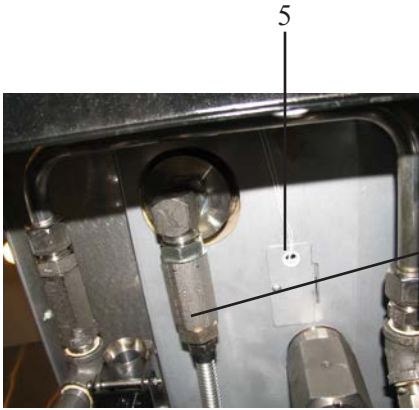
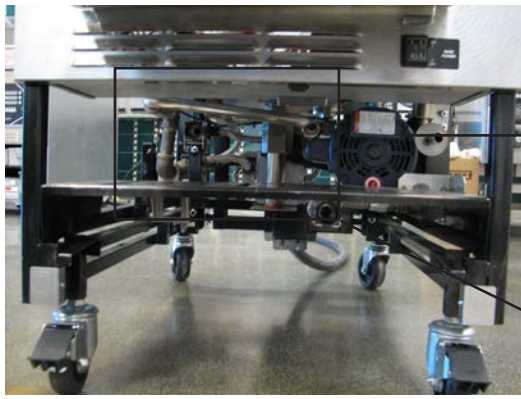

Item No.	Part No.	Description	Quantity
B 1	67583	MOTOR-1/2 HP FILTER PUMP (60Hz)	1
B 1	92850	MOTOR-1/2 HP FILTER PUMP (50Hz)	1
B *	64218	ASSY-FILTER PUMP-8 GPM.....	1
2	-----	FLEX LINES (see chart below for lengths and numbers)	
B 3	89780	VALVE-ACTR DRAIN W/ 4 PIN CONN	1
B 4	90506-001	VALVE-CHECK SAE 12 (max 200psi).....	AR
A 5	154252	ASSY-2 IN RTD PROBE	1
B 6	91700	ASSY-LH DRAIN PAN SW W/CONN	1
7	140444	FORM TUBE KIT	1
7	140446	FORM TUBE KIT (BULK OIL).....	1

Flex Line	
Part Number	Length
77523-002	12in.
77523-011	10in.

* = Not Shown / AR = As Required

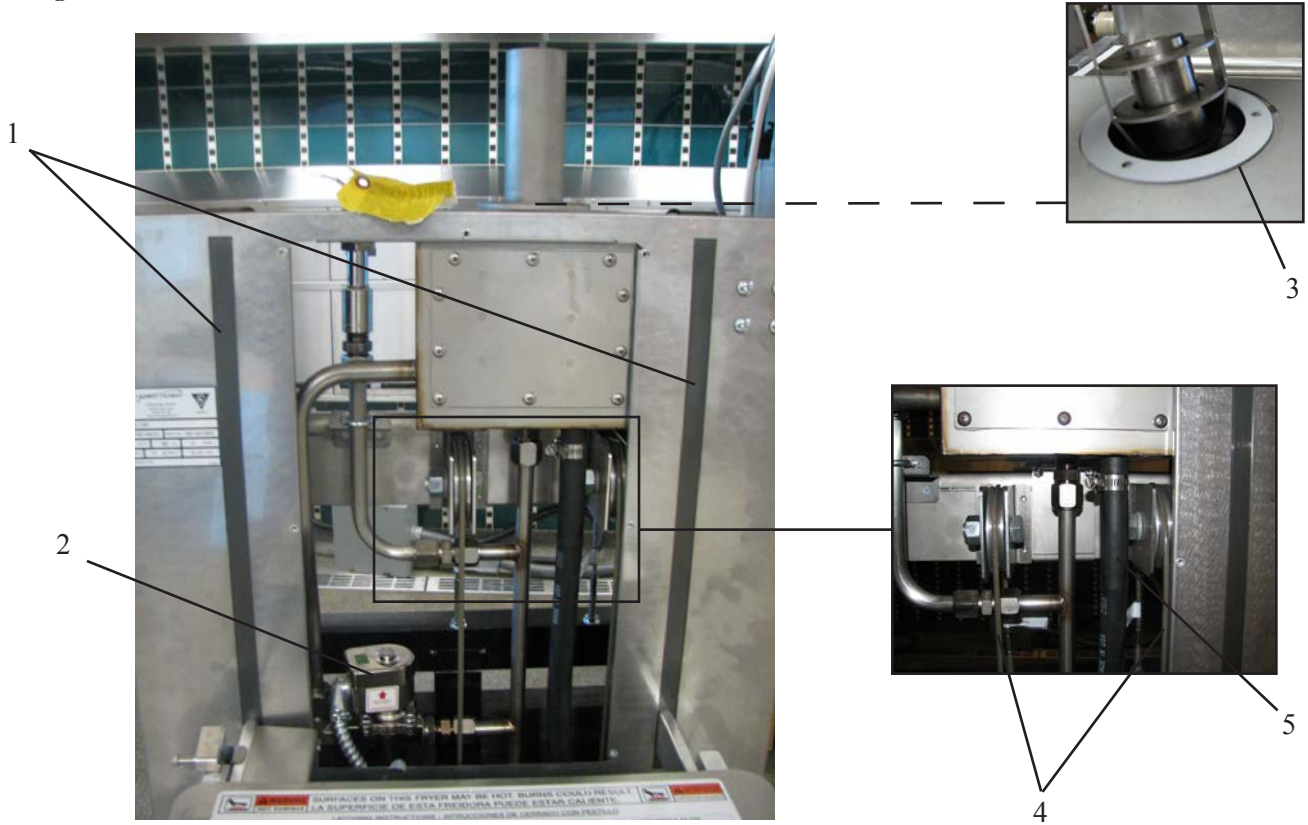

Item No.	Part No.	Description	Quantity
1	94256	SLIDE-SHROUD VERTICAL.....	2
B 2	85145	VALVE-208-240V 3/4IN SOLENOID.....	1
3	94941	GASKET-DEAD WEIGHT HOLDER	1
*	SC06-093	SCREW-10-32 X .500 KNURL PH HD	3
4	152276	ASSY-PULLEY CABLE AND LABEL	2
5	94377	HOSE-STEAM BOX CONDENSATE	1

* = Not Shown / AR = As Required



1

2

3

Item No.	Part No.	Description	Quantity
1	16903	DEAD WEIGHT-12 P.S.I.	1
2	152101	GASKET-STEAM BOX COVER.....	2
3	16918	ORIFICE - 12 PSI	3

* = Not Shown / AR = As Required

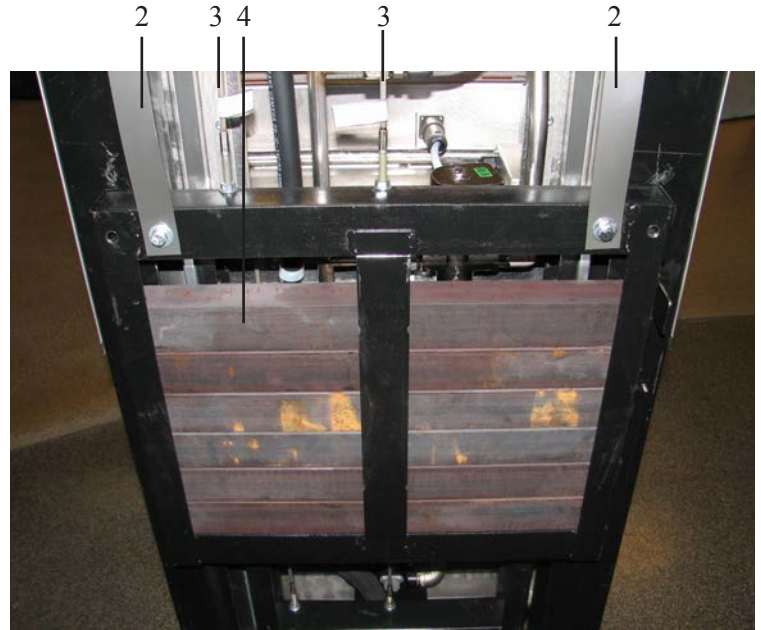

Item No.	Part No.	Description	Quantity
1	59742	ASSY - SAFETY RELIEF VALVE.....	1
2	94256	SLIDE-SHROUD VERTICAL.....	2
3	152276	ASSY-PULLEY CABLE AND LABEL	2
4	94259	COUNTERWEIGHT BAR	AR

* = Not Shown / AR = As Required

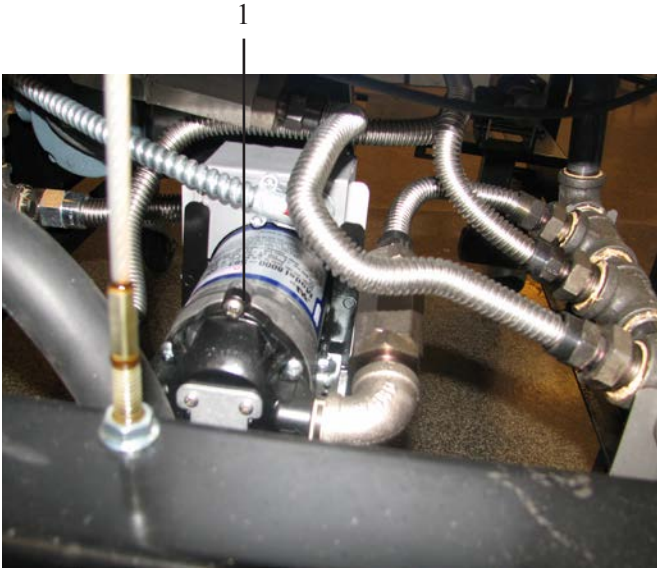

Item No.	Part No.	Description	Quantity
B 1	74583	PUMP-OIL TOP OFF 230V	1
B 2	90506-001	VALVE-CHECK SAE 12 (max 200psi).....	AR
3	-----	FLEX LINES (see chart below)	

Flex Line	
Part Number	Length
85458-002	10in.
85458-003	25in.

* = Not Shown / AR = As Required

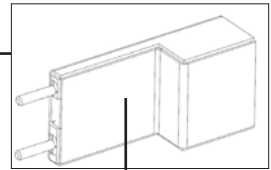
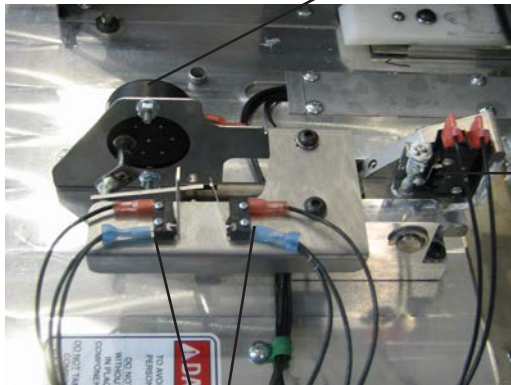
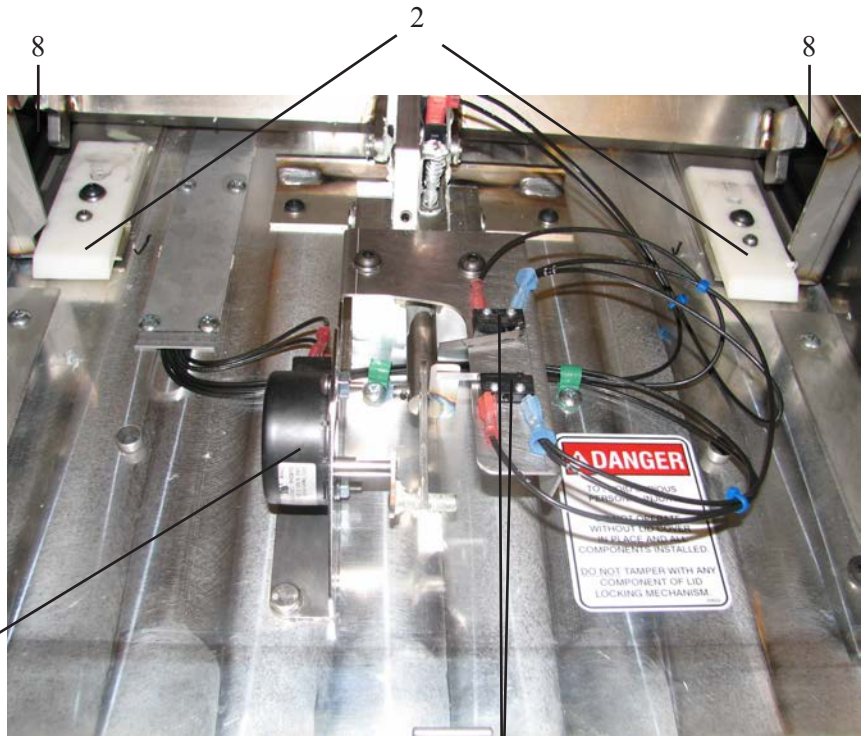
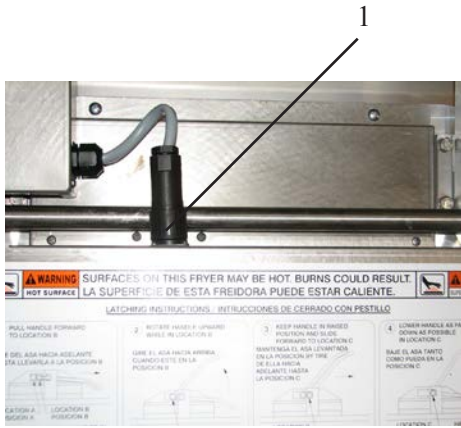

Item No.	Part No.	Description	Quantity
1	94825	ASSY-CABLE AND STRAIGHT SKT	1
2	49864	PAD-PRESSURE	2
B 3	93778	WELD ASSY-GEAR MTR 24VAC 60HZ.....	1
B 4	151463	SWITCH-LID LOCKING.....	2
5	151464	SWITCH-LID INTERLOCK	1
6	94971	ASSY-COILED LID CORD.....	1
7	94322	WELD ASSY-LID WIRING RACEWAY	2
8	93222	FILLER-CAM SLIDE.....	2

* = Not Shown / AR = As Required



**Henny Penny Corporation
P.O.Box 60
Eaton, OH 45320**

**1-937-456-8400
1-937-456-8402 Fax**

**Toll free in USA
1-800-417-8417
1-800-417-8434 Fax**

www.hennypenny.com