

Hickory Rotisseries

Models: N/7.7 G



Machine Type	N/7.7 G
Total Power Rating	160,000 or 180,000 BTU
Burner / Spits	4 or 5 Burners with 14 Spits
Gas Category	Natural Gas, LPG
Fittings	4 Infra-Red Gas Generators / 1 pipe burner
Ignition	4 or 5 Electronic Ignitors
Delivery Date:	Final Inspection:

Table of Contents

1.0 Installation	3
1.1 General Information	4
1.2 Description of the Data Plate	4
1.3 Machine Dimensions in inches and mm	5
1.4 Gas Conversion and Adjustment Instructions	8
1.5.1 Gas Conversion and Adjustment Instruction for Show Burner (SB) and Woodburning Module (WB)	8
1.5 Verification for use with Natural Gas	8
1.6 Gas Flow Table (Consumption)	9
1.7.1 Volumetric Method to Verify the Flame Setting, Mathematical	9
1.7 Orifice Diameters, Electrode Gap Settings, and Air Intake Settings	10
1.8 Changing Gas Orifices	11
1.8.1 Changing the Gas Orifice - Gas Generators	11
1.8.2 Changing the Gas Orifice - Pipe Burner for SB and WB	12
1.9 Ignition Cycle	13
1.9.1 Adjusting the Ignition Electrode	13
1.10 Checking the Connected Gas Pressure (Nominal Pressure)	15
1.11 Maintenance, Response to Technical Problems	15
1.11.1 Reasons for problems and solutions	16
1.12 Spit Drive Mechanism	17
1.13 Testing or Checking for Safety	18
1.14 Description of the Electrical Connection	18
1.15 Electrical Diagram	19
1.16 Parts List for N/7.7G	23
1.17 List of Additional Parts for N/7.7G with Show Burner (SB)	25
1.18 List of Additional Parts for N/7.7G with Woodburning Module (WB)	25
1.19 Parts List for Woodburning Module (WB)	25

1.0 Installation Instructions

- a. When installing these units, it is important to comply with the most recently established rules and regulations as deemed pertinent by the local and national electrical, gas, ventilation, sanitation, and fire codes. These units are classified by Underwriters Laboratories, Inc. as Gas-Fired Food Service Equipment in accordance with American National Standards Institute ANSI Z83.11b-1991, Gas Food Service Equipment - Ranges and Unit Boilers.
- b. These gas units must not be directly connected to a gas flue or exhaust. However, the units may only be operated in conjunction with a canopy type exhaust hood.
- c. The room where the units are being installed must be ventilated in accordance to the valid codes and regulations.
- d. The units are to be installed securely and horizontally. The units may be installed on combustible floors. The units may be installed on adjustable legs or on casters (wheels).
- e. The minimum clearance to the rear or side walls must be 3 inches. It is also important to insure that the bottom of the units is kept clear so that proper ventilation or air exchange can occur.
- f. Normally, the units will be sent to the operator already set up for the particular type of gas available at their location. However, unless otherwise specified, the units will be set up for natural gas use. Before installing and using the units for the first time, it is important to make sure that the gas type and pressure indicated on the data plate matches the type of gas available in the location. Should this not be the case, it is imperative to change or convert the units to the needed gas type.
- g. The units must be fitted with the manual shut-off gas cock (valve) supplied with the machine. This manual valve is needed to shut off the gas to the machine during maintenance work, repairs, and if the unit needs to be disconnected for any reason.
- h. A gas regulator is also supplied with the machine. This component is needed so that the appropriate gas pressure can be set and insure an optimum operation of the unit.
- i. Depending on local codes or if deemed necessary, a gas filter may also be required.

1.1 General Information

The Operating Instructions are to be given to the operator of the rotisserie. All unit operators are to be familiar with the functions of the rotisserie.

The Operating Instructions should be kept in a location close to the rotisserie. It should be easily recognizable and easily accessible.

These rotisseries can be used with both natural and LPG gases. The rotisseries can be converted or adjusted to any type of the locally distributed natural and LPG gases.

It is recommended that a repair and maintenance contract be signed with the manufacturer's agent, distributor, or service agency.

1.2 Description of the Data Plate

HICKORY INDUSTRIES, INC. COMMERCIAL COOKING APPLIANCES NORTH BERGEN, NJ 07047	
MODEL <input type="text" value="N/7.7 G"/>	SERIAL NO. <input type="text"/>
MOTOR: 110 - 115 VOLTS 60 CYCLE AC CURRENT 1/2 HP SINGLE PHASE 5.7 RPM	
BURNERS	<input type="text" value="4 / 1"/>
LISTED  69D6	GAS INPUT PER BURNER <input type="text" value="40,000 / 20,000"/> BTU/H
	MANIFOLD PRESSURE <input type="text" value="5.5"/>
	TYPE OF GAS <input type="text" value="NAT"/>
	MFG. DATE <input type="text"/>
MINIMUM INSTALLATION CLEARANCE SIDE: 6 INCHES BACK: 6 INCHES MAXIMUM LAMP WATTAGE: 150 WATTS FOR INSTALLATION ON A COMBUSTIBLE FLOOR <small>Gas-fired Food Service Equipment Classified by Underwriters Laboratories Inc. In accordance with American National Standards Institute ANSI Z 83.11b-1991, Gas Food Service Equipment-Ranges and Unit Boilers</small>	

HICKORY INDUSTRIES, INC. COMMERCIAL COOKING APPLIANCES NORTH BERGEN, NJ 07047	
MODEL <input type="text" value="N/7.7 G"/>	SERIAL NO. <input type="text"/>
MOTOR: 110 - 115 VOLTS 60 CYCLE AC CURRENT 1/2 HP SINGLE PHASE 5.7 RPM	
BURNERS	<input type="text" value="4 / 1"/>
LISTED  69D6	GAS INPUT PER BURNER <input type="text" value="40,000 / 20,000"/> BTU/H
	MANIFOLD PRESSURE <input type="text" value="11"/>
	TYPE OF GAS <input type="text" value="LPG"/>
	MFG. DATE <input type="text"/>
MINIMUM INSTALLATION CLEARANCE SIDE: 6 INCHES BACK: 6 INCHES MAXIMUM LAMP WATTAGE: 150 WATTS FOR INSTALLATION ON A COMBUSTIBLE FLOOR <small>Gas-fired Food Service Equipment Classified by Underwriters Laboratories Inc. In accordance with American National Standards Institute ANSI Z 83.11b-1991, Gas Food Service Equipment-Ranges and Unit Boilers</small>	

WARNING!

This unit must be installed and connected in accordance to the latest regulations and can only be operated in conjunction with forced ventilation or exhaust hood.

This unit has been designed for professional use only and may only be installed or repaired by licensed service agencies!

Before installing or using this equipment, read these instructions!

1.3 Machine Drawings and Dimensions

The following drawing of the Front View, Side View, and Top View indicate where the dimensions are taken and should be used to plan the installation of the units.

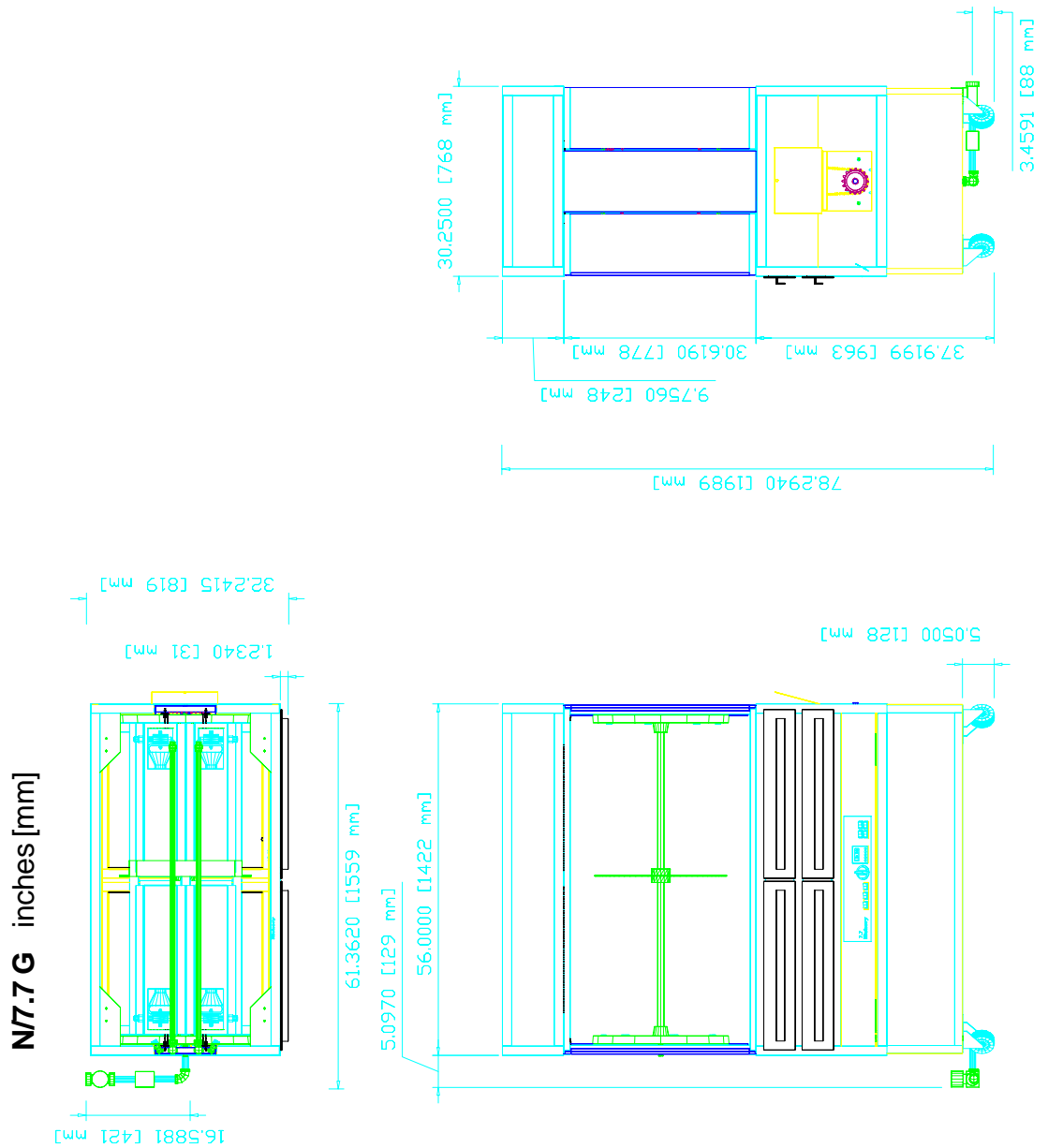

7.7 G with Show Burner inches [mm]

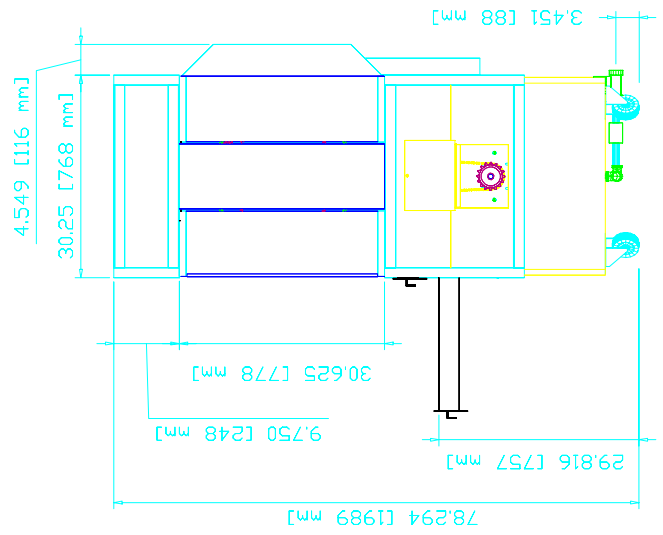
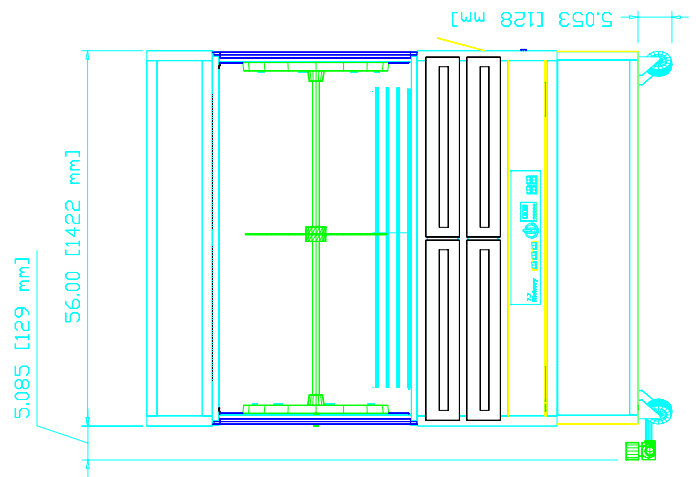
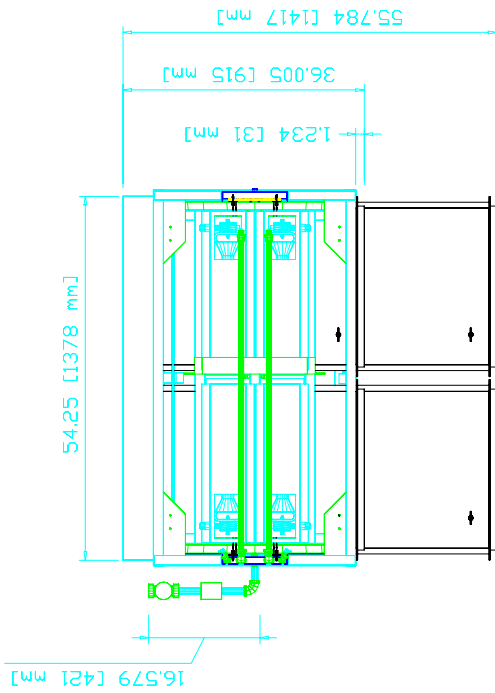

N/7.7 G with separate hearth burner inches [mm]

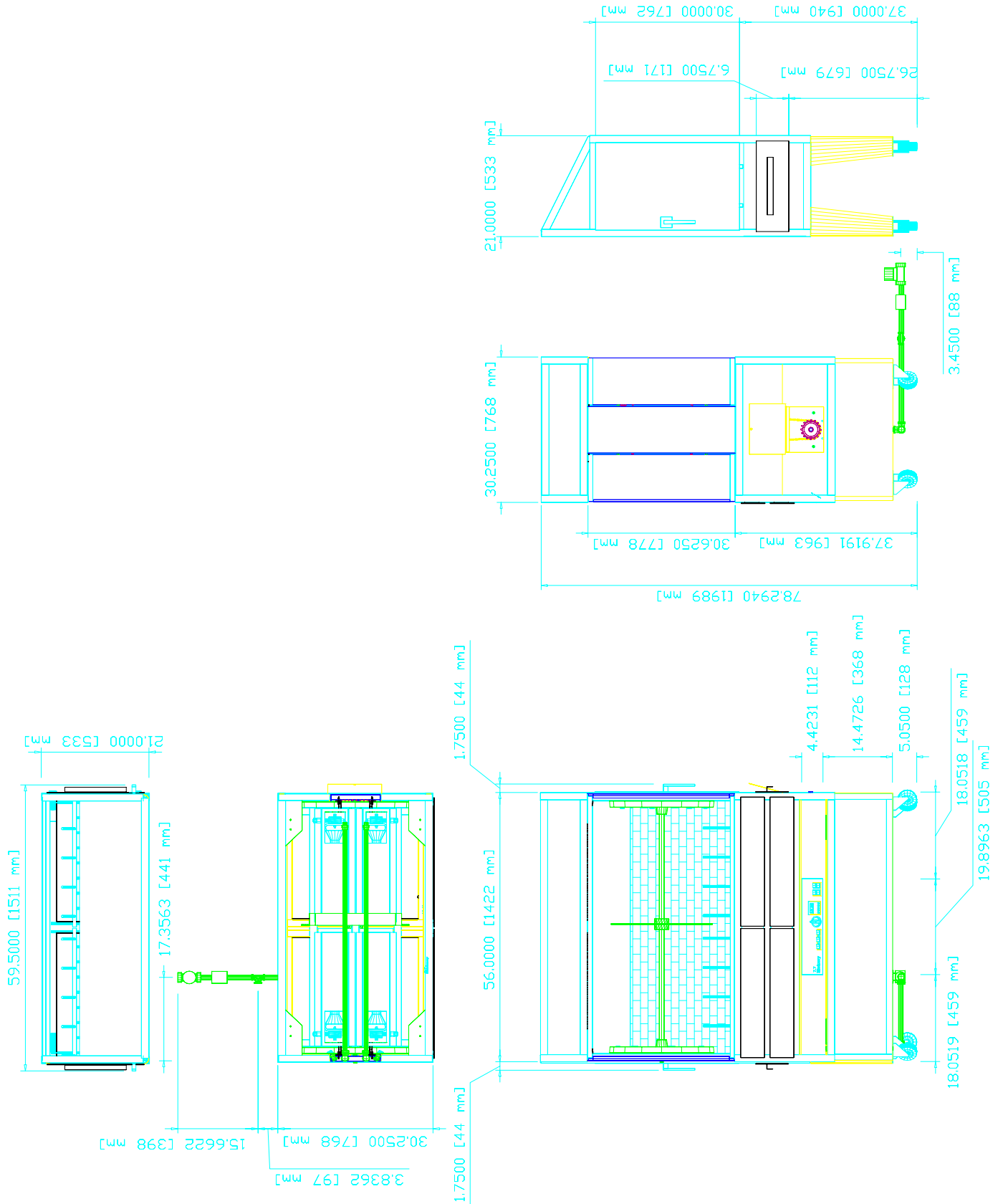

1.4 Gas Conversion and Adjustment Instructions

Before converting or adjusting the machine to another type of gas, it is imperative that the manual gas cock be turned to the "off" position. The electrical power to the machines should also be turned off. When converting the gas generators for use from one type of gas use to another, the gas orifice (or injector) must be changed according to the table on page 9. In addition, the spring in the pressure regulator supplied with the unit must be changed so that it can operate at other gas pressures. Springs for the regulator can be ordered from Hickory Industries.

1.4.1 Gas Conversion and Adjustment Instructions for Show Burner (SB) and Woodburning Module (WB)

Before converting or adjusting the machine, it is imperative that the manual gas cock be turned to the "off" position. The electrical power to the machines should also be turned off. When converting from one type of gas to another, the gas orifice (or injector) and the primary air adjustment must be changed according to the table on page 9. In addition, the spring in the pressure regulator must be changed as previously explained.

1.5 Verification for use with Natural Gas

The flame setting for each gas generator and for the pipe burner can be confirmed by using the volumetric method in conjunction with the main gas meter. Each burner has an independent solenoid gas valve. Each valve is controlled by its own, independent Gaslite spark ignition module. The amount of gas flowing through the valves can not be adjusted manually; there is only an "on" or "off" position.

To carry out this verification procedure, it is necessary to obtain the heating value (BTU/ft³) of the local gas from the local gas company. **A variation in the heating value of the local gas from that on the table (1.6) will result in a variation of the power output of the unit!**

If the measured gas volume does not correspond to the values in the following table (1.6), the items which should be checked are:

- A. The incoming (connected) gas pressure while all burners and all other appliances in the location are operational.
- B. If the gas pressure is correct, it must be verified that the proper size gas orifices are in place (see page 9).

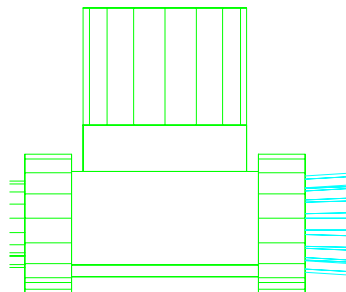

Solenoid Valve

1.6 Gas Flow Table (Consumption)

Gas	Heating Value in BTU/ft ³	Gas Flow per Burner (40,000 BTU) in ft ³ /hr High Flame Setting
Natural	1040	38.50
Propane	2500	16.00
Butane	2500	16.00

1.6.1 Volumetric Method to Verify the Flame Setting, Mathematical

WARNING! No other gas equipment can be in operation during this procedure.

Calculation of flow rate E in ft³/hour

$$Q = \frac{E}{H_i}$$

Q = Flow rate in ft³/time

E = High Flame Power setting in BTU/hr

H_i = Heating value in BTU/ft³

Thus, for natural gas:

$$Q = \frac{40,000 \text{ BTU/hr}}{1040 \text{ BTU/ft}^3} = 38.50 \text{ ft}^3/\text{hr} = 0.64 \text{ ft}^3/\text{min.}$$

$$Q = 0.64 \text{ ft}^3/\text{min.}$$

Calculation of the natural gas needed in 1 hour by a 7.7G (4 burners) at full power:

$$Q = 38.50 * 4 = 154 \text{ ft}^3/\text{hr} = 2.56 \text{ ft}^3/\text{min.}$$

The time and the flow measurements should be taken at the gas (flow) meter with a chronometer (stop watch).

To run the test, open the manual gas cock valve, start up the unit according to the start-up instructions.

Allow the unit to pre-heat (burn) for 10 to 15 minutes. Verify that the flow rate is calibrated to the appropriate flow rate indicated in the table.

NOTE: This mathematical calculation was done assuming a #38 orifice size and a connected gas pressure of 5.5" with an infra-red generator. The actual flow rate will vary depending on the Heating Value of the local gas and on the set gas pressure!

1.7 Orifice Diameters, Electrode Gap Settings, and Air Intake Settings
Type N/7.7 G

Gas/Pressure	Orifice Size	Electronic Ignition	
inches W.C.	Ø in drill size	Electrode Gap	
Natural / 5.5"	#38	1/8" Between rods 1/8" Between rods and Burner surface	
Propane / 11"	#51	1/8" Between rods 1/8" Between rods and Burner surface	
Butane / 11"	#51	1/8" Between rods 1/8" Between rods and Burner surface	

Type N/7.7 G with Show Burner or Woodburning Module

Gas/Pressure	Orifice Size	Electronic Ignition	Primary Air Intake
inches W.C.	Ø in drill size		in inches
Natural / 5.5"	#40	1/8" Between rod and Pipe Burner	1/8"
Propane / 11"	#55	1/8" Between rod and Pipe Burner	1/8"
Propane / 11"	#55	1/8" Between rod and Pipe Burner	1/8"

1.8 Changing Gas Orifices

1.8.1 Changing the Gas Orifice - Gas Generators

The 7.7 Gas unit has four infra-red gas generators. In older models, these generators used **ceramic** radiating plates. All new 7.7 units use **Inconel (Metal alloy)** radiating plates. All four burners are interchangeable with a minor burner inlet pipe position modification.

1. When looking from the very top of the rotisserie downward, you will see the following:

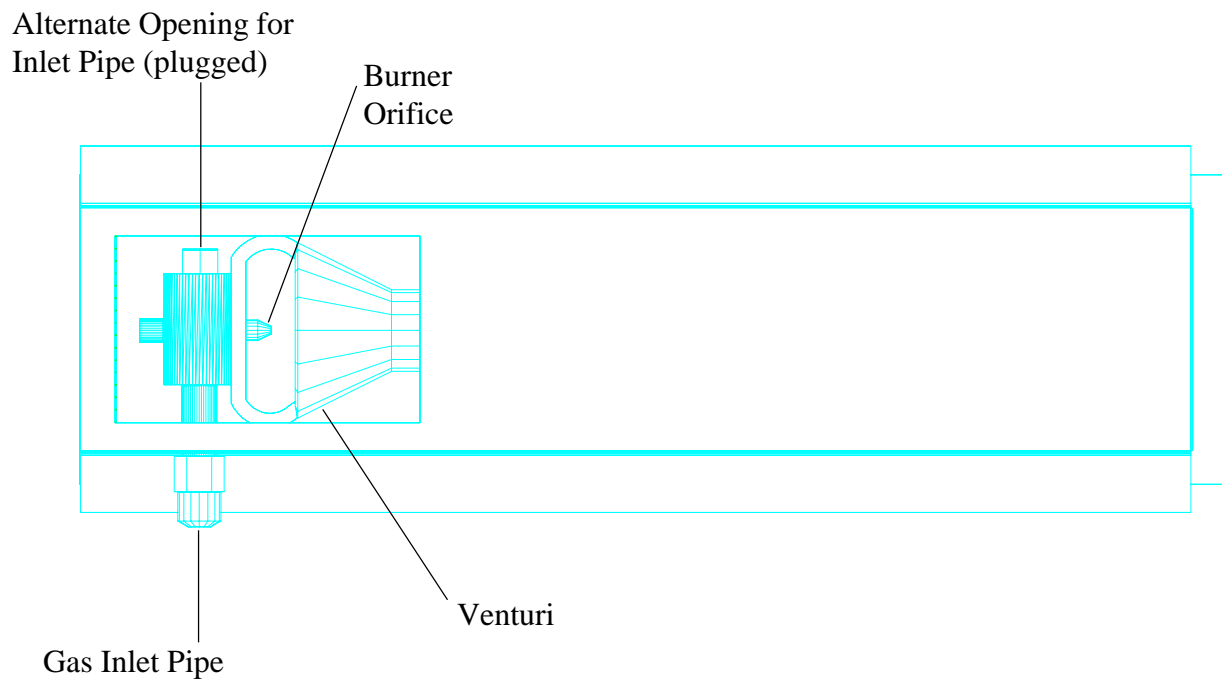

Top View Gas Generator

2. The burner orifice can be removed and replaced using a 7/16" wrench. The orifice must be sealed and tightly in place.

1.8.2 Changing the Gas Orifice - Pipe Burner for SB and WB

1. Remove the left hand drip pan and loading tray.
2. Unscrew and remove the metal cover to expose the venturi.
3. The venturi tube is on the inlet side to the pipe burner.
4. On the venturi, loosen the lock nuts (7/8" wrench) and then move the nut and the air intake cap all the way to the top of the nipple.
5. With a 3/4" wrench, loosen the nipple so that it can be removed from the venturi.
6. With the nipple/orifice assembly off, separate the main orifice from the nipple with a pipe wrench or a pair of pliers.

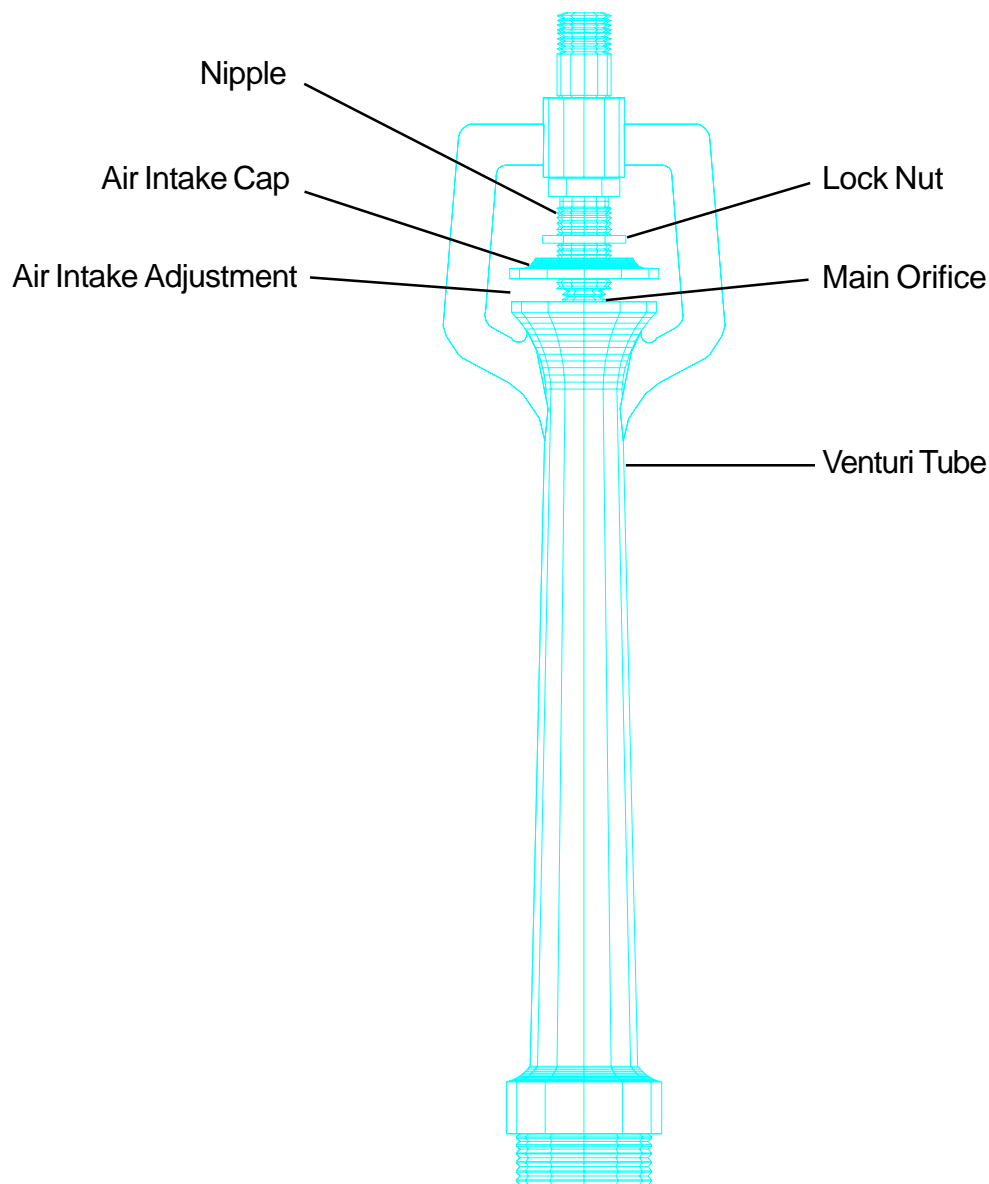

Venturi Assembly

Re-assemble all of the components with the new orifice. Make sure that the proper air intake adjustment is made for the new type of gas (according to the table on page 9). The flames should be blue in color, must be stable, and must not "lift off" the burner.

1.9 Ignition Cycle

In order to start the cooking cycle, the burners must be ignited. The ignition cycle will start only when the following procedure is followed:

- a. The "HEAT" switch is turned to "on".
- b. The individual burner switches are turned to "on".
NOTE: The SB and WB pipe or rear burners can be shut off using an unmarked toggle switch located on the upper side of the control panel. Make sure that this is in the desired position.
- c. A cooking temperature must be set on the thermostat (i.e. 450°F).
- d. The cooking timer must be activated (see Operating Instructions).

Once these steps are completed, the unit will call for heat and the ignition cycle will be activated. The ignition system will cause sparking on the ignition electrode. Once the burner is lit by the spark, the flame of the burner will heat the sensing prong on the ignition electrode sending a signal back to the ignition module. This signal indicates that a spark is no longer needed and that the solenoid gas valve must stay open. When the cooking temperature is reached, as sensed by the thermocouple attached to the thermostat, the electrical power to the ignition modules will be cut off, shutting down the ignition module and the burners. When the temperature drops below the set point, electrical power is sent to the ignition system once again, thus starting the ignition cycle all over. The system will cycle on and off as needed to maintain the set cooking point.

The ignition modules will attempt to ignite their corresponding burners three times. If the burners fail to light after three tries, the module will lock-out, shutting down all gas flow and further sparking.

In order to start the ignition cycle after a lock-out, the heat switches and individual burner switches must be turned "off" and "on" again. This may have to be done several times when starting up the unit for the first time due to air in the gas lines.

1.9.1 Adjusting the Ignition Electrode

The ignition electrodes are adjusted for an optimum ignition cycle before the unit leaves the factory. If for some reason the electrodes need adjusting (i.e. if one takes a hit with a spit), it can be done as follows.

1. To reach the ignition electrode, open the sliding glass doors and remove all spits.
2. Each electrode is attached to the main body of the machine with an 8/32" screw and nut. It is important that this screw make solid metal to metal contact between the electrode casing and the body of the rotisserie. This metal to metal contact is what acts as a grounding conductor for the grounding prong on the ignition electrode.
3. During the ignition process, a solid blue/yellow spark should travel between the tip of the two electrode prongs.

Ignition Wire Connection

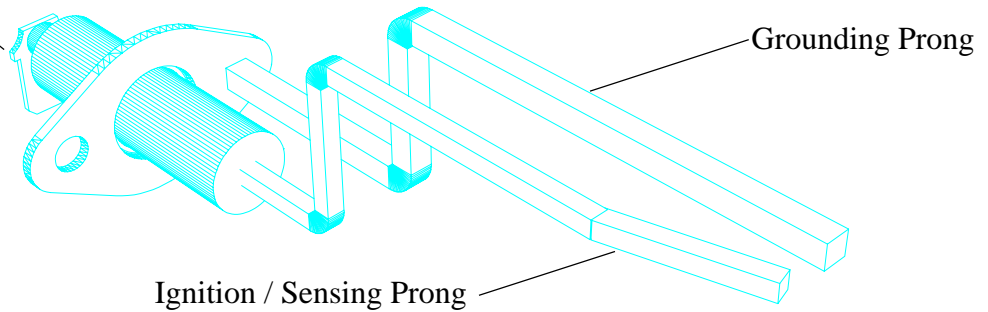

Ignition Electrode

4. Make sure that the distances between the prongs and the surface of the burner are about 1/8".
5. If the distances between the prongs and/or the burner surface are too great, the unit may spark but not ignite the burner.
6. If the distance between the prongs and the burner surface are too close, contact may occur causing a short-circuit and preventing any ignition. Note that the INCOLOY (metal) surface of the burners will warp downward once the burner heats up . If this happens and the surface does make contact with the electrode prongs, the burner will shut off.
7. When adjusting the prongs, make sure to support the base of the prong with one pair of pliers and adjust the tip of the prong with another pair. This will prevent breakage of the ceramic casing of the sensing prong. If the ceramic casing does break, it will cause erratic ignition problems and the electrode will have to be replaced.

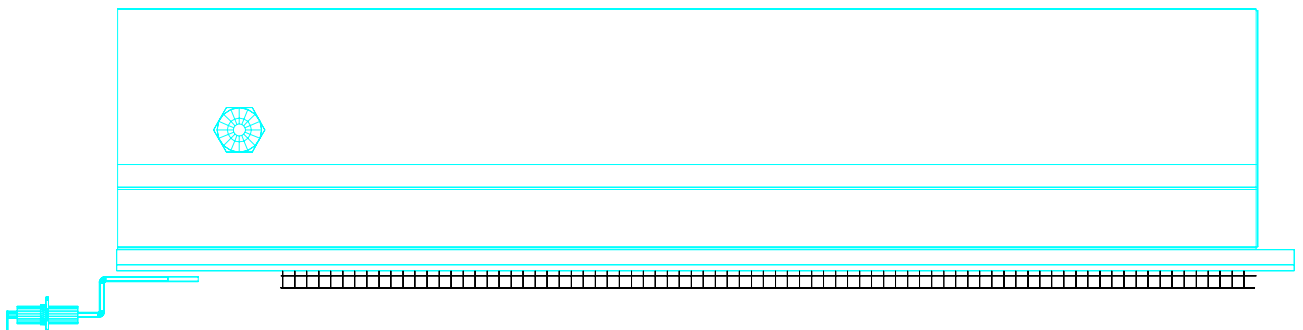

Ignition Electrode Position

1.10 Checking the Connected Gas Pressure (Nominal Pressure)

Close the gas cock where the gas line is connected to the machine and attach a manometer to the tap (allen screw) on the gas cock. With the manometer connected, open the gas cock and ignite all burners. **Along with all other gas appliances at the location in operation, measure the gas pressure.**

This ideal operating pressure should be 5.5" W.C. for natural gas and 11" W.C. for LPG.

If the pressure is too high and can not be adjusted downward, check to see if the proper adjusting spring is in the regulator. If this is correct, the regulator membrane may have been ruptured by excessive gas pressure and may have to be replaced. Do not operate the rotisserie if the gas pressure exceeds the ideal values.

If the operating pressure is below 5.5 " W.C. for natural gas or below 11 " W.C. for LPG, the unit should not be operated. The pressure should be adjusted to the ideal setting using the pressure regulating screw on the pressure regulator.

If the pressure is too low and can not be adjusted upward, also check the regulator. If this is operating properly, verify the pressure coming out of the main gas meter. Another typical source of this pressure problem is that the gas line (pipe) diameter leading up to the unit is too small. If the gas line is under-sized, the appropriate pressure may not be reached. Do not operate the unit if the pressure falls below the ideal values.

If the measured pressure is still below the ideal range and it is not possible to resolve the problem, the local gas company or gas supplier should be contacted so that they can resolve the problem.

After the pressure has been set, close the gas cock once again, remove the manometer, seal the gas tap, and then re-open the gas cock.

WARNING: After an installation, repairs, or maintenance, make sure that there are no gas leaks anywhere in the gas lines or system.

1.11 Maintenance, Response to Technical Problems.

Should a technical problem arise for any reason, shut off the machine and call for technical service.

A routine maintenance should be carried out at least once a year. Contact your local, certified service company for maintenance.

1.11.1 Reasons for problems and solutions

Hickory Industries, Inc.

Problem	Cause	Solution
All electrodes do not spark.	<p>a. Burners not "on".</p> <p>b. Electrical system not grounded properly.</p>	<p>a. Make sure that the TEMPERATURE switch, the individual burner switches are on. Thermostat must be set (i.e. 550°F) and timer must be operational (cook cycle).</p> <p>b. Make sure that the three pronged plug supplied with the unit is being used, that the polarity is correct, and the rotisserie is properly grounded.</p>
One electrode does not spark.	<p>a. Electrode tips too far apart.</p> <p>b. Electrode tips are dirty or carbonized.</p> <p>c. Electrode not grounded.</p> <p>d. Ignition wire loose.</p> <p>e. Ignition wire not properly insulated.</p> <p>f. Ignition module faulty.</p>	<p>a. Adjust electrode tips to 1/8" apart.</p> <p>b. If the machine is used, fat may have carbonized on the electrode tips or rust may have appeared. This prevents proper sparking. Sand and clean metal rods.</p> <p>c. Make sure that electrode is properly fastened and makes solid contact with the rotisserie body.</p> <p>d. Make sure that the ignition wire is properly fastened to the ignition module and to the electrode.</p> <p>e. Check the ignition wire for breaches which may cause sparking to occur between the cable and the body of rotisserie. Repair cable at breach.</p> <p>f. Check electrical input to module. Module may need to be replaced.</p>
All electrodes spark, no burner lights.	<p>a. Check all gas flow.</p> <p>b. Check polarity on the electrical connections.</p> <p>c. Flame is too weak. Not enough gas flow.</p>	<p>a. Turn all manual gas valves to "on". Make sure all solenoid valves open.</p> <p>b. Make sure that the hot, neutral, and ground leads are properly matched up. If neutral and hot are switched, the "flame on" signal will not reach ignition module, locking out gas.</p> <p>c. Check the operating gas pressure.</p>
An electrode sparks, flame does not light.	<p>a. Electrode tips are too far from burner.</p>	<p>a. Adjust the tips of the electrode rods so that they are about 1/8" from the burner surface. Make sure no contact occurs between the rods and burner.</p>
Burner ignites for 5 to 10 second and then goes off, especially in the morning when cold	<p>a. High humidity environment, such as caused by leaving water in drip pan overnight.</p> <p>b. Unit not properly adjusted to new conditions.</p>	<p>a. Switch exhaust hood to on before igniting the unit. Also open one of the sliding glass doors.</p> <p>b. Re-adjust ignition prongs.</p>

1.12 Spit Drive Mechanism

This unit is equipped with a planetary motion spit drive system. This means that each spit is turning upon its axis at the same time that they turn about the center shaft. When the motor switch is turned to on, the disks and the spits will begin to turn. Insure that the mechanism turns smoothly when testing the unit.

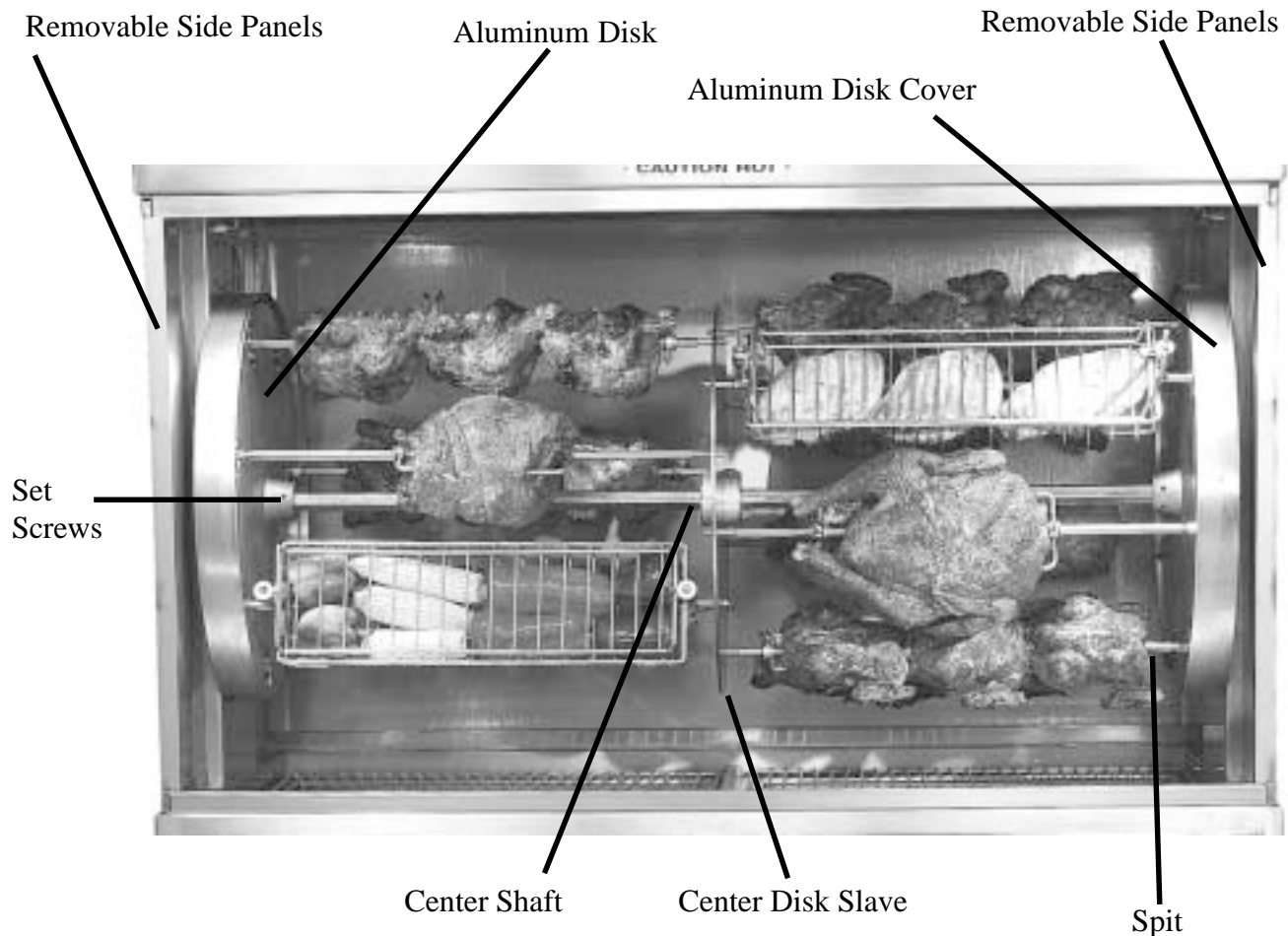

Before cooking, it is imperative that the center shaft and the set screws be covered and protected with aluminum foil. This will prevent fats from carbonizing on the shaft, making the removal of the aluminum disks much easier in the future. If the screws and shaft are not protected, eventually it may be impossible remove them should there be a problem in the spit drive mechanism.

The driven and the stationary drive gears are located behind the aluminum disks. These can be viewed by taking out the removable side panels (there are four removable panels). The driven gears and the stationary gear should be viewed once a week to check for fat or carbonization build-up. Any fat or dirt should be cleaned off since a build-up will eventually damage the drive system.

In order to access the entire drive system, loosen the set screws fastening the aluminum disks to the center shaft. Once loose, the disks can be slid along the center shaft toward the steel slave disk in the center.

NOTE: If fat or carbon have built up on the set screws or on the center shaft, it may not be possible to move the aluminum disks!

With the disks away from the sides, all components of the drive mechanism should be thoroughly cleaned. This will guarantee that the drive mechanism works smoothly.

Even though the aluminum disks are protected with stainless steel covers, fat will eventually build up on the gears. If this fat is not cleaned, it will eventually carbonize. When the carbon build-up is serious enough, the drive mechanism will jam and it will need to be replaced.

When replacing the disks, a slight dab of FDA (food safe) approved gease should be added to all gears.

Finally, when inserting spits, make sure to stop the motor! This unit is supplied with a foot switch which will stop the drive mechanism, allowing the operator to insert the spits easily! If spits are inserted without stopping the motor, there is a chance that the drive system will be jammed and cause severe damage.

1.13 Testing or Checking for Safety

After a conversion, a new installation, or after a repair, it is important that the unit be tested to insure that it operates properly. This should include the following:

Test the gas system for gas leaks.

Check that the unit has enough clearance behind and to the sides.

Check that enough primary and secondary air is available (strong blue flame on the pipe burner, bright orange gas generators).

Check for potentially flammable objects or potential flammability problems.

Check for proper ventilation and exhaust.

Check for proper room ventilation.

1.14 Description of the Electrical Connection

The electrical connections are to be made in accordance to local and national codes.

All gas machines operate with 120 Volt, single phase, 60 Hz. A NEMA 5-15P plug is supplied with the units.

All pertinent electrical information can be taken from the electrical diagram.

NOTE: Proper polarity in the electrical system is needed for proper operation of the gas system!

1.15 Electrical Diagram

Hickory Industries, Inc.

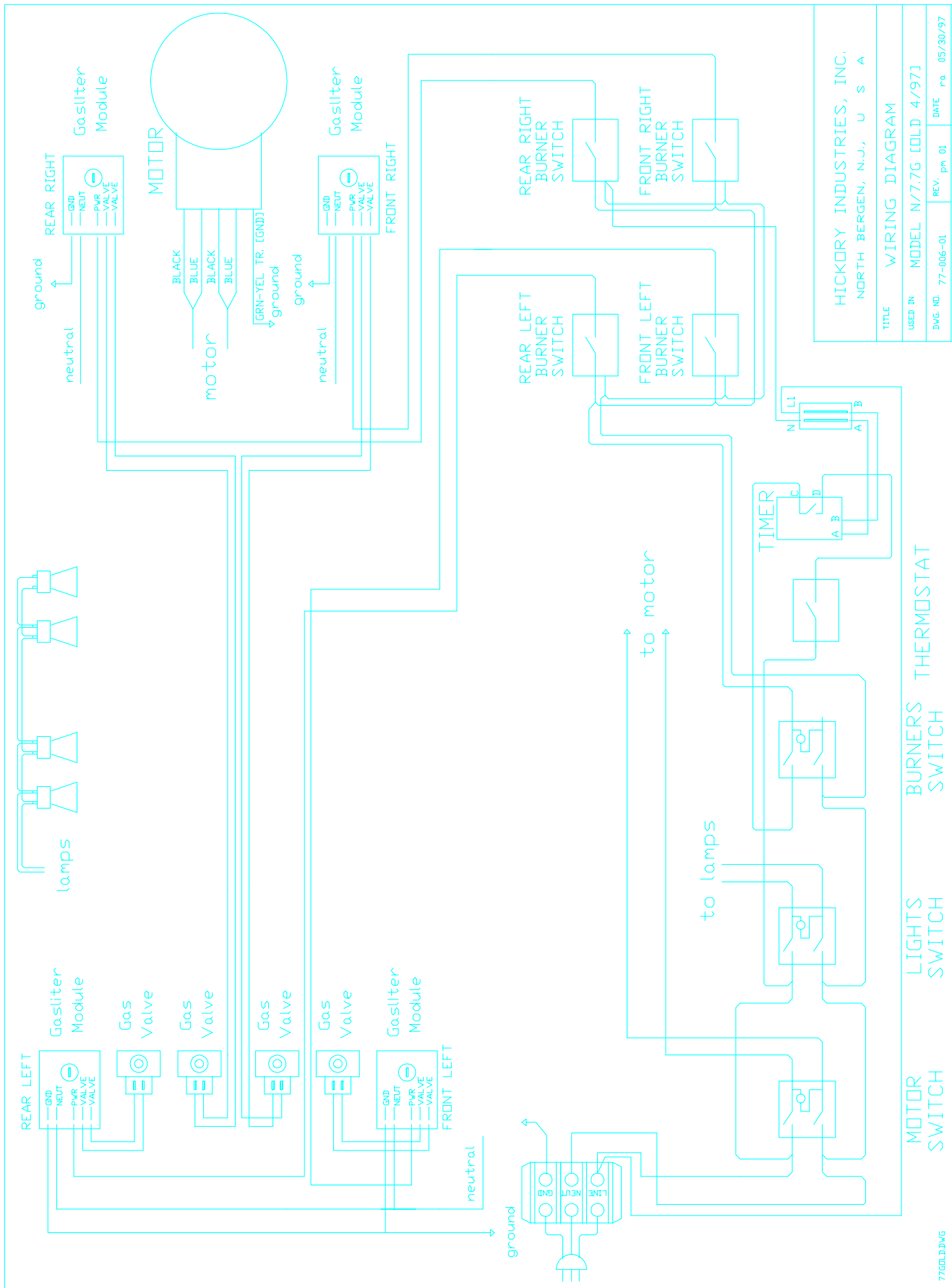

HICKORY INDUSTRIES, INC. NORTH BERGEN, N.J., U S A			
TITLE	WIRING DIAGRAM		
USED IN	MODEL	N/7.7G	OLD 4/97
DWG. NO.	77-006-01	REV.	PH 01
		DATE	05/30/97

7760LD.DWG

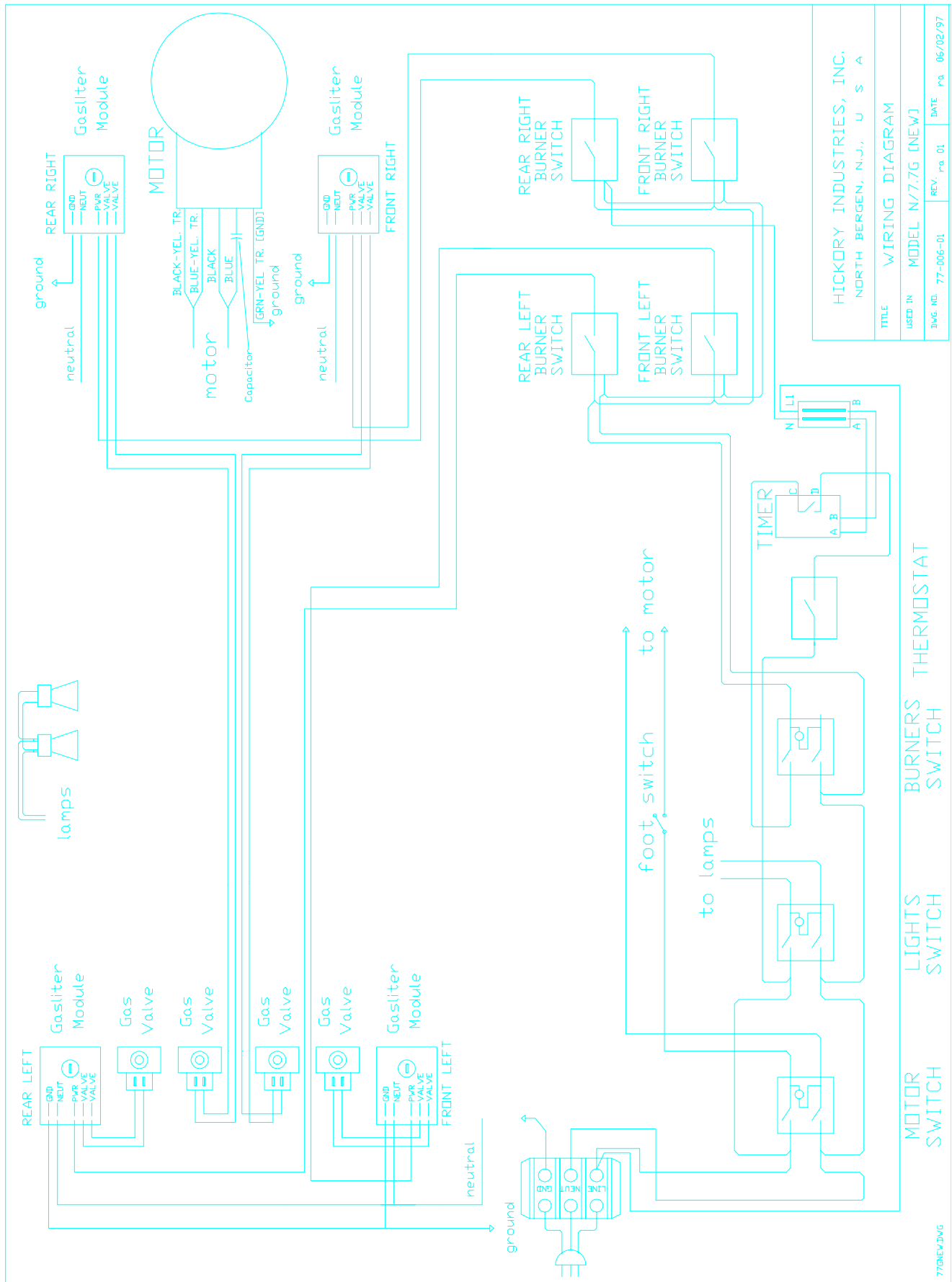

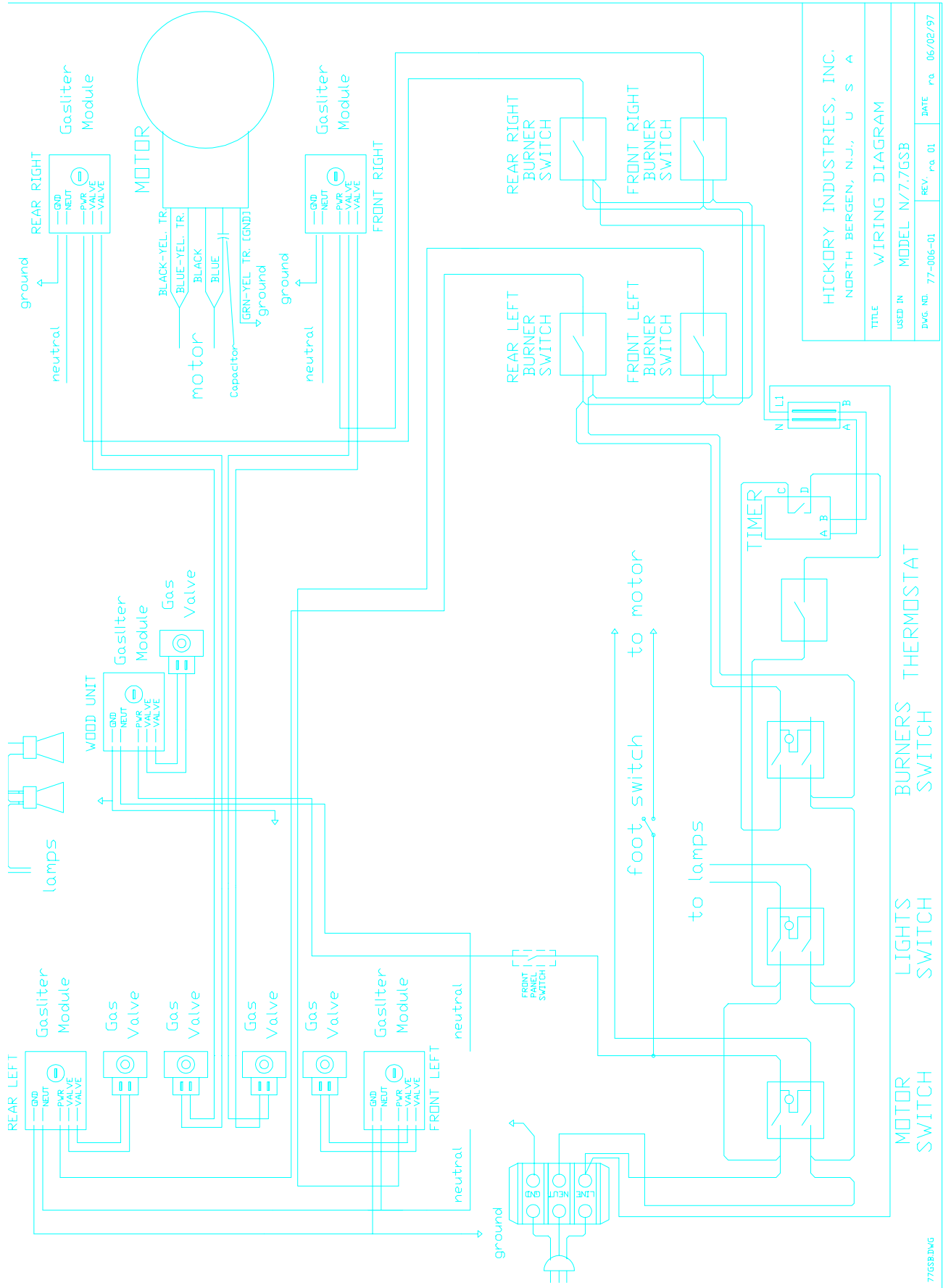

HICKORY INDUSTRIES, INC. NORTH BERGEN, N.J., U S A	
TITLE	WIRING DIAGRAM
USED IN	MODEL N/7.GSB
DWG. NO.	77-006-01
REV.	REV. No. 01
DATE	06/02/97

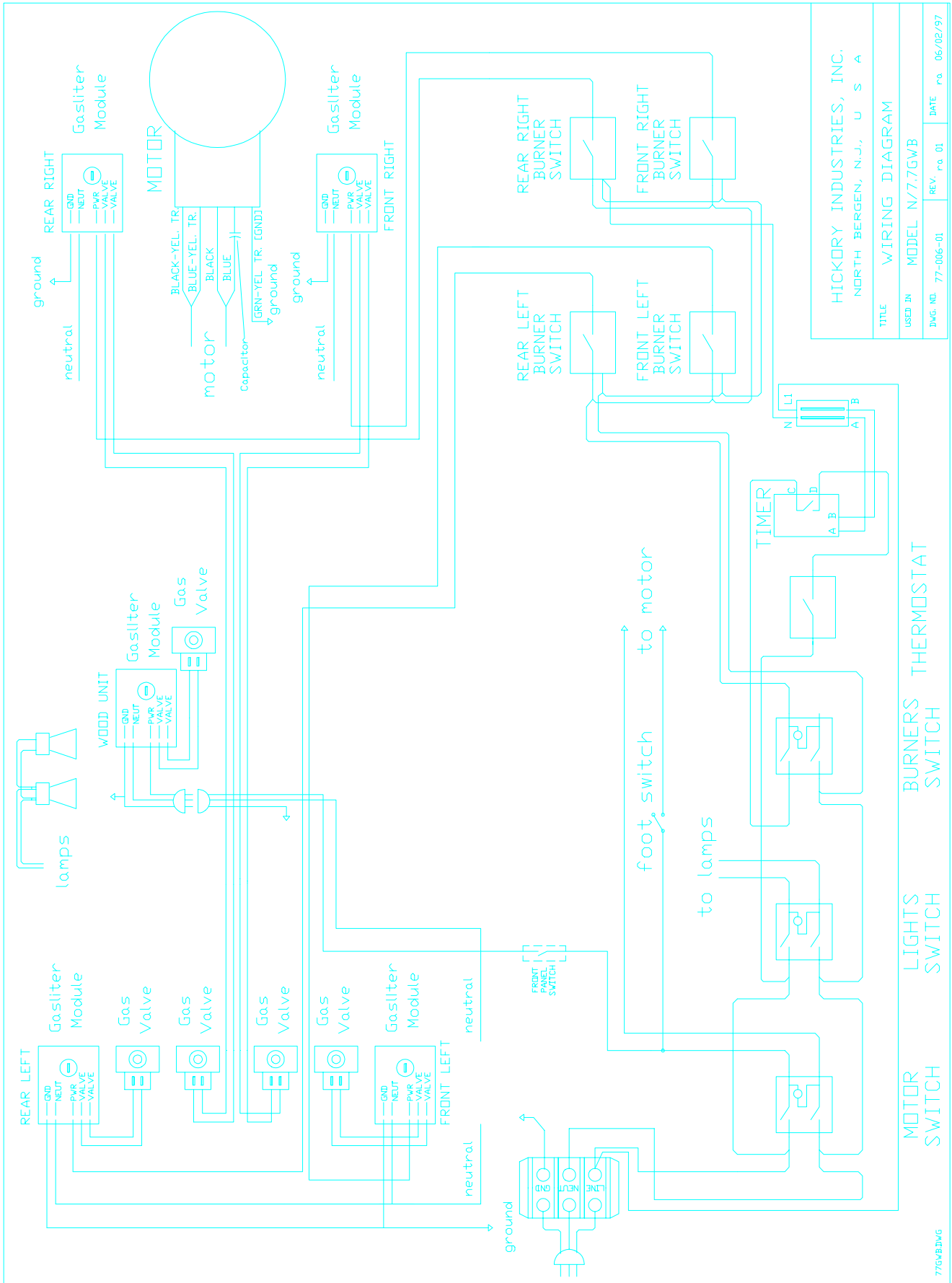

1.16 Parts List for N/7.7 G

Item	Qty.	Description	Material	Length	Size	Manufacturer
	1	Center Shaft	Steel			Hickory
719	1	Drive Bearing (Left - complete with teflon liner)				Hickory
720	1	Drive Bearing (Right - complete with teflon liner)				Hickory
766	2	Brass Shaft Lining - (in use with older models)				Hickory
701	2	Aluminum Disk Drive (Bare)	Cast Aluminum			Hickory
703	2	Alum. Disk Drv. (Complete w/ Spit Driven Gears)				Hickory
	4	Allen Screws (Aluminum Disks)	Steel	1"	1/8"	Hickory
714	1	Disk Retaining/Shearing Pin (used with older units)	Steel			Hickory
761	14	Spit Driven Gear Assembly	Steel (Chromed)			Hickory
755	14	Snap Ring (Spit Driven Gears)	Steel			Hickory
759	14	Spit Driven Gear Bearing	Steel (Chromed)			Hickory
760	14	Spit Driven Gear	Steel (Chromed)			Hickory
764	14	Teflon Bushing - 1/4" round				Hickory
765	14	Teflon Spit Drive Bearing				Hickory
762	2	Stationary Gear	Steel			Hickory
702	1	Center Disk Slave	SS			Hickory
	2	Allen Screws (Center Disk - 1/2 threaded)	Steel	1"	1/8"	Hickory
710	1	Chain (Roller - 7.7)	Steel			Hickory
711	1	Chain Link (Roller - 7.7)	Steel			Hickory
721	1	Drive Sprocket - Roller Chain	Steel			Hickory
	1	Allen Screw (Drive Sprocket)	Steel	3/8"	1/8"	Hickory
	1	Shearing Pin (Drive Sprocket)	Steel			Hickory
722	1	Driven Sprocket - Roller Chain	Steel			Hickory
	2	Allen Screw (Driven Sprocket)	Steel	1"	1/8"	Hickory
	1	Shearing Pin (Driven Sprocket - older units)	Steel			Hickory
	1	Keyway (Driven Sprocket - newer units)	Steel			Hickory
736	4	Ignitor Electronic Ignition				Channel
	4	Ignition Wire				
737	4	Ignitor Module (Gaslite)				Channel
741	7	Micro Switch & Toggle				Marquardt
768	1	Thermostat Knob				
769	1	Timer				Eaton
742	1	Motor, 1/2 HP - 120V				Bodine
150	2	Lamp Par, 240 V (older units use 4)				Hickory
152	2	Lamp Socket (older units use 4)	Ceramic			Hickory
	1	Foot Switch (to stop motor)				
	2	Drip Pan	SS			Hickory
121	2	Drip Pan Plug	Brass			Hickory
122	2	Drip Pan Receptacle	Brass			Hickory

1.16 Parts List for N/7.7 G (Contd.)

Item	Qty.	Description	Material	Length	Size	Manufacturer
	1	Pressure Regulator (Connection) RV53	Alum.		1"	Maxitrol
	1	Nipple	Steel	1.5"	1"	Hickory
	1	Gas Cock Valve	Steel		1"	Jomar
	1	Nipple	Steel	3"	1"	Hickory
	2	Elbow (90°)	Steel		1"	Hickory
	1	Pipe	Steel	6"	1"	Hickory
	1	Pipe	Steel	13.5"	1"	Hickory
	1	T-Connector (Reduction)	Steel		1" to 3/4"	Hickory
	2	Nipple	Steel	2"	3/4"	Hickory
	2	T-Connector (Reduction)	Steel		3/4" to 1/2"	Hickory
	2	Nipple	Steel	1"	1/2"	Hickory
729	4	Basotrol H91EA-5 Solenoid Gas Valve			1/2"	Basotrol
	6	Elbow (90°) St. - Male to Female	Steel		1/2"	Hickory
	2	Flexible Pipe Connector (M-M-F)	SS		1/2"	Dormont
	10	Flexible Pipe Connector (M-F)	SS		1/2"	Dormont
	6	Flexible Pipe Connector (M-M-F)	SS		1/2"	Dormont
	8	Flexible Pipe	SS	12"	1/2"	Dormont
	4	Pipe	Steel	51"	1/2"	Hickory
	2	Elbow (90°) - Female to Female	Steel		1/2"	Hickory
	2	Pipe	Steel	46"	1/2"	Hickory
	2	Nipple	Steel	1"	1/2"	Hickory
730	4	Gas Burner	Incoloy			Hickory
743	4	Orifice (Blank)	Brass			Hickory
	1	Glass Track, Top	SS			Hickory
	1	Glass Track, Bottom	SS			Hickory
145	2	Glass Trolley, Regular	Alum.			Hickory
733	2	Glass Tempered			27.5" x 29.25"	Hickory
110	2	Caster w/ brake	Nylon			Hickory
111	2	Caster w/o brake	Nylon			Hickory
756	14	Spit Complete	SS			Hickory
185	5/Spit	Skewer Double	SS			Hickory
186	2/Spit	Skewer Single	SS			Hickory
219	1/Sk.	Thumb Screw	Steel			Hickory
123	1	Electrical Grounding Cap				Hickory
		Electrical Wire				Janor Wire
	1	Connection Cable				TIP Products
104	1	Contact Section 242 (terminal)				Buchanan
105	1	Contact Section 250 (end-piece)				Buchanan

*All components are inventories and sold through Hickory Industries and their distributors and dealers.

1.17 List of Additional Parts for N/7.7G with Show Burner (SB)

737	1	Ignitor Module (Gaslite)			Channel
729	1	Basotrol H91EA-5 Solenoid Gas Valve		1/2"	Basotrol
	1	Pipe Burner	Steel		Hickory
	1	Burner Rack	SS		Hickory
	1	Toggle Switch for Pipe Burner			
736	1	Ignitor Electronic Ignition			Channel
	1	Ignition Wire			
	1	Ignitor Shield			

1.18 List of Additional Parts for N/7.7G with Woodburning Module (WB)

737	1	Ignitor Module (Gaslite)			Channel
	1	Toggle Switch for Pipe Burner			
	1	Ignition Wire			
	1	Connection Cable			

1.19 Parts List for Woodburning Module (WB)

Item	Qty.	Description	Material	Length	Size	Manufacturer
	2	Ash Pan	SS			Hickory
	2	Wood Loading Door	SS			Hickory
	2	Handle - Side Loading Door	Metal			Hickory
	2	Wood Burning Racks	SS			Hickory
	1	Brick Panel	Metal/Brick			Hickory
227	1	Venturi Cap	Iron			Hickory
229	1	Venturi Lock Nut 3/8" ID, 3/4" OD	Iron			Hickory
231	1	Venturi Nipple	Steel			Hickory
233	1	Venturi Threading Tube, Brass	Steel			Hickory
234	1	Venturi Tube	Iron			Hickory
232	1	Main Orifice, Nat. Gas	Brass			Hickory
	1	Gas Pipe Burner	Steel		1 - 1/2"	Hickory
729	1	Basotrol H91EA-5 Solenoid Gas Valve			1/2"	Basotrol
	1	Gas Cock Valve	Steel			Hickory
736	1	Ignitor Electronic Ignition				Channel
	1	Ignitor Shield				
110	2	Caster w/ brake	Nylon			Hickory
111	2	Caster w/o brake	Nylon			Hickory
123	1	Electrical Grounding Cap			Hickory	
		Electrical Wire			Janor Wire	
	1	Connection Cable			TIP Products	

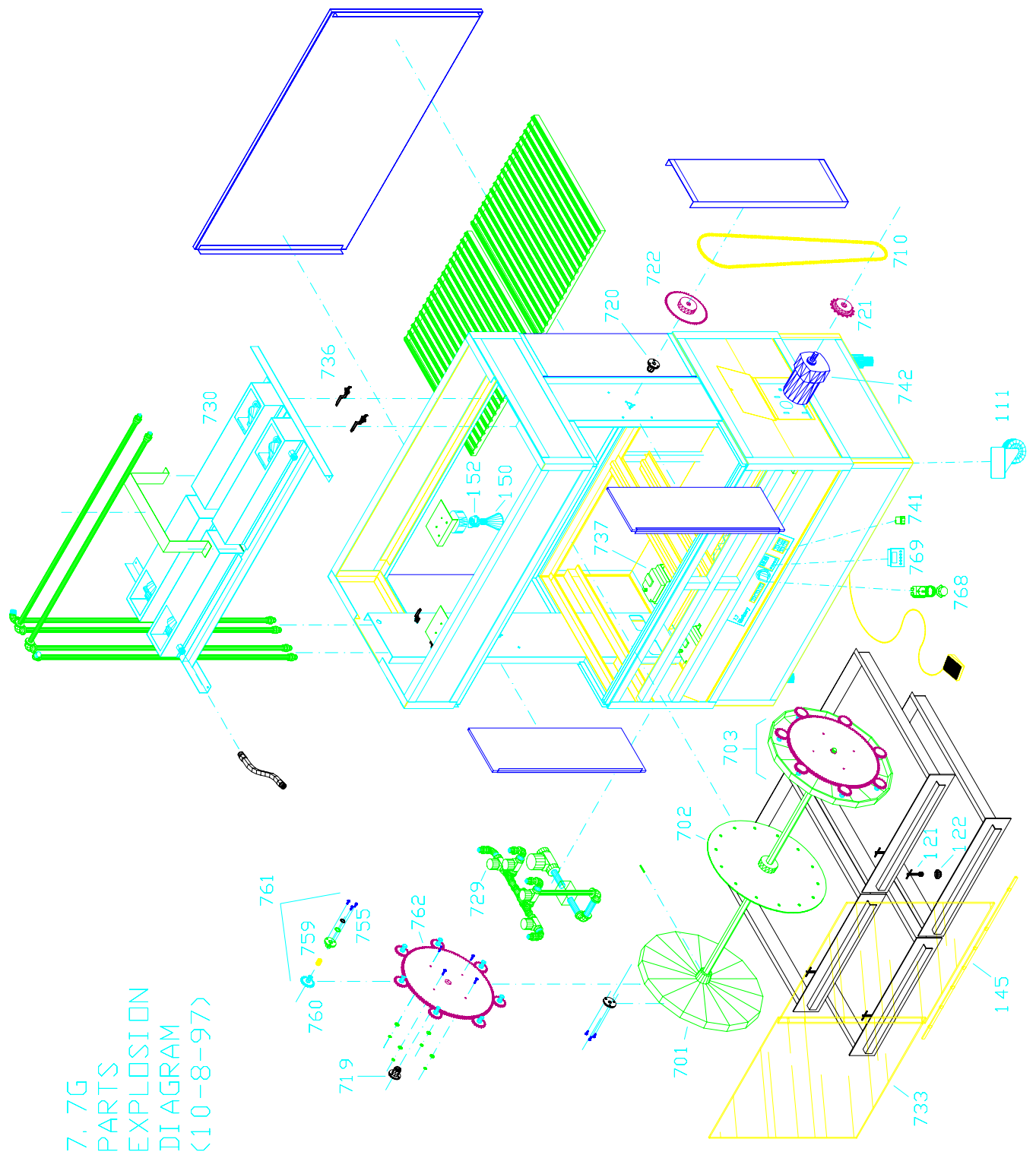

7.7G
PARTS
EXPLOSION
DIAGRAM
(10-8-97)

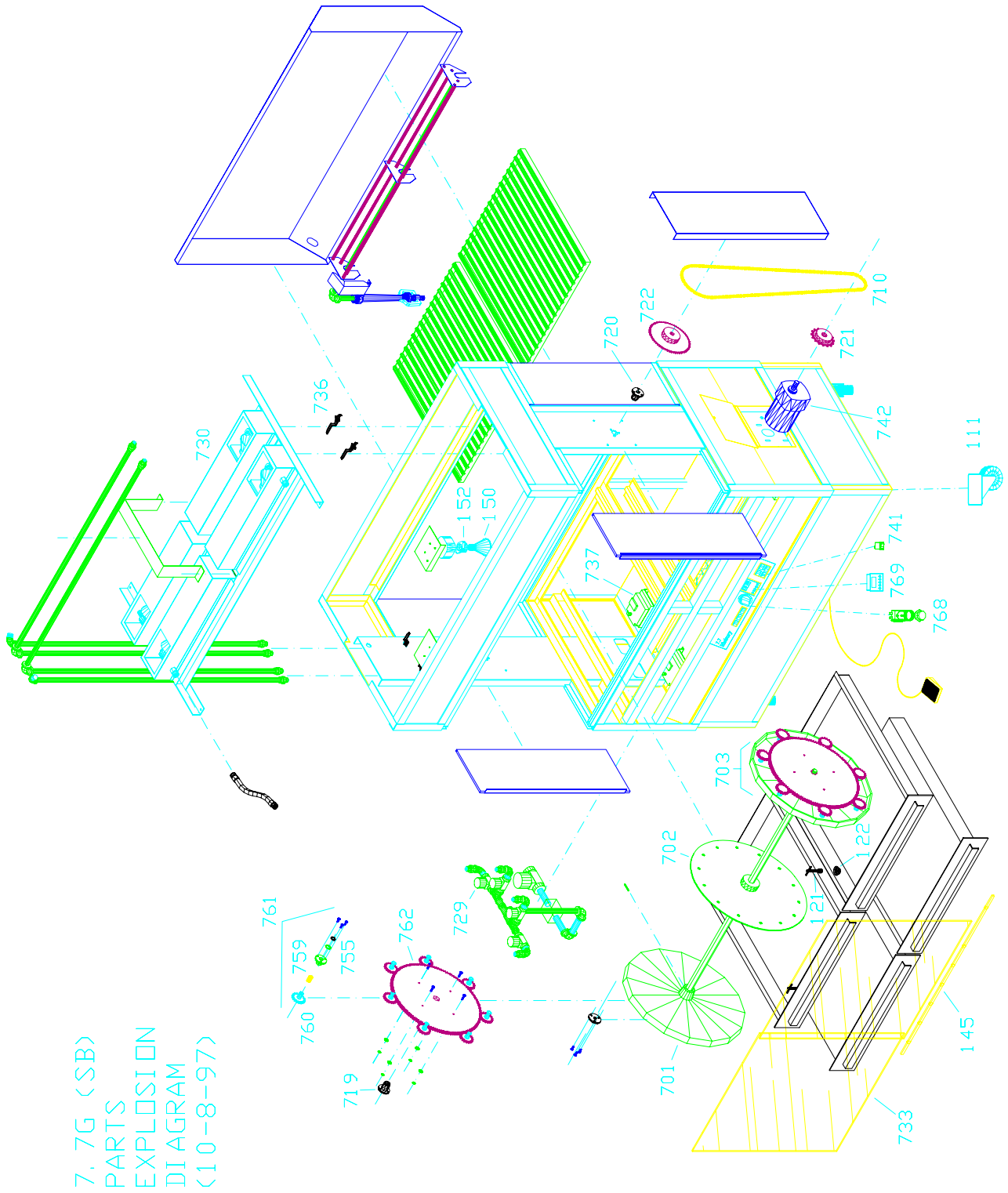

7.7G (SB)
PARTS
EXPLOSION
DIAGRAM
(10-8-97)

Addendum

Pass Thorough-units

When the unit comes with a "rear pass through" option, the following must be noted:

Motor switch must be "On" in order to preheat the oven using the show burner.

In order to turn the upper burners, the motor switch must be "On". The motor switch supplies power to the show burner as well as the upper infra-red generators.

When opening the rear doors, both the rear and upper burners will turn off. To unload product from the rear, the rear foot pedal must be depressed to pause the motor. Once the rear doors are closed, the rear and upper burners will restart.

In an emergency, press the Emergency Stop (red mushroom) switch. This will de-energize the unit and consequently, the timers will have to be reprogrammed. To re-energize the unit, press the Emergency Stop switch again.