

# OPERATOR'S MANUAL

# TX & D-TX Series

TXA, TXE, TXM, D-TXA, D-TXE, D-TXM



TXA-SS



D-TXA-2-18SS



TXE-SS



D-TXE-2-18SS



TXM-SS



D-TXM-2-18SS

*For Customer Service:*

*Call 1-800-835-0606 or Visit [hixcorp.com](http://hixcorp.com)*



# CONTENTS

<i>Receiving &amp; Setup</i> .....	3
<i>Power</i> .....	4
<i>Users Adjustable Settings</i> .....	5
<i>Machine Presets</i> .....	6
<i>Pressing Dough</i> .....	7
<i>FAQs</i> .....	9
<i>Leveling Instructions</i> .....	11
<i>Cleaning &amp; Maintenance</i> .....	13
<i>Parts List</i> .....	14
<i>Warranty</i> .....	26

BEFORE warranty repair you MUST get Prior Authorization



Intertek



Intertek

# RECEIVING & SETUP

## PLATEN SURFACE

Slight surface imperfections are a normal part of the casting process for the platens on your press. These are not considered a defect and do not affect the functionality of the machine in any way.

## SHIPPING OR RETURNS

**\*NOTE\*** *Save all of your shipping/ packing material. Do not risk costly shipping damage, ship only in original box.*

1. Fasten machine to plywood shipping base with bolts provided
2. Tie or tape handle securely to base.
3. Place in original box, and put side liner and top liner in place. Fold flaps and seal the box.  
(Additional bottom boards, box, and liners may be obtained from your supplier for a nominal cost.)

## UNPACKING

Remember to save all packing material - including box, liner, and board. You may need these for shipping your machine

## INSPECTION

Inspect your machine for hidden shipping damage. Contact the delivery company immediately, should you find damage.

## INSTALLATION

**Mounting Kit Hardware Included:** (Located on the back of unit)

- (4) BOLT 3/8-16x1.000
- (4) WASHER LOCK HEL SPR 3/8 ZPS
- (4) WASHER FLT .406 x 1.500 x .120 ZPS
- (4) FOOT RUBBER1-1/2"OD x 1/4"

1. Lift the press from skid and place on countertop. If you purchased a cart with your press, align legs with holes on top of the cart and bolts (supplied) fasten to cart. You will need a 9/16 wrench.

**CAUTION:** Heavy lifting can cause injury. We recommend two person lifting or use of a mechanical aid when handling this press. Remember to always maintain natural curves of back and bend knees to lift.

2. Plug the cord of the press into a correctly grounded electrical outlet. The correct voltage is indicated on the identification tag of the press.

**NOTE:** Upon receiving your new equipment, some debris or residue may be present on the aluminum platen(s). Clean the platens per the instructions provided prior to first use.

3. Remove wrap from handles and platens.

**WARNING:** Do not use an extension cord to supply power to your press.

4. **(Air models only)** - Supply a clean (void of oils) and dry (void of water) air source of 110-130 P.S.I. (7-8 bar) to the 1/4" NPT air inlet located on the back panel of the machine. Requires 1 CFM (30 L/min). It is strongly recommended that an external air filter and water trap be installed at the machine's air inlet connection. This equipment has small valves and ports that can be blocked from moisture and residue in compressed air causing it to malfunction. Damages to the equipments internal air operated components resulting in unfiltered air not covered under warranty. Combination air/water traps are available at any major hardware store or may be purchased directly from doughXpress® (part #71145).

# POWER

## TURNING THE POWER “ON”

1. Once the machine is plugged into power, the display will show a “Red Icon” as shown below. To turn the power on to the machine, simply press the Red Icon.



2. The display will then come on and look similar to what is shown below.

To turn the Power “OFF” to the machine, simply press the Green “Power” Icon in the upper right corner of the display and the machine will turn “OFF.”



To adjust the temperature or time settings, simply press the “UP” or “DOWN” arrows to change the values.

As the temperature is warming up from a cold start, the temperature digits will be RED when the heat platen temperature is more than 10 degrees away from desired set point temperature.

When the platen temperature is less than 10 degrees, but more than 5 degrees from the desired set point the temperature displayed will be YELLOW.

When the platen temperature displayed is within 5 degrees of the desired set point, the temperature digits will be GREEN.

When the actual platen temperature reaches the set point, the controller will BEEP.

3. A little “Red Dot” shown above in the lower left corner of the temperature display window represents the “Heat Light.” This indicator will be on when the controller is applying power to the heating element. It is normal for this indicator to flash on and off as heat is required.

# USER ADJUSTABLE SETTINGS

## USER ADJUSTABLE SETTINGS

Pressing the “GEAR” Icon  in the upper left corner of the Home Screen will switch the screen to the user settings menu, shown below.

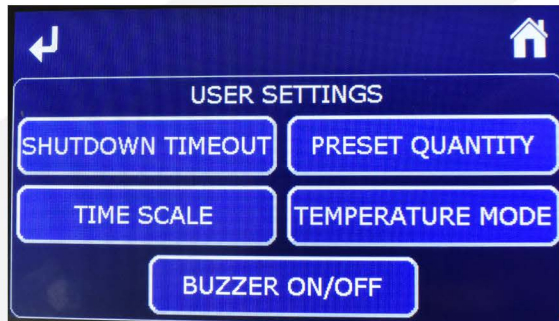

Pressing the “Back Arrow” Icon in the upper left corner of the display will take you to the previous screen.

Pressing the “Home” Icon in the upper right corner of the display will take you to the “HOME” Screen.

Pressing any of the USER SETTINGS buttons will take you to one of the screens shown below where you can adjust the machine settings to your preferences.

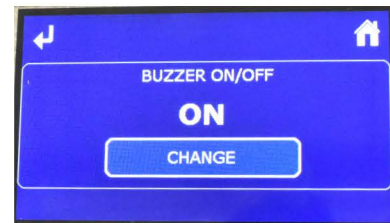
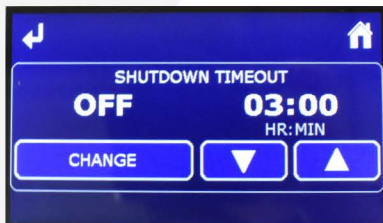

Once you have made the desired adjustments, press the “Back Arrow” or “Home” Icon.

Any changes in any of the settings or values you have made will be automatically stored as you leave that screen.

# MACHINE PRESETS

## PRESETS FOR TIME & TEMPERATURE SETTINGS

The controller has several Time and Temperature Preset options (No Presets, Two Presets, Four Presets, Toggle Two Presets) which are selectable in the “User Adjustable Settings” as outlined on the previous page.



## ON THE HOME SCREEN

If one of the buttons is “GREEN” then that button is the ACTIVE time and temperature preset on the controller. See below:



2 presets option



4 presets option

If you wish to make an adjustment to the time or temperature, simply press the UP/DOWN arrows next to the Time or Temperature values to change the number to the new setting desired.

**NOTE:** You will notice when you change either the Time or the Temperature away from the preset values, all the preset buttons will turn “Gray.”

To store the new Time or Temperature value(s) in a preset button location, simply press and HOLD on the desired preset button for 2 seconds. Once the new values are stored, the button will turn GREEN and the controller will BEEP to acknowledge the new values are stored.

To “recall” a preset, simply touch on the desired preset button and the Time and Temperature setting stored in that location will be recalled and displayed in the Time and Temperature values.

# PRESSING DOUGH

## PRESSING DOUGH

Your dough press is designed for easy use and operation to reliably press dough balls. Thickness, shape, and size are directly related to your dough ball, its shape, the temperature of the dough, the recipe of your dough, the type of lubricating food oil, as well as the settings of your machine. You should experiment with the following for the results you want.

**CAUTION:** Excessive pressure can cause structural damage, voiding the machine warranty!

1. Touch the power button located on the front of the control panel.
2. Set the desired temperature on the time/temperature control panel as instructed in this manual. Generally 110°-130°F for room temperature dough and 140°-150°F when using refrigerated dough. When the actual platen temperature reaches the set point, the controller will BEEP.

**WARNING:** Never attempt to press frozen dough. Personal injury and damage to your machine could result!

**NOTE:** This symbol represents “Hot Surfaces”



3. With the press in the open position, adjust the press to the desired thickness by turning the thickness control knob located at the top of the press. Thickness is reduced by turning the knob clockwise. Thickness is increased by turning it counterclockwise.

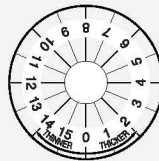

**NOTE:** The numerical thickness setting are for reference only and have no specific value to the thickness of a pressed or finished product.

**NOTE:** Adjustments may be required from one product to another and will vary to achieve the desired result.

**WARNING:** Make all adjustments while press is open. Adjusting the thickness while under pressure will result in damage to the press.

Thickness knob

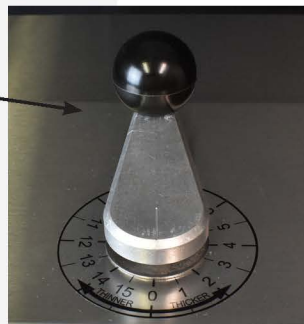

# PRESSING DOUGH

4. Lightly lubricate the lower platen with olive oil, food/cooking oil or other food release lubricant when pressing pizza dough. Place corn tortilla dough balls between sheets of parchment paper.

**TIP:** Dough balls at room temperature give you the best results.

5. Place your dough ball in the center of the lower platen and add a small amount of your food lubricant to the top of the dough ball. **Do not add flour or dust with flour.**
6. Pull down the handle all the way, applying pressure, until it stops.
7. After the designated time has elapsed (generally, 3-10 seconds for room temperature dough) raise the handle all the way up to the open position.

**CAUTION:** Excessive pressure can cause structural damage, voiding the machine warranty!

8. Remove your flattened dough and place on a screen or pan with the top side face down. You are now ready for final shaping, edging, and toppings. Tortillas can be moved to a tortilla warmer or skillet for finishing.
9. Move on/off switch to "OFF" when finished using the press for the day. This will turn the power off to the entire machine.

<b>DOUGH BALL WEIGHTS</b>			
<i>Pizza Crust Size</i>	<i>Weight of the Dough Ball</i>	<i>Tortilla Crust Size</i>	<i>Weight of the Dough Ball</i>
6"	5-8 oz.	6"	1-1.5 oz.
8"	6-10 oz.	8"	1.5-2.5 oz.
10"	8-12 oz.	10"	2.5-3.25 oz.
12"	16-18 oz.	12"	3.25-3.75 oz.
14"	18-20 oz.	14"	4-4.5 oz.
16"	20-22 oz.	16"	4.5-5 oz.
18"	22-24 oz.	---	-----

## **DOUGH SHRINKAGE**

*Ways of Overcoming this Problem:*

1. **Recipe** - What is the percentage of water content in the dough? What is the percentage of oil content in the dough?
2. **Mixing** - Mixing procedure, such as water temperature and mixing speed.
3. **Dough Preparation** - What is the time between mixing and pressing? How is the dough being stored?
4. **Pressing** - What is the temperature of the dough when pressing? What is the temperature of the press when pressing? How long is the dough being pressed?

# FAQs

## PIZZA DOUGH

### **Q: Why won't my dough press to size?**

- Weight of the dough ball - not enough dough
- Temperature of the dough ball might be cold - higher temp/longer press time
- Set to thick - change thickness setting

### **Q: When I press my dough it gets sticky? Why?**

- Very wet dough - turn up temperature
- Platens are not clean - possible flour build up

### **Q: Why won't my dough press out even?**

- Unlevel platens

### **Q: Why is my dough tearing when I press?**

- Usually this is caused by under mixing the dough in the mixer - mix on slow speed for a minimum of 10 minutes
- Cold or frozen particles in the dough

### **Q: What temperature should I be pressing the dough?**

- Cold dough could vary from 130°F to 170°F
- Warm dough or room temperature dough 100°-110°F

### **Q: How long should I be pressing the dough?**

- Warm dough 2-7 seconds
- Cold dough 5-10 seconds

### **Q: Will the heat kill the yeast?**

- No - yeast dies at 180°F for 2-minutes - The temperature we are pressing could range from 100°-170°F for a maximum pressing time of 10 seconds. This will not affect the yeast in the dough.

### **Q: Is 18" the only size crust I can get with this press?**

- No - The weight of the dough ball and your thick & thin setting will determine the size of your crust. Different dough ball weights will determine the size of your crust.

### **Q: How do I get an edge with the press?**

- Press out dough normally - (2) ways you can get an edge...
  - a. After pressing crust, form edge by hand
  - b. When saucing crust leave a 1/4" to 1/2" ring from the edge to let your oven bake the edge naturally for a nice handmade look.

# FAQs

## TORTILLA DOUGH

### **Q: Why won't my dough press to size?**

- Weight of the dough ball - not enough dough
- Set to thick - change thickness setting
- Dirty or unclean platens

### **Q: Why won't my dough press out even?**

- Dough ball placement
- Unlevel platens

### **Q: Why is my dough coming apart when I press it?**

- Pressing too long with too much heat
- Not enough oil on dough ball
- Build up on platens

### **Q: What temperature should I be pressing at?**

- 275° - 325°F

### **Q: How long should I be pressing the dough?**

- 2 -3 seconds

### **Q: Can I press corn tortillas?**

- Yes - but you need to use either parchment or baking paper...
  - a. Place paper down on the platen
  - b. Place dough ball(s) on paper
  - c. Place another sheet of paper on top of dough ball(s)
  - d. Press

### **Q: Can I cook the tortillas on the press?**

- Yes - cooking the tortillas on the press can be done in the following manner
  - a. Set press temperature 275° - 325°
  - b. Press dough ball(s) 2-3 second press
  - c. Lift handle and leave tortillas on lower platen for 1 - 1:30 min.
  - d. Turn tortillas over and leave on lower platen for 1 - 1:30 min. on second side.
  - e. Remove

**NOTE:** For faster production and a better finished product, it is recommend to use a two step process using a tortilla press and tortilla warmer.

# LEVELING INSTRUCTIONS

## TOOLS REQUIRED

- 5/16" Hex Wrench
- 3/8" Socket Drive Ratchet
- 5/8" Socket, Flat Blade Screwdriver

1. Remove the existing four hole plugs using a flat blade screw driver. Be careful not to scratch the surface of the platen mount during plug removal. The caps will be reinstalled after the leveling adjustment is complete.



2. Lower the Top Platen until one side touches to determine which side will be adjusted. In the picture below, the front of the platen could be raised or the back could be lowered.



# LEVELING INSTRUCTIONS

3. On the chosen adjustment side (which is the front in this example), loosen the front hex set screws using a 5/16" hex wrench. Note: When adjusting always loosen at least 2 hex screws adjacent to each other.



4. Adjust the front height of the upper platen up by turning the adjustment nut counter clockwise. Turning the adjustment nut clockwise will lower the front of the platen. Adjust in 180 degree increments, alternating between the two nuts being adjusted.
5. After each adjustment, tighten the hex set screws and then lower the top platen and recheck to see if both are level. In the picture below, the platens are level. Tighten all set screws and test with dough to insure platens are level.



# CLEANING & MAINTENANCE

**WARNING:** Before cleaning, performing maintenance or repairs make sure the machine is turned off and the machine is unplugged.

**\*\*\*This appliance is not waterproof. Never spray or pour water or any other cleaning solution onto this appliance.\*\*\***

## CLEANING ALUMINUM UNCOATED HEAT PLATEN(S)

1. Unplug the machine and allow it to cool.
2. Open the heat platen for easier access.
3. Dampen a nonmetallic scrubbing sponge with a mild soap or detergent to remove any excess material from the heat platen(s).
4. Wipe clean with a dry cloth.

## CLEANING PTFE (XYLON) COATED PLATEN(S) (OPTIONAL FEATURE)

1. Unplug the machine and allow it to cool.
2. Open the heat platen for easier access.
3. Clean the PTFE coated platen with a mild soap and warm water applied with a soft cloth or sponge. Do not use steel wool, scrub sponges, kitchen or oven cleaners or any other kind of abrasive material. This will damage the coating.
4. Wipe clean and dry with a cloth.

## CLEANING OUTSIDE SURFACES OF THE MACHINE

Use a mild soap and warm water applied with a soft cloth or sponge. Do not use steel wool, scrub sponges, kitchen or oven cleaners or other abrasives that will damage the painted surface.

***\*TX & D-TX Series dough presses are available in White or Stainless Steel housings.\****

## LUBRICATION

Your press requires lubrication every 15,000 cycles or every 6 months. Use NSF/NLGI2 rated food grade grease (such as Bel-Rey No-Tox #2 or equivalent). Lubricate all moving or hinged points.

## CIRCUIT BREAKER RESETTING

Should the circuit breaker trip, simply allow the machine to cool for 2 minutes and then reset the circuit breaker by pressing the button back in to allow the machine to come back on. If the circuit breaker continues to trip, have an electrician diagnose the cause of the fault.



# REPLACEMENT PARTS LIST (TXA MODEL)

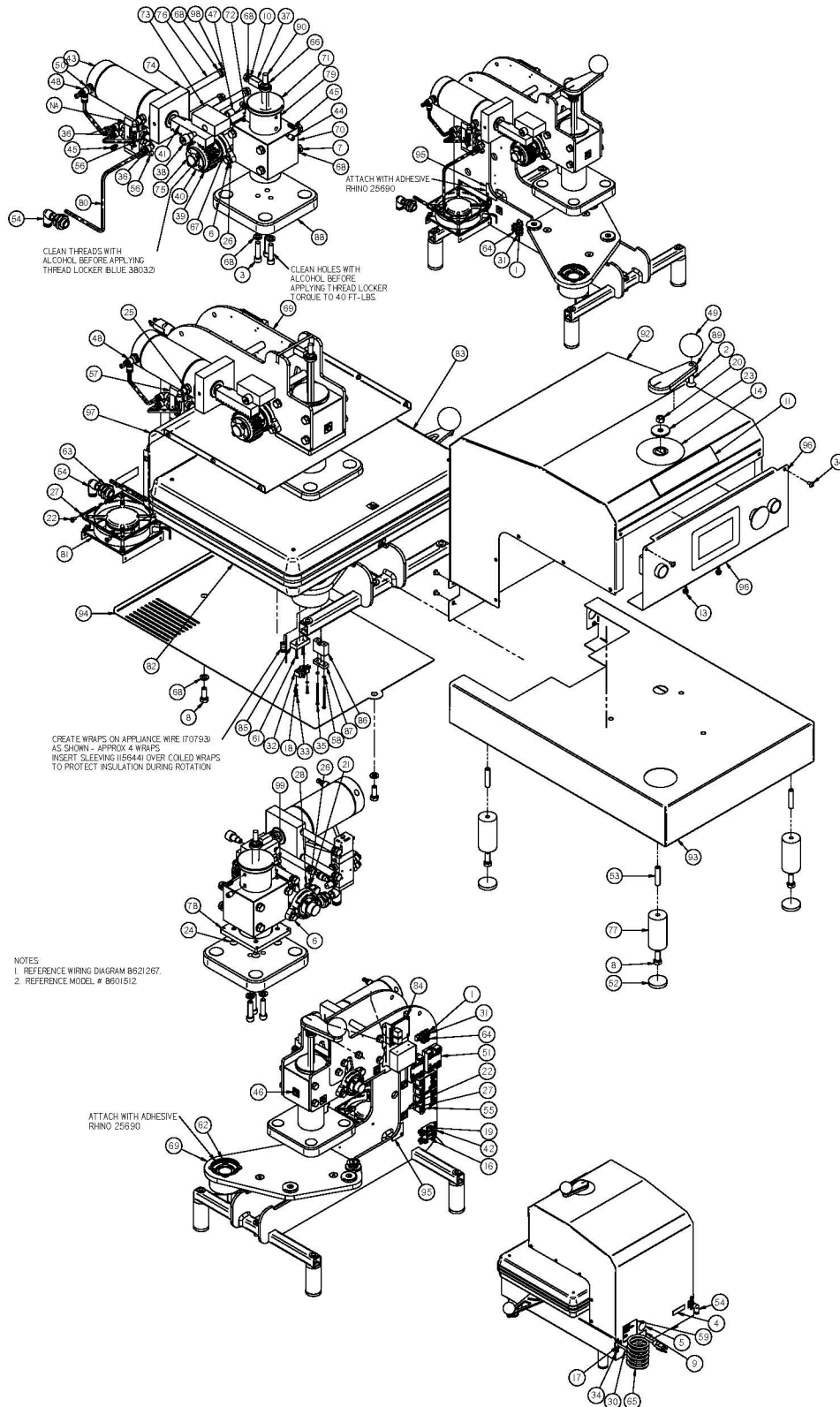

# REPLACEMENT PARTS LIST (TXA MODEL)

ITEM#	PART#	TITLE	ITEM#	PART#	TITLE
1	10021	WASHER LOCK HEL SPR #8 ZP	55	66729	SCREW MCH 10-32x0.375 GRND
2	10027	SCREW FHSKT 3/8-16X1.000 SS	56	67776	FTG MUFFLER 1/4NPT SINT BRZ
3	10341	SCREW CPSKT 3/8-16X1.500 GD 8	57	68101	VALVE SOLENOID 5/2 220V 1/4NPT
4	10454	DECAL CLEAN AIR	58	68330	WASHER LOCK #6 SPLIT ZPS
5	10664	DECAL MADE IN USA	59	70268	DECAL HIX I.D. 3" X 3" SILVER
6	10777	BOLT 5/16-18x1-1/4	60*	70793	WIRE APPL 16GA 250C/600V NPC
7	10843	BOLT 3/8-16X0.750	61	70899	SCREW MCH 6-32X0.750 FHPH
8	10850	BOLT 3/8-16 X 1.000	62	71041	SEAL SHAFT 2.500
9	10963	DECAL, QR CODE DXP	63	71161	FTG BULKHD 1/4NPT BRS
10	11072	BOLT 3/8-24x1.000	64	72223	TERM BD 601-2-KT37, 38,39
11	11327	DECAL, DOUGHXPRESS DOMED 6.75 X 1.5	65	72495	CORDSET 220V 14/3 SJTOW 6-20P
12*	11344	WIRE CUT LIST TXA 16X20 220V 4.3"	66	73247	NUT 3/8-16 JAM NYLON INSERT ZPS
13	11404	SCREW MCH 10-32X0.375 SS	67	76141	BEARING 1" 2 BOLT FLANGE
14	11430	DECAL, THICK THIN DXA 4.3"	68	79418	WASHER LOCK HEL SPR 3/8 ZP
15*	11544	CABLE TIE CT4S-M 3-3/4	69	8600221	ASSEMBLY FRAME WITH SUPPORTS LV
16	13045	FUSE MDA-15 / 65 TS	70	8601034	DP JACK HOUSING
17	13250	CORD GRIP HEYCO 1557 RDD201	71	8601036	DP STOP JACK ADJUSTABLE
18	13919	WASHER LOCK HEL SPR #4 ZP	72	8601037	DP JACK RACK
19	14524	SCREW MCH 4-40X0.250 PHPH	73	8601039	DP CAM ROLLER MOUNT BLOCK
20	14571	NUT 3/8-16 ZPS	74	8601042	DP MOUNT CYLINDER / SET SCREW
21	14605	NUT 5/16-18 ZPS	75	8601043	DP PINION SHAFT
22	15321	SCREW MCH 10-32x0.375 PHPH	76	8601067	DP SPACER FRAME PINION
23	25720	WASHER FLT .406X1.500X.120 ZPS	77	8601083	M-DP LEG 3"
24	28142	SCREW FHSKT 5/16-18x1.000	78	8601085	SPACER HOUSING FRAME COVER DXA
25	28630	FTG 1T EL MALE 1/4Tx3/8NPT	79	8601409	JACK SHAFT DXA LV
26	30910	WASHER LOCK HEL SPR 5/16 ZP	80	8601952	TUBE 0.250ODx0.167ID 9.75
27	32228	WASHER LOCK HEL SPR #10 ZP	81	8605907	P-DP TXMSS FAN ASSY 220v
28	32680	BOLT CAR 5/16-18x1.250	82	8620135	ASSY. TX SERIES LOWER PLATEN LV 4.3"
29*	33022	MANUAL OWNERS TX / D-TX	83	8620136	ASSY. TXM-SS UPPER PLATEN LV 4.3"
30	33605	DECAL, UNPLUG MACHINE	84	8620332	ASSEMBLY, I/O / PWR SUPPLY DX 4.3"
31	34592	SCREW MCH 8-32x0.625 PHPH	85	8621047	M-LIMIT SWITCH MOUNT
32	37060	SWITCH ROLLER V7-1C13D8-201	86	8621064	M-WIRE CLAMP BASE
33	37125	SCREW MCH 4-40X0.625 RHPH	87	8621065	M-WIRE CLAMP CAP
34	50083	SCREW MCH 10-32X0.375 THPH SS	88	8621100	P-ASSY UPPER PLATEN MOUNT PLATE
35	50628	SCREW MCH 6-32x2.000 RHPH	89	8621111	M-HANDLE LC
36	50682	FTG 1T EL MALE 1/4Tx1/4NPT	90	8621153	M-DX JACK .5 HEX SHAFT
37	61220	ROD END 3/8-24 RH FEM	91*	8621174	DX SERIES PACKAGING
38	61247	BEARING CAM FLWR .75x.5x3/8-24	92	8621212	ASSY, UPPER HOUSING DXE 4.3" CLCD SS
39	61255	GEAR SPUR 10P-14.5A-25T	93	8621216	HOUSING, BOTTOM DXA 4.3" CLCD STAINLESS
40	61263	BUSHING TAPERED 1" ID	94	8621221	BOTTOM COVER 4.3" CLCD
41	61417	DP CYLINDER RACK	95	8621226	COVER, FRAME ARCH STAINLESS STEEL
42	61638	FUSE HOLDER S8301-1 BUSSMANN	96	8621242	ASSEMBLY, DISPLAY THREE SWITCH SS
43	61646	CYLINDER DOUBLE ACTING 3x3	97	8621261	DXA HOUSING FRAME COVER 4.3" CLCD SS
44	62251	SCREW SET 3/8-16x0.625 DP	98	89276	BOLT 3/8-16x5.000
45	62278	SCREW SET 5/16-18x0.500 NT	99	90134	SCREW CPSKT 1/4-20x0.750
46	62448	WIRE CABLE CLIP ADHESIVE BACK			
47	62537	NUT ALLEN 3/8-24			
48	62553	FTG 1T FLOW CTRL 1/4Tx1/8MPT			
49	62561	KNOB PHENOLIC CL 852-PB			
50	62693	FTG BUSHING 1/8x3/8NPT BRS			
51	62731	RELAY SS 25A 3-32VDC INPUT			
52	63711	FOOT RUBBER 1-1/2"ODx1/4"			
53	63746	SCREW SET 3/8-16x1.750			
54	63932	FTG 1T EL MALE 3/8Tx1/4NPT STL			

# REPLACEMENT PARTS LIST (TXE MODEL)

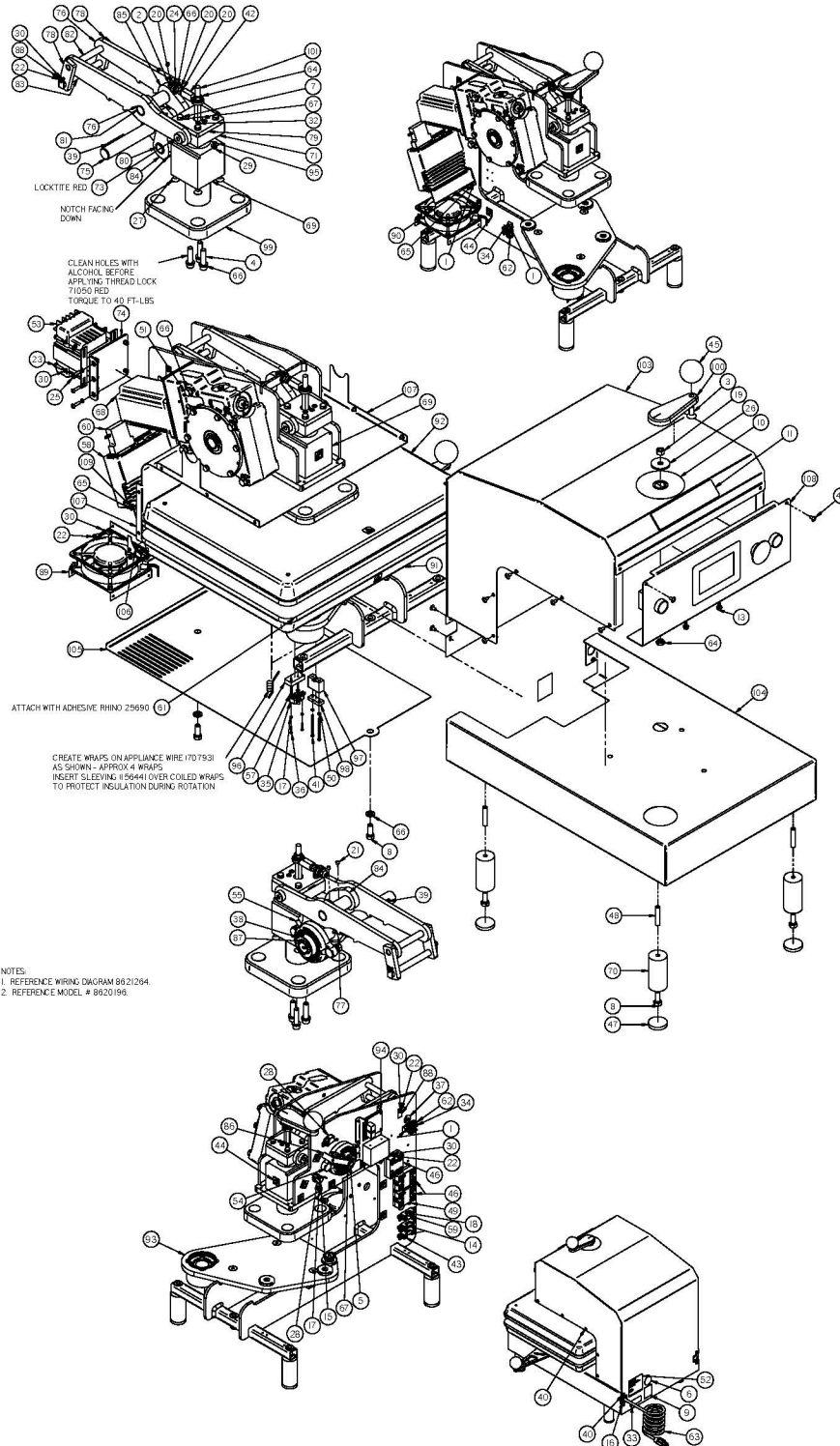

ITEM#	PART#	TITLE
109	89540	SCREW MCH 8-32x0.375 PHPH

# REPLACEMENT PARTS LIST (TXE MODEL)

ITEM#	PART#	TITLE	ITEM#	PART#	TITLE
1	10021	WASHER LOCK HEL SPR #8 ZP	55	70597	SCREW SET 5/16-24x0.625 CP
2	10024	SCREW SET 3/8-24 X 2.000	56*	70793	WIRE APPL 16GA 250C/600V NPC
3	10027	SCREW FHSKT 3/8-16X1.000 SS	57	70899	SCREW MCH 6-32X0.750 FHPH
4	10341	SCREW CPSKT 3/8-16X1.500 GD 8	58	71001	CONTROL STEPPER STAC5-Q-N220
5	10660	BOLT 1/4-20X0.500	59	71019	FUSE ABC-3
6	10664	DECAL MADE IN USA	60	71025	HARNES DB25 DXE
7	10678	BOLT 1/4-20x0.750	61	71041	SEAL SHAFT 2.500
8	10850	BOLT 3/8-16 X 1.000	62	72223	TERM BD 601-2-KT37, 38,39
9	10963	DECAL, QR CODE DXP	63	72495	CORDSET 220V 14/3 SJTOW 6-20P
10	11300	DECAL, THICK THIN	64	73247	NUT 3/8-16 JAM NYLON INSERT ZPS
11	11327	DECAL, DOUGHXPRESS DOMED 6.75 X 1.5	65	77230	NUT 8-32 ZPS
12*	11339	WIRE KIT, D-TXE-2-18 220V	66	79418	WASHER LOCK HEL SPR 3/8 ZP
13	11404	SCREW MCH 10-32X0.375 SS	67	79426	WASHER LOCK HEL SPR 1/4 ZP
14	13045	FUSE MDA-15 / 65 TS	68	8600202	ASSEMBLY, DXE GEARBOX 3
15	13103	SCREW MCH 4-40x0.750 RHSL	69	8600920	DP JACK SHAFT HOUSING ASSY.
16	13250	CORD GRIP HEYCO 1557 RDD201	70	8601083	M-DP LEG 3"
17	13919	WASHER LOCK HEL SPR #4 ZP	71	8601217	M-DXE ADJSMNT SCREW RETAINER
18	14524	SCREW MCH 4-40X0.250 PHPH	72*	8601219	M-DXE JACK ADJ STOP
19	14571	NUT 3/8-16 ZPS	73	8601220	M-DXE DRIVE PIN
20	14647	NUT HEX JAM 3/8-16 NC ZP	74	8601286	BRACKET, TRANSFORMER 70346 DXE
21	15131	SCREW SET 1/4-20x0.250	75	8603018	DXE MAIN SHAFT
22	15321	SCREW MCH 10-32x0.375 PHPH	76	8603101	DXE LINK STABILIZER
23	15347	SCREW MCH 10-24x0.750 RHPH	77	8603103	M- LINK CRANK LARGE
24	16683	WASHER FLT .375x0.875x.078 ZPS	78	8603105	DXE LINK FOLLOWER
25	24074	WASHER FLT .219x0.500x.047 ZPS	79	8603110	DXE ADJUSTMENT SCREW CAP
26	25720	WASHER FLT .406X1.500X.120 ZPS	80	8603115	PIN CRANK LARGE
27	28142	SCREW FHSKT 5/16-18x1.000	81	8603116	M- PIN ROD LARGE
28	31823	SWITCH MICRO SMALL SEMI-HOOK	82	8603117	DXE PIN STABILIZER
29	32224	SCREW SET 3/8-16x0.375 DP	83	8603118	DXE PIN FOLLOWER
30	32228	WASHER LOCK HEL SPR #10 ZP	84	8603124	LINK MAIN LARGE 1/32 CHAMFER LEFT
31*	33022	MANUAL OWNERS TX / D-TX	85	8603128	LINK MAIN LARGE 1/32 CHAMFER RIGHT
32	33071	DETENT 3/8-16X0.188 BALL	86	8603129	O-DXE SWITCH ARM
33	33605	DECAL, UNPLUG MACHINE	87	8603502	DXE MAIN SHAFT BUSHING
34	34592	SCREW MCH 8-32x0.625 PHPH	88	8603503	M-DXE PIN RETAINER
35	37060	SWITCH ROLLER V7-1C13D8-201	89	8605907	P-DP TXMSS FAN ASSY 220v
36	37125	SCREW MCH 4-40X0.625 RHPH	90	8609217	BRACKET, STAC5 MOUNTING
37	39446	GROMMET .313IDx.563 GRV	91	8620135	ASSY. TX SERIES LOWER PLATEN LV 4.3"
38	39586	BEARING 1-1/4" 2 BOLT FLANGE	92	8620136	ASSY. TXM-SS UPPER PLATEN LV 4.3"
39	39748	KEY STL .250x.250x1.75 UNDSZ	93	8620171	ASSY FRAME WITH SUPPORTS
40	50083	SCREW MCH 10-32X0.375 THPH SS	94	8620332	ASSEMBLY, I/O / PWR SUPPLY DX 4.3"
41	50628	SCREW MCH 6-32x2.000 RHPH	95	8621026	JACK SHAFT D-TXM-2-18
42	61220	ROD END 3/8-24 RH FEM	96	8621047	M-LIMIT SWITCH MOUNT
43	61638	FUSE HOLDER S8301-1 BUSSMANN	97	8621064	M-WIRE CLAMP BASE
44	62448	WIRE CABLE CLIP ADHESIVE BACK	98	8621065	M-WIRE CLAMP CAP
45	62561	KNOB PHENOLIC CL 852-PB	99	8621100	P-ASSY UPPER PLATEN MOUNT PLATE
46	62731	RELAY SS 25A 3-32VDC INPUT	100	8621111	M-HANDLE LC
47	63711	FOOT RUBBER 1-1/2"ODx1/4"	101	8621153	M-DX JACK .5 HEX SHAFT
48	63746	SCREW SET 3/8-16x1.750	102*	8621174	DX SERIES PACKAGING
49	66729	SCREW MCH 10-32x0.375 GRND	103	8621212	ASSY, UPPER HOUSING DXE 4.3" CLCD SS
50	68330	WASHER LOCK #6 SPLIT ZPS	104	8621217	HOUSING, BOTTOM 4.3" CLCD STAINLESS
51	70045	BOLT 3/8-16 X 3.750	105	8621221	BOTTOM COVER 4.3" CLCD
52	70268	DECAL HIX I.D. 3" X 3" SILVER	106	8621226	COVER, FRAME ARCH STAINLESS STEEL
53	70346	TRANSFORMER PH150MQMJ	107	8621230	DX HOUSING FRAME COVER 4.3" CLCD SS
54	70563	BOLT CAR 3/8-16x1.250	108	8621242	ASSEMBLY, DISPLAY THREE SWITCH SS

# REPLACEMENT PARTS LIST (TXM MODEL)

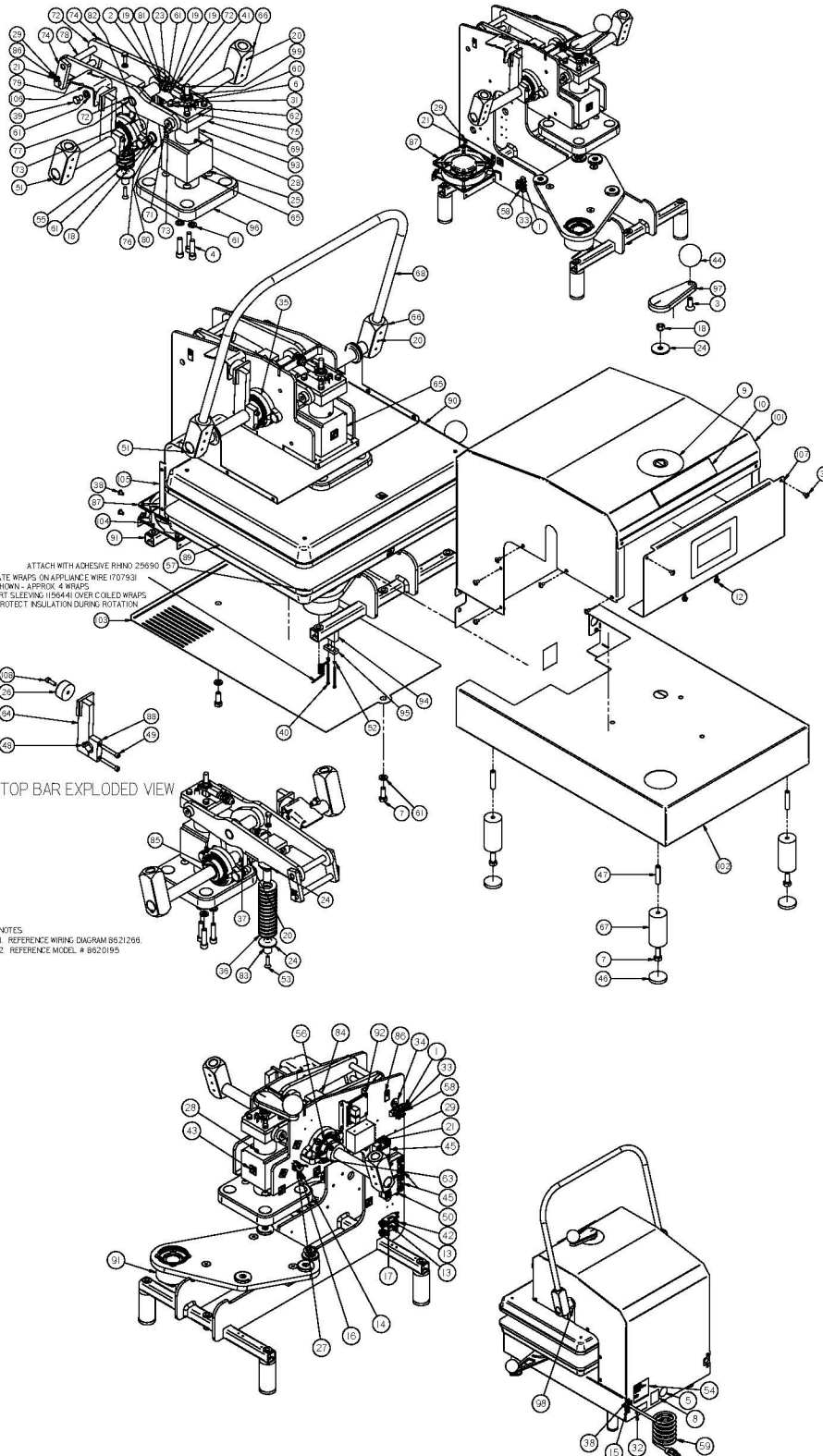

# REPLACEMENT PARTS LIST (TXM MODEL)

ITEM#	PART#	TITLE	ITEM#	PART#	TITLE
1	10021	WASHER LOCK HEL SPR #8 ZP	55	70563	BOLT CAR 3/8-16x1.250
2	10024	SCREW SET 3/8-24 X 2.000	56	70597	SCREW SET 5/16-24x0.625 CP
3	10027	SCREW FHSKT 3/8-16X1.000 SS	57	71041	SEAL SHAFT 2.500
4	10341	SCREW CPSKT 3/8-16X1.500 GD 8	58	72223	TERM BD 601-2-KT37, 38,39
5	10664	DECAL MADE IN USA	59	72495	CORDSET 220V 14/3 SJTOW 6-20P
6	10678	BOLT 1/4-20x0.750	60	73247	NUT 3/8-16 JAM NYLON INSERT ZPS
7	10850	BOLT 3/8-16 X 1.000	61	79418	WASHER LOCK HEL SPR 3/8 ZP
8	10963	DECAL, QR CODE DXP	62	79426	WASHER LOCK HEL SPR 1/4 ZP
9	11300	DECAL, THICK THIN	63	8600420	M-DXM LIMIT SWITCH WELDMENT
10	11327	DECAL, DOUGHXPRESS DOMED 6.75 X 1.5	64	8600450	DXM STOP BAR WELDMENT
11*	11342	WIRE KIT, D-TXM-2-18 4.3" 220V 4.3"	65	8600920	DP JACK SHAFT HOUSING ASSY.
12	11404	SCREW MCH 10-32X0.375 SS	66	8601081	M-DP DXM HANDLE ADAPTOR
13	13045	FUSE MDA-15 / 65 TS	67	8601083	M-DP LEG 3"
14	13103	SCREW MCH 4-40x0.750 RHSL	68	8601087	HANDLE, DXM STEEL
15	13250	CORD GRIP HEYCO 1557 RDD201	69	8601217	M-DXE ADJSMNT SCREW RETAINER
16	13919	WASHER LOCK HEL SPR #4 ZP	70*	8601219	M-DXE JACK ADJ STOP
17	14524	SCREW MCH 4-40X0.250 PHPH	71	8601220	M-DXE DRIVE PIN
18	14571	NUT 3/8-16 ZPS	72	8603101	DXE LINK STABILIZER
19	14647	NUT HEX JAM 3/8-16 NC ZP	73	8603103	M- LINK CRANK LARGE
20	15131	SCREW SET 1/4-20x0.250	74	8603105	DXE LINK FOLLOWER
21	15321	SCREW MCH 10-32x0.375 PHPH	75	8603110	DXE ADJUSTMENT SCREW CAP
22*	15644	SLEEVEING SZ 3 #710C-3BK	76	8603115	PIN CRANK LARGE
23	16683	WASHER FLT .375x0.875x.078 ZPS	77	8603116	M- PIN ROD LARGE
24	25720	WASHER FLT .406X1.500X.120 ZPS	78	8603117	DXE PIN STABILIZER
25	28142	SCREW FHSKT 5/16-18x1.000	79	8603118	DXE PIN FOLLOWER
26	31453	FOOT RUBBER 0.75x1.50x0.25	80	8603124	LINK MAIN LARGE 1/32 CHAMFER LEFT
27	31823	SWITCH MICRO SMALL SEMI-HOOK	81	8603128	LINK MAIN LARGE 1/32 CHAMFER RIGHT
28	32224	SCREW SET 3/8-16x0.375 DP	82	8603132	M-DXM PINION SHAFT
29	32228	WASHER LOCK HEL SPR #10 ZP	83	8603133	DXM SPRING HOLDER
30*	33022	MANUAL OWNERS TX / D-TX	84	8603134	SPRING PLATE UPPER
31	33071	DETENT 3/8-16X0.188 BALL	85	8603502	DXE MAIN SHAFT BUSHING
32	33605	DECAL, UNPLUG MACHINE	86	8603503	M-DXE PIN RETAINER
33	34592	SCREW MCH 8-32x0.625 PHPH	87	8605907	P-DP TXMSS FAN ASSY 220v
34	39446	GROMMET .313IDx.563 GRV	88	8609117	DXM SHAFT CLAMP
35	39586	BEARING 1-1/4" 2 BOLT FLANGE	89	8620135	ASSY. TX SERIES LOWER PLATEN LV 4.3"
36	39705	SPRING DIE M150-500	90	8620136	ASSY. TXM-SS UPPER PLATEN LV 4.3"
37	39748	KEY STL .250x.250x1.75 UNDSZ	91	8620171	ASSY FRAME WITH SUPPORTS
38	50083	SCREW MCH 10-32X0.375 THPH SS	92	8620332	ASSEMBLY, I/O / PWR SUPPLY DX 4.3"
39	50342	BOLT 3/8-16x0.500	93	8621026	JACK SHAFT D-TXM-2-18
40	50628	SCREW MCH 6-32x2.000 RHPH	94	8621064	M-WIRE CLAMP BASE
41	61220	ROD END 3/8-24 RH FEM	95	8621065	M-WIRE CLAMP CAP
42	61638	FUSE HOLDER S8301-1 BUSSMANN	96	8621100	P-ASSY UPPER PLATEN MOUNT PLATE
43	62448	WIRE CABLE CLIP ADHESIVE BACK	97	8621111	M-HANDLE LC
44	62561	KNOB PHENOLIC CL 852-PB	98	8621132	GROMMET 1.00IDX.095 GRV
45	62731	RELAY SS 25A 3-32VDC INPUT	99	8621153	M-DX JACK .5 HEX SHAFT
46	63711	FOOT RUBBER 1-1/2"ODx1/4"	100*	8621174	DX SERIES PACKAGING
47	63746	SCREW SET 3/8-16x1.750	101	8621211	ASSY, UPPER HOUSING DXM 4.3" CLCD SS
48	63916	KEY STL .250x.250x.750	102	8621217	HOUSING, BOTTOM 4.3" CLCD STAINLESS
49	65242	SCREW CPSKT 1/4-20x1.750	103	8621221	BOTTOM COVER 4.3" CLCD
50	66729	SCREW MCH 10-32x0.375 GRND	104	8621226	COVER, FRAME ARCH STAINLESS STEEL
51	67490	KEY STL .250x.250x1.50 UNDSZ	105	8621230	DX HOUSING FRAME COVER 4.3" CLCD SS
52	68330	WASHER LOCK #6 SPLIT ZPS	106	8621237	HANDLE STOP, DX SHEETMETAL
53	70077	SCREW FHSKT 1/4-20x1.000	107	8621240	ASSEMBLY, DISPLAY NO SWITCHES SS
54	70268	DECAL HIX I.D. 3" X 3" SILVER	108	90134	SCREW CPSKT 1/4-20x0.750

# REPLACEMENT PARTS LIST (D-TXA-2-18 MODEL)

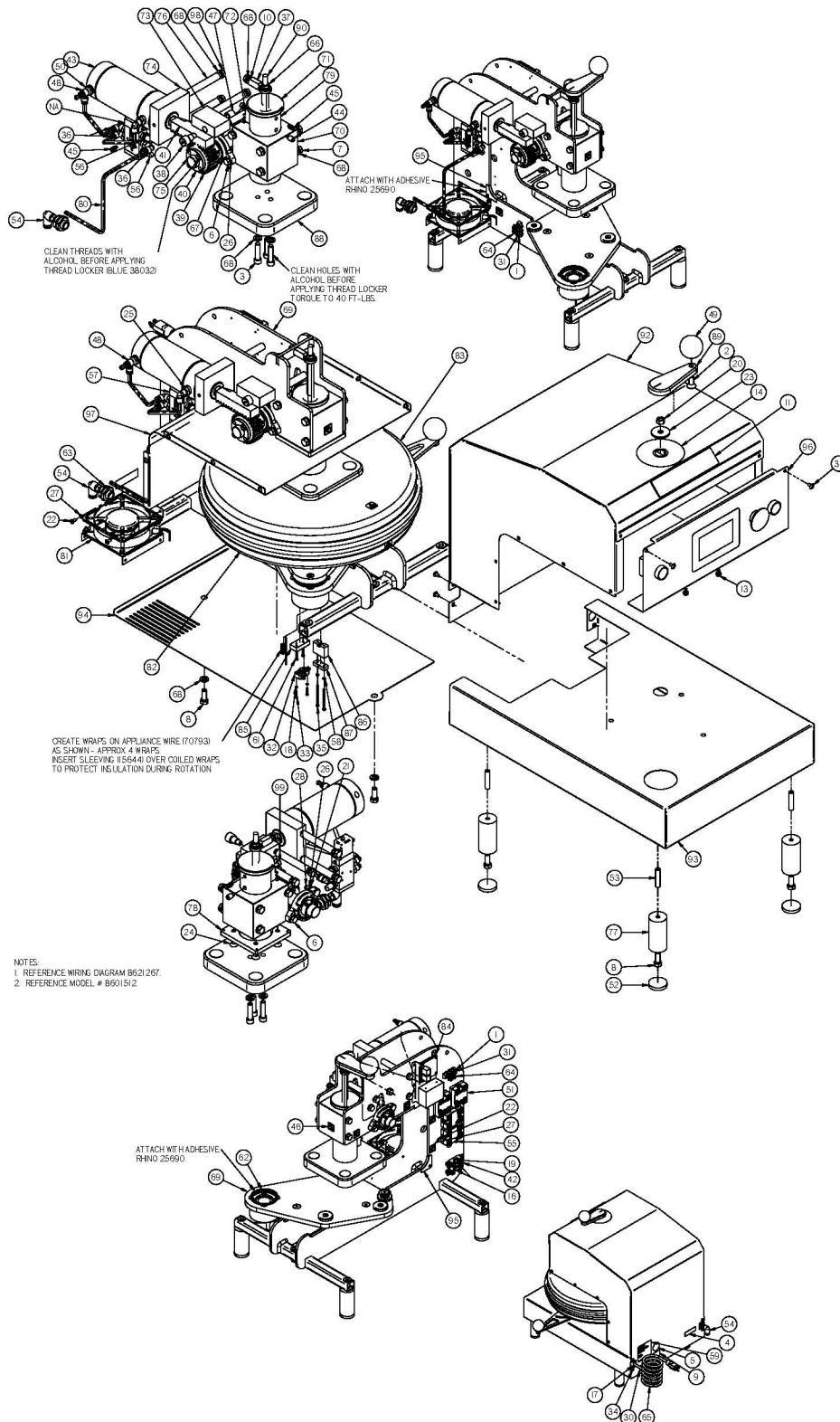

# REPLACEMENT PARTS LIST

## (D-TXA-2-18 MODEL)

ITEM#	PART#	TITLE	ITEM#	PART#	TITLE
1	10021	WASHER LOCK HEL SPR #8 ZP	55	66729	SCREW MCH 10-32x0.375 GRND
2	10027	SCREW FHSKT 3/8-16X1.000 SS	56	67776	FTG MUFFLER 1/4NPT SINT BRZ
3	10341	SCREW CPSKT 3/8-16X1.500 GD 8	57	68101	VALVE SOLENOID 5/2 220V 1/4NPT
4	10454	DECAL CLEAN AIR	58	68330	WASHER LOCK #6 SPLIT ZPS
5	10664	DECAL MADE IN USA	59	70268	DECAL HIX I.D. 3" X 3" SILVER
6	10777	BOLT 5/16-18x1-1/4	60*	70793	WIRE APPL 16GA 250C/600V NPC
7	10843	BOLT 3/8-16X0.750	61	70899	SCREW MCH 6-32X0.750 FHPH
8	10850	BOLT 3/8-16 X 1.000	62	71041	SEAL SHAFT 2.500
9	10963	DECAL, QR CODE DXP	63	71161	FTG BULKHD 1/4NPT BRS
10	11072	BOLT 3/8-24x1.000	64	72223	TERM BD 601-2-KT37, 38,39
11	11327	DECAL, DOUGHXPRESS DOMED 6.75 X 1.5	65	72495	CORDSET 220V 14/3 SJTOW 6-20P
12*	11344	WIRE CUT LIST TXA 16X20 220V 4.3"	66	73247	NUT 3/8-16 JAM NYLON INSERT ZPS
13	11404	SCREW MCH 10-32X0.375 SS	67	76141	BEARING 1" 2 BOLT FLANGE
14	11430	DECAL, THICK THIN DXA 4.3"	68	79418	WASHER LOCK HEL SPR 3/8 ZP
15*	11544	CABLE TIE CT4S-M 3-3/4	69	8600221	ASSEMBLY FRAME WITH SUPPORTS LV
16	13045	FUSE MDA-15 / 65 TS	70	8601034	DP JACK HOUSING
17	13250	CORD GRIP HEYCO 1557 RDD201	71	8601036	DP STOP JACK ADJUSTABLE
18	13919	WASHER LOCK HEL SPR #4 ZP	72	8601037	DP JACK RACK
19	14524	SCREW MCH 4-40X0.250 PHPH	73	8601039	DP CAM ROLLER MOUNT BLOCK
20	14571	NUT 3/8-16 ZPS	74	8601042	DP MOUNT CYLINDER / SET SCREW
21	14605	NUT 5/16-18 ZPS	75	8601043	DP PINION SHAFT
22	15321	SCREW MCH 10-32x0.375 PHPH	76	8601067	DP SPACER FRAME PINION
23	25720	WASHER FLT .406X1.500X.120 ZPS	77	8601083	M-DP LEG 3"
24	28142	SCREW FHSKT 5/16-18x1.000	78	8601085	SPACER HOUSING FRAME COVER DXA
25	28630	FTG 1T EL MALE 1/4Tx3/8NPT	79	8601409	JACK SHAFT DXA LV
26	30910	WASHER LOCK HEL SPR 5/16 ZP	80	8601952	TUBE 0.250ODx0.167ID 9.75
27	32228	WASHER LOCK HEL SPR #10 ZP	81	8605907	P-DP TXMSS FAN ASSY 220v
28	32680	BOLT CAR 5/16-18x1.250	82	8620089	ASSY. DP LOWER PLATEN 18 IN. DIA. HEATED
29*	33022	MANUAL OWNERS TX / D-TX	83	8620128	ASSY. DX-2-18 UPPER PLATEN LV 4.3" CLCD
30	33605	DECAL, UNPLUG MACHINE	84	8620332	ASSEMBLY, I/O / PWR SUPPLY DX 4.3"
31	34592	SCREW MCH 8-32x0.625 PHPH	85	8621047	M-LIMIT SWITCH MOUNT
32	37060	SWITCH ROLLER V7-1C13D8-201	86	8621064	M-WIRE CLAMP BASE
33	37125	SCREW MCH 4-40X0.625 RHPH	87	8621065	M-WIRE CLAMP CAP
34	50083	SCREW MCH 10-32X0.375 THPH SS	88	8621100	P-ASSY UPPER PLATEN MOUNT PLATE
35	50628	SCREW MCH 6-32x2.000 RHPH	89	8621111	M-HANDLE LC
36	50682	FTG 1T EL MALE 1/4Tx1/4NPT	90	8621153	M-DX JACK .5 HEX SHAFT
37	61220	ROD END 3/8-24 RH FEM	91*	8621174	DX SERIES PACKAGING
38	61247	BEARING CAM FLWR .75x.5x3/8-24	92	8621212	ASSY, UPPER HOUSING DXE 4.3" CLCD SS
39	61255	GEAR SPUR 10P-14.5A-25T	93	8621216	HOUSING, BOTTOM DXA 4.3" CLCD STAINLESS
40	61263	BUSHING TAPERED 1" ID	94	8621221	BOTTOM COVER 4.3" CLCD
41	61417	DP CYLINDER RACK	95	8621226	COVER, FRAME ARCH STAINLESS STEEL
42	61638	FUSE HOLDER S8301-1 BUSSMANN	96	8621242	ASSEMBLY, DISPLAY THREE SWITCH SS
43	61646	CYLINDER DOUBLE ACTING 3x3	97	8621261	DXA HOUSING FRAME COVER 4.3" CLCD SS
44	62251	SCREW SET 3/8-16x0.625 DP	98	89276	BOLT 3/8-16x5.000
45	62278	SCREW SET 5/16-18x0.500 NT	99	90134	SCREW CPSKT 1/4-20x0.750
46	62448	WIRE CABLE CLIP ADHESIVE BACK			
47	62537	NUT ALLEN 3/8-24			
48	62553	FTG 1T FLOW CTRL 1/4Tx1/8MPT			
49	62561	KNOB PHENOLIC CL 852-PB			
50	62693	FTG BUSHING 1/8x3/8NPT BRS			
51	62731	RELAY SS 25A 3-32VDC INPUT			
52	63711	FOOT RUBBER 1-1/2"ODx1/4"			
53	63746	SCREW SET 3/8-16x1.750			
54	63932	FTG 1T EL MALE 3/8Tx1/4NPT STL			

# REPLACEMENT PARTS LIST (D-TXE-2-18 MODEL)

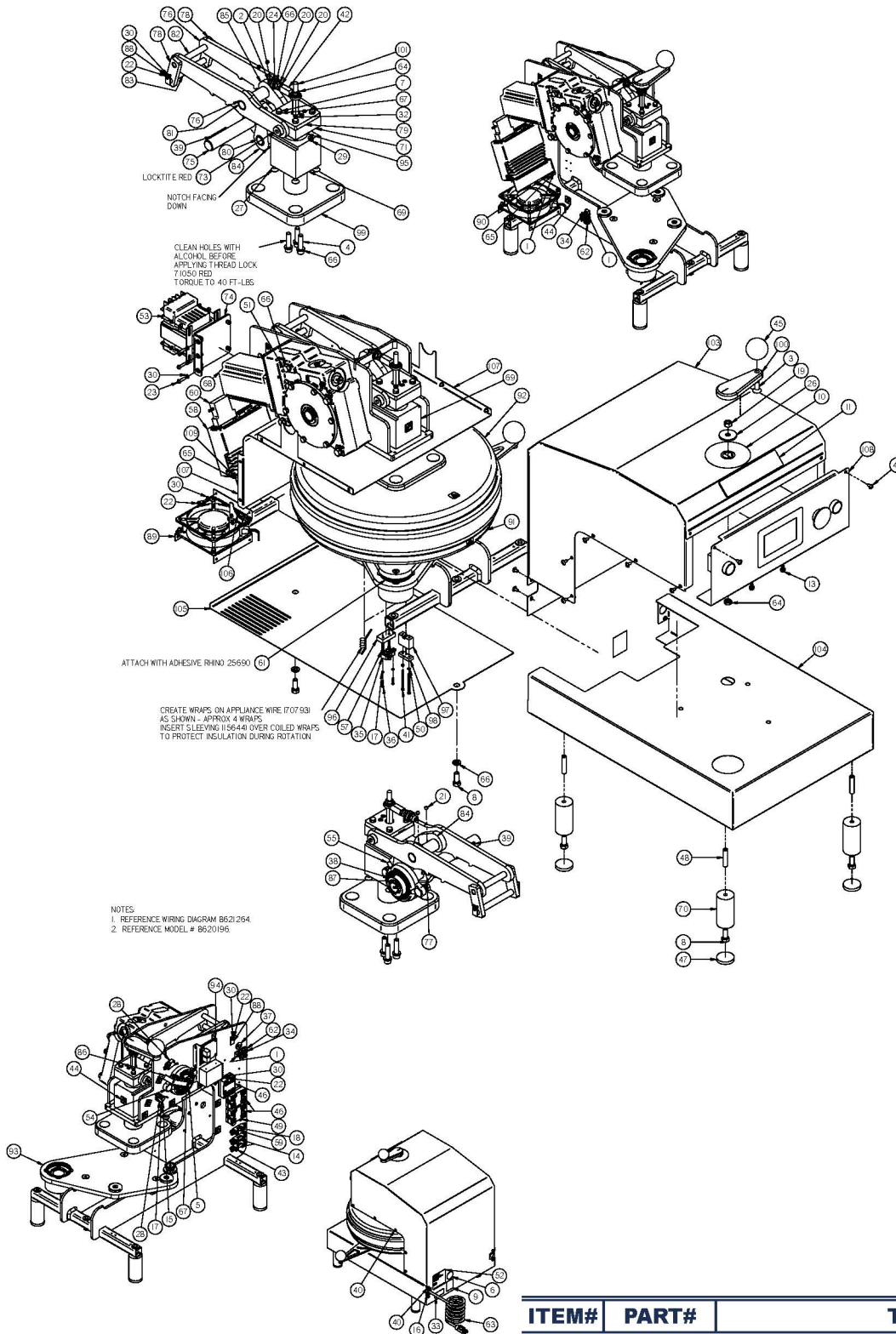

ITEM#	PART#	TITLE
109	89540	SCREW MCH 8-32x0.375 PHPH

# REPLACEMENT PARTS LIST

## (D-TXE-2-18 MODEL)

ITEM#	PART#	TITLE	ITEM#	PART#	TITLE
1	10021	WASHER LOCK HEL SPR #8 ZP	55	70597	SCREW SET 5/16-24x0.625 CP
2	10024	SCREW SET 3/8-24 X 2.000	56*	70793	WIRE APPL 16GA 250C/600V NPC
3	10027	SCREW FHSKT 3/8-16X1.000 SS	57	70899	SCREW MCH 6-32X0.750 FHPH
4	10341	SCREW CPSKT 3/8-16X1.500 GD 8	58	71001	CONTROL STEPPER STAC5-Q-N220
5	10660	BOLT 1/4-20X0.500	59	71019	FUSE ABC-3
6	10664	DECAL MADE IN USA	60	71025	HARNES DB25 DXE
7	10678	BOLT 1/4-20x0.750	61	71041	SEAL SHAFT 2.500
8	10850	BOLT 3/8-16 X 1.000	62	72223	TERM BD 601-2-KT37, 38,39
9	10963	DECAL, QR CODE DXP	63	72495	CORDSET 220V 14/3 SJTOW 6-20P
10	11300	DECAL, THICK THIN	64	73247	NUT 3/8-16 JAM NYLON INSERT ZPS
11	11327	DECAL, DOUGHXPRESS DOMED 6.75 X 1.5	65	77230	NUT 8-32 ZPS
12*	11339	WIRE KIT, D-TXE-2-18 220V	66	79418	WASHER LOCK HEL SPR 3/8 ZP
13	11404	SCREW MCH 10-32X0.375 SS	67	79426	WASHER LOCK HEL SPR 1/4 ZP
14	13045	FUSE MDA-15 / 65 TS	68	8600202	ASSEMBLY, DXE GEARBOX 3
15	13103	SCREW MCH 4-40x0.750 RHSL	69	8600920	DP JACK SHAFT HOUSING ASSY.
16	13250	CORD GRIP HEYCO 1557 RDD201	70	8601083	M-DP LEG 3"
17	13919	WASHER LOCK HEL SPR #4 ZP	71	8601217	M-DXE ADJSMNT SCREW RETAINER
18	14524	SCREW MCH 4-40X0.250 PHPH	72*	8601219	M-DXE JACK ADJ STOP
19	14571	NUT 3/8-16 ZPS	73	8601220	M-DXE DRIVE PIN
20	14647	NUT HEX JAM 3/8-16 NC ZP	74	8601286	BRACKET, TRANSFORMER 70346 DXE
21	15131	SCREW SET 1/4-20x0.250	75	8603018	DXE MAIN SHAFT
22	15321	SCREW MCH 10-32x0.375 PHPH	76	8603101	DXE LINK STABILIZER
23	15347	SCREW MCH 10-24x0.750 RHPH	77	8603103	M- LINK CRANK LARGE
24	16683	WASHER FLT .375x0.875x.078 ZPS	78	8603105	DXE LINK FOLLOWER
25*	24074	WASHER FLT .219x0.500x.047 ZPS	79	8603110	DXE ADJUSTMENT SCREW CAP
26	25720	WASHER FLT .406X1.500X.120 ZPS	80	8603115	PIN CRANK LARGE
27	28142	SCREW FHSKT 5/16-18x1.000	81	8603116	M- PIN ROD LARGE
28	31823	SWITCH MICRO SMALL SEMI-HOOK	82	8603117	DXE PIN STABILIZER
29	32224	SCREW SET 3/8-16x0.375 DP	83	8603118	DXE PIN FOLLOWER
30	32228	WASHER LOCK HEL SPR #10 ZP	84	8603124	LINK MAIN LARGE 1/32 CHAMFER LEFT
31*	33022	MANUAL OWNERS TX / D-TX	85	8603128	LINK MAIN LARGE 1/32 CHAMFER RIGHT
32	33071	DETENT 3/8-16X0.188 BALL	86	8603129	O-DXE SWITCH ARM
33	33605	DECAL, UNPLUG MACHINE	87	8603502	DXE MAIN SHAFT BUSHING
34	34592	SCREW MCH 8-32x0.625 PHPH	88	8603503	M-DXE PIN RETAINER
35	37060	SWITCH ROLLER V7-1C13D8-201	89	8605907	P-DP TXMSS FAN ASSY 220v
36	37125	SCREW MCH 4-40X0.625 RHPH	90	8609217	BRACKET, STAC5 MOUNTING
37	39446	GROMMET .313IDx.563 GRV	91	8620089	ASSY. DP LOWER PLATEN 18 IN. DIA. HEATED
38	39586	BEARING 1-1/4" 2 BOLT FLANGE	92	8620128	ASSY. DX-2-18 UPPER PLATEN LV 4.3" CLCD
39	39748	KEY STL .250x.250x1.75 UNDSZ	93	8620171	ASSY FRAME WITH SUPPORTS
40	50083	SCREW MCH 10-32X0.375 THPH SS	94	8620332	ASSEMBLY, I/O / PWR SUPPLY DX 4.3"
41	50628	SCREW MCH 6-32x2.000 RHPH	95	8621026	JACK SHAFT D-TXM-2-18
42	61220	ROD END 3/8-24 RH FEM	96	8621047	M-LIMIT SWITCH MOUNT
43	61638	FUSE HOLDER S8301-1 BUSSMANN	97	8621064	M-WIRE CLAMP BASE
44	62448	WIRE CABLE CLIP ADHESIVE BACK	98	8621065	M-WIRE CLAMP CAP
45	62561	KNOB PHENOLIC CL 852-PB	99	8621100	P-ASSY UPPER PLATEN MOUNT PLATE
46	62731	RELAY SS 25A 3-32VDC INPUT	100	8621111	M-HANDLE LC
47	63711	FOOT RUBBER 1-1/2"ODx1/4"	101	8621153	M-DX JACK .5 HEX SHAFT
48	63746	SCREW SET 3/8-16x1.750	102*	8621174	DX SERIES PACKAGING
49	66729	SCREW MCH 10-32x0.375 GRND	103	8621212	ASSY, UPPER HOUSING DXE 4.3" CLCD SS
50	68330	WASHER LOCK #6 SPLIT ZPS	104	8621217	HOUSING, BOTTOM 4.3" CLCD STAINLESS
51	70045	BOLT 3/8-16 X 3.750	105	8621221	BOTTOM COVER 4.3" CLCD
52	70268	DECAL HIX I.D. 3" X 3" SILVER	106	8621226	COVER, FRAME ARCH STAINLESS STEEL
53	70346	TRANSFORMER PH150MQMJ	107	8621230	DX HOUSING FRAME COVER 4.3" CLCD SS
54	70563	BOLT CAR 3/8-16x1.250	108	8621242	ASSEMBLY, DISPLAY THREE SWITCH SS

# REPLACEMENT PARTS LIST (D-TXM-2-18 MODEL)

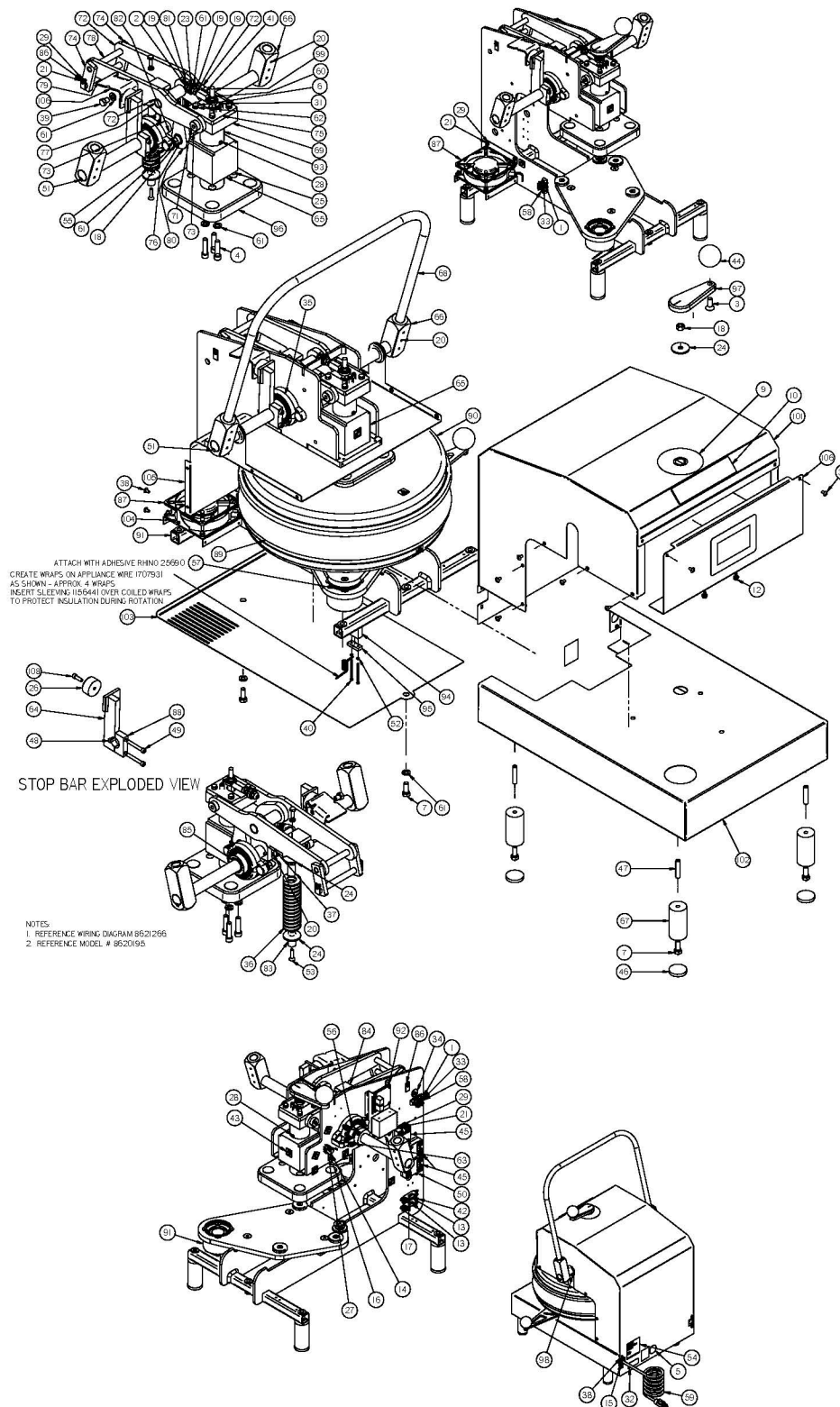

# REPLACEMENT PARTS LIST

## (D-TXM-2-18 MODEL)

ITEM#	PART#	TITLE	ITEM#	PART#	TITLE
1	10021	WASHER LOCK HEL SPR #8 ZP	55	70563	BOLT CAR 3/8-16x1.250
2	10024	SCREW SET 3/8-24 X 2.000	56	70597	SCREW SET 5/16-24x0.625 CP
3	10027	SCREW FHSKT 3/8-16X1.000 SS	57	71041	SEAL SHAFT 2.500
4	10341	SCREW CPSKT 3/8-16X1.500 GD 8	58	72223	TERM BD 601-2-KT37, 38,39
5	10664	DECAL MADE IN USA	59	72495	CORDSET 220V 14/3 SJTOW 6-20P
6	10678	BOLT 1/4-20x0.750	60	73247	NUT 3/8-16 JAM NYLON INSERT ZPS
7	10850	BOLT 3/8-16 X 1.000	61	79418	WASHER LOCK HEL SPR 3/8 ZP
8	10963	DECAL, QR CODE DXP	62	79426	WASHER LOCK HEL SPR 1/4 ZP
9	11300	DECAL, THICK THIN	63	8600420	M-DXM LIMIT SWITCH WELDMENT
10	11327	DECAL, DOUGHXPRESS DOMED 6.75 X 1.5	64	8600450	DXM STOP BAR WELDMENT
11	11342	WIRE KIT, D-TXM-2-18 4.3" 220V 4.3"	65	8600920	DP JACK SHAFT HOUSING ASSY.
12	11404	SCREW MCH 10-32X0.375 SS	66	8601081	M-DP DXM HANDLE ADAPTOR
13	13045	FUSE MDA-15 / 65 TS	67	8601083	M-DP LEG 3"
14	13103	SCREW MCH 4-40x0.750 RHSL	68	8601087	HANDLE, DXM STEEL
15	13250	CORD GRIP HEYCO 1557 RDD201	69	8601217	M-DXE ADJSMNT SCREW RETAINER
16	13919	WASHER LOCK HEL SPR #4 ZP	70	8601219	M-DXE JACK ADJ STOP
17	14524	SCREW MCH 4-40X0.250 PHPH	71	8601220	M-DXE DRIVE PIN
18	14571	NUT 3/8-16 ZPS	72	8603101	DXE LINK STABILIZER
19	14647	NUT HEX JAM 3/8-16 NC ZP	73	8603103	M- LINK CRANK LARGE
20	15131	SCREW SET 1/4-20x0.250	74	8603105	DXE LINK FOLLOWER
21	15321	SCREW MCH 10-32x0.375 PHPH	75	8603110	DXE ADJUSTMENT SCREW CAP
22	15644	SLEEVEING SZ 3 #710C-3BK	76	8603115	PIN CRANK LARGE
23	16683	WASHER FLT .375x0.875x.078 ZPS	77	8603116	M- PIN ROD LARGE
24	25720	WASHER FLT .406X1.500X.120 ZPS	78	8603117	DXE PIN STABILIZER
25	28142	SCREW FHSKT 5/16-18x1.000	79	8603118	DXE PIN FOLLOWER
26	31453	FOOT RUBBER 0.75x1.50x0.25	80	8603124	LINK MAIN LARGE 1/32 CHAMFER LEFT
27	31823	SWITCH MICRO SMALL SEMI-HOOK	81	8603128	LINK MAIN LARGE 1/32 CHAMFER RIGHT
28	32224	SCREW SET 3/8-16x0.375 DP	82	8603132	M-DXM PINION SHAFT
29	32228	WASHER LOCK HEL SPR #10 ZP	83	8603133	DXM SPRING HOLDER
30*	33022	MANUAL OWNERS TX / D-TX	84	8603134	SPRING PLATE UPPER
31	33071	DETENT 3/8-16X0.188 BALL	85	8603502	DXE MAIN SHAFT BUSHING
32	33605	DECAL, UNPLUG MACHINE	86	8603503	M-DXE PIN RETAINER
33	34592	SCREW MCH 8-32x0.625 PHPH	87	8605907	P-DP TXMSS FAN ASSY 220v
34	39446	GROMMET .313IDx.563 GRV	88	8609117	DXM SHAFT CLAMP
35	39586	BEARING 1-1/4" 2 BOLT FLANGE	89	8620089	ASSY. DP LOWER PLATEN 18 IN. DIA. HEATED
36	39705	SPRING DIE M150-500	90	8620128	ASSY. DX-2-18 UPPER PLATEN LV 4.3" CLCD
37	39748	KEY STL .250x.250x1.75 UNDSZ	91	8620171	ASSY FRAME WITH SUPPORTS
38	50083	SCREW MCH 10-32X0.375 THPH SS	92	8620332	ASSEMBLY, I/O / PWR SUPPLY DX 4.3"
39	50342	BOLT 3/8-16x0.500	93	8621026	JACK SHAFT D-TXM-2-18
40	50628	SCREW MCH 6-32x2.000 RHPH	94	8621064	M-WIRE CLAMP BASE
41	61220	ROD END 3/8-24 RH FEM	95	8621065	M-WIRE CLAMP CAP
42	61638	FUSE HOLDER S8301-1 BUSSMANN	96	8621100	P-ASSY UPPER PLATEN MOUNT PLATE
43	62448	WIRE CABLE CLIP ADHESIVE BACK	97	8621111	M-HANDLE LC
44	62561	KNOB PHENOLIC CL 852-PB	98	8621132	GROMMET 1.00IDX.095 GRV
45	62731	RELAY SS 25A 3-32VDC INPUT	99	8621153	M-DX JACK .5 HEX SHAFT
46	63711	FOOT RUBBER 1-1/2"ODx1/4"	100	8621174	DX SERIES PACKAGING
47	63746	SCREW SET 3/8-16x1.750	101	8621211	ASSY, UPPER HOUSING DXM 4.3" CLCD SS
48	63916	KEY STL .250x.250x.750	102	8621217	HOUSING, BOTTOM 4.3" CLCD STAINLESS
49	65242	SCREW CPSKT 1/4-20x1.750	103	8621221	BOTTOM COVER 4.3" CLCD
50	66729	SCREW MCH 10-32x0.375 GRND	104	8621226	COVER, FRAME ARCH STAINLESS STEEL
51	67490	KEY STL .250x.250x1.50 UNDSZ	105	8621230	DX HOUSING FRAME COVER 4.3" CLCD SS
52	68330	WASHER LOCK #6 SPLIT ZPS	106	8621237	HANDLE STOP, DX SHEETMETAL
53	70077	SCREW FHSKT 1/4-20x1.000	107	8621240	ASSEMBLY, DISPLAY NO SWITCHES SS
54	70268	DECAL HIX I.D. 3" X 3" SILVER	108	90134	SCREW CPSKT 1/4-20x0.750

# WARRANTY

**BEFORE warranty repair you MUST get Prior Authorization: Call 1-800-835-0606 Warranty will be voided otherwise.**

doughXpress® will automatically register the equipment on the date it was shipped to you or your distributor. If the equipment was not purchased directly from HIX, but through a distributor, please keep a copy of their sales invoice showing the serial number and date it was sold/shipped to you with this warranty.

In this case, we will use the distributor's invoice date as the beginning warranty date. **STAPLE A COPY OF YOUR RECEIPT TO THIS WARRANTY** and keep in a safe place to provide verification of your warranty should a problem occur. Thank you.

Please fill in the following information and attach a copy of your receipt for your records.

**Date Purchased:** \_\_\_\_\_ **From:** \_\_\_\_\_

**Model #:** \_\_\_\_\_ **Serial #:** \_\_\_\_\_

This warranty applies to equipment manufactured by the HIX Corporation (HIX), Pittsburg, Kansas, U.S.A. HIX warrants to the original purchaser, the full line of doughXpress® product against defects in workmanship and material, except for wear and tear for a period of one year parts and labor limited warranty on most items, there are selected items which may carry a two year warranty (refer to owners manual.) All dough press carts, compressors, and accessories are warranted for 90 days from the date of purchase. Repairs include parts and labor only, excluding is the following:

1. Overtime Labor Rates
2. Expedited Freight for Parts
3. doughXpress® assumes no responsibility for down time or loss of product. All defective parts must be returned to doughXpress® for credit. Repairs must be pre-authorized by doughXpress® prior to work commencing.
4. Travel time is not covered by doughXpress®, unless pre-authorized by doughXpress®. In the event of a defect, doughXpress®, at its option, will repair, replace or substitute the defective item at no cost during this period subject to the limitations of insurance and shipping costs stated below.

This warranty does not cover normal wear and tear, damages due to accident, misuse/abuse, alterations or damage due to neglect, or lack of proper lubrication or maintenance. doughXpress® shall not be responsible for repairs or alterations made by any person without the prior written authorization by doughXpress®. This warranty is the sole and exclusive warranty of doughXpress® and no person, agent, distributor, or dealer of doughXpress® is authorized to change, amend or modify the terms set forth herein, in whole or in part.

In the case of a problem with the equipment identified herein, doughXpress® should be contacted during regular business hours to discuss the problem and verify an existing warranty. doughXpress® personnel will assist the customer to correct any problems which can be corrected through operation or maintenance instructions, simple mechanical adjustments, or replacement of parts. In the event the problem cannot be corrected by phone, and upon the issuance of a return authorization by doughXpress®, the equipment shall be returned to doughXpress® or an authorized service representative. All insurance, packaging and shipment/freight costs are solely the responsibility of the customer, and doughXpress® shall not be responsible for improper handling or damage in transit.

doughXpress® customer service personnel may be contacted for complete return authorization and reconditioning information. This expressed warranty is given in lieu of any and all other warranties, whether expressed or implied, including but not limited to those of merchantability and fitness for a particular purpose, and constitutes the only warranty made by doughXpress®. In no event shall doughXpress®' liability for breach of warranty extend beyond the obligation to repair or replace the nonconforming goods. doughXpress® shall not be liable for any other damages, either incidental or consequential, or the action as brought in contract, negligence or otherwise.

This warranty gives you specific legal rights and you may also have other rights which vary from state to state.



1201 E. 27th Terrace • Pittsburg, KS 66762 • U.S.A.

Phone: (800) 835-0606 • Fax: 620-231-1598

Web site: [hixcorp.com](http://hixcorp.com) • E-Mail: [sales@hixcorp.com](mailto:sales@hixcorp.com)