

# OPERATOR'S MANUAL

## 2 Sided Grills

DXP-PS1577, DXP-PS157, DXP-CS1577, DXP-CS157

**doughXpress.**

HIX® CORPORATION COMMERCIAL FOOD DIVISION

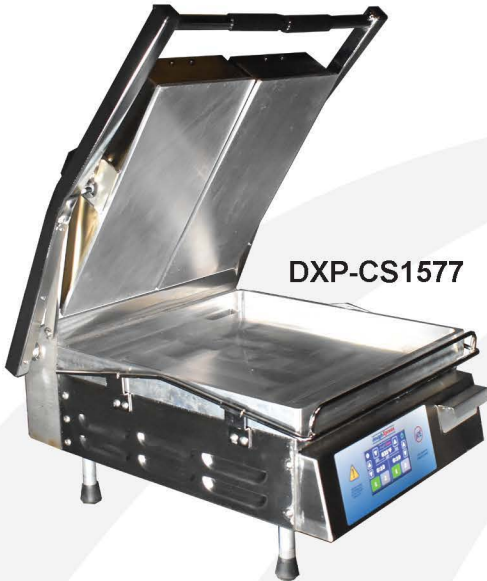

DXP-CS1577



DXP-PS1577



DXP-CS157



DXP-PS157

For Customer Service:  
Call 1-800-835-0606 or Visit [hixcorp.com](http://hixcorp.com)

**HIX** CORPORATION



# CONTENTS

<i>Receiving &amp; Setup</i> .....	3
<i>Power</i> .....	4
<i>Users Adjustable Settings</i> .....	5
<i>Machine Presets</i> .....	6
<i>Cleaning &amp; Sanitation</i> .....	7
<i>Parts List</i> .....	8
<i>Warranty</i> .....	16

BEFORE warranty repair you MUST get Prior Authorization



Intertek



Intertek

# RECEIVING & SETUP

## PLATEN SURFACE

Slight surface imperfections are a normal part of the aluminum casting process for the platens on your press. These are not considered a defect and do not affect the functionality of the machine in any way.

**NOTE:** Upon receiving your new equipment, some debris or residue may be present on the aluminum platen(s). Clean the platens per the instructions provided prior to first use.

## SHIPPING OR RETURNS

**\*NOTE\*** Save all of your shipping/packing material. Do not risk costly shipping damage, ship only in original box.

1. Fasten machine to plywood shipping base with shrink wrap.
2. Tie or tape handle securely to base.
3. Place in original box, and put side liner and top liner in place. Fold flaps and seal the box.  
(Additional bottom boards, box and liners may be obtained from your supplier for a nominal cost.)

## UNPACKING

Remember to save all packing material - including box, liner and board. You may need these for shipping your machine or if a repair is necessary in the future.

## INSPECTION

Inspect your machine for hidden shipping damage. Contact the delivery company immediately, should you find damage.

## INSTALLATION

1. Lift press from box and place on the service table or counter-top.

**CAUTION:** Heavy lifting can cause injury. We recommend two person lifting or use of a mechanical aid when handling this press. Remember to always maintain natural curves of back and bend knees to lift.

2. Install the press on the counter-top so there is no more than 3" (75mm) of horizontal distance from the counter's edge or point of access for cleaning. Minimum clearance between a wall and sides of the machine is 1".
3. Plug the cord of the press into a correctly grounded electrical outlet. The correct voltage is indicated on the identification tag of the press.

**WARNING:** Do not use an extension cord to supply power to your press.

4. The DXP-PS-1577 and DXP-CS-1577 machines are designed to have 3" legs to comply with the NSF-4 sanitation standard. Customer is responsible for compliance to safety standards.
5. Before removing wrap from handle and platens, remove bag attached to handle. Four leg extensions with threaded studs are included in a bag attached to the handle (part #1180025 & #50012) These are included to provide additional clearance for cleaning under the machine and are to be installed on existing shipping legs.

1. To install the leg extensions, remove the rubber foot from each existing leg and attach the leg extension to the existing foot. (Do not disconnect existing leg that was installed at the factory. The extension is intended to be attached to existing foot.)
2. After attaching extensions, reinstall the rubber foot on the new leg extension.

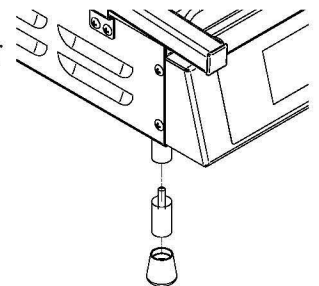

# POWER

## TURNING THE POWER “ON”

1. Once the machine is plugged into power, the display will show a “Red Icon” as shown below. To turn the power on, simply press the Red Icon.



2. The display will then come on and look like what is shown below. To turn the machine “OFF”, simply press the Green “Power” Icon in the upper right corner of the display and the unit will turn “OFF”.



To adjust the temperature simply press the “UP” or “DOWN” buttons located toward the top of the screen to change the temperature value. Maximum temperature is 525°F.

To adjust the timer settings simply press the “UP” or “DOWN” buttons located at the left and right edges of the screen to change the values.

As the temperature is warming up from a cold start, you will see three horizontal lines as shown above. These lines represent a “Heater ON” light for each of the three heat platens. The two shorter lines are the upper left and upper right platens. The longer line at the bottom represents the lower platen.

Once the temperatures of each platen gets close to the setpoint temperature selected, they will start flashing indicating when power is being supplied to each heater element to maintain the set temperature.

When the actual combined platen temperatures all reach the temperature setpoint, the controller will BEEP indicating that the grill is ready to use.

# USER ADJUSTABLE SETTINGS

## USER ADJUSTABLE SETTINGS

Pressing the “GEAR”  Icon in the upper left corner of the home screen will switch the screen to what is shown below for the user adjustable settings.



Pressing the “Back Arrow/Return” Icon in the upper left corner of the display will take you to the previous screen.

Pressing the “Home” Icon in the upper right corner of the display will take you to the “HOME” screen.

Once you have made the desired adjustments, press the “Return” or “Home” Icon.

Any changes in any of the settings or values you have made will be automatically stored as you leave that screen.

# MACHINE PRESETS

## STORING PRESETS FOR TIME & TIMER OPERATION

The controller has “TWO” independent timers - one for each side of the grill.

Each timer can save TWO time presets.

The button that is highlighted in “GREEN” is the ACTIVE timer preset on the controller. See below.



To “Start” the timer, press the Green Timer Preset button - you will see the time in the timer display window starting to count down and the active preset button will begin flashing alternating between Green and Gray.

After the designated time has elapsed, the active preset button will start flashing YELLOW as shown below and the controller will start to beep.

To Stop and reset the timer, press the flashing YELLOW button. If at any time during the countdown cycle you wish to stop the cycle (while the button is flashing GREEN), simply press the flashing button and the timer will stop and reset.

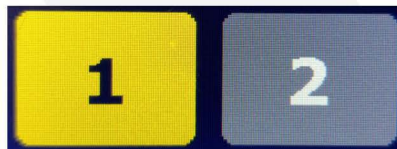

If you wish to make an adjustment to the time stored in a preset, simply press the UP/DOWN button next to the Time window to change the value to the new setting desired. The new time setting will “Autosave” in the preset button that is highlighted GREEN.

If you wish to select a different Timer Preset - just press a different preset button to select it. When the button isn’t flashing GREEN, you can select a different amount of time for that preset location and it will automatically store that new time setting.

# CLEANING & SANITATION

**WARNING:** Before cleaning, performing maintenance or repairs make sure the machine is turned off and the machine is unplugged.

**\*\*\*This appliance is not waterproof. Never spray or pour water or any other cleaning solution onto this appliance.\*\*\***

## CLEANING ALUMINUM UNCOATED HEAT PLATEN(S)

1. Unplug the machine and allow it to cool.
2. Open the heat platen for easier access.
3. Dampen a nonmetallic scrubbing sponge with a mild soap or detergent to remove any excess material from the heat platen(s).
4. Wipe clean with a dry cloth.

## CLEANING OUTSIDE SURFACES OF THE MACHINE

Use a mild soap and warm water applied with a soft cloth or sponge. Do not use steel wool, scrub sponges, kitchen or oven cleaners or other abrasives that will damage the painted surface.



# REPLACEMENT PARTS LIST

## (DXP-PS-1577 MODEL)

ITEM#	PART#	TITLE	ITEM#	PART#	TITLE
1	986242	RETAINING RING EXT 0.750 E SS	55	11146	TORSION SPRING RIGHT SIDE
2	87619	NUT 5/16-18 JAM	56	11145	TORSION SPRING LEFT SIDE
3	86702	SCREW CPSKT 3/8-16x0.875	57	11141	SPRING, COMPRESSION DIE 0.500 X 0.28125
4	79426	WASHER LOCK HEL SPR 1/4 ZP	58	11140	SCREW SET 5/16-18 X .375
5	74674	TERM 18-14 RING 10 NON M	59	10963	DECAL, QR CODE DXP
6	70861	NUT 6-32 NYLON INSERT ZPS	60	10772	SCREW MCH 6-32X 0.75 PHPH
7	70630	SCREW MCH 10-24x0.375 PHPH	61	10716	CON CABLE GLAND PG-16
8	70350	SCREW SET 3/8-16x1.250	62	10664	DECAL MADE IN USA
9	70268	DECAL HIX I.D. 3" X 3" SILVER	63	10259	SCREW MCH 1/4-20X.500 THPH SS
10	68098	GROMMET .625IDx.875 GRVx.125	64	10020	SCREW MCH 10-24X0.250 THPH SS
11	65936	SCREW SET 5/16-18x1.500 ZP			
12	59886	SCREW TAP 10-32x0.500 WHHX			
13	47753	NUT 3/8-16 JAM			
14	33605	DECAL, UNPLUG MACHINE			
15	30910	WASHER LOCK HEL SPR 5/16 ZP			
16	26042	WASHER FLT .406x0.875x.050 SS			
17	24732	WASHER FLT .344X0.688X.063 ZPS			
18	16386	TERM 12-10 RING 10 NON F			
19	1180194	SPACER, GREASE TRAY			
20	1180193	SPACER, .824ID X .922OD X .46 STEEL			
21	1180192	COVER, SHAFT SUPPORT			
22	1180191	ASSEMBLY, FAN AXIAL 50MM X 50MM 5VDC			
23	1180185	INSULATION, CONTROL PANEL SPLIT LID			
24	1180184	INSULATION, LOWER PLATEN 2 SPLIT LID			
25	1180181	BRACKET, INSULATION SUPPORT 1			
26*	1180176	SPLIT LID GRILL PACKAGING			
27	1180108	ASSEMBLY, BURN GUARD			
28	1180098	BRACKET CORD GRIP PG-16			
29	1180096	DOWEL PIN UPPER PLATEN REAR .375 SS			
30	1180095	DOWEL PIN UPPER PLATEN FRONT .375 SS			
31	1180088	ASSEMBLY, PLATEN UPPER LEFT PANINI 120V			
32	1180087	ASSEMBLY, PLATEN UPPER RIGHT PANINI			
33	1180082	WASHER, 0.344 ID X 0.625 OD X 0.62			
34	1180070	ASSEMBLY, CONTROL PANEL			
35	1180064	COVER REAR			
36	1180061	LINK ARM			
37	1180060	ELECTRICAL MTG TRAY			
38	1180058	ASSEMBLY, GREASE TRAY			
39	1180039	ASSEMBLY, LOWER PLATEN PANINI 120V			
40	1180035	SPACER 0.344ID X 0.625 OD X 0.468 AL			
41	1180024	ASSEMBLY, PLUNGER			
42	1180021	BRACKET, HEAT SHIELD FRONT			
43	1180019	COLLAR ADJ SPRING			
44	1180018	ASSEMBLY, COLLAR PLUNGER RIGHT			
45	1180012	ASSEMBLY, COLLAR PLUNGER LEFT			
46	1180011	SPACER SPRING			
47	1180001	ASSEMBLY, HOUSING 2			
48*	11251	WASHER FLT 0.938 X 1.75X 0.108 - 0.160 ZPS			
49	11250	SCREW MACHINE 10-24 X .500 PHPH SS			
50*	11198	WIRE KIT, SPLIT LID GRILL 120V			
51*	11197	MANUAL SPLIT LID GRILL			
52	11175	RETAINING RING EXT 0.375 E SS			
53	11148	CORDSET 120V 12/3 SOOW 5-30P			
54	11147	EDGE TRIM .375 X .275 X .150 SILICONE			



# REPLACEMENT PARTS LIST

## (DXP-CS-1577 MODEL)

ITEM#	PART#	TITLE	ITEM#	PART#	TITLE
1	986242	RETAINING RING EXT 0.750 E SS	55	11146	TORSION SPRING RIGHT SIDE
2	87619	NUT 5/16-18 JAM	56	11145	TORSION SPRING LEFT SIDE
3	86702	SCREW CPSKT 3/8-16x0.875	57	11141	SPRING, COMPRESSION DIE 0.500 X 0.28125
4	79426	WASHER LOCK HEL SPR 1/4 ZP	58	11140	SCREW SET 5/16-18 X .375
5	74674	TERM 18-14 RING 10 NON M	59	10963	DECAL, QR CODE DXP
6	70861	NUT 6-32 NYLON INSERT ZPS	60	10772	SCREW MCH 6-32X 0.75 PHPH
7	70630	SCREW MCH 10-24x0.375 PHPH	61	10716	CON CABLE GLAND PG-16
8	70350	SCREW SET 3/8-16x1.250	62	10664	DECAL MADE IN USA
9	70268	DECAL HIX I.D. 3" X 3" SILVER	63	10259	SCREW MCH 1/4-20X.500 THPH SS
10	68098	GROMMET .625IDx.875 GRVx.125	64	10020	SCREW MCH 10-24X0.250 THPH SS
11	65936	SCREW SET 5/16-18x1.500 ZP			
12	59886	SCREW TAP 10-32x0.500 WHHX			
13	47753	NUT 3/8-16 JAM			
14	33605	DECAL, UNPLUG MACHINE			
15	30910	WASHER LOCK HEL SPR 5/16 ZP			
16	26042	WASHER FLT .406x0.875x.050 SS			
17	24732	WASHER FLT .344X0.688X.063 ZPS			
18	16386	TERM 12-10 RING 10 NON F			
19	1180194	SPACER, GREASE TRAY			
20	1180193	SPACER, .824ID X .922OD X .46 STEEL			
21	1180192	COVER, SHAFT SUPPORT			
22	1180191	ASSEMBLY, FAN AXIAL 50MM X 50MM 5VDC			
23	1180185	INSULATION, CONTROL PANEL SPLIT LID			
24	1180184	INSULATION, LOWER PLATEN 2 SPLIT LID			
25	1180181	BRACKET, INSULATION SUPPORT 1			
26*	1180176	SPLIT LID GRILL PACKAGING			
27	1180137	ASSEMBLY, PLATEN UPPER LEFT FLAT 120V			
28	1180134	ASSEMBLY, PLATEN UPPER RIGHT FLAT 120V			
29	1180132	ASSEMBLY, LOWER PLATEN FLAT 120V			
30	1180108	ASSEMBLY, BURN GUARD			
31	1180098	BRACKET CORD GRIP PG-16			
32	1180096	DOWEL PIN UPPER PLATEN REAR .375 SS			
33	1180095	DOWEL PIN UPPER PLATEN FRONT .375 SS			
34	1180082	WASHER, 0.344 ID X 0.625 OD X 0.62			
35	1180070	ASSEMBLY, CONTROL PANEL			
36	1180064	COVER REAR			
37	1180061	LINK ARM			
38	1180060	ELECTRICAL MTG TRAY			
39	1180058	ASSEMBLY, GREASE TRAY			
40	1180035	SPACER 0.344ID X 0.625 OD X 0.468 AL			
41	1180024	ASSEMBLY, PLUNGER			
42	1180021	BRACKET, HEAT SHIELD FRONT			
43	1180019	COLLAR ADJ SPRING			
44	1180018	ASSEMBLY, COLLAR PLUNGER RIGHT			
45	1180012	ASSEMBLY, COLLAR PLUNGER LEFT			
46	1180011	SPACER SPRING			
47	1180001	ASSEMBLY, HOUSING 2			
48*	11251	WASHER FLT 0.938 X 1.75X 0.108 - 0.160 ZPS			
49	11250	SCREW MACHINE 10-24 X .500 PHPH SS			
50*	11198	WIRE KIT, SPLIT LID GRILL 120V			
51*	11197	MANUAL SPLIT LID GRILL			
52	11175	RETAINING RING EXT 0.375 E SS			
53	11148	CORDSET 120V 12/3 SOOW 5-30P			
54	11147	EDGE TRIM .375 X .275 X .150 SILICONE			

# REPLACEMENT PARTS LIST (DXP-PS-157 MODEL)

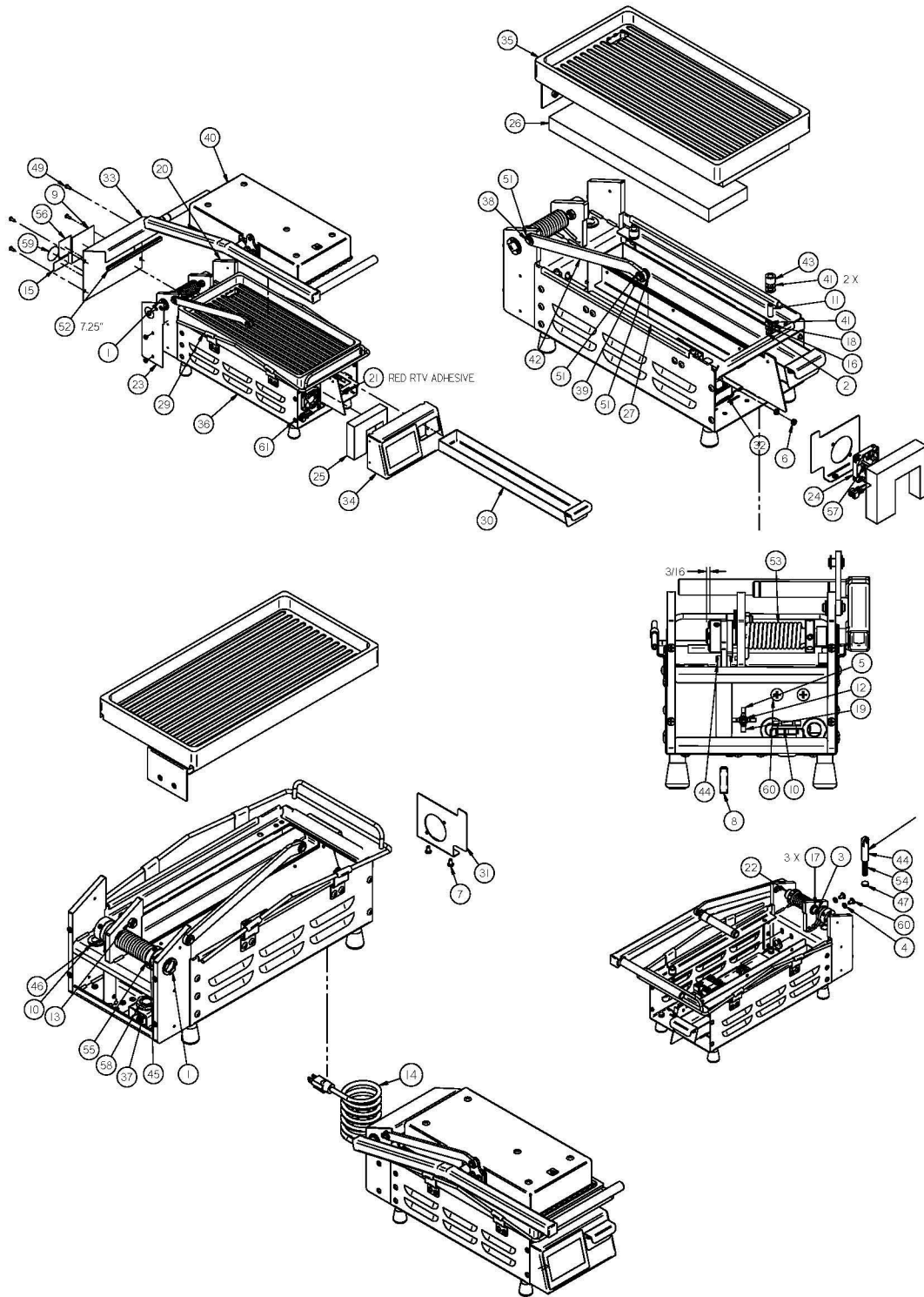

# REPLACEMENT PARTS LIST

## (DXP-PS-157 MODEL)

ITEM#	PART#	TITLE	ITEM#	PART#	TITLE
1	9862428	RETAINING RING EXT 0.750 E SS	55	11140	SCREW SET 5/16-18 X .375
2	87619	NUT 5/16-18 JAM	56	10963	DECAL, QR CODE DXP
3	86702	SCREW CPSKT 3/8-16x0.875	57	10772	SCREW MCH 6-32X 0.75 PHPH
4	79426	WASHER LOCK HEL SPR 1/4 ZP	58	10716	CON CABLE GLAND PG-16
5	74674	TERM 18-14 RING 10 NON M	59	10664	DECAL MADE IN USA
6	70861	NUT 6-32 NYLON INSERT ZPS	60	10259	SCREW MCH 1/4-20X.500 THPH SS
7	70630	SCREW MCH 10-24x0.375 PHPH	61	10020	SCREW MCH 10-24X0.250 THPH SS
8	70350	SCREW SET 3/8-16x1.250			
9	70268	DECAL HIX I.D. 3" X 3" SILVER			
10	68098	GROMMET .625IDx.875 GRVx.125			
11	65936	SCREW SET 5/16-18x1.500 ZP			
12	59886	SCREW TAP 10-32x0.500 WHHX			
13	47753	NUT 3/8-16 JAM			
14	39768	CORDSET 120v 14/3 STOW 5-15P			
15	33605	DECAL, UNPLUG MACHINE			
16	30910	WASHER LOCK HEL SPR 5/16 ZP			
17	26042	WASHER FLT .406x0.875x.050 SS			
18	24732	WASHER FLT .344X0.688X.063 ZPS			
19	16386	TERM 12-10 RING 10 NON F			
20	1180195	COVER, SHAFT SUPPORT RIGHT			
21	1180194	SPACER, GREASE TRAY			
22	1180193	SPACER, .824ID X .922OD X .46 STEEL			
23	1180192	COVER, SHAFT SUPPORT			
24	1180191	ASSEMBLY, FAN AXIAL 50MM X 50MM 5VDC			
25	1180187	INSULATION, CONTROL PANEL SINGLE LID			
26	1180186	INSULATION, LOWER PLATEN 2 SINGLE LID			
27	1180183	BRACKET, INSULATION SUPPORT 3			
28*	1180176	SPLIT LID GRILL PACKAGING			
29	1180172	ASSEMBLY, BURN GUARD 15X7			
30	1180169	ASSEMBLY, GREASE TRAY 15X7			
31	1180168	BRACKET, HEAT SHIELD FRONT 15X7			
32	1180165	ELECTRICAL MTG TRAY 15X7			
33	1180157	COVER REAR 15X7			
34	1180154	ASSEMBLY, CONTROL PANEL 15X7			
35	1180145	ASSEMBLY, LOWER PLATEN PANINI 120V 15X7			
36	1180139	ASSEMBLY, HOUSING 15X7			
37	1180098	BRACKET CORD GRIP PG-16			
38	1180096	DOWEL PIN UPPER PLATEN REAR .375 SS			
39	1180095	DOWEL PIN UPPER PLATEN FRONT .375 SS			
40	1180088	ASSEMBLY, PLATEN UPPER LEFT PANINI 120V			
41	1180082	WASHER, 0.344 ID X 0.625 OD X 0.62			
42	1180061	LINK ARM			
43	1180035	SPACER 0.344ID X 0.625 OD X 0.468 AL			
44	1180024	ASSEMBLY, PLUNGER			
45	1180019	COLLAR ADJ SPRING			
46	1180018	ASSEMBLY, COLLAR PLUNGER RIGHT			
47	1180011	SPACER SPRING			
48*	11263	WIRE KIT, SINGLE LID GRILL 120V			
49	11250	SCREW MACHINE 10-24 X .500 PHPH SS			
50*	11197	MANUAL SPLIT LID GRILL			
51	11175	RETAINING RING EXT 0.375 E SS			
52	11147	EDGE TRIM .375 X .275 X .150 SILICONE			
53	11145	TORSION SPRING LEFT SIDE			
54	11141	SPRING, COMPRESSION DIE 0.500 X 0.28125			

# REPLACEMENT PARTS LIST (DXP-CS-157 MODEL)

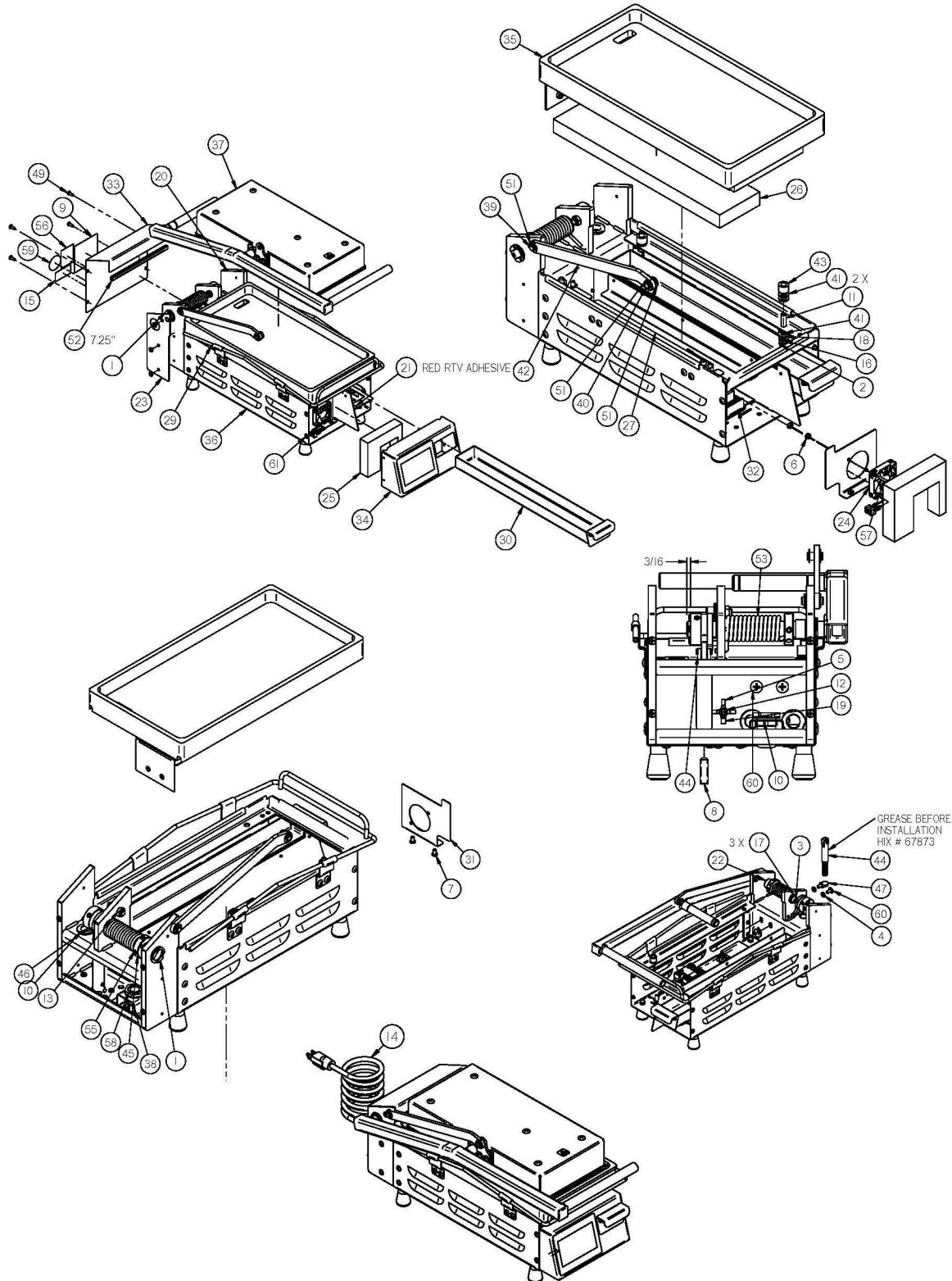

# REPLACEMENT PARTS LIST

## (DXP-CS-157 MODEL)

ITEM#	PART#	TITLE	ITEM#	PART#	TITLE
1	9862428	RETAINING RING EXT 0.750 E SS	55	11140	SCREW SET 5/16-18 X .375
2	87619	NUT 5/16-18 JAM	56	10963	DECAL, QR CODE DXP
3	86702	SCREW CPSKT 3/8-16x0.875	57	10772	SCREW MCH 6-32X 0.75 PHPH
4	79426	WASHER LOCK HEL SPR 1/4 ZP	58	10716	CON CABLE GLAND PG-16
5	74674	TERM 18-14 RING 10 NON M	59	10664	DECAL MADE IN USA
6	70861	NUT 6-32 NYLON INSERT ZPS	60	10259	SCREW MCH 1/4-20X.500 THPH SS
7	70630	SCREW MCH 10-24x0.375 PHPH	61	10020	SCREW MCH 10-24X0.250 THPH SS
8	70350	SCREW SET 3/8-16x1.250			
9	70268	DECAL HIX I.D. 3" X 3" SILVER			
10	68098	GROMMET .625IDx.875 GRVx.125			
11	65936	SCREW SET 5/16-18x1.500 ZP			
12*	59886	SCREW TAP 10-32x0.500 WHHX			
13	47753	NUT 3/8-16 JAM			
14	39768	CORDSET 120v 14/3 STOW 5-15P			
15*	33605	DECAL, UNPLUG MACHINE			
16	30910	WASHER LOCK HEL SPR 5/16 ZP			
17	26042	WASHER FLT .406x0.875x.050 SS			
18	24732	WASHER FLT .344X0.688X.063 ZPS			
19	16386	TERM 12-10 RING 10 NON F			
20	1180195	COVER, SHAFT SUPPORT RIGHT			
21	1180194	SPACER, GREASE TRAY			
22	1180193	SPACER, .824ID X .922OD X .46 STEEL			
23	1180192	COVER, SHAFT SUPPORT			
24	1180191	ASSEMBLY, FAN AXIAL 50MM X 50MM 5VDC			
25	1180187	INSULATION, CONTROL PANEL SINGLE LID			
26	1180186	INSULATION, LOWER PLATEN 2 SINGLE LID			
27	1180183	BRACKET, INSULATION SUPPORT 3			
28*	1180176	SPLIT LID GRILL PACKAGING			
29	1180172	ASSEMBLY, BURN GUARD 15X7			
30	1180169	ASSEMBLY, GREASE TRAY 15X7			
31	1180168	BRACKET, HEAT SHIELD FRONT 15X7			
32	1180165	ELECTRICAL MTG TRAY 15X7			
33	1180157	COVER REAR 15X7			
34	1180154	ASSEMBLY, CONTROL PANEL 15X7			
35	1180147	ASSEMBLY, LOWER PLATEN FLAT 120V 15X7			
36	1180139	ASSEMBLY, HOUSING 15X7			
37	1180137	ASSEMBLY, PLATEN UPPER LEFT FLAT 120V			
38	1180098	BRACKET CORD GRIP PG-16			
39	1180096	DOWEL PIN UPPER PLATEN REAR .375 SS			
40	1180095	DOWEL PIN UPPER PLATEN FRONT .375 SS			
41	1180082	WASHER, 0.344 ID X 0.625 OD X 0.62			
42	1180061	LINK ARM			
43	1180035	SPACER 0.344ID X 0.625 OD X 0.468 AL			
44	1180024	ASSEMBLY, PLUNGER			
45	1180019	COLLAR ADJ SPRING			
46	1180018	ASSEMBLY, COLLAR PLUNGER RIGHT			
47	1180011	SPACER SPRING			
48	11263	WIRE KIT, SINGLE LID GRILL 120V			
49	11250	SCREW MACHINE 10-24 X .500 PHPH SS			
50	11197	MANUAL SPLIT LID GRILL			
51	11175	RETAINING RING EXT 0.375 E SS			
52	11147	EDGE TRIM .375 X .275 X .150 SILICONE			
53	11145	TORSION SPRING LEFT SIDE			
54	11141	SPRING, COMPRESSION DIE 0.500 X 0.28125			

# WARRANTY

**BEFORE warranty repair you MUST get Prior Authorization: Call 1-800-835-0606 Warranty will be voided otherwise.**

doughXpress® will automatically register the equipment on the date it was shipped to you or your distributor. If the equipment was not purchased directly from HIX, but through a distributor (either domestic or foreign), please keep a copy of their sales invoice showing the serial number and date it was sold/shipped to you with this warranty.

In this case, we will use the distributor's invoice date as the beginning warranty date. **STAPLE A COPY OF YOUR RECEIPT TO THIS WARRANTY** and keep in a safe place to provide verification of your warranty should a problem occur. Thank you.

Please fill in the following information and attach a copy of your receipt for your records.

**Date Purchased:** \_\_\_\_\_ **From:** \_\_\_\_\_  
**Model #:** \_\_\_\_\_ **Serial #:** \_\_\_\_\_

This warranty applies to equipment manufactured by the HIX Corporation (HIX), Pittsburg, Kansas, U.S.A. HIX warrants to the original purchaser, the full line of doughXpress® product against defects in workmanship and material, except for wear and tear for a period of one year parts and labor limited warranty on most items, there are selected items which may carry a two year warranty (refer to owners manual.) All dough press carts, compressors, and accessories are warranted for 90 days from the date of purchase. Repairs include parts and labor only, excluding is the following:

1. Overtime Labor Rates
2. Expedited Freight for Parts
3. doughXpress® assumes no responsibility for down time or loss of product. All defective parts must be returned to doughXpress® for credit. Repairs must be pre-authorized by doughXpress® prior to work commencing.
4. Travel time is not covered by doughXpress®, unless pre-authorized by doughXpress®. In the event of a defect, doughXpress®, at its option, will repair, replace or substitute the defective item at no cost during this period subject to the limitations of insurance and shipping costs stated below.

This warranty does not cover normal wear and tear, damages due to accident, misuse/abuse, alterations or damage due to neglect, or lack of proper lubrication or maintenance. doughXpress® shall not be responsible for repairs or alterations made by any person without the prior written authorization by doughXpress®. This warranty is the sole and exclusive warranty of doughXpress® and no person, agent, distributor, or dealer of doughXpress® is authorized to change, amend or modify the terms set forth herein, in whole or in part.

In the case of a problem with the equipment identified herein, doughXpress® should be contacted during regular business hours to discuss the problem and verify an existing warranty. doughXpress® personnel will assist the customer to correct any problems which can be corrected through operation or maintenance instructions, simple mechanical adjustments, or replacement of parts. In the event the problem cannot be corrected by phone, and upon the issuance of a return authorization by doughXpress®, the equipment shall be returned to doughXpress® or an authorized service representative. All insurance, packaging and shipment/freight costs are solely the responsibility of the customer, and doughXpress® shall not be responsible for improper handling or damage in transit.

doughXpress® customer service personnel may be contacted for complete return authorization and reconditioning information. This expressed warranty is given in lieu of any and all other warranties, whether expressed or implied, including but not limited to those of merchantability and fitness for a particular purpose, and constitutes the only warranty made by doughXpress®. In no event shall doughXpress®' liability for breach of warranty extend beyond the obligation to repair or replace the nonconforming goods. doughXpress® shall not be liable for any other damages, either incidental or consequential, or the action as brought in contract, negligence or otherwise.

This warranty gives you specific legal rights and you may also have other rights which vary from state to state.



1201 E. 27th Terrace • Pittsburg, KS 66762 • U.S.A.

Phone: (800) 835-0606 • Fax: 620-231-1598

Web site: [hixcorp.com](http://hixcorp.com) • E-Mail: [sales@hixcorp.com](mailto:sales@hixcorp.com)