

OPERATOR'S MANUAL

DXSM-270

Bun & Bagel Slicer

 **DOUGH
XPRESS**
HIX® CORPORATION COMMERCIAL FOOD DIVISION



For Customer Service:
Call **1-800-835-0606** or Visit **hixcorp.com**

HIX
CORPORATION



CONTENTS

- Safety Information*3-5
- Receiving & Setup* 6
- Introduction* 7
- Operation*8-9
- Cleaning & Maintenance*.....10-12
- Troubleshooting* 13
- Electrical*..... 14
- Assembly* 15
- Replacement Parts* 16
- Maintenance Record*..... 17
- Warranty*..... 19

BEFORE warranty repair you MUST get Prior Authorization



DoughXpress DXSM-270 BUN & BAGEL SLICER

Operator Instructions and Safety Information

All employees operating, servicing and cleaning this machine must be properly trained as to its operation and safety features.

Read and understand all instructions and safety practices before attempting operation! Pay particular attention to Warning and Caution messages indicating personal safety instructions. Failure to comply with safety instructions may result in serious personal injury.

WARNING: The slicing Blade is sharp and dangerous. Keep hands out of the cutting area. A severe cutting or abrasion injury could result. Do not operate this machine without guards in place.

WARNING: The slicing Blade is sharp and dangerous. Never attempt to clear a product jam with your hands. A severe cutting or abrasion injury could result. To clear a product jam, turn the machine "OFF", disconnect the power supply, wait for the Blade to stop rotating, and clear the Chute using a flat instrument.

NOTE: Product can be removed easier by increasing the Blade cutting height by turning the Large Black Knob [3] clockwise.

WARNING: The Blade on the Model 270 Slicer will coast to a stop after the power is switched to "OFF". To prevent personal injury or possible damage to the Slicer components, wait for the blade to stop completely before making any adjustments. To lessen the coast time, apply pressure to the Blade Brake located above the On/Off Switch.

IMPORTANT: It is imperative that the Slicer Blade is kept sharp and that the machine is cleaned frequently. Slicing dense products or those with additives such as raisins, nuts, or dried fruit chips may cause premature unit wear or even failure if:

- 1) The Blade is not kept sharp.
- 2) The Slicer is not cleaned frequently.
- 3) The rate at which the product is fed into the Slicer is too great.

IMPORTANT: Safety and instructional labels are easily visible to the operator and are located near any area of potential danger. Replace any decal that becomes damaged or worn.

WARNING: TURN THE MACHINE OFF AND DISCONNECT THE POWER SUPPLY BEFORE PERFORMING ANY TYPE OF SERVICING, CLEANING, MAINTENANCE OR INSPECTIONS.

The General Safety Practices listed on the following pages are recommended precautions and not related to any specific procedures. Operators should understand and apply these safety precautions during all phases of operation and maintenance.

GENERAL SAFETY PRACTICES

You will ensure safe working conditions for yourself and fellow employees by observing the following general safety guidelines. Please take the time to study them carefully and review them periodically.

Treat this equipment with the respect its power and speed demand.

- This machine was designed to run only when all safety devices and guards are in place. It should never be operated if any guards or access panels have been removed.
- Warnings displayed on machinery were put there to inform and remind people of unsafe practices. They are not to be altered or removed. Replace torn or worn labels immediately.
- Keep fingers, hands or any part of the body out of the machine and away from moving parts.
- Never bypass limit or other safety switches.
- “Horseplay” around machinery at any time is dangerous and should not be tolerated.
- Never sit or stand on anything that might cause you to fall against the machine.

DRESS THE PART.

- Make sure that nothing you are wearing could get caught in the machinery. This means no loose clothing or apron strings and no jewelry, ties, watch chains, unrestrained long hair, etc. near operating machinery.

Correct operation equals Safe operation.

- BEFORE operating this equipment, read the operating instructions and become thoroughly familiar with the machine and its controls.
- Know how to turn the machine off.
- Use the equipment only for its intended purpose.
- Make sure the electrical power is turned off when the machine is not in use.
- Disconnect the power supply before performing any type of servicing, maintenance, or cleaning or dislodging jammed product.
- If the machine is being serviced, the power source should be LOCKED OUT and the plug disconnected. This will prevent anyone from accidentally turning on power to the machine.
- Anything with moving parts requires periodic maintenance. Failure to practice good maintenance can lead to unsafe conditions. If you suspect faulty or damaged equipment, remove it from service and have it repaired by authorized personnel.

GENERAL SAFETY PRACTICES

Provide a safe, clean environment for yourself and others

- Remove any tools or other foreign objects from the operating zone before starting. Do not lay any items (coffee cup, scraper, knife, etc.) on the equipment or near the operating areas.
- Keep the operating zone free of obstacles that could cause a person to trip or fall toward an operating machine..

Stay Alert

- Any machine with moving parts and electrical components can be potentially dangerous, no matter how many safety features it has. It is essential that you make every effort to stay alert and think clearly around heavy machinery. Anyone fatigued, emotionally upset or under the influence of drugs or alcohol is primed for an accident.
- Be attentive to indicator lights and warnings displayed on the machine and know how to respond.
- Know where your FIRST AID SAFETY STATION is located in case of an emergency.

Safety Labels

The Safety Label shown below must always be on your machine. An explanation of each label is included. Inspect the machine periodically to be certain these warning labels are in place. If any label is removed or becomes unreadable, replace it immediately. Order replacement labels from doughXpress®, using the part numbers shown.

Definitions

DANGER - An immediate hazard with a possibility of severe personal injury or death if instructions, including recommended precautions, are not followed.

WARNING - Hazards or unsafe practices which could result in severe personal injury or death if instructions, including recommended precautions, are not followed.

Possible hazards or unsafe practices which could result in minor or moderate injury or damage to product or property if instructions, including recommended precautions, are not followed.

Safety Label used on machine



Replacement Part Number - 50217

RECEIVING & SETUP

Rotating cutters are SHARP and DANGEROUS in both the idle and running modes. KEEP HANDS OUT OF THE CUTTING AREA. A SEVERE INJURY COULD RESULT. All guards should remain on the machine for the safety of the operators. DO NOT operate machine without guards.

ALWAYS lockout main power disconnect before attempting to clean, service, perform maintenance or repair. Accidental start-up could result in a serious injury. Safety and instructional decals, as applied by the manufacturer, are easily visible to the operator and are located near any area of potential danger. Inspect the machine periodically to be certain all warning labels are in place. In the interest of operator safety, replace any decal that is damaged or lost.

UNCRATING INSTRUCTIONS

For the DoughXpress MODEL DXSM-270 BUN & BAGEL SLICER

CAUTION: KEEP THE CARTON UPRIGHT AT ALL TIMES

1. Model 270: Remove the metal staples and remove the cardboard covering from the skid.
2. Unbolt the machine from the skid or plywood depending on model. Bolts are accessed from the bottom of the skid or plywood to the machines base.
3. Lift Slicer by grasping by the bottom of the Base and place it on the location where it will be used - on a counter, sturdy table or other suitable flat surface.
4. Remove the instruction booklet from the Chute.
5. Make sure the switch is in the "OFF" position.
6. Make sure the chute is clear of obstructions.
7. Plug the cord into the proper voltage outlet.
8. To insure proper operation of the machine, it must be placed on a solid surface and have the feet leveled for stability.

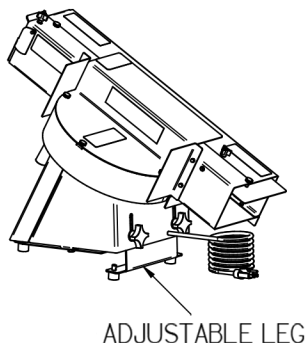

Incline Adjustment

Loosen both knobs, adjust leg height, ensure it's level side-to-side, then retighten knobs securely.

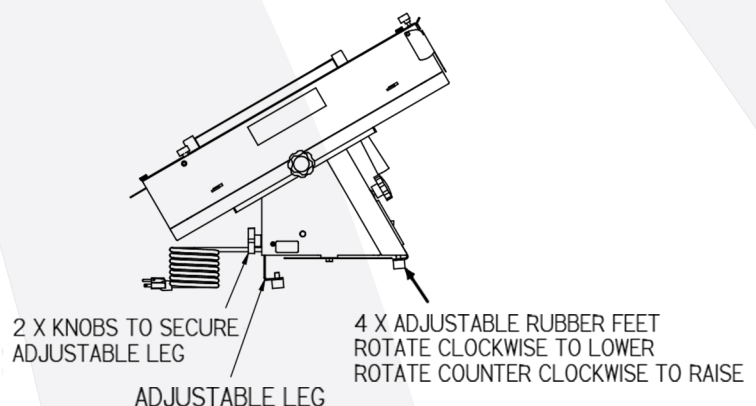

Leveling

Adjustable rubber feet at each corner compensate for uneven surfaces—turn clockwise to lower, counterclockwise to raise.

6 **NOTE:** Do not lift or carry the Model DXSM-270 or Bun & Bagel Slicers by the infeed and discharge ends of the Chute. Lifting or carrying the machine in such a manner can cause damage to the Chute or adjusting mechanism inside the base. Lift by holding and supporting the bottom of Base Frame only.

INTRODUCTION

Many hours of engineering design and performance testing have gone into your DoughXpress Model DXSM-270(C) Bun & Bagel Slicer. With proper care and maintenance this machine will give you efficient performance and convenient operation throughout its long life.

Safety and reliability are engineered into all DoughXpress equipment. We urge machinery operators to study the safety section of this manual and to learn how to operate and maintain the equipment correctly.

This manual has been made for your convenience and instruction. Keep this book on file and always include Model Number and Serial Number of the machine when ordering parts.

Read and understand all instructions and safety practices before attempting operation! Pay particular attention to Warning and Caution messages indicating personal safety instructions. Failure to comply with safety instructions may result in personal injury.

ELECTRICAL CONNECTION

Electrical specifications for your machine are printed on the Serial Number tag which is located near the electrical power cord point of exit on the machine. Be sure to check your plant voltage with the voltage specified on the machine.

(Refer to page __ for additional electrical information)

A properly grounded receptacle is required for safe operation regardless of the voltage requirements.

CUSTOMER SERVICE

If you encounter a problem with your DoughXpress Model 270 Bun & Bagel Slicer, refer to the Cleaning & Maintenance, or the Troubleshooting sections of this manual. If you cannot quickly resume normal operation, contact DoughXpress Customer Service (800) 835-0606 x 205.

You must have Model and Serial Number of unit Before Calling!

WARNING

TURN THE MACHINE OFF AND DISCONNECT THE POWER SUPPLY BEFORE PERFORMING ANY TYPE OF SERVICING, CLEANING, MAINTENANCE OR INSPECTIONS.

WARNING

The Blade on the Model DXSM-270 Slicer will coast to a stop after the power is switched off. To prevent personal injury or possible damage to the Slicer components, **wait for the Blade to stop completely before making any adjustments.**

OPERATION

OPERATION:

1. Turn on the power switch
2. Place a bun in the top of the chute and drop it down the chute.
3. The sliced bun will exit at the bottom of the chute.
4. Make any cutting adjustments as necessary by following the steps below.
5. If a bun becomes lodged in the chute, turn the machine off, allow the blade to stop rotating and unplug from power before removing the lodged bun

ADJUSTABLE SETTINGS

1. To adjust for the input height of the product, turn the Small Black Knob (6) up or down to raise or lower the Input Flap adjustment and increase or decrease the height of the Flap.
NOTE: For small product requiring “gravity” feed, adjust the Flap high enough to allow free flow of product down Chute without making direct contact with the Flap.
2. To adjust for discharge rate of product, raise or lower the Output Flap. by turning the Small Black Knob (6) up or down depending on the desired result.
3. To adjust for the width of the product slide the Hinge Guide (8) to desired width using the inscribed markings to set an equal width at the upper and lower ends of the Chute. The width setting must allow the product to pass through the machine freely.
4. To adjust for the thickness of the cut, turn Large Black Knob (3) clockwise to lower (thicker cut) or counterclockwise to raise (thinner cut) the bottom of the Chute from the Blade.
5. To adjust for the depth of the cut, turn Large Black Knob (4) to desired depth (less for a hinge on buns; more for a complete cut).
NOTE: For a complete through cut, the tip of the Blade must go into the rectangular opening in the Hinge Guide (8).
6. To adjust for Chute Angle, loosen both Large Black Knobs (5) and raise and lower the Base by lifting to desired angle, and retighten both Large Black Knobs. (Be sure to support the Base while making this adjustment. The machine’s Base will automatically lower when Large Black Knobs are loosened.)
NOTE: A steeper angle is required for smaller products such as buns and bagels to allow for better “gravity” feed. A lesser angle will allow for French Bread to easily exit the Chute onto the work bench.
NOTE: Adjustments should be liberal to allow for irregular baking uniformity.
7. To stop the blade after the machine has been turned off, rotate the blade stop handle (2).

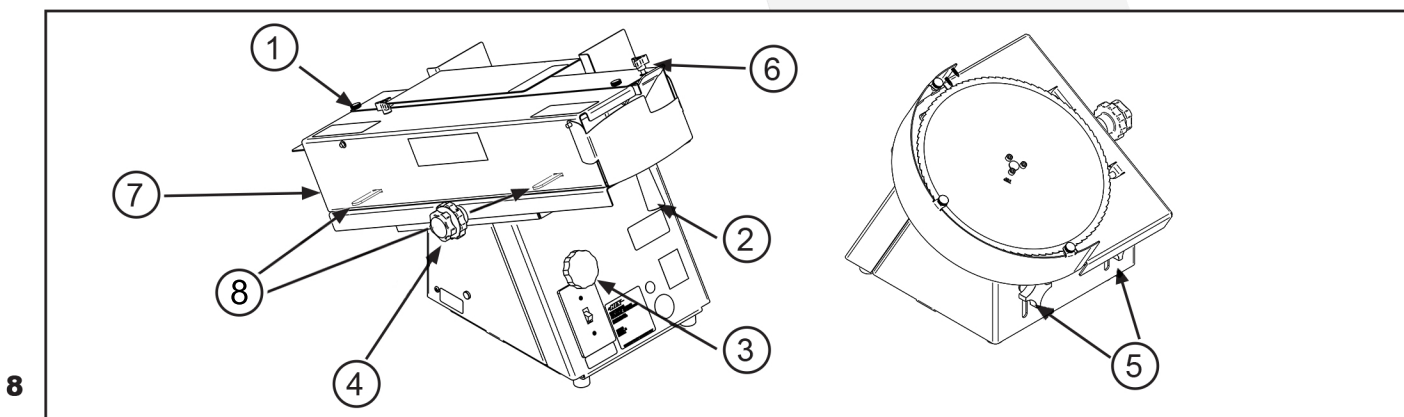

Figure 8-1

TIPS FOR SLICING BUNS (WITH MAXIMUM CHUTE ANGLE)

Step One:

Adjust Chute opening for the product width using the Hinge Guide [Item 8, Figure 8-1] so the product has sufficient clearance to slide freely through the Chute. It is recommended you set the Chute width approximately 1/4" - 3/8" inch wider than the product to be sliced. Note: It may be necessary to test this by holding the product into the Chute opening, with the POWER TURNED OFF, to visually identify the proper amount of clearance is set.

Step Two:

Adjust for the Depth of Cut (Hinged Cut or Complete through Cut) by turning the Knob [Item 4, Figure 8-1] Clockwise to increase the Depth for a complete through cut, and counter-clockwise for a hinged cut.

Note: You may need to visually view into the Chute from the Input end of the Chute to determine the desired position of the Blade to the Hinge Guide.

- For a Complete Through Cut, the Blade should extend into the opening in the Hinge Guide approximately 1/4 inch or more.
- For a Hinged Cut, the Blade should be kept away from the Hinge Guide approximately 1/4 - 1/2 inch to achieve your desired results.

Step Three

Adjust for Thickness of Cut (from the bottom of product) by turning the Knob [Item 3, Figure 8-1] clockwise for a thicker cut, and counterclockwise for a thinner cut.

Step Four

Adjust the Output Flap by turning the Black Knob clockwise to speed up the discharge rate of the product, or turn the Knob counterclockwise to slow the discharge rate of product.

TIPS FOR FRENCH BREAD (WITH MAXIMUM CHUTE ANGLE)

Follow steps 1-4 above and add the following:

Step Five:

Adjust the Input Flap (Model M-270 only) downward by turning the Black Knob clockwise to increase the space between the Input Flap and the bottom of the Chute, and counterclockwise to lessen the space. Note: The closer the Input Flap is to the bottom of the Chute, the more effective it is at holding the loaf down which creates a more uniform cut.

Step Six:

Model 270: Reduce the Angle of the Chute by loosening the two Black Knobs and lifting the discharge end of the BASE which will allow the adjustable legs to lower. While holding/supporting the Base end up, retighten the two Black Knobs.

Note: Be sure the power is turned OFF and the Blade has stopped before making any adjustments.

CLEANING & MAINTENANCE

GENERAL CLEANING

WARNING: Turn the machine off and disconnect the power supply before performing any type of servicing, cleaning, maintenance, or inspections.

The manufacturer recommends frequent cleaning, especially the removal of crumbs from around the Blade. Manufacturer recommends cleaning the slicing Blade and the Blade area with a damp cloth. Dry Blade and Blade area thoroughly.

IMPORTANT: Cutting products such as bagels that leave a sticky residue or products with additives such as raisins or dried fruit chips requires more frequent and thorough cleaning. The Blade should be scrubbed with a nylon brush.

CAUTION: Do not spray the unit with water; damage to the electrical components will occur.

PREVENTATIVE MAINTENANCE

The motor in the DXSM-270 has sealed bearings. No lubrication is required.

For optimal performance, the Slicer Blade should be re-sharpened after a period of use.

We recommend keeping a spare Blade available at all times.

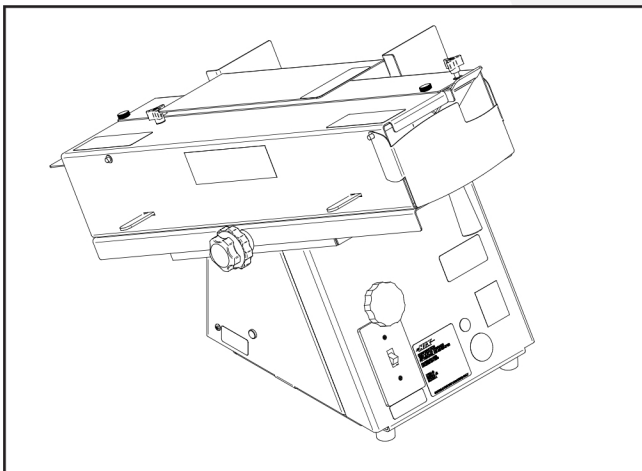

WARNING

TURN THE MACHINE OFF AND DISCONNECT THE POWER SUPPLY BEFORE PERFORMING ANY TYPE OF SERVICING, CLEANING, MAINTENANCE OR INSPECTIONS

WARNING

THE BLADE ON THE MODEL 270 SLICER WILL COAST TO A STOP AFTER THE POWER IS SWITCHED OFF. TO PREVENT PERSONAL INJURY OR POSSIBLE DAMAGE TO THE SLICER COMPONENTS, WAIT FOR THE BLADE TO STOP COMPLETELY BEFORE MAKING ANY ADJUSTMENTS.

CLEANING & MAINTENANCE

FOOD AREA CLEANING

The DXSM-270 features a removeable chute and blade for ease of cleaning. Use a mild soap and non abrasive wash cloth when cleaning the parts.

1. Unplug the machine
2. Chute removal
 - a. Hold the large knob with one hand and then loosen the smaller knob
 - b. Next, remove the larger inside knob
 - c. After both knobs are removed, note the position of the nylon washer and insure it is not lost
 - d. Finally, grasp the chute and slide free of the base
3. Clean the machine then reverse the process to reassemble.

a.



b.



c.



d.

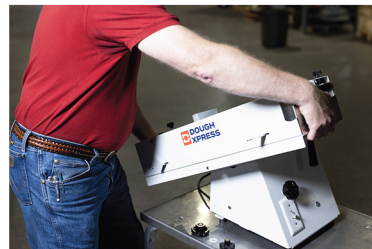

WARNING

TURN THE MACHINE OFF AND DISCONNECT THE POWER SUPPLY BEFORE PERFORMING ANY TYPE OF SERVICING, CLEANING, MAINTENANCE OR INSPECTIONS

THE BLADE ON THE MODEL 270 SLICER WILL COAST TO A STOP AFTER THE POWER IS SWITCHED OFF. TO PREVENT PERSONAL INJURY OR POSSIBLE DAMAGE TO THE SLICER COMPONENTS, WAIT FOR THE BLADE TO STOP COMPLETELY BEFORE MAKING ANY ADJUSTMENTS.

CLEANING & MAINTENANCE

ACCESSING BLADE AREA

Refer to Page 15, for parts location. TOOLS REQUIRED: 3/16 HEX WRENCH

Step 1. Remove the HOUSING TOP COVER [39] by removing the three (3) small black knobs [26].

Step 2. Remove the three (3) screws [11] with 3/16 HEX WRENCH securing the blade and carefully remove the blade.

Step 3. Replace the clean (or new) blade and tighten the three (3) screws [11] to secure the blade.

IMPORTANT: Make sure that the points on the teeth are pointing in the opposite direction of the rotation of the blade, which is clockwise when looking at the shaft end of the motor. The blade is engraved with "TOP" to insure proper installation.

Step 4. Replace the HOUSING TOP COVER [39], replace and tighten the three (3) small black knobs [26].

1.



2.



3.

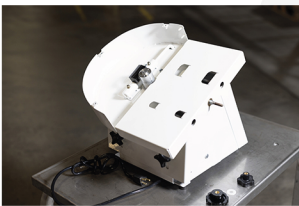

4.



TROUBLESHOOTING

WARNING

TURN THE MACHINE OFF AND DISCONNECT THE POWER SUPPLY BEFORE PERFORMING ANY TYPE OF SERVICING, CLEANING, MAINTENANCE OR INSPECTIONS.

Symptom	Probable Cause	Corrective Action
Motor does not start:	Power interruption	Check power supply Check ON/OFF switch Turn machine off for five minutes. Press switch down to reset, then up to turn machine back on.
	Excessive crumbs in Blade area	Clean crumbs from Blade area.
Slicer stops running:	Overload - from product jam	Turn the machine "OFF," disconnect power supply, clear chute using a flat instrument
	Overload - from dull blade	Sharpen or replace blade.
Product isn't cut clean	Product too warm	Cool product to room temperature before slicing.
	Hinge Guide and Input Flap set too close.	Adjust Hinge Guide and Input Flap so product has clean passage.
	Dull Blade	Sharpen and replace Blade

IMPORTANT: Due to the wide variety of finished product densities and additives (i.e. raisins, onions, dried fruit chips, etc.), it is imperative that the machine be cleaned frequently and the slicer blade be sharpened periodically. Slicing dense products or those with additives may cause premature unit wear or even failure if:

- 1) The blade is not kept sharp
- 2) The slicer is not frequently cleaned
- 3) The rate at which the product is fed into the slicer is too great.

DXSM-270 ELECTRICAL

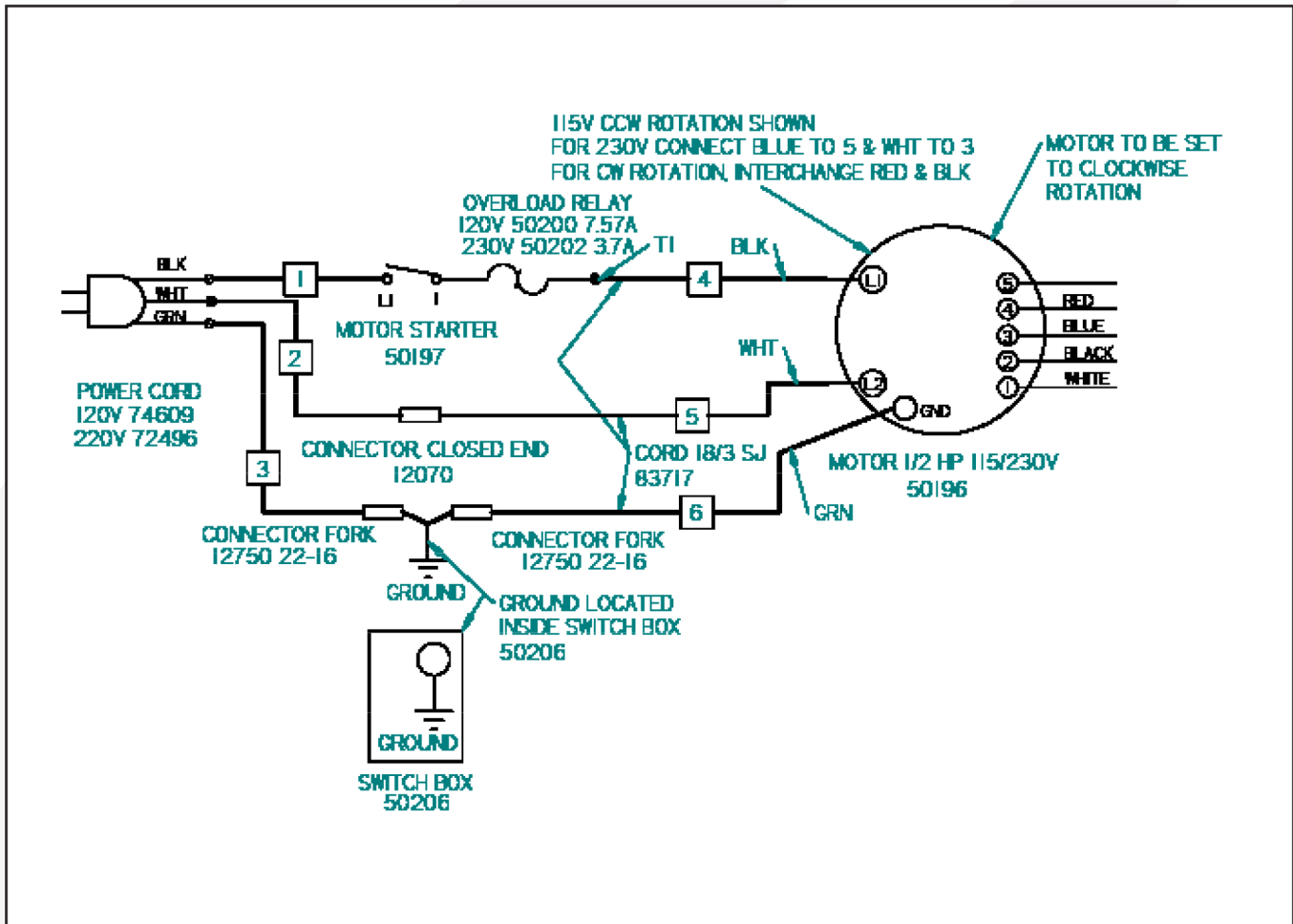

Electrical Schematic - DXSM-270

DXSM-270 ASSEMBLY

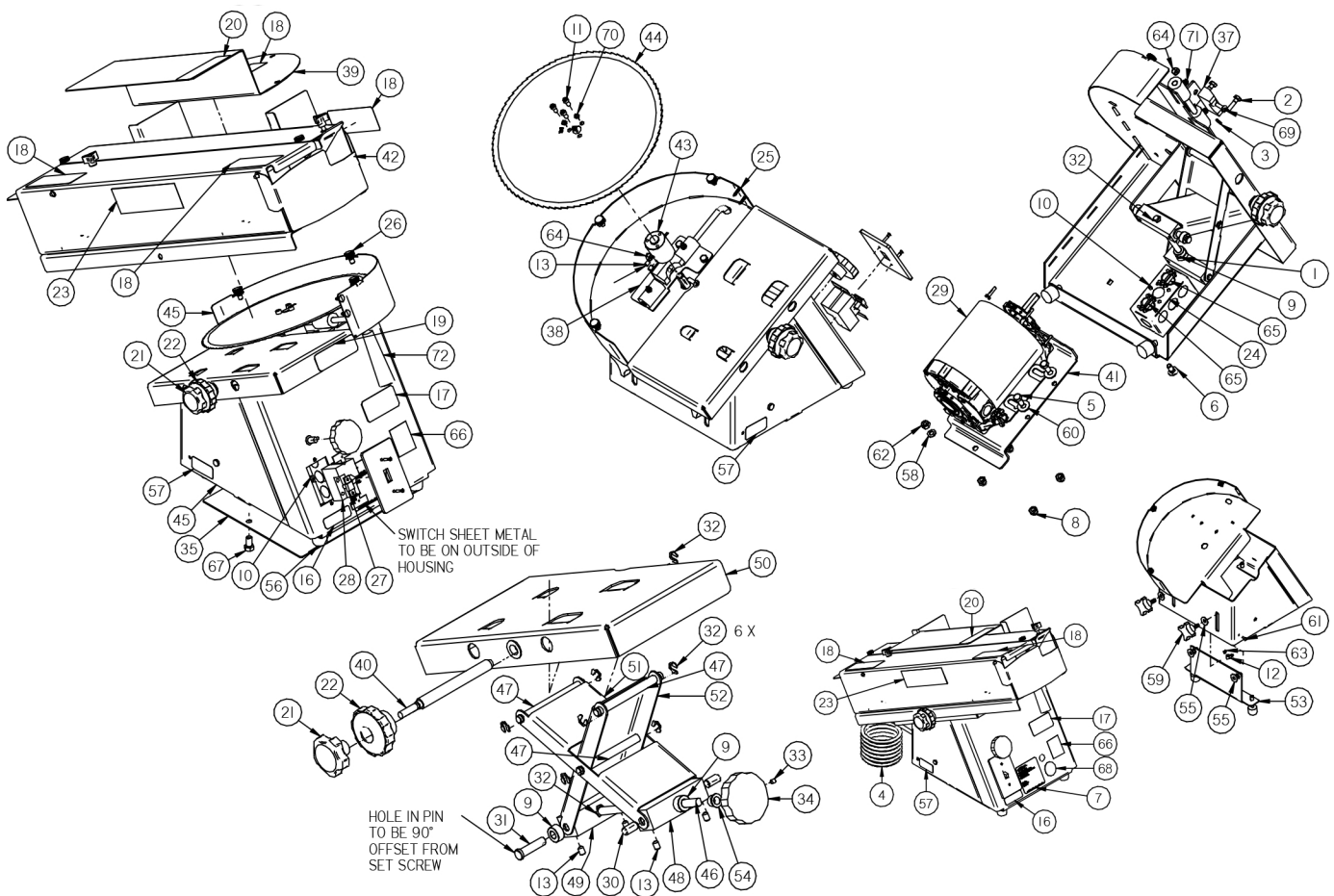

DXSM-270 REPLACEMENT PARTS

ITEM#	PART#	TITLE	ITEM#	PART#	TITLE
1	87056	NUT 1/2-13 JAM	51	5010058	LIFT BRACKET 2
2	84004	BOLT 1/4-20x1.000	52	5010057	LIFT BRACKET 1
3	79426	WASHER LOCK HEL SPR 1/4 ZP	53	5010056	FOOT, ADJUSTABLE
4	74609	CORDSET 120v 16/3 SJOW 5-15P	54	50043	BEARING .375 X .5 X .375 FLANGED NYLON WHITE
5	71498	BOLT 5/16-18x0.750 G8	55	50042	WASHER FLT .406 X 1.00 X .074 NYLON WHITE
6	71029	BOLT CAR 5/16-18x0.750	56	50041	FOOT RUBBER 1.00 X 0.75 BLACK 1/4-20X0.5 STUD
7	70268	DECAL HIX I.D. 3" X 3" SILVER	57	33605	DECAL, UNPLUG MACHINE
8	68594	NUT 5/16-18 NYLON INSERT ZPS	58	30910	WASHER LOCK HEL SPR 5/16 ZP
9	67334	COLLAR SET .375 ID X .75 OD X .375 W	59	19739	KNOB 3/8-16x1.0 STUD PLASTIC
10	66729	SCREW MCH 10-32x0.375 GRND	60	16683	WASHER FLT .375x0.875x.078 ZPS
11	65927	SCREW CPSKT 1/4-20x0.500 ZP	61	15339	SCREW MACHINE 10-24 X .500 PHPH
12	59765	STRAP LOOP NYLON 5/16	62	14605	NUT 5/16-18 ZPS
13	57096	SCREW SET 1/4-20x0.375	63	14563	NUT 10-24 ZPS
14*	50227	WIRE KIT DXSM-270 120V	64	14514	NUT 1/4-20 NYLON INSERT ZPS
15*	50226	MANUAL, DXSM-270	65	11940	CONNECTOR ROMEX 3/8"
16	50219	DECAL, RESET MOTOR STARTER	66	10963	DECAL, QR CODE DXP
17	50218	DECAL, BLADE BRAKE	67	10843	BOLT 3/8-16X0.750
18	50217	DECAL, SHARP BLADE	68	10664	DECAL MADE IN USA
19	50216	DECAL, CUT HEIGHT	69	10661	SCREW MCH 1/4-20 X .750 PHP
20	50214	DECAL, CUT DEPTH	70	10518	WASHER LOCK HEL SPR 1/4 SH BO
21	50210	KNOB, 5 LOBE 5/16-18 FEMALE	71	10357	DETENT BALL 3/8-16x0.188 PLUNGER / LOCK
22	50209	KNOB, 8 LOBE 5/16-18 THROUGH	72	10032	HANDLE 3.875" TAPERED PHENOLIC
23	50207	DECAL DXSM-270			
24	50206	BOX ELECT 4 X 2-1/8 X 2-1/8 DP			
25	50205	RIVET PUSH IN DOMED 7/16 O.D.			
26	50203	SCREW THUMB 10-24 X 3/8 BLACK			
27	50200	RELAY, THERMAL OVERLOAD 7.57A			
28	50197	STARTER, MOTOR 16A, NO			
29	50196	ENCLOSURE			
30	50168	MOTOR, CENTURY 1/2 HP 115-230V			
31	50167	PIN DOWEL 0.375 X .75 STL			
32	50160	PIN CLEVIS 0.375 X 1.5 STL ZP			
33	50158	RETAINING RING EXT 0.313 E SPRING			
34	50157	STEEL			
35	5010095	SCREW SET 10-32X0.250 CP ZP			
36*	5010094	KNOB, PHENOLIC 8 LOBE BLACK			
37	5010092	COVER, ACCESS BOTTOM			
38	5010089	DXSM-270 PACKAGING			
39	5010077	SHOE BLADE BRAKE			
40	5010076	WELDMENT BRAKE LEVER			
41	5010075	COVER, HOUSING TOP			
42	5010073	ROD CHUTE ADJUSTMENT			
43	5010069	BRACKET, MOTOR MOUNT			
44	5010068	ASSEMBLY, LONG CHUTE			
45	5010067	BLADE ADAPTER			
46	5010063	BLADE 12.5 INCH X .062 5/8" BORE			
47	5010062	WELDMENT, BASE			
48	5010061	ROD, LIFT MAIN			
49	5010060	PIN 0.375 X 4.125 GOOVED STL			
50	5010059	LIFT, HINGE			

MAINTENANCE RECORD

NOTES

WARRANTY

BEFORE warranty repair you MUST get Prior Authorization: Call 1-800-835-0606 Warranty will be voided otherwise.

doughXpress® will automatically register the equipment on the date it was shipped to you or your distributor. If the equipment was not purchased directly from HIX, but through a distributor (either domestic or foreign), please keep a copy of their sales invoice showing the serial number and date it was sold/shipped to you with this warranty.

In this case, we will use the distributor's invoice date as the beginning warranty date. **STAPLE A COPY OF YOUR RECEIPT TO THIS WARRANTY** and keep in a safe place to provide verification of your warranty should a problem occur. Thank you.

Please fill in the following information and attach a copy of your receipt for your records.

Date Purchased: _____ **From:** _____

Model #: _____ **Serial #:** _____

This warranty applies to equipment manufactured by the HIX Corporation (HIX), Pittsburg, Kansas, U.S.A. HIX warrants to the original purchaser, the full line of doughXpress® product against defects in workmanship and material, except for wear and tear for a period of one year parts and labor limited warranty on most items, there are selected items which may carry a two year warranty (refer to owners manual.) All dough press carts, compressors, and accessories are warranted for 90 days from the date of purchase. Repairs include parts and labor only, excluding is the following:

1. Overtime Labor Rates
2. Expedited Freight for Parts
3. doughXpress® assumes no responsibility for down time or loss of product. All defective parts must be returned to doughXpress® for credit. Repairs must be pre-authorized by doughXpress® prior to work commencing.
4. Travel time is not covered by doughXpress®, unless pre-authorized by doughXpress®. In the event of a defect, doughXpress®, at its option, will repair, replace or substitute the defective item at no cost during this period subject to the limitations of insurance and shipping costs stated below.

This warranty does not cover normal wear and tear, damages due to accident, misuse/abuse, alterations or damage due to neglect, or lack of proper lubrication or maintenance. doughXpress® shall not be responsible for repairs or alterations made by any person without the prior written authorization by doughXpress®. This warranty is the sole and exclusive warranty of doughXpress® and no person, agent, distributor, or dealer of doughXpress® is authorized to change, amend or modify the terms set forth herein, in whole or in part.

In the case of a problem with the equipment identified herein, doughXpress® should be contacted during regular business hours to discuss the problem and verify an existing warranty. doughXpress® personnel will assist the customer to correct any problems which can be corrected through operation or maintenance instructions, simple mechanical adjustments, or replacement of parts. In the event the problem cannot be corrected by phone, and upon the issuance of a return authorization by doughXpress®, the equipment shall be returned to doughXpress® or an authorized service representative. All insurance, packaging and shipment/freight costs are solely the responsibility of the customer, and doughXpress® shall not be responsible for improper handling or damage in transit.

doughXpress® customer service personnel may be contacted for complete return authorization and reconditioning information. This expressed warranty is given in lieu of any and all other warranties, whether expressed or implied, including but not limited to those of merchantability and fitness for a particular purpose, and constitutes the only warranty made by doughXpress®. In no event shall doughXpress® liability for breach of warranty extend beyond the obligation to repair or replace the nonconforming goods. doughXpress® shall not be liable for any other damages, either incidental or consequential, or the action as brought in contract, negligence or otherwise.

This warranty gives you specific legal rights and you may also have other rights which vary from state to state.

