

# OPERATOR'S MANUAL

## N-680 / N880

Manual Clamshell with Pressure Readout  
15"x15" & 16"x20" Heat Transfer Machines

***EVO PRO***  
***AIR AUTOMATIC***



N880



N680 photo coming soon

N680 photo coming soon

For Customer Service:  
Call 1-800-835-0606 or Visit [hixcorp.com](http://hixcorp.com)

**HIX** CORPORATION



# CONTENTS

<i>Receiving &amp; Setup</i> .....	3
<i>Power</i> .....	4
<i>User Adjustable Settings</i> .....	5
<i>Machine Presets</i> .....	6
<i>Platen Pressure</i> .....	7
<i>Transfer Application</i> .....	8
<i>Troubleshooting</i> .....	9-12
<i>Repairs</i> .....	13
<i>Maintenance</i> .....	13
<i>Parts List</i> .....	14-17
<i>Warranty</i> .....	18

BEFORE warranty repair you MUST get Prior Authorization



Intertek



Certified Green

# RECEIVING & SETUP

## SHIPPING OR RETURNS

**\*NOTE\*** *Save all of your shipping/packing material. Do not risk costly shipping damage, ship only in original box.*

1. Fasten machine to plywood shipping base with bolts provided.
2. Tie or tape handle securely to base.
3. Place in original box, and put side liner and top liner in place. Fold flaps and seal the box. (Additional bottom boards, box and liners may be obtained from your supplier for a normal cost.)

## UNPACKING

1. Remember to save all packing material - including box, liner and board. You may need these for shipping your machine or if a repair is necessary in the future.
2. When unboxing machine remove parts packaged from handle (rubber feet, air filter and fitting adapter) and install.

## INSPECTION

Inspect your machine for hidden shipping damage. Contact the delivery company immediately, should you find damage.

## INSTALLATION

1. Unpackage and install air filter and filter adapter on back of machine.
2. Remove plywood shipping base bolts (see A and B) and screw on rubber feet provided.

**CAUTION:** Handle must be tied to base before moving or shipping.

3. Carefully cut tape/wrap holding the machine closed.
4. Plug the machine into the correct grounded electrical outlet.

**WARNING:** When using an extension cord, use 12 or 14 ga.-3 conductor. Maximum length, 25' (7.762 m).

5. Supply a clean (void of oils) and dry (void of water) air source of 100-125 P.S.I. (6.8-8.5 bar) to the 1/4" NPT air inlet located on the left side panel (as viewed from the front) of the machine. Requires 1-1/2 to 2 CFM. It is strongly recommended that an external air filter and water trap be installed at the machine's air inlet connection. Compressed air is dirty. It has 'stuff', primarily moisture, residues from oil and smoke and whatever else is in the air. Compressors or 'shop air' may have filtered air and/or an "AIR DRYER" after the compressor. IF your air is not filtered and dried, YOU MUST FILTER THE AIR and REMOVE THE WATER AND 'STUFF' FROM THE AIR, before putting it in most air operated machines, including our press. There are small valves and ports that can become blocked from moisture and residue in compressed air, causing your press to malfunction. An external air filter and water trap must be installed at the machine's air inlet connection, if your air is not filtered. Damage to the machine's internal air operated components can occur that will not be covered under warranty. Combination air filter/water traps are available at any major hardware store or may be purchased directly from HIX (part #71145). Supply airline to be 3/8" minimum I.D. up to 25' run from the compressor. Supply runs longer than 25' from the compressor requires a 1/2" I.D. airline.

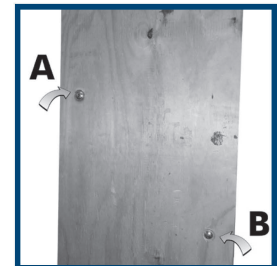

# POWER

## TURNING THE POWER “ON”

1. Once the machine is plugged into power, the display will show a “Red Icon” as shown below. To turn the power on to the machine, simply press the Red Icon.

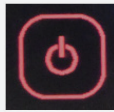

2. The display will then come on and look similar to what is shown below.

To turn the Power “OFF” to the machine, simply press the Green “Power” Icon in the upper right corner of the display and the machine will turn “OFF.”



To adjust the temperature or time settings, simply press the “UP” or “DOWN” arrows to change the values.

As the temperature is warming up from a cold start, the temperature digits will be RED when the heat platen temperature is more than 10 degrees away from desired setpoint temperature.

When the platen temperature is less than 10 degrees, but more than 5 degrees from the desired setpoint the temperature displayed will be YELLOW.

When the platen temperature displayed is within 5 degrees of the desired setpoint, the temperature digits will be GREEN.

When the actual platen temperature reaches the setpoint, the controller will BEEP.

3. A little “Red Dot” shown above in the lower left corner of the temperature display window represents the “Heat Light.” This indicator will be on when the controller is applying power to the heating element. It is normal for this indicator to flash on and off as heat is required.

# USER ADJUSTABLE SETTINGS

## USER ADJUSTABLE SETTINGS

Pressing the “GEAR” Icon  in the upper left corner of the Home Screen will switch the screen to the user settings menu, shown below.

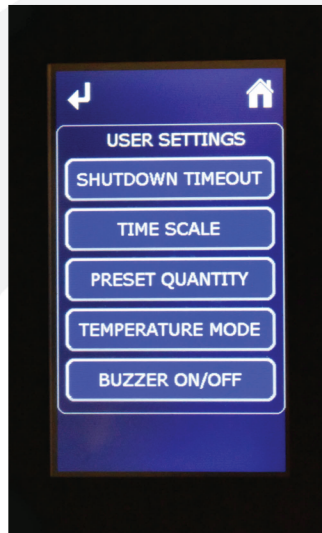

Pressing the “Back Arrow” Icon in the upper left corner of the display will take you to the previous screen.

Pressing the “Home” Icon in the upper right corner of the display will take you to the “HOME” Screen.

Pressing any of the USER SETTINGS buttons will take you to one of the screens shown below where you can adjust the machine settings to your preferences.

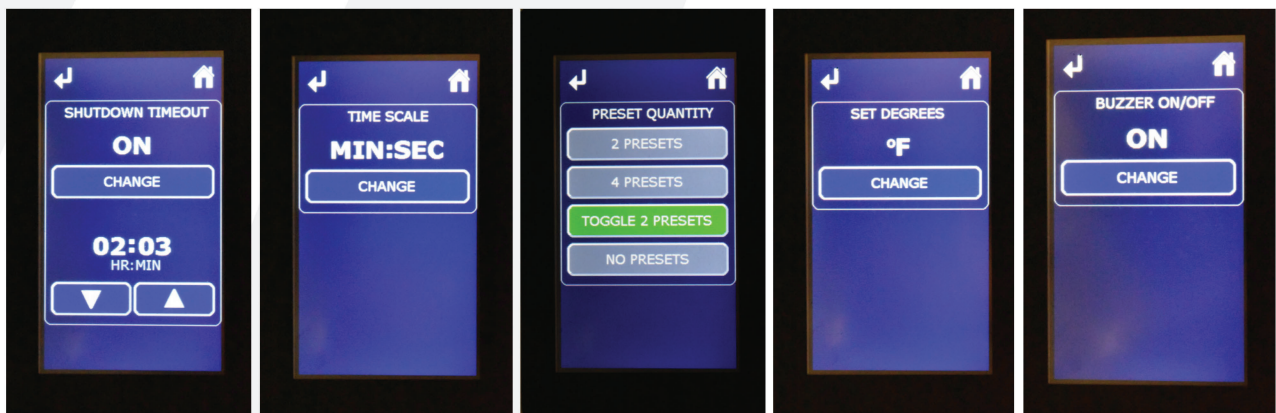

Once you have made the desired adjustments, press the “Back Arrow” or “Home” Icon.

Any changes in any of the settings or values you have made will be automatically stored as you leave that screen.

# MACHINE PRESETS

## PRESETS FOR TIME & TEMPERATURE SETTINGS

The controller has several Time and Temperature Preset options (No Presets, Two Presets, Four Presets, Toggle Two Presets) which are selectable in the “User Adjustable Settings” as outlined on the previous page.

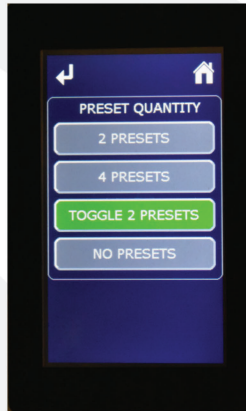

## ON THE HOME SCREEN

If one of the buttons is “GREEN” then that button is the ACTIVE time and temperature preset on the controller. See below:

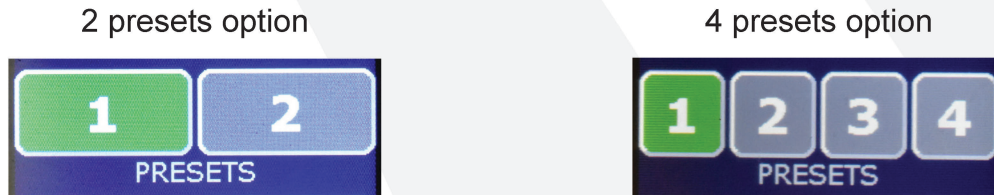

If you wish to make an adjustment to the time or temperature, simply press the UP/DOWN arrows next to the Time or Temperature values to change the number to the new setting desired.

**NOTE:** You will notice when you change either the Time or the Temperature away from the preset values, all the preset buttons will turn “Gray.”

To store the new Time or Temperature value(s) in a preset button location, simply press and HOLD on the desired preset button for 2 seconds. Once the new values are stored, the button will turn GREEN and the controller will BEEP to acknowledge the new values are stored.

To “recall” a preset, simply touch on the desired preset button and the Time and Temperature setting stored in that location will be recalled and displayed in the Time and Temperature values.

# PLATEN PRESSURE

## PRESSURE CONTROL KNOB

The air pressure control knob must be pulled out to allow for pressure adjustments then pushed in once final adjustments have been made. Set the air pressure by turning the regulator control knob and monitoring the air pressure gauge.

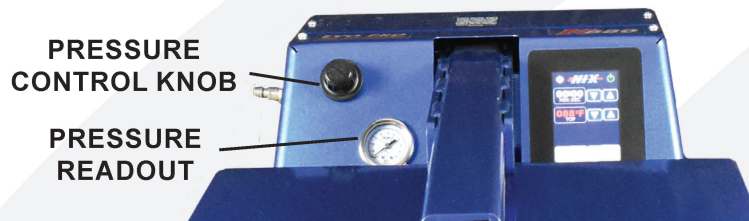

## PLATEN PRESSURE READOUT

Set the air pressure to 40 P.S.I. (pounds per square inch). Turn the control knob clockwise to increase the pressure and counterclockwise to reduce it. Refer to your transfers manufactures guide for pressure recommendations. Your machine is protected by a pressure release valve which is preset at the factory.

**NOTE:** Adjustments may be required from one garment to another and will vary to achieve the desired result.

**WARNING:** Excessive pressure can cause structural damage, voiding the machine warranty!

## PLATEN RELEASE SWITCH

The pressing cycle can be interrupted by pressing the platen release switch located under the lower platen on the right corner of the machine frame. When pressed, the air to the lifting mechanism will be released, the upper platen will open and the timer will reset.

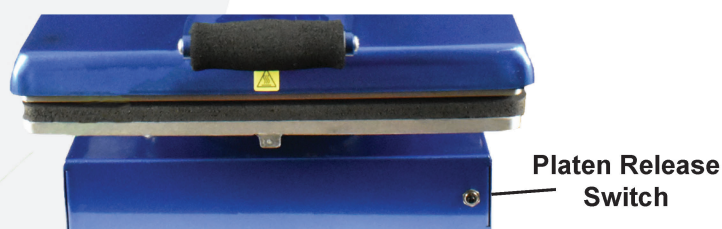

# TRANSFER APPLICATION

The **120 volt models** have a slower heat recovery (i.e. 18-20 seconds @ 375°F).

The **220 volt models** are recommended for quicker cycle times (i.e. 10 seconds @ 375°F).

1. Set the temperature, time, & pressure to the desired settings as instructed. **Always** consult your specific transfer recommendations. Typical settings are; **Cold Peel**: 350°F (177°C), 15 seconds and **Hot Split**: 375°F (190°C), 10-12 seconds.
2. Align substrate on lower platen. Smooth wrinkle from garments.

**NOTE:** Wrinkles may be removed by bringing the heated platen in contact with the garment for a few seconds before the transfer is positioned.

3. Position the transfer in the desired location on the substrate.

**NOTE:** The transfer image should be “mirrored” before transferring except when transferring to substrates where the image shows through, i.e. glass tiles and cutting boards.

**TIP:** *When transferring double sided or sublimation transfers to garments, always place a sheet of transfer paper or a PTFE sheet between the layers of the garments to avoid bleed through or reheating of the applied transfer.*

**TIP:** *When sublimating to tiles and/or cutting boards, first place a tile blanket or felt pad on lower platen, second the transfer, third the substrate and finally a PTFE blanket or transfer paper to protect the upper platen..*

4. Swing the upper heat platen over the lower platen. A stop is installed for perfect alignment between the upper and lower platen.
5. Pull the handle down until the handle locks.
6. Continuously peel the paper off the transfer and garment.

**NOTE:** Do not fold the transfer back on itself. Successful transfer work depends on the correct balance of time, temperature and pressure. The type and thickness of the material and the kind of transfer being used will determine what settings are necessary.

For hot peel/split transfers, immediately peel the paper after the machine has opened.

**DO NOT** allow the transfer to cool. For cold peel transfers, rub the transfer with an eraser or cloth and allow to cool for 5-10 seconds before removing the release paper.

# TROUBLESHOOTING

**NOTE:** Specific application instructions are enclosed with transfers.

**When you fail to make a successful transfer you can wonder, “Is it the machine’s fault, or the transfer, wrong settings or what?”**

## **FIRST, THE BASICS**

1. Be sure to set the heat transfer machine to the transfer manufacturer’s recommended Temperature, Time and Pressure settings. If you don’t have these specifications, contact your transfer supplier for this information and any other special application instructions as many of the new “High Tech” transfers require significantly different settings and/or application techniques than those from years past.
2. When you start up your press for the first time each day, preheat the pad for a minute. If the press has sat for 3-5 minutes without use, be sure to “preheat” the pad for 10-15 seconds before loading the shirt or making the first transfer.
3. After the shirt is positioned and centered on the preheated pad, “pre-press” the shirt for 3 seconds to take the wrinkles out and more importantly, release any excess moisture out of the T-shirt fabric which can reduce the chance of a successful transfer.
4. With all of the above recommendations, try making a transfer.
5. If successful, great! You are on your way to making some serious money with your transfer machine!
6. If you have an area that isn’t transferring completely or as you would like it to, follow these steps to determine the problem.
  - Try increasing the pressure on the machine by 10-20%
  - Recheck your temperature required and the press readout. You may want to increase the temperature 10 degrees.
  - Try increasing the application time by 2-4 seconds
  - If after trying these things there is still a “specific” area (say over in one corner of the transfer) that isn’t coming out as you would like it to, then try the same type transfer on a scrap shirt but rotate the transfer 180 degrees (changing the failure location) If after doing this the problem area is in the same physical location on the machine, then you probably have a problem with the pad or possibly a warped platen if the machine has ever overheated severely. On the other hand if the transfer failed in the same area on the transfer (after changing the location of where the problem had previously been occurring), then you most likely have a problem with the transfer or it’s application settings (Temperature, Time or Pressure) and you should contact your transfer supplier to discuss the problem.

Following these basic guidelines can help you be more successful with each and every transfer!

# TROUBLESHOOTING

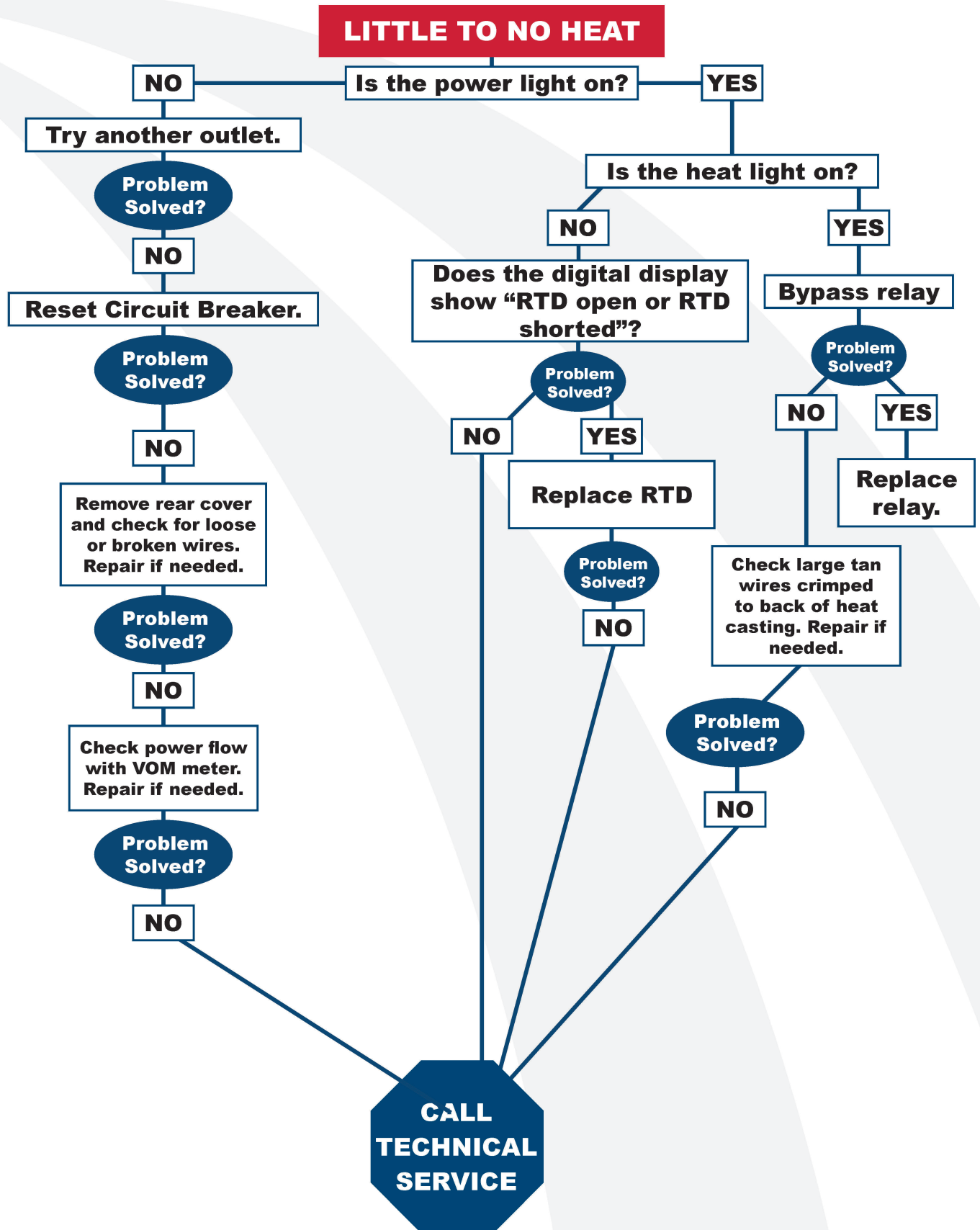

# TROUBLESHOOTING

## MACHINE OVERHEATS

Does heat light remain on constantly when overheating

NO

Problem Solved?

NO

CALL TECHNICAL SERVICE

## MACHINE WON'T STAY CLOSED

Adjust pressure

Problem Solved?

NO

CALL TECHNICAL SERVICE

# TROUBLESHOOTING

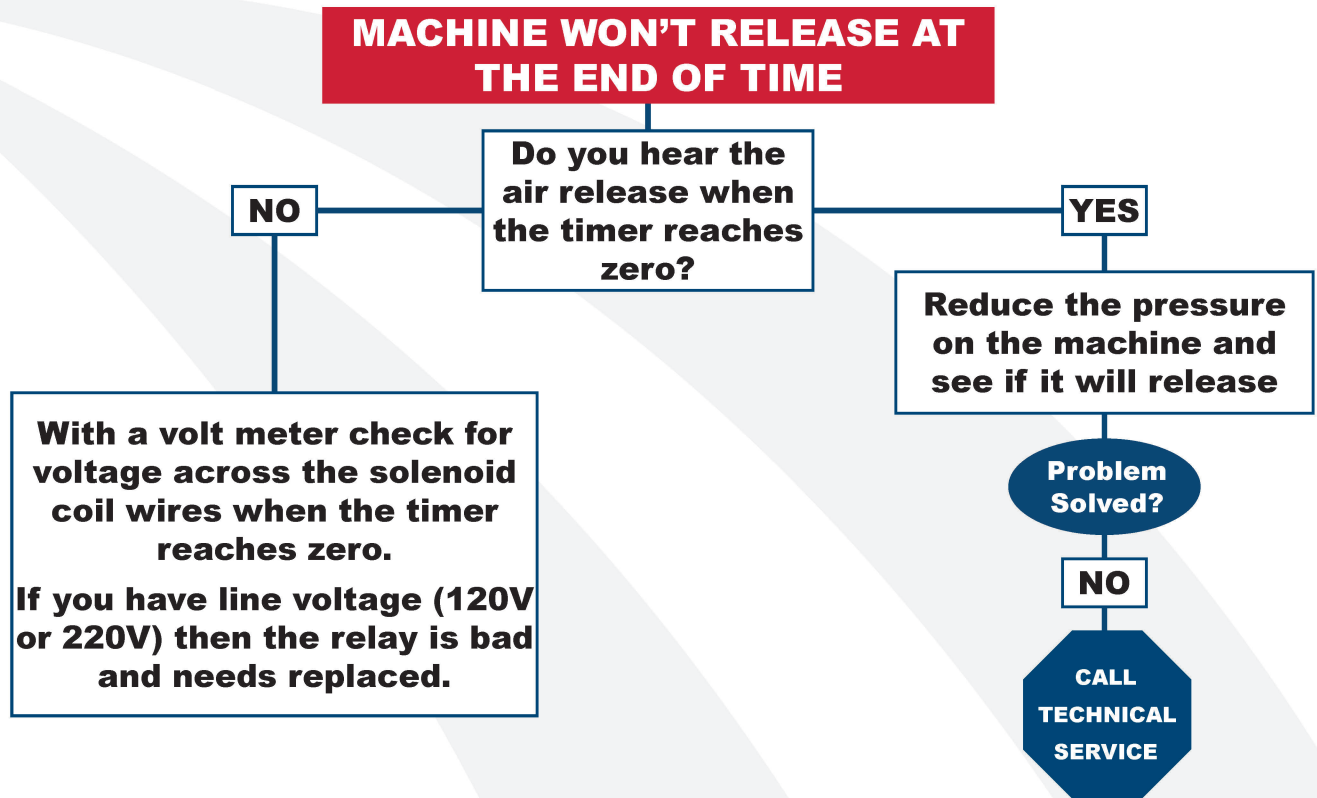

# REPAIRS

## RELAY BYPASS:

**WARNING:** Before making repairs, be sure ON/OFF switch is OFF and machine is unplugged!

1. Remove the back cover of the machine.

**WARNING:** To prevent possible electrical shock, unplug the machine before removing cover to service.

2. Remove wire #26 from terminal #2 on relay.
3. Loosen terminal #1 on relay and replace wire #26 along with wire #12 under terminal #1.
4. Tighten the connection.
5. Plug machine in and turn the power switch on.

**NOTE:** Replace the relay if the machine starts heating. This is a test only. Do not operate machine with relay bypassed.

# MAINTENANCE

## LUBRICATION:

Your press requires lubrication every 15,000 cycles or every 6 months.

Lubricate weekly in a heavy use production environment.

Use NSF/NLG12 rated food grade grease (such as Bel-Ray No-Tox #2 or equivalent).

A general purpose food grade machine oil spray is also acceptable such as CRC03055 lubricant (available from retailers such as Amazon).

Lubricate all moving or hinged points.

## CLEANING HEAT PLATEN:

Clean the heat platen with steel wool, scrubbing aluminum sponge, or fine wire brush.

# REPLACEMENT PARTS LIST (N-680 MODEL)

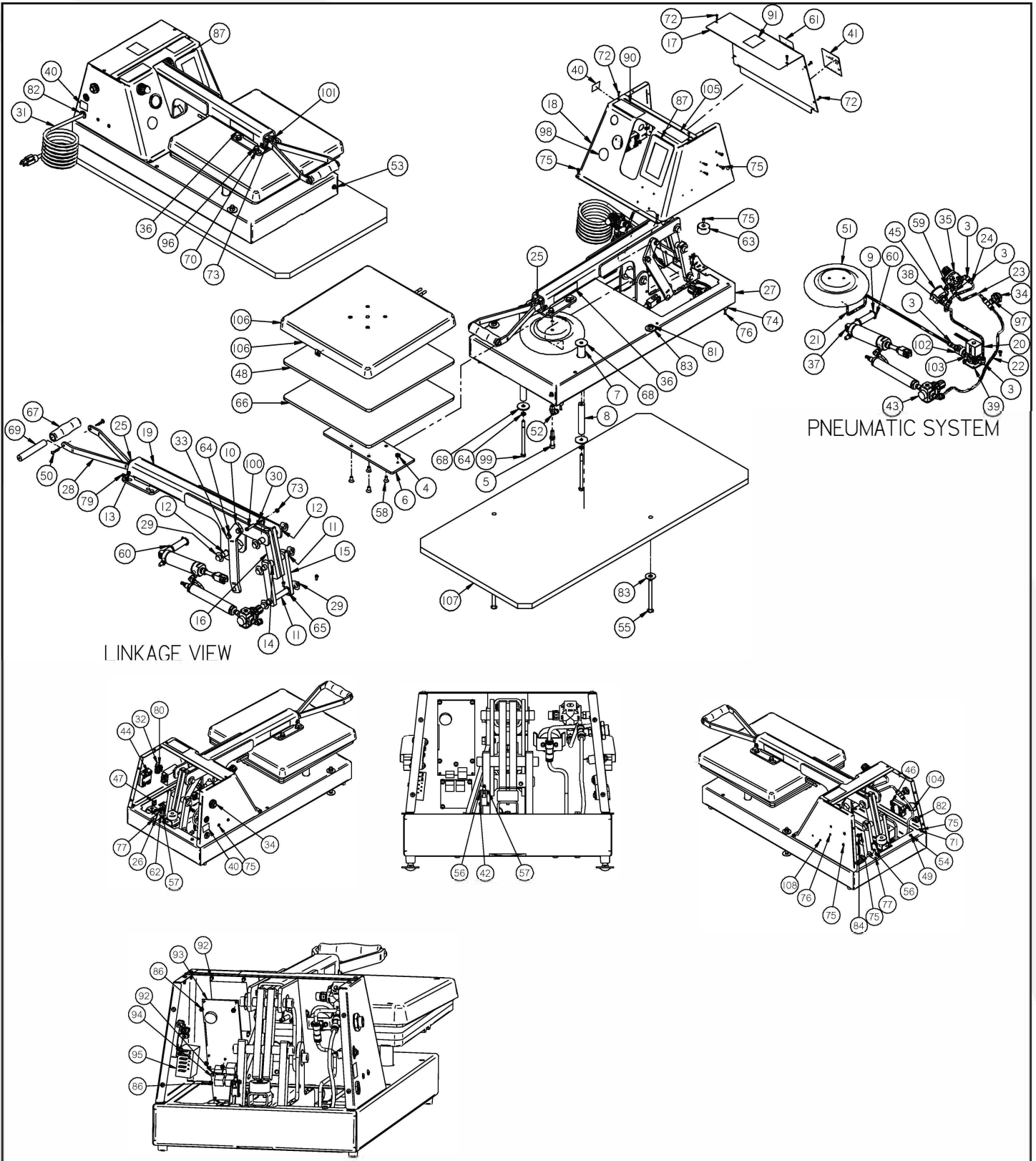

# REPLACEMENT PARTS LIST

## (N-680 MODEL)

ITEM#	PART#	TITLE	ITEM#	PART#	TITLE
1*	96577	BOXHT 680/880 NEW	55	47464	BOLT CAR 3/8-16x4.500 FTHD
2*	96258	BOXHT 680/880 LINER	56	37125	SCREW MCH 4-40x0.625 RPHH
3	90522	FTG IT EL MALE 1/4TX1/8NPT	57	36951	NUT 4-40 NYLON INSERT ZPS
4	87619	NUT 5/16-18 JAM	58	36846	SCREW FHSKT 5/16-18x0.625
5	86702	SCREW CPSKT 3/8-16x0.875	59	34274	VALVE POP-OFF 90PSI 1/8 NPT
6	8405062	M-680 PLATEN ADAPTER PLATE	60	34118	RETAINING RING EXT 0.750 E
7	8405058	M-680/880 LWR PLATEN STOP TUBE	61	33605	DECAL UNPLUG MACHINE
8	8405056	M-680/880 PLATEN GUIDE BUSHING	62	31823	SWITCH MICRO SMALL SEMI-HOOK
9	8405051	M-680/880 CYLINDER MOUNT STUD	63	31453	FOOT RUBBER 3/4X1-1/2X1/4
10	8405050	M-680/880 ARM SUPPORT LEVER	64	30910	WASHER LOCK HEL SPR 5/16 ZP
11	8405018	M-680/880 MIDDLE PIVOT PIN	65	29904	WASHER SHIM .0478x0.625x1.000
12	8405016	M-680/880 BACK PIVOT PIN	66	29899	M-CASTING 15x15 LOWER F
13	8405015	M-680/880 FRONT PIVOT PIN	67	26840	HANDLE GRIP 3/4" FOAM BLK
14	8405014	M-680/880 SPACER LINK	68	25720	WASHER FLT .406x1.500x.120 ZPS
15	8405006	M-680/880 LINK LOWER	69	2507074	M-GENERIC HTM HANDLE
16	8405005	M-680/880 DBL LINK WELDMENT	70	24732	WASHER FLT .344x0.688x.063 ZPS
17	8404118	M-ENC BACK PANEL 680/880 ANT	71	24074	WASHER FLT .219x0.500x.047 ZPS
18	8404117	O-ENCLOSURE FRONT 680/880 ANT	72	21482	SCREW TAP 8x0.500 PHPH
19	8402022	M-680/880 MAIN ARM WELDMENT	73	19186	NUT 10-24 NYLON INSERT ZPS
20	8401026	P-TUBE 0.250ODX0.170IDX12.00	74	18406	FOOT RUBBER 5/8"x1/2"
21	8401025	P-TUBE 0.250ODX0.170IDX18.75	75	15339	SCREW MCH 10-24x0.500 PHPH
22	8401024	P-TUBE 0.250ODx0.167ID 17	76	15297	SCREW MCH 6-32x0.500 PHPH
23	8401022	P-TUBE 0.250ODx0.170ID 5.5	77	15081	RIVET POP 1/8 .063-.125 STL
24	8401021	P-TUBE 0.250ODx0.170ID 7	78*	14910	DECAL HOT SURFACE SYMBOL
25	8400140	P-680/880 HANDLE LINK W/ BUSH	79	14738	NUT PUSH 5/16
26	8400139	M-BRKT LIMIT SWCH 680/880 ANT	80	14621	NUT 6-32 ZPS
27	8400133	M-FRAME WLDMT 680/880 ANT	81	14571	NUT 3/8-16 ZPS
28	8400120	M-680/880 HANDLE ASSY	82	13250	CORD GRIP HEYCO 1857 RDD201
29	82368	NUT PUSH 5/8 AU-VE-CO 14174	83	12229	WASHER FLT .500x1.250x.078 ZPS
30	79426	WASHER LOCK HEL SPR 1/4 ZP	84	11551	CABLE TIE MNT-150 7-31/32
31	74609	CORDSET 120V 16/3 SJOW 5-15P	85*	11544	CABLE TIE CT4S-M 3-3/4
32	72223	TERM BD 601-2-KT37, 38,39	86	11349	NUT 6-32 EXT TOOTH LOCK ZPS
33	71498	BOLT 5/16-18x0.750 G8	87	11314	DECAL ANTI-GLARE 4.3" ANT
34	71161	FTG BULKHD 1/4NPT BRS	88*	11208	MANUAL OWNERS 680/880 ANT
35	71153	REGULATOR 1/8NPT R261	89*	11160	WIRE KIT N-680 120V ANT
36	70732	DECAL HIX LOGO 4"x1"	90	11027	DECAL SILVER/RED EVO AIR AUTO
37	70726	RETAINING RING EXT 0.375 E	91	10963	DECAL QR CODE DXP ANT
38	70517	FTG IT TEE BRCH 1/4TX1/8FPT	92	10914	SPACER .140x.250X.125 NYLON
39	70515	VALVE SOLENOID VX3130-120V	93	10911	CONTROL DISPLAY BD 4.3" COLOR
40	70362	DECAL CERTIFIED GREEN	94	10910	CONTROL TEMP I/O BOARD ANT
41	70268	DECAL HIX I.D. 3"x3" SILVER	95	10903	POWER SUPPLY 5VDC 15W
42	70128	WASHER FLT .125x0.313x.025 ZPS	96	10769	BOLT 5/16-18x1.000
43	70010	O-680/880 D REGULATOR ASSEMBLY	97	10707	FTG 1T TEE BRCH 1/4Tx1/4 NPT
44	65897	RELAY SS 50A3-32VDC INPUT	98	10664	DECAL MADE IN THE USA ROUND
45	65300	AIR GUAGE 0-100PSI 1-1/2	99	10603	BOLT 5/16-18x5.000 G8
46	62731	RELAY SS 25A 3-32VDC INPUT	100	10561	BOLT SHOULDER 1/4x1-1/4x10-24
47	62448	WIRE CABLE CLIP ADHESIVE BACK	101	10553	BOLT SHOULDER 1/4x3/4x10-24
48	6010062	M-PAD 15x15x3/8 MED BLK MOLDED	102	10397	VALVE QUICK EXHAUST
49	59886	SCREW TAP 10-32x0.500 WHHX	103	10375	FTG NPL 1/8NPTxCLS NY HEX
50	59816	SCREW TAP 14x1.250 PHPH	104	10347	CIRCUIT BKR 1-POLE PTR 15A ST
51	57045	SPRING AIR 680/880	105	10128	DECAL N-680 SILVER/RED
52	50682	FTG 1T EL MALE 1/4Tx1/4NPT	106	0101031	M-ASSY PLATEN 15X15 120V ANT
53	50547	SWITCH PB BLK 1NC	107	0101011	M-680/880 MOUNTING BOARD
54	50189	WASHER LOCK INT TH #10 SS	108	10909	SCREW MCH M3-0.5X3 PHP ZPS

# REPLACEMENT PARTS LIST (N-880 MODEL)

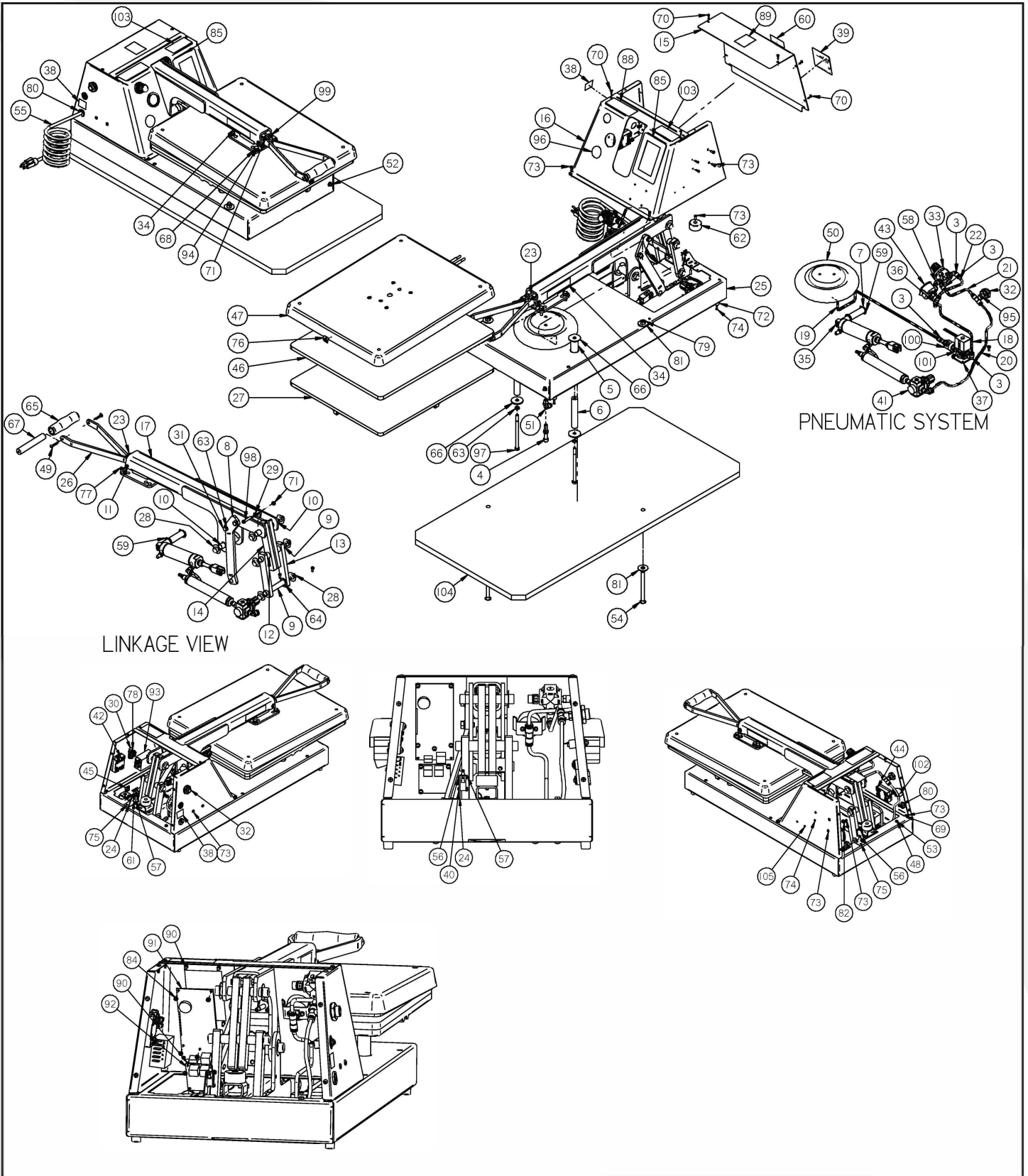

# REPLACEMENT PARTS LIST

## (N-880 MODEL)

ITEM#	PART#	TITLE	ITEM#	PART#	TITLE
1*	96577	BOXHT 680/880 NEW	55	39768	CORDSET 120V 14/3 STOW 5-15P
2*	96258	BOXHT 680/880 LINER	56	37125	SCREW MCH 4-40x0.625 RHPH
3	90522	FTG IT EL MALE 1/4TX1/8NPT	57	36951	NUT 4-40 NYLON INSERT ZPS
4	86702	SCREW CPSKT 3/8-16x0.875	58	34274	VALVE POP-OFF 90PSI 1/8 NPT
5	8405058	M-680/880 LWR PLATEN STOP TUBE	59	34118	RETAINING RING EXT 0.750 E
6	8405056	M-680/880 PLATEN GUIDE BUSHING	60	33605	DECAL UNPLUG MACHINE
7	8405051	M-680/880 CYLINDER MOUNT STUD	61	31823	SWITCH MICRO SMALL SEMI-HOOK
8	8405050	M-680/880 ARM SUPPORT LEVER	62	31453	FOOT RUBBER 3/4X1-1/2X1/4
9	8405018	M-680/880 MIDDLE PIVOT PIN	63	30910	WASHER LOCK HEL SPR 5/16 ZP
10	8405016	M-680/880 BACK PIVOT PIN	64	29904	WASHER SHIM .0478x0.625x1.000
11	8405015	M-680/880 FRONT PIVOT PIN	65	26840	HANDLE GRIP 3/4" FOAM BLK
12	8405014	M-680/880 SPACER LINK	66	25720	WASHER FLT .406x1.500x.120 ZPS
13	8405006	M-680/880 LINK LOWER	67	2507074	M-GENERIC HTM HANDLE
14	8405005	M-680/880 DBL LINK WELDMENT	68	24732	WASHER FLT .344x0.688x.063 ZPS
15	8404118	M-ENC BACK PANEL 680/880 ANT	69	24074	WASHER FLT .219x0.500x.047 ZPS
16	8404117	O-ENCLOSURE FRONT 680/880 ANT	70	21482	SCREW TAP 8x0.500 PHPH
17	8402022	M-680/880 MAIN ARM WELDMENT	71	19186	NUT 10-24 NYLON INSERT ZPS
18	8401026	P-TUBE 0.250ODX0.170IDX12.00	72	18406	FOOT RUBBER 5/8"x1/2"
19	8401025	P-TUBE 0.250ODX0.170IDX18.75	73	15339	SCREW MCH 10-24x0.500 PHPH
20	8401024	P-TUBE 0.250ODx0.167ID 17	74	15297	SCREW MCH 6-32x0.500 PHPH
21	8401022	P-TUBE 0.250ODx0.170ID 5.5	75	15081	RIVET POP 1/8 .063-.125 STL
22	8401021	P-TUBE 0.250ODx0.170ID 7	76	14910	DECAL HOT SURFACE SYMBOL
23	8400140	P-680/880 HANDLE LINK W/ BUSH	77	14738	NUT PUSH 5/16
24	8400139	M-BRKT LIMIT SWCH 680/880 ANT	78	14621	NUT 6-32 ZPS
25	8400133	M-FRAME WLDMT 680/880 ANT	79	14571	NUT 3/8-16 ZPS
26	8400120	M-680/880 HANDLE ASSY	80	13250	CORD GRIP HEYCO 1857 RDD201
27	82768	M-CASTING 16x20 LOWER F	81	12229	WASHER FLT .500x1.250x.078 ZPS
28	82368	NUT PUSH 5/8 AU-VE-CO 14174	82	11551	CABLE TIE MNT-150 7-31/32
29	79426	WASHER LOCK HEL SPR 1/4 ZP	83*	11544	CABLE TIE CT4S-M 3-3/4
30	72223	TERM BD 601-2-KT37, 38,39	84	11349	NUT 6-32 EXT TOOTH LOCK ZPS
31	71498	BOLT 5/16-18x0.750 G8	85	11314	DECAL ANTI-GLARE 4.3" ANT
32	71161	FTG BULKHD 1/4NPT BRS	86*	11208	MANUAL OWNERS 680/880 ANT
33	71153	REGULATOR 1/8NPT R261	87*	11156	WIRE KIT N-880 120V ANT
34	70732	DECAL HIX LOGO 4"x1"	88	11027	DECAL SILVER/RED EVO AIR AUTO
35	70726	RETAINING RING EXT 0.375 E	89	10963	DECAL QR CODE DXP ANT
36	70517	FTG IT TEE BRCH 1/4TX1/8FPT	90	10914	SPACER .140x.250X.125 NYLON
37	70515	VALVE SOLENOID VX3130-120V	91	10911	CONTROL DISPLAY BD 4.3" COLOR
38	70362	DECAL CERTIFIED GREEN	92	10910	CONTROL TEMP I/O BOARD ANT
39	70268	DECAL HIX I.D. 3"x3" SILVER	93	10903	POWER SUPPLY 5VDC 15W
40	70128	WASHER FLT .125x0.313x.025 ZPS	94	10769	BOLT 5/16-18x1.000
41	70010	O-680/880 D REGULATOR ASSEMBLY	95	10707	FTG 1T TEE BRCH 1/4Tx1/4 NPT
42	65897	RELAY SS 50A 3-32VDC INPUT	96	10664	DECAL MADE IN THE USA ROUND
43	65300	AIR GAUGE 0-100PSI 1-1/2	97	10603	BOLT 5/16-18x5.000 G8
44	62731	RELAY SS 25A 3-32VDC INPUT	98	10561	BOLT SHOULDER 1/4x1-1/4x10-24
45	62448	WIRE CABLE CLIP ADHESIVE BACK	99	10553	BOLT SHOULDER 1/4x3/4x10-24
46	6010063	M-PAD 16x20x1/2 MED BLK MOLDED	100	10397	VALVE QUICK EXHAUST
47	6000104	M-PLATEN ASSY 16X20 120V ANT	101	10375	FTG NPL 1/8NPTxCLS NY HEX
48	59886	SCREW TAP 10-32x0.500 WHHX	102	10347	CIRCUIT BKR 1-POLE PTR 15A ST
49	59816	SCREW TAP 14x1.250 PHPH	103	10130	DECAL N-880 SILVER/RED
50	57045	SPRING AIR 680/880	104	0101011	M-680/880 MOUNTING BOARD
51	50682	FTG 1T EL MALE 1/4Tx1/4NPT	105	10909	SCREW MCH M3-0.5X3 PHP ZPS
52	50547	SWITCH PB BLK 1NC			
53	50189	WASHER LOCK INT TH #10 SS			
54	47464	BOLT CAR 3/8-16x4.500 FTHD			

# WARRANTY

**BEFORE warranty repair you MUST get Prior Authorization: Call 1-800-835-0606 Warranty will be voided otherwise.**

**(Effective 9/1/2021)**

HIX® Corporation (HIX) will automatically register the equipment on the date it was shipped to you or your distributor. If the equipment was not purchased directly from HIX, but through a distributor, please keep a copy of their sales invoice showing the serial number and date it was sold/shipped to you with this warranty. In this case, we will use the distributor's invoice date as the beginning warranty date. **STAPLE A COPY OF YOUR PROOF OF PURCHASE TO THIS WARRANTY** and keep in a safe place to provide verification of your warranty should a problem occur. Thank you.

Please fill in the following information and attach a copy of your receipt for your records.

**Date Purchased:** \_\_\_\_\_ **From:** \_\_\_\_\_  
**Model #:** \_\_\_\_\_ **Serial #:** \_\_\_\_\_

This warranty applies to Graphics equipment manufactured by the HIX® Corporation (HIX), Pittsburg, Kansas, U.S.A. HIX warrants to the original purchaser, its Heat Transfer Machines, Ovens and Dryers, Printers, Spotheters and Exposure Units, against defects in workmanship and material, except for wear and tear for a period of "One Year" from the date of purchase. HIX warrants Accessories for a period of 90 days from the date of purchase. doughXpress® products are covered under separate warranty.

In the event of a defect, HIX, at its option, will repair, replace or substitute the defective item at no cost during this warranty period subject to the limitations of insurance and shipping costs stated below (excludes labor).

In the case of heat transfer presses (except the Hobby Lite® and Large Format presses), HIX warrants the heat casting for the "Life" of the machine for the original purchaser. If a part becomes obsolete at the time for repair, and/or cannot be reasonably substituted for, HIX will credit, at half the then current list price or last recorded price, only that part toward a new machine or any product HIX offers. This credit offer shall be the sole responsibility of the HIX in the event of an obsolete part.

This warranty does not cover belts, rail tape, pads, mug wraps, canvas, rubber blankets, bulbs, glass. Warranty does not cover damages due to accident, misuse/abuse, alterations or damage due to neglect, shipping or lack of proper lubrication or maintenance. HIX shall not be responsible for repairs or alterations made by any person without the prior written authorization by HIX. This warranty is the sole and exclusive warranty of HIX and no person, agent, distributor, or dealer of HIX is authorized to change, amend or modify the terms set forth herein, in whole or in part.

In the case of a problem with the equipment identified herein, HIX should be contacted during regular business hours to discuss the problem and verify an existing warranty. HIX personnel will assist the customer to correct any problems which can be corrected through operation or maintenance instructions, simple mechanical adjustments, or replacement of parts. In the event the problem cannot be corrected by phone, and upon the issuance of a return authorization by HIX, the equipment shall be returned to HIX or an authorized service representative. All insurance, packaging and shipment/freight costs are solely the responsibility of the customer, and not that of HIX, and HIX shall not be responsible for improper packaging, handling or damage in transit. Contact HIX customer service for complete return authorization information. Correct shipping boxes are available from HIX.

This expressed warranty is given in lieu of any and all other warranties, whether expressed or implied, including but not limited to those of merchantability and fitness for a particular purpose, and constitutes the only warranty made by HIX.

In no event shall HIX's liability for breach of warranty extend beyond the obligation to repair or replace the nonconforming goods. HIX shall not be liable for any other damages, either incidental or consequential, or the action as brought in contract, negligence or otherwise.

This warranty gives you specific legal rights and you may also have other rights which vary from state to state.



1201 E. 27th Terrace • Pittsburg, KS 66762 • U.S.A.

Phone: (800) 835-0606 • Fax: (620) 231-1598

Web site: [hixcorp.com](http://hixcorp.com) • E-Mail: [support@hixcorp.com](mailto:support@hixcorp.com)