



CATALOG OF REPLACEMENT PARTS



4146 GRINDER

ML-33607	(RH) (PAINTED)
ML-33608	(LH) (PAINTED)
ML-33609	(RH) (SST)
ML-33610	(LH) (SST)

PRIOR ML'S COVERED IN THIS CATALOG

ML-19573	(RH) (PAINTED)
ML-19574	(LH) (PAINTED)
ML-19575	(RH) (SST)
ML-19576	(LH) (SST)

Table of Contents

5	SWITCH UNIT
7	CONTROL PANEL UNIT (PREVIOUS CONSTRUCTION)
9	CONTROL PANEL UNIT (CURRENT CONSTRUCTION)
11	SAFETY SWITCH UNIT
13	GRINDER UNIT (NSF)
15	PANELS, LEGS, AND MOTOR ASSEMBLY
17	PANEL HARDWARE
19	GEAR CASE AND DRIVE UNIT
21	MOTOR UNIT (1 PH.)
23	MOTOR UNIT (3 PH. - SINGLE VOLTAGE)
25	MOTOR UNIT (3 PH. - DUAL VOLTAGE)

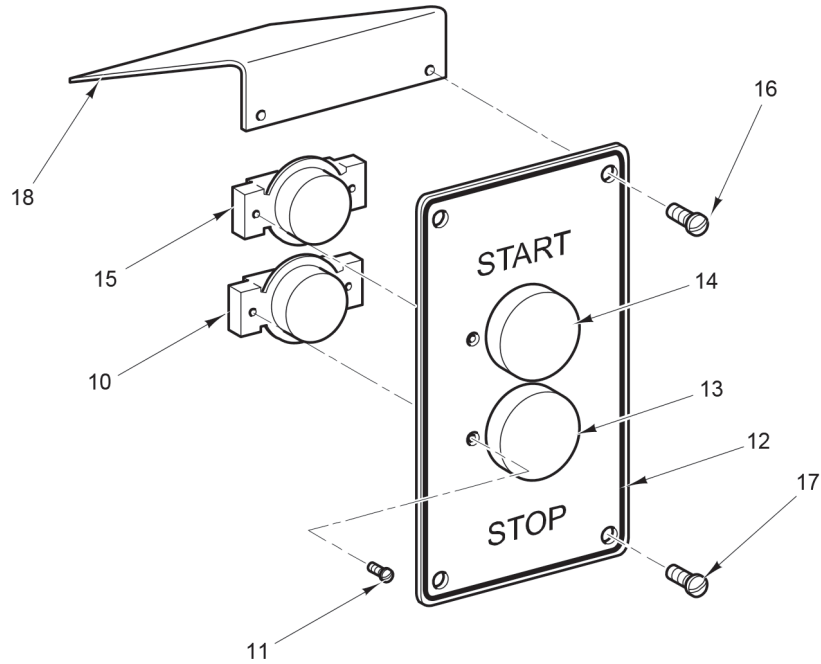
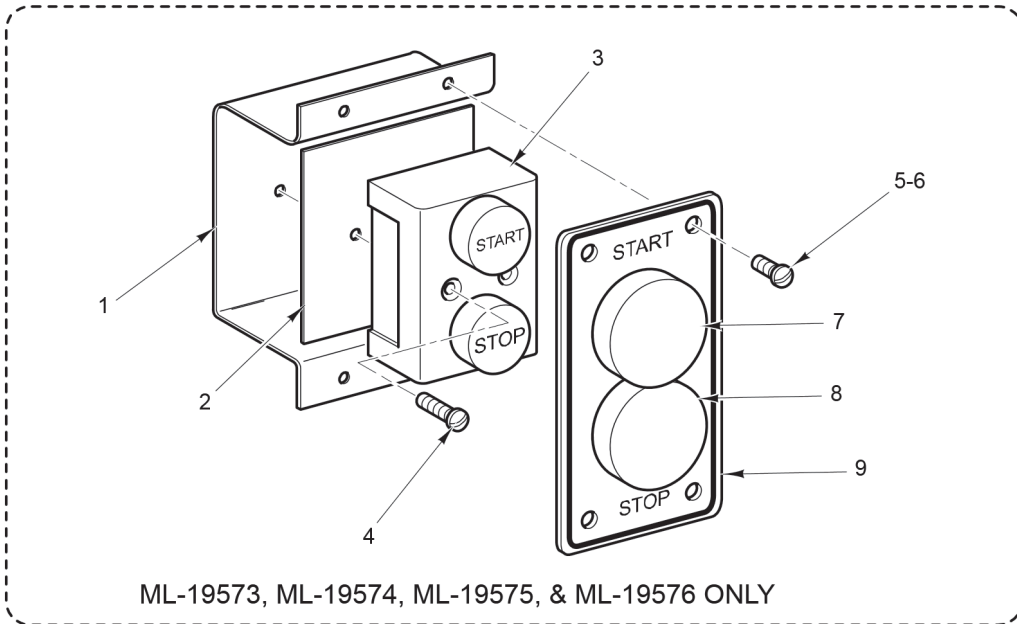

PL-60060

SWITCH UNIT

SWITCH UNIT

ILLUS.	PART NO.	NAME OF PART	AMT.
PL-60060			
1	00-068985	Bracket - Push Button Station.....	1
2	00-069485	Insulation - Push Button Station.....	1
*3		Station - Push Button.....	1
4	SC-012-74	Mach. Screw 10-32 x 3/4 Slotted Fil. Hd.....	2
5	SC-053-35	Mach. Screw 8-32 x 3/8 Slotted Truss Hd.....	4
6	00-065998	Speed Nut - Tinnerman.....	4
7	00-068984-00001	Cap - Push Button (Black).....	1
8	00-068984-00002	Cap - Push Button (Red).....	1
*9		Plate - Push Button.....	1
10	00-087711-183-2	Switch - Push Button (N.C.) (Stop).....	1
11	SC-013-12	Mach. Screw 6-32 x 1/4 Slotted Flat Hd.....	4
12	00-291727	Switch - Plate.....	1
13	00-102467-00002	Cap - Push Button (Stop) (Red).....	1
14	00-102467-00001	Cap - Push Button (Start) (Black).....	1
15	00-087711-183-1	Switch - Push Button (N.O.) (Start).....	1
16	SC-053-35	Mach. Screw 8-32 x 3/8 Slotted Truss Hd.....	2
17	SC-053-35	Mach. Screw 8-32 x 3/8 Slotted Truss Hd.....	2
18	00-293852	Shield Assy.....	1
	00-291919	Kit - Switch & Plate Assy.....	1

* Item no longer available. Order Service Kit [00-291919](#) to convert to new style.
Use new switch plate as a template to drill holes in old panels.

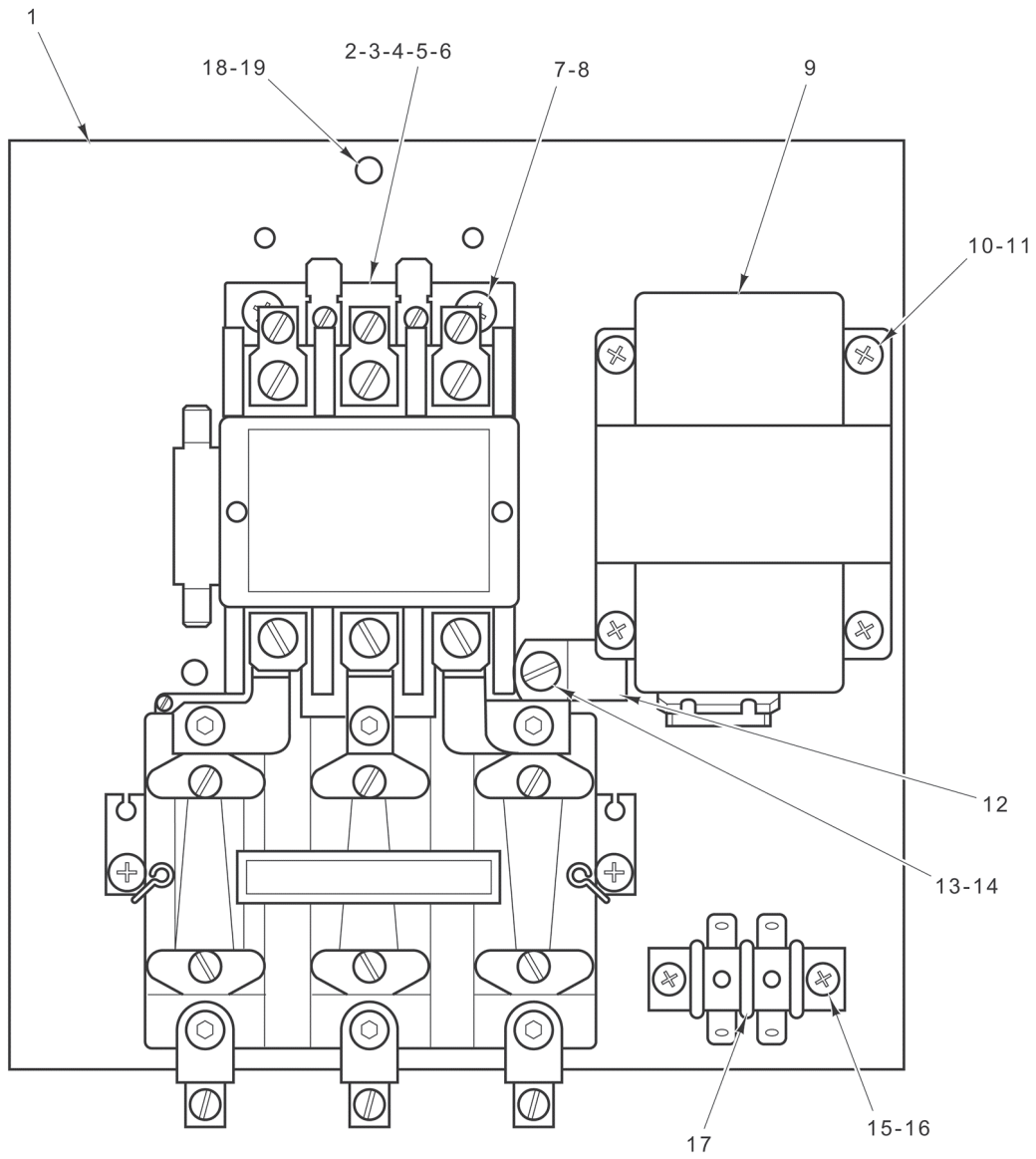

PL-60061

**CONTROL PANEL UNIT
(PREVIOUS CONSTRUCTION)**

**CONTROL PANEL UNIT
(PREVIOUS CONSTRUCTION)**

ILLUS. PL-60061	PART NO.	NAME OF PART	AMT.
1	00-123245	Panel - Control.....	1
2	00-946621-00001	Kit - Magnetic Starter Replacement (200-208 V., 60 Hz., 3 Ph.).....	1
3	00-946621-00002	Kit - Magnetic Starter Replacement (230 V., 60 Hz., 3 Ph.).....	1
4	00-946621-00003	Kit - Magnetic Starter Replacement (380 V., 50 Hz., 3 Ph.).....	1
5	00-946621-00004	Kit - Magnetic Starter Replacement (460 V., 60 Hz., 3 Ph.).....	1
6	00-087712-036-2	Starter - Magnetic (Less Elements) (1 Ph.).....	1
7	SD-015-20	Self-Tapping Screw 10-32 x 3/8 Phil. Pan Hd., Type TT.....	4
8	WL-014-07	Lockwasher #10 External Shakeproof (SST).....	4
*9	00-123449-00002	Transformer.....	1
*10	SD-015-20	Self-Tapping Screw 10-32 x 3/8 Phil. Pan Hd., Type TT.....	4
*11	WL-014-07	Lockwasher #10 External Shakeproof (SST).....	4
*12	00-078752-00002	Retainer (3/4 In.).....	1
13	SC-007-68	Mach. Screw 8-32 x 5/8 Slotted Rd. Hd.....	1
14	WL-003-14	Lockwasher #8 Helical.....	1
*15	SD-009-17	Self-Tapping Screw 8-32 x 5/8 Phil. Pan Hd., Type F.....	2
*16	WL-006-02	Lockwasher #8 Helical (SST).....	2
*17	00-117256	Block - Terminal.....	1
18	SC-007-68	Mach. Screw 8-32 x 5/8 Slotted Rd. Hd.....	2
19	WL-003-14	Lockwasher #8 Helical.....	2
**		Heater Element.....	AR

* Use with Voltage above 250.

** Give Electrical Spec., Mach., Model, & Motor Type.

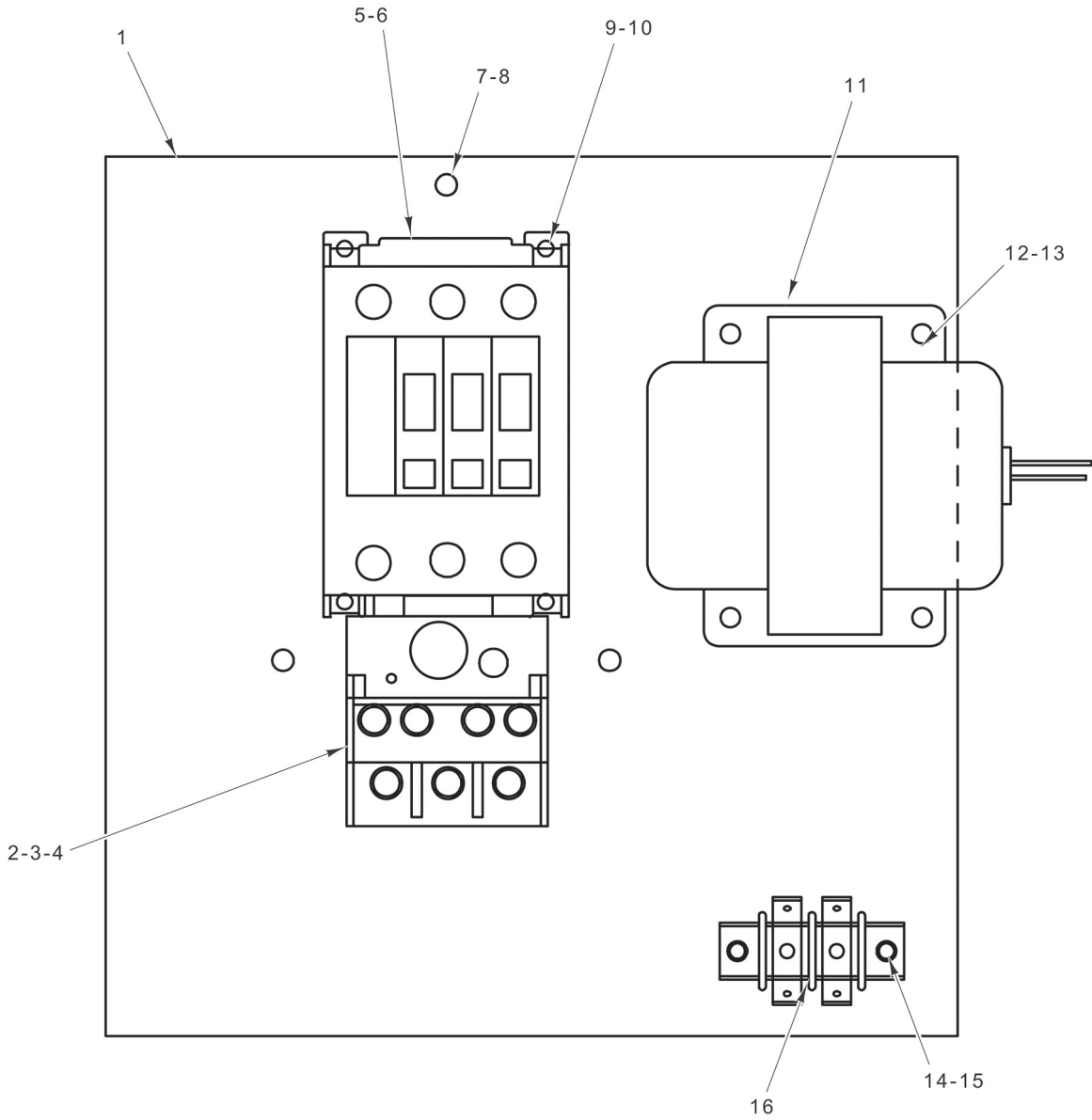

PL-60062

**CONTROL PANEL UNIT
(CURRENT CONSTRUCTION)**

**CONTROL PANEL UNIT
(CURRENT CONSTRUCTION)**

ILLUS. PL-60062	PART NO.	NAME OF PART	AMT.
1	00-946615	Panel - Control.....	1
2	00-088196-024-2	Relay - Overload (460 V., 60 Hz., 3 Ph.).....	1
3	00-088196-024-3	Relay - Overload (380 V., 50 Hz., 3 Ph.).....	1
4	00-088196-024-4	Relay - Overload (200-230 V., 60 Hz., 3 Ph.).....	1
5	00-087713-094-3	Contactor (460 V., 60 Hz., 3 Ph.) & (230 V., 60 Hz., 3 Ph.).....	1
6	00-087713-094-2	Contactor (380 V., 50 Hz., 3 Ph.) & (200-208 V., 60 Hz., 3 Ph.).....	1
7	SC-007-68	Mach. Screw 8-32 x 5/8 Slotted Rd. Hd.....	3
8	WL-003-14	Lockwasher #8 Helical.....	3
9	SD-009-17	Self-Tapping Screw 8-32 x 5/8 Phil. Pan Hd., Type F.....	4
10	WL-006-02	Lockwasher #8 Helical (SST).....	4
*11	00-123449-00002	Transformer.....	1
*12	SD-015-20	Self-Tapping Screw 10-32 x 3/8 Phil. Pan Hd., Type TT.....	4
*13	WL-014-07	Lockwasher #10 External Shakeproof (SST).....	4
*14	SD-009-17	Self-Tapping Screw 8-32 x 5/8 Phil. Pan Hd., Type F.....	2
*15	WL-006-02	Lockwasher #8 Helical (SST).....	2
*16	00-117256	Block - Terminal.....	1
	00-117612-00008	Cord & Plug Assy. (230 V.).....	1

* Use with Voltage above 250.

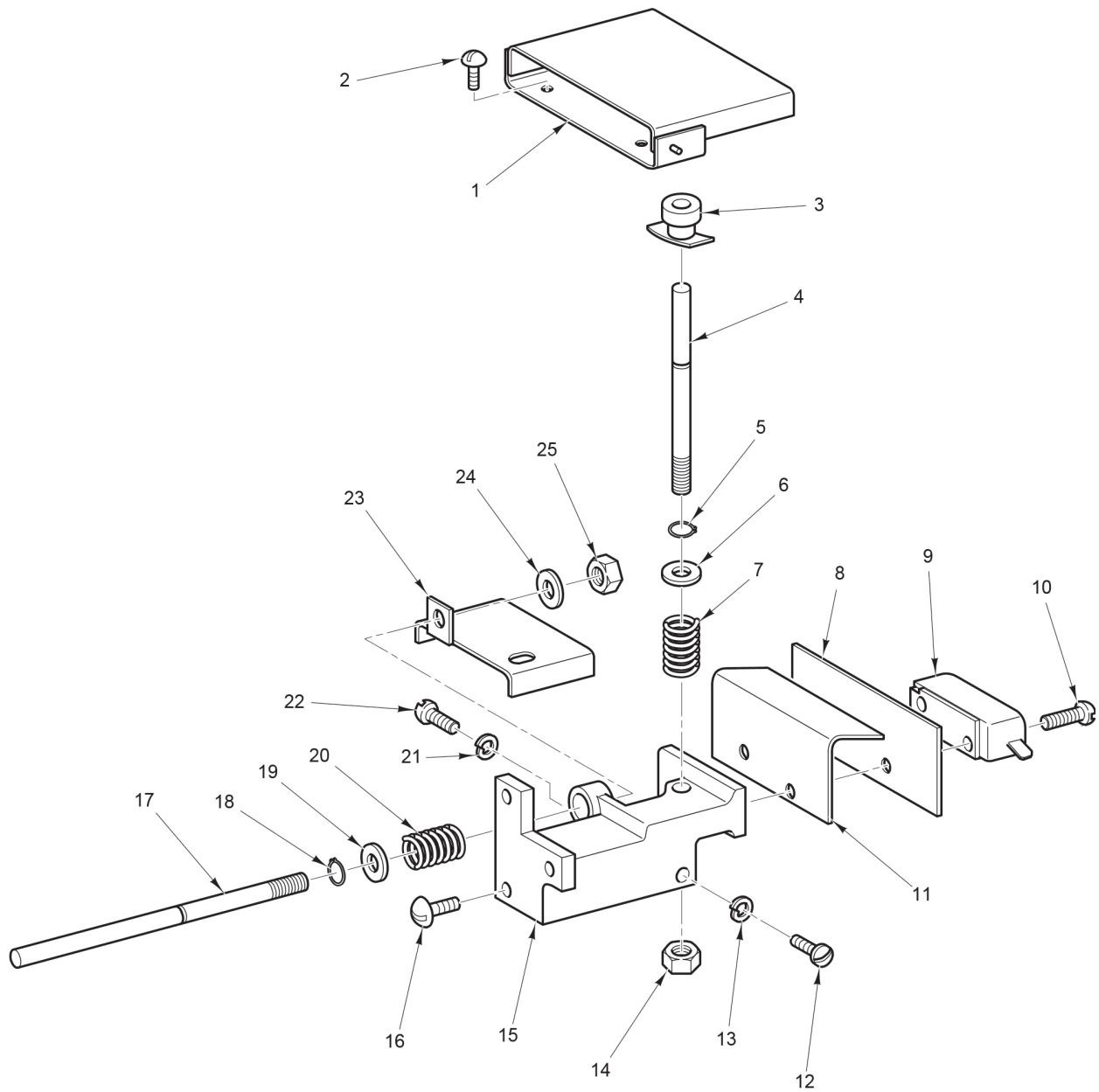

PL-60063

SAFETY SWITCH UNIT

SAFETY SWITCH UNIT

ILLUS. PL-60063	PART NO.	NAME OF PART	AMT.
1	00-068966-00002	Pan Rest Assy.....	1
2	SC-053-05	Mach. Screw 10-24 x 3/8 Slotted Truss Hd. (SST).....	2
3	00-913102-00094	Bushing & Speed Nut Assy.....	1
4	00-070574-00001	Plunger - Pan.....	1
5	RR-006-22	Retaining Ring 1/4 In. (SST).....	1
6	WS-003-49	Washer (SST).....	1
7	00-007433-00002	Spring.....	1
8	00-069679	Barrier - Safety Switch.....	1
9	00-087711-216-1	Switch - Miniature.....	1
10	SC-060-39	Mach. Screw 6-32 x 7/8 Slotted Rd. Hd.....	2
11	00-069483	Shield - Switch Drip.....	1
12	SC-021-23	Mach. Screw 10-24 x 1/2 Rd. Hd.....	1
13	WL-006-06	Lockwasher #10 Helical (SST).....	1
14	NS-031-19	Stop Nut 1/4-20 Hex (SST).....	1
15	00-068986	Bracket - Safety Switch.....	1
16	SC-053-05	Mach. Screw 10-24 x 3/8 Slotted Truss Hd. (SST).....	3
17	00-070575-00003	Plunger - Cylinder.....	1
18	RR-006-22	Retaining Ring 1/4 In. (SST).....	1
19	WS-017-09	Washer (SST).....	1
20	00-007433-00002	Spring.....	1
21	WL-006-06	Lockwasher #10 Helical (SST).....	1
22	SC-021-23	Mach. Screw 10-24 x 1/2 Rd. Hd.....	1
23	00-069406	Bracket - Switch Actuating.....	1
24	WS-017-10	Washer.....	1
25	NS-031-19	Stop Nut 1/4-20 Hex (SST).....	1
	00-069407-00004	Safety Switch Assy. (Incls. Items 4 thru 15 & 17 thru 25).....	1

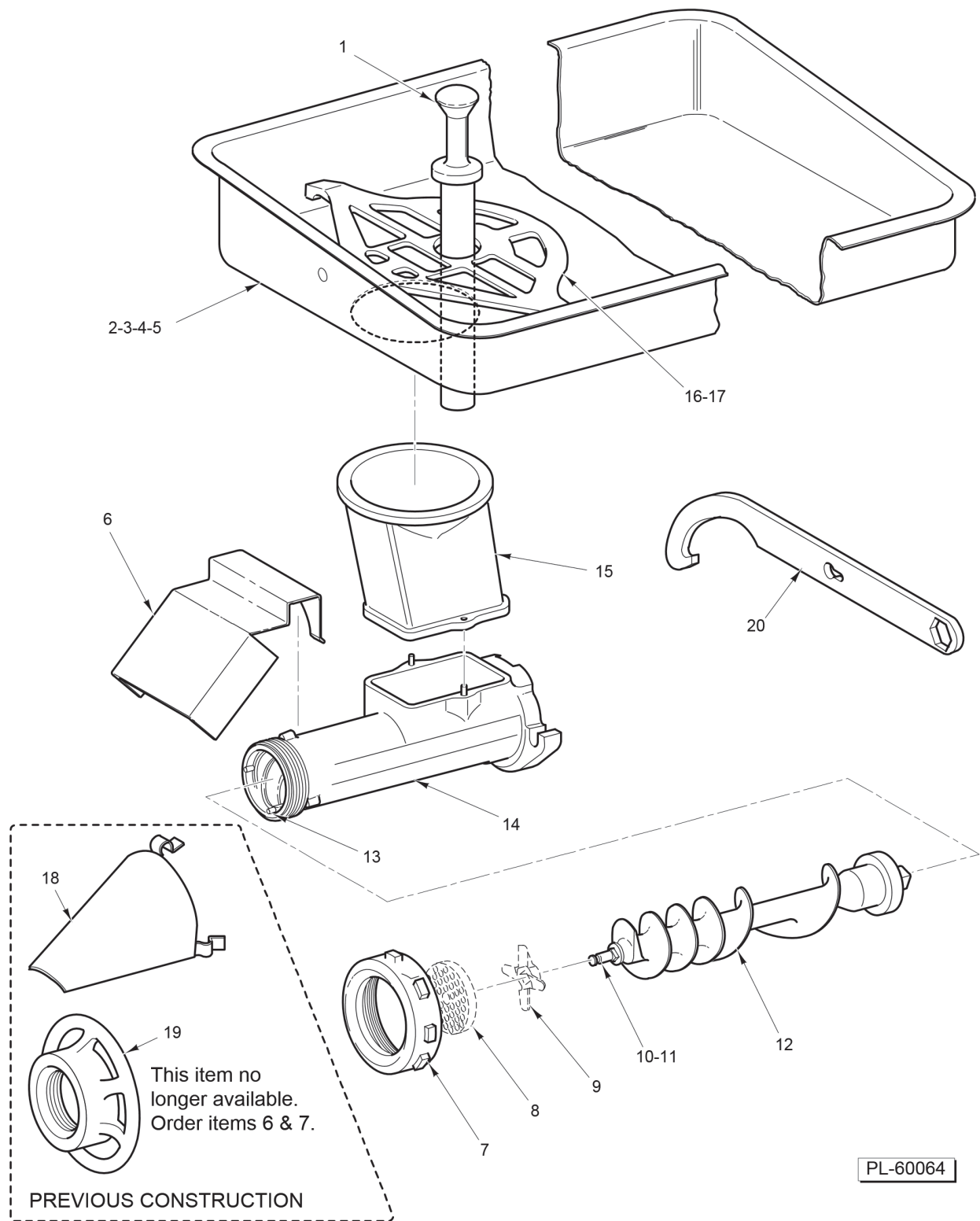

GRINDER UNIT (NSF)

GRINDER UNIT (NSF)

ILLUS. PL-60064	PART NO.	NAME OF PART	AMT.
1	00-089272-00018	Stomper - Feed (Plastic).....	1
2	00-101219-00001	Feed Pan Assy. (STL) (Opening in LH End of Machine with RH Switch Paneling).....	1
3	00-101219-00002	Feed Pan Assy. (Opening in LH End of Machine with RH Switch Paneling).....	1
4	00-101222-00001	Feed Pan Assy. (STL) (Opening in RH End of Machine with LH Switch Paneling) (Not Shown).....	1
5	00-101222-00002	Feed Pan Assy. (SST) (Opening in RH End of Machine with LH Switch Paneling) (Not Shown).....	1
6	00-875250	Meat Deflector (Packaged) (Current Construction).....	1
7	00-873697	Ring - Adjusting (Current Construction).....	1
*8		Plate.....	1
*9		Knife.....	1
10	00-110576	Stud - Plate.....	1
11	00-080982	Washer - Worm Retainer.....	1
12	00-111823	Worm Assy. (Incls. Item 10).....	1
13	00-105806	Pin - Plate.....	3
14	00-101574-00001	Cylinder Assy. (Incls. Item 13).....	1
15	00-101121	Bowl - Cylinder.....	1
**16	00-069456-00001	Bracket - Feed Pan Clamp (STL).....	1
**17	00-069456-00002	Bracket - Feed Pan Clamp (SST).....	1
18	00-080748	Meat Deflector Assy. (Previous Construction) (Use with Item 19).....	1
***19		Ring - Adjusting (Hand Wheel Type) (Previous Construction).....	1
20	00-873570	Wrench - Cylinder.....	1
	ML-016906-0000Z	Chopper Attachment Assy. (Incls. Items 6, 7, 10 thru 15, & 20).....	1

* Sharp, high quality knives and plates should be purchased or rented for this grinder.

** Welded Parts.

*** Item no longer available. Order Items 6 & 7.

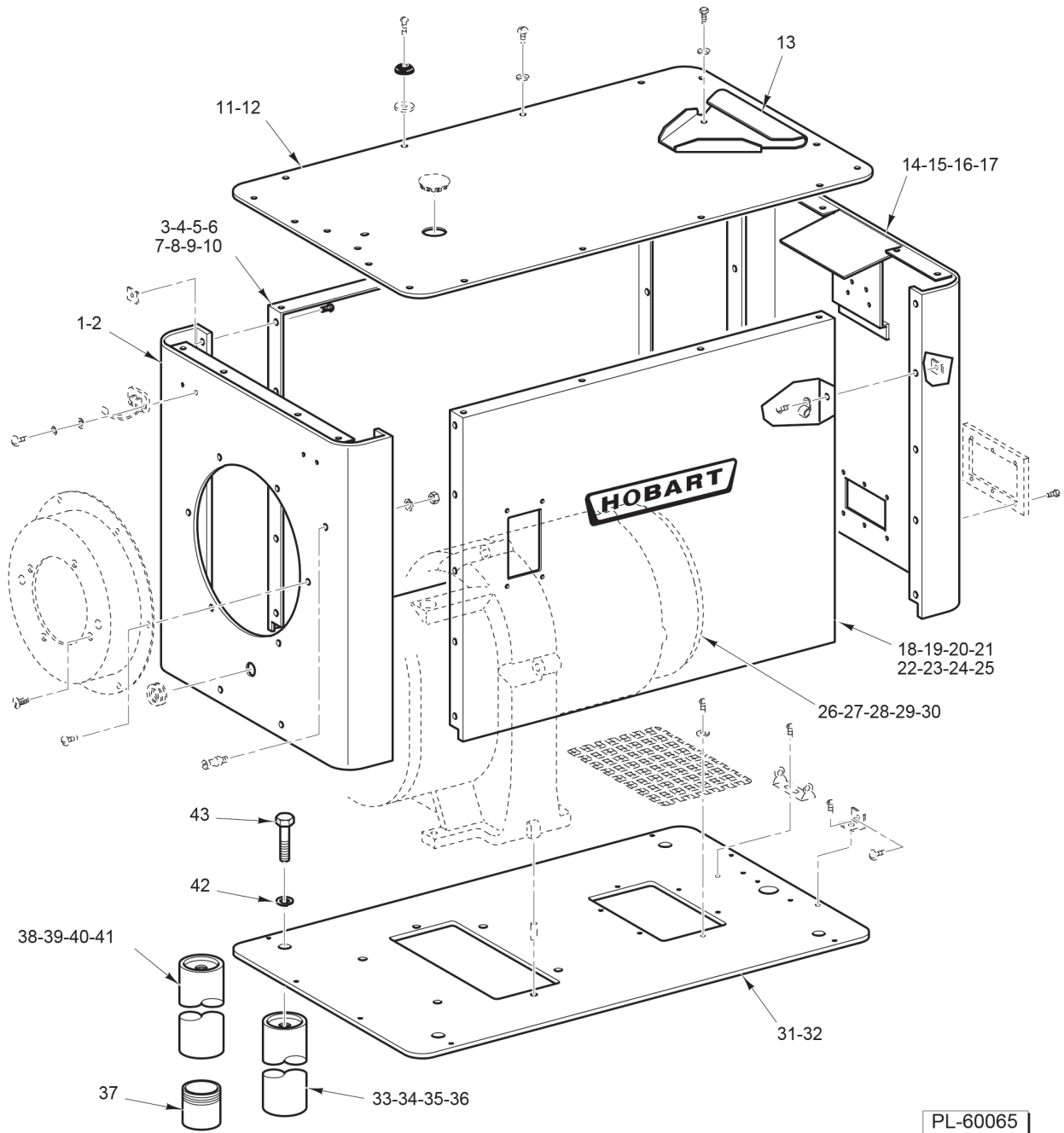

PANELS, LEGS, AND MOTOR ASSEMBLY

PANELS, LEGS, AND MOTOR ASSEMBLY

ILLUS.	PART NO.	NAME OF PART	AMT.
1	00-068975-00005	Front Sheet & Nuts Assy. (Painted).....	1
2	00-068975-00008	Front Sheet & Nuts Assy. (SST).....	1
3	00-291943-00005	Side Panel & Logo Assy. (LH) (With Switch Opening) (Painted) (60 Hz.).....	1
4	00-291943-00006	Side Panel & Logo Assy. (LH) (With Switch Opening) (SST) (60 Hz.).....	1
5	00-291943-00007	Side Panel & Logo Assy. (LH) (With Switch Opening) (Painted) (50 Hz.).....	1
6	00-291943-00008	Side Panel & Logo Assy. (LH) (With Switch Opening) (SST) (50 Hz.).....	1
7	00-291943-00009	Side Panel & Logo Assy. (Without Switch Opening) (Painted) (60 Hz.).....	1
8	00-291943-00010	Side Panel & Logo Assy. (Without Switch Opening) (SST) (60 Hz.).....	1
9	00-291943-00011	Side Panel & Logo Assy. (Without Switch Opening) (Painted) (50 Hz.).....	1
10	00-291943-00012	Side Panel & Logo Assy. (Without Switch Opening) (SST) (50 Hz.).....	1
11	00-068973-00001	Top Sheet & Weld Nut Assy. (Painted).....	1
12	00-068973-00003	Top Sheet & Weld Nut Assy. (SST).....	1
13	00-064896-00001	Bracket - Housing Hinge.....	1
14	00-103381-00001	Rear Sheet Assy. (Painted) (Previous Construction).....	1
15	00-103381-00003	Rear Sheet Assy. (SST) (Previous Construction).....	1
16	00-946690-00001	Rear Sheet Assy. (Painted) (Current Construction).....	1
17	00-946690-00002	Rear Sheet Assy. (SST) (Current Construction).....	1
18	00-291943-00001	Side Panel & Logo Assy. (RH) With Switch Opening) (Painted) (60 Hz.).....	1
19	00-291943-00002	Side Panel & Logo Assy. (RH) With Switch Opening) (SST) (60 Hz.).....	1
20	00-291943-00003	Side Panel & Logo Assy. (RH) With Switch Opening) (Painted) (50 Hz.).....	1
21	00-291943-00004	Side Panel & Logo Assy. (RH) With Switch Opening) (SST) (50 Hz.).....	1
22	00-291943-00009	Side Panel & Logo Assy. (Without Switch Opening) (Painted) (60 Hz.).....	1
23	00-291943-00010	Side Panel & Logo Assy. (Without Switch Opening) (SST) (60 Hz.).....	1
24	00-291943-00011	Side Panel & Logo Assy. (Without Switch Opening) (Painted) (50 Hz.).....	1
25	00-291943-00012	Side Panel & Logo Assy. (Without Switch Opening) (SST) (50 Hz.).....	1
26	00-278393-00001	Motor Assy. (200 V., 60 Hz., 1 Ph.).....	1
27	00-278393-00002	Motor Assy. (230 V., 60 Hz., 1 Ph.).....	1
28	00-278355-00001	Motor Assy. (200/400 V., 60 Hz., 3 Ph.).....	1
29	00-278355-00002	Motor Assy. (230/460 V., 60 Hz., 3 Ph.).....	1
30	00-278355-00003	Motor Assy. (230/400 V., 50 Hz., 3 Ph.).....	1
31	00-068956	Plate - Base (Previous Construction).....	1
32	00-946691	Plate - Base (Current Construction).....	1
33	00-068932-00001	Leg & Expansion Plug Assy. (16 In.).....	3
34	00-068932-00005	Leg & Expansion Plug Assy. (18-1/2 In.).....	3
35	00-068932-00009	Leg & Expansion Plug Assy. (22 In.).....	3
36	00-068932-00011	Leg & Expansion Plug Assy. (21 In.).....	3
37	00-068929	Foot - Adjustable Leg.....	1
38	00-074862-00001	Adjustable Leg & Foot Assy. (16 In.) (Incls. Item 37).....	1
39	00-074862-00005	Adjustable Leg & Foot Assy. (18-1/2 In.) (Incls. Item 37).....	1
40	00-074862-00009	Adjustable Leg & Foot Assy. (22 In.) (Incls. Item 37).....	1
41	00-074862-00011	Adjustable Leg & Foot Assy. (21 In.) (Incls. Item 37).....	1
42	WL-004-18	Lockwasher 5/8 Light.....	4
43	SC-062-25	Cap Screw 5/8-11 x 2-1/4 Hex Hd.....	4

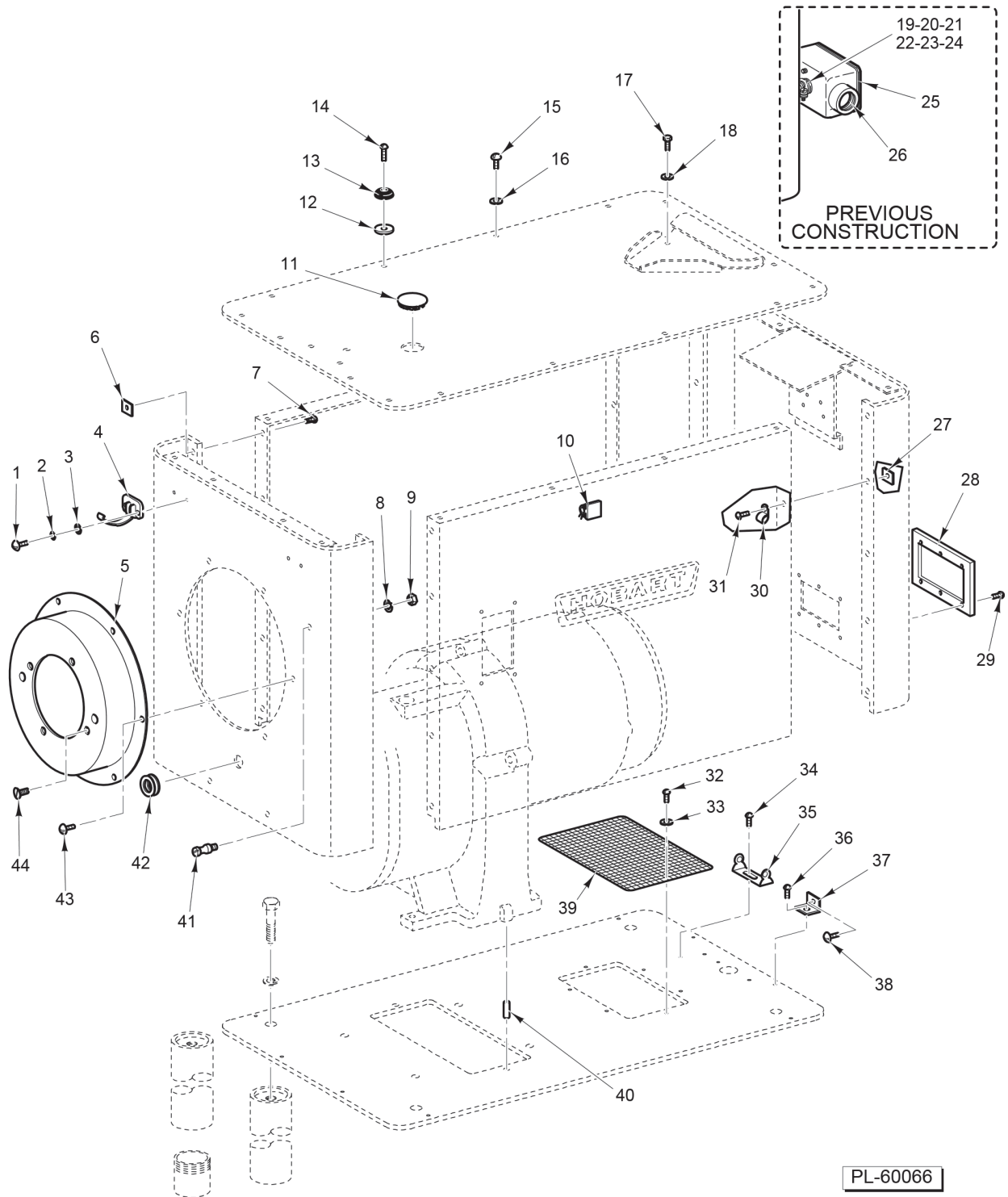

PANEL HARDWARE

PANEL HARDWARE

ILLUS. PL-60066	PART NO.	NAME OF PART	AMT.
1	SC-053-05	Mach. Screw 10-24 x 3/8 Slotted Truss Hd. (SST).....	4
2	WL-008-13	Lockwasher #10 Internal Shakeproof.....	4
3	WS-019-24	Washer.....	4
4	00-067319	Clamp - Pan.....	2
5	00-069791	Cap - Trim.....	1
6	00-069534	Speed Nut - Tinnerman.....	13
7	SC-008-09	Mach. Screw 10-24 x 3/8 Slotted Rd. Hd.....	13
8	WL-006-22	Lockwasher 5/16 Light.....	1
9	NS-015-11	Nut 5/16-18 Hex (SST).....	1
10	00-106825-00001	Clip - Wiring.....	AR
11	PB-002-27	Plug Button 1.375.....	1
12	00-063934	Washer - Shim.....	AR
13	00-019105-00002	Bumper.....	4
14	SC-021-27	Mach. Screw 10-24 x 1 Slotted Rd. Hd. (SST).....	4
15	SC-053-02	Mach. Screw 10-24 x 1/2 Slotted Truss Hd. (SST).....	12
16	WS-019-39	Washer.....	12
17	SC-041-05	Cap Screw 1/4-20 x 5/8 Hex Hd. (SST).....	2
18	WS-003-49	Washer (SST).....	2
19	FE-002-33	Connector - Straight 3/4 Male x 3/4 Flex Conduit.....	1
20	FE-007-12	Lock Nut 3/4 Electrical.....	1
21	00-118544-00001	Lug - Solderless.....	1
22	SC-060-87	Mach. Screw 10-32 x 3/4 Slotted Rd. Hd. (SST).....	1
23	WL-007-12	Lockwasher #10 External Shakeproof.....	2
24	NS-009-30	Nut 10-32 Hex.....	1
25	FE-004-21	Cover - Junction Box (Incls. Gasket).....	1
26	00-069853	Box - Junction.....	1
27	00-069534	Speed Nut - Tinnerman.....	AR
28	00-946632-00002	Cover & Gasket Assy.....	1
29	SD-015-20	Self-Tapping Screw 10-32 x 3/8 Phil. Pan Hd., Type TT.....	6
30	00-078752-00004	Retainer (7/16 In.).....	AR
31	SC-008-10	Mach. Screw 10-24 x 1/2 Slotted Rd. Hd.....	AR
32	SC-060-21	Mach. Screw 10-24 x 1/4 Slotted Rd. Hd.....	6
33	WS-002-51	Washer.....	6
34	SC-014-57	Mach. Screw 10-24 x 1/2 Slotted Flat Hd.....	4
35	00-066621-00002	Bracket - Capacitor.....	2
36	SC-009-25	Mach. Screw 10-24 x 5/8 Slotted Rd. Hd.....	8
37	00-068978	Bracket - Housing Support.....	8
38	SC-053-44	Mach. Screw 1/4-20 x 5/16 Slotted Truss Hd. (SST).....	8
39	00-068900	Screen - Air Outlet.....	1
40	00-011800-00117	Dowel.....	2
41	00-065159	Screw - Spanner Wrench Support.....	1
42	00-069492	Grommet.....	1
43	SC-053-05	Mach. Screw 10-24 x 3/8 Slotted Truss Hd. (SST).....	6
44	SC-022-19	Mach. Screw 10-24 x 1/2 Slotted Flat Hd. (SST).....	4

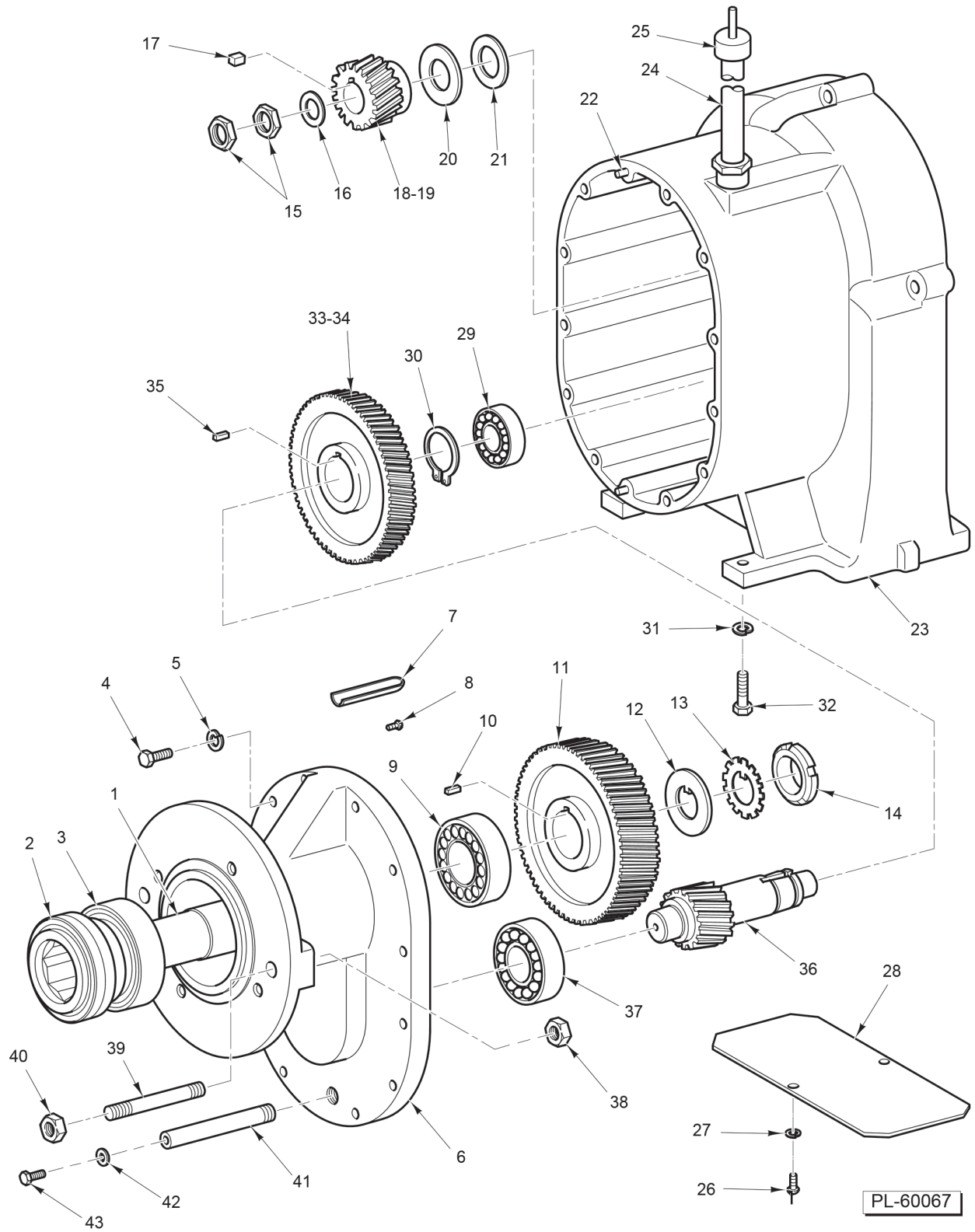

GEAR CASE AND DRIVE UNIT

GEAR CASE AND DRIVE UNIT

ILLUS.	PART NO.	NAME OF PART	AMT.
PL-60067			
1	00-069794	Shaft - Square Drive.....	1
2	00-069490	Seal - Square Drive.....	2
3	BR-002-21	Roller Bearing - Cup & Cone Assy.....	1
4	SC-062-24	Cap Screw 5/16-18 x 1-1/2 Hex Hd.....	12
5	WL-003-45	Lockwasher 5/16 Helical.....	12
6	00-118682	Hub - Attachment.....	1
7	00-116775	Conveyor - Oil.....	1
8	SC-069-02	Mach. Screw 10-32 x 5/8 Slotted Pan Hd.....	1
9	BR-002-20	Roller Bearing - Cup & Cone Assy.....	1
10	00-109070-00020	Key.....	1
11	00-069833	Gear - Drive (56T).....	1
12	00-123431	Washer - Tongue.....	1
13	WL-017-09	Lockwasher - TW107.....	1
14	NS-034-08	Lock Nut - N.D. #N-07.....	1
15	00-006566	Lock Nut.....	2
16	WS-011-24	Washer.....	1
17	00-109070-00017	Key.....	1
18	00-085812-00001	Gear - Motor Pinion (24T) (60 Hz.).....	1
19	00-085812-00003	Gear - Motor Pinion (27T) (50 Hz.).....	1
20	00-072536	Flinger - Oil.....	1
21	00-072537	Spacer - Oil Flinger.....	1
22	00-011800-00239	Dowel.....	2
23	00-085852-00002	Case - Gear.....	1
24	00-068987-00001	Tube & Bushing Assy.....	1
25	00-069477-00001	Dip Stick & Fill Cap Assy.....	1
26	SC-060-21	Mach. Screw 10-24 x 1/4 Slotted Rd. Hd.....	2
27	WL-003-20	Lockwasher #10 Light.....	2
28	00-120471	Screen - Air Inlet.....	1
29	BB-018-33	Ball Bearing - Fafnir #205KFA.....	1
30	RR-006-14	Retaining Ring 1.426 ID.....	1
31	WL-004-02	Lockwasher 3/8 Helical.....	4
32	SC-062-22	Cap Screw 3/8-16 x 1-1/4 Hex Hd.....	4
33	00-068954-00001	Gear - Main Drive (65T) (60 Hz.).....	1
34	00-068954-00003	Gear - Main Drive (62T) (50 Hz.).....	1
35	00-019070-00021	Key.....	1
36	00-068951	Pinion - Countershaft (19T).....	1
37	BB-007-21	Ball Bearing - N.D. 3207.....	1
38	NS-013-43	Nut 5/8-11 Hex.....	2
39	00-072981-00002	Stud - Cylinder (4 In. Lg.).....	2
40	NS-048-57	Nut 5/8-11 Flanged Hex.....	2
41	00-069431	Pipe - Oil Drain.....	1
42	WS-021-20	Washer.....	1
43	SC-036-93	Cap Screw 7/16-20 x 3/4 Hex Hd.....	1

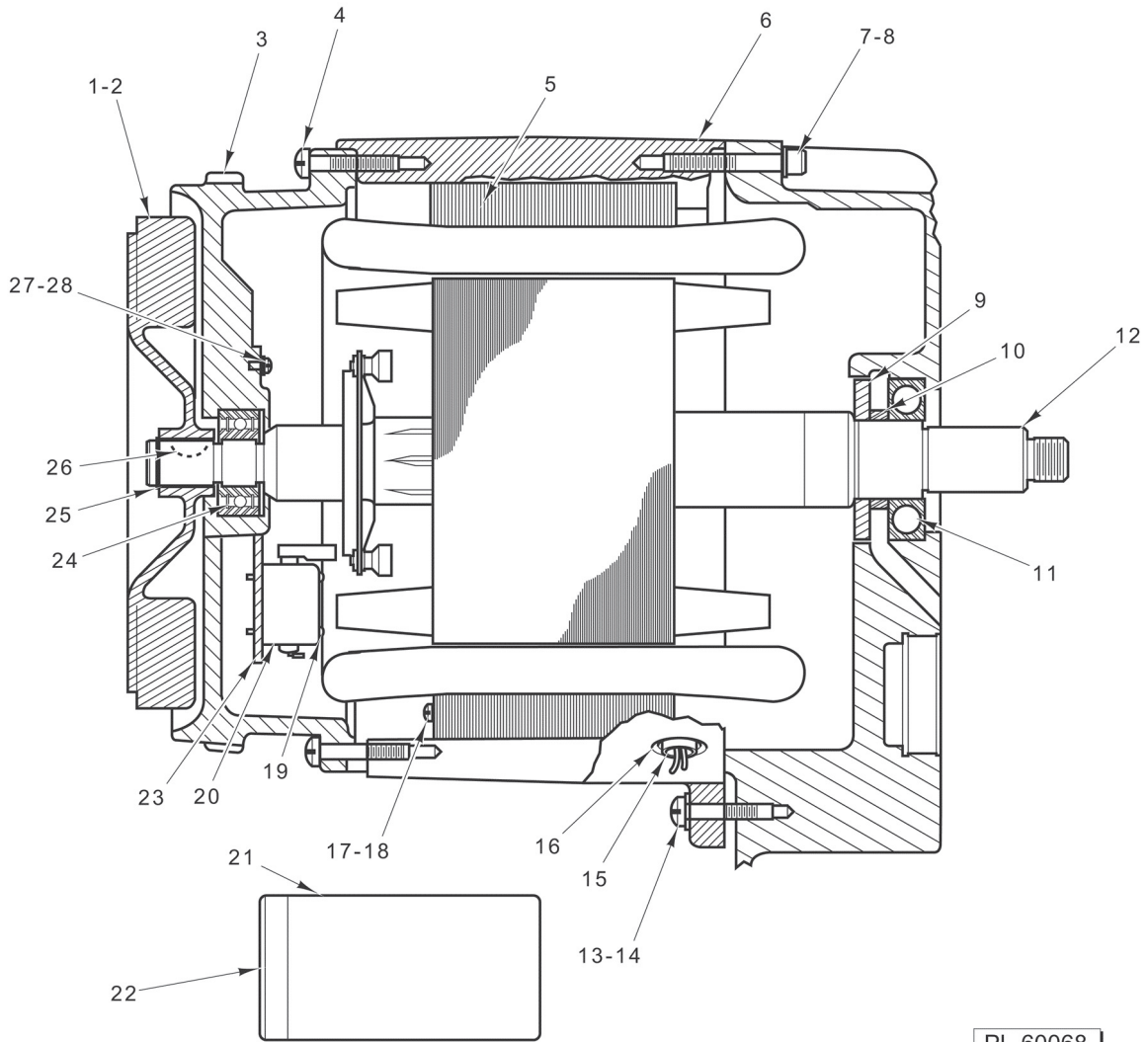

**MOTOR UNIT
(1 PH.)**

**MOTOR UNIT
(1 PH.)**

ILLUS. PL-60068	PART NO.	NAME OF PART	AMT.
1	00-275183	Fan.....	1
2	SC-047-12	Set Screw 1/4-20 x 3/8 Socket Hds., Knife Cup Pt.....	2
3	00-119466	Bracket - Bearing.....	1
4	SC-011-98	Mach. Screw 5/16-18 x 1-1/4 Slotted Fil. Hd.....	4
5	00-065477-133-1	Stator Assy. (200 V., 60 Hz., 1 Ph.).....	1
6	00-069969-00001	Field Ring.....	1
7	SC-040-74	Cap Screw 5/16-18 x 2 Socket Fil. Hd.....	3
8	WL-003-43	Lockwasher 5/16 Light.....	3
9	00-083715	Deflector - Grease.....	1
10	00-068968	Spacer - Bearing.....	1
11	BB-020-15	Ball Bearing - SKF #6207Z.....	1
12	00-022275-00221	Rotor Assy.....	1
13	WL-003-43	Lockwasher 5/16 Light.....	1
14	SC-011-98	Mach. Screw 5/16-18 x 1-1/4 Slotted Fil. Hd.....	1
15	00-069632-00001	Sleeve.....	1
16	00-006651	Bushing - Insulating.....	1
17	WS-002-15	Washer.....	8
18	SC-011-56	Mach. Screw 10-32 x 4-3/4 Slotted Fil. Hd.....	8
19	SC-009-85	Mach. Screw 6-32 x 1-1/4 Slotted Rd. Hd.....	4
20	00-117548	Switch - Starting (Stationary Part) (1 Ph.).....	1
21	00-070487-00017	Capacitor.....	2
22	00-070486-00004	End Cap.....	2
23	00-119476	Plate - Switch.....	1
24	BB-016-37	Ball Bearing - Fafnir #W204 PPC 1.....	1
25	RR-004-06	Retaining Ring.....	1
26	KW-003-10	Key - Woodruff 3/16 x 3/4.....	1
27	WL-003-14	Lockwasher #8 Helical.....	3
28	SC-012-49	Mach. Screw 8-32 x 3/8 Slotted Fil. Hd.....	3

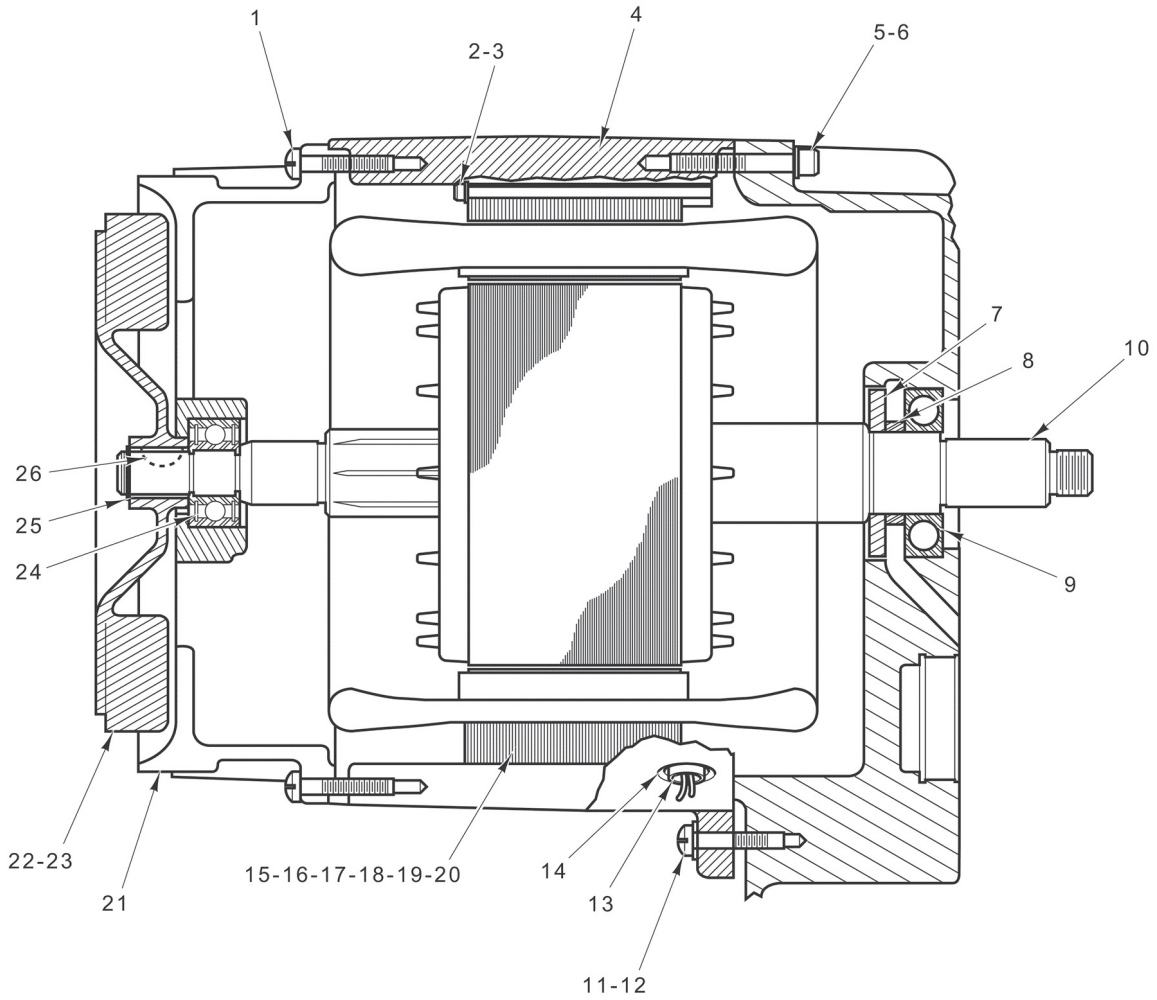

PL-60069

**MOTOR UNIT
(3 PH. - SINGLE VOLTAGE)**

**MOTOR UNIT
(3 PH. - SINGLE VOLTAGE)**

ILLUS. PL-60069	PART NO.	NAME OF PART	AMT.
1	SC-011-98	Mach. Screw 5/16-18 x 1-1/4 Slotted Fil. Hd.....	4
2	SC-012-62	Mach. Screw 10-32 x 4 Slotted Fil. Hd.....	8
3	WS-002-15	Washer.....	8
4	00-069969-00001	Field Ring.....	1
5	SC-040-74	Cap Screw 5/16-18 x 2 Socket Fil. Hd.....	3
6	WL-003-43	Lockwasher 5/16 Light.....	3
7	00-083715	Deflector - Grease.....	1
8	00-068968	Spacer - Bearing.....	1
9	BB-020-15	Ball Bearing - SKF #6207Z.....	1
10	00-015747-00302	Rotor Assy.....	1
11	WL-003-43	Lockwasher 5/16 Light.....	1
12	SC-011-98	Mach. Screw 5/16-18 x 1-1/4 Slotted Fil. Hd.....	1
13	00-069632-00001	Sleeve.....	1
14	00-006651	Bushing - Insulating.....	1
15	00-065478-045-1	Stator Assy. (200 V., 60 Hz., 3 Ph.).....	1
16	00-065478-045-2	Stator Assy. (230 V., 60 Hz., 3 Ph.).....	1
17	00-065478-045-3	Stator Assy. (460 V., 60 Hz., 3 Ph.).....	1
18	00-065478-045-4	Stator Assy. (220 V., 50 Hz., 3 Ph.).....	1
19	00-065478-045-5	Stator Assy. (380 V., 50 Hz., 3 Ph.).....	1
20	00-065478-045-6	Stator Assy. (575 V., 60 Hz., 3 Ph.).....	1
21	00-064372	Bracket - Bearing.....	1
22	00-275183	Fan.....	1
23	SC-047-12	Set Screw 1/4-20 x 3/8 Socket Hdls., Knife Cup Pt.....	2
24	BB-016-37	Ball Bearing - Fafnir #W204 PPC 1.....	1
25	RR-004-06	Retaining Ring.....	1
26	KW-003-10	Key - Woodruff 3/16 x 3/4.....	1

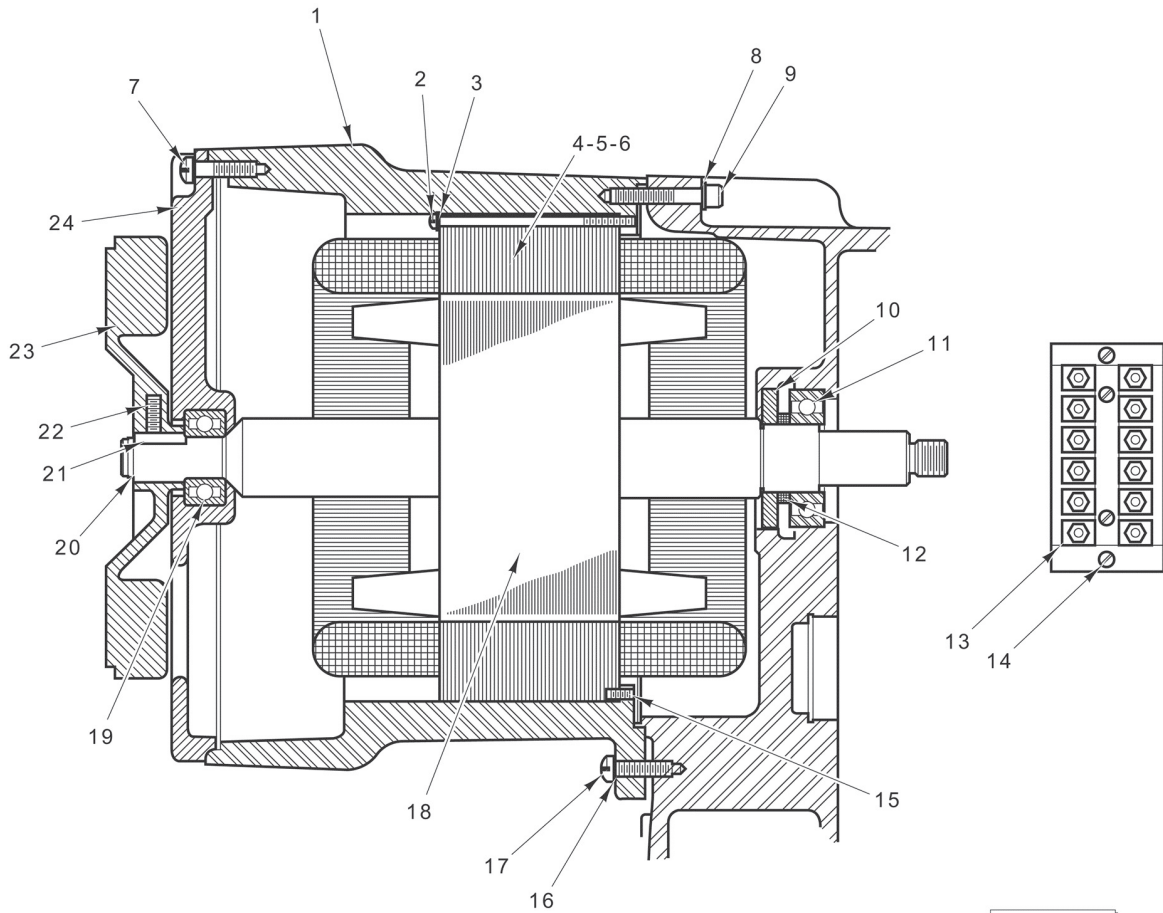

**MOTOR UNIT
(3 PH. - DUAL VOLTAGE)**

**MOTOR UNIT
(3 PH. - DUAL VOLTAGE)**

ILLUS. PL-60070	PART NO.	NAME OF PART	AMT.
1	00-275156-00002	Ring - Field.....	1
2	SC-012-62	Mach. Screw 10-32 x 4 Slotted Fil. Hd.....	4
3	WL-003-20	Lockwasher #10 Light.....	4
4	00-065478-162-1	Stator Assy. (200/400 V., 60 Hz., 3 Ph.).....	1
5	00-065478-162-2	Stator Assy. (230/460 V., 60 Hz., 3 Ph.).....	1
6	00-065478-163-1	Stator Assy. (230/400 V., 50 Hz., 3 Ph.).....	1
7	SC-011-98	Mach. Screw 5/16-18 x 1-1/4 Slotted Fil. Hd.....	3
8	WL-003-43	Lockwasher 5/16 Light.....	3
9	SC-040-74	Cap Screw 5/16-18 x 2 Socket Fil. Hd.....	3
10	00-083715	Deflector - Grease.....	1
11	BB-020-15	Ball Bearing - SKF #6207Z.....	1
12	00-068968	Spacer - Bearing.....	1
13	00-275192	Block - Terminal.....	1
14	SC-012-36	Mach. Screw 10-24 x 3/4 Slotted Fil. Hd.....	2
15	RP-006-03	Roll Pin 1/8 x 3/4 Lg.....	4
16	WL-003-43	Lockwasher 5/16 Light.....	1
17	SC-011-98	Mach. Screw 5/16-18 x 1-1/4 Slotted Fil. Hd.....	1
18	00-015747-00302	Rotor Assy.....	1
19	BB-016-37	Ball Bearing - Fafnir #W204 PPC 1.....	1
20	RR-004-06	Retaining Ring.....	1
21	00-109070-00002	Key.....	1
22	SC-047-12	Set Screw 1/4-20 x 3/8 Socket Hdls., Knife Cup Pt.....	2
23	00-275183	Fan.....	1
24	00-275151	Bracket - Bearing.....	1

