



CATALOG OF REPLACEMENT PARTS

MODEL 4246 MIXER-GRINDERS



30153

STANDARD (5 HP./1 HP.)

4246S ML-134220

HEAVY DUTY (7.5 HP./1 HP.)

4246HD ML-134221

PRIOR MLS COVERED IN THIS
MANUAL

STANDARD (5 HP./1HP.)

4246S ML-038397

4246S ML-134216

HEAVY DUTY (7.5 HP./1 HP.)

4246HD ML-038401

4246HD ML-134214

Table of Contents

5 CONTROL BOX
7 CONTROL PANEL (ML-38397 AND ML-38401)
9 CONTROL PANEL (ML-134214, ML-134216, ML-134220, & ML-134221)
11 OPERATOR'S PANEL (ML-38397 AND ML-38401)
13 OPERATOR'S PANEL (ML-134214, ML-134216, ML-134220, & ML-134221)
15 HOPPER AND FRAME
19 GRIND TRANSMISSION (PREVIOUS CONSTRUCTION)
21 GRIND TRANSMISSION (CURRENT CONSTRUCTION)
23 GRIND CONVEYOR AND MIXING ARM/TRANSMISSION
25 GRIND MOTOR/DRIVE UNIT
27 MIX ARM MOTOR/VENTILATING UNIT
29 FOOT SWITCH
31 #32 GRINDER
33 SIDE FEED

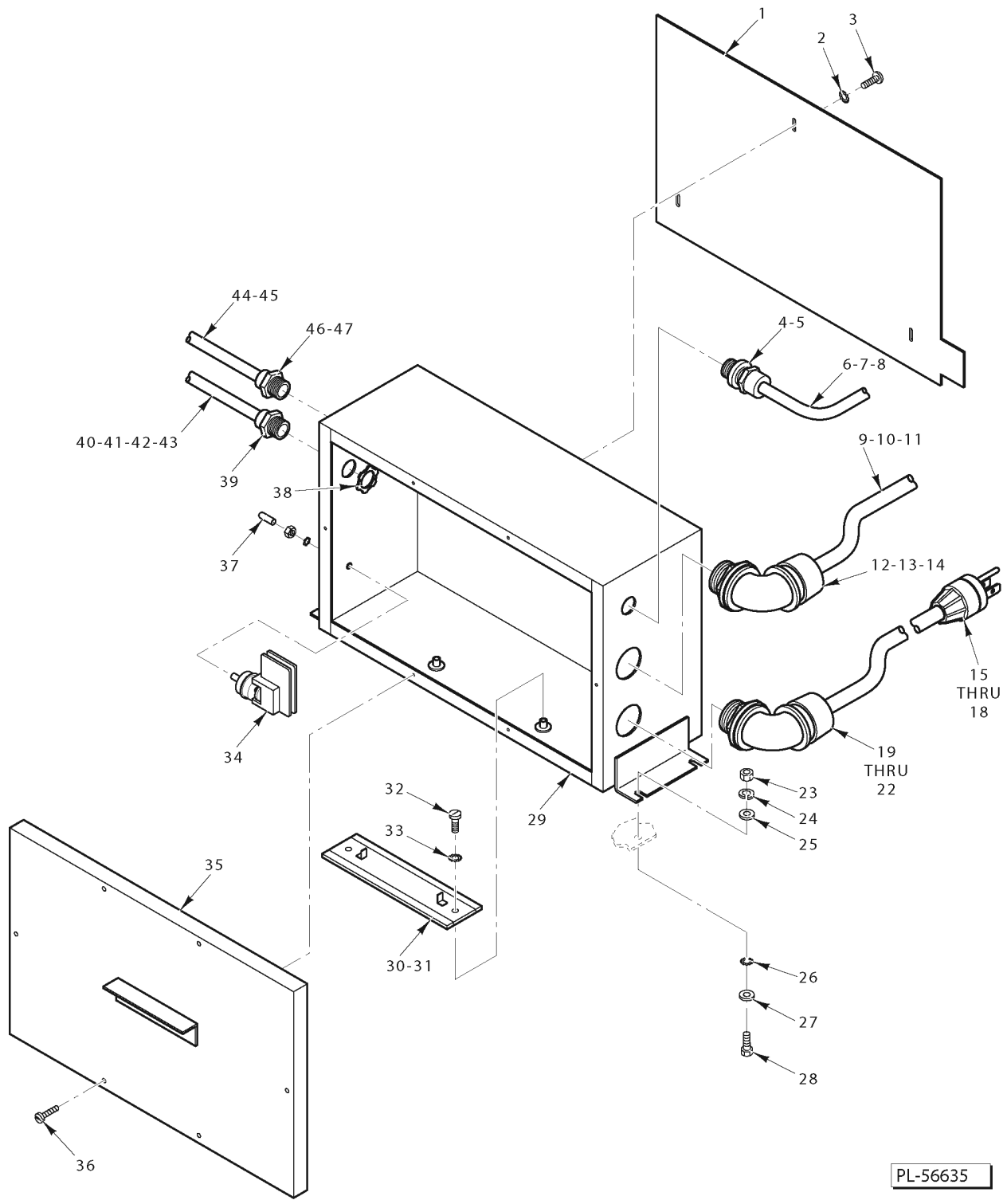

PL-56635

CONTROL BOX

CONTROL BOX

ILLUS.	PART NO.	NAME OF PART	AMT.
	PL-56635		
1	00-292671	Panel - Air Deflector (3 Ph.).....	1
2	WL-007-12	Lockwasher #10 External Shakeproof.....	3
3	SC-008-09	Mach. Screw 10-24 x 3/8 Rd. Hd.....	3
4	FE-022-84	Strain Relief.....	1
5	FE-024-88	Lock Nut Electrical 1/2.....	1
6	00-294853-00041	Cable - Mix Motor Control (ML-134214 & ML-134216).....	1
7	00-294853-00002	Cable - Mix Motor Control (3 Ph.) (ML-38397 & ML-38401).....	1
8	00-294853-00007	Cable - Mix Motor Control (1 Ph.) (ML-38397).....	1
9	00-294853-00052	Cable - Grind Motor Control (ML-134214 & ML-134216).....	1
10	00-294853-00001	Cable - Grind Motor Control (3 Ph.) (ML-38397 & ML-38401).....	1
11	00-294853-00008	Cable - Grind Motor Control (1 Ph.) (ML-38397).....	1
12	FE-023-41	Strain Relief.....	1
13	FE-006-50	Lock Nut Electrical 1.....	1
14	FE-008-12	Gasket - Electrical.....	1
15	00-478551-00001	Cord/Plug Assy. (208 V., 3 Ph.).....	1
16	00-478551-00002	Cord/Plug Assy. (240 V., 3 Ph.).....	1
17	00-117612-00016	Cord/Plug Assy. (480 V., 3 Ph.).....	1
18	00-294899-00001	Cord/Plug Assy. (208-240 V., 1 Ph.).....	1
19	FE-023-42	Strain Relief (208 V., 3 Ph.; 208-240 V., 1 Ph.).....	1
20	FE-023-41	Strain Relief (380-415 V., 50 Hz., 3 Ph.; 240-480 V., 60 Hz., 3 Ph.).....	1
21	FE-006-50	Lock Nut Electrical 1.....	1
22	FE-008-12	Gasket - Electrical.....	1
23	NS-015-01	Nut Hex 1/4-20.....	4
24	WL-006-17	Lockwasher 1/4 Helical.....	4
25	WS-017-06	Washer (SST).....	4
26	WS-017-06	Washer (SST).....	4
27	WL-007-16	Lockwasher 1/4 External Shakeproof.....	4
28	SC-041-01	Cap Screw 1/4-20 x 3/4 Hex Hd.....	4
29	00-186704-00001	Box Wldt. - Lower Control.....	1
30	00-478220-00001	Heater (208 V.) (ML-134214 & ML-134216).....	1
31	00-478220-00002	Heater (240 V.) (ML-134214).....	1
32	SC-018-11	Mach. Screw 10-24 x 3/8 Slotted Pan Hd.....	2
33	WL-007-12	Lockwasher #10 External.....	2
34	00-087711-213-1	Switch - Air Activated.....	1
35	00-186771	Lid & Gasket Assy.....	1
36	SD-036-39	Self-Tapping Screw 10-24 x 3/8 Truss Hd., Type TT.....	6
37	00-294855-00001	Cap.....	1
38	FE-024-88	Lock Nut Electrical 1/2.....	1
39	FE-022-84	Relief - Strain, Electrical.....	1
40	00-294853-00051	Cable - Interlock Switch (ML-134214 & ML-134216).....	1
41	00-294853-00003	Cable - Interlock Switch (3 Ph.) (ML-38397 & ML-38401).....	1
42	00-294853-00009	Cable - Interlock Switch (1 Ph.) (ML-38397).....	1
43	00-294853-00038	Cable - Interlock Switch (ML-134214 & ML-134216).....	1
44	00-294853-00004	Cable - Interlock Switch (3 Ph.) (ML-38397 & ML-38401).....	1
45	00-294853-00006	Cable - Interlock Switch (1 Ph.) (ML-38397).....	1
46	FE-022-84	Strain Relief.....	1
47	FE-024-88	Lock Nut Electrical 1/2.....	1

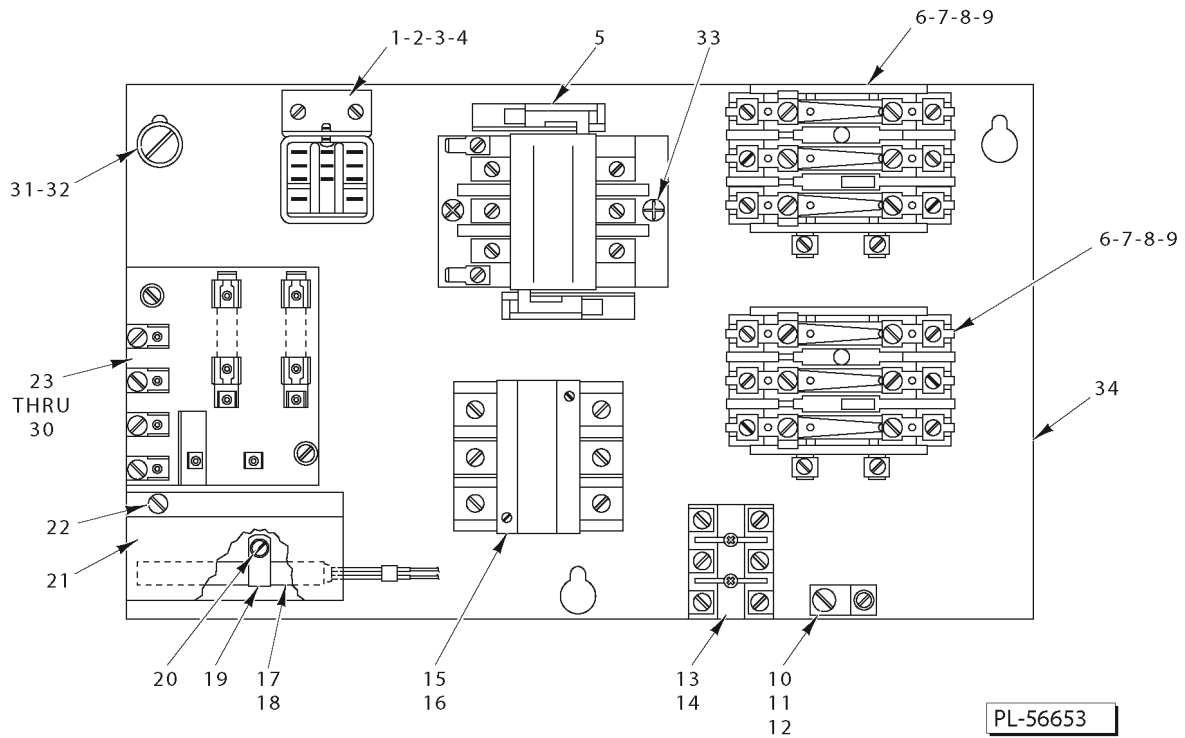

**CONTROL PANEL
(ML-38397 AND ML-38401)**

**CONTROL PANEL
(ML-38397 AND ML-38401)**

ILLUS. PL-56653	PART NO.	NAME OF PART	AMT.
1	00-087714-020-3	Relay - 3 P.D.T. (240VAC).....	1
2	00-087714-020-5	Relay 3 P.D.T. (208VAC).....	1
3	00-186748	Relay Mounting.....	1
4	SD-009-24	Self-Tapping Screw 6-32 x 3/8 Slotted Rd. Hd., Type F.....	4
5	00-087713-030-1	Contactator.....	1
6	SD-009-08	Self-Tapping Screw 8-32 x 3/8 Slotted Bndg. Hd., Type F.....	4
7	00-088196-009-1	Relay - Thermal Overload (3 Ph.).....	2
8	00-088196-006-1	Relay - Thermal Overload (1 Ph.) (W/Overload Protection).....	2
9		Heater Elements (Give Elec. Spec.).....	AR
10	00-118544-00001	Lug - Solderless.....	1
11	SD-009-12	Self-Tapping Screw 10-32 x 3/8 Slotted Rd. Hd., Type F.....	1
12	WL-007-12	Lockwasher #10 External Shakeproof.....	AR
13	00-294325-003-1	Block - Terminal.....	AR
14	SD-029-11	Self-Tapping Screw 6-32 x 1 Phil. Pan Hd., Type F.....	2
15	00-087713-071-1	Contactator (50A, 3 Pole, 2 Side Switches).....	1
16	SD-009-08	Self-Tapping Screw 8-32 x 3/8 Slotted Bndg. Hd., Type F.....	2
17	00-108202-00002	Heater.....	1
18	00-292708	Spacer - Heater.....	2
19	00-108199-00001	Clamp - Air Heater.....	1
20	SD-009-09	Self-Tapping Screw 8-32 x 1/2 Slotted Bndg. Hd., Type F.....	1
21	00-108101	Shield - Heater.....	1
22	SD-009-08	Self-Tapping Screw 8-32 x 3/8 Slotted Bndg. Hd., Type F.....	1
23	00-114707	Terminal & Mounting Board Assy. (480 V.).....	1
24	00-293555-00002	Transformer & Terminal Assy. (480 V., 60 Hz.).....	1
25	00-293555	Transformer & Terminal (480 V., 50 Hz.).....	1
26	FE-022-74	Fuse (Buss #FNQ-6/10).....	2
27	SC-019-33	Mach. Screw 8-32 x 1/2 Slotted Bind. Hd.....	2
28	NS-009-12	Nut 8-32 Hex.....	2
29	WL-007-07	Lockwasher #8 External Shakeproof.....	2
30	SD-009-08	Self-Tapping Screw 8-32 x 3/8 Slotted Bndg. Hd., Type F.....	2
31	SC-008-09	Mach. Screw 10-24 x 3/8 Slotted Rd. Hd.....	3
32	WL-007-12	Lockwasher #10 External Shakeproof.....	3
33	SD-009-08	Self-Tapping Screw 8-32 x 3/8 Slotted Bndg. Hd., Type F.....	2
34	00-186727	Plate - Control Mounting.....	1
	00-293215	Barrier - Control Box (480 V., 50 Hz.).....	1

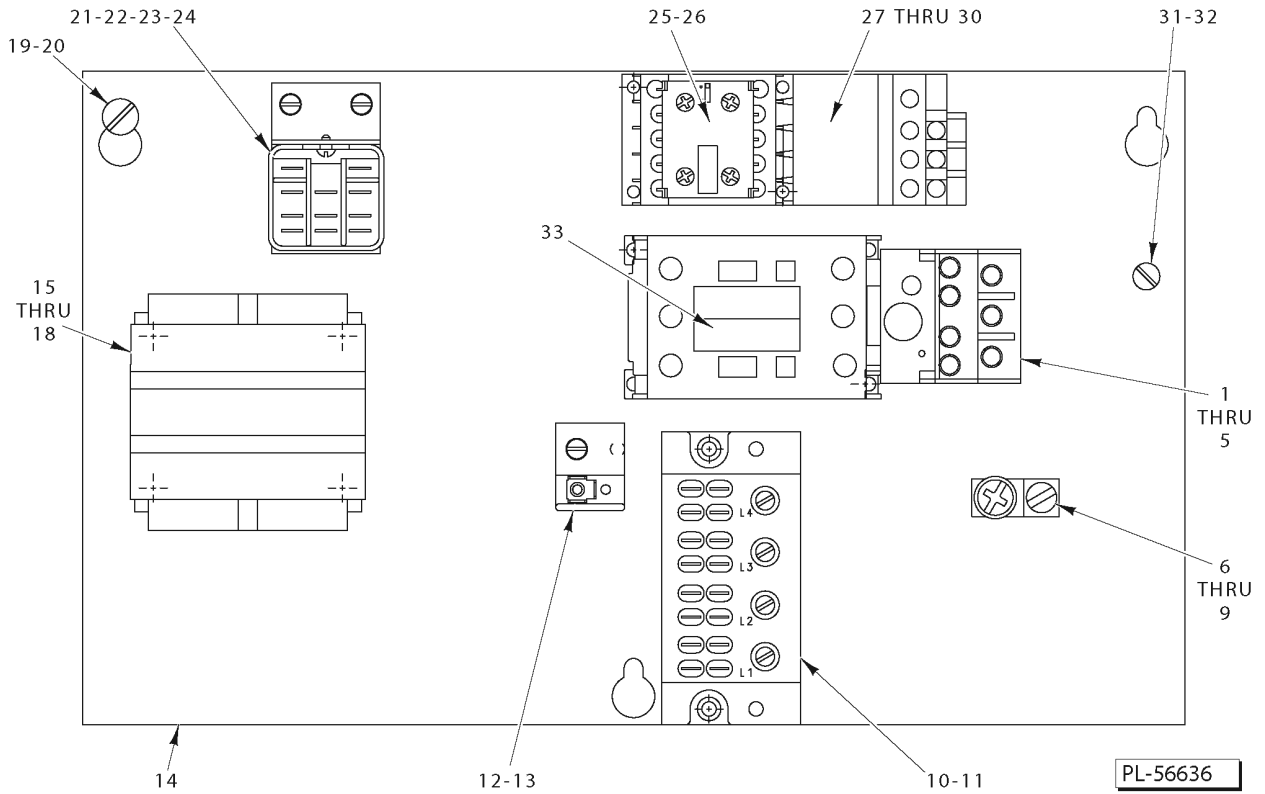

CONTROL PANEL
(ML-134214, ML-134216, ML-134220, & ML-134221)

CONTROL PANEL
(ML-134214, ML-134216, ML-134220, & ML-134221)

ILLUS. PL-56636	PART NO.	NAME OF PART	AMT.
1	00-087713-094-2	Contactora (208 V., 60 Hz., 3 Ph.).....	1
2	00-087713-094-3	Contactora (380-415 V., 50 Hz., 3 Ph.).....	1
3	00-088196-024-2	Relay - Overload (380-415 V., 50 Hz., 3 Ph.).....	1
4	00-088196-024-1	Relay - Overload (208 V., 60 Hz., 3 Ph.).....	1
5	SD-009-09	Self-Tapping Screw 8-32 x 1/2 Slotted Bndg. Hd.....	2
6	00-118544-00002	Lug.....	1
7	SC-114-29	Mach. Screw 1/4-20 x 3/8 Phil. Pan Hd.....	1
8	WL-007-14	NLA - Obsolete--Lockwasher 1/4 Medium.....	1
9	NS-046-38	Mach. Nut 1/4-20 Hex (SST).....	1
10	00-294325-00021	Block - Terminal (4 Pole).....	1
11	SD-038-03	Self-Tapping Screw 10-16 x 3/4 Slotted Truss Hd., Type B (SST).....	2
12	00-873203-00002	Block - Terminal (Modified).....	1
13	SD-009-24	Self-Tapping Screw 6-32 x 3/8 Slotted Rd. Hd., Type F.....	1
14	00-186727	Plate - Control Mounting.....	1
15	00-478962	Transformer & Fuse Block Assy. (380-415 V., 50 Hz., 3 Ph.).....	1
16	SD-009-08	Self-Tapping Screw 8-32 x 3/8 Slotted Bndg. Hd., Type F.....	4
17	FE-025-20	Fuse (0.2 Amp.) (600 V.) (380-415 V., 50 Hz., 3 Ph.).....	2
18	FE-025-58	Fuse (0.3 Amp.) (600 V.) (380-415 V., 50 Hz., 3 Ph.).....	1
19	SC-008-09	Mach. Screw 10-24 x 3/8 Slotted Rd. Hd.....	3
20	WL-007-12	Lockwasher #10 External.....	3
21	00-186748	Bracket - Relay Mounting.....	1
22	00-087714-020-3	Relay 3 P.D.T. (240VAC).....	1
23	00-087714-020-5	Relay 3 P.D.T. (208VAC).....	1
24	SD-009-24	Self-Tapping Screw 6-32 x 3/8 Slotted Rd. Hd., Type F.....	4
25	00-087711-00266	Switch - Auxiliary.....	1
26	SD-038-96	Self-Tapping Screw 6-32 x 1/2 Slotted Phil. Rd. Hd., Type F.....	2
27	00-087713-089-3	Contactora (208 V., 60 Hz., 3 Ph.).....	1
28	00-087713-089-2	Contactora (380-415 V., 50 Hz., 3 Ph.).....	1
29	00-088196-017-1	Relay - Overload (208 V., 60 Hz., 3 Ph.).....	1
30	00-088196-017-2	Relay - Overload (380-415 V., 50 Hz., 3 Ph.).....	1
31	SD-009-08	Self-Tapping Screw 8-32 x 3/8 Slotted Bndg. Hd., Type F.....	1
32	WL-007-12	Lockwasher #10 External.....	1
33	00-087711-268-1	Switch - Auxiliary.....	2

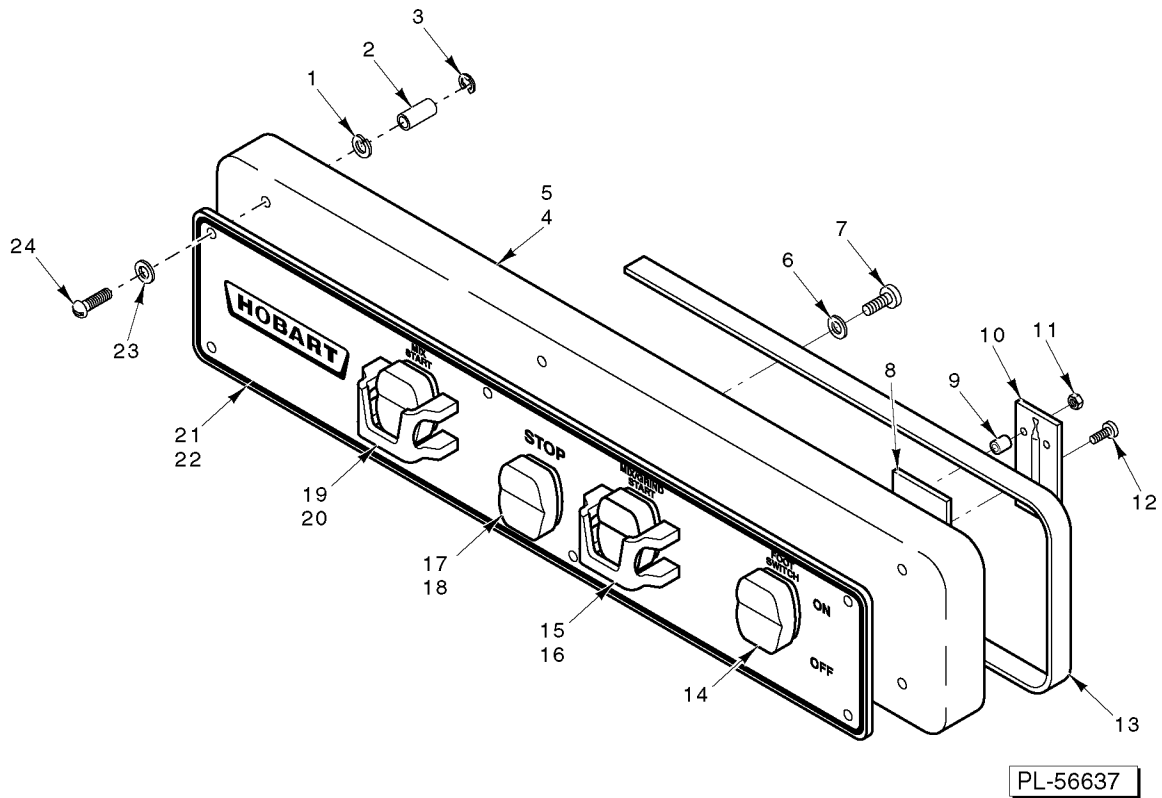

**OPERATOR'S PANEL
(ML-38397 AND ML-38401)**

**OPERATOR'S PANEL
(ML-38397 AND ML-38401)**

ILLUS.	PART NO.	NAME OF PART	AMT.
PL-56637			
1	WL-006-17	Lockwasher 1/4 Helical (SST).....	6
2	00-292917	Spacer - Switch Cover.....	6
3	00-067500-00058	O-Ring.....	6
4	00-186736-00001	Switch Cover Assy. (60 Hz.).....	1
5	00-292998-00001	Switch Cover Assy. (50 Hz.).....	1
6	WS-002-14	Washer.....	8
7	00-123109	Screw 6-32 x 3/8 Serrated Hd.....	8
8	00-124022	Insulator - Reed Mounting Board.....	4
9	00-118349-00003	Spacer - Control Panel.....	16
10	00-294854	Reed Mounting Board Assy.....	4
11	NS-031-01	Stop Nut - Special.....	8
12	SD-009-40	Self-Tapping Screw 6-32 x 3/4 Phil. Pan Hd., Type F.....	8
13	00-102825-00003	Gasket (Switch Cover).....	1
14	00-120872-00003	Switch - Select.....	1
15	00-186739	Guard - Switch.....	1
16	00-120872-00002	Switch - Start.....	1
17	00-120872-00004	Switch - Stop (60 Hz.) (Shown).....	1
18	00-087711-223-1	Switch - Push Pull (50 Hz.).....	1
19	00-186739	Guard - Switch.....	1
20	00-120872-00002	Switch - Start.....	1
21	00-186741	Panel - Trim (60 Hz.).....	1
22	00-292997	Panel - Trim (50 Hz.).....	1
23	WS-017-06	Washer (SST).....	6
24	SC-117-90	Mach. Screw 1/4-20 x 1 3/8 Slotted Rd. Hd. (SST).....	6

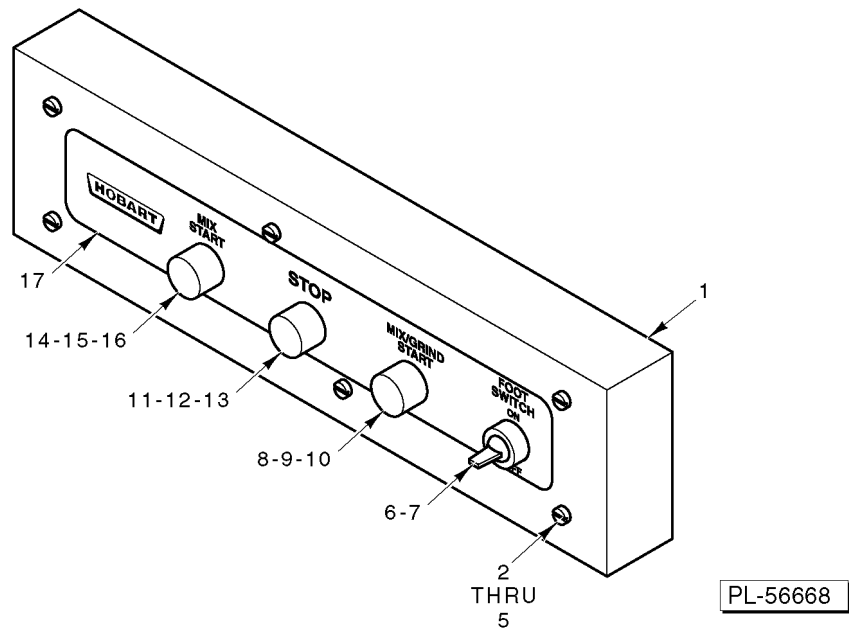

OPERATOR'S PANEL
(ML-134214, ML-134216, ML-134220, & ML-134221)

(ML-134214, ML-134216, ML-134220, & ML-134221)

OPERATOR'S PANEL
(ML-134214, ML-134216, ML-134220, & ML-134221)

ILLUS. PL-56668	PART NO.	NAME OF PART	AMT.
1	00-875455	Box - Operator Control Wldt.....	1
2	SC-128-44	Mach. Screw 1/4-20 x 2 1/4 Slotted Rd. Hd. (SST).....	6
3	WL-006-17	Lockwasher 1/4 Helical (SST).....	6
4	00-875537	Spacer.....	6
5	00-067500-00058	O-Ring.....	6
6	00-478752-00005	Switch - Select.....	1
7	00-087711-322-3	Block - Contact.....	1
8	00-478752-00003	Switch - Start.....	1
9	00-873427	Cap - Protective.....	1
10	00-087711-322-3	Block - Contact.....	1
11	00-478752-00008	Switch - Stop.....	1
12	00-873427-00002	Cap - Protective.....	1
13	00-087711-322-5	Block - Contact.....	1
14	00-478752-00003	Switch - Start.....	1
15	00-873427	Cap - Protective.....	1
16	00-087711-322-3	Block - Contact.....	1
17	00-875456	Trim - Panel.....	1
	00-522898	Tie - Cable.....	3
	SC-021-14	Mach. Screw 8-32 x 3/8 Slotted Rd. Hd. (SST).....	2
	WL-014-05	Lockwasher #8 External Shakeproof (SST).....	2
	SC-060-85	Mach. Screw 10-24 x 1 Slotted Rd. Hd.....	1
	00-478220-00001	Heater (208 V.).....	1
	00-478220-00002	Heater (240 V.).....	1
	SC-041-50	Cap Screw 1/4-20 x 1/2 Hex Hd. (SST) (Use W/478220).....	2
	WS-017-06	Washer (SST) (Use W/478220).....	2
	WL-010-01	Lockwasher #8 External Shakeproof (Use W/478220).....	2
	00-520228	Adhesive (Loctite #242, Blue) (Use W/478220).....	AR

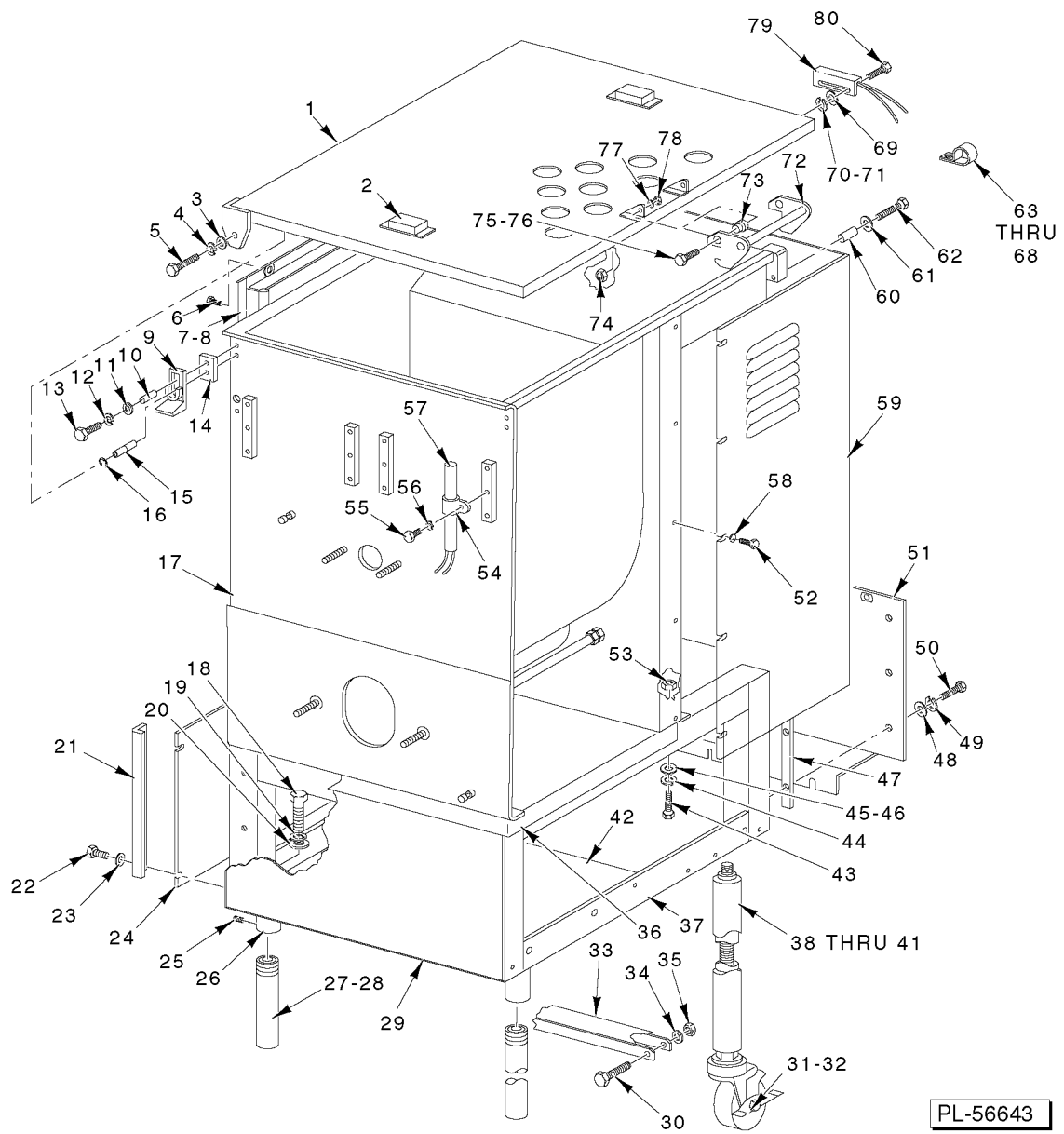

HOPPER AND FRAME

HOPPER AND FRAME

ILLUS.	PART NO.	NAME OF PART	AMT.
	PL-56643		
1	00-186742	Lid Assy. (Incls. Item 2).....	1
2	00-290160	Magnet.....	2
3	WS-008-48	Washer (SST).....	1
4	WL-006-23	Lockwasher 5/16 Helical (SST).....	1
5	SC-120-99	Cap Screw 5/16-18 x 2 1/4 Hex Hd.....	1
6	SC-053-05	Mach. Screw 10-24 x 3/8 Slotted Truss Hd. (SST).....	2
7	00-186753	Raceway & Gasket Assy. (Incls. Item 8).....	1
8	00-102825-00004	Gasket (Raceway).....	1
9	00-186654	Block - Cover Stop.....	1
10	00-186661-00001	Bushing - Pivot.....	1
11	WS-005-39	Washer (SST).....	1
12	WL-006-23	Lockwasher 5/16 Helical (SST).....	1
13	SC-120-32	Cap Screw 5/16-18 x 1 1/2 Hex Hd.....	1
14	00-186663	Spacer - Block.....	1
15	00-186625	Bushing - Pivot.....	1
16	RR-004-05	Retaining Ring.....	1
17	00-186683-00001	Hopper (Std.).....	1
18	SC-062-51	Cap Screw 5/8-11 x 1 1/2 Hex Hd.....	4
19	WL-004-20	Lockwasher 5/8 Helical.....	4
20	WS-030-07	Washer.....	4
21	00-186643	Cover - Corner Angle.....	4
22	SD-036-39	Self-Tapping Screw 10-24 x 3/8 Slotted Truss Hd., Type T (SST).....	8
23	WS-019-10	Washer (SST).....	8
24	00-186653	Cover - Side.....	2
25	SC-117-84	Set Screw 1/4-20 x 5/16 Hex Hdls., Cup Pt. (SST).....	8
26	00-186722	Leg.....	4
27	00-186669	Foot.....	4
28	00-186730	Leg Assy. (Std. W/Foot) (Incls. Items 18, 19, 20, 25, 26, & 27).....	4
29	00-186651	Cover - Front Panel.....	1
30	SC-097-16	Cap Screw 1/4-20 x 2 3/4 Hex Hd.....	2
31	00-186724	Caster - Rigid.....	AR
32	00-186725	Caster - Locking (Swivel).....	AR
33	00-292902	Bracket - Rigid Caster.....	1
34	WL-006-17	Lockwasher 1/4 Helical (SST).....	2
35	NS-015-01	Nut 1/4-20 Hex (SST).....	2
36	00-186652	Cover - Top.....	1
37	00-186620	Frame.....	1
38	00-292904	Adjustable Leg & Rigid Caster Assy. (Frt. Long Adj.) (17 1/2 Max) (Incls. Item 31).....	AR
39	00-292602	Adjustable Leg & Swivel Caster Assy. (Long Adj.) (17 1/2 Max) (Incls. Item 32).....	AR
40	00-292605	Adjustable Leg & Swivel Caster Assy. (Short Adj.) (12 1/4 Max) (Incls. Item 32).....	AR
41	00-186731	Leg Assy. (Std. W/Casters) (Incls. Items 18, 19, 20, 25, 26, & 32).....	4
42	00-186686-00001	Cover - Frame Bottom.....	1
43	SC-041-31	Cap Screw 3/8-16 x 1 1/4 Hex Hd. (SST).....	7
44	WL-006-28	Lockwasher 3/8 Helical (SST).....	7
45	WS-018-04	Washer (SST).....	7
46	WS-030-05	Washer (SST).....	7
47	00-186695	Plate - Nut.....	2
48	WS-017-08	Washer (SST).....	6
49	WL-006-23	Lockwasher 5/16 Helical (SST).....	6
50	SC-041-11	Cap Screw 5/16-18 x 3/4 Hex Hd. (SST).....	6
51	00-186650-00001	Cover - Lower Back.....	1
52	SD-036-39	Self-Tapping Screw 10-24 x 3/8 Slotted Truss Hd., Type TT (SST).....	AR
53	NS-015-13	Nut 3/8-16 Hex (SST).....	7
54	00-108199-00001	Clamp - Air Heater (ML-38397 & ML-38401 - Previous Construction).....	1
55	SC-009-56	Mach. Screw 8-32 x 3/8 Slotted Rd. Hd.....	1

HOPPER AND FRAME

ILLUS.	PART NO.	NAME OF PART	AMT.
PL-56643			
56	WL-010-01	Lockwasher #8 External Shakeproof.....	1
57	00-122345-00003	Heater Assy. (Ceramic) (ML-38397 & ML-38401 - Previous Construction).....	1
58	WS-019-10	Washer (SST).....	AR
59	00-186645-00001	Cover - Top Back.....	1
60	00-186661-00002	Bushing - Pivot.....	1
61	WL-006-23	Lockwasher 5/16 Helical (SST).....	1
62	SC-120-32	Cap Screw 5/16-18 x 1 1/2 Hex Hd.....	1
63	00-078752-00001	Clamp 11/16 (ML-134214 & ML-134216).....	1
64	00-078752-00002	Clamp 1/4 P (ML-134214).....	1
65	SC-062-50	Cap Screw 10-24 x 5/8 Hex Hd.....	1
66	WS-019-10	Washer (SST).....	1
67	WL-006-07	Lockwasher #10 Helical (SST).....	1
68	NS-009-22	Mach. Nut 10-24 Hex.....	1
69	WS-019-10	Washer (SST).....	2
70	NS-009-22	Mach. Nut 10-24 Hex.....	2
71	WL-006-07	Lockwasher #10 Helical (SST).....	2
72	00-186698	Handle Assy.....	1
73	00-289854	Pivot - Lid Stop.....	2
74	NS-010-16	Nut 10-24 Hex (Brass).....	2
75	SC-041-01	Cap Screw 1/4-20 x 3/4 Hex Hd. (SST).....	2
76	00-520228	Adhesive - Loctite.....	AR
77	WL-006-17	Lockwasher 1/4 Helical.....	2
78	NS-025-04	Crown Nut 1/4-20 (SST).....	2
79	00-087711-215-2	Switch - Reed (Interlock).....	1
80	SC-062-30	Cap Screw 10-24 x 5/8 Hex Hd.....	2
	00-295269	Leg Assy. (Set of 4, Std. W/Foot) (Packaged).....	1
	00-295271	Leg Assy. (Set of 4, Std. W/Caster) (Packaged).....	1
	00-295276	Leg Assy. (Set of 4, Short Adj.) (Packaged).....	1
	00-295282	Leg Assy. (Set of 4, Long Adj.) (Packaged).....	1

NOTES

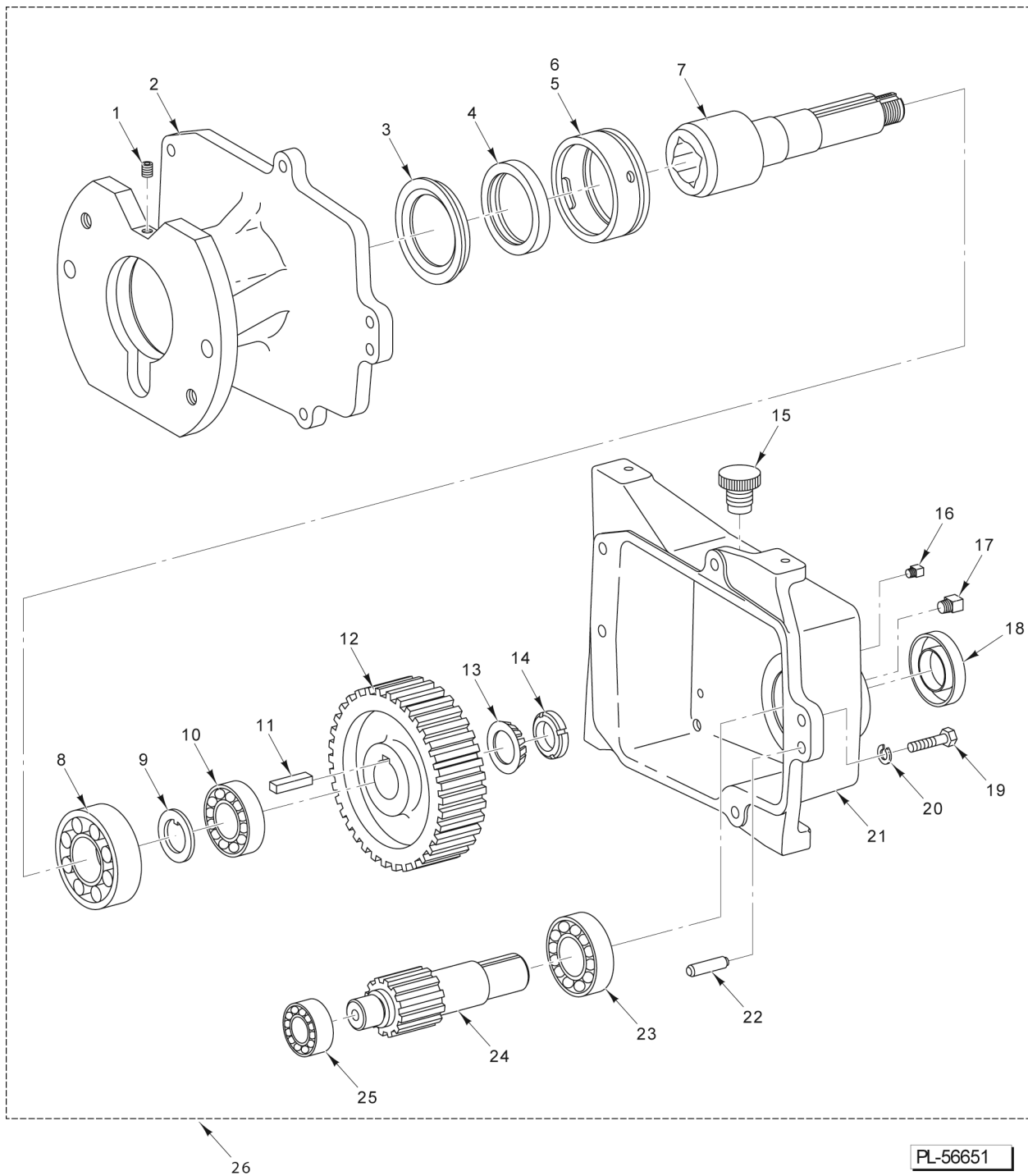

PL-56651

**GRIND TRANSMISSION
(PREVIOUS CONSTRUCTION)**

**GRIND TRANSMISSION
(PREVIOUS CONSTRUCTION)**

ILLUS. PL-56651	PART NO.	NAME OF PART	AMT.
1	SC-047-35	Set Screw 5/16-18 x 1/2 Hdls., Cup Pt.....	1
2	00-186627	Hub - Attachment.....	1
3	00-105196	Seal - Outer Conveyor.....	1
4	00-108591	Seal - Square Drive Shaft.....	1
5	00-186655	Retainer - Seal.....	1
6	00-067500-00052	O-Ring.....	1
7	00-186635	Shaft - Grind Worm Drive.....	1
8	BR-002-28	Roller Bearing - Cone & Cup Assy. (1.625 x 3.25).....	1
9	WL-017-07	Lockwasher - Bearing Lock Nut.....	1
10	BR-002-20	Roller Bearing - Cone & Cup Assy. (1.375 x 2.56).....	1
11	00-012430-00210	Key 5/16 x 5/16 x 1 3/8.....	1
12	00-186642	Gear (57T).....	1
13	NS-034-07	Lock Nut - Bearing.....	1
14	WS-031-36	Washer.....	1
15	00-108963-00002	Plug - Oil Fill.....	1
16	FP-028-42	Plug - Pipe 1/8.....	1
17	FP-028-38	Plug - Pipe 3/8.....	1
18	00-186657	Seal - Oil.....	1
19	SC-062-22	Cap Screw 3/8-16 x 1-1/4 Hex Hd.....	5
20	WL-006-28	Lockwasher 3/8 Helical (SST).....	5
21	00-186626	Case - Gear.....	1
22	00-508199	Dowel Pin.....	2
23	BB-007-21	Ball Bearing SKF 6207BE.....	1
24	00-186636	Shaft - Pinion (18T).....	1
25	BB-018-33	Ball Bearing - Fafnir #205K.....	1
26	00-186712	Transmission Assy. (Includes Items 1 through 25).....	1

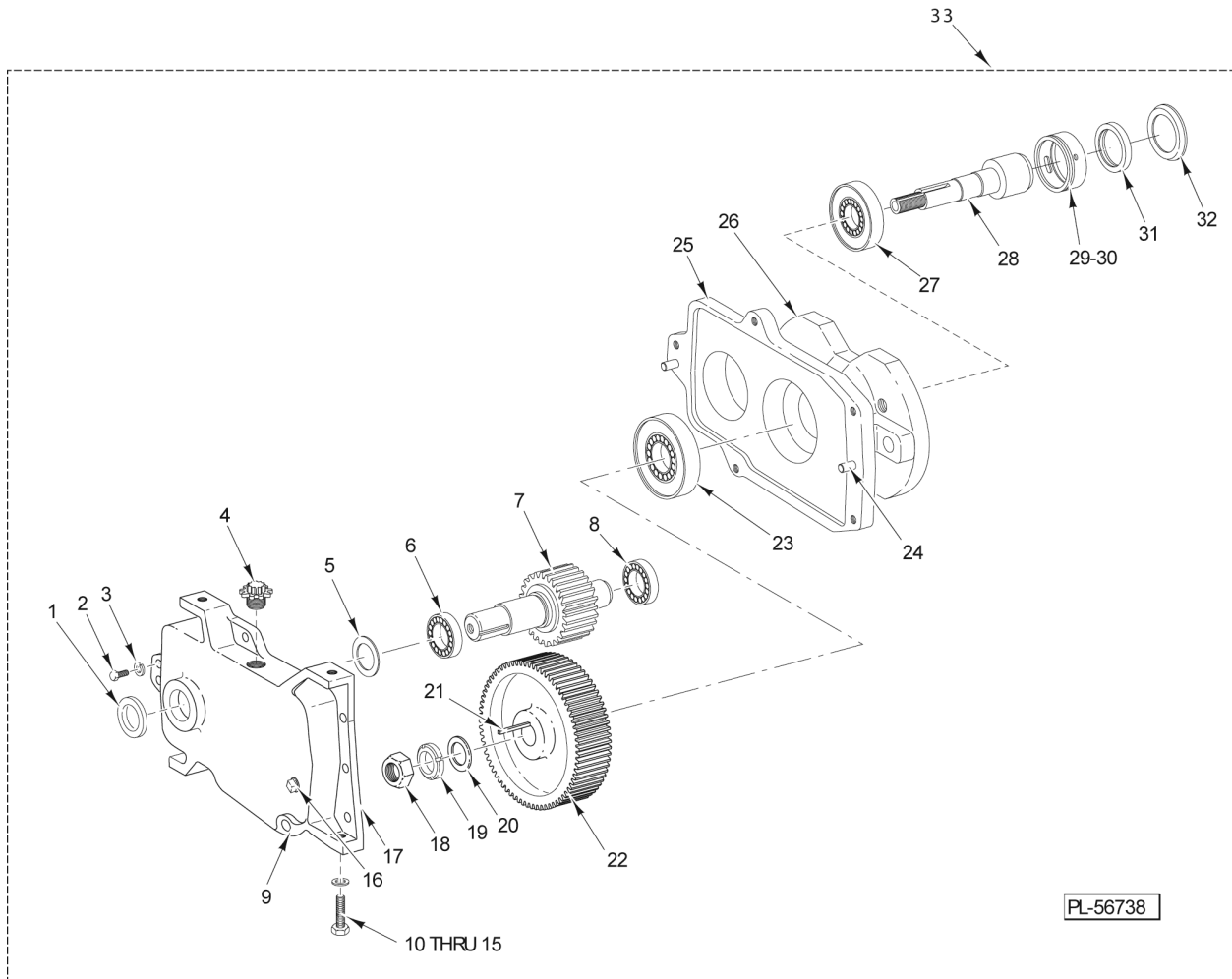

**GRIND TRANSMISSION
(CURRENT CONSTRUCTION)**

GRIND TRANSMISSION (CURRENT CONSTRUCTION)

ILLUS. PL-56738	PART NO.	NAME OF PART	AMT.
1	00-186657	Seal - Oil.....	1
2	SC-062-22	Cap Screw 3/8-16 x 1-1/4 Hex Hd.....	5
3	WL-006-28	Lockwasher 3/8 Helical.....	5
4	00-108963-00002	Plug - Oil Fill.....	1
5	SL-003-11	Spring - Loading N.D. 72.....	1
6	BB-007-21	Ball Bearing - N.D. 3207.....	1
7	00-477940	Shaft - Pinion (18T).....	1
8	BB-018-33	Ball Bearing Fahnr #205KF.....	1
9	FP-028-38	Plug - Pipe 3/8.....	1
10	SC-062-22	Cap Screw 3/8-16 x 1-1/4 Hex Hd.....	2
11	WL-006-28	Lockwasher 3/8 Helical.....	2
12	00-186646-00001	Shim (0.120 Thk.).....	AR
13	00-186646-00002	Shim (0.060 Thk.).....	AR
14	00-186646-00003	Shim (0.030 Thk.).....	AR
15	00-186646-00004	Shim (0.018 Thk.).....	AR
16	FP-028-42	Plug - Pipe 1/8.....	1
17	00-873483-00002	Case - Gear.....	1
18	NS-034-07	Lock Nut N.D. #N-06.....	1
19	WS-031-36	Washer.....	1
20	WL-017-07	Lockwasher - Bearing Lock Nut.....	1
21	00-012430-00215	Key 5/16 x 5/16 x 1 1/2.....	1
22	00-477939	Gear (57T).....	1
23	BR-002-20	Bearing Assy. - Roller 1.37 x 2.56.....	1
24	00-508199	Pin Dowel (Mach.).....	2
25	00-477946-00002	Hub - Attachment.....	1
26	SC-047-35	Set Screw 5/16-18 x 1/2 Hdls., Cup Pt.....	1
27	BR-002-28	Bearing Assy. - Roller 1.62 x 3.25.....	1
28	00-186635	Shaft - Grind Worm Drive.....	1
29	00-186655	Retainer - Seal.....	1
30	00-067500-00052	O-Ring (Rubber).....	1
31	00-108591	Seal - Sq. Drive Shaft.....	1
32	00-105196	Seal - Outer Conveyor.....	1
33	00-875585	Transmission Assy. (Includes Items 1 through 32).....	1

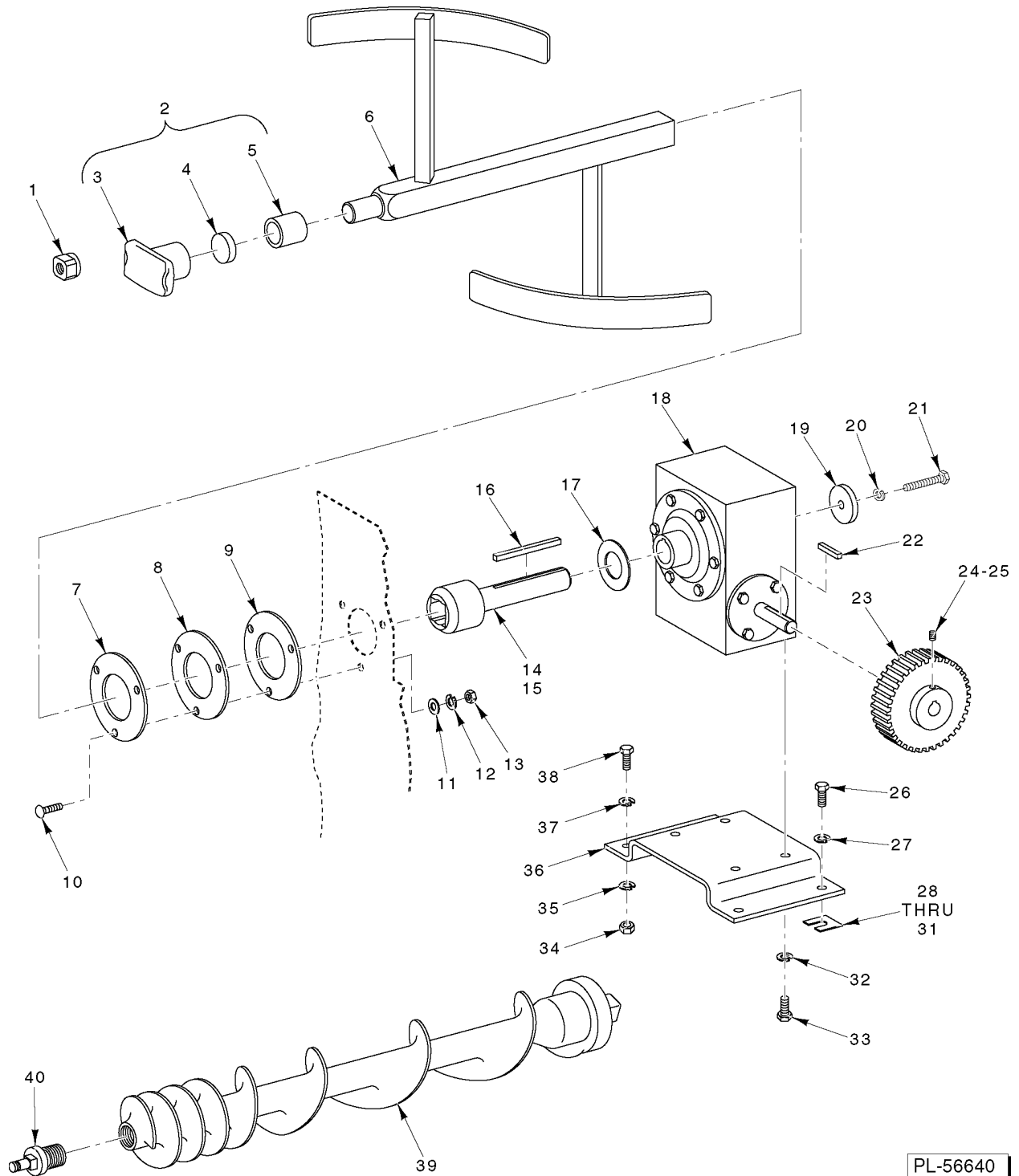

GRIND CONVEYOR AND MIXING ARM/TRANSMISSION

GRIND CONVEYOR AND MIXING ARM/TRANSMISSION

ILLUS. PL-56640	PART NO.	NAME OF PART	AMT.
1	NS-048-57	Nut 5/8-11 Flanged.....	2
2	00-186728	Pilot Bushing Assy.....	1
3	00-186629	Bushing.....	1
4	00-186660	Washer - Thrust.....	1
5	00-186659	Bearing - Pilot Bushing.....	1
6	00-186718	Arm - Mixing.....	1
7	00-186649	Washer - Backing.....	1
8	00-186656	Seal - Mixing Arm Drive Shaft.....	1
9	00-186649	Washer - Backing.....	1
10	SC-094-20	Bolt 5/16-18 x 1 Sq. Nk. Rd.....	3
11	WS-005-39	Washer (SST).....	3
12	WL-006-23	Lockwasher 5/16 Helical (SST).....	3
13	NS-015-11	Nut 5/16-18 Hex (SST).....	3
14	00-875578	Shaft - Mixing Arm Square Drive.....	1
15	00-186706	Plug.....	1
16	00-012430-00196	Key 1/4 x 1/4 x 4-3/4.....	1
17	00-186702	Washer - Shim.....	AR
18	00-186696	Gear Reducer.....	1
19	00-186703	Washer.....	1
20	WL-006-28	Lockwasher 3/8 Helical (SST).....	4
21	SC-062-22	Cap Screw 3/8-16 x 1-1/4 Hex Hd.....	1
22	00-012430-00067	Key 3/16 x 3/16 x 1 1/2.....	1
23	00-186623-00001	Pulley - Driven (40T).....	1
24	SC-088-46	Set Screw 10-24 x 3/8 Soc. Hdls., Cup Pt.....	2
25	00-520228	Adhesive - Loctite.....	AR
26	SC-062-22	Cap Screw 3/8-16 x 1-1/4 Hex Hd.....	2
27	WL-006-28	Lockwasher 3/8 Helical (SST).....	2
28	00-186646-00001	Shim (0.120 In.).....	AR
29	00-186646-00002	Shim (0.060 In.).....	AR
30	00-186646-00003	Shim (0.030 In.).....	AR
31	00-186646-00004	Shim (0.018 In.).....	AR
32	WL-006-28	Lockwasher 3/8 Helical (SST).....	4
33	SC-118-12	Cap Screw 3/8-16 x 3/4 Hex Hd.....	4
34	NS-015-13	Nut 3/8-16 Hex (SST).....	2
35	WL-006-28	Lockwasher 3/8 Helical (SST).....	2
36	00-293444	Plate - Mounting.....	1
37	WS-026-02	Washer (SST).....	2
38	SC-066-22	Cap Screw 3/8-16 x 1 1/4 Hex Hd.....	2
39	00-186641	Conveyor Screw Assy. (Incls. Item 40).....	1
40	00-110576	Plate - Stud.....	1

25 00-186713 Belt - Flexa - Gear
PARTS NOT ILLUSTRATED

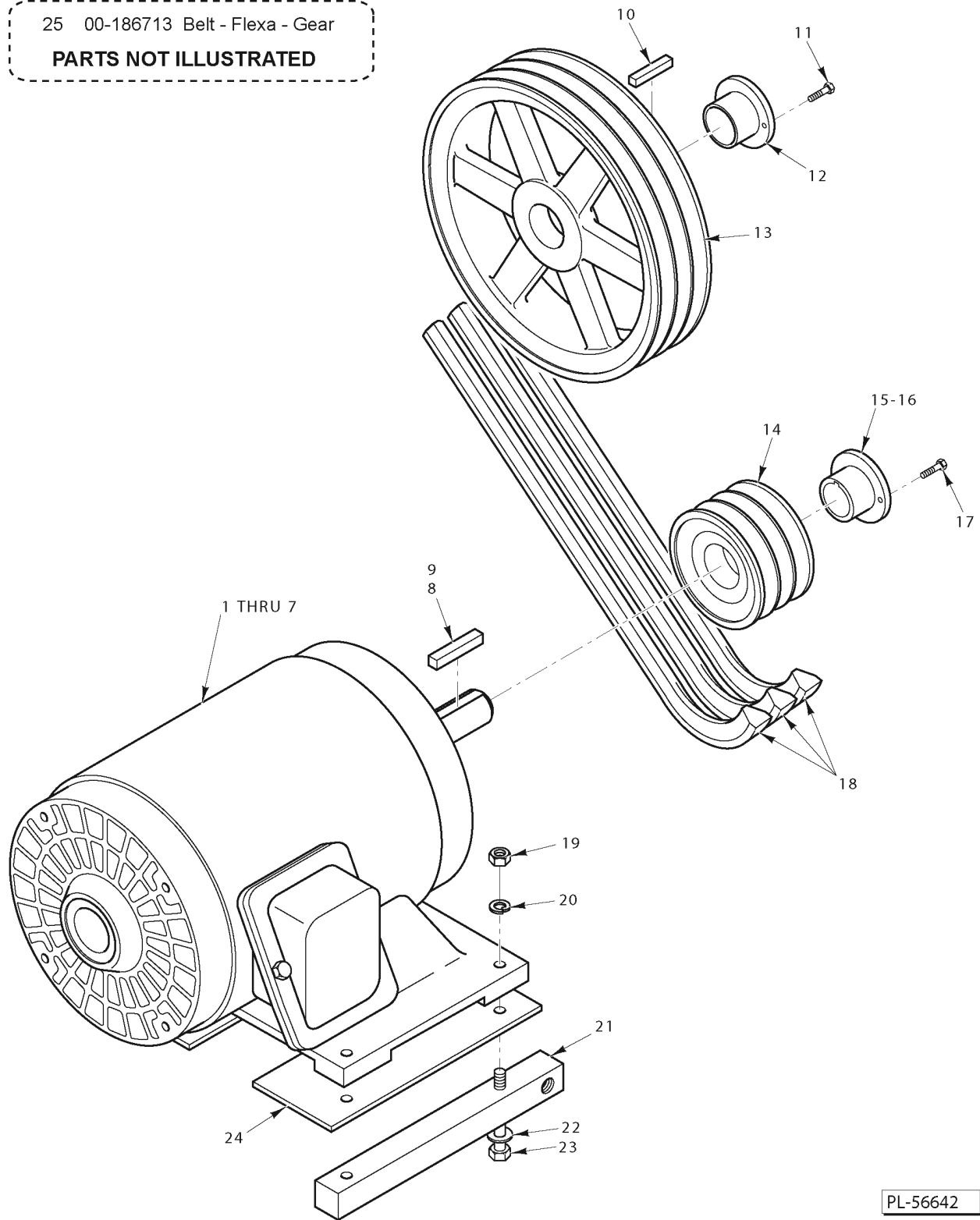

PL-56642

GRIND MOTOR/DRIVE UNIT

GRIND MOTOR/DRIVE UNIT

ILLUS.	PART NO.	NAME OF PART	AMT.
PL-56642			
1	00-435696-00003	Motor Assy. - Drive (208 V., 60 Hz., 3 Ph., 5 Hp.).....	1
2	00-435696-00004	Motor Assy. - Drive (240/480 V., 60 Hz., 3 Ph., 5 Hp.).....	1
3	00-435697-00003	Motor Assy. - Drive (208 V., 60 Hz., 3 Ph., 7.5 Hp.).....	1
4	00-435697-00004	NLA - Obsolete--Motor - Grind (240/480 V., 60 Hz., 3 Ph., 7-1/2 Hp.).....	1
5	00-293210-00001	Motor Assy. - Drive (240/480 V., 50 Hz., 3 Ph., 7.5 Hp.).....	1
6	00-435698-00002	Motor Assy. - Drive (208-240 V., 60 Hz., 1 Ph., 5 Hp.).....	1
7	FE-023-47	Strain Relief - Electrical (1 In.).....	1
8	00-012430-00106	Key 3/16 x 5/16 1 1/4.....	1
9	00-012430-00163	Key 1/4 x 1/4 x 1-3/4.....	1
10	00-012430-00178	Key 1/4 x 1/4 x 1-1/2.....	1
11	SC-118-19	Cap Screw 1/4-20 x 3/4 Hex Hd.....	2
12	00-479615-00002	Hub.....	1
13	00-479615-00001	Pulley - Transmission.....	1
14	00-479613-00001	Pulley - Grind Motor.....	1
15	00-479613-00002	Hub (7.5 Hp.).....	1
16	00-479613-00003	Hub (5 Hp.).....	1
17	SC-118-19	Cap Screw 1/4-20 x 3/4 Hex Hd.....	2
18	BV-013-37	V - Belt (BX Cross Section).....	3
19	NS-015-13	Nut 3/8-16 Hex (SST).....	4
20	WL-006-28	Lockwasher 3/8 Helical (SST).....	4
21	00-186694	Support - Motor Mount.....	2
22	WS-018-04	Washer (SST).....	4
23	SC-097-31	Cap Screw 3/8-16 x 2 1/2 Hex Hd.....	4
24	00-186682	Cover - Motor Plate.....	1
25	00-186713	Belt - Flexa - Gear.....	1
	00-875243	Conversion Kit - Belt/Pulley Assy.(60Hz.,7.5 Hp.)(Incls. Items 12-15,18,&FP-028-38)	1
	00-875244	Conversion Kit - Belt/Pulley Assy.(60Hz.,5Hp.)(Incls.Items 12,13,14,16,18,&FP-028-38).....	1
	00-875245	Conversion Kit - Belt/Pulley Assy.(50Hz.,7.5Hp.)(Incls. Items 12-15,18,&FP-028-38)	1

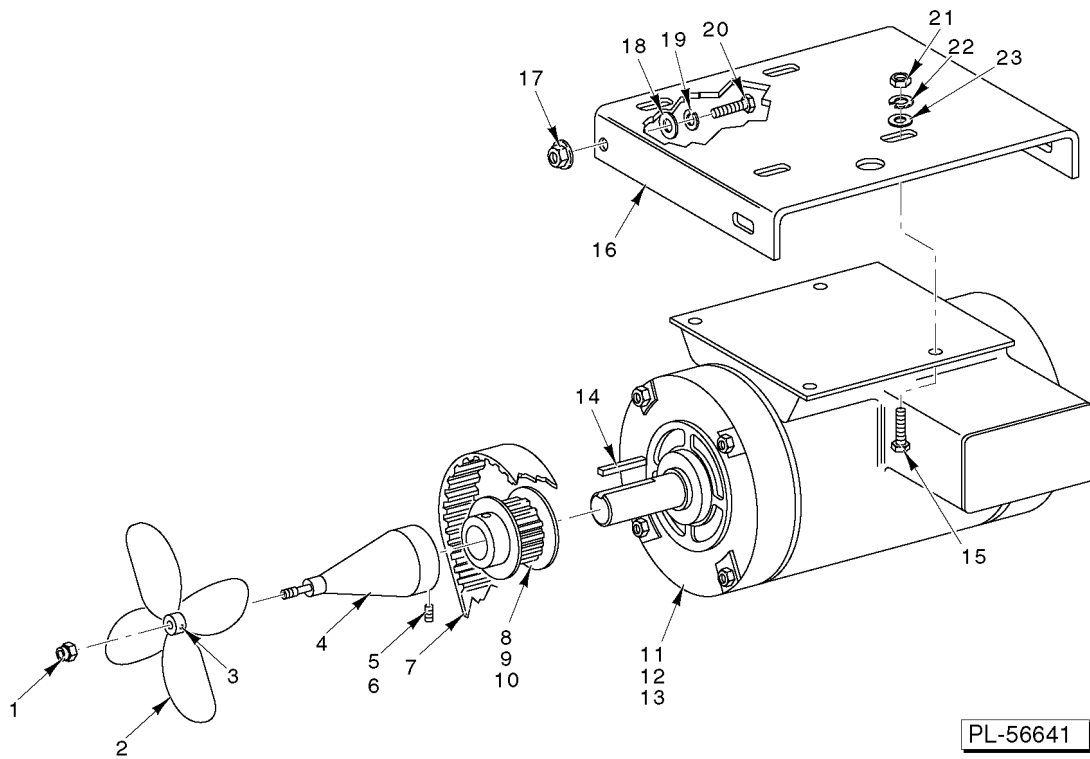

PL-56641

MIX ARM MOTOR/VENTILATING UNIT

MIX ARM MOTOR/VENTILATING UNIT

ILLUS.	PART NO.	NAME OF PART	AMT.
PL-56641			
1	NS-031-20	Stop Nut 1/4-20 Hex.....	1
2	00-186786	Blade - Fan.....	1
3	SC-075-30	Set Screw 8-32 x 3/16 Hdls., Cup Pt.....	1
4	00-274696	Shaft - Fan Adapter.....	1
5	SC-117-84	Set Screw 1/4-20 x 5/16 Hex Hdls., Cup Pt. (SST).....	1
6	00-520228	Adhesive - Loctite.....	AR
7	00-186714	Belt - Flexa-Gear.....	1
8	00-186622	Pulley - Driver (16T) (60 Hz.).....	1
9	00-292996	Pulley - Driver (19T) (50 Hz.).....	1
10	SC-075-30	Set Screw 8-32 x 3/16 Hex Hdls., Cup Pt.....	1
11	00-435805-00002	Motor Assy. (208-240/480 V., 60 Hz., 3 Ph., 1 Hp.).....	1
12	00-435806-00002	Motor Assy. (208-240 V., 60 Hz., 1 Ph., 1 Hp.).....	1
13	00-293209-00001	Motor Assy. (240/480 V., 50 Hz., 3 Ph., 1 Hp.).....	1
14	00-012430-00091	Key 3/16 x 3/16 x 1 3/8.....	1
15	SC-037-85	Cap Screw 5/16-18 x 1 Hex Hd.....	4
16	00-186689	Bracket - Upper Motor Mounting.....	1
17	NS-038-10	Lock Nut 3/8-16 Hex.....	4
18	WS-018-04	Washer (SST).....	4
19	WL-006-28	Lockwasher 3/8 Helical.....	4
20	SC-041-31	Cap Screw 3/8-16 x 1-1/4 Hex Hd. (SST).....	4
21	NS-013-14	Nut 5/16-18 Hex.....	4
22	WL-006-23	Lockwasher 5/16 Helical (SST).....	4
23	WS-005-39	Washer (SST).....	8

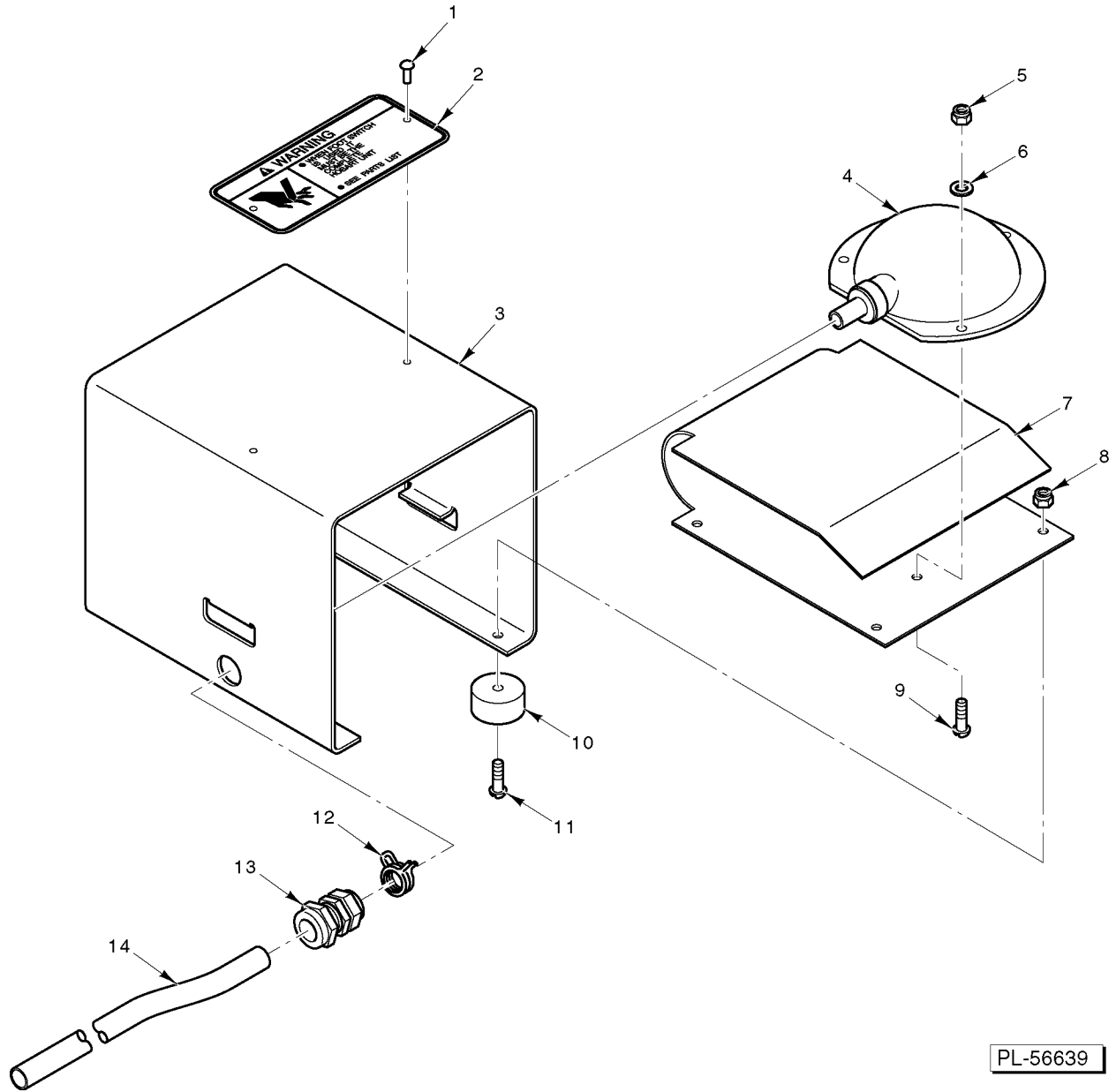

FOOT SWITCH

FOOT SWITCH

ILLUS.	PART NO.	NAME OF PART	AMT.
1	00-123702	Stud - Weld.....	2
2	00-438131-00083	Plate - Warning.....	1
3	00-873544	Cover - Foot Switch.....	1
4	00-087711-214-1	Switch - Actuator.....	1
5	NS-031-08	Stop Nut Special 8-32 (SST).....	3
6	WS-023-44	Washer (SST).....	3
7	00-873543	Switch - Foot Pedal.....	1
8	NS-031-08	Stop Nut Special 8-32 (SST).....	4
9	SC-021-15	Mach. Screw 8-32 x 1/2 Slotted Rd. Hd. (SST).....	3
10	00-019105-00002	Bumper.....	4
11	SC-021-89	Mach. Screw 8-32 x 5/8 Slotted Rd. Hd. (SST).....	4
12	00-115747-00008	Clamp - Hose.....	2
13	FE-024-10	Strain Relief.....	1
14	00-875712	Tubing - Assembly w/Clamp (66 In.) Tubing - Air.....	1
	00-873545	Foot Switch Assy. (Incls. Items 1 thru 14).....	1

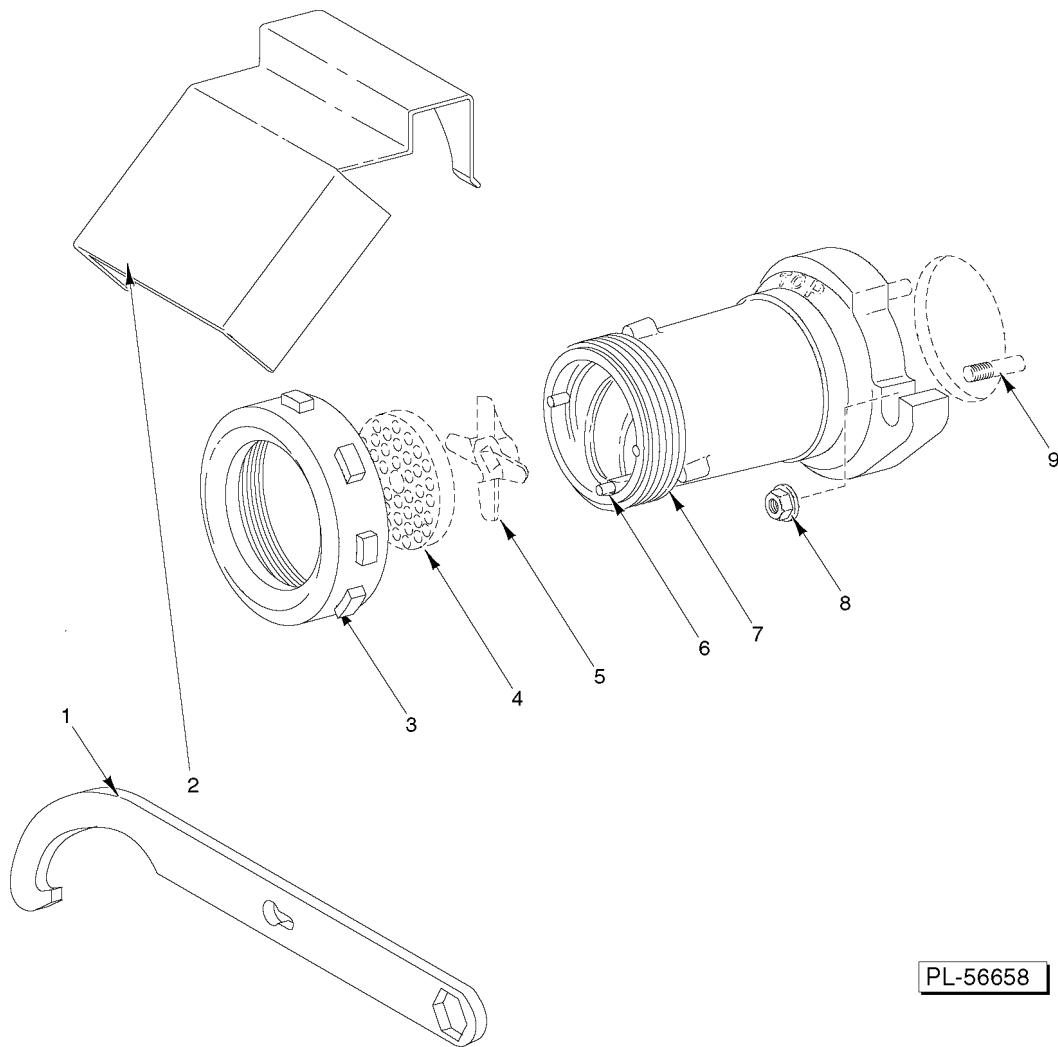

PL-56658

#32 GRINDER

#32 GRINDER

ILLUS.	PART NO.	NAME OF PART	AMT.
PL-56658			
1	00-873570	Wrench - Cylinder.....	1
2	00-875250	Meat Deflector (Packaged).....	1
3	00-873697	Ring - Adjusting.....	3
6	00-105806	Pin - Plate.....	3
7	00-873720-00002	Cylinder #32 (Mach. SST).....	1
8	NS-048-57	Nut 5/8-11 Flanged Hex.....	2
9	00-118266	Stud.....	2

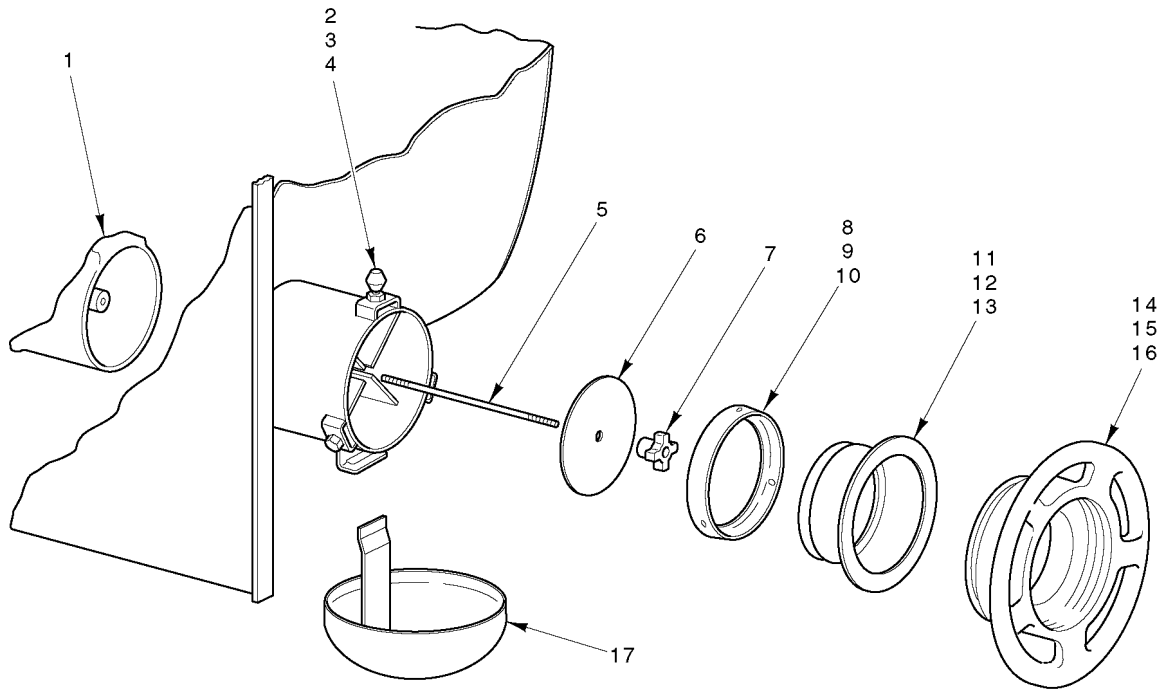

PL-56650

SIDE FEED

SIDE FEED

ILLUS.	PART NO.	NAME OF PART	AMT.
PL-56650			
1	00-186754	Plug - Side Feed Hopper.....	1
2	00-108197-00006	Thumb Screw (2 In. Lg.).....	3
3	00-108197-00007	Thumb Screw (1-7/16 In. Lg.).....	3
4	00-108197-00008	Thumb Screw (2-9/16 In. Lg.).....	3
5	00-186755	Rod - Tie.....	1
6	00-107237	Cap - Hopper Feed.....	1
7	00-292420	Knob Assy.....	1
8	00-086111	Retainer - Adapter (#56 Size).....	1
9	00-082154	Retainer - Adapter (#52 Size).....	1
10	00-082153	Retainer - Adapter (#32 Size).....	1
11	00-086110	Adapter (#56 Size).....	1
12	00-082149	Adapter (#52 Size).....	1
13	00-082146	Adapter (#32 Size).....	1
14	00-080879-00002	Ring - Adapter Adj. (For 4352, 4046, & 4146 Stub Thd.) (Packaged).....	1
15	00-081374-00002	Ring - Adapter Adj. (For 52-46 "Stub Thd.") (Packaged).....	1
16	00-109738-00001	Ring - Adapter Adj. (For 4056, 4156, & 4356 Stub Thd.) (Packaged).....	1
17	00-295109	Dripping Cup Assy.....	1
	00-186885	Hopper Feed Plug Assy. (Incls. Items 1 & 5).....	1
	00-109369-00002	Adapter Assy. (#56 Size) (For Non-Hobart Choppers) (Incls. Items 3, 8, & 11).....	1
	00-109370-00002	Adapter Assy. (#52 Size) (For Non-Hobart Choppers) (Incls. Items 2, 9, & 12).....	1
	00-109371-00002	NLA - Obsolete--Adapter Assy. (#32 Size) (For Non-Hobart Choppers) (Incls. Items 4, 10, & 13).....	1

