

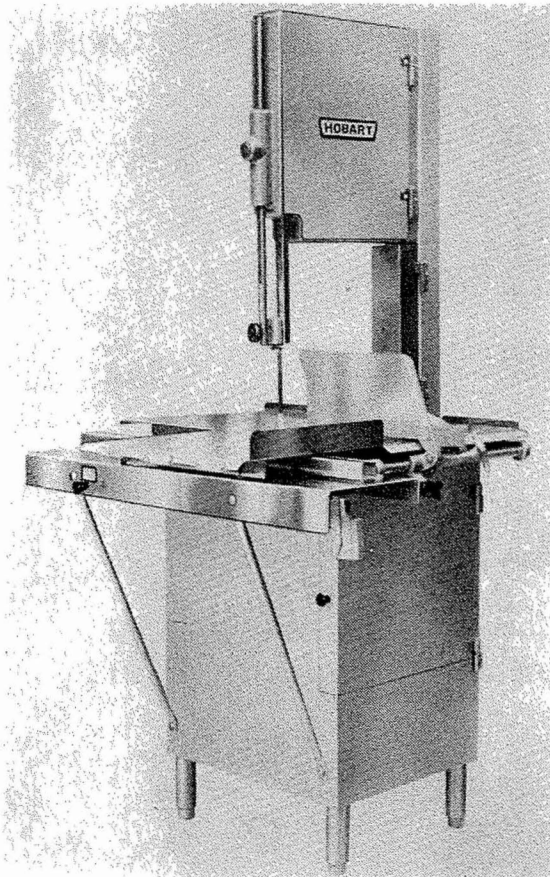

INSTRUCTION MANUAL

... with Replacement Parts



MODELS 5614 SERIES MEAT SAWS

ML-19551	5614	(PAINTED)
ML-19553	5614D	(SST)
ML-19554	5614-HS	(PAINTED)
ML-19556	5614D-HS	(SST)

INSTALLATION DIAGRAM

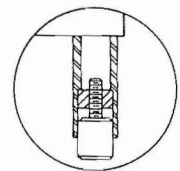

ENLARGED VIEW OF LEG
SHOWING ADJUSTING FOOT

ELECTRICAL AND GROUNDING CONNECTIONS MUST COMPLY WITH THE APPLICABLE PORTIONS OF THE NATIONAL ELECTRICAL CODE AND/OR OTHER LOCAL ELECTRICAL CODES. CONNECTION OF CONDUIT TO BASE MUST BE MADE USING A WATERPROOF FITTING OF PROPER SIZE AND DESIGN.

1-3/32" DIA. HOLE LOCATED AS SHOWN IN BACK OF BASE FOR CABLE OUTLET.

* THESE DIMENSIONS MAY INCREASE AS MUCH AS 1/2" DEPENDING ON LEG ADJUSTMENT.

MACHINE IS PARTIALLY DISASSEMBLED FOR SHIPMENT. CRATED MACHINE WILL PASS THRU A 32-1/2" OPENING.

NET WEIGHT OF MACHINE
DOMESTIC SHIPPING WT.
EXPORT SHIPPING WT.

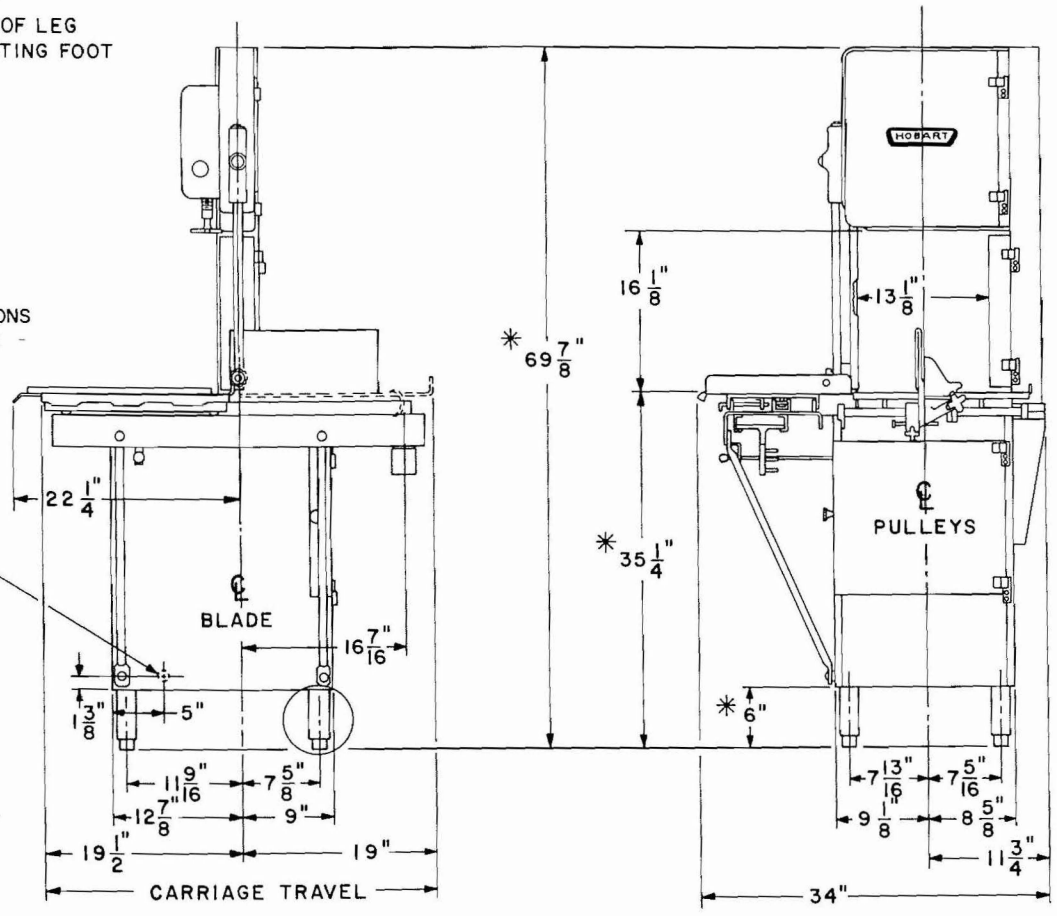

PL-18047

D-120148

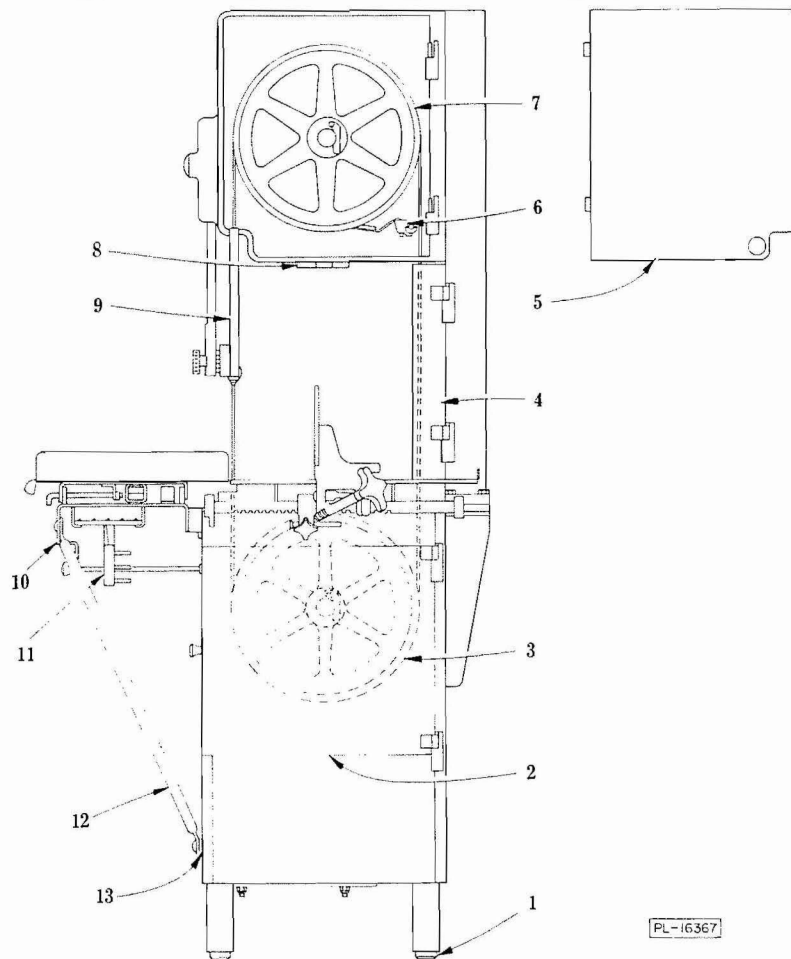

Fig. 1

Installation, Operation and Care of MODELS 5614 SERIES MEAT SAWS

A. UNPACKING:

A.1 Remove the shipping box that covers the saw. The following parts (which were disassembled for shipping purposes) should now be unpacked: table assembly, carriage assembly, carriage support assembly, saw blade, front wiper assembly, rear wiper assembly, switch push rod and feet. The pusher plate is packed in the scrap pan in the base compartment. Remove the four retaining bolts from the underside of the skid.

B. SETTING UP (Installation):

B.1 Place the machine in its operating location and reassemble the feet (1, Fig. 1). Place a spirit level on top of the base unit and level the base, side to side and front to back, by adjusting the feet. Lock feet in place, using set screws furnished.

B.2 Disassemble the fourteen retaining screws and remove the motor access panel on the left hand side of machine. Bolt the carriage support (10, Fig. 1) to the base. Next assemble the two support braces (12, Fig. 1). Spacers (13, Fig. 1) are used on the lower carriage bolts, and nuts (with lock washers) are assembled on the inside of the base.

B.3 Give the tension adjustment hand wheel (8, Fig. 1) a few turns to the left to lower the upper blade pulley (7, Fig. 1). Open the head door (5, Fig. 1). Remove the blade cover assembly (4, Fig. 1). Raise gauge plate (1, Fig. 4) to its vertical position. Lower the upper guide unit (Fig. 2) to its lowest position.

Place the saw blade over the upper blade pulley (7, Fig. 1) and the lower blade pulley (3, Fig. 1). The blade teeth (5, Fig. 3) must point to the right and

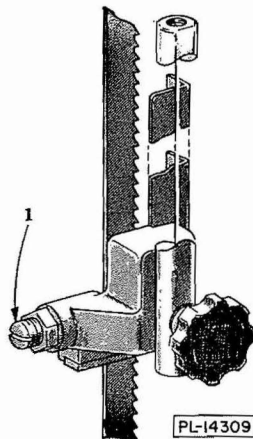

Fig. 2

downward when viewed from the front of the saw. If the teeth do not point downward, remove the blade, twist it inside out and replace it on the saw. Make sure the blade is properly placed in the upper guide unit (Fig. 2).

Turn the tension adjustment hand wheel (8, Fig. 1) to the right until the figure "3" starts to show in the tension indicator (2, Fig. 4). Give the upper blade pulley a few turns by hand so that the blade centers itself on the pulleys. Then turn the tension adjustment hand wheel slowly to the right until the indicator registers approximately "5" at eye level. This is the best operating tension for the blade.

NOTE: See section "J" for adjustment of blade back-up blocks.

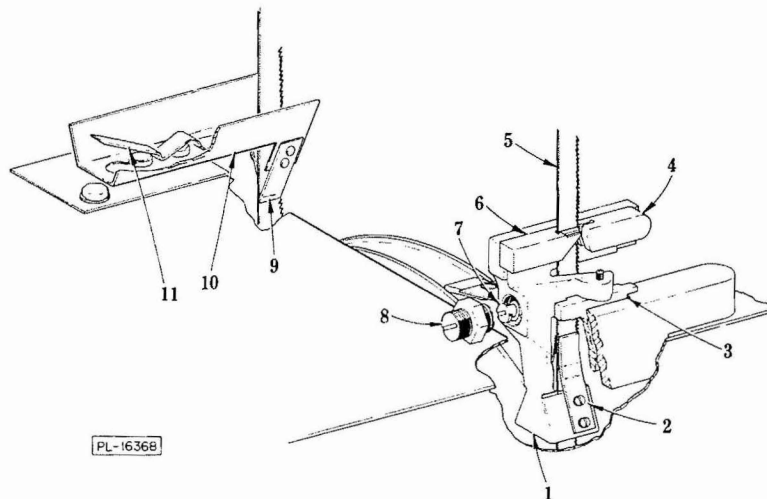

Fig. 3

- B.4 Position the rear wiper assembly (10, Fig. 3) with holes over the slide studs. Slide to right until spring catch (11, Fig. 3) locks assembly in place. Wipers (9, Fig. 3) should be on both sides of blade.
- B.5 Swing up nylon guard (4, Fig. 3). Position front wiper assembly (1, Fig. 3), with blade in slot of steel block (6, Fig. 3) and wipers (2, Fig. 3) on both sides of blade. Align assembly into slot (3, Fig. 3) of wiper bracket slideway and lower into position. Close nylon guard (4, Fig. 3).
- B.6 Close head door (5, Fig. 1) (a permanent magnet holds the door in a closed position).
- B.7 With the gauge plate (1, Fig. 4) in its vertical position (to clear table area), assemble the table (4, Fig. 4). Holding the table in a low position, slide it to the right then back to the left so that the table cross rod hooks onto the stationary clamp (1, Fig. 5). The four table rests (5, Fig. 4) support and align the angles on the under side of the table. Latch the table down with the table clamp (6, Fig. 4). Assemble and latch the blade cover (4, Fig. 1).
- B.8 The carriage may be assembled from either side. Turn the "L" shaped carriage stop (Fig. 6) so that the rubber bumper is toward rear of machine. Align the center bearings of the carriage with the carriage guide (7, Fig. 4). Roll carriage into place. Turn carriage stop (Fig. 6) into stopping position.

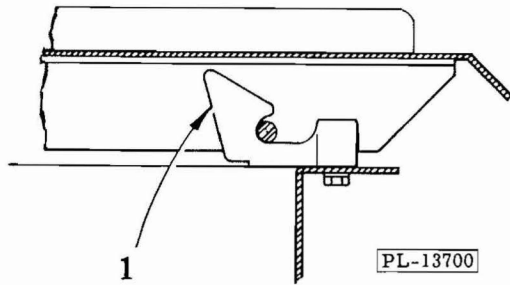

Fig. 5

nected. The meat saw should always be connected except when cleaning or disassembling unit. After cleaning, reconnect to electrical power supply.

D. SAFETY FEATURES:

The Hobart saw is provided with safety devices to give maximum protection to the operator. Keep guards in place at all times.

- D.1 UPPER GUIDE & GUARD ASSY. (9, Fig. 1): Keep as low as the size of the work permits for safety reasons.
- D.2 DOORS: Keep all doors closed while the machine is running.
- D.3 BUTT-END PUSHER (12, Fig. 4): Use the pusher plate as described in section "F.5" and it will be unnecessary to hold your hand near the running saw blade.
- D.4 SWITCH KNOB (10, Fig. 4): Knob must be pulled to start machine. This eliminates chance starting by accidental bumping of knob.

E. LUBRICATION:

Very little lubrication is required, because all the high-speed shafts have either roller or ball bearings which are grease packed and will operate a long time without attention.

- E.1 Keep a small amount of grease in the six ball bearing rollers on the carriage.
- E.2 Apply a few drops of oil frequently to the gauge plate rack (4, Fig. 7) and work the gauge plate assembly back and forth a few times. (See cleaning instructions).
- E.3 For top operating efficiency have your local Hobart service technician check this machine at least once a year.

F. OPERATION:

- F.1 Place the item to be cut on the carriage and turn on the motor switch by pulling switch knob (10, Fig. 4). Stand in front of the machine, leaning lightly against the scalloped front of the carriage, move the carriage to the left, past the saw blade, at a steady and uniform rate. Your left hand will then be free to take away and stack the items as they are cut off. Make it a habit to move your hand around the left side, or back of the saw blade, when reaching for an item — NEVER IN FRONT OF THE TEETH. On the return stroke, pull the item toward you so that it clears the saw blade.
- F.2 If a locked carriage is desired: move the carriage to the point where the right end of the carriage is in line with the right end of the table. The carriage spring lock (11, Fig. 4) is then in alignment with the hole in carriage guide. Tighten the spring lock and the carriage is locked in place. With the locked carriage the SAME Safety Procedure of reaching to the left side (or back) of the saw blade when removing or stacking items should ALWAYS be observed.
- F.3 When cutting slices of uniform thickness, set the gauge plate at the desired position, by turning the adjusting knob (1, Fig. 7). A scale is etched on the table (4, Fig. 4). If the gauge plate is not needed and interferes with the work, it may be moved out of the way by either of the two following methods:
 - (a) Lift the adjusting knob (1, Fig. 7) (to disengage the teeth of the rack (4,

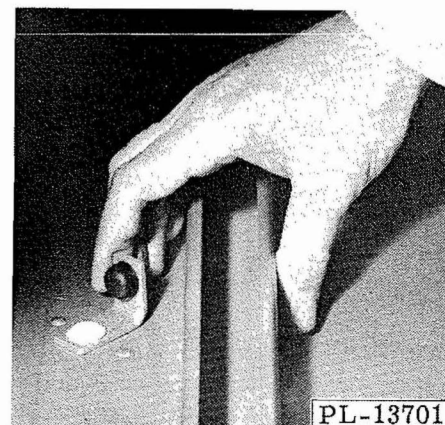

Fig. 6

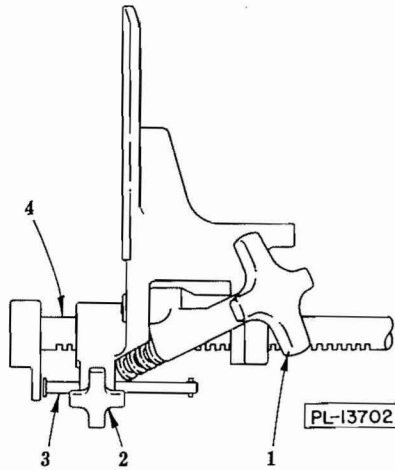

Fig. 7

Fig. 7)) and slide the gauge plate to the rear of the machine.

(b) Raise the gauge plate to a vertical position (1, Fig. 4). In this vertical position, the gauge plate may be slid to any location.

- F.4 The adjustable gauging pin (3, Fig. 7), (after being set), permits the operator to raise the adjusting knob (1, Fig. 7), slide the gauge plate back out of the way, then return the gauge plate to its original setting (turn knob (1, Fig. 7), clockwise to "snugup" gauge plate and make sure rack teeth are engaged). To set the gauging pin, loosen hand knob (2, Fig. 7) and slide pin against the support stop. Tighten hand knob.
- F.5 Use the pusher plate (12, Fig. 4) to hold the meat against the gauge plate when slicing short ends. Dowels in the pusher plate give the necessary alignment with the raised edge of the carriage. A stop on this raised edge of the carriage prevents over-travel. By holding the pusher plate with your right hand, your hand will then always be a safe distance from the saw blade. Store the pusher plate on the under side of the carriage support (11, Fig. 1) when not in use.

G. CLEANING & SANITIZING:

This saw has been designed for quick and easy cleaning. It is **IMPORTANT** that any machine used for the preparation of food be kept in a clean and sanitary condition. Daily cleaning is recommended. Make sure saw is turned "off" and stopped before starting cleaning operation.

PROCEDURE:

- G.1 Turn (at either end) the "L" shaped carriage stop (Fig. 6) and roll off stainless steel carriage.
- G.2 Rotate gauge plate (1, Fig. 4) to raised or vertical position.
- G.3 Open and lift off blade cover (4, Fig. 1).
- G.4 Release table clamp (6, Fig. 4) and remove stainless steel table.
- G.5 Clean the gauge plate rack (4, Fig. 7).
- G.6 Open and lift off head door (5, Fig. 1). Lift out upper pulley wiper (6, Fig. 1). Clean wiper. Do not replace at this time.
- G.7 Swing up nylon guard (4, Fig. 3) and lift out front wiper assembly. Clean unit. Do not replace at this time.
- G.8 Lift spring catch (11, Fig. 3) and slide rear wiper unit (10, Fig. 3) to the left. Left up and off. Clean unit.
- G.9 Open, lift and remove base door (2, Fig. 1).
- G.10 Turn tension adjusting hand wheel, (3, Fig. 4) to the left to release blade tension. Remove saw blade and clean in sink.
- G.11 Remove hand knob (13, Fig. 4). Remove upper guide unit (Fig. 2) (with blade already removed or tension released on blade). Clean, lubricate with TASTELESS oil. Do not replace at this time.
- G.12 Remove upper (7, Fig. 1) and lower (3, Fig. 1) blade pulleys by opening latches (1, Fig. 8) clear of shafts and sliding pulleys from the shafts. Clean pulleys in sink and lubricate bore before replacing.

NOTE: When replacing pulleys, make sure the pulley latches (1, Fig. 8) are properly seated in grooves of shafts. (Upper and lower blade pulleys are interchangeable).

- G.13 All areas are now exposed for easy and thorough cleaning via one of the two following procedures:

G.13.1 HAND CLEANING:

- G.13.1.1 Materials required:

- G.13.1.1.1 Small nylon bristled brush with (approx.) 12" handle.
- G.13.1.1.2 Small plastic two compartment pail.
- G.13.1.1.3 Clean cloths.
- G.13.1.1.4 Cleaner ("Soilax" All Purpose Cleaner).
- G.13.1.1.5 Sanitizer ("Mikro-Klene" iodophor sanitizer).
- G.13.1.1.6 Plastic spray bottle (for sanitizer).
- G.13.1.2 Procedure (using "Soilax" and "Mikro-Klene"):
 - G.13.1.2.1 Add two ounces of "Soilax" All Purpose Cleaner to a gallon of hot water in wash side of two compartment pail.
 - G.13.1.2.2 Mix rinse solution by adding two teaspoons of "Mikro-Klene" in one gallon of cool water in rinse side of pail.
 - G.13.1.2.3 Brush out large scraps of soil and meat waste.
 - G.13.1.2.4 Begin cleaning in the upper pulley area. Brush thoroughly all surfaces being sure to get in corners. Work your way down, being sure to dip the brush frequently into the cleaning solution.
 - G.13.1.2.5 Similarly clean the top area (which was covered by the table and the carriage). Work down into the lower pulley housing.
 - G.13.1.2.6 Remove the scrap pan and wash separately in sink, Brush clean, the housing and the area around the scrap pan.
 - G.13.1.2.7 Rinsing and sanitizing can be done in one of two ways:
 - (a) Go over all cleaned surfaces with a cloth soaking wet in the "Mikro-Klene" rinse solution.
 - (b) Rinse in fresh water and apply "Mikro-Klene" solution via of spray bottle.

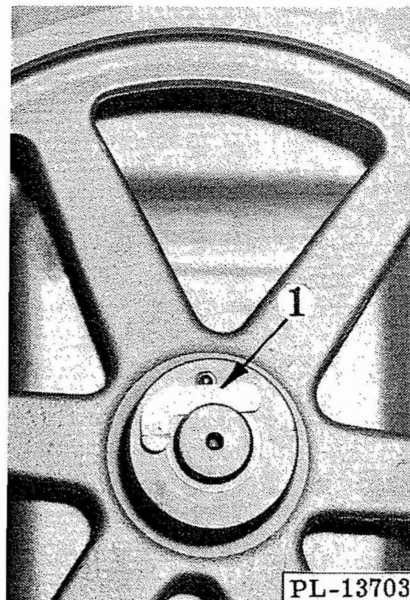

Fig. 8

- G.13.1.2.8 Allow all surfaces to drain dry and then reassemble. Do not wipe dry.
- G.13.1.2.9 Protect saw from recontamination by covering.
- G.13.1.2.10 Rinse the nylon brush thoroughly under running water. Then dip the brush in standard solution of "Mikro-Klene" and allow to drain dry in covered container or wrapped in a freshly laundered towel. Cloth used for rinsing should be sent to laundry, or discarded. Wash out pails.
- G.13.2 HYDRAULIC CLEANING:
 - G.13.2.1 Materials required (Economics Laboratory System).
 - G.13.2.1.1 Model E "Mikro-Spray" (Economics Laboratory, Inc.).
 - G.13.2.1.3 "Mikro-Quat" detergent-sanitizer.
 - G.13.2.2 Procedure:
 - G.13.2.2.1 Insert an eight ounce bottle of "Mikro-Quat" into the Model E "Mikro-Spray" and turn on the hot water.
 - G.13.2.2.2 Spray clean and sanitize both pulley housings and the table

area. Be sure to get the hose stream into all corners. Stubborn soil may require a little brushing.

G.13.2.2.3 Rinse with fresh water from another hose and allow to drain dry. Cover and store as in procedure G.13.1.

G.13.2.2.4 Either a floor drain or a wet vacuum pick-up machine is required to dispose of the cleaning and rinsing solutions. It may also be desirable to have a portable shower curtain type arrangement to prevent excess splashing into other areas of the work space.

H. CHANGING SAW BLADES:

- H.1 Turn the left-hand carriage stop (see section G.1) and move the carriage to the left a few inches beyond the nylon guard (4, Fig. 3).
- H.2 Raise gauge plate (1, Fig. 4) to vertical position.
- H.3 Turn tension adjusting hand wheel (3, Fig. 4) to left to release blade tension.
- H.4 Remove blade cover assembly (4, Fig. 1).
- H.5 Release table clamp (6, Fig. 4) and remove table.
- H.6 Open head door (5, Fig. 1).
- H.7 Swing up nylon guard (4, Fig. 3).
- H.8 Remove saw blade.
- H.9 Assemble new blade. Make sure front and rear lower blade wipers are on both sides of blade.

H.10 Turn the tension adjusting hand wheel (3, Fig. 4) to the right until the edge of the "3" first appears in the window (2, Fig. 4).

H.11 Turn the upper blade pulley (7, Fig. 1) by hand to center the blade.

H.12 Turn the tension adjusting hand wheel to the right until the indicator (2, Fig. 4) registers "4" at eye level.

H.13 Close the lower nylon guard (4, Fig. 3).

H.14 Reassemble table and other disassembled parts.

J. ADJUSTMENT OF BLADE BACK-UP BLOCK:

Special TUNGSTEN CARBIDE blade back-up blocks take the cutting thrust. They are located at the back edge of the saw blade, in the upper guide (Fig. 2) and the front lower wiper unit (Fig. 3).

J.1 Adjust the upper back-up block by turning screw (1, Fig. 2).

J.2 Adjust the lower back-up block (7, Fig. 3) by turning screw (8, Fig. 3).

NOTE: Clearance between back-up blocks and blade should be approximately $1/32$ " (with the saw running without load). ALWAYS check and adjust to this dimension after changing saw blades, as blade widths may vary.

K. BLADE REPLACEMENT:

One long life blade is furnished with each meat saw. Replacement blades are available through all Hobart offices.

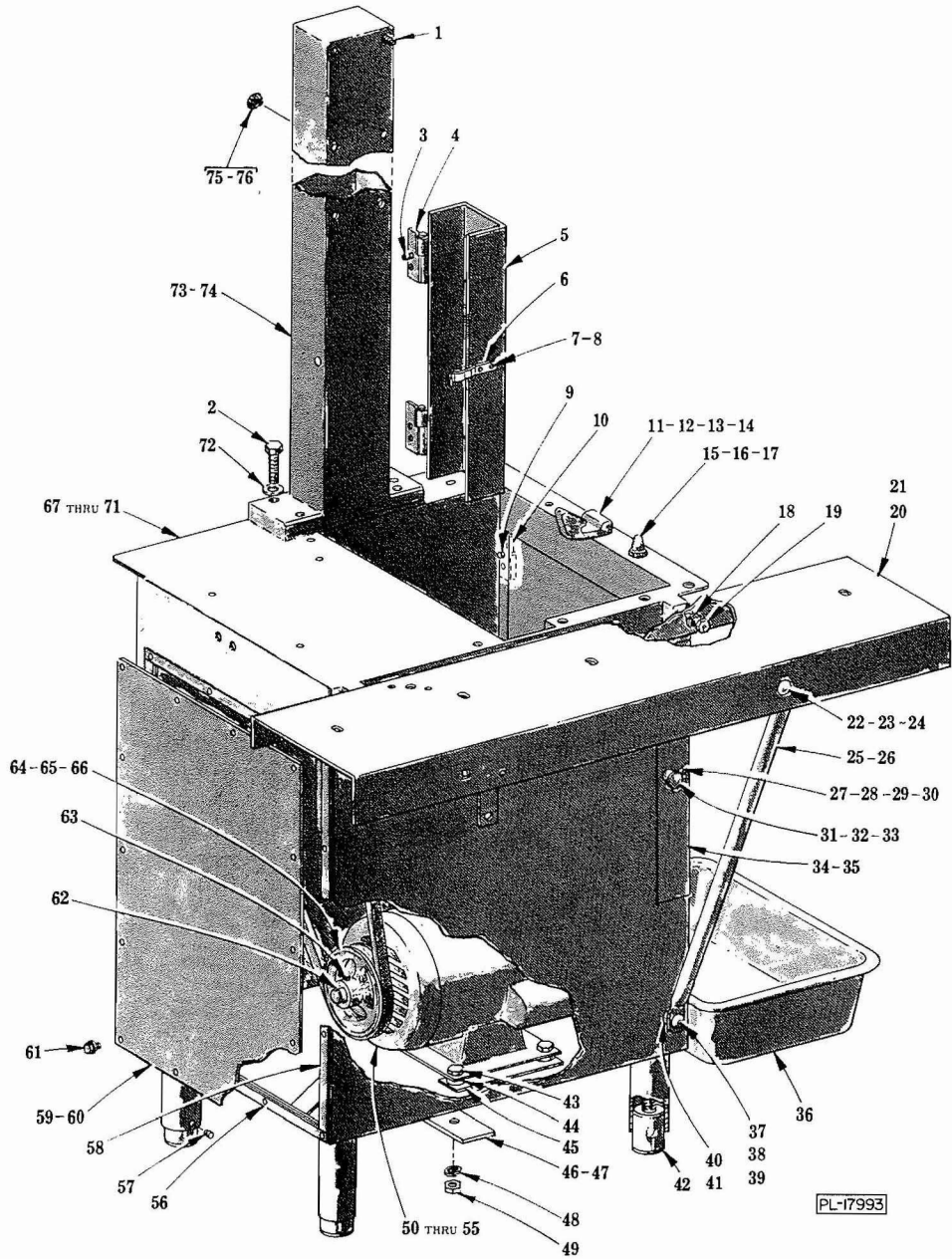

BASE UNIT

ILLUS. PL-17993	PART NO.	NAME OF PART	AMT.
	1	Self-Tapping Screw - 3/8"-16 x 3/4" Soc. Hd., Type TT	8
	2	Cap Screw - 1/2"-13 x 1-1/2" Hex Hd. "Nylok"	4
	3	Self-Tapping Screw - #10-32 x 3/4" Phil. Flat Hd. "Taptite"	4
	4	Bracket - Hinge	2
	5	D-122374 Blade Cover Assy	1
	6	M-68176 Clip - Spring	1
	7	SC-53-1 Mach. Screw - #10-24 x 1/4" Truss Hd	2
	8	WL-8-13 Lock Washer - #10 Int. Shakeproof	2
	9	SD-24-29 Self-Tapping Screw - #10-32 x 3/4" Phil. Flat Hd. "Taptite"	4
	10	P-78917 Bracket - Hinge	2
	11	C-102359 Clamp - Stationary Table	1
	12	SC-37-83 Cap Screw - 5/16"-18 x 5/8" Hex Hd	2
	13	WS-17-16 Washer	2
	14	WL-3-47 Lock Washer - 5/16" Medium	2

BASE UNIT (Cont.)

ILLUS. PL-17993	PART NO.	NAME OF PART	AMT.
15	B-124328	Rest - Table	4
16	SC-62-53	Cap Screw - 1/4"-20 x 1/2" Hex Hd	4
17	WL-3-38	Lock Washer - 1/4" Medium	4
18	WL-4-4	Lock Washer - 3/8" Light	2
19	SC-62-43	Cap Screw - 3/8"-16 x 3/4" Hex Hd	2
20	C-290665-1	Carriage Support Assy. (Painted Mach.)	1
21	C-290665-2	Carriage Support Assy. (SST Mach.)	1
22	SC-82-38	Carriage Bolt - 3/8"-16 x 1"	2
23	WL-4-4	Lock Washer - 3/8" Light	2
24	NS-13-25	Full Nut - 3/8"-16 Hex Fin	2
25	S-78993-1	Brace - Carriage Support (Painted Mach.)	2
26	S-78993-2	Brace - Carriage Support (SST Mach.)	2
27	SC-8-9	Mach. Screw - #10-24 x 3/8" Rd. Hd	1
28	NS-9-22	Mach. Nut - #10-24 Hex	1
29	M-68176	Clip - Spring	1
30	WL-13-11	Lock Washer - #10 Int. Shakeproof	1
31	B-120039	Knob - Base Door	1
32	SC-8-9	Mach. Screw - #10-24 x 3/8" Rd. Hd	1
33	WL-13-11	Lock Washer - #10 Int. Shakeproof	1
34	E-102380-1	Base Door Assy. (Painted Mach.)	1
35	E-102380-2	Base Door Assy. (SST Mach.)	1
36	E-104075	Pan - Meat Scrap	1
37	SC-82-38	Carriage Bolt - 3/8"-16 x 1"	2
38	WL-4-4	Lock Washer - 3/8" Light	2
39	NS-13-25	Full Nut - 3/8"-16 Hex Fin	2
40	M-74888-1	Washer - Shim (Painted Mach.)	2
41	M-74888-2	Washer - Shim (SST Mach.)	2
42	B-290349	Foot & Insert Assy	4
43	SC-37-74	Cap Screw - 3/8"-16 x 1-1/2" Hex Hd	4
44	M-74888-1	Washer - Shim	4
45	B-122706	Booster - Motor	AR
46	C-119810-2	Reinforcement - Base (Painted Mach.)	2
47	C-119810-3	Reinforcement - Base (SST Mach.)	2
48	WL-4-4	Lock Washer - 3/8" Light	4
49	NS-13-25	Full Nut - 3/8"-16 Hex Fin	4
50	D-278201-1	Motor (115/200-230 V., 60 Hz., 1 Ph.) (1725 R.P.M.) (Incls. item #62)	1
51	B-294121	Motor (200-230/460 V., 60 Hz., 3 Ph.) (1725 R.P.M.) (Incls. item #62)	1
52	D-118298-2	Motor (115/220-240 V., 50 Hz., 1 Ph.) (1425 R.P.M.) (Incls. item #62)	1
53	D-118306-2	Motor (220-240/380-415 V., 50 Hz., 3 Ph.) (1425 R.P.M.) (Incls. item #62)	1
54	D-118430-1	Motor (200/230/460 V., 60 Hz., 3 Ph.) (3450 R.P.M.) (Incls. item #62)	1
55	D-118430-2	Motor (220-240/380-415 V., 50 Hz., 3 Ph.) (2850 R.P.M.) (Incls. item #62)	1
56	B-103193	Gasket (Short)	2
57	SC-111-5	Set Screw - 1/4"-20 x 1/4" Hdls., Cup Pt. "Nylok"	4
58	B-103192	Gasket (Long)	2
59	A-110386-1	Motor Access Panel & Gasket Assy. (Painted Mach.) (Incls. items #56 & 58)	1
60	A-110386-2	Motor Access Panel & Gasket Assy. (SST Mach.) (Incls. items #56 & 58)	1
61	SD-32-15	Self-Tapping Screw - #10-32 x 3/8" Hex Washer Hd. "Taptite"	14
62	R-12430-62	Key	1
63	SC-47-32	Set Screw - 5/16"-18 x 5/16" Soc. Hdls., Cup Pt	1
64	C-119949-1	"V" Pulley - Motor (5.25" O.D.) (60 Hz.) (Incls. item #63)	1
65	C-119949-2	"V" Pulley - Motor (5.95" O.D.) (50 Hz.) (Incls. item #63)	1
66	C-119949-4	"V" Pulley - Motor (4.95" O.D.) (60 Hz.) (Incls. item #63)	1
67	E-122396	Base Assy. (Painted Mach.) (Incls. items #9 & 10)	1
68	E-122395	Base Assy. (SST Mach.) (Incls. items #9 & 10)	1
69	C-118544-1	Lug - Solderless	1
70	WL-13-11	Lock Washer - #10 Int. Shakeproof	2
71	NS-11-18	Mach. Nut - #10-24 Hex	2
72	WS-8-48	Washer	4
73	D-122373-3	Column Assy. (Painted Mach.) (Incls. items #3 & 4)	1
74	D-122373-4	Column Assy. (SST Mach.) (Incls. items #3 & 4)	1
75	B-123993	Plug Button (Painted Mach.)	8
76	PB-3-6	Plug Button (SST Mach.)	8

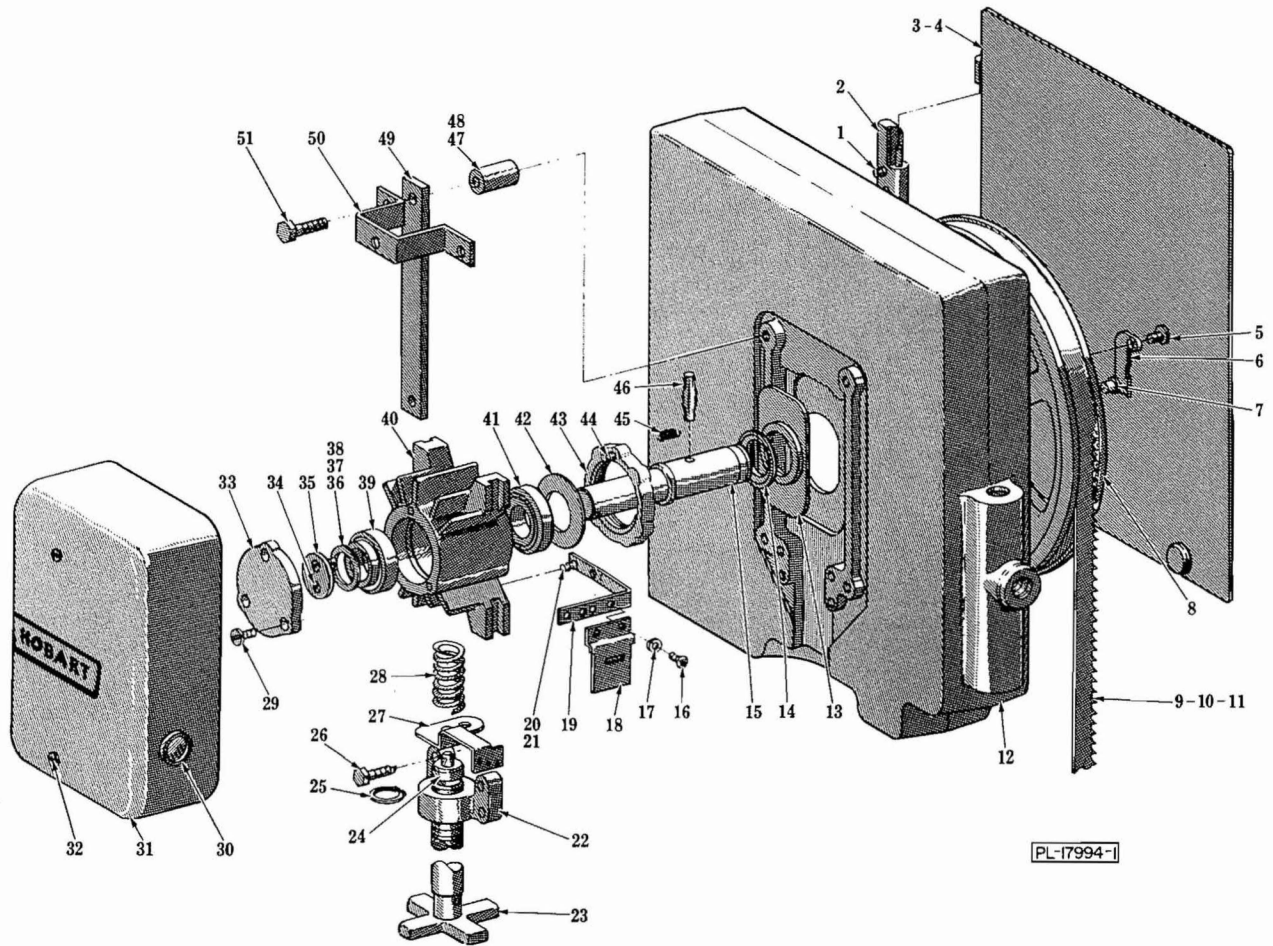

HEAD UNIT

HEAD UNIT

ILLUS. PL-17994-1 NO.	PART	NAME OF PART	AMT.
1	SC-20-15	Mach. Screw - #10-24 x 7/8" Phil. Flat Hd	4
2	P-78917	Bracket - Hinge	2
3	C-122505-1	Door Assy. (Head) (60 Hz.)	1
4	C-122505-2	Door Assy. (Head) (50 Hz.)	1
5	M-20851	Screw - Latch	1
6	M-20852	Latch	1
7	M-79686	Catch - Friction	1
8	A-108224-2	Flanged Pulley (Blade) Assy. (Incls. items #5, 6 & 7)	1
9	B-124445-1	Blade - Meat Saw (.020" - 4T) (Standard)	1
10	B-124445-2	Blade - Meat Saw (.020" - 3T) (Frozen Beef/Fish)	1
11	B-124445-3	Blade - Meat Saw (.014" - 4T) (Frozen Fish)	1
12	D-102526-8	Head & Magnetic Catch Assy	1
13	B-103288	Shield - Bearing Carrier	1
14	A-103178	Seal	1
15	C-108226	Shaft - Upper Bearing Carrier	1
16	SC-7-71	Mach. Screw - #10-24 x 1/4" Rd. Hd	2
17	WL-3-22	Lock Washer - #10 Light	2
18	P-67249	Plate - Blade Tension Sight	1
19	P-75817	Bracket - Tension Indicator	1
20	SC-90-45	Cap Screw - #10-24 x 3/8" Hex Hd	2
21	WL-3-22	Lock Washer - #10 Light	2
22	P-75897	Nut - Blade Tension Adjusting	1
23	C-120469-2	Hand Wheel & Screw Assy	1
24	BB-13-1	Thrust Bearing - Nice #603	1
25	RR-4-8	Retaining Ring	1
26	SD-33-66	Self-Tapping Screw - 5/16"-18 x 1-1/4" Hex Washer Hd., Type TT	4
27	P-75816	Indicator - Tension	1
28	M-20867	Spring - Adj. Blade Tension	1
29	SC-12-69	Mach. Screw - 1/4"-20 x 1/2" Fil. Hd	3
30	M-75656	Window Unit	1
31	C-120830	Cover & Window Assy. (Incls. item #30)	1
32	SD-31-1	Self-Tapping Screw - #10-24 x 5/8" Truss Hd. "Taptite"	2
33	P-67210	Cap - Upper Bearing Carrier	1
34	SC-99-4	Cap Screw - #10-24 x 1/2" Flat Hd. "Eslok"	2
35	M-67241	Retainer - Bearing	1
36	A-103036-1	Washer - Shim (.002" Thk.)	AR
37	A-103036-2	Washer - Shim (.005" Thk.)	AR
38	A-103036-3	Washer - Shim (.008" Thk.)	AR
39	BR-2-27	Roller Bearing - Cone & Cup Assy	1
40	D-103022	Carrier - Upper Bearing	1
41	BR-2-27	Roller Bearing - Cone & Cup Assy	1
42	B-103290	Plate - Bearing Carrier	1
43	B-103029	Cap - Upper Bearing Carrier (Pulley)	1
44	SC-12-69	Mach. Screw - 1/4"-20 x 1/2" Fil. Hd	3
45	M-75837	Spring - Detent	2
46	B-110551	Groov-Pin - Special	1
47	B-123176-1	Spacer - Bearing Carrier (Upper)	2
48	B-123176-4	Spacer - Bearing Carrier (Lower)	2
49	P-67187	Gib - Upper Bearing Carrier	2
50	P-67147	Cover Bracket & Weld Nut Assy	2
51	SD-33-60	Self-Tapping Screw - 3/8"-16 x 1-7/8" Hex Washer Hd., Type TT	4
	C-108227	Upper Bearing Carrier Assy. (Incls. items #13 thru 15, 29 & 33 thru 46)	1

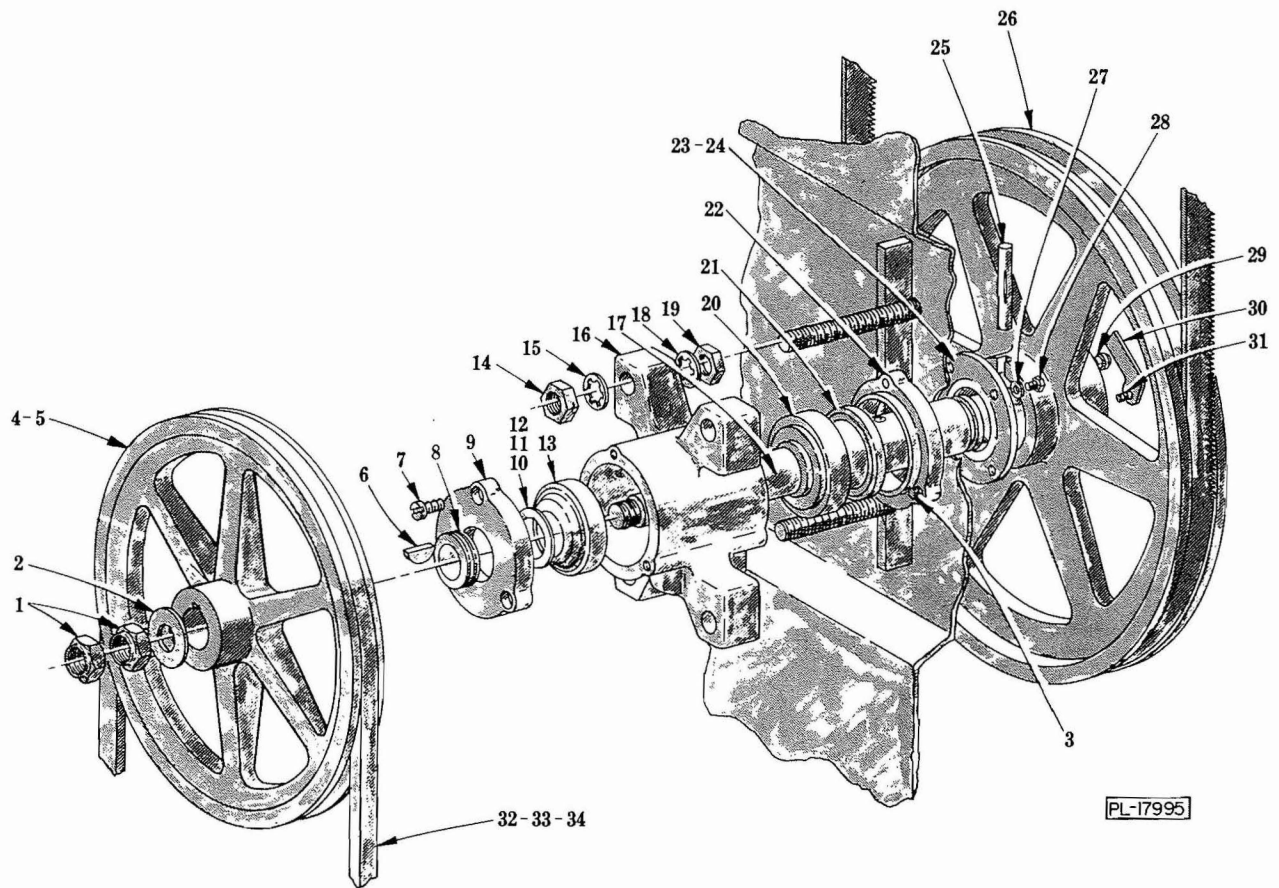

LOWER BEARING CARRIER UNIT

LOWER BEARING CARRIER UNIT

ILLUS. PL-17995	PART NO.	NAME OF PART	AMT.
1	NS-31-43	Stop Nut - 3/4"-16 "Elastic"	2
2	WS-29-12	Washer	1
3	SC-12-69	Mach. Screw - 1/4"-20 x 1/2" Fil. Hd	3
4	C-119950	"V" Pulley - Bearing Carrier (9.8" O.D.) (1425 & 1725 R.P.M. Motor)	1
5	R-83776	"V" Pulley - Bearing Carrier (12-3/4" O.D.) (2850 & 3450 R.P.M. Motor)	1
6	KW-3-15	Key - #807 Woodruff	1
7	SC-12-69	Mach. Screw - 1/4"-20 x 1/2" Fil. Hd	3
8	B-114560	Conveyor - Lower Bearing Carrier Grease	1
9	C-114561	Cap - Lower Bearing Carrier ("V" Belt Side)	1
10	B-123192-1	Washer - Shim (.002" Thk.)	AR
11	B-123192-2	Washer - Shim (.005" Thk.)	AR
12	B-123192-3	Washer - Shim (.008" Thk.)	AR
13	BR-2-27	Roller Bearing - Cone & Cup Assy	1
14	NS-13-30	Full Nut - 1/2"-13 Hex Fin	4
15	WL-8-31	Lock Washer - 1/2" Int. Shakeproof	4
16	D-114562	Carrier - Lower Bearing	1
17	D-119851	Shaft - Lower Bearing Carrier	1
18	WL-8-31	Lock Washer - 1/2" Int. Shakeproof	4
19	NS-13-30	Full Nut - 1/2"-13 Hex Fin	4
20	BR-2-20	Roller Bearing - Cone & Cup Assy	1
21	M-71403	Seal - Grease	1
22	M-77319	Bearing Cap & Seal Assy. (Incls. item #21)	1
23	M-77510-2	Washer & Seal Assy. (Incls. item #24)	1
24	M-77511	Seal - Diaphragm	1
25	B-110551	Groov-Pin - Special	1
26	A-108224-2	Flanged Pulley (Blade) Assy. (Incls. items #29, 30 & 31)	1
27	WS-23-34	Washer	4
28	SC-67-12	Mach. Screw - #10-32 x 5/16" Trimmed Hex Hd	4
29	M-79686	Catch - Friction	1
30	M-20852	Latch	1
31	M-20851	Screw - Latch	1
32	B-120273-1	"V" Belt (1425 & 1725 R.P.M. Motor) (50/60 Hz.)	1
33	B-122720-1	"V" Belt (3450 R.P.M. Motor) (60 Hz.)	1
34	B-120337-1	"V" Belt (2850 R.P.M. Motor) (50 Hz.)	1
	C-117022-3	Lower Bearing Carrier Assy. (Incls. items #3, 7 thru 13, 16, 17, 20 & 22)	1

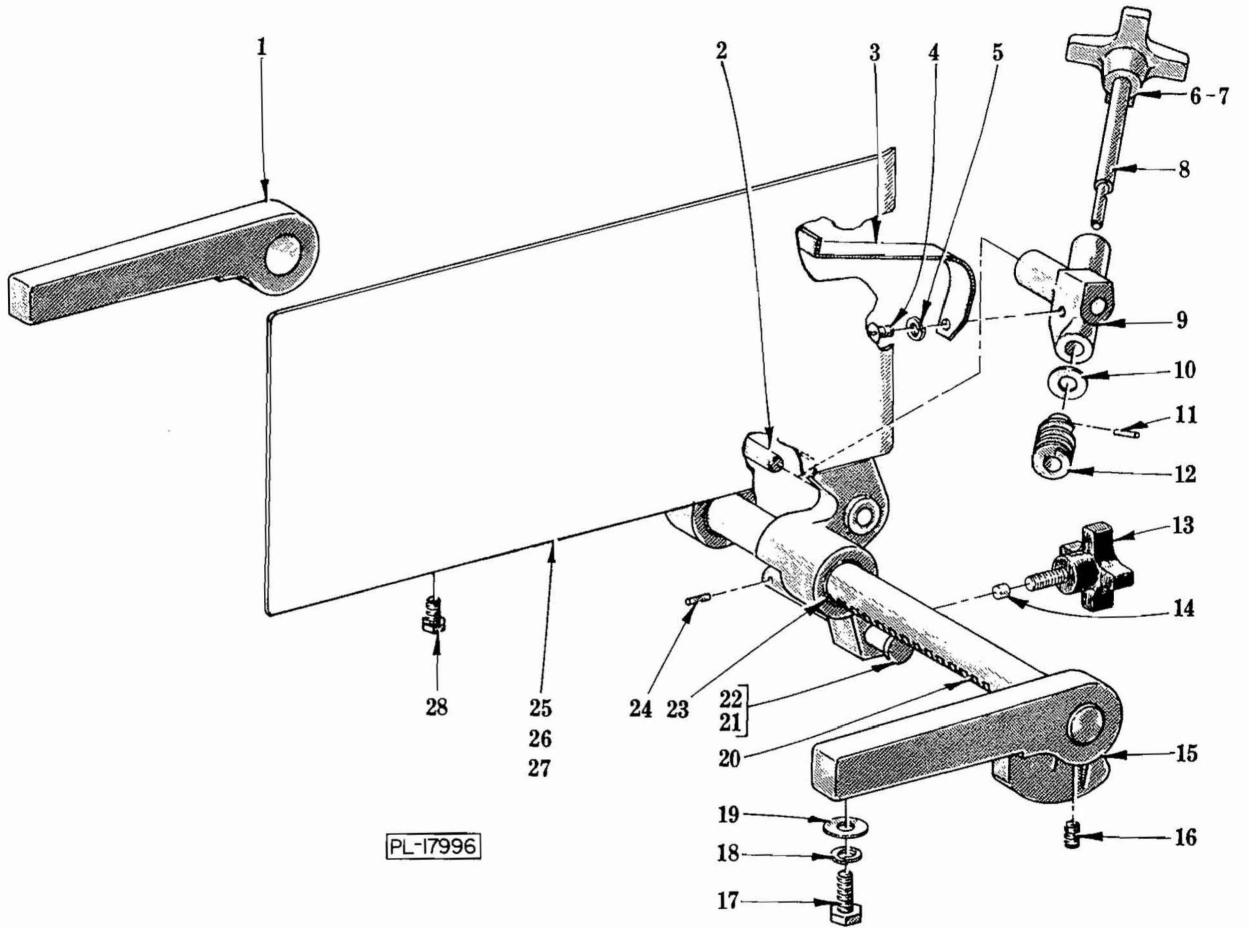

PL-17996

GAUGE PLATE UNIT

GAUGE PLATE UNIT

ILLUS. PL-17996	PART NO.	NAME OF PART	AMT.
1	R-77958	Bracket - Gauge Plate Support (Rear)	1
2	M-77235	Pin	1
3	P-77848	Spring - Gauge Plate	1
4	SC-21-14	Mach. Screw - #8-32 x 3/8" Rd. Hd	1
5	WL-6-1	Lock Washer - #8 Light	1
6	B-118551	Knob	1
7	SC-111-5	Set Screw - 1/4"-20 x 1/4" Soc. Hdls., Cup Pt. "Nylok"	1
8	M-77843	Shaft - Worm	1
9	M-83481	Worm Bracket & Bearing Assy	1
10	WS-18-36	Washer	1
11	PG-7-7	Groov-Pin - Type #5, 1/8" x 7/16"	1
12	M-20887	Worm	1
13	C-118958-1	Knob - Positioning	1
14	M-78920	Slug	1
15	R-78915	Bracket - Gauge Plate Support (Front)	1
16	SC-103-10	Set Screw - 5/16"-18 x 3/8" Soc. Hdls., Cup Pt. "Unbrako/Loc-well"	2
17	SC-62-44	Cap Screw - 5/16"-18 x 3/4" Hex Hd	4
18	WL-3-47	Lock Washer - 5/16" Medium	4
19	WS-17-16	Washer	4
20	P-77841-1	Rack - Gauge Plate	1
21	M-85397	Gauging Pin	1
22	WS-18-36	Washer	1
23	M-74424	Bushing - Gauge Plate	2
24	PG-11-2	Groov-Pin - Type #5, 7/64" x 1/2"	1
25	D-120136-2	Gauge Plate Assy. (SST) (USDA)	1
26	C-120138	Arm & Bushing Assy. (SST) (USDA) (Incls. item #23)	1
27	NS-25-4	Acorn Nut - 1/4"-20	6
28	M-79155	Cap Screw Bolt (Special)	1
	E-120139-2	Gauge Plate Assy. (SST) (USDA) (Incls. items #2 thru 14 & 21 thru 28)	1
	D-124056-1	Gauge Plate Assy. (SST) (USDA) (Incls. items #25, 26 & 27)	1
	P-77846	Worm Bracket Assy. (Incls. items #3 thru 12)	1

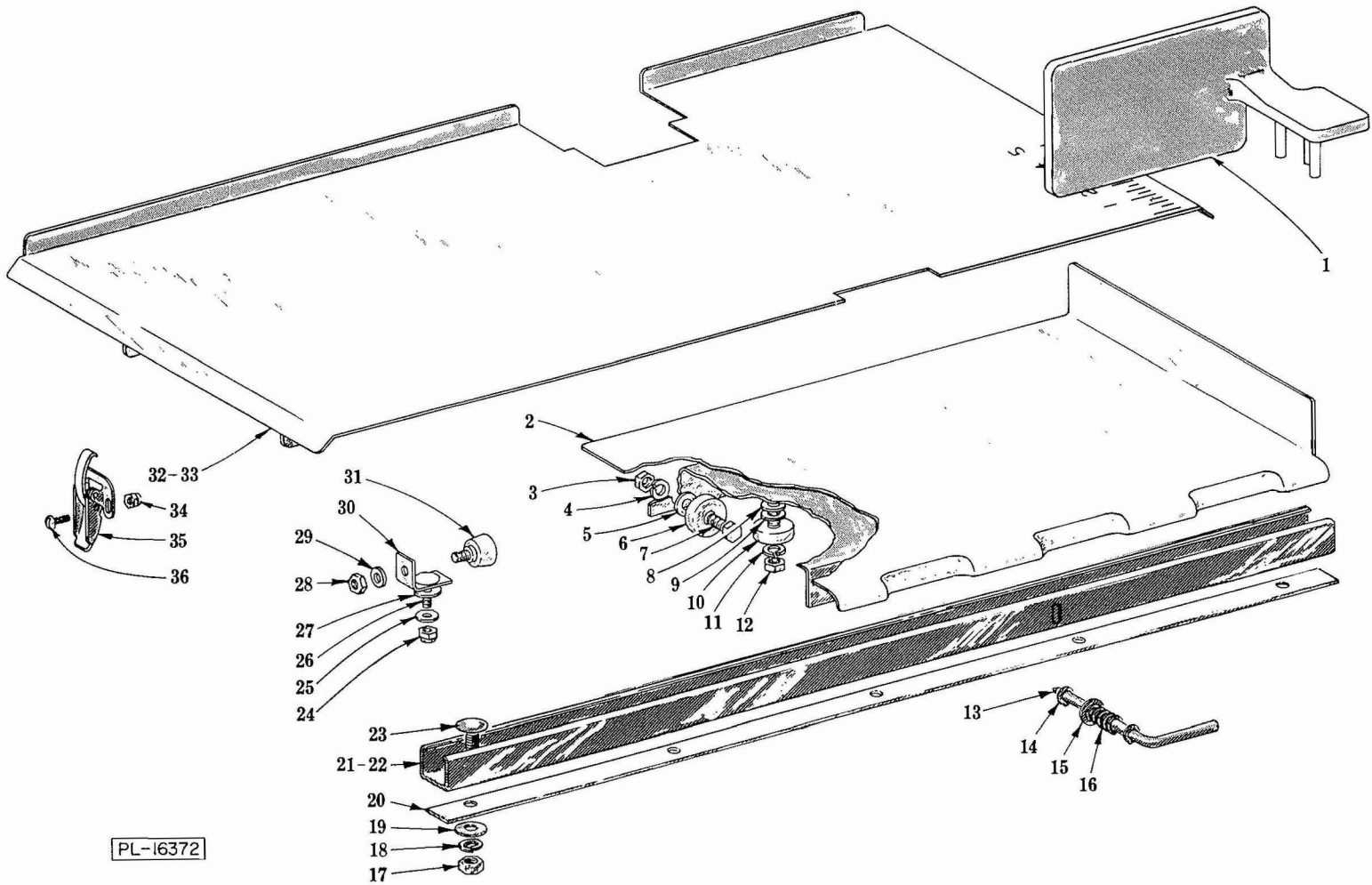

PL-16372

TABLE, CARRIAGE AND TRACK UNIT

TABLE, CARRIAGE AND TRACK UNIT

ILLUS. PL-16372	PART NO.	NAME OF PART	AMT.
1	P-77576-1	Pusher Plate Assy	1
2	D-124059	Carriage Assy	1
3	NS-13-25	Full Nut - 3/8"-16 Hex Fin	4
4	WL-4-4	Lock Washer - 3/8" Light	4
5	WS-18-5	Washer	4
6	BB-8-11	Ball Bearing - Nice #SK-T2198	4
7	SC-37-73	Cap Screw - 3/8"-16 x 1" Hex Hd	4
8	WS-18-14	Washer (3/64" Thk.)	2
9	WS-18-34	Washer (.010" Thk.)	AR
10	BB-8-11	Ball Bearing - Nice #SK-T2198	2
11	WL-4-4	Lock Washer - 3/8" Light	2
12	NS-13-25	Full Nut - 3/8"-16 Hex Fin	2
13	C-123347	Bar - Carriage Lock	1
14	RR-11-9	Retaining Ring	3
15	WS-17-8	Washer	1
16	B-123343	Spring - Carriage Locking	1
17	NS-15-11	Full Nut - 5/16"-18 Hex Fin	5
18	WL-6-23	Lock Washer - 5/16" Medium	5
19	WS-17-21	Washer	5
20	P-78994-2	Spacer	1
21	S-78990-3	Carriage Guide Assy. (Painted Mach.)	1
22	S-78990-4	Carriage Guide Assy. (SST Mach.)	1
23	SC-94-20	Carriage Bolt - 5/16"-18 x 1"	5
24	NS-31-29	Stop Nut - 5/16"-18 "Elastic"	2
25	M-70087	Washer - Spring	2
26	SC-94-20	Carriage Bolt - 5/16"-18 x 1"	2
27	WS-18-34	Washer	2
28	NS-15-11	Full Nut - 5/16"-18 Hex Fin	2
29	WS-17-21	Washer	2
30	B-119827	Stop - Carriage	2
31	B-18682-2	Bumper - Carriage Stop	2
32	D-102348-1	Table Assy. (Painted Mach.)	1
33	D-102348-2	Table Assy. (SST Mach.)	1
34	NS-31-10	Stop Nut - #10-24 "Elastic"	2
35	M-67319	Clamp - Table	1
36	SC-10-36	Mach. Screw - #10-24 x 5/8" Truss Hd	2
	D-124064-1	Carriage Unit Assy. (Incls. items. #2 thru 16)	1

LOWER GUIDE AND WIPER UNIT

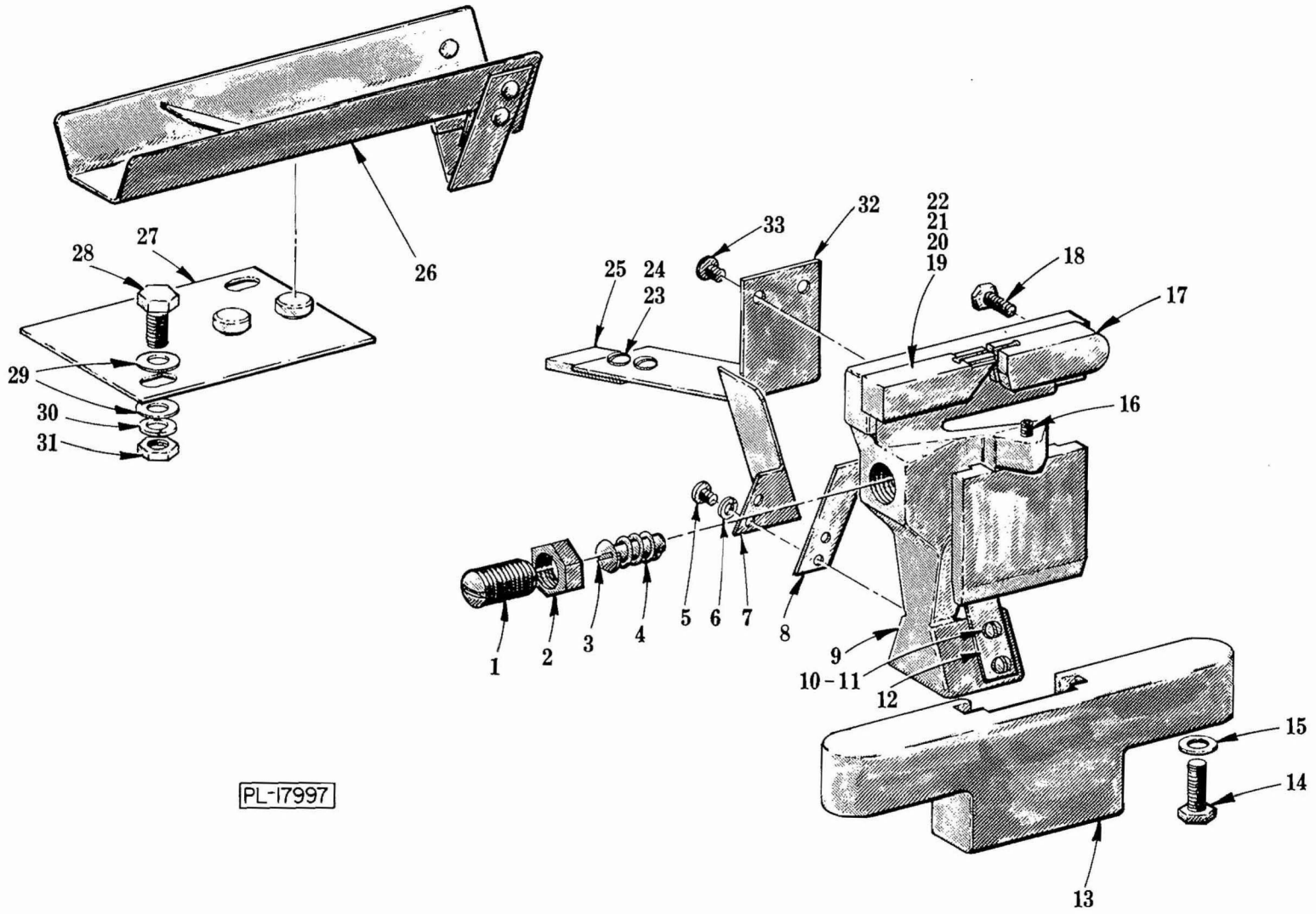

PL-17997

LOWER GUIDE AND WIPER UNIT

ILLUS. PL-17997	PART NO.	NAME OF PART	AMT.
1	SC-49-22	Set Screw - 9/16"-18 x 7/8" Hdls., Flat Pt	1
2	NS-18-33	Jam Nut - 9/16"-18 Hex Fin	1
3	M-101924	Blade Back Up Block Assy	1
4	M-101925	Spring - Back Up Block	1
5	SC-21-85	Mach. Screw - #8-32 x 3/16" Rd. Hd	2
6	WL-6-2	Lock Washer - #8 Medium	2
7	B-121168	Deflector - Scrap	1
8	B-121170	Scraper - Blade	1
9	B-121660	Lower Wiper Support & Bushing Assy	1
10	WL-6-2	Lock Washer - #8 Medium	2
11	SC-21-85	Mach. Screw - #8-32 x 3/16" Rd. Hd	2
12	B-121170	Scraper - Blade	1
13	C-121162	Slideway - Front Wiper	1
14	SC-37-75	Cap Screw - 5/16"-18 x 3/4" Hex Hd	2
15	WS-17-16	Washer	2
16	SC-109-84	Set Screw - #10-24 x 5/8" Soc. Hdls., Flat Pt	1
17	B-102653	Guard - Saw Blade	1
18	SC-41-61	Cap Screw - 1/4"-28 x 3/4" Hex Hd	2
19	B-109142-4	Guide - Saw Blade (.020" Blade) (Standard)	1
20	B-109142-2	Guide - Saw Blade (.014" Blade)	1
21	B-109142-3	Guide - Saw Blade (.038" Blade)	1
22	B-109142-1	Guide - Saw Blade (.026" Blade)	1
23	WS-23-34	Washer	2
24	SC-53-1	Mach. Screw - #10-24 x 1/4" Truss. Hd	2
25	B-123886	Wiper - Pulley	1
26	C-124266	Rear Wiper Assy	1
27	B-121158	Rear Wiper Base Assy	1
28	SC-62-54	Cap Screw - 1/4"-20 x 3/4" Hex Hd	2
29	WS-3-45	Washer	4
30	WL-3-38	Lock Washer - 1/4" Medium	2
31	NS-13-2	Full Nut - 1/4"-20 Hex Fin	2
32	C-123809-1	Spring - Pulley Wiper	1
33	SD-15-3	Self-Tapping Screw - #10-24 x 1/4" Pan Hd. "Taptite"	2
	D-123846-1	Lower Guide & Wiper Assy. (.020" Blade) (Incls. items #1 thru 12 & 16, 17, 18, 19, 23, 24, 25, 32 & 33)	1
	D-123846-2	Lower Guide & Wiper Assy. (.014" Blade) (Incls. items #1 thru 12 & 16, 17, 18, 20, 23, 24, 25, 32 & 33)	1

5614 REPLACEMENT PARTS

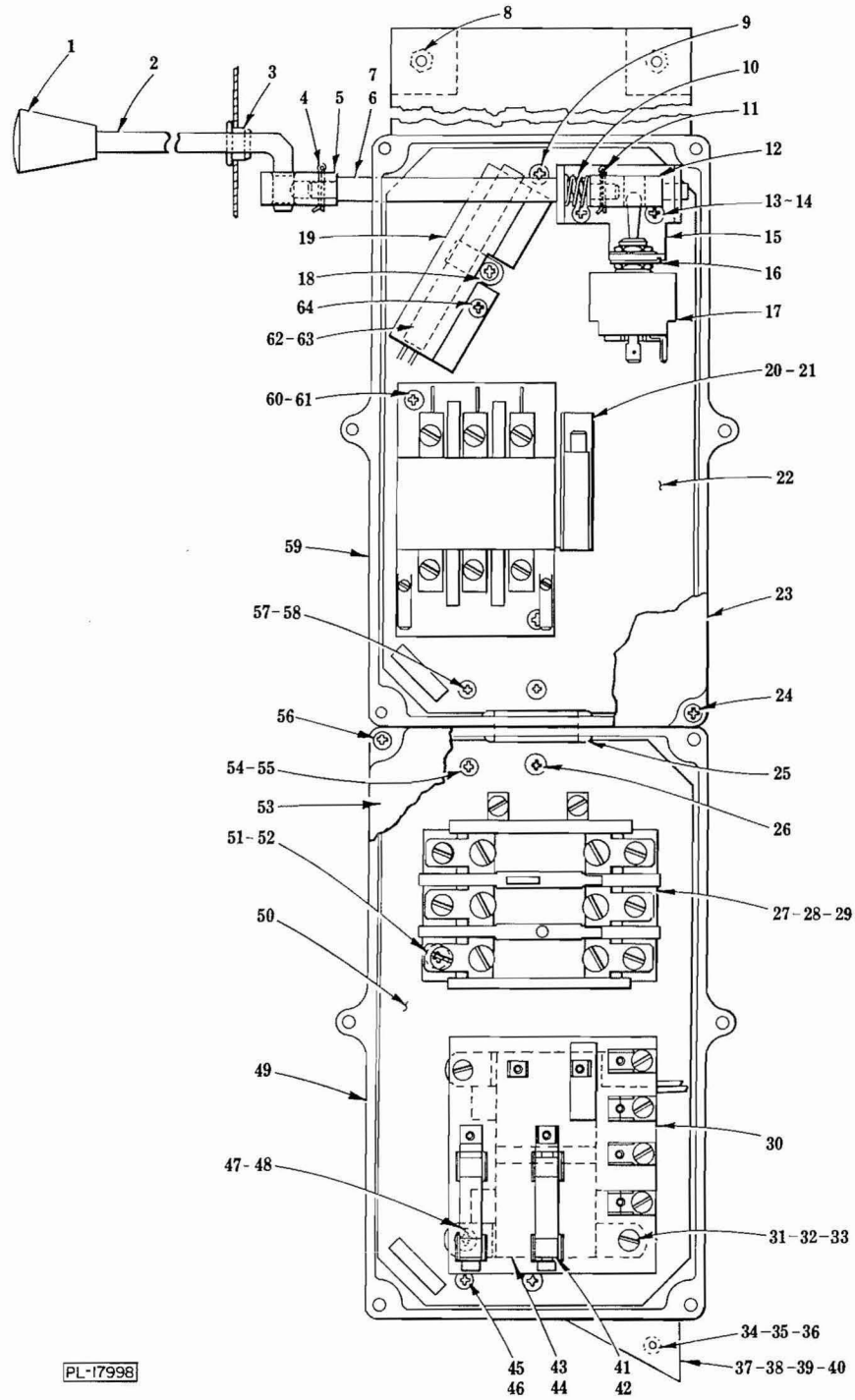

ELECTRICAL UNIT

ILLUS. PL-17998	PART NO.	NAME OF PART	AMT.
1	B-120054-2	Knob - Switch	1
2	C-121537-3	Rod - Switch Operating (Standard)	1
3	B-121539	Bushing - Switch Rod	1

ELECTRICAL UNIT (Cont.)

ILLUS. PL-17998	PART NO.	NAME OF PART	AMT.
4	PC-5-8	Cotter Pin - 3/32" x 5/8"	1
5	C-121535	Adapter - Switch Operating	1
6	B-121553	Switch Shaft Assy. (Incls. items #5, 7 & 12)	1
7	B-121550	Shaft - Switch	1
8	SC-41-86	Cap Screw - 1/4"-20 x 3/8" Hex Hd	2
9	SD-15-40	Self-Tapping Screw - #8-32 x 3/8" Phil. Pan Hd. "Taptite"	2
10	B-121547	Spring - Compression	1
11	PC-5-8	Cotter Pin - 3/32" x 5/8"	1
12	C-121540-2	Actuator - Switch	1
13	SD-15-40	Self-Tapping Screw - #8-32 x 3/8" Phil. Pan Hd. "Taptite"	2
14	WL-7-7	Lock Washer - #8 Ext. Shakeproof	2
15	C-123241-1	Bracket - Switch	1
16	B-121827	Ring - Locking	1
17	B-120388	Switch & Label Assy	1
18	C-108199-1	Clamp - Air Heater	1
19	C-121543	Shield - Heater	1
20	B-121926-1	Contactor Assy. (3 Pole, 220 V.)	1
21	B-121926-2	Contactor Assy. (3 Pole, 115 V.)	1
22	C-121544	Panel - Control Box (Upper)	1
23	C-121545	Cover - Switch Box	1
24	SD-32-13	Self-Tapping Screw - #8-16 x 1" Phil. Pan Hd. "Plastite"	6
25	B-121557	Grommet (Use with item #49)	1
26	SD-15-40	Self-Tapping Screw - #8-32 x 3/8" Phil. Pan Hd. "Taptite"	2
27	B-88196-6-1	Relay - Thermal Overload (1 Ph.) (W/Overload Protection)	1
28	B-88196-9-1	Relay - Thermal Overload (3 Ph.) (W/Overload Protection)	1
29	*	Heater Element - Overload Relay (W/Overload Protection)	AR
30	C-114707	Terminal & Mounting Board Assy. (380 V./415 V./460 V./Pilot Circuit)	1
31	SC-19-33	Mach. Screw - #8-32 x 1/2" Bind. Hd	2
32	WL-7-7	Lock Washer - #8 Ext. Shakeproof	2
33	NS-9-12	Mach. Nut - #8-32 Hex	2
34	SC-14-57	Mach. Screw - #10-24 x 1/2" Flat Hd	1
35	WL-3-20	Lock Washer - #10 Light	1
36	NS-9-22	Mach. Nut - #10-24 Hex	1
37	C-121533-1	Control Box Plate Assy. (Single)	1
38	C-121533-2	Control Box Plate Assy. (Dual)	1
39	SC-18-20	Mach. Screw - #10-24 x 1/2" Pan Hd	AR
40	WL-3-20	Lock Washer - #10 Light	AR
41	FE-19-48	Fuse (.8 Amp., 600 V.) (60 Hz.)	2
42	FE-16-29	Fuse (1 Amp., 600 V.) (50 Hz.)	2
43	B-120907	Transformer (60 Hz.)	1
44	B-120908	Transformer (50 Hz.)	1
45	SD-15-20	Self-Tapping Screw - #10-32 x 3/8" Phil. Pan Hd. "Taptite"	1
46	WL-7-12	Lock Washer - #10 Ext. Shakeproof	1
47	SD-15-20	Self-Tapping Screw - #10-32 x 3/8" Phil. Pan Hd. "Taptite"	2
48	WL-7-12	Lock Washer - #10 Ext. Shakeproof	1
49	D-121546-2	Box - Motor Control	1
50	C-121555	Panel - Control Box	1
51	SD-15-20	Self-Tapping Screw - #10-32 x 3/8" Phil. Pan Hd. "Taptite"	2
52	WL-7-12	Lock Washer - #10 Ext. Shakeproof	1
53	C-121545	Cover - Switch Box	1
54	SD-15-20	Self-Tapping Screw - #10-32 x 3/8" Phil. Pan Hd. "Taptite"	1
55	WL-7-12	Lock Washer - #10 Ext. Shakeproof	1
56	SD-32-13	Self-Tapping Screw - #8-16 x 1" Phil. Pan Hd. "Taptite"	6
57	SD-15-20	Self-Tapping Screw - #10-32 x 3/8" Phil. Pan Hd. "Taptite"	1
58	WL-7-12	Lock Washer - #10 Ext. Shakeproof	1
59	D-121546-1	Box - Motor Control	1
60	SD-15-20	Self-Tapping Screw - #10-32 x 3/8" Phil. Pan Hd. "Taptite"	2
61	WL-7-12	Lock Washer - #10 Ext. Shakeproof	1
62	B-122345-1	Heater Assy. (115 V.)	1
63	B-122345-2	Heater Assy. (220 V.)	1
64	SD-15-40	Self-Tapping Screw - #8-32 x 3/8" Phil. Pan Hd. "Taptite"	2
	C-112005	Gasket - Lid (Use with items #23 & 53) (Not Shown)	AR

*Give Elec. Spec. Mach. Model & Motor Type.

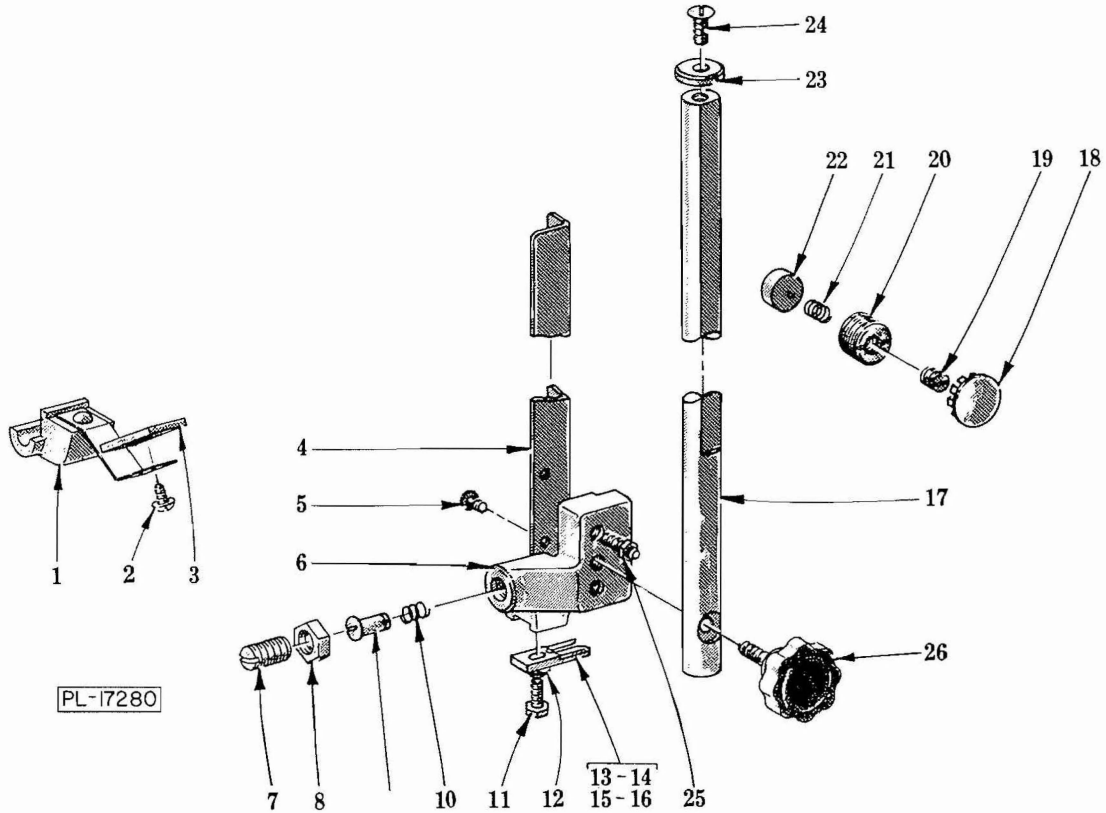

UPPER GUIDE, GUARD AND PULLEY WIPER UNIT

ILLUS. PL-17280	PART NO.	NAME OF PART	AMT.
1	B-102399	Upper Pulley Wiper Assy. (Incls. items #2 & 3)	1
2	SC-53-1	Mach. Screw - #10-24 x 1/4" Truss Hd	2
3	B-123886	Wiper - Upper Pulley	1
4	C-120443-2	Guard - Upper Blade	1
5	SC-53-5	Mach. Screw - #10-24 x 3/8" Truss Hd	2
6	B-113863	Upper Guide Support & Bushing Assy	1
7	SC-49-22	Set Screw - 9/16"-18 x 7/8" Hdls., Flat Pt	1
8	NS-18-33	Jam Nut - 9/16"-18 Hex Fin	1
9	M-101924	Blade Back-Up Block Assy	1
10	M-101925	Spring - Back-Up Block	1
11	SC-67-6	Mach. Screw - #10-24 x 1/2" Trimmed Hex Hd	1
12	A-104573	Washer - Belleville	1
13	P-101929-4	Guide - Blade (.020" Blade)	1
14	P-101929-2	Guide - Blade (.014" Blade)	1
15	P-101929-1	Guide - Blade (.026" Blade)	1
16	P-101292-3	Guide - Blade (.038" Blade)	1
17	B-102321-4	Rod - Slide	1
18	PB-2-26	Plug - Button	1
19	SC-63-33	Set Screw - 3/8"-16 x 3/8" Hdls., Flat Pt	1
20	B-120140	Screw - Slide Rod Adjusting	1
21	M-75866	Spring - Slide Rod Adjusting	1
22	B-120141	Shoe - Slide Rod	1
23	M-69849	Stop - Slide Rod	1
24	SC-53-16	Mach. Screw - 5/16"-18 x 5/8" Truss Hd	1
25	A-102322	Screw - Adjusting	2
26	C-120444-1	Knob - Positioning	1
	C-113850-5	Upper Guide & Guard Assy. (.020" Blade) (Incls. items #4 thru 13 & 25)	1
	C-113850-6	Upper Guide & Guard Assy. (.014" Blade) (Incls. items #4 thru 12, 14 & 25)	1