



CATALOG OF REPLACEMENT PARTS



6614 MEAT SAW

ML-134050

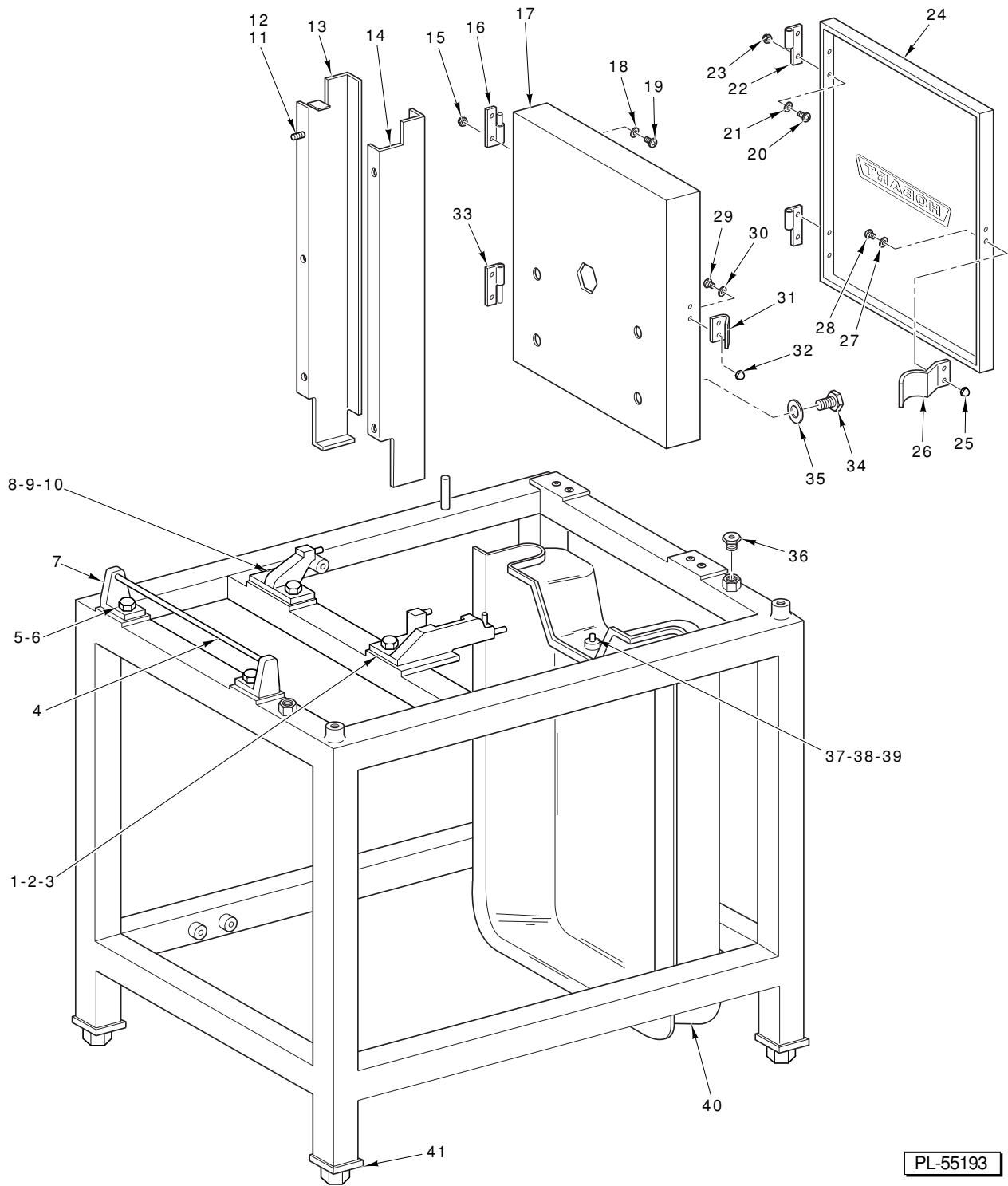

FRAME AND COVER

PL-55193

FRAME AND COVER

ILLUS. PL-55193	PART NO.	NAME OF PART	AMT.
1	00-291653	Lower Guide Support & Pin Assy	1
2	SC-041-31	Cap Screw $\frac{3}{8}$ -16 x 1 $\frac{1}{4}$ Hex Hd	2
3	WS-018-40	Washer	2
4	00-290758-00003	Rod - Anchor (Left Table)	1
5	SC-041-31	Cap Screw $\frac{3}{8}$ -16 x 1 $\frac{1}{4}$ Hex Hd	2
6	WS-018-40	Washer	2
7	00-290751	Support - Left Table	2
8	00-290752	Table Lock & Pin Assy.	1
9	SC-041-31	Cap Screw $\frac{3}{8}$ -16 x 1 $\frac{1}{4}$ Hex Hd	2
10	WS-018-40	Washer	2
11	SC-093-07	Mach. Screw 10-32 x $\frac{1}{2}$ Pan Hd.	3
12	WL-006-07	Lockwasher #10 Medium	3
13	00-875087	Guard - Column	1
14	00-875088	Guard - Removable	1
15	NS-046-33	Acorn Nut 6-32 Hex	4
16	00-437676	Hinge - Bottom (W/Short Pin)	1
17	00-875112	Upper Baffle Assy. (Incls. Items 16 thru 20 & 30 thru 33)	1
18	WS-028-03	Washer	4
19	SC-021-08	Mach. Screw 6-32 x $\frac{3}{8}$ Rd. Hd. (SST)	4
20	SC-021-08	Mach. Screw 6-32 x $\frac{3}{8}$ Rd. Hd. (SST)	4
21	WS-028-03	Washer	4
22	00-437378-00002	Hinge - Lift Off (Top W/O Pin)	2
23	NS-046-33	Acorn Nut 6-32 Hex	4
24	00-875111	Upper Cover Assy. (Incls. Items 22 thru 29)	1
25	NS-046-33	Acorn Nut 6-32 Hex	2
26	00-291502	Clip - Latch	1
27	WS-028-03	Washer	2
28	SC-021-07	Mach. Screw 6-32 x $\frac{1}{4}$ Rd. Hd. Slotted	2
29	SC-021-07	Mach. Screw 6-32 x $\frac{1}{4}$ Rd. Hd. Slotted	2
30	WS-028-03	Washer	2
31	00-437608	Clip - Cover Retainer	1
32	NS-046-33	Acorn Nut 6-32 Hex	2
33	00-437378-00003	Hinge - Lift Off (Bottom W/Pin)	1
34	SC-041-50	Cap Screw $\frac{1}{4}$ -20 x $\frac{1}{2}$ Hex Hd.	4
35	WS-003-47	Washer	4
36	00-875054	Screw - Jack	2
37	00-290860	Anchor - Lower Cover	1
38	SC-041-05	Cap Screw $\frac{1}{4}$ -20 x $\frac{5}{8}$ Hex Hd.	1
39	WS-003-47	Washer	1
40	00-875040	Lower Cover W/Molded Handle	1
41	00-435792	Foot (2" to 4" Adjustable Height)	4

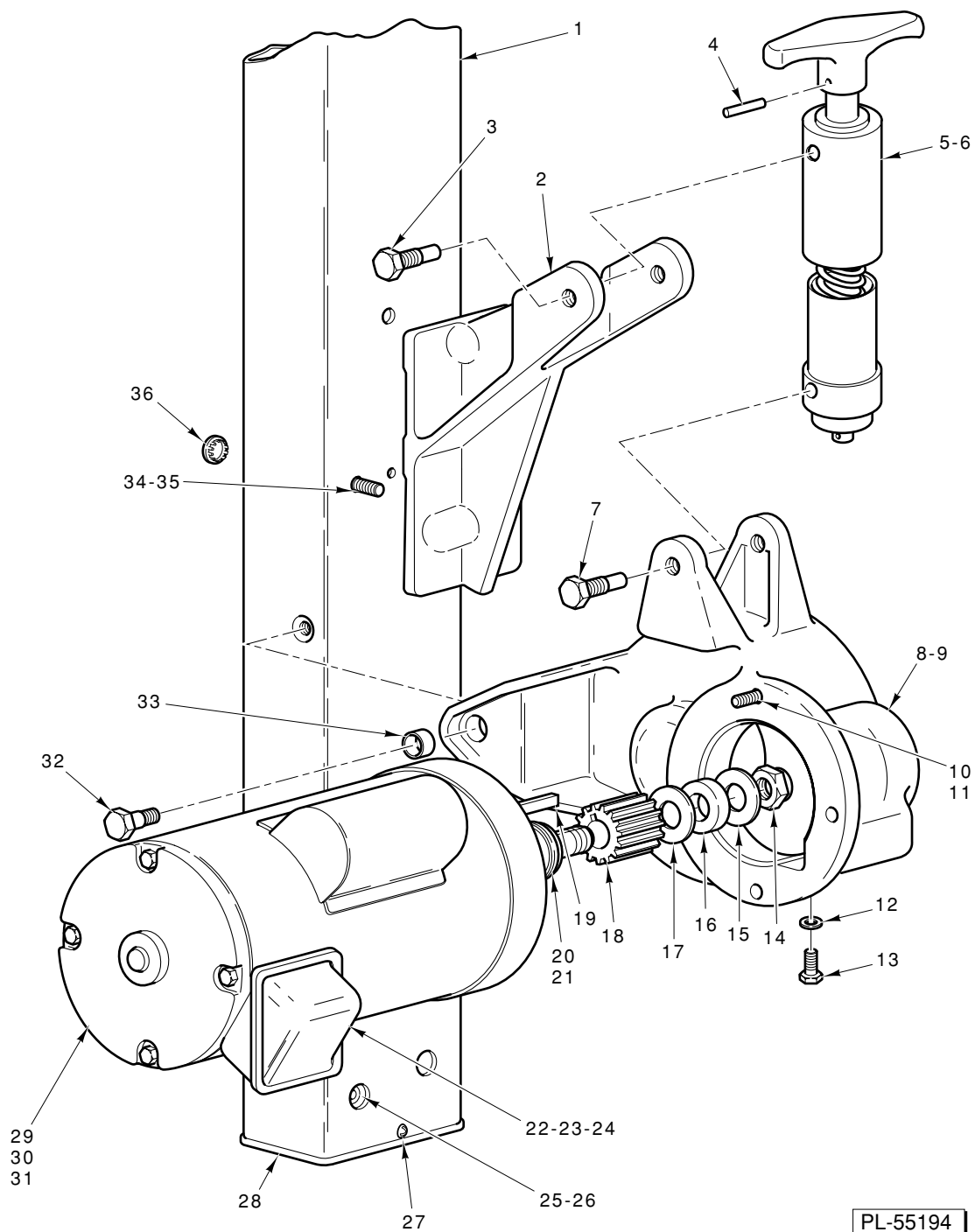

PL-55194

DRIVE AND TENSION ADJUSTMENT UNIT

DRIVE AND TENSION ADJUSTMENT UNIT

ILLUS. PL-55194	PART NO.	NAME OF PART	AMT.
1	00-875063	Column & Label Assy.	1
2	00-875047-00002	Transmission Support Assy.	1
3	00-290832	Pivot - Tension Adjusting	2
4	RP-003-16	Roll Pin ³ / ₁₆ x 1 Lg.	1
5	00-873500	Tensioner Assy. (Incls. Items 4 & 6)	1
6	BN-005-06	Needle Bearing - Torrington NTA-1018	1
7	00-290832	Pivot - Tension Adjusting	2
8	00-120971	Plug - Vent	1
9	00-875137	Gear Case Assy. (Incls. Items 8 & 33)	1
10	SC-041-31	Cap Screw ³ / ₈ -16 x 1 ¹ / ₄ Hex Hd	3
11	WL-019-85	Lockwasher	3
12	WS-021-20	Washer	1
13	SC-036-93	Cap Screw ⁷ / ₁₆ -20 x ³ / ₄ Hex Hd.	1
14	NS-046-29	Lock Nut ³ / ₄ -16 Flexlox	1
15	SL-005-02	Spring - Loading	1
16	00-290866	Washer - Damper	1
17	SL-005-02	Spring - Loading	1
18	00-875043	Pinion - Drive	1
19	00-109070-00008	Key	1
20	SL-005-02	Spring - Loading	2
21	00-290866	Washer - Damper	1
22	SC-027-29	Mach. Screw 8-32 x ³ / ₈ Rd. Hd.	AR
23	WL-010-01	Lockwasher 8 External Shakeproof	AR
24	NS-010-11	Mach. Nut 8-32 Hex (Brass)	AR
25	SC-040-21	Cap Screw ³ / ₈ -16 x ⁷ / ₈ Soc. Hd.	4
26	WL-004-06	Lockwasher ³ / ₈ Medium	4
27	SD-038-03	Self - Tapping Screw 10-16 x ³ / ₄ Truss Hd.	2
28	00-479134	End Cap	1
29	00-437301-00001	Motor (60 Hz.) (3 Ph.)	1
30	00-437301-00003	Motor (50 Hz.) (3 Ph.)	1
31	00-479005	Motor (1 Ph.)	1
32	00-873986	Screw Shoulder	2
33	00-291859-00002	Bushing 3/8 Lg.	2
34	SC-040-21	Cap Screw ³ / ₈ -16 x ⁷ / ₈ Soc. Hd.	5
35	WS-018-04	Washer	5
36	PB-004-92	Plug Button	13
	00-875114-00001	Motor & Pinion Assy. (60 Hz. 3 Phase)(Incls. Items 14 thru 21 & 28)	1
	00-875114-00002	Motor & Pinion Assy. (50 Hz. 3 Phase)(Incls. Items 14 thru 21 & 29)	1
	00-875114-00003	Motor & Pinion Assy. (60 Hz. 1 Phase)(Incls. Items 14 thru 21 & 30)	1

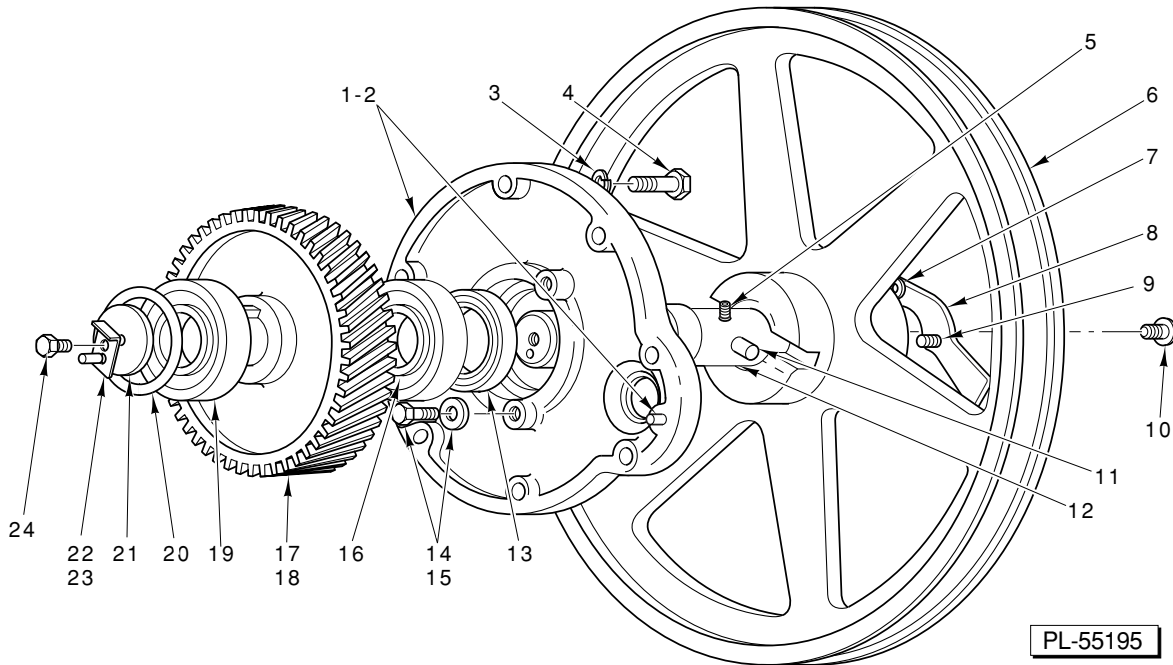

LOWER PULLEY UNIT

LOWER PULLEY UNIT

ILLUS. PL-55195	PART NO.	NAME OF PART	AMT.
1	00-290817-00002	Gear Case Cover Assy. (Incls. Item 2)	1
2	00-011800-00091	Dowel	2
3	WL-006-22	Lockwasher ⁵ / ₁₆ Light	7
4	SC-041-15	Cap Screw ⁵ / ₁₆ -18 x 1 ¹ / ₄ Hex Hd.	7
5	SC-119-20	Set Screw ¹ / ₄ -20 x ¹ / ₂ Soc. Hdls., Flat Pt.	1
6	ML-109658-0000Z	Pulley & Latch Assy. (Incls. Items 7, 8 & 9)	1
7	00-079686	Catch - Friction	1
8	00-875150	Latch	1
9	00-020851	Screw - Latch	1
10	SD-005-49	Self-Tapping screw 12 x ¹ / ₂ Rd. Hd. Type U	1
11	00-436447	Pin - Drive	1
12	00-875060	Shaft - Lower	1
13	00-290805	Seal - Shaft	1
14	SC-036-24	Cap Screw ⁵ / ₁₆ -18 x ⁵ / ₈ Hex Hd.	3
15	WS-018-40	Washer	3
16	BB-008-14	Ball Bearing - ND 77207	1
17	00-875044-00002	Gear - Drive (56T)	1
18	00-109070-00009	Key	1
19	BB-008-14	Ball Bearing - ND 77207	1
20	SL-003-11	Spring - Loading ND 72	2
21	00-291973	Retainer - Shaft	1
22	00-291624	Retainer - Lock	1
23	RP-003-18	Roll Pin ¹ / ₈ x ⁷ / ₈ Lg.	1
24	SC-041-13	Cap Screw ⁵ / ₁₆ -18 x 1 Hex Hd. SST	1
	00-875138	Drive Unit - Lower (Incls. Items 5, 10, 11, 12, 16 thru 19 & 21 thru 24)	1

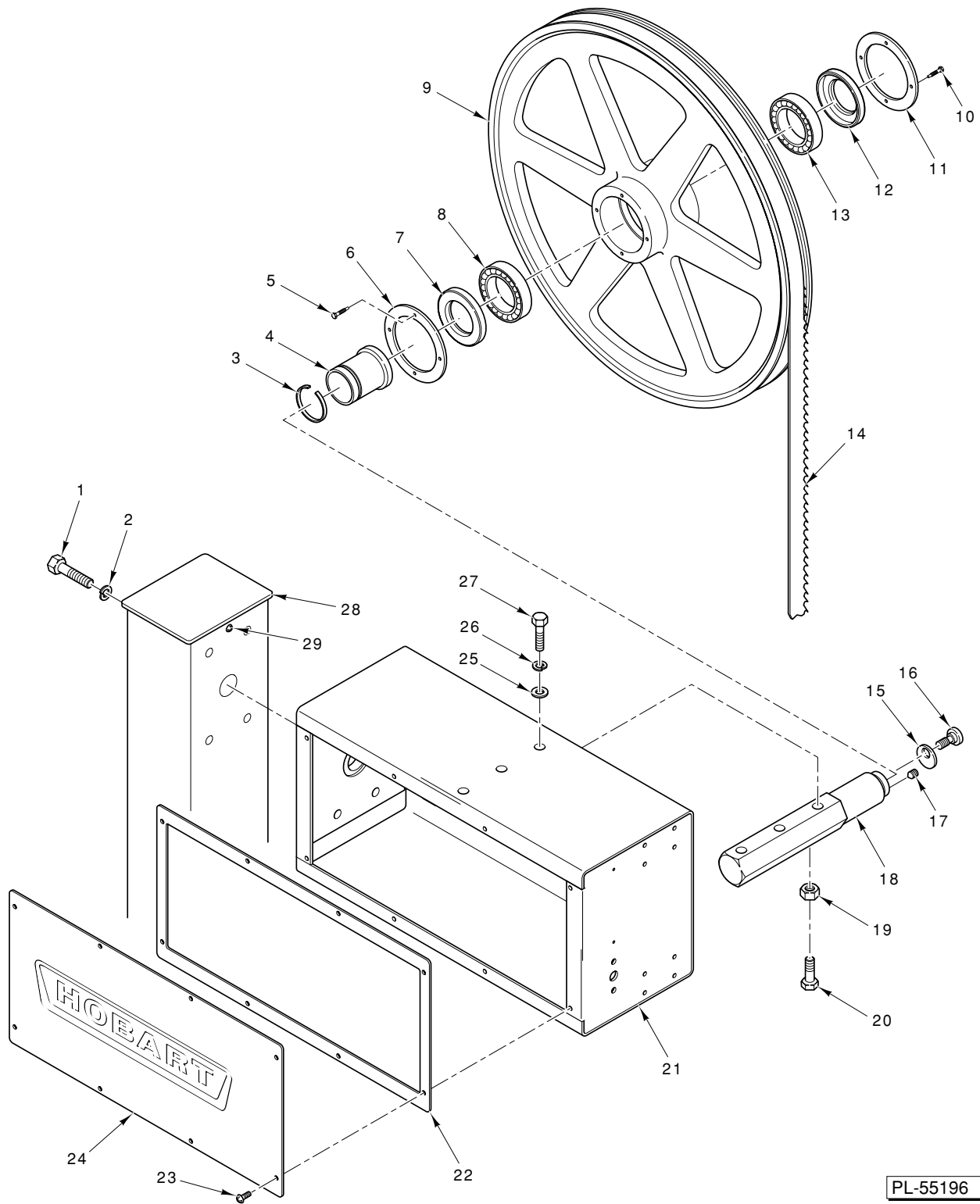

PL-55196

UPPER BEARING CARRIER UNIT

UPPER BEARING CARRIER UNIT

ILLUS. PL-55196	PART NO.	NAME OF PART	AMT.
1	SC-040-21	Cap Screw $\frac{3}{8}$ -16 x $\frac{7}{8}$ Soc. Hd.	4
2	WL-004-06	Lockwasher $\frac{3}{8}$ Medium	4
3	RR-004-13	Retaining Ring (Truarc)	1
4	00-479143	Bushing - Pulley	1
5	SC-067-06	Mach. Screw 10-24 x $\frac{1}{2}$ Hex Hd.	4
6	00-873461-00002	Cover - Rear Pulley	1
7	00-873501	Seal - Shaft	1
8	BB-015-36	Ball Bearing - Hoover - NSK 6007 DDUCE1SRIS	1
9	ML-134048-0000Z	Pulley Assy. - Upper (Packaged)	1
10	SC-067-06	Mach. Screw 10-24 x $\frac{1}{2}$ Hex Hd.	4
11	00-873461-00001	Cover - Front Pulley	1
12	00-873502	Seal - Shaft	1
13	BB-015-36	Ball Bearing - Hoover - NSK 6007 DDUCE1SRIS	1
14	00-477016-00126	Blade - Meat Saw	1
15	00-479142	Retainer - Pulley	1
16	00-020851	Screw - Latch	1
17	00-079686	Catch - Friction	1
18	00-479144	Shaft - Upper	1
19	NS-018-14	Jam Nut $\frac{3}{8}$ -16 Hex	2
20	SC-127-03	Cap Screw - $\frac{3}{8}$ -16 x 1 $\frac{3}{4}$ Hex Hd.	2
21	00-875072	Box Column Assy.	1
22	00-875080	Gasket - Column Box	1
23	SC-025-33	Mach. Screw 8-32 x $\frac{1}{2}$ Binding Hd.	8
24	00-875077	Cover - Column Box	1
25	WS-018-40	Washer	3
26	WL-006-27	Lockwasher $\frac{3}{8}$ Light	3
27	SC-041-31	Cap Screw $\frac{3}{8}$ -16 x 1 $\frac{1}{4}$ Hex Hd	3
28	00-479134	End Cap	1
29	SD-038-03	Self - Tapping Screw 10-16 x $\frac{3}{4}$ Truss Hd.	2

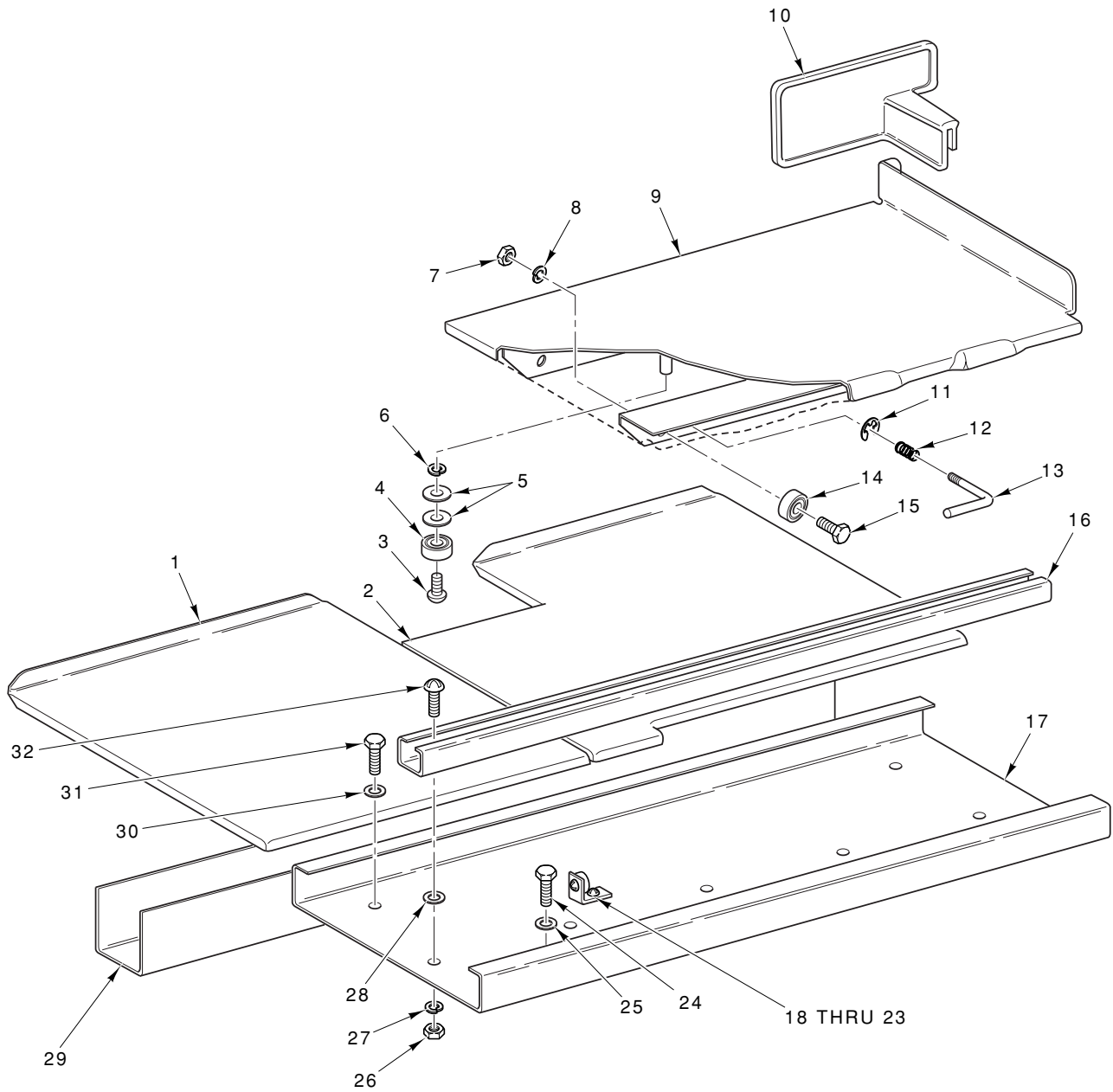

PL-55197

TABLES AND CARRIAGE UNIT

TABLES AND CARRIAGE UNIT

ILLUS. PL-55197	PART NO.	NAME OF PART	AMT.
1	00-875066	Table - Left Assy.	1
2	00-875068	Table - Right Assy.	1
3	SC-041-30	Cap Screw $\frac{3}{8}$ -16 x 1 Hex Hd. SST	2
4	BB-008-11	Ball Bearing - Nice #8220-TN	2
5	WS-018-30	Washer	4
6	WL-006-28	Lockwasher $\frac{3}{8}$ Medium	2
7	NS-046-09	Stop Nut $\frac{3}{8}$ -16 Elastic	4
8	WS-018-34	Washer - Shim .010" THK.	4
9	00-875096	Carriage Assy.	1
10	00-291435	Pusher Plate	1
11	RR-011-09	Retaining Ring	2
12	00-290787	Spring - Carriage Lock	1
13	00-290795	Lever - Carriage Lock	1
14	BB-008-11	Ball Bearing - Nice #8220-TN	4
15	SC-041-30	Cap Screw $\frac{3}{8}$ -16 x 1 Hex Hd. SST	4
16	00-875089	Guide - Roller	1
17	00-875091	Support - Carriage	1
18	00-479107	Stop - Carriage	2
19	SC-124-44	Bolt - Sq. Neck $\frac{5}{16}$ -18 x $\frac{3}{4}$ Rd. Hd.	2
20	WS-018-34	Washer - Shim .010" THK.	2
21	00-070087	Washer - Spring	2
22	NS-031-29	Stop Nut $\frac{5}{16}$ -18 "Elastic"	2
23	00-873789	Bumper - Carriage Stop	2
24	SC-041-29	Cap Screw $\frac{3}{8}$ -16 x $\frac{7}{8}$ Hex Hd., Wax Coated Threads	2
25	WS-018-40	Washer	2
26	NS-015-11	Nut $\frac{5}{16}$ -18 Hex	5
27	WL-006-23	Lockwasher $\frac{5}{16}$ Medium (SST)	5
28	WS-017-21	Washer	5
29	00-875065	Tray - Scrap	1
30	WS-018-40	Washer	2
31	SC-041-34	Cap Screw $\frac{3}{8}$ -16 x 2 Hex Hd.	2
32	SC-124-44	Bolt - Sq. Neck $\frac{5}{16}$ -18 x $\frac{3}{4}$ Rd. Hd.	5

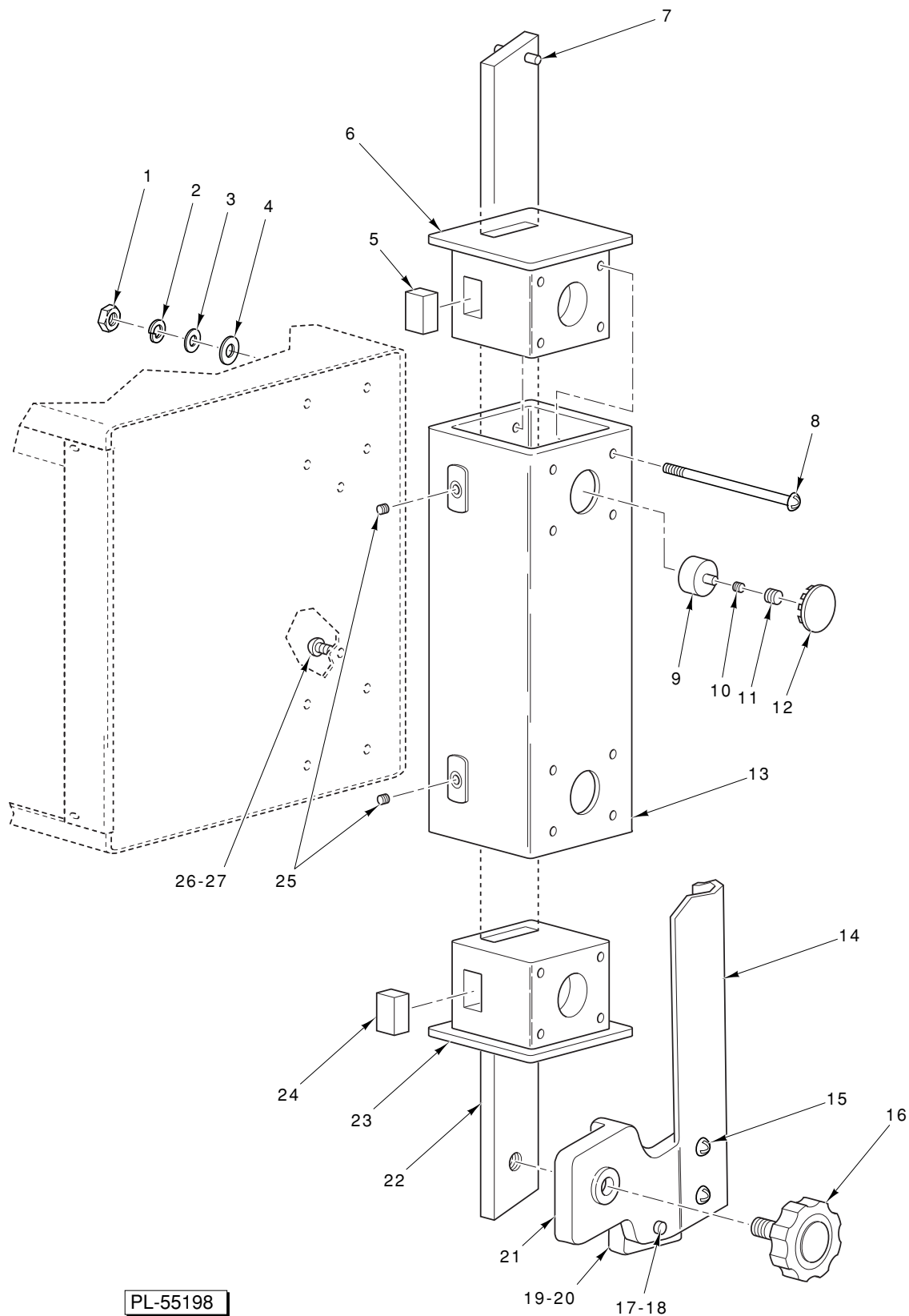

PL-55198

UPPER GUIDE UNIT

UPPER GUIDE UNIT

ILLUS. PL-55198	PART NO.	NAME OF PART	AMT.
1	NS-011-12	Mach. Nut 8-32 Hex	8
2	WL-014-05	Lockwasher #8 External Shakeproof	8
3	WS-023-22	Washer	8
4	WS-031-35	Washer	8
5	00-479766	Slide Lock	1
6	00-478999	Guide Bar Insert	1
7	PG-007-16	Groove Pin $\frac{3}{16}$ Dia. x $\frac{3}{4}$ Lg.	1
8	SC-021-17	Mach. Screw 8-32 x 2 $\frac{1}{2}$ Rd. Hd.	8
9	00-120141	Shoe - Slide Rod	2
10	00-873782	Spring - Slide Rod	2
11	SC-046-70	Set Screw $\frac{3}{8}$ -16 x $\frac{1}{2}$ Hdls., Cup Pt.	2
12	PB-005-09	Plug Button	2
13	00-478998	Support - Guide Bar	1
14	00-875056	Guard - Front Blade	1
15	SC-053-05	Mach. Screw 10-24 x $\frac{3}{8}$ Truss Hd., Slotted	2
16	00-435958-00002	Knob - Adjusting	1
17	SC-041-02	Cap Screw $\frac{1}{4}$ -20 x 1 Hex Hd. (Lower Guide)	1
18	00-291579	Washer - Guide	1
19	00-290844-00001	Guide - Saw Blade (.022" Blade)	1
20	00-290844-00002	Guide - Saw Blade (.014" Blade)	1
21	00-290842	Holder - Upper Guide	1
22	00-873204	Upper Guide Support Bar Assy. (Incls. Item 4)	1
23	00-478999	Guide Bar Insert	1
24	00-479766	Slide Lock	1
25	SC-055-01	Set Screw 10-24 x $\frac{1}{4}$ Soc. Hdls. Cup Pt. SST	2
26	SC-025-33	Mach. Screw 8-32 x $\frac{1}{2}$ Binding Hd.	2
27	NS-011-12	Mach. Nut 8-32 Hex	2

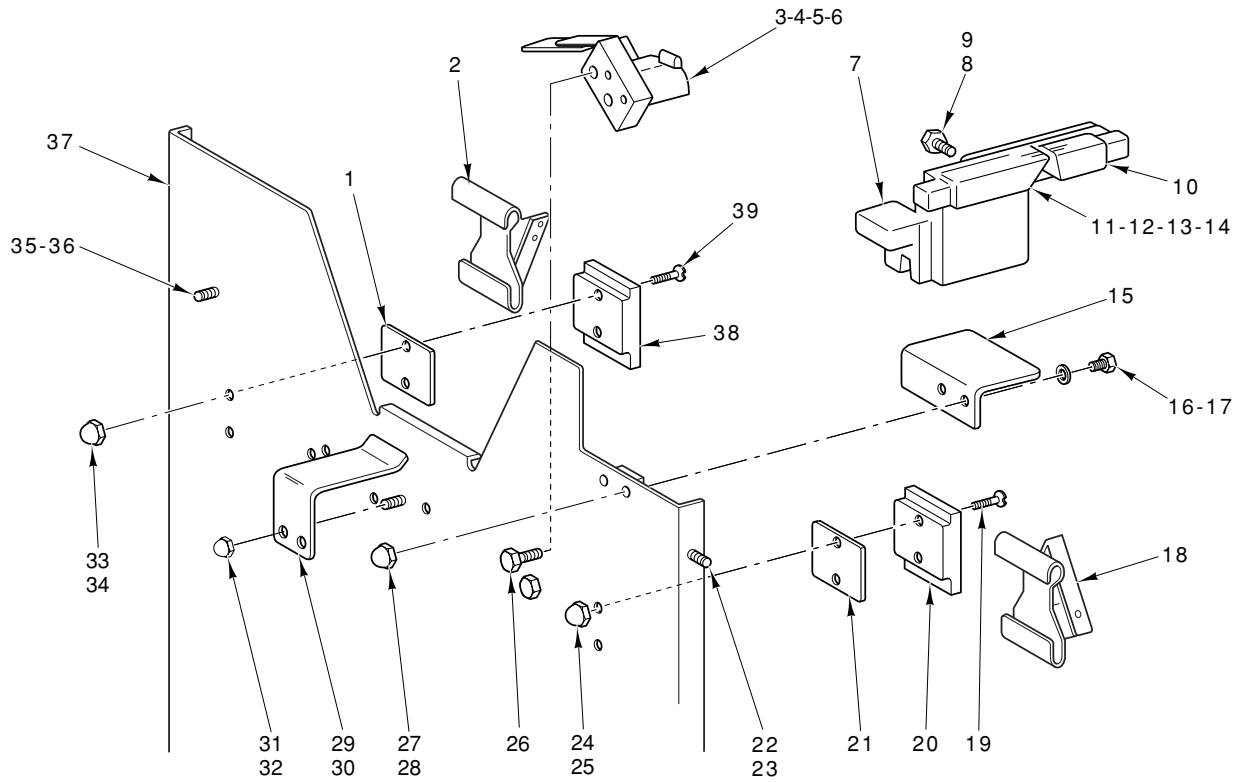

PL-55199

LOWER WIPER UNIT

LOWER WIPER UNIT

ILLUS. PL-55199	PART NO.	NAME OF PART	AMT.
1	00-290855	Shim - Wiper Support.....	AR
2	00-290798	Blade Wiper Assy.....	1
3	00-291831	Block - Pulley Wiper.....	1
4	00-102399	Pulley Wiper Assy. (Incls. Items 5 & 6).....	1
5	00-123886	Wiper - Pulley.....	1
6	SC-053-01	Mach. Screw 10-24 x 1/4 Truss Hd.	2
7	00-875234-00002	Holder - Lower Guide.....	1
8	00-875235	Cover - Guide.....	1
9	SC-116-26	Cap Screw 1/4-28 x 7/8 Hex Hd.	2
10	00-291658	Guide - Plastic.....	1
11	00-291670-00001	Guide - Saw Blade (.022" Blade).....	1
12	00-291670-00002	Guide - Saw Blade (.014" Blade).....	1
13	00-291670-00003	Guide - Saw Blade (.038" Blade).....	1
14	00-291670-00004	Guide - Saw Blade (.020" Blade).....	1
15	00-875246	Support.....	1
16	SC-041-50	Cap Screw 1/4-20 x 1/2 Hex Hd.	2
17	WS-003-49	Washer.....	2
18	00-290798	Blade Wiper Assy.....	1
19	SC-022-35	Mach. Screw 1/4-20 x 1 Flat Hd.	4
20	00-290822	Support - Wiper.....	2
21	00-290855	Shim - Wiper Support.....	0
22	SC-041-50	Cap Screw 1/4-20 x 1/2 Hex Hd.	2
23	WS-003-49	Washer.....	2
24	NS-025-04	Acorn Nut 1/4-20.....	4
25	WS-003-49	Washer.....	4
26	SC-041-50	Cap Screw 1/4-20 x 1/2 Hex Hd.	2
27	WL-006-17	Lockwasher 1/4 Medium.....	2
28	NS-025-04	Acorn Nut 1/4-20.....	2
29	00-290788	Clip - Cover.....	1
30	SC-025-07	Mach. Screw 10-24 x 5/16 Bind. Hd.	2
31	NS-025-01	Nut - Crown 10-24.....	2
32	WL-006-06	Lockwasher #10 Light.....	2
33	NS-025-04	Acorn Nut 1/4-20.....	4
34	WS-003-49	Washer.....	4
35	SC-041-50	Cap Screw 1/4-20 x 1/2 Hex Hd.	2
36	WS-003-47	Washer.....	2
37	00-875082	Baffle - Lower Pulley.....	1
38	00-290822	Support - Wiper.....	2
39	SC-022-35	Mach. Screw 1/4-20 x 1 Flat Hd.	4
40	00-291809	Shield - Blade Guide.....	1
	00-291672-00001	Holder & Guide Assy. (Incls. Items 7 thru 10 & 11).....	1
	00-291672-00002	Holder & Guide Assy. (Incls. Items 7 thru 10 & 12).....	1
	00-291672-00003	Holder & Guide Assy. (Incls. Items 7 thru 10 & 13).....	1
	00-291672-00004	Holder & Guide Assy. (Incls. Items 7 thru 10 & 14).....	1

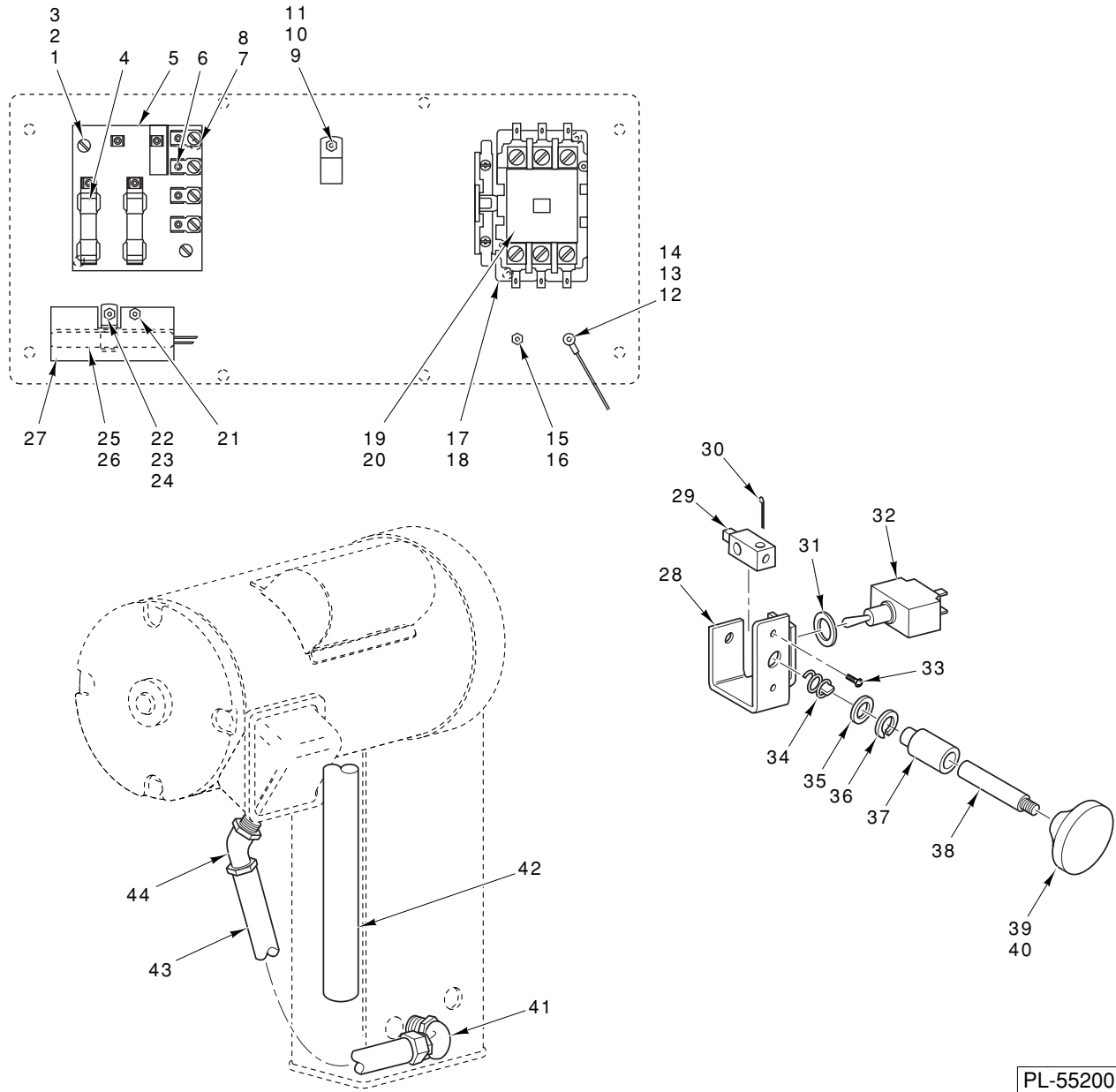

PL-55200

ELECTRICAL UNIT

ELECTRICAL UNIT

ILLUS. PL-55200	PART NO.	NAME OF PART	AMT.
1	SC-025-33	Mach. Screw 8-32 x 1/2 Binding Hd.	2
2	WL-014-05	Lockwasher #8 External Shakeproof	2
3	NS-011-12	Mach. Nut 8-32 Hex	2
4	FE-019-48	Fuse (8/10 AMPS.) (600 V.)	2
5	00-120907-00001	Transformer (60 Hz.)	1
6	00-114707	Fuse Board	1
7	NS-011-12	Mach. Nut 8-32 Hex	2
8	WL-014-05	Lockwasher #8 External Shakeproof	2
9	NS-011-12	Mach. Nut 8-32 Hex	1
10	WS-023-22	Washer	1
11	00-078752-00009	Clamp - Cable	1
12	00-290889	Cable & Eyelet Assy. (Panel to Column)	1
13	NS-011-12	Mach. Nut 8-32 Hex	2
14	WL-014-05	Lockwasher #8 External Shakeproof	2
15	NS-011-12	Mach. Nut 8-32 Hex	1
16	WL-014-05	Lockwasher #8 External Shakeproof	1
17	NS-011-12	Mach. Nut 8-32 Hex	2
18	WL-014-05	Lockwasher #8 External Shakeproof	2
19	00-087713-101-1	Contactory Assy. (3 Pole) (200-230 V.)	1
20	00-087713-101-2	Contactory Assy. (3 Pole) (460 V.)	1
21	NS-011-12	Mach. Nut 8-32 Hex	1
22	NS-011-12	Mach. Nut 8-32 Hex	1
23	WS-023-22	Washer	1
24	00-108199-00001	Clamp - Air Heater	1
25	00-122345-00001	Heater Assy (460 V)	1
26	00-122345-00002	Heater Assy (200-230 V)	1
27	00-121543	Shield - Heater	1
28	00-123241-00001	Bracket - Switch	1
29	00-873781	Actuator Switch	1
30	PC-005-08	Cotter Pin 3/32 x 5/8 Lg.	1
31	00-121827	Ring - Locking	1
32	00-120388	Switch & Label Assy.	1
33	SC-010-36	Mach. Screw 10-24 x 5/8 Truss Hd.	2
34	00-121547	Spring - Compression	1
35	00-875049	Retaining Ring	1
36	WS-018-30	Washer	1
37	00-290883	Bushing - Switch Shaft	1
38	00-290882	Shaft - Switch	1
39	00-291475	Label - Start/Stop	1
40	00-290885	Knob - Switch	1
41	FE-024-61	Connector 1/2 x 45 Deg.(Non Metallic)"Sealtite"	1
42	00-291600	Tube - Insulator	1
43	00-436913-00012	Conduit - 1/2 Liquidtite	1
44	FE-024-61	Connector 1/2 x 45 Deg.(Non Metallic)"Sealtite"	1

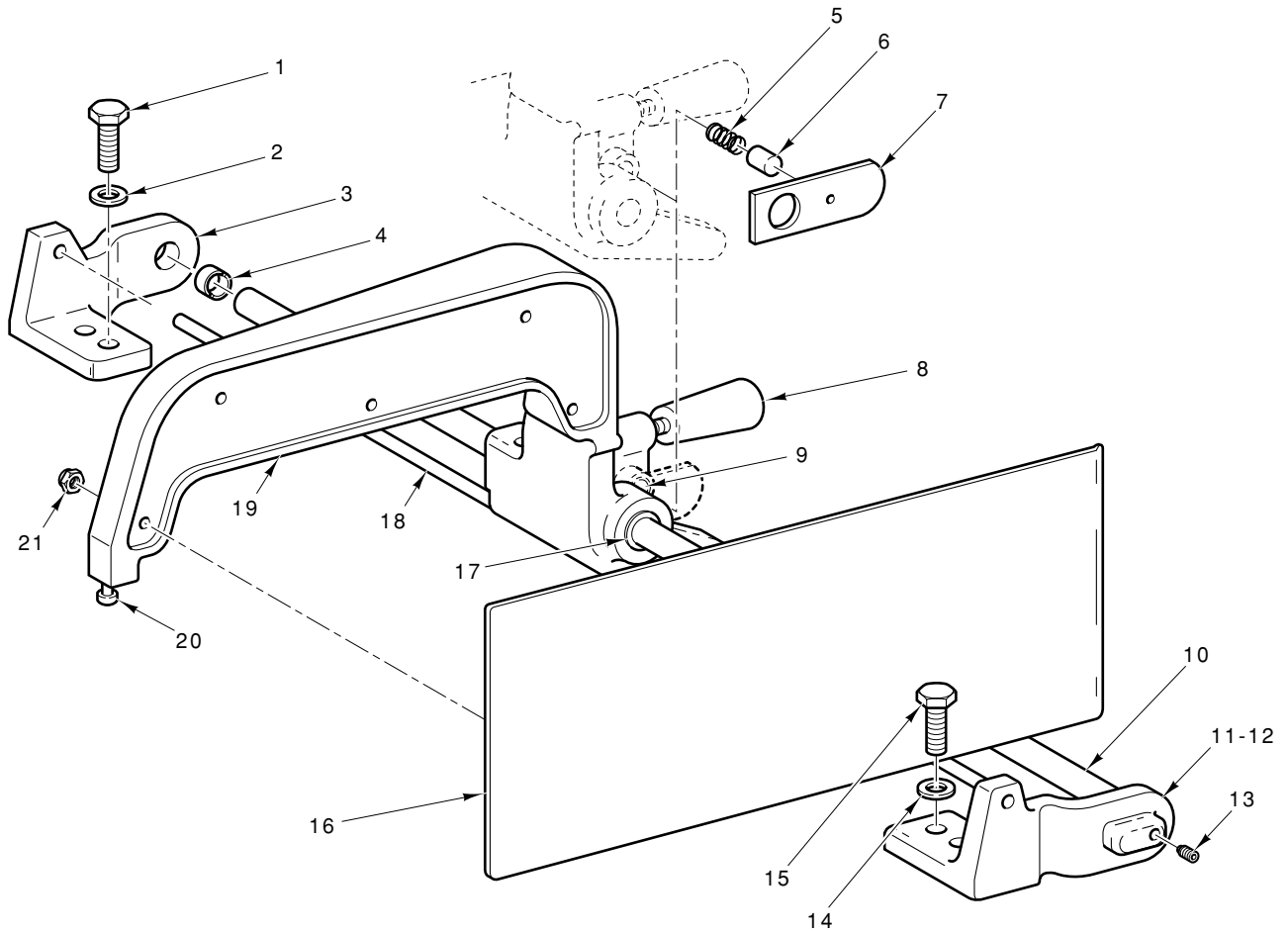

PL-55201

GUAGE PLATE UNIT

GUAGE PLATE UNIT

ILLUS. PL-55201	PART NO.	NAME OF PART	AMT.
1	SC-041-31	Cap Screw $\frac{3}{8}$ -16 x 1 $\frac{1}{4}$ Hex Hd	2
2	WS-018-40	Washer	2
3	00-290757	Support - Shaft & Rod (Rear)	1
4	00-479644	Bearing - Sleeve	2
5	00-291933	Spring - Gauge Plate Lock	1
6	00-291932	Pin - Locking Lever	1
7	00-290769	Lever - Locking	1
8	00-070194	Handle - Gauge Plate	1
9	00-110544-00010	Bushing - Gauge Plate Frame	1
10	00-290770-00003	Shaft - Gauge Plate	1
11	00-290792	Front Shaft & Rod Support Assy. (Incls. Items 12 & 13)	1
12	PG-006-11	Pin - Groove - $\frac{1}{4}$ x $\frac{5}{8}$, Type D	1
13	SC-064-27	Set Screw $\frac{5}{16}$ -18 x $\frac{1}{2}$ Soc. Hdls., Cup Pt. "Nylok"	1
14	WS-018-40	Washer	2
15	SC-041-31	Cap Screw $\frac{3}{8}$ -16 x 1 $\frac{1}{4}$ Hex Hd	2
16	00-291431	Plate and Stud Assy.	1
17	00-110544-00009	Bushing - Gauge Plate Frame	2
18	00-290758-00004	Rod - Table Anchor (Right Table)	1
19	00-291944	Gauge Plate Assy. (Incls. Items 9, 16, 17, 20 & 21)	1
20	00-290764	Button - Glide	1
21	NS-025-04	Acorn Nut $\frac{1}{4}$ -20	5
	00-292347	Gauge Plate Assy. (Incls. Items 5, 6, 7, 16, 19 & 20) (Pkgd.)	1

NOTES