

ASSEMBLY INSTRUCTIONS

MIXER TABLE ML-19504

FOR A120 or A200 MIXERS

This instruction describes the assembly and lists the parts needed for the mixer table.

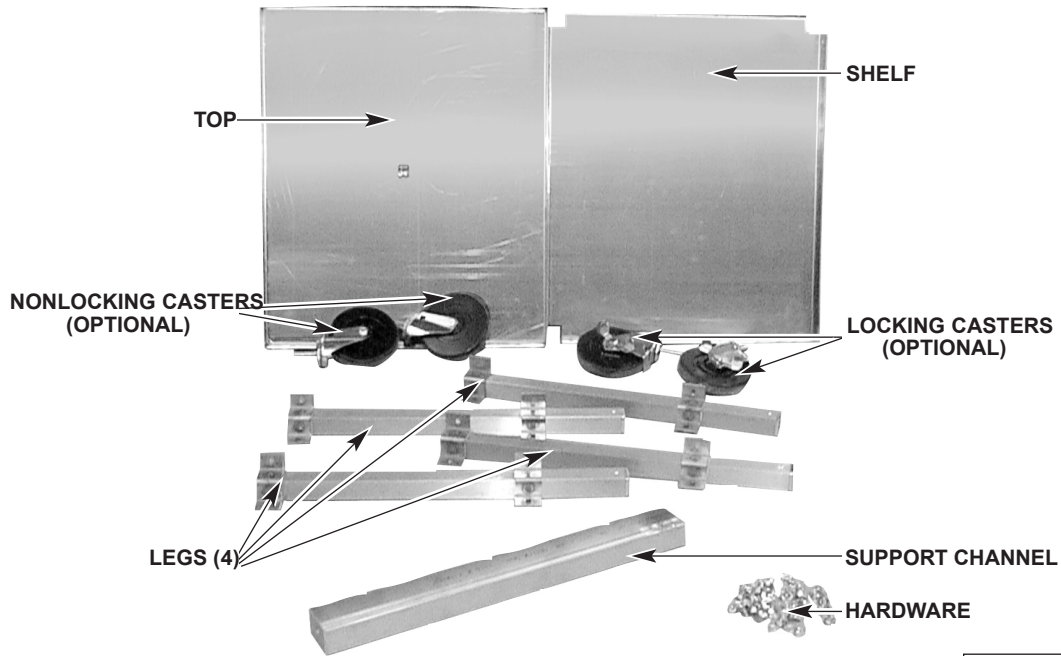

PL-41648-1

Description	Qty.
Top	1
Support Channel	1
Screw	18
Washer	18
Nut	18
Leg	4
Shelf	1
Feet (Set of 4) Not Shown	1
Casters Set (Optional - 2 Locking, 2 Nonlocking)	1
A120/200 Template (F-16965) Not Shown	1
Screw	4
Lockwasher	4



701 S. RIDGE AVENUE
TROY, OHIO 45374-0001

937 332-3000

www.hobartcorp.com

MIXER TABLE ML-19504 (cont)

1. Remove all protective film from top and shelf.
 2. Lay top facedown on flat surface. Install support channel to underside of top with (2) $\frac{1}{4}$ -20 x $\frac{1}{2}$ " screws, washers and nuts.
 3. Attach (4) legs to underside of top with eight $\frac{1}{4}$ -20 x $\frac{1}{2}$ " screws, washers and nuts.
 4. Angle shelf between legs and install on leg brackets using eight $\frac{1}{4}$ -20 x $\frac{1}{2}$ " screws, washers and nuts.
 5. Install feet (or optional casters) into bottom of legs.
 6. Turn table over so it is resting on feet/casters and top is up.
- NOTICE** If using optional casters, proceed to steps 7 & 8
7. Apply mixer template to top of table and punch, drill, & deburr according to the hole pattern on your mixer.
 8. Use $\frac{3}{8}$ -16 x $\frac{3}{4}$ screws & $\frac{3}{8}$ lockwashers to bolt down mixer to table.

NOTICE All components must be assembled prior to use.



(OPTIONAL CASTERS SHOWN)