



CATALOG OF REPLACEMENT PARTS



AWS-2 ACCESS WRAPPING SYSTEM

ML-44230
ML-44231
ML-44233
ML-44234

AWS-2 (L-R)
AWS-2 (R-L)
AWS-2C (L-R)
AWS-2C (R-L)

Table of Contents

7	RUN AND STOP SWITCH
9	CONTROL BOX
11	UPPER AND SIDE PANELS
13	LOWER AND SIDE PANELS
15	CANOPY AND REAR PANELS
17	SCALE PLATFORM
19	PRIMARY INTAKE AND SHIFTER
21	PRIMARY INTAKE SHIFT CONVEYOR AREA
23	INTAKE FRAME
25	CAMERA ENCLOSURE
27	ELEVATOR CONVEYOR ASSEMBLY
29	ELEVATOR MOTOR
31	ELEVATOR SLAT AND POST ASSEMBLY
33	ELEVATOR AND KNIFE CYLINDERS
35	KNIFE FRAME AND SELECTOR SUPPORT
37	FILM SELECTOR AIR CYLINDERS
39	SIDE CLAMP AND SIDE UNDERFOLDER MOTORS
41	SIDE CLAMPS
43	SIDE UNDERFOLDERS
45	SIDE CLAMP, SIDE UNDERFOLDER BELTS, AND PULLEYS
47	GRIPPER AND GRIPPER DRIVE BELT
49	GRIPPER SPRING ASSEMBLY
51	GRIPPER DRIVE, SEALER BELT SENSORS, AND HEIGHT SENSORS
53	LEFT FRONT FOLDER AND SEALER BELT PACKAGE SENSOR
55	RIGHT FRONT FOLDER, SHUTTLE, AND REAR UNDERFOLDER MOTOR
57	UPPER PUSHER AND FRONT FOLDER MOTORS
59	PACKAGE HOLD DOWN (ML-44230 & ML-44231)
61	PUSHER AND HOLD DOWN (COSTCO) (ML-44233 & ML-44234)
63	PUSHER AND REAR UNDERFOLDER
65	FILM SELECTOR
67	FILM SUPPLY ARBOR
69	FILM HEATER
71	HEAT EXCHANGER
73	BELT SEALER
75	BELT SEALER MOTOR
77	LABEL APPLIER
79	LABEL APPLIER ARM WITH MOTOR
81	LABEL APPLIER (WAND AND BLOCK)
83	COMPRESSOR ASSEMBLY (GAST)
85	AIR DRYER FILTER ASSEMBLY
87	AIR MANIFOLD ASSEMBLY
89	HOSE DIAGRAM (MAIN)

- 91 HOSE DIAGRAM (PRINTER PLATE)
- 93 AWS SHELF
- 95 CYCLE COUNTER
- 97 DISCHARGE ROLLER ASSEMBLY

NOTES

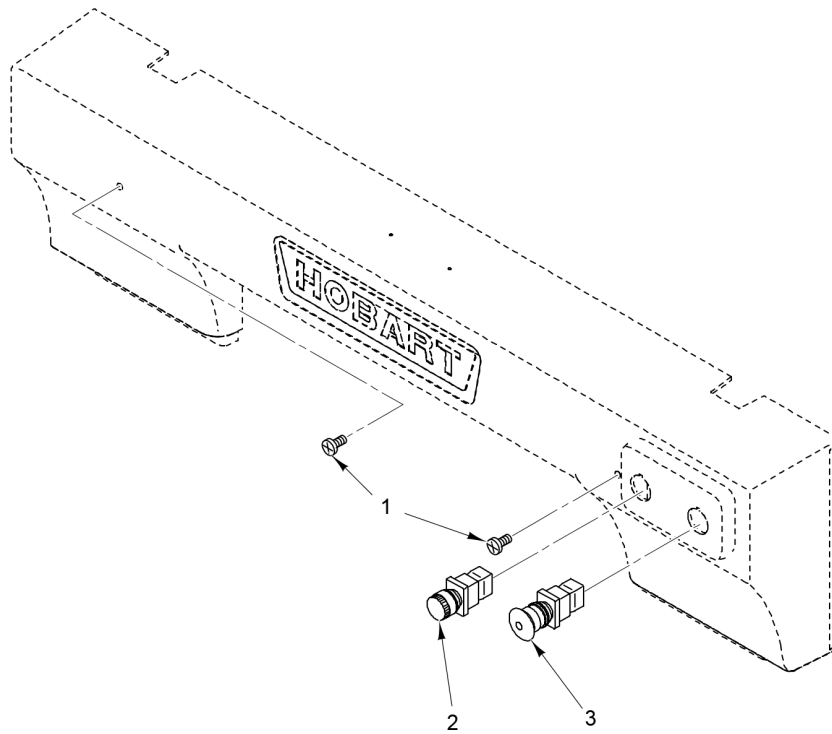

PL-59964

RUN AND STOP SWITCH

RUN AND STOP SWITCH

ILLUS. PL-59964	PART NO.	NAME OF PART	AMT.
1	SC-080-13	Mach. Screw 10-24 x 7/8 Phil. Fil. Hd. (SST).....	2
2	00-445456	Switch Assy. - Push Button (Illuminated) (Teknic).....	1
3	00-445457	Switch Assy. - Push Button (Mushroom Type) (Teknic).....	1

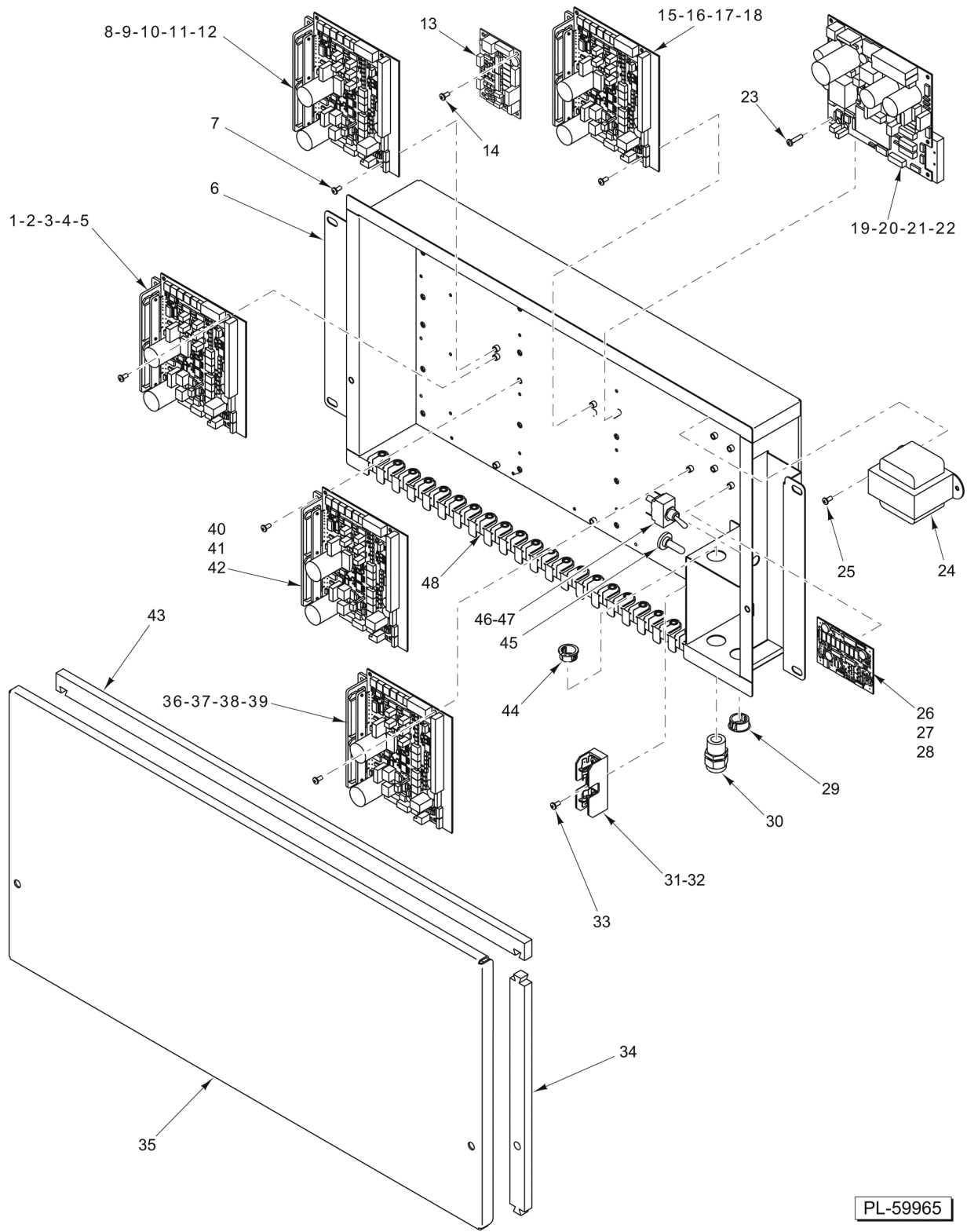

PL-59965

CONTROL BOX

CONTROL BOX

ILLUS.	PART NO.	NAME OF PART	AMT.
1	00-445330-00001	Board Assy. - Combo (Node 3).....	1
2	00-441406-00003	Fuse (250 V., 2 Amp.).....	1
3	00-441406-00005	Fuse (250 V., 3.15 Amp.).....	1
4	00-445078	Fuse (250 V., 1.5 Amp.).....	1
5	00-445816	Fuse (250 V., 0.5 Amp.).....	3
6	00-446304	Control Box Assy.....	1
7	SC-018-31	Mach. Screw 8-32 x 3/8 Phil. Pan Hd.....	AR
8	00-445330-00002	Board Assy. - Combo (Node 1).....	1
9	00-441406-00007	Fuse (250 V., 4 Amp.).....	1
10	00-441406-00003	Fuse (250 V., 2 Amp.).....	1
11	00-445078	Fuse (250 V., 1.5 Amp.).....	1
12	00-445816	Fuse (250 V., 0.5 Amp.).....	1
13	00-446137	Board Assy. - USB Node.....	1
14	SC-018-31	Mach. Screw 8-32 x 3/8 Phil. Pan Hd.....	AR
15	00-445330-00002	Board Assy. - Combo (Node 2).....	1
16	00-441406-00005	Fuse (250 V., 3.15 Amp.).....	2
17	00-445078	Fuse (250 V., 1.5 Amp.).....	1
18	00-445816	Fuse (250 V., 0.5 Amp.).....	3
19	00-447352	Kit - Power Supply & Cables.....	1
20	00-441406-00006	Fuse (250 V., 5 Amp.).....	1
21	00-443398	Fuse (250 V., 20 Amp.).....	1
22	00-441406-00008	Fuse (250 V., 6.3 Amp.).....	4
23	SC-018-37	Mach. Screw 8-32 x 3/4 Phil. Pan Hd.....	2
24	00-446414	Transformer (120/24 VAC) (75 Amp.).....	1
25	SC-018-37	Mach. Screw 8-32 x 3/4 Phil. Pan Hd.....	2
26	00-445440	Board - Stepper Motor.....	1
27	00-441406-00001	Fuse (250 V., 1 Amp.).....	1
28	00-441406-00002	Fuse (250 V., 2.5 Amp.).....	1
29	PB-004-08	Plug Button Heyco 2703.....	1
30	FE-022-84	Connector - Strain Relief.....	1
31	00-444736	Block - Fuse.....	1
32	FE-026-56	Fuse (600 V., 15 Amp.).....	1
33	SC-018-37	Mach. Screw 8-32 x 3/4 Phil. Pan Hd.....	2
34	00-446315-00002	Gasket - Control Box.....	2
35	00-446327	Cover - Control Box.....	1
36	00-445330-00001	Board Assy. - Combo (Node 5).....	1
37	00-441406-00003	Fuse (250 V., 2 Amp.).....	1
38	00-445078	Fuse (250 V., 1.5 Amp.).....	1
39	00-445816	Fuse (250 V., 0.5 Amp.).....	1
40	00-445330-00001	Board Assy. - Combo (Node 4).....	1
41	00-441406-00003	Fuse (250 V., 2 Amp.).....	2
42	00-445078	Fuse (250 V., 1.5 Amp.).....	1
43	00-446315-00001	Gasket - Control Box.....	2
44	FE-016-24	Bushing - Electrical Split.....	1
45	00-446412	Boot - Splashproof.....	1
46	00-446410	Switch - Toggle.....	1
47	00-446900	Shield - Switch.....	1
48	00-443881	Grommet.....	21

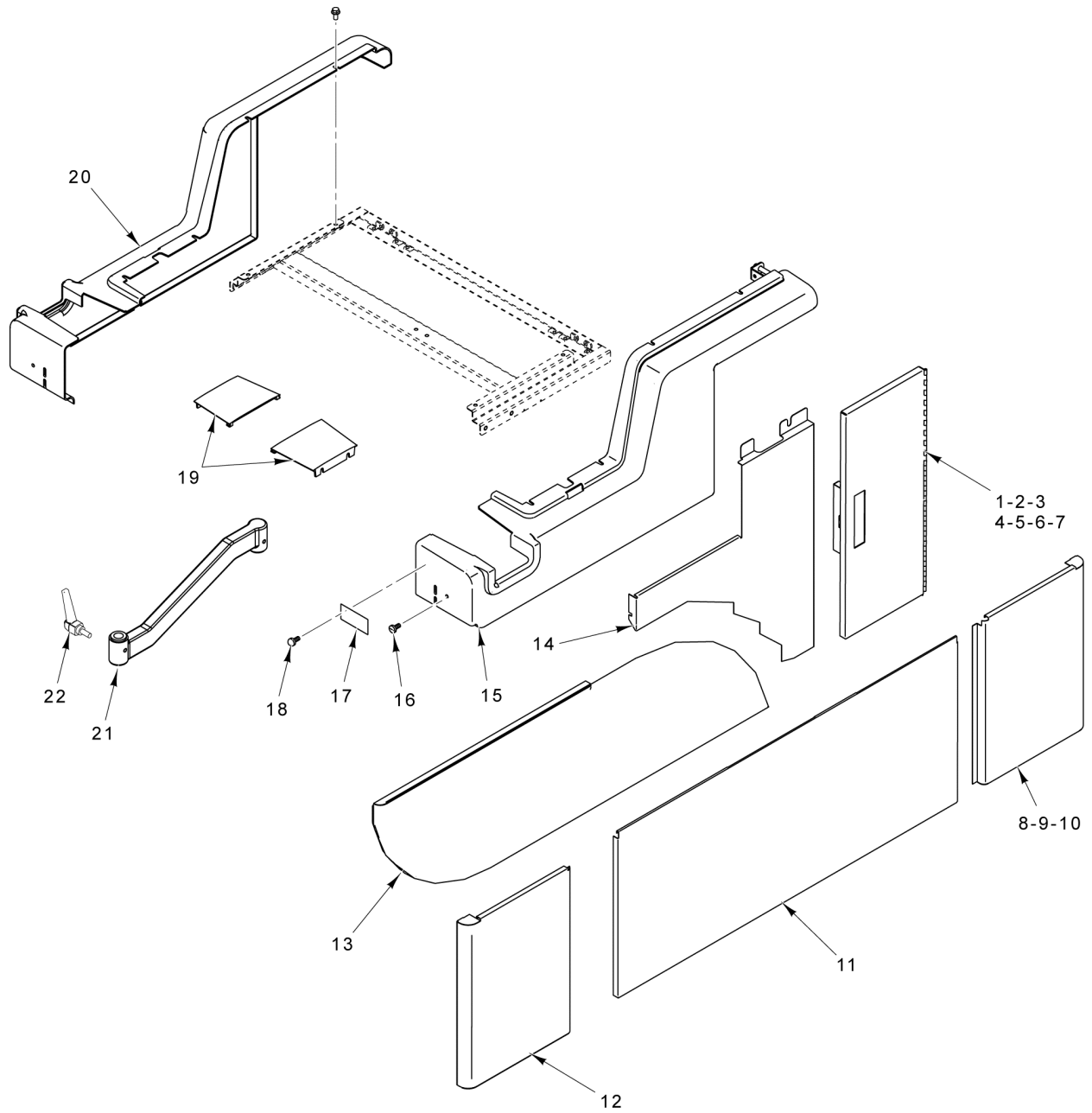

PL-59966

UPPER AND SIDE PANELS

UPPER AND SIDE PANELS

ILLUS.	PART NO.	NAME OF PART	AMT.
1	00-444343	Cover - Side Door Assy.....	1
2	00-442435	Pull - Flush Door.....	1
3	00-446772	Actuator - Magnet.....	1
4	00-175998	Sensor.....	1
5	00-183396	Plate - Nut.....	2
6	SC-113-10	Mach. Screw 4-40 x 3/8 Phil. Pan Hd.....	2
7	00-443209	Interlock Harness Assy. (Incls. Item 4).....	1
8	00-444337	Cover - Corner.....	1
9	SC-129-49	Mach. Screw 1/4-20 x 1/2 Hex Washer Hd. (SST).....	2
10	NS-049-06	Lock Nut 1/4-20 (SST).....	2
11	00-444350	Cover - Lower Right.....	1
12	00-444338	Cover - Corner.....	1
13	00-444331	Cover - Lower Front (RH).....	1
14	00-444342	Cover - Front Right.....	1
15	00-444057	Cover - Side (RH).....	1
16	SC-053-41	Mach. Screw 1/4-20 x 1/2 Slotted Truss Hd. (SST).....	10
17	00-438131-00009	Label - Warning.....	2
18	SD-033-56	Self-Tapping Screw #2 x 3/16 Rd. Hd., Type U (SST).....	4
19	00-444058	Cover - Printer Mount.....	2
20	00-444056	Cover - Side (LH).....	1
21	00-444328	Arm - Support (Display Assy.).....	1
22	00-442734	Knob - Console Mount.....	2

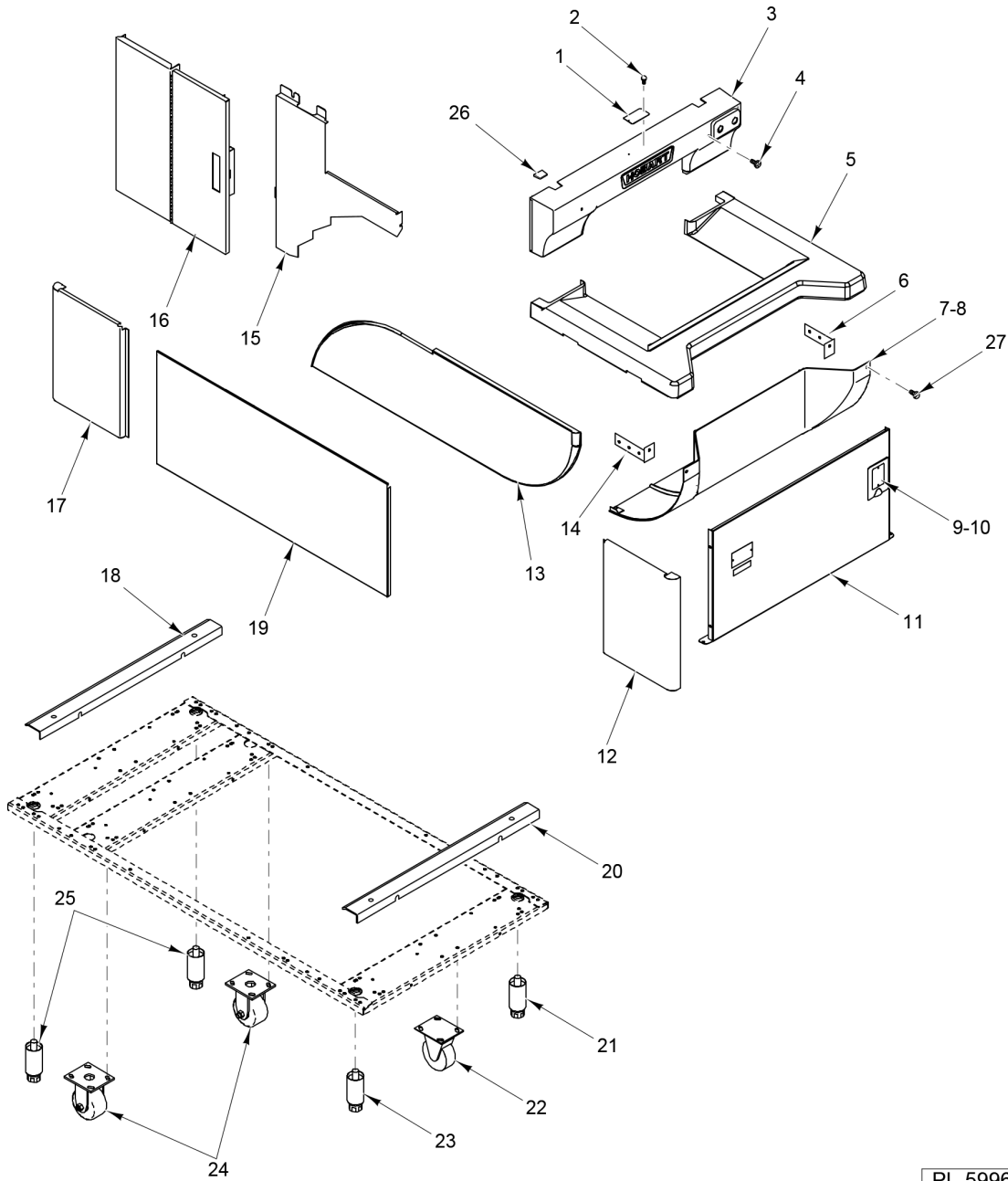

PL-59967

LOWER AND SIDE PANELS

LOWER AND SIDE PANELS

ILLUS. PL-59967	PART NO.	NAME OF PART	AMT.
1	00-438131-00007	Plate - Warning.....	1
2	SD-033-56	Self-Tapping Screw #2 x 3/16 Rd. Hd., Type U (SST).....	2
3	00-444333	Cover - Intake Panel.....	1
4	SC-080-13	Mach. Screw 10-24 x 7/8 Phil. Fil. Hd. (SST).....	2
5	00-444334	Cover - Intake.....	1
6	00-446858	Bracket - Intake Mount (RH).....	1
7	00-446874	Kit - Intake Cover (Incls. Item 8).....	1
8	00-446873	Bushing - Cover.....	2
9	00-444892-00001	Cover Assy. - Switch.....	1
10	00-444524	Spring - Door.....	2
11	00-444339	Cover - Front End.....	1
12	00-444337	Cover - Corner.....	2
13	00-444330	Cover - Lower Front (LH).....	1
14	00-446857	Bracket - Intake Mount (LH).....	1
15	00-444341	Cover - Front Left.....	1
16	00-444343	Cover - Side Door Assy.....	1
17	00-444338	Cover - Corner.....	2
18	00-444286	Bracket - Cover Mounting.....	1
19	00-444348	Cover - Lower Left.....	1
20	00-444286	Bracket - Cover Mounting.....	1
21	00-330866	Leg - Adjustable (4 In.).....	1
22	00-447427	Caster - Swivel (With Brake).....	1
23	00-330866	Leg - Adjustable (4 In.).....	1
24	00-444676	Caster Fixed.....	2
25	00-330866	Leg - Adjustable (4 In.).....	2
26	00-444352	Cover - Sensor.....	1
27	SC-053-41	Mach. Screw 1/4-20 x 1/2 Slotted Truss Hd. (SST).....	2

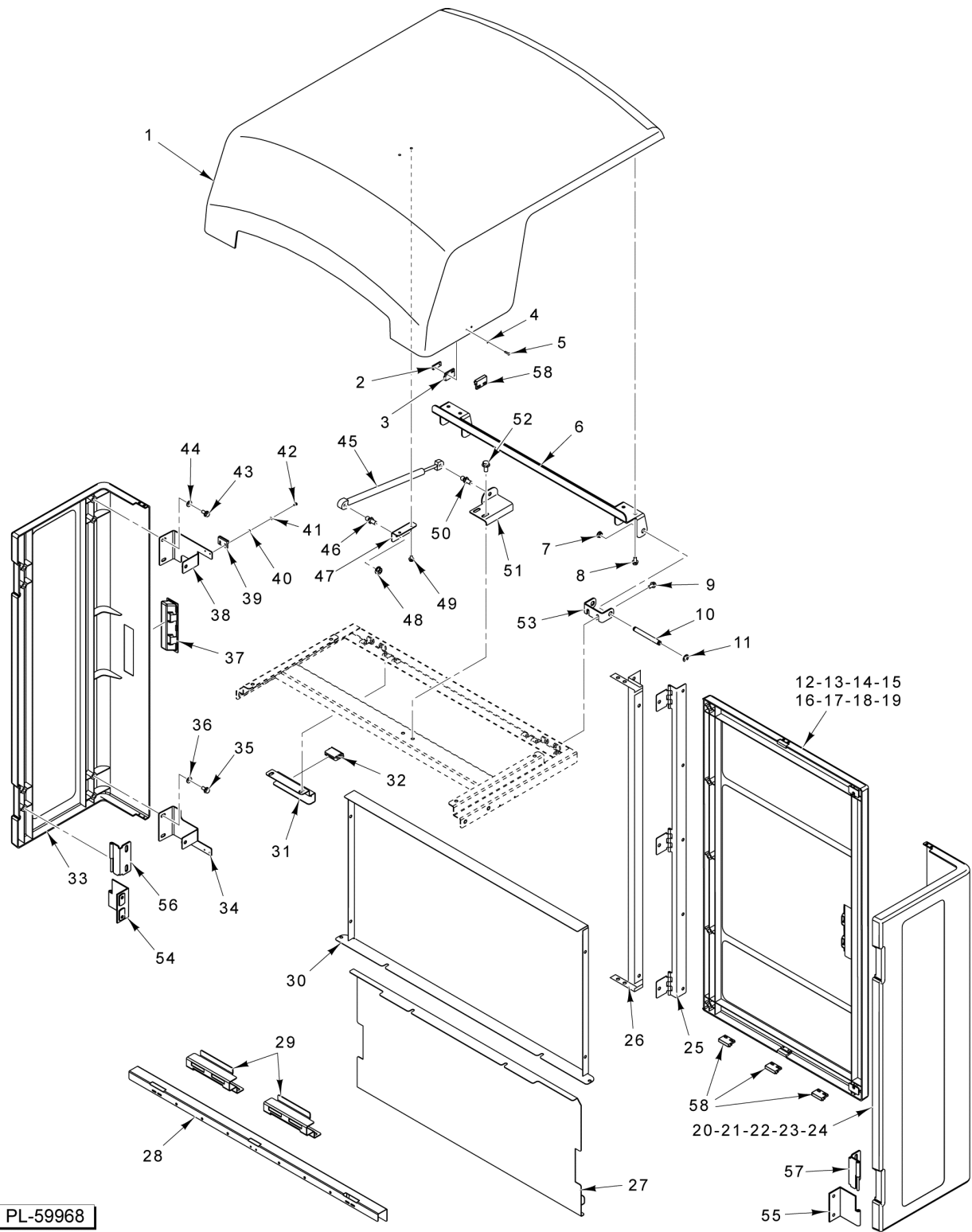

CANOPY AND REAR PANELS

CANOPY AND REAR PANELS

ILLUS.	PART NO.	NAME OF PART	AMT.
PL-59968			
1	00-913102-00165	Kit - Canopy & Gas Spring (Incls. Items 2 thru 6 & 45 thru 51).....	1
2	00-183396	Plate - Screw Switch.....	1
3	00-446772	Actuator - Magnet.....	1
4	WS-029-24	Washer.....	2
5	SC-021-02	Mach. Screw 4-40 x 1/2 Slotted Rd. Hd. (SST).....	2
6	00-446573	Hinge - Canopy.....	1
7	00-041488	Bearing (Nyliner).....	4
8	SC-129-49	Mach. Screw 1/4-20 x 1/2 Hex Washer Hd. (SST).....	4
9	SC-129-49	Mach. Screw 1/4-20 x 1/2 Hex Washer Hd. (SST).....	2
10	00-444102	Pin - Canopy Hinge.....	2
11	RR-009-10	Retaining Ring 3/8 In. (SST).....	2
12	00-446668	Door - Rear (Incls. Items 13 thru 19).....	1
13	00-446772	Actuator - Magnet.....	1
14	00-183396	Plate - Screw Switch.....	1
15	00-542795	Tape - Double Sided (Very High Bonding).....	AR
16	00-446594	Brace - Door.....	2
17	SC-021-02	Mach. Screw 4-40 x 1/2 Slotted Rd. Hd. (SST).....	2
18	WL-003-03	Lockwasher #4 Helical.....	2
19	WS-029-24	Washer.....	2
20	00-446702	Kit - Corner Door (Incls. Items 21 thru 24, 28, 29, 34 thru 38, 43, & 44).....	1
21	00-446772	Actuator - Magnet.....	1
22	SC-018-68	Mach. Screw 4-40 x 1/4 Phil. Pan Hd.....	2
23	WL-003-03	Lockwasher #4 Helical.....	2
24	WS-029-24	Washer.....	2
25	00-445188	Hinge - Rear Film Door.....	1
26	00-445186	Bracket - Hinge Mounting.....	1
27	00-443994	Panel - Rear.....	1
28	00-446664	NLA - Obsolete--Bracket - Switch Mounting.....	1
29	00-446572	Bracket - Door Magnet.....	2
30	00-444340	Cover - Back End.....	1
31	00-446572	Bracket - Door Magnet.....	1
32	00-041725	Catch - Magnetic.....	1
33	00-446702	Kit - Corner Door (Incls. Items 28, 29, & 34 thru 44).....	1
34	00-446578	NLA - Obsolete--Bracket - Door Stop (RH Door - Upper; LH Door - Lower).....	1
35	SC-129-49	Mach. Screw 1/4-20 x 1/2 Hex Washer Hd. (SST).....	2
36	WS-003-49	Washer 0.266 x 0.563 x 0.062 (SST).....	2
37	00-442435	Pull - Flush Door.....	1
38	00-446579	NLA - Obsolete--Bracket - Door Stop (RH Door - Lower; LH Door - Upper).....	1
39	00-446772	Actuator - Magnet.....	1
40	WS-029-24	Washer.....	2
41	WL-003-03	Lockwasher #4 Helical.....	2
42	SC-018-68	Mach. Screw 4-40 x 1/4 Phil. Pan Hd.....	2
43	SC-129-49	Mach. Screw 1/4-20 x 1/2 Hex Washer Hd. (SST).....	2
44	WS-003-49	Washer 0.266 x 0.563 x 0.062 (SST).....	2
45	00-446712	Spring - Gas Canopy (Incls. Items 47 & 51).....	1
46	00-444110	Stud - Ball.....	1
47	00-446709	Bracket - Cylinder.....	1
48	NS-048-40	Lock Nut 5/16-18 Flange (SST).....	2
49	SC-100-04	Mach. Screw 10-24 x 3/8 Hex Washer Hd.....	2
50	00-444110	Stud - Ball.....	1
51	00-446665	Bracket - Strut Mounting.....	1
52	SC-129-49	Mach. Screw 1/4-20 x 1/2 Hex Washer Hd. (SST).....	2
53	00-444105	Hinge - Canopy.....	1
54	00-444060	Hinge - Female (LH).....	2
55	00-444061	Hinge - Female (RH).....	2
56	00-444062	Hinge - Male (LH).....	2
57	00-444063	Hinge - Male (RH).....	2
58	00-443209	Interlock Harness Assy.....	4

- 31 00-444424 Seal - Wire Roto
 32 00-441937-00003 USB Cable (15 Ft.)
PARTS NOT ILLUSTRATED

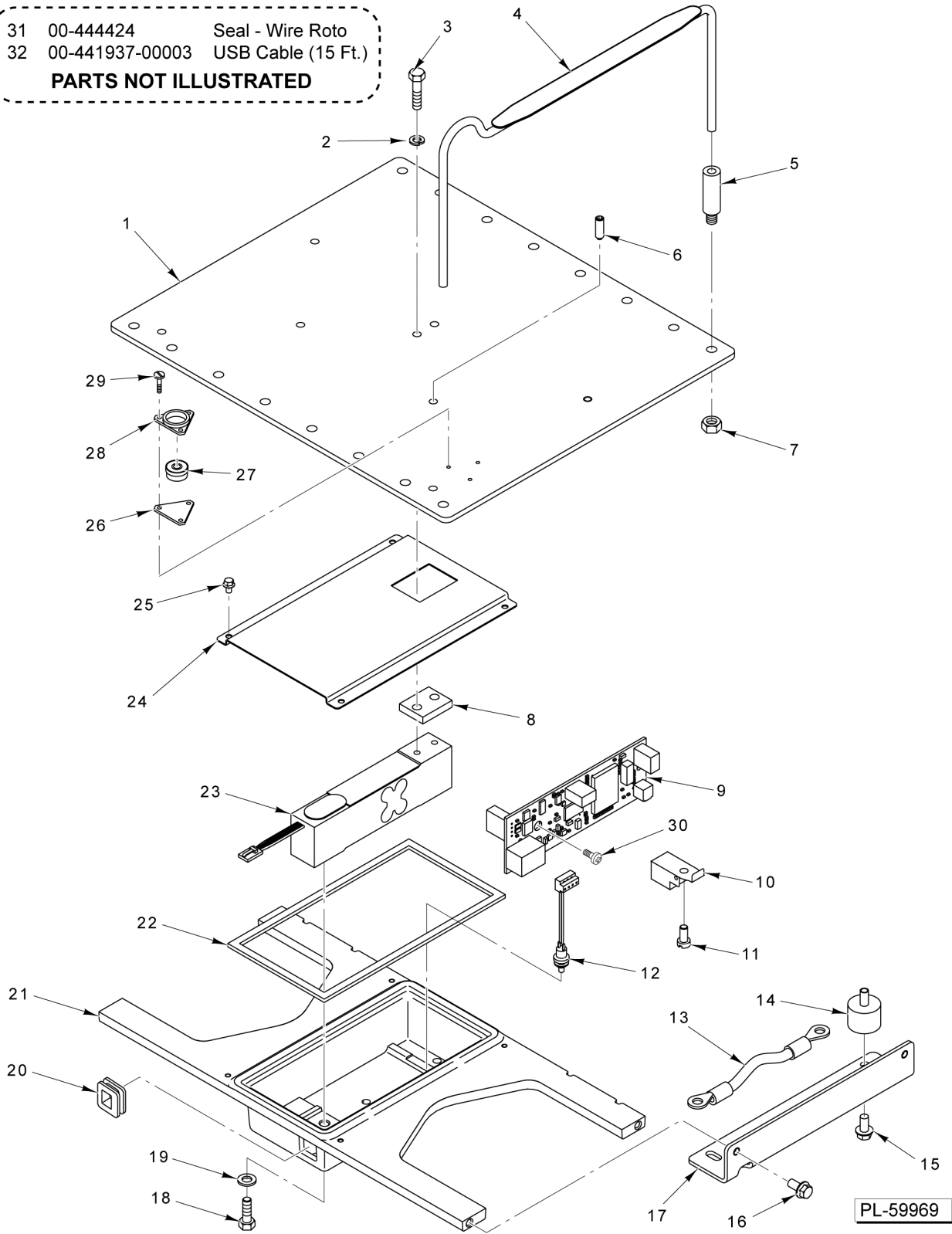

SCALE PLATFORM

SCALE PLATFORM

ILLUS. PL-59969	PART NO.	NAME OF PART	AMT.
1	00-444688	Support - Platter.....	1
2	WL-006-17	Lockwasher 1/4 Helical (SST).....	2
3	SC-041-03	Cap Screw 1/4-20 x 1-1/8 Hex Hd. (SST).....	2
4	00-444476	Rod - Weigher Assy.....	8
5	00-444689	Retainer - Platter.....	2
6	SC-129-53	Set Screw 1/4-20 x 3/4 Hex Hdls., Dog Pt. (SST).....	6
7	NS-018-10	Jam Nut 5/16-24 Hex (SST).....	16
8	00-444701	Spacer - Loadcell.....	1
9	00-446167	Board Assy. - USB Weigher.....	1
10	00-445153	Cover - Switch.....	1
11	00-046869	Screw - Sealing 10-24 x 3/8 Slotted Fil. Hd.....	1
12	00-444568	Switch Assy. - Push Button.....	1
13	00-183458	Cable Assy. - Ground.....	1
14	00-444038	Mount - Hinge.....	4
15	SC-129-49	Mach. Screw 1/4-20 x 1/2 Hex Washer Hd. (SST).....	4
16	SC-129-49	Mach. Screw 1/4-20 x 1/2 Hex Washer Hd. (SST).....	4
17	00-444971	Bracket - Scale Mounting.....	2
18	SC-109-47	Cap Screw 1/4-20 x 7/8 Hex Hd. (SST).....	2
19	WL-006-17	Lockwasher 1/4 Helical (SST).....	4
20	00-444129	Seal - USB.....	1
21	00-444128	Support - Machined Loadcell.....	1
22	00-444641	Gasket - Loadcell Cover.....	1
23	00-446240	Load Cell (20 kg) (Multiple Range).....	1
24	00-443820	Cover - Loadcell.....	1
25	SC-128-55	Mach. Screw 8-32 x 1/4 Hex Hd.....	4
26	00-049040	Gasket - Level Flange.....	1
27	00-043112	Level - Spirit.....	1
28	00-047276	Flange.....	1
29	SC-124-80	Mach. Screw 4-40 x 5/16 Slotted Flat Hd. (SST).....	3
30	SC-123-74	Mach. Screw 8-32 x 5/8 Phil. Pan Hd. (SST).....	1
31	00-444424	Seal - Wire Roto (8 In.) (Not Shown).....	AR
32	00-441937-00003	Cable - USB (2.0 A-B) (15 Ft.) (Not Shown).....	1

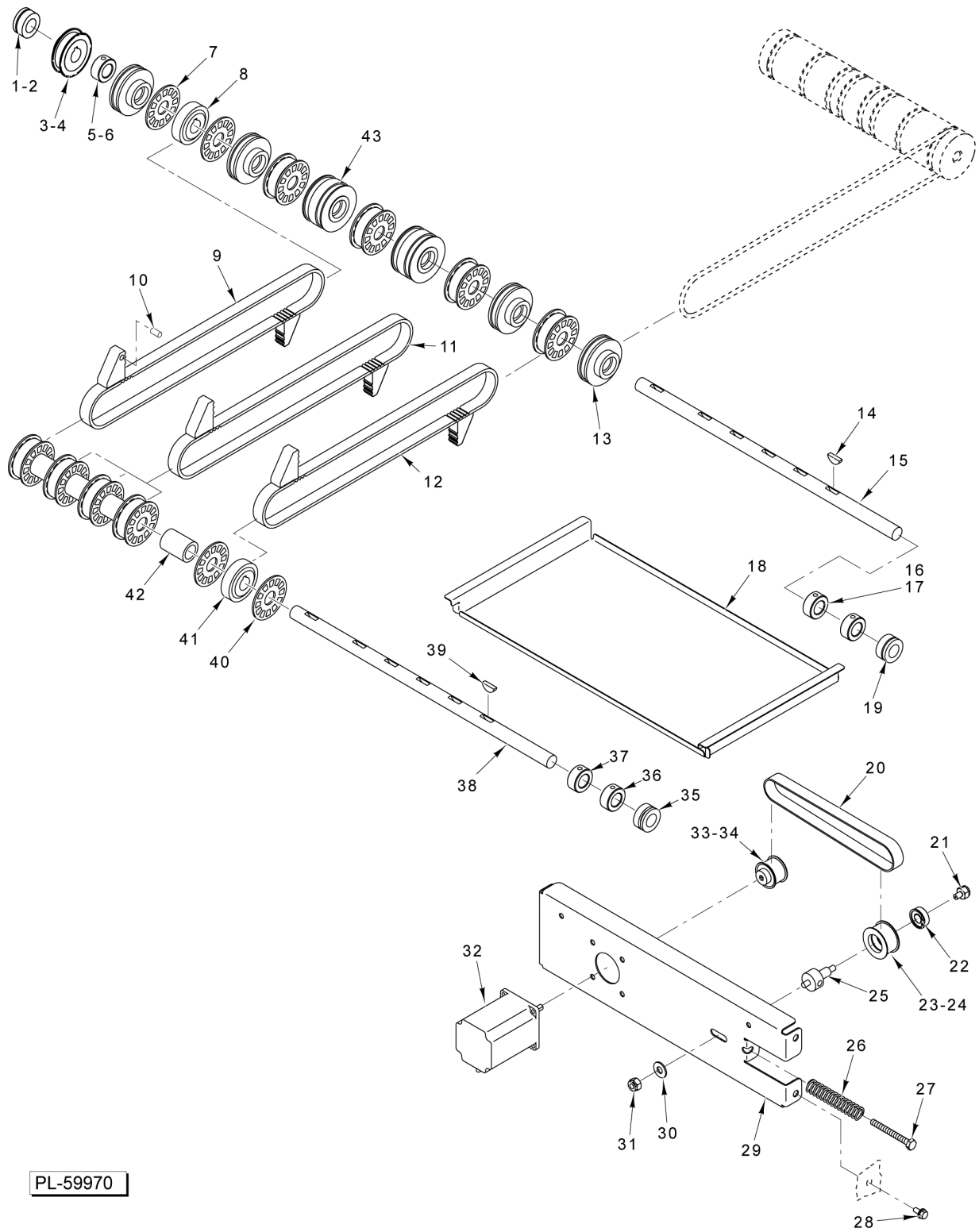

PL-59970

PRIMARY INTAKE AND SHIFTER

PRIMARY INTAKE AND SHIFTER

ILLUS.	PART NO.	NAME OF PART	AMT.
PL-59970			
1	00-443827	Bearing 5/8 (1/16 Groove).....	1
2	SC-119-81	Set Screw 5/16-18 x 5/16 Hex Hdls. Cup Pt. (SST).....	1
3	00-443868	Pulley (30T) (Incls. Item 4).....	1
4	SC-125-19	Set Screw 10-32 x 1/4 Hex Hdls., Cup Pt. (SST).....	1
5	00-443821	Collar 5/8 (SST) (Incls. Item 6).....	1
6	SC-119-81	Set Screw 5/16-18 x 5/16 Hex Hdls. Cup Pt. (SST).....	1
7	00-446785	Flange.....	10
8	00-446784	Pulley (5mm) (30T).....	5
9	00-443936	Belt - Intake (White) (Incls. Item 10).....	1
10	00-443938	Magnet.....	1
11	00-445271	Belt - Intake (Gray).....	3
12	00-443937	Belt - Intake (White).....	1
13	00-443888	Pulley - Idler.....	4
14	KW-003-10	Key - Woodruff 3/16 x 3/4.....	1
15	00-443889	Shaft - Drive.....	1
16	00-443821	Collar 5/8 (SST) (Incls. Item 17).....	1
17	SC-119-81	Set Screw 5/16-18 x 5/16 Hex Hdls. Cup Pt. (SST).....	1
18	00-445503	Pan - Intake.....	1
19	00-443827	Bearing 5/8 (1/16 Groove).....	1
20	00-446216	Belt (450mm) (90T).....	1
21	NS-036-19	Stop Nut 5/16-18 Hex (SST).....	4
22	00-443943	Bearing - Ball.....	1
23	RR-012-32	Retaining Ring.....	1
24	00-443866	Pulley - Idler (Incls Items 22 & 23).....	1
25	00-443900	Spacer - Idler.....	1
26	00-445948	Spring - Shift Belt.....	1
27	SC-129-52	Cap Screw 1/4-20 x 4-1/2 Hex Hd. (SST).....	1
28	SC-129-49	Mach. Screw 1/4-20 x 1/2 Hex Washer Hd. (SST).....	1
29	00-445947	Bracket Assy.....	1
30	WS-029-05	Washer (SST).....	1
31	NS-036-19	Stop Nut 5/16-18 Hex (SST).....	1
32	00-442248	Motor - Stepper (Shifter).....	1
33	00-443861	Pulley (18T) (Incls. Item 34).....	1
34	SC-125-19	Set Screw 10-32 x 1/4 Hex Hdls., Cup Pt. (SST).....	1
35	00-443828	Bearing 5/8 (1/8 Groove).....	2
36	00-443821	Collar 5/8 (SST).....	2
37	00-446082	Collar.....	2
38	00-443889	Shaft - Drive.....	1
39	KW-004-05	Key - Woodruff 3/16 x 3/4 (SST).....	5
40	00-446785	Flange.....	10
41	00-446784	Pulley (5mm) (30T).....	5
42	00-446734	Spacer.....	4
43	00-443897	Pulley - Idler.....	2
	00-446732	Shaft Assy. (Idler) (Incls. Items 35 thru 42).....	1

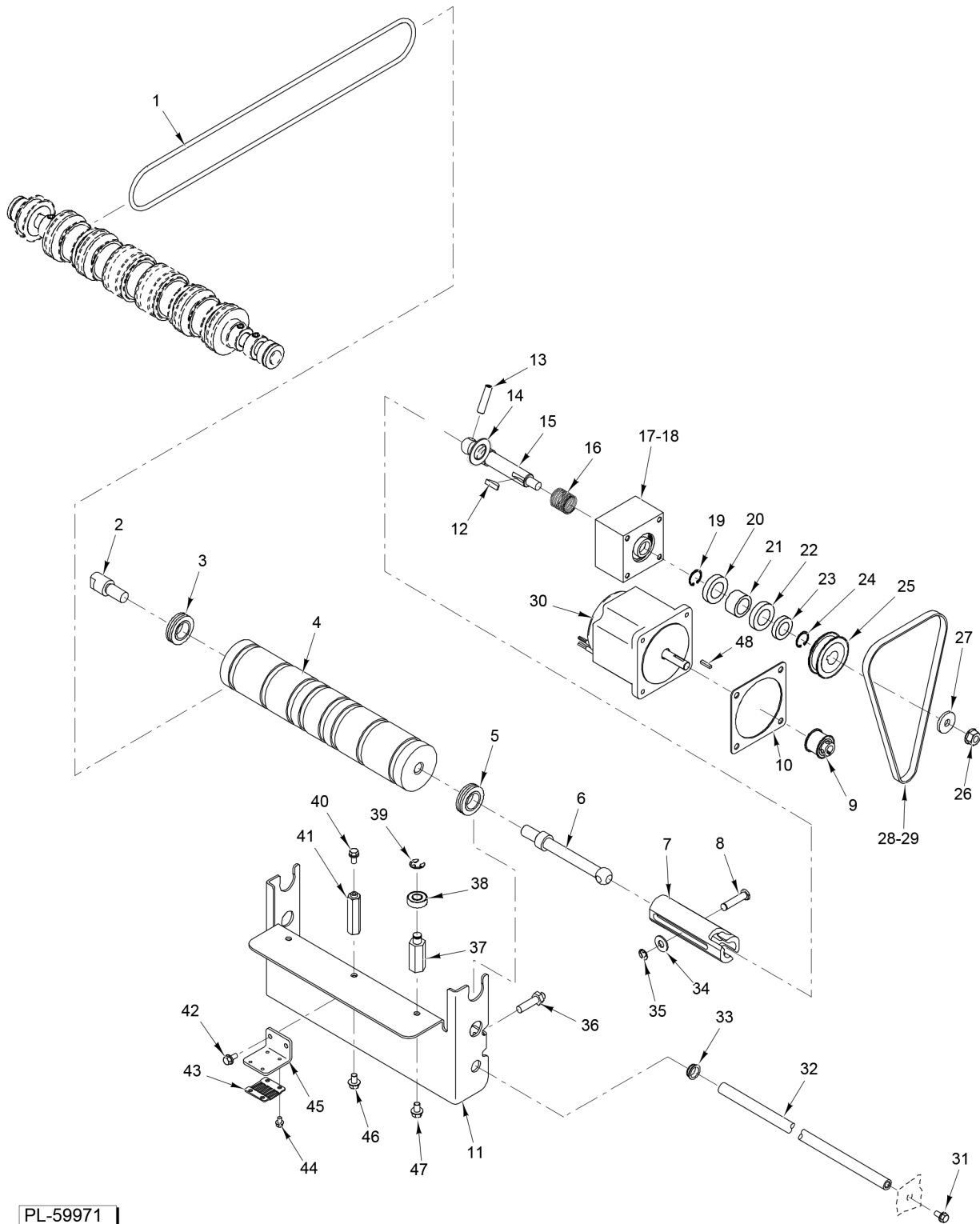

PL-59971

PRIMARY INTAKE SHIFT CONVEYOR AREA

PRIMARY INTAKE SHIFT CONVEYOR AREA

ILLUS. PL-59971	PART NO.	NAME OF PART	AMT.
1	00-446065	Belt - Intake Shift Conveyor (Clear).....	8
2	00-443883	Shaft (LH).....	1
3	00-443826	Bearing 3/4.....	1
4	00-446064	Roller - Conveyor (Knurled) (Incls. Items 2 & 6).....	1
5	00-443826	Bearing 3/4.....	1
6	00-443859	Shaft - Drive.....	1
7	00-443942	Coupling - Intake Drive.....	1
8	00-443884	Pin - Clevis 5/16 (SST).....	1
9	00-443860	Pulley (16T).....	1
10	00-443963	Spacer - Motor Mounting.....	1
11	00-443857	Bracket - Slide.....	1
12	KW-004-05	Key - Woodruff 3/16 x 3/4 (SST).....	1
13	RP-006-42	Pin - Roll 0.312 x 1-1/4 (SST).....	1
14	00-444537	Washer.....	1
15	00-443964	Shaft - Drive.....	1
16	00-444353	Spring - Shift Collar.....	1
17	00-443949	Block - Bearing Mount.....	1
18	00-444539	Drive Assy. - Conveyor (Incls. Items 12 thru 17 & 19 thru 26).....	1
19	RR-012-01	Retaining Ring.....	1
20	00-443950	Bearing.....	1
21	00-443961	Spacer - Bearing.....	1
22	00-443950	Bearing.....	1
23	00-443962	Spacer - Pulley.....	1
24	RR-012-01	Retaining Ring.....	1
25	00-445504	Pulley (30T) (Use with 15mm Belt).....	2
26	NS-038-10	Lock Nut 3/8-16 Hex.....	1
27	WS-028-37	Washer (SST).....	1
28	00-443934	Belt - Conveyor Drive (9mm).....	1
29	00-446220	Belt - Conveyor Drive (15mm) (107T).....	1
30	00-446002	Motor - Brushless (220 W.) (82 In. Motor Lead) (Secondary Intake Drive).....	1
31	SC-129-49	Mach. Screw 1/4-20 x 1/2 Hex Washer Hd. (SST).....	1
32	00-443858	Shaft.....	1
33	00-043411	Bearing (Nyliner).....	1
34	WS-029-05	Washer (SST).....	1
35	RR-012-27	Retaining Ring.....	1
36	00-443238	Magnet - Sensor.....	1
37	00-443887	Stud - Eccentric.....	2
38	00-443943	Bearing - Ball.....	2
39	RR-009-10	Retaining Ring 3/8 In. (SST).....	2
40	SC-066-22	Mach. Screw 10-32 x 3/8 Phil. Truss Hd. (SST).....	1
41	00-443892	Pivot - Drive Post.....	1
42	SC-129-49	Mach. Screw 1/4-20 x 1/2 Hex Washer Hd. (SST).....	1
43	00-443906	Clamp - Belt.....	1
44	SC-128-55	Mach. Screw 8-32 x 1/4 Hex Hd.....	4
45	00-443899	Bracket - Belt Mounting.....	1
46	SC-100-08	Mach. Screw 1/4-20 x 3/8 Hex Washer Hd.....	1
47	SC-129-49	Mach. Screw 1/4-20 x 1/2 Hex Washer Hd. (SST).....	1
48	KW-003-23	Key - Woodruff 3/32 x 5/8.....	1

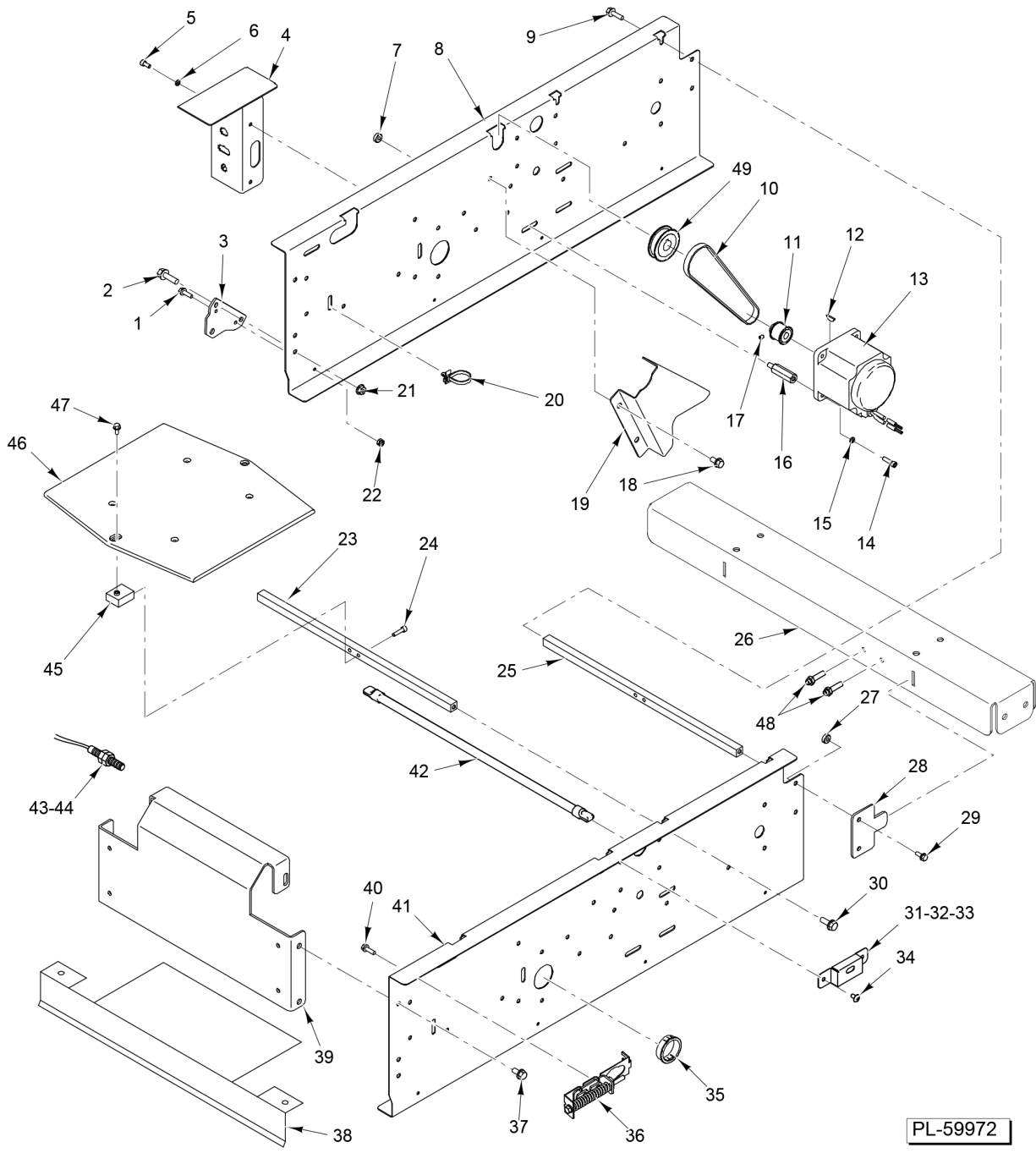

INTAKE FRAME

INTAKE FRAME

ILLUS.	PART NO.	NAME OF PART	AMT.
1	SC-093-04	Mach. Screw 8-32 x 1/2 Phil. Pan Hd. (SST).....	2
2	SC-129-49	Mach. Screw 1/4-20 x 1/2 Hex Washer Hd. (SST).....	2
3	00-444459	Bracket Assy. - Intake Mounting.....	2
4	00-445835	Bracket - Connector Mounting.....	1
5	SC-066-22	Mach. Screw 10-32 x 3/8 Phil. Truss Hd. (SST).....	2
6	WL-006-07	Lockwasher #10 Helical (SST).....	2
7	NS-049-06	Lock Nut 1/4-20 (SST).....	2
8	00-443822	Frame - Conveyor (LH).....	1
9	SC-129-49	Mach. Screw 1/4-20 x 1/2 Hex Washer Hd. (SST).....	2
10	00-446214	Belt - Weigher (450mm) (95T).....	1
11	00-443860	Pulley (16T) (Incls. Item 17).....	1
12	KW-004-09	Key - Woodruff.....	1
13	00-443220	Motor - Brushless (220 W.) (Primary Intake Drive).....	1
14	SC-059-17	Cap Screw 10-32 x 3/4 Hex Socket Hd. (SST).....	4
15	WL-006-07	Lockwasher #10 Helical (SST).....	4
16	00-443851	Spacer - Motor.....	3
17	SC-125-19	Set Screw 10-32 x 1/4 Hex Hdls., Cup Pt. (SST).....	2
18	SC-129-49	Mach. Screw 1/4-20 x 1/2 Hex Washer Hd. (SST).....	2
19	00-443894	Guard Assy. - Belt.....	1
20	00-444428	Tie - Cable Releasable.....	1
21	NS-049-06	Lock Nut 1/4-20 (SST).....	1
22	NS-031-08	Stop Nut 8-32 Special (SST).....	1
23	00-443886	Spacer.....	1
24	SC-059-17	Cap Screw 10-32 x 3/4 Hex Socket Hd. (SST).....	4
25	00-443886	Spacer.....	1
26	00-446036	Support - Intake Assy.....	1
27	NS-049-06	Lock Nut 1/4-20 (SST).....	4
28	00-443825	Bracket - Alignment.....	2
29	SC-129-49	Mach. Screw 1/4-20 x 1/2 Hex Washer Hd. (SST).....	4
30	SC-129-49	Mach. Screw 1/4-20 x 1/2 Hex Washer Hd. (SST).....	2
31	00-443177	Housing Assy. - Tab.....	1
32	00-446516	Bracket - Light Tube.....	2
33	00-442143	Board Assy. - Sensor Control.....	1
34	SC-066-22	Mach. Screw 10-32 x 3/8 Phil. Truss Hd. (SST).....	2
35	FE-023-53	Bushing - Snap.....	2
36	00-445364	Tension Assy. (Incls. Item 40).....	2
37	SC-129-49	Mach. Screw 1/4-20 x 1/2 Hex Washer Hd. (SST).....	2
38	00-445053	Shield - Deflector.....	1
39	00-443893	Guard - Mercer.....	1
40	SC-129-49	Mach. Screw 1/4-20 x 1/2 Hex Washer Hd. (SST).....	4
41	00-443823	Frame - Conveyor (RH).....	1
42	00-446088	Tube - Light Assy.....	1
43	00-446022	Sensor - Position (Primary Home).....	1
44	NS-018-10	Jam Nut 5/16-24 Hex (SST).....	2
45	00-443890	Block - Pivot.....	1
46	00-443891	Bed - Pivoting Conveyor.....	1
47	SC-066-22	Mach. Screw 10-32 x 3/8 Phil. Truss Hd. (SST).....	2
48	00-446021	Sensor - Position (Home Limit).....	2
49	00-443868	Pulley (5mm) (30T).....	1
	00-446254	Kit - Light Tube Replacement (Incls. Items 31, 32, 33, & 42).....	1

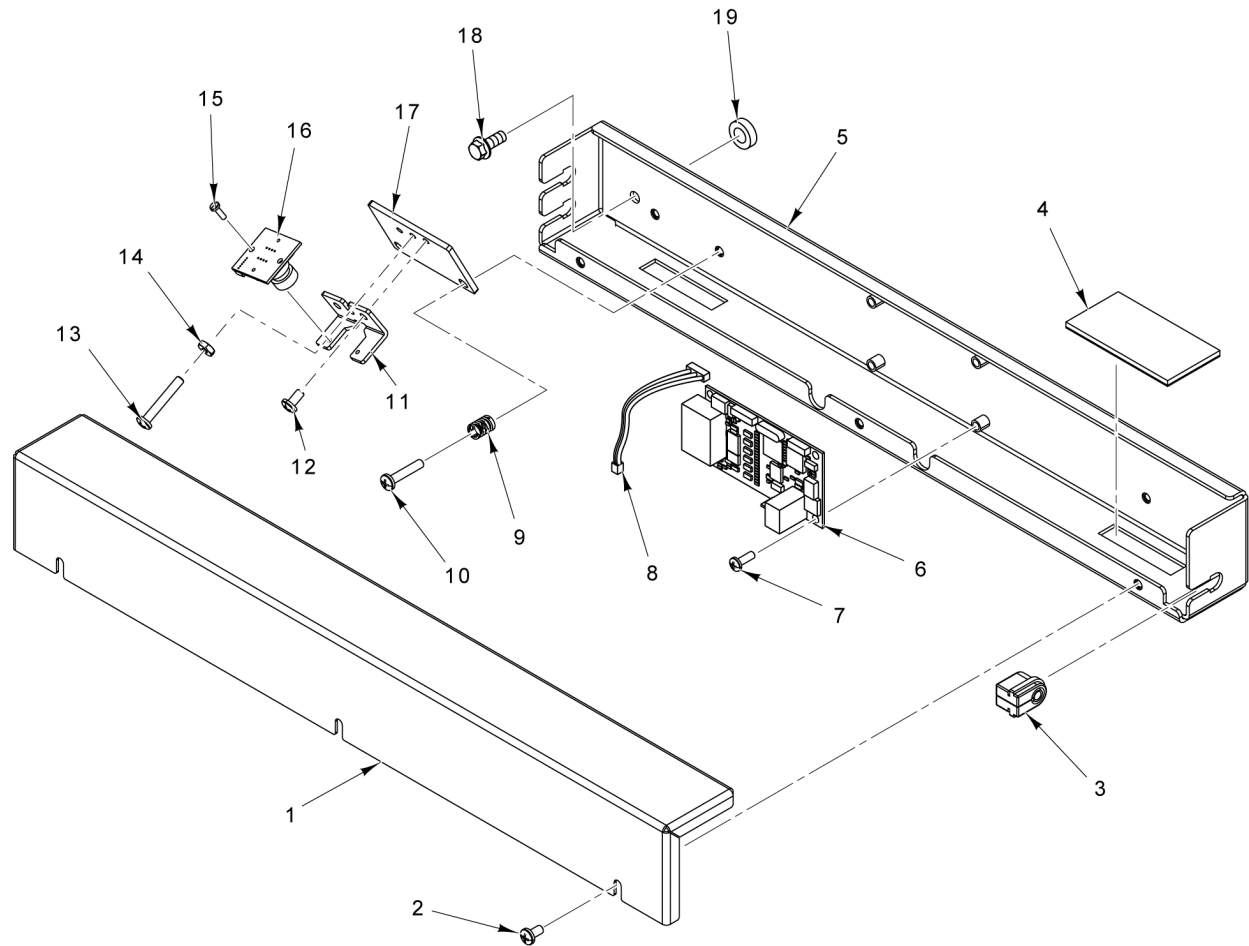

20 00-443378 Cable
PART NOT ILLUSTRATED

PL-60532

CAMERA ENCLOSURE

CAMERA ENCLOSURE

ILLUS.	PART NO.	NAME OF PART	AMT.
PL-60532			
1	00-446181	Cover - Camera.....	1
2	SC-018-25	Mach. Screw 10-32 x 3/8 Phil. Pan Hd.....	3
3	00-443881	Grommet.....	3
4	00-446233	Lens Assy. (Incls. Gasket).....	2
5	00-446180	Enclosure - Camera.....	1
6	00-447415	Board Assy. - Sensor Control.....	1
7	SC-018-34	Mach. Screw 8-32 x 1/2 Phil. Pan Hd.....	4
8	00-443199-00001	Cable (Camera-to-Camera Board).....	2
9	00-444443	Spring - Compression.....	4
10	SC-125-69	Mach. Screw 10-32 x 1 Phil. Pan Hd.....	4
11	00-446178	Bracket - Camera.....	2
12	SC-018-25	Mach. Screw 10-32 x 3/8 Phil. Pan Hd.....	4
13	SC-125-71	Mach. Screw 10-32 x 1-1/4 Phil. Pan Hd. (SST).....	2
14	NS-011-23	Nut 10-32 Hex (SST).....	2
15	SC-113-10	Mach. Screw 4-40 x 3/8 Phil. Pan Hd.....	4
16	00-442140	Board Assy. - Sensor Array Camera.....	2
17	00-446179	Bracket - Angle Adjustment.....	2
18	SC-129-50	Mach. Screw 1/4-20 x 5/8 Hex Washer Hd. (SST).....	2
19	00-444445	Spacer.....	2
20	00-443378	Cable (Camera Control) (Camera Board to Node 1).....	1

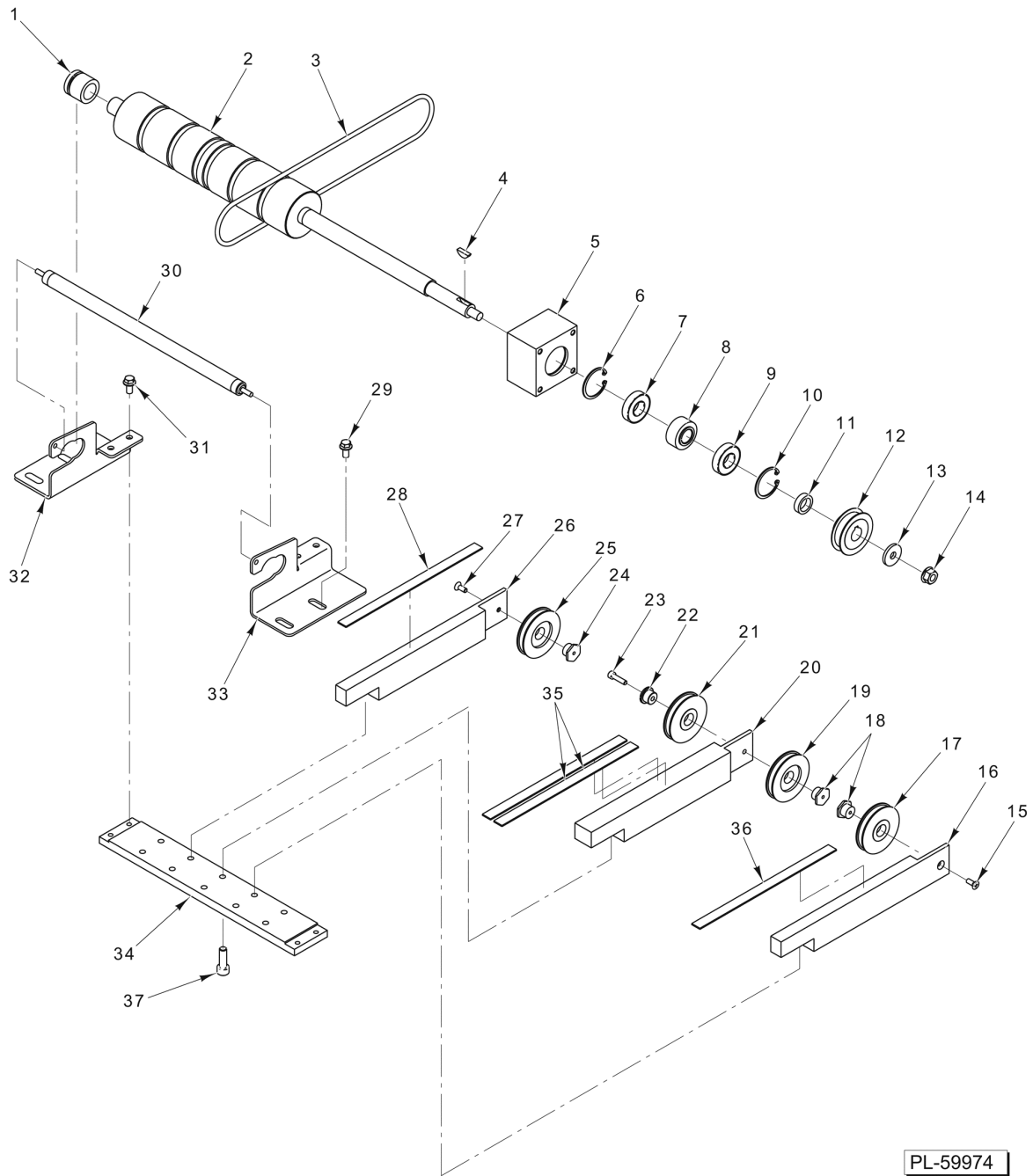

PL-59974

ELEVATOR CONVEYOR ASSEMBLY

ELEVATOR CONVEYOR ASSEMBLY

ILLUS. PL-59974	PART NO.	NAME OF PART	AMT.
1	00-443960	Bearing (5/8).....	1
2	00-444463	Roller Assy.....	1
3	00-443948	Belt - Elevator Conveyor.....	6
4	KW-004-05	Key - Woodruff 3/16 x 3/4 (SST).....	1
5	00-443949	Block - Bearing Mount.....	1
6	RR-012-01	Retaining Ring.....	1
7	00-443950	Bearing.....	2
8	00-443961	Spacer - Bearing.....	1
9	00-443950	Bearing.....	2
10	RR-012-01	Retaining Ring.....	1
11	00-443962	Spacer - Pulley.....	1
12	00-445504	Pulley (30T).....	1
13	WS-028-37	Washer (SST).....	1
14	NS-038-10	Lock Nut 3/8-16 Hex.....	1
15	SC-114-99	Mach. Screw 10-32 x 1/2 Phil. Flat Hd. (SST).....	2
16	00-443952	Rail (RH).....	2
17	00-443954	Pulley - Idler.....	2
18	00-443953	Stud - Pulley Mounting.....	3
19	00-443954	Pulley - Idler.....	1
20	00-443958	Rail - Center.....	1
21	00-443954	Pulley - Idler.....	1
22	00-443959	Stud - Pulley.....	1
23	SC-059-17	Cap Screw 10-32 x 3/4 Hex Socket Hd. (SST).....	1
24	00-443953	Stud - Pulley Mounting.....	2
25	00-443954	Pulley - Idler.....	2
26	00-443951	Rail (LH).....	2
27	SC-114-99	Mach. Screw 10-32 x 1/2 Phil. Flat Hd. (SST).....	2
28	00-443957	Wearstrip.....	2
29	SC-129-49	Mach. Screw 1/4-20 x 1/2 Hex Washer Hd. (SST).....	2
30	00-443955	Roller.....	1
31	SC-129-49	Mach. Screw 1/4-20 x 1/2 Hex Washer Hd. (SST).....	4
32	00-447254	Bracket - Conveyor (LH).....	1
33	00-447253	Bracket - Conveyor (RH).....	1
34	00-447255	Bar - Conveyor.....	1
35	00-443957	Wearstrip.....	2
36	00-443957	Wearstrip.....	2
37	SC-129-73	Mach. Screw 1/4-20 x 1 Hex Washer Hd.(SST).....	10

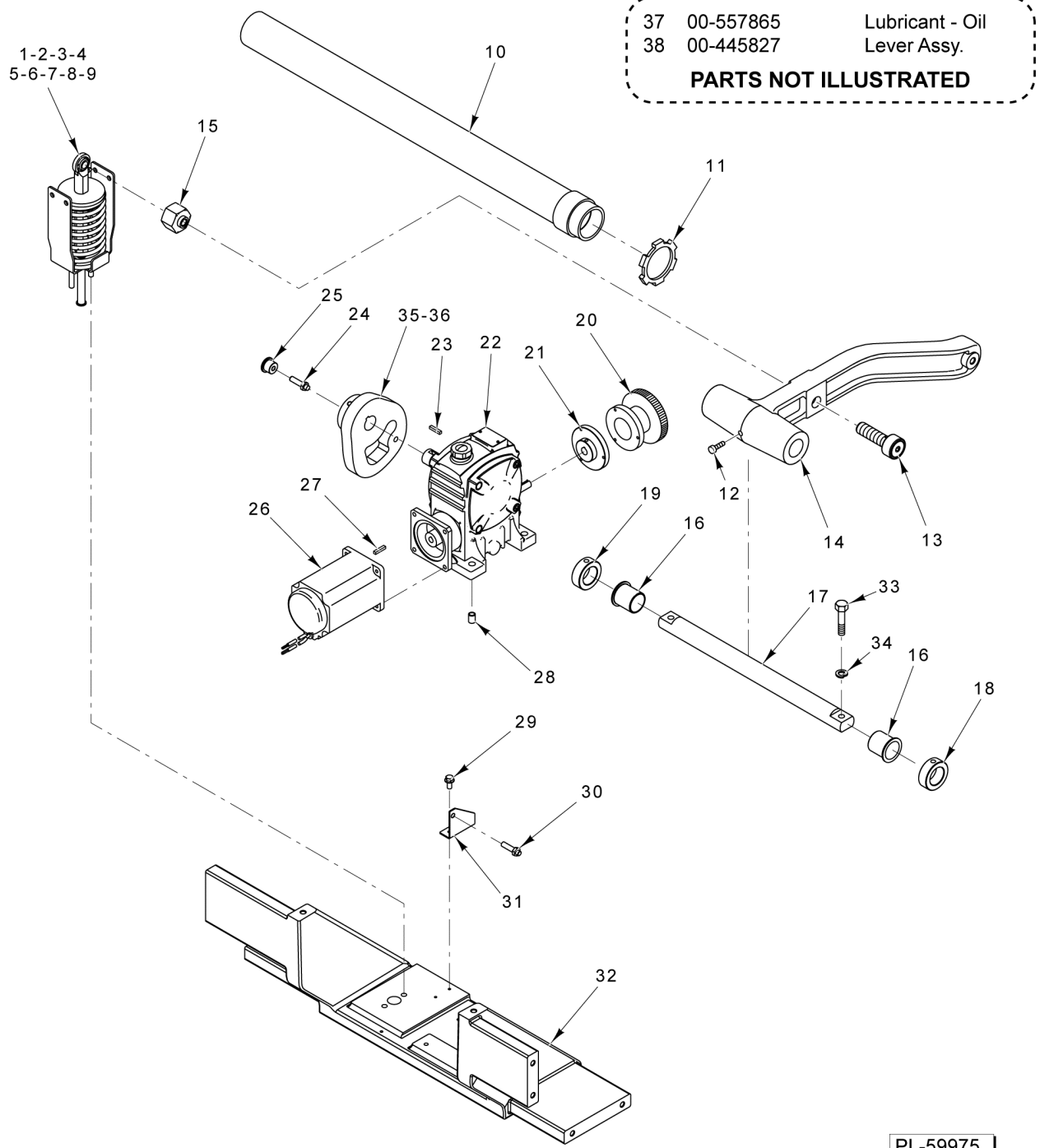

ELEVATOR MOTOR

ELEVATOR MOTOR

ILLUS.	PART NO.	NAME OF PART	AMT.
	PL-59975		
1	00-043411	Bearing (Nyliner).....	1
2	00-444380	End - Rod 1/2-20 (RH).....	1
3	00-444390	Plate - Spring Mounting.....	1
4	00-444391	Bracket Assy. - Spring.....	1
5	00-444392	Spring - Elevator.....	1
6	00-444393	Link - Spring.....	1
7	SC-123-92	Mach. Screw 1/4-20 x 5/8 Hex Washer Hd.....	1
8	WS-022-04	Washer (SST).....	1
9	00-444389	Spring Assy. (Incls. Items 1 thru 8).....	1
10	00-444408	Conduit - Electrical.....	1
11	FE-012-19	Lock Nut - Electrical.....	1
12	00-445241	Fitting - Grease.....	1
13	00-445950	Bearing - Cam Follower 5/8-18.....	1
14	00-445949	Lever - Elevator.....	1
15	00-445951	Nut - Cam Follower.....	1
16	00-444386	Bearing - Flanged 1-1/4.....	2
17	00-444387	Shaft - Elevator Lever.....	1
18	00-444456	Collar Assy. 1-1/4 (SST).....	1
19	00-444456	Collar Assy. 1-1/4 (SST).....	1
20	00-442492	Wheel - Hand.....	1
21	00-444388	Hub - Handwheel.....	1
22	00-444117	Gear - Reducer.....	1
23	KW-004-10	Key - Woodruff.....	1
24	00-443238	Magnet - Sensor.....	1
25	00-444495	Sleeve.....	2
26	00-446035	Motor - Brushless (660 W.) (54 In. Motor Lead).....	1
27	KW-003-23	Key - Woodruff 3/32 x 5/8.....	1
28	00-444786	Spacer - Gearbox.....	4
29	SC-129-49	Mach. Screw 1/4-20 x 1/2 Hex Washer Hd. (SST).....	2
30	00-446021	Sensor - Position.....	1
31	00-445615	Bracket - Home Switch.....	1
32	00-444234	Mount - Gearmotor.....	1
33	SC-041-32	Cap Screw 3/8-16 x 1-1/2 Hex Hd. (SST).....	2
34	WL-006-28	Lockwasher 3/8 Helical.....	2
35	00-444987	Cam - Elevator.....	1
36	SC-075-15	Set Screw 5/16-18 x 3/8 Hex Hdls., Cup Pt.....	2
37	00-557865	Lubricant - Oil.....	AR
38	00-445827	Lever Assy. - Elevator (Incls. Items 12 thru 16).....	1

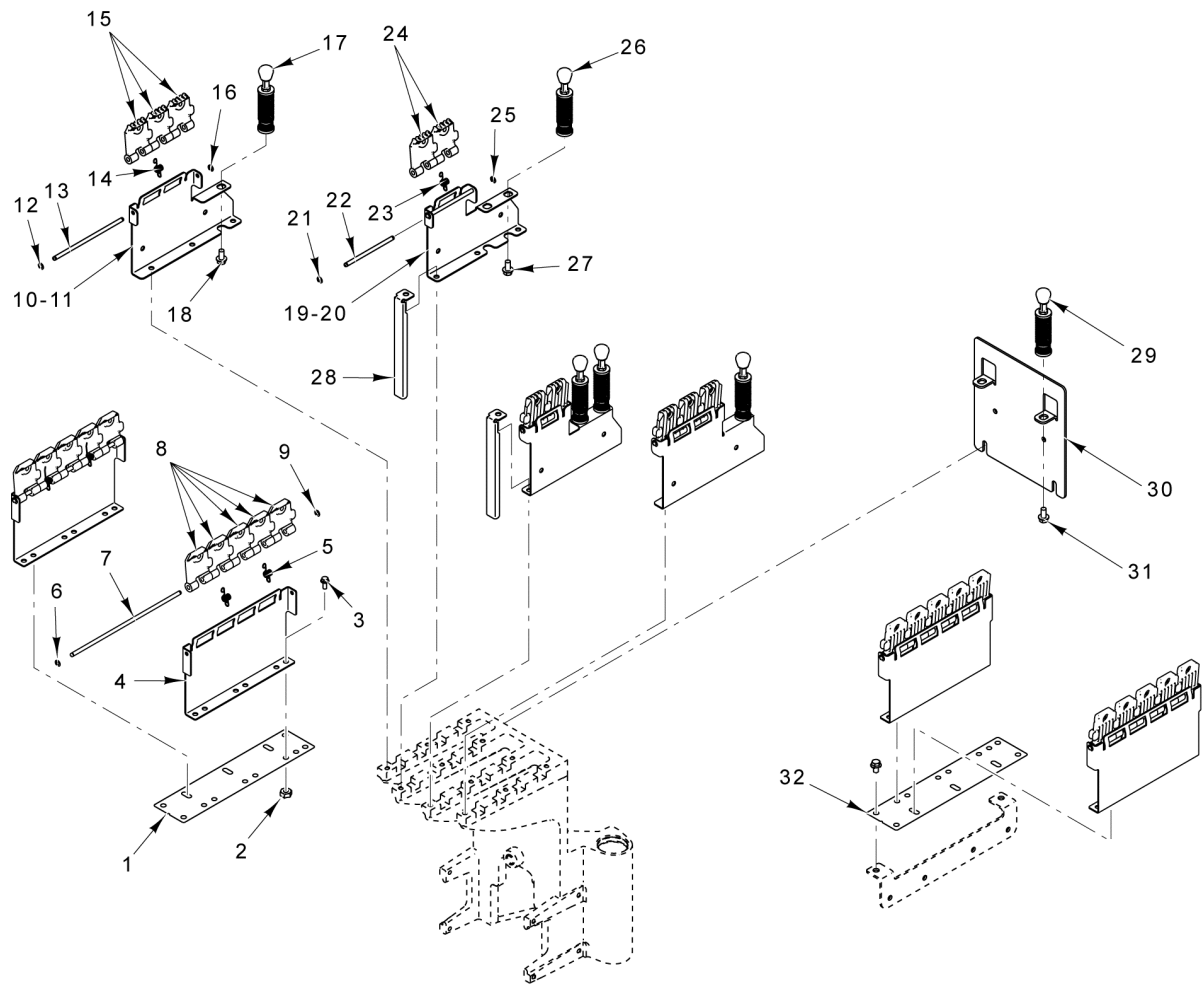

PL-60533

ELEVATOR SLAT AND POST ASSEMBLY

ELEVATOR SLAT AND POST ASSEMBLY

ILLUS. PL-60533	PART NO.	NAME OF PART	AMT.
1	00-446449	Plate - Post Mounting.....	1
2	NS-049-06	Lock Nut 1/4-20 (SST).....	6
3	SC-129-49	Mach. Screw 1/4-20 x 1/2 Hex Washer Hd. (SST).....	6
4	00-446046	Bracket - Slat.....	4
5	00-446699	Spring - Slat.....	4
6	RR-006-03	Retaining Ring.....	2
7	00-446050	Rod - Slat.....	2
8	00-334067	Slat.....	10
9	RR-006-03	Retaining Ring.....	2
10	00-445006	Bracket - Slat Assy. (LH) (3 Slat) (Incls. Items 12 thru 18).....	1
11	00-445013	Bracket - Slat Assy. (RH) (3 Slat) (Incls. Items 12 thru 18).....	1
12	RR-006-03	Retaining Ring.....	2
13	00-444883	Rod (3 Slat).....	2
14	00-446699	Spring - Slat.....	4
15	00-334067	Slat.....	6
16	RR-006-03	Retaining Ring.....	2
17	00-445009	Post Assy. - Elevator.....	2
18	SC-129-49	Mach. Screw 1/4-20 x 1/2 Hex Washer Hd. (SST).....	2
19	00-445005	Bracket - Slat Assy. (LH) (2 Slat) (Incls. Items 21 thru 27).....	2
20	00-445012	Bracket - Slat Assy. (RH) (2 Slat) (Incls. Items 21 thru 27).....	2
21	RR-006-03	Retaining Ring.....	2
22	00-444887	Rod (2 Slat).....	4
23	00-446699	Spring - Slat.....	4
24	00-334067	Slat.....	4
25	RR-006-03	Retaining Ring.....	2
26	00-445009	Post Assy. - Elevator.....	4
27	SC-129-49	Mach. Screw 1/4-20 x 1/2 Hex Washer Hd. (SST).....	4
28	00-445022	Bracket - Package Stop.....	2
29	00-445009	Post Assy. - Elevator.....	2
30	00-445007	Bracket - Post Mounting.....	1
31	SC-129-49	Mach. Screw 1/4-20 x 1/2 Hex Washer Hd. (SST).....	2
32	00-446449	Plate - Post Mounting.....	1

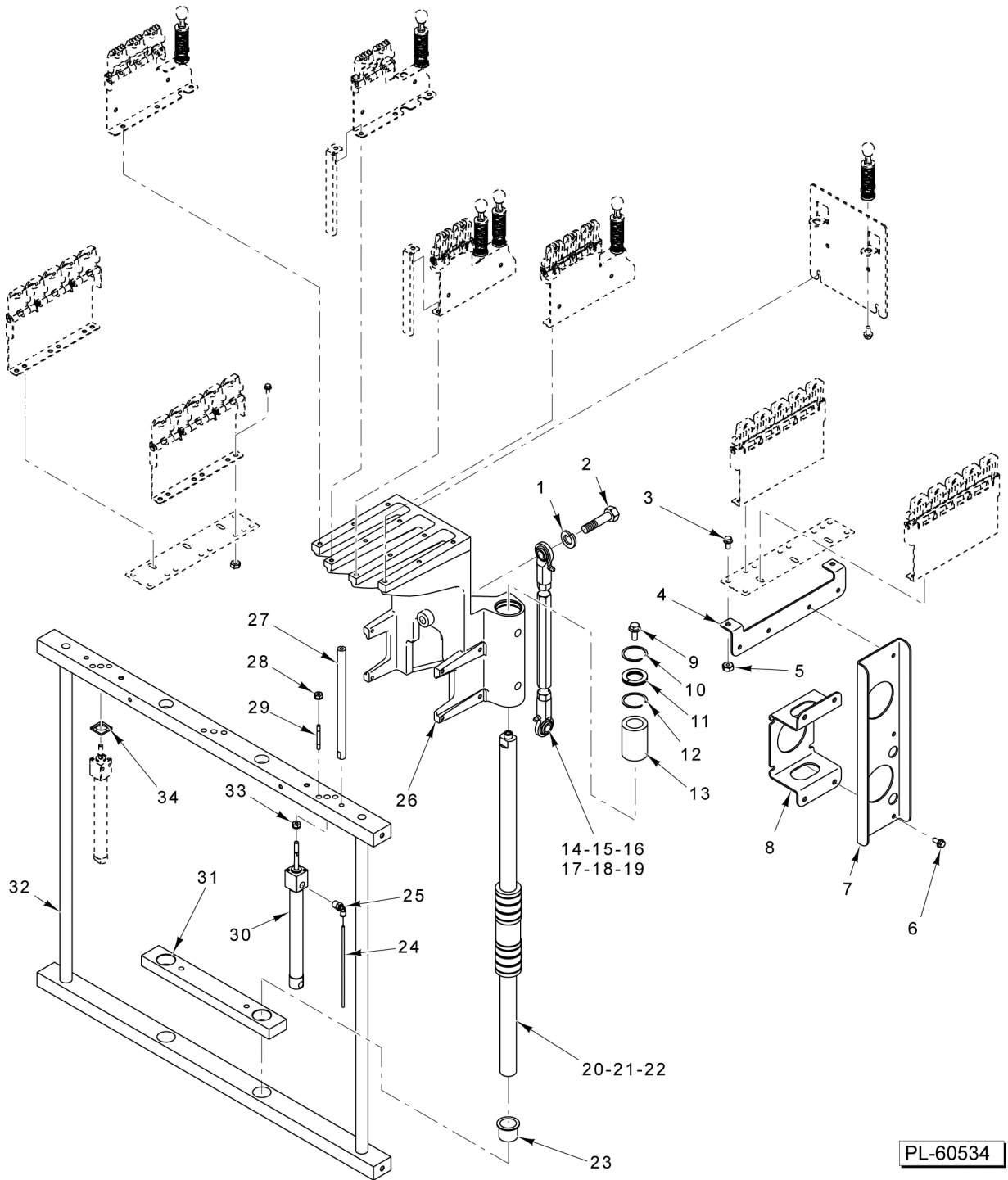

ELEVATOR AND KNIFE CYLINDERS

ELEVATOR AND KNIFE CYLINDERS

ILLUS.	PART NO.	NAME OF PART	AMT.
	PL-60534		
1	WL-006-36	Lockwasher 1/2 Helical.....	1
2	SC-041-45	Cap Screw 1/2-13 x 1-1/2 Hex Hd. (SST).....	1
3	SC-129-49	Mach. Screw 1/4-20 x 1/2 Hex Washer Hd. (SST).....	4
4	00-446272	Bracket - Elevator Side.....	4
5	NS-049-06	Lock Nut 1/4-20 (SST).....	AR
6	SC-129-49	Mach. Screw 1/4-20 x 1/2 Hex Washer Hd. (SST).....	2
7	00-446270	Bracket - Elevator.....	2
8	00-446271	Bracket - Elevator.....	2
9	SC-100-12	Mach. Screw 5/16-18 x 3/4 Hex Washer Hd.....	1
10	00-444563	Ring - Retaining.....	2
11	00-444475	Seal Assy.....	2
12	RR-012-31	Retaining Ring.....	1
13	00-444783	Bearing - Linear.....	1
14	00-444379	Link Assy. - Elevator (Incls. Items 15 thru 19).....	1
15	00-445125	Link - Elevator.....	1
16	00-444380	End - Rod 1/2-20 (RH).....	1
17	00-444381	End - Rod 1/2-20 (LH).....	1
18	NS-015-16	Nut 1/2-20 Hex (SST).....	1
19	NS-048-92	Nut 1/2-20 Hex SST (LH).....	1
20	00-444767	Shaft - Elevator.....	2
21	00-444783	Bearing - Linear.....	4
22	00-444552	Spacer - Bearing.....	2
23	00-442611-00010	Bushing - Sleeve.....	2
24	00-444489-00002	Tubing - Natural Polyurethane (1/8).....	2
25	00-444121	Fitting - Elbow.....	2
26	00-446910	NLA - Obsolete--Support - Elevator Center.....	1
27	00-443905	Rod - Slide.....	2
28	NS-048-19	Mach. Nut 10-32 Hex KEPS (SST).....	4
29	00-445451	Stud - Knife Cylinder.....	4
30	00-447513	Cylinder - Air.....	2
31	00-444768	Bar.....	2
32	00-444229	Elevator Frame.....	1
33	NS-017-60	Jam Nut 1/4-28 Hex.....	2
34	00-445452	Spacer - Knife Cylinder.....	2

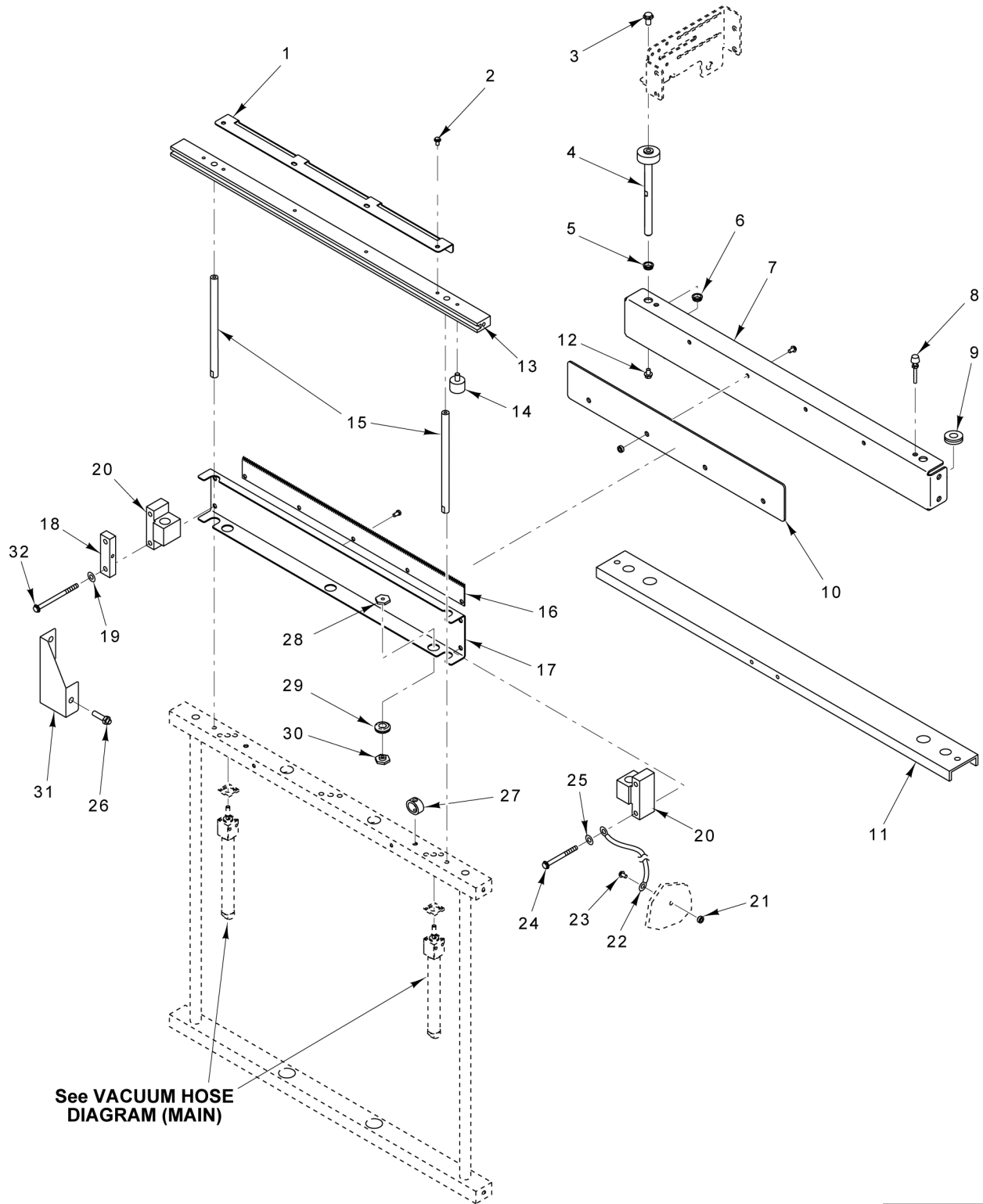

PL-60535

KNIFE FRAME AND SELECTOR SUPPORT

KNIFE FRAME AND SELECTOR SUPPORT

ILLUS. PL-60535	PART NO.	NAME OF PART	AMT.
1	00-443904	Guard - Knife.....	1
2	SC-129-49	Mach. Screw 1/4-20 x 1/2 Hex Washer Hd. (SST).....	4
3	SC-129-51	Cap Screw 5/16-18 x 3/4 Hex Washer Hd. (SST).....	2
4	00-445350	Rod - Selector Assy.....	2
5	00-043411	Bearing (Nyliner).....	1
6	00-043411	Bearing (Nyliner).....	1
7	00-446593	Bracket - Support.....	1
8	00-444240	Screw - Stop Adjustment (Bumper).....	2
9	00-444242	Grommet - Knife.....	2
10	00-444848	Panel - Rear Knife.....	1
11	00-444239	Bracket - Lower Support.....	1
12	SC-100-08	Mach. Screw 1/4-20 x 3/8 Hex Washer Hd.....	2
13	00-443902	Frame - Top Support.....	1
14	00-444827	Bumper - Knife.....	2
15	00-443905	Rod - Slide.....	2
16	00-443903	Knife.....	1
17	00-443907	Bracket - Knife.....	1
18	00-446229	Block Assy. - Magnet.....	1
19	WL-006-17	Lockwasher 1/4 Helical (SST).....	2
20	00-447402	Bearing Assy.....	2
21	NS-049-06	Lock Nut 1/4-20 (SST).....	1
22	00-443396	Ground Strap.....	1
23	SC-123-92	Mach. Screw 1/4-20 x 5/8 Hex Washer Hd.....	1
24	SC-041-07	Cap Screw 1/4-20 x 1-1/2 Hex Hd. (SST).....	2
25	WL-006-17	Lockwasher 1/4 Helical (SST).....	2
26	00-446021	Sensor - Position.....	1
27	00-334272	Bumper.....	1
28	00-443908	Jam Nut (Air Cylinder).....	3
29	00-447747	Washer.....	3
30	00-443908	Jam Nut (Air Cylinder).....	3
31	00-444852	Bracket Assy. (Knife Sensor).....	1
32	SC-041-08	Cap Screw 1/4-20 x 2 Hex Hd. (SST).....	2

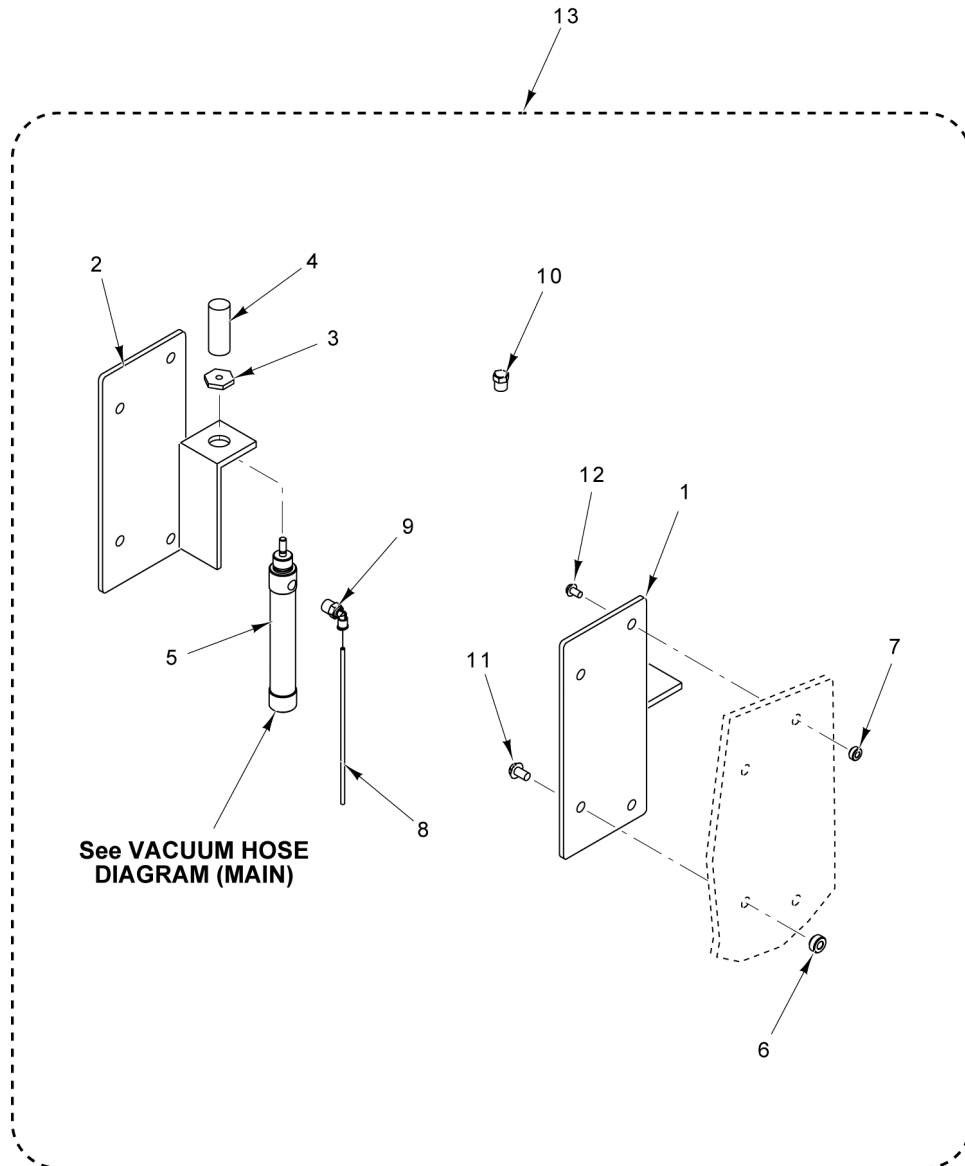

PL-60536

FILM SELECTOR AIR CYLINDERS

FILM SELECTOR AIR CYLINDERS

ILLUS.	PART NO.	NAME OF PART	AMT.
PL-60536			
1	00-446657	Bracket - Film Changer Cylinder (RH).....	1
2	00-446658	Bracket - Film Changer Cylinder (LH).....	1
3	NS-018-10	Jam Nut 5/16-24 Hex (SST).....	2
4	00-446659	Pusher - Film Changer Cylinder.....	2
5	00-446597	Cylinder - Film Changer.....	2
6	NS-048-40	Lock Nut 5/16-18 Flange (SST).....	2
7	NS-049-06	Lock Nut 1/4-20 (SST).....	6
8	00-444489-00001	Tubing - Natural Polyurethane (1/8).....	2
9	00-444121	Fitting - Elbow.....	2
10	00-042779	Plug.....	1
11	SC-129-51	Cap Screw 5/16-18 x 3/4 Hex Washer Hd. (SST).....	2
12	SC-129-49	Mach. Screw 1/4-20 x 1/2 Hex Washer Hd. (SST).....	6
13	00-446663	Kit - Cylinder Film Change (Incls. Items 1 thru 12).....	1

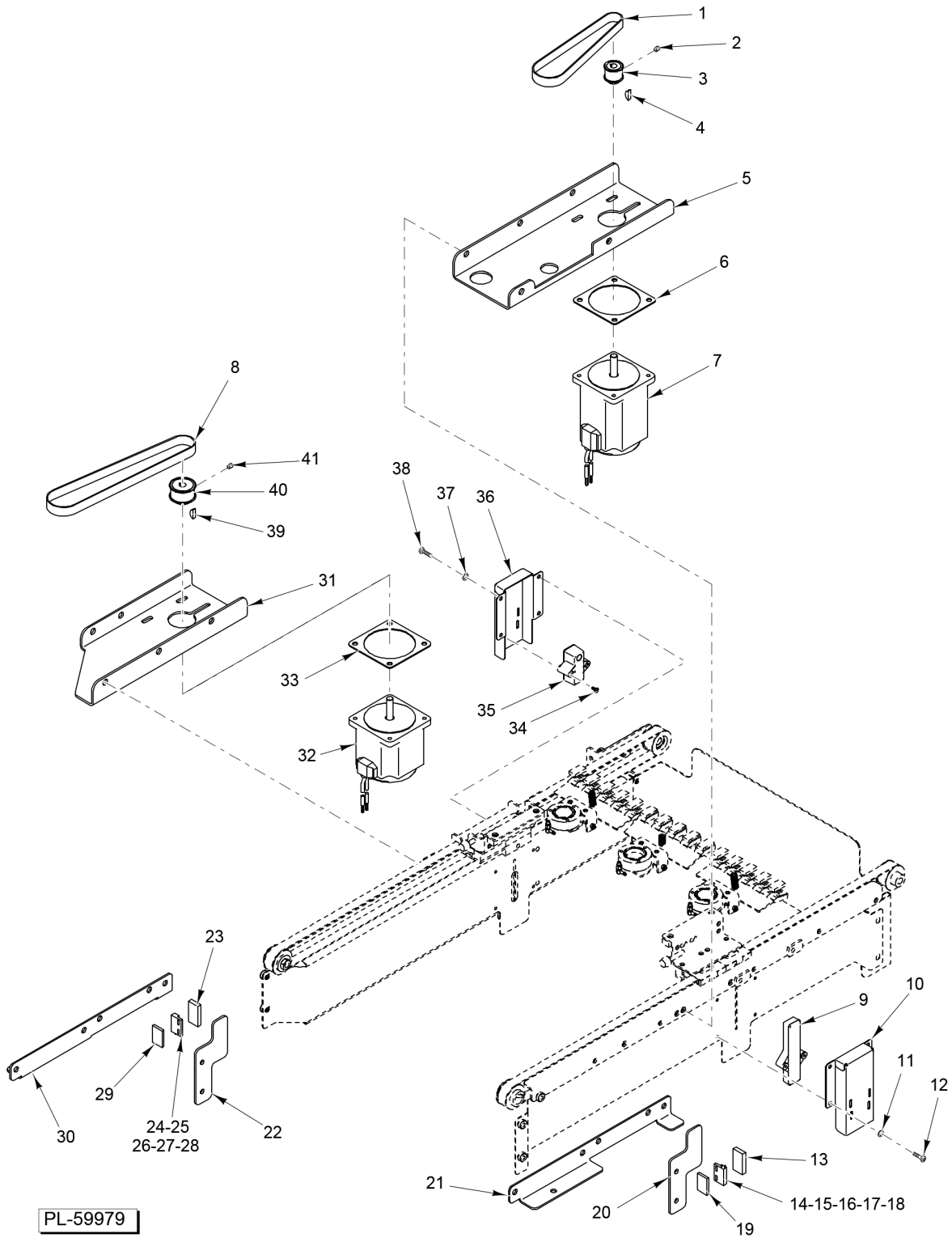

SIDE CLAMP AND SIDE UNDERFOLDER MOTORS

SIDE CLAMP AND SIDE UNDERFOLDER MOTORS

ILLUS. PL-59979	PART NO.	NAME OF PART	AMT.
1	00-445634	Belt (85T) (425mm) (Side Clamp).....	1
2	SC-125-19	Set Screw 10-32 x 1/4 Hex Hdls., Cup Pt. (SST).....	1
3	00-443860	Pulley (16T) (Incls. Item 2).....	1
4	KW-003-23	Key - Woodruff 3/32 x 5/8.....	1
5	00-444021	Bracket - Motor (RH).....	1
6	00-443963	Spacer - Motor Mounting.....	1
7	00-446003	Motor - Brushless (440 W.) (82 In. Motor Lead) (Side Clamp).....	1
8	00-446220	Belt (535mm) (107T) (Underfolder).....	1
9	00-444953	Sensor Assy. (Package).....	1
10	00-443814	Bracket - Elevator Sensor.....	1
11	WL-006-02	Lockwasher #8 Helical (SST).....	4
12	SC-093-04	Mach. Screw 8-32 x 1/2 Phil. Pan Hd. (SST).....	4
13	00-041725	Catch - Magnetic.....	1
14	00-443209	Interlock Harness Assy.....	1
15	00-183396	Plate - Screw Switch.....	1
16	SC-021-02	Mach. Screw 4-40 x 1/2 Slotted Rd. Hd. (SST).....	2
17	WS-029-24	Washer.....	2
18	WL-003-03	Lockwasher #4 Helical.....	2
19	00-175999	Actuator - Magnetic.....	1
20	00-444427	Stop - Door.....	2
21	00-443992	Frame (RH).....	1
22	00-444427	Stop - Door.....	1
23	00-041725	Catch - Magnetic.....	1
24	00-443209	Interlock Harness Assy.....	1
25	00-183396	Plate - Screw Switch.....	1
26	SC-021-02	Mach. Screw 4-40 x 1/2 Slotted Rd. Hd. (SST).....	2
27	WS-029-24	Washer.....	2
28	WL-003-03	Lockwasher #4 Helical.....	2
29	00-175999	Actuator - Magnetic.....	1
30	00-443991	Frame (LH).....	1
31	00-444020	Bracket - Motor (LH).....	1
32	00-446002	Motor - Brushless (220 W.) (82 In. Motor Lead) (Side Underfolder).....	1
33	00-443963	Spacer - Motor Mounting.....	1
34	SD-037-72	Self-Tapping Screw 6-19 x 1/2 Phil. Pan Hd.....	2
35	00-444954	Emitter Assy.....	1
36	00-443814	Bracket - Elevator Sensor.....	1
37	WL-006-02	Lockwasher #8 Helical (SST).....	4
38	SC-093-04	Mach. Screw 8-32 x 1/2 Phil. Pan Hd. (SST).....	4
39	KW-003-23	Key - Woodruff 3/32 x 5/8.....	1
40	00-443860	Pulley (16T) (Incls. Item 38).....	1
41	SC-125-19	Set Screw 10-32 x 1/4 Hex Hdls., Cup Pt. (SST).....	1

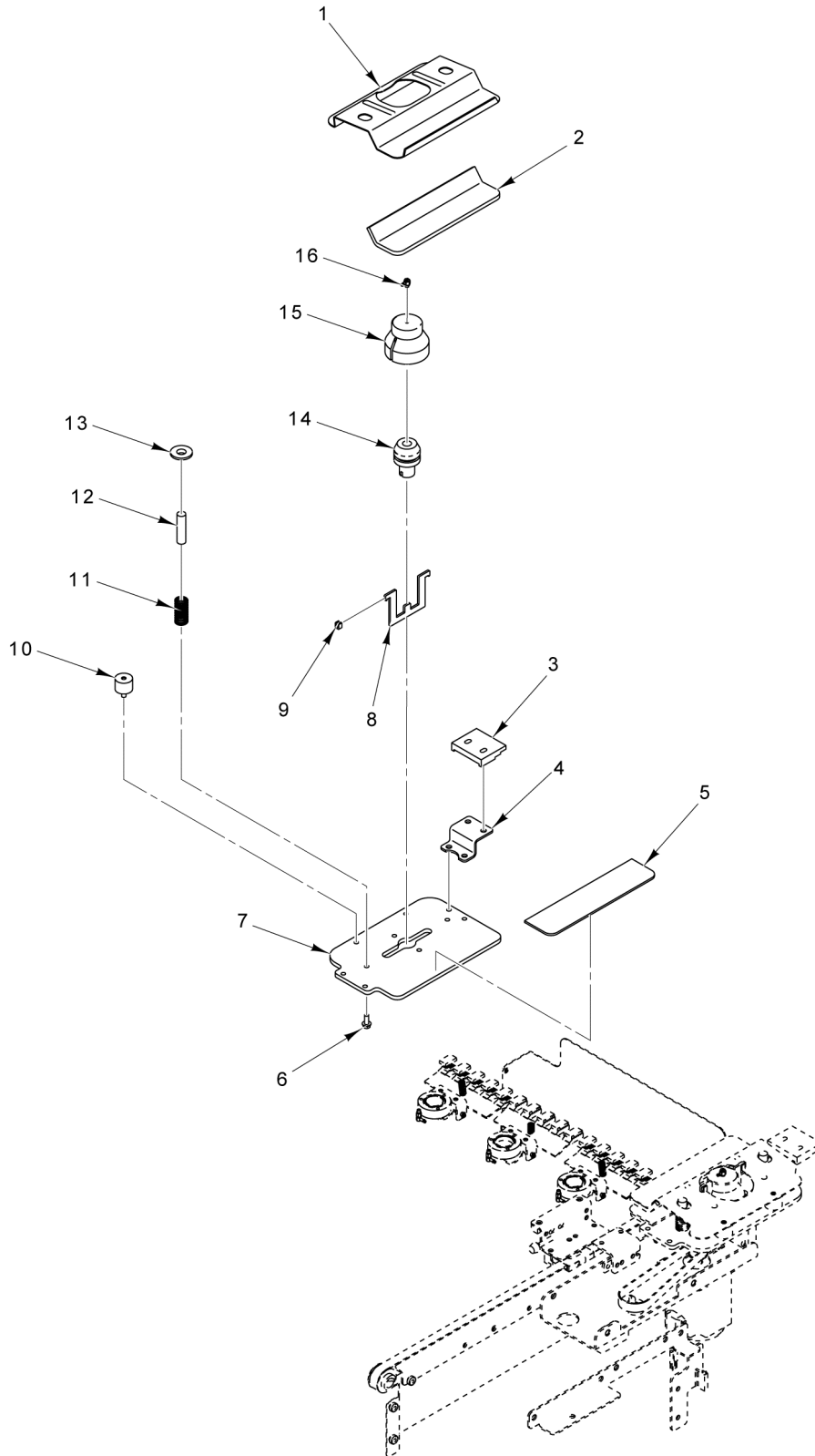

PL-60537

SIDE CLAMPS

SIDE CLAMPS

ILLUS.	PART NO.	NAME OF PART	AMT.
PL-60537			
1	00-447515	Clamp - Upper.....	2
2	00-447243	Pad - Clamp Upper.....	2
3	00-444046	Block - Clamp Slide.....	2
4	00-444045	Bracket - Slide Mounting.....	2
5	00-444003	Pad - Clamp Lower.....	2
6	SC-100-08	Mach. Screw 1/4-20 x 3/8 Hex Washer Hd.....	1
7	00-444026	Plate - Side Clamp.....	2
8	00-444009	Yoke.....	2
9	00-444039	Guide.....	2
10	00-444038	Mount - Hinge.....	2
11	00-444033	Spring - Clamp Return.....	2
12	00-444011	Stud.....	2
13	00-444010	Bushing.....	2
14	00-447234	Piston & Seal Assy.....	2
15	00-444007	Cylinder.....	2
16	00-444652	Fitting - Elbow 10-32 Adjustable.....	2

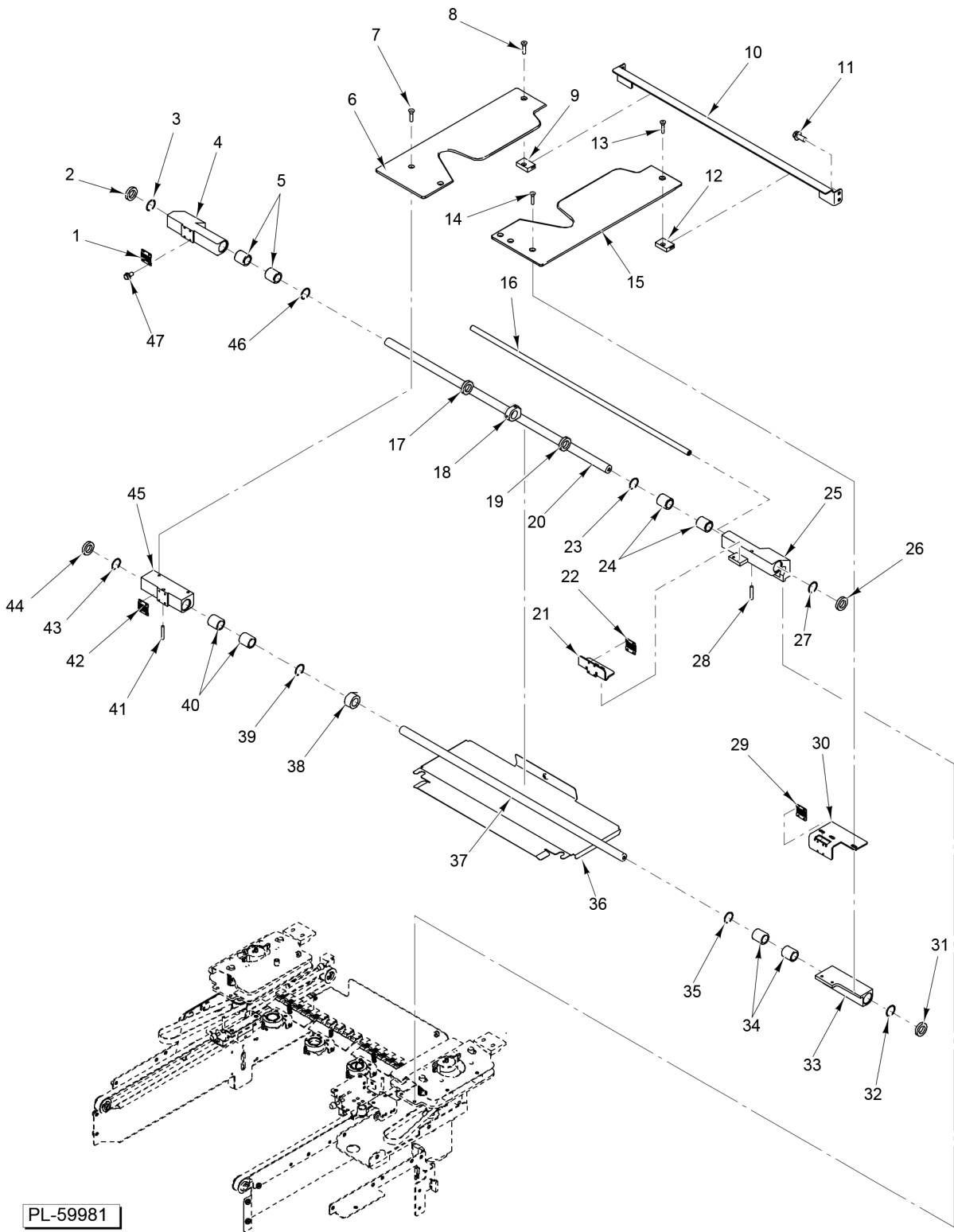

SIDE UNDERFOLDERS

SIDE UNDERFOLDERS

ILLUS.	PART NO.	NAME OF PART	AMT.
	PL-59981		
1	00-443906	Clamp - Belt.....	1
2	00-444047	Bumper - Clamp.....	1
3	00-444005	Ring - Retaining.....	1
4	00-444579	Housing Assy. - Clamp (LH) (Incls. Items 3, 5, & 46).....	1
5	00-444031	Bearing - Linear.....	2
6	00-445104	Underfolder (LH).....	1
7	SC-127-91	Mach. Screw 1/4-20 x 5/8 Phil. Flat Hd. (SST).....	4
8	SC-125-83	Mach. Screw 1/4-20 x 1/2 Phil. Flat Hd. (SST).....	1
9	00-444002	Slide.....	1
10	00-443984	Rail - Underfolder Rear.....	1
11	SC-129-49	Mach. Screw 1/4-20 x 1/2 Hex Washer Hd. (SST).....	4
12	00-444002	Slide.....	1
13	SC-125-83	Mach. Screw 1/4-20 x 1/2 Phil. Flat Hd. (SST).....	1
14	SC-125-83	Mach. Screw 1/4-20 x 1/2 Phil. Flat Hd. (SST).....	1
15	00-445105	Underfolder (RH).....	1
16	00-444035	Shaft - Unloader.....	1
17	00-444047	Bumper - Clamp.....	1
18	00-446043	Collar.....	1
19	00-444047	Bumper - Clamp.....	1
20	00-444006	Shaft.....	1
21	00-444036	Bracket - Belt Clamp.....	1
22	00-443906	Clamp - Belt.....	1
23	00-444005	Ring - Retaining.....	1
24	00-444031	Bearing - Linear.....	2
25	00-444578	Housing Assy. - Clamp (RH) (Incls. Items 23, 24, 27, & 28).....	1
26	00-444047	Bumper - Clamp.....	1
27	00-444005	Ring - Retaining.....	1
28	00-048624	Magnet.....	1
29	00-443906	Clamp - Belt.....	1
30	00-444019	Plate - Belt.....	1
31	00-444047	Bumper - Clamp.....	1
32	00-444005	Ring - Retaining.....	1
33	00-444580	Housing Assy. - Underfolder (RH) (Incls. Items 32, 34, & 35).....	1
34	00-444031	Bearing - Linear.....	2
35	00-444005	Ring - Retaining.....	1
36	00-445068	Cover - Belts.....	1
37	00-444006	Shaft.....	1
38	00-444034	Bumper - Slide.....	3
39	00-444005	Ring - Retaining.....	1
40	00-444031	Bearing - Linear.....	2
41	00-048624	Magnet.....	1
42	00-443906	Clamp - Belt.....	1
43	00-444005	Ring - Retaining.....	1
44	00-444047	Bumper - Clamp.....	1
45	00-444581	Housing Assy. - Underfolder (LH) (Incls. Items 39, 40, 41 & 43).....	1
46	00-444005	Ring - Retaining.....	1
47	SC-128-55	Mach. Screw 8-32 x 1/4 Hex Hd.....	4

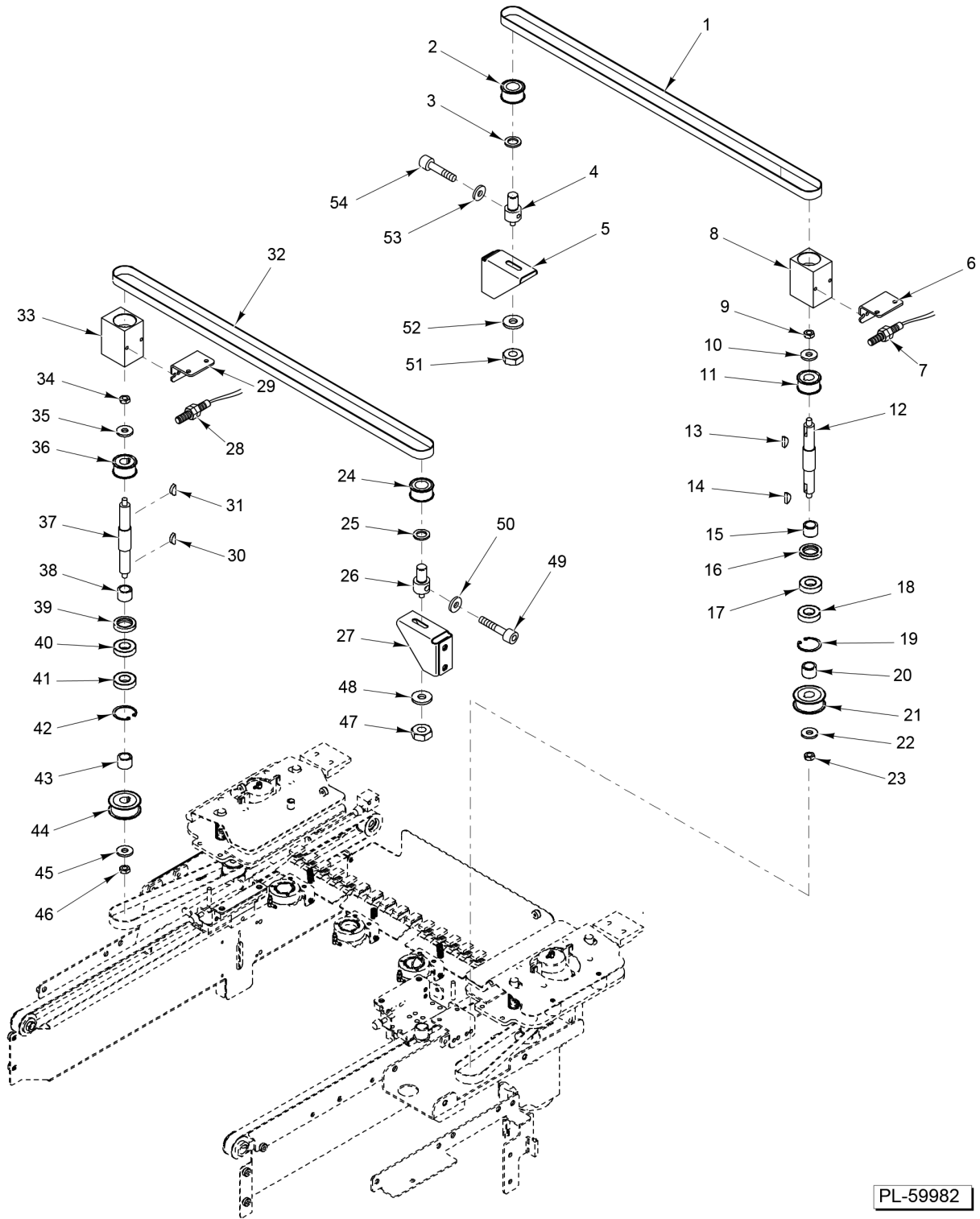

PL-59982

SIDE CLAMP, SIDE UNDERFOLDER BELTS, AND PULLEYS

SIDE CLAMP, SIDE UNDERFOLDER BELTS, AND PULLEYS

ILLUS. PL-59982	PART NO.	NAME OF PART	AMT.
1	00-445635	Belt - Timing (284T) (Side Underfolder).....	1
2	00-443867	Pulley Assy. - Idler.....	1
3	00-444025	Washer - Thrust.....	1
4	00-444024	Stud - Idler.....	1
5	00-444023	Bracket Assy. - Idler.....	1
6	00-444030	Bracket - Sensor Mounting.....	1
7	00-446021	Sensor - Position.....	1
8	00-444015	Housing - Bearing.....	1
9	NS-018-18	Jam Nut 3/8-24 Hex (SST).....	1
10	WS-018-40	Washer (SST).....	1
11	00-443864	Pulley (22T).....	1
12	00-444016	Shaft.....	1
13	KW-003-10	Key - Woodruff 3/16 x 3/4.....	1
14	KW-003-10	Key - Woodruff 3/16 x 3/4.....	1
15	00-444017	Spacer.....	1
16	00-444018	Seal - Shaft.....	1
17	00-443950	Bearing (Type 57PP).....	1
18	00-443950	Bearing (Type 57PP).....	1
19	RR-012-01	Retaining Ring.....	1
20	00-444017	Spacer.....	1
21	00-443869	Pulley (30T).....	1
22	WS-018-40	Washer (SST).....	1
23	NS-018-18	Jam Nut 3/8-24 Hex (SST).....	1
24	00-443867	Pulley Assy. - Idler.....	1
25	00-444025	Washer - Thrust.....	1
26	00-444024	Stud - Idler.....	1
27	00-444023	Bracket Assy. - Idler.....	1
28	00-446021	Sensor - Position.....	1
29	00-444030	Bracket - Sensor Mounting.....	1
30	KW-003-10	Key - Woodruff 3/16 x 3/4.....	1
31	KW-003-10	Key - Woodruff 3/16 x 3/4.....	1
32	00-445635	Belt - Timing (284T) (Side Clamp).....	1
33	00-444015	Housing - Bearing.....	1
34	NS-018-18	Jam Nut 3/8-24 Hex (SST).....	1
35	WS-018-40	Washer (SST).....	1
36	00-443864	Pulley (22T).....	1
37	00-444016	Shaft.....	1
38	00-444017	Spacer.....	1
39	00-444018	Seal - Shaft.....	1
40	00-443950	Bearing (Type 57PP).....	1
41	00-443950	Bearing (Type 57PP).....	1
42	RR-012-01	Retaining Ring.....	1
43	00-444017	Spacer.....	1
44	00-443869	Pulley (30T).....	1
45	WS-018-40	Washer (SST).....	1
46	NS-018-18	Jam Nut 3/8-24 Hex (SST).....	1
47	NS-048-40	Lock Nut 5/16-18 Flange (SST).....	1
48	WS-028-37	Washer (SST).....	1
49	SC-129-54	Cap Screw 5/16-18 x 2-3/4 Hex Socket Hd. (SST).....	1
50	WS-017-09	Washer (SST).....	1
51	NS-048-40	Lock Nut 5/16-18 Flange (SST).....	1
52	WS-028-37	Washer (SST).....	1
53	WS-017-09	Washer (SST).....	1
54	SC-129-54	Cap Screw 5/16-18 x 2-3/4 Hex Socket Hd. (SST).....	1
	00-444517	Bearing Shaft Assy. (Incls. Items 8 thru 23 OR 30, 31, & 33 thru 46).....	1

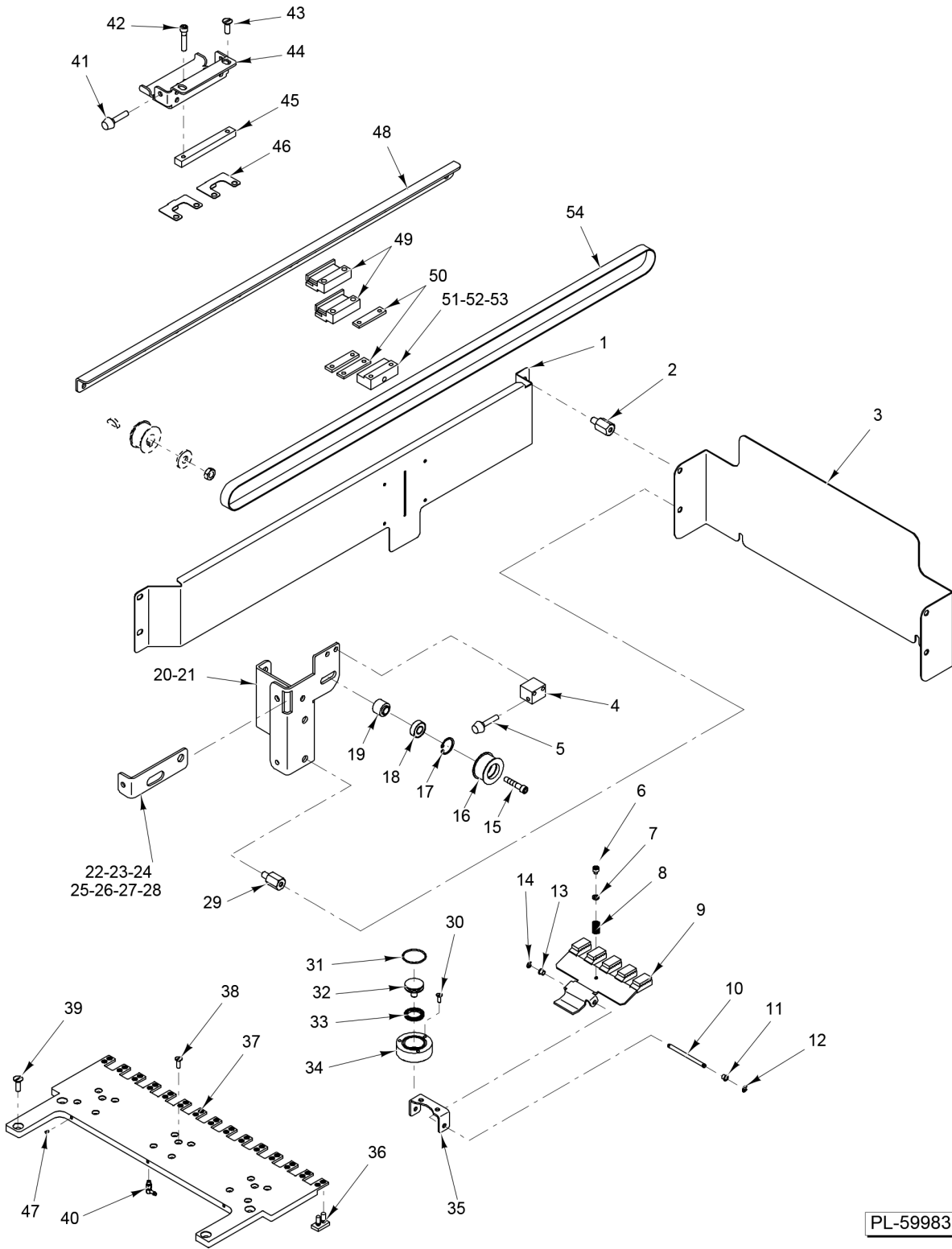

PL-59983

GRIPPER AND GRIPPER DRIVE BELT

GRIPPER AND GRIPPER DRIVE BELT

ILLUS.	PART NO.	NAME OF PART	AMT.
1	00-443815	Shield (LH).....	1
2	00-444356	Stud - Guide.....	2
3	00-446742	NLA - Obsolete--Stop - Package.....	1
4	00-444369	Block - Bumper.....	2
5	00-443742	Bumper.....	2
6	SC-129-48	Cap Screw 10-32 x 3/16 Hex Socket Hd. (SST).....	1
7	WL-006-07	Lockwasher #10 Helical (SST).....	1
8	00-444985	Spring - Gripper Opening.....	1
9	00-445863	Plate Assy. (Lower).....	3
10	00-443914	Shaft - Gripper Pivot.....	1
11	00-183765	Bearing - Nyliner.....	1
12	RR-012-29	Retaining Ring.....	1
13	00-183765	Bearing - Nyliner.....	1
14	RR-012-29	Retaining Ring.....	1
15	SC-059-39	Cap Screw 3/8-16 x 1-1/2 Hex Washer Hd. (SST).....	1
16	00-443866	Pulley - Idler (Incls. Items 17 & 18).....	2
17	RR-012-32	Retaining Ring.....	2
18	00-443943	Bearing - Ball.....	2
19	00-444366	Spacer - Idler.....	2
20	00-446171	Bracket - Rail Support (RH).....	1
21	00-446170	Bracket - Rail Support (LH).....	1
22	00-445326	Spring - Weigher Belt.....	2
23	SC-131-25	Cap Screw 1/4-20 x 3-1/2 Hex Hd. (SST).....	2
24	00-446133	Bracket Assy. (LH).....	1
25	00-446134	Bracket Assy. (RH).....	1
26	00-258300-00004	Standoff.....	1
27	SC-119-51	Mach. Screw 6-32 x 1 Slotted Pan Hd. (SST).....	1
28	NS-009-07	Nut 6-32 Hex.....	1
29	00-444356	Stud - Guide.....	2
30	SC-114-97	Mach. Screw 10-24 x 3/4 Slotted Flat Hd.....	2
31	00-441580-00004	O-Ring.....	1
32	00-443921	Piston.....	1
33	00-443922	Seal - Piston.....	1
34	00-445021	Cylinder.....	1
35	00-443924	Bracket - Pivot.....	1
36	00-043452	Pad - Gripper (Gray) (Set of 15).....	1
37	00-443923	Plate - Gripper.....	1
38	SC-129-80	Mach. Screw 10-24 x 3/4 Phil. Flat Hd. (SST).....	15
39	SC-022-33	Mach. Screw 1/4-20 x 3/4 Slotted Flat Hd. (SST).....	4
40	00-443913	Fitting - Elbow.....	3
41	00-443742	Bumper.....	1
42	SC-125-07	Cap Screw 1/4-20 x 1-1/4 Hex Socket Hd. (SST).....	2
43	SC-022-40	Mach. Screw 1/4-20 x 3/4 Phil. Flat Hd. (SST).....	2
44	00-445930	Bracket - Gripper Slide.....	1
45	00-444049	Plate - Nut.....	1
46	00-443926	Clip.....	2
47	SC-046-07	Set Screw 8-32 x 1/4 Slotted Hdls., Cup Pt.....	3
48	00-444364	Rail - Gripper.....	1
49	00-446831	Block - Belt Mounting.....	4
50	00-443930	Plate - Nut.....	3
51	00-446762	Block Assy. - Gripper & Pusher (Incls. Items 52 & 53).....	1
52	00-443917	Block - Magnet.....	1
53	00-443938	Magnet.....	1
54	00-446072-00004	Belt - Pusher (Cut to Length, 277T = 54 1/2 In.) (Gripper).....	1
	00-913102-00162	Kit - Bracket Rail (LH) (Incls. Items 22, 23, 24, 26, 27, & 28).....	1
	00-913102-00167	Kit - Bracket Rail (RH) (Incls. Items 22, 23, & 25 thru 28).....	1
	SC-123-92	Mach. Screw 1/4-20 x 5/8 Hex Washer Hd.....	2

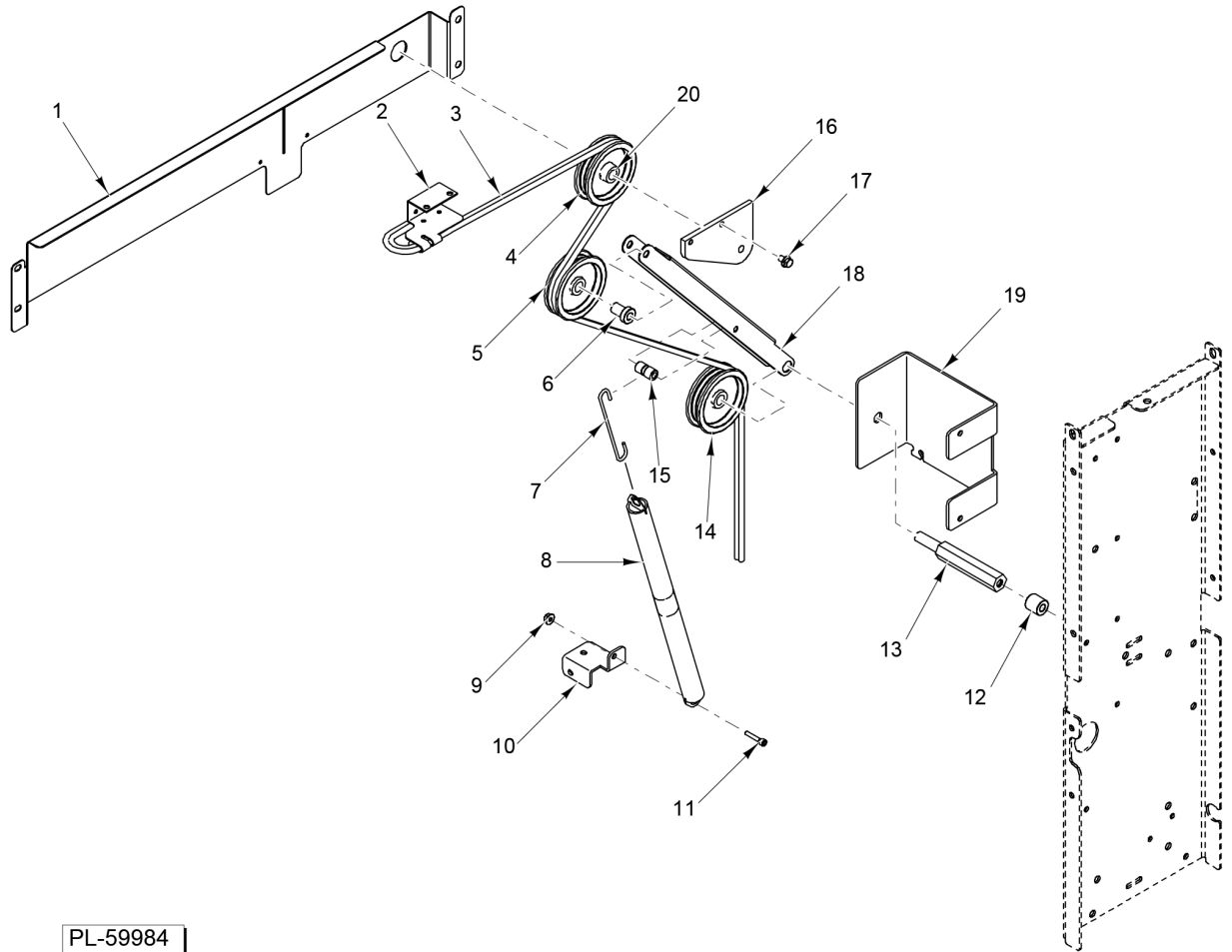

PL-59984

GRIPPER SPRING ASSEMBLY

GRIPPER SPRING ASSEMBLY

ILLUS.	PART NO.	NAME OF PART	AMT.
PL-59984			
1	00-445056	Shield - Right.....	1
2	00-447786	Bracket - Gripper Hose.....	1
3	00-913102-00159	Tubing (With Connector).....	1
4	00-444904	Pulley - Gripper Hose.....	1
5	00-444904	Pulley - Gripper Hose.....	1
6	00-444902	Bushing - Gripper Pulley.....	1
7	00-445042	Hook - Spring.....	1
8	00-049043	Spring Assy. - Pulldown.....	1
9	NS-049-06	Lock Nut 1/4-20 (SST).....	2
10	00-444901	Bracket - Gripper Spring.....	1
11	SC-041-03	Cap Screw 1/4-20 x 1-1/8 Hex Hd. (SST).....	1
12	00-444899	Spacer - Short Gripper Pulley.....	1
13	00-444898	Spacer - Gripper Pulley.....	1
14	00-444904	Pulley - Gripper Hose.....	1
15	00-444905	Spacer - Torsion Spring.....	1
16	00-444897	Plate - Pulley.....	1
17	SC-100-08	Mach. Screw 1/4-20 x 3/8 Hex Washer Hd.....	1
18	00-444895	Gripper Arm - Hose Take Up.....	1
19	00-444896	Bracket - Pivot Arm.....	1
20	00-445041	Bushing.....	1

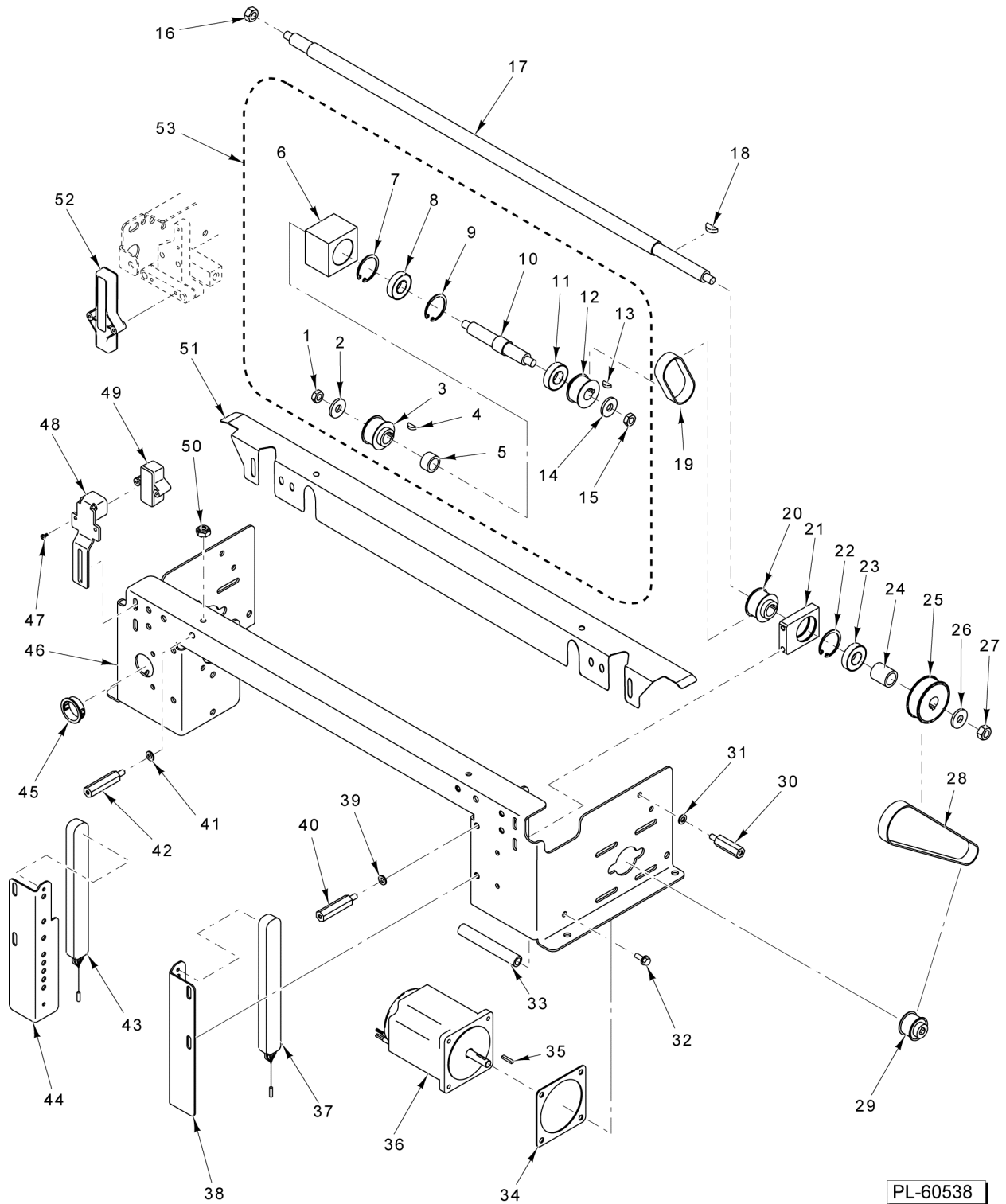

GRIPPER DRIVE, SEALER BELT SENSORS, AND HEIGHT SENSORS

GRIPPER DRIVE, SEALER BELT SENSORS, AND HEIGHT SENSORS

ILLUS. PL-60538	PART NO.	NAME OF PART	AMT.
1	NS-018-18	Jam Nut 3/8-24 Hex (SST).....	1
2	WS-018-40	Washer (SST).....	1
3	00-443865	Pulley (22T).....	1
4	KW-004-05	Key - Woodruff 3/16 x 3/4 (SST).....	1
5	00-444360	Spacer.....	1
6	00-444362	Block - Bearing.....	2
7	RR-012-01	Retaining Ring.....	1
8	00-443950	Bearing.....	1
9	RR-012-01	Retaining Ring.....	1
10	00-444361	Shaft.....	1
11	00-443950	Bearing.....	1
12	00-443865	Pulley (22T).....	1
13	KW-004-05	Key - Woodruff 3/16 x 3/4 (SST).....	1
14	WS-018-40	Washer (SST).....	1
15	NS-018-18	Jam Nut 3/8-24 Hex (SST).....	1
16	NS-018-18	Jam Nut 3/8-24 Hex (SST).....	1
17	00-444357	Shaft - Gripper Drive.....	1
18	KW-004-05	Key - Woodruff 3/16 x 3/4 (SST).....	2
19	00-446215	Belt (200mm).....	2
20	00-443865	Pulley (22T).....	2
21	00-444370	Block - Bearing.....	2
22	RR-012-01	Retaining Ring.....	2
23	00-443950	Bearing.....	2
24	00-444358	Spacer.....	1
25	00-443871	Pulley (34T).....	1
26	WS-018-40	Washer (SST).....	1
27	NS-018-18	Jam Nut 3/8-24 Hex (SST).....	1
28	00-446216	Belt (450mm) (90T).....	1
29	00-443862	Pulley (18T).....	1
30	00-444448	Standoff - Side Cover.....	1
31	WL-003-38	Lockwasher 1/4 Helical.....	1
32	SC-129-49	Mach. Screw 1/4-20 x 1/2 Hex Washer Hd. (SST).....	2
33	00-446089	Spacer.....	1
34	00-443963	Spacer - Motor Mounting.....	1
35	KW-003-23	Key - Woodruff 3/32 x 5/8.....	1
36	00-446003	Motor - Brushless (440 W.) (82 In. Motor Lead) (Gripper Drive).....	1
37	00-447421	Height Detector Assy. (RH) (Red Wire).....	1
38	00-443817	Bracket - Height Sensor (RH).....	1
39	WL-003-38	Lockwasher 1/4 Helical.....	1
40	00-444447	Standoff - Front Cover.....	1
41	WL-003-38	Lockwasher 1/4 Helical.....	1
42	00-444447	Standoff - Front Cover.....	1
43	00-447422	Height Detector Assy. (LH) (Black Wire).....	1
44	00-443818	Bracket - Height Sensor (LH).....	1
45	FE-026-29	Bushing - Electrical Snap.....	1
46	00-443983	Bracket - Front.....	1
47	SD-037-72	Self-Tapping Screw 6-19 x 1/2 Phil. Pan Hd.....	2
48	00-443813	Bracket - LED Mount.....	1
49	00-444954	Emitter Assy. (Sealer Belt).....	1
50	00-444198	Mount - Sealer Rear.....	2
51	00-445470	Guide - Belt.....	1
52	00-444953	Sensor Assy. (Package) (Receiver).....	1
53	00-444359	Block Assy. - Bearing (Incls. Items 1 thru 15).....	2

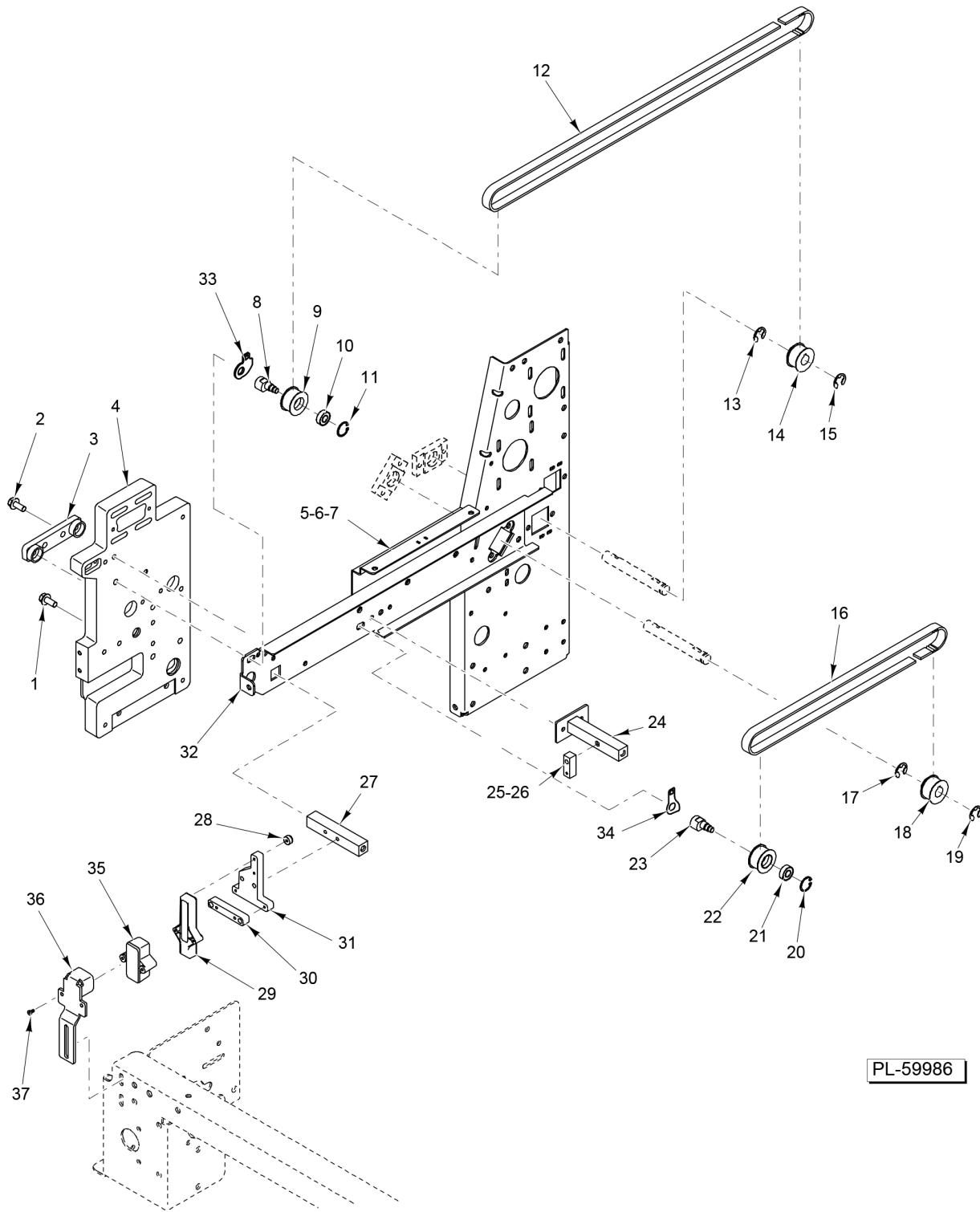

LEFT FRONT FOLDER AND SEALER BELT PACKAGE SENSOR

LEFT FRONT FOLDER AND SEALER BELT PACKAGE SENSOR

ILLUS. PL-59986	PART NO.	NAME OF PART	AMT.
1	00-444426	Screw - Cover Shoulder.....	2
2	SC-129-51	Cap Screw 5/16-18 x 3/4 Hex Washer Hd. (SST).....	2
3	00-444044	Mount - Slide Rods.....	1
4	00-443989	Support - Printer Display (LH).....	1
5	00-445118	Bracket - Upper Cover.....	1
6	00-175998	Sensor.....	1
7	00-183396	Plate - Screw Switch.....	1
8	00-446025	Shaft - Idler.....	1
9	00-443866	Pulley - Idler (Incls. Items 10 & 11).....	1
10	00-443943	Bearing - Ball.....	1
11	RR-012-32	Retaining Ring.....	1
12	00-446072-00004	Belt - Pusher (Cut to Length, 277T = 54-1/2 In.).....	2
13	RR-012-04	Retaining Ring.....	1
14	00-443865	Pulley (22T).....	1
15	RR-012-04	Retaining Ring.....	1
16	00-446072-00004	Belt - Pusher (Cut to Length, 175T = 34-7/16 In.).....	2
17	RR-012-04	Retaining Ring.....	1
18	00-443865	Pulley (22T).....	1
19	RR-012-04	Retaining Ring.....	1
20	RR-012-32	Retaining Ring.....	1
21	00-443943	Bearing - Ball.....	1
22	00-443866	Pulley - Idler (Incls. Items 20 & 21).....	1
23	00-446025	Shaft - Idler.....	1
24	00-444395	Standoff.....	1
25	00-444075	Block - Stop.....	1
26	00-444076	Bumper.....	1
27	00-444094	Standoff.....	1
28	00-444076	Bumper.....	1
29	00-444953	Sensor Assy. (Package).....	1
30	00-444086	Bar - Spacer.....	1
31	00-444085	Mount - Block Stop Sensor.....	1
32	00-443982	Frame Assy. - Upper Left.....	1
33	00-446018	Plate - Adjusting (Upper Pusher).....	1
34	00-446017	Plate - Adjusting (Rear Underfolder).....	1
35	00-444954	Emitter Assy. (Sealer Belt).....	1
36	00-443813	Bracket - LED Mount.....	1
37	SD-037-72	Self-Tapping Screw 6-19 x 1/2 Phil. Pan Hd.....	2
	00-446038	Kit - Rail Repair.....	AR
	00-446039	Kit - Rail Support.....	AR

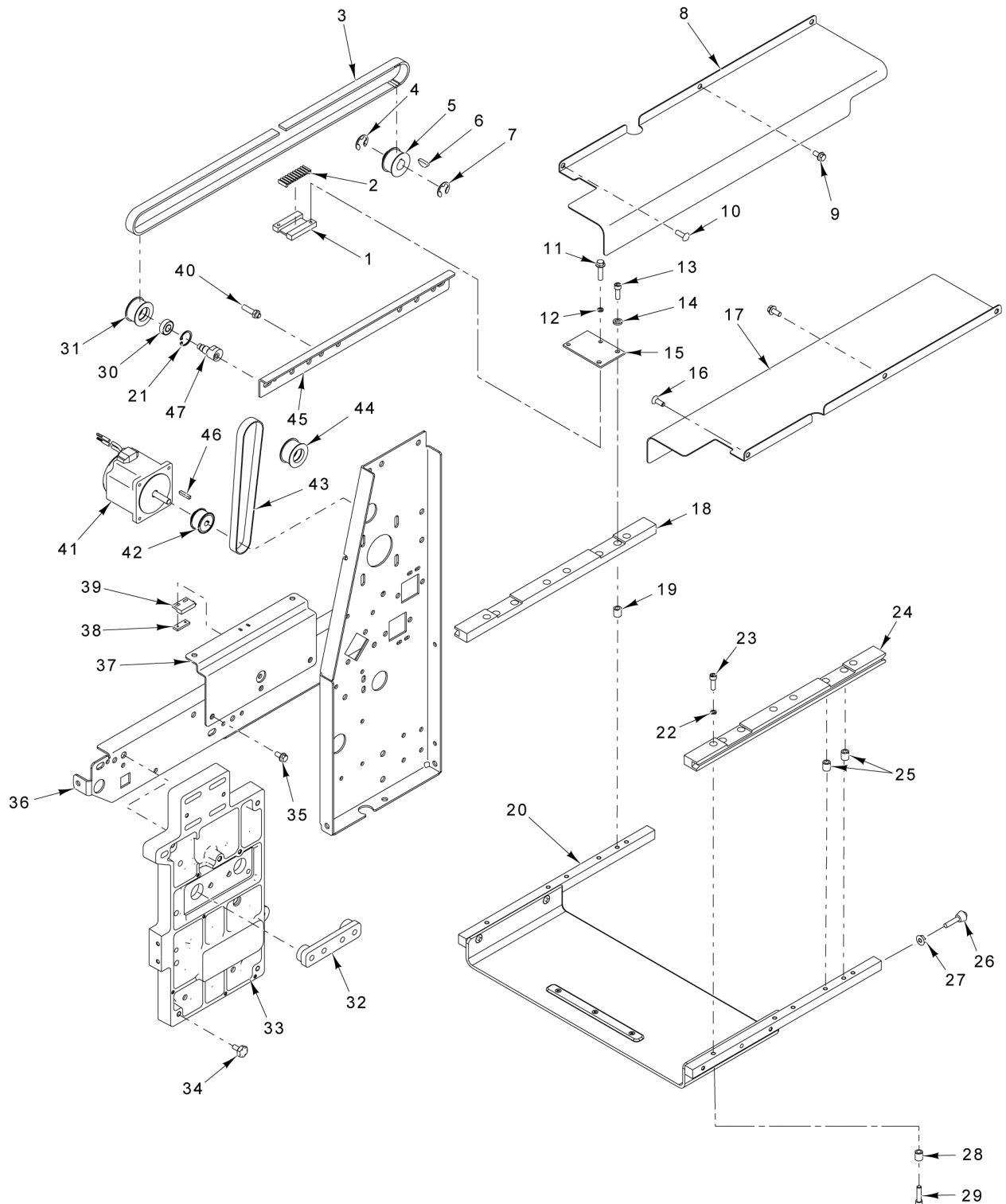

PL-60539

RIGHT FRONT FOLDER, SHUTTLE, AND REAR UNDERFOLDER MOTOR

RIGHT FRONT FOLDER, SHUTTLE, AND REAR UNDERFOLDER MOTOR

ILLUS.	PART NO.	NAME OF PART	AMT.
1	00-444096	Block - Belt Clamp.....	1
2	00-443929	Retainer - Belt.....	1
3	00-446072-00004	Belt - Pusher (Cut to Length, 232T = 45-5/8 In.).....	2
4	RR-012-04	Retaining Ring.....	1
5	00-443865	Pulley (22T).....	1
6	KW-004-05	Key - Woodruff 3/16 x 3/4 (SST).....	1
7	RR-012-04	Retaining Ring.....	1
8	00-443998	Shield - Belt Left.....	1
9	SC-129-49	Mach. Screw 1/4-20 x 1/2 Hex Washer Hd. (SST).....	4
10	SC-129-50	Mach. Screw 1/4-20 x 5/8 Hex Washer Hd. (SST).....	1
11	SC-116-32	Cap Screw 10-32 x 3/8 Hex Hd. (SST).....	2
12	WL-006-07	Lockwasher #10 Helical (SST).....	2
13	SC-059-30	Cap Screw 1/4-20 x 1 Hex Socket Hd. (SST).....	4
14	WL-006-17	Lockwasher 1/4 Helical (SST).....	4
15	00-444095	Bracket.....	1
16	SC-129-50	Mach. Screw 1/4-20 x 5/8 Hex Washer Hd. (SST).....	1
17	00-443999	Shield - Belt Right.....	1
18	00-444092	Slide - Front Folder.....	1
19	00-444615	Spacer Assy. - Shuttle.....	4
20	00-447280	Folder - Front Assy.....	1
21	RR-012-24	Retaining Ring.....	1
22	WL-020-06	Lockwasher 1/4 Helical (SST).....	4
23	SC-110-98	Cap Screw 1/4-20 x 3/4 Hex Socket Hd. (SST).....	4
24	00-444092	Slide - Front Folder.....	1
25	00-444615	Spacer Assy. - Shuttle.....	8
26	00-443742	Bumper.....	1
27	NS-049-06	Lock Nut 1/4-20 (SST).....	1
28	00-444615	Spacer Assy. - Shuttle.....	2
29	SC-059-30	Cap Screw 1/4-20 x 1 Hex Socket Hd. (SST).....	2
30	00-443943	Bearing - Ball.....	1
31	00-443866	Pulley - Idler (Incls. Items 48 & 49).....	1
32	00-444044	Mount - Slide Rods.....	1
33	00-443990	Support - Printer Display (RH).....	1
34	00-444426	Screw - Cover Shoulder.....	2
35	SC-129-51	Cap Screw 5/16-18 x 3/4 Hex Washer Hd. (SST).....	3
36	00-443981	NLA - Obsolete--Frame - Upper Right Rear.....	1
37	00-445118	Bracket - Upper Cover.....	1
38	00-183396	Plate - Screw Switch.....	1
39	00-443209	Interlock Harness Assy.....	1
40	00-446021	Sensor - Position (Home/Limit).....	1
41	00-446014	Motor - Brushless (220 W.) (120 In. Motor Lead) (Rear Underfolder).....	1
42	00-443860	Pulley (16T) (Drive) (Rear Underfolder).....	1
43	00-446216	Belt (450mm) (90T).....	1
44	00-444752	Pulley (36T) (Driven) (Rear Underfolder).....	1
45	00-446024	Rail - Front Folder.....	1
46	KW-003-23	Key - Woodruff 3/32 x 5/8.....	1
47	00-446025	Shaft - Idler.....	1

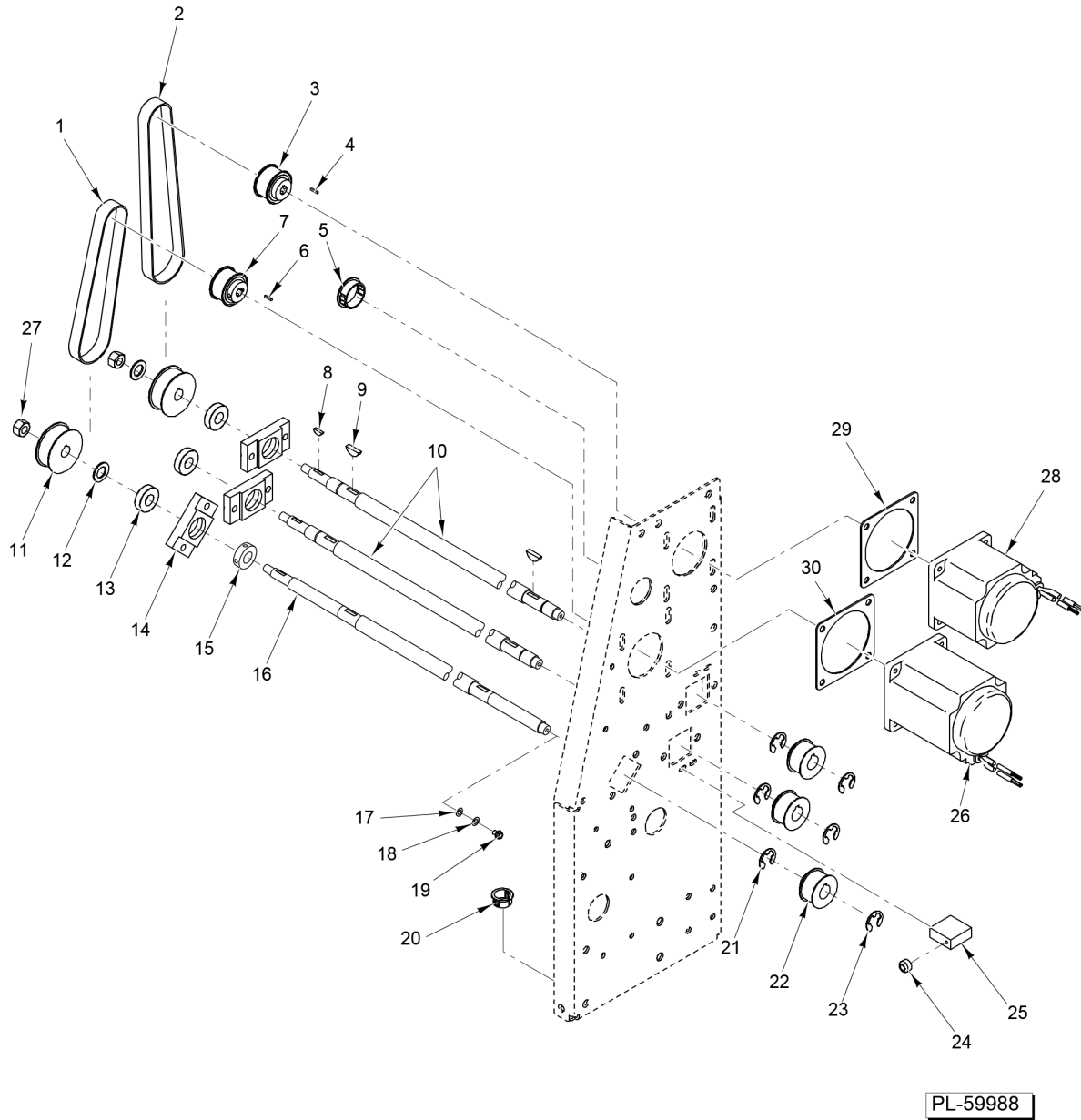

PL-59988

UPPER PUSHER AND FRONT FOLDER MOTORS

UPPER PUSHER AND FRONT FOLDER MOTORS

ILLUS.	PART NO.	NAME OF PART	AMT.
1	00-445634	Belt (85T) (Front Folder Drive).....	1
2	00-446219	Belt - Pusher (500mm) (Upper Pusher Drive).....	1
3	00-443860	Pulley (16T).....	1
4	KW-003-23	Key - Woodruff 3/32 x 5/8.....	1
5	FE-026-29	Bushing - Electrical Snap.....	1
6	KW-003-23	Key - Woodruff 3/32 x 5/8.....	1
7	00-443863	Pulley (22T).....	1
8	KW-003-04	Key 1/8 x 1/2.....	3
9	KW-004-05	Key - Woodruff 3/16 x 3/4 (SST).....	6
10	00-446074	Shaft - Pusher/Rear Underfolder.....	2
11	00-443870	Pulley (30T).....	2
12	WS-008-48	Washer (SST).....	3
13	00-444077	Bearing - Sealed.....	3
14	00-444084	Block - Bearing.....	3
15	00-446082	Collar (Use With Item 16).....	2
16	00-446075	Shaft (Front Underfolder).....	1
17	WS-022-02	Washer 0.266 x 0.688 x 0.062 (SST).....	1
18	WS-029-40	Washer (SST).....	1
19	SC-129-49	Mach. Screw 1/4-20 x 1/2 Hex Washer Hd. (SST).....	1
20	FE-016-24	Bushing - Electrical Split.....	1
21	RR-012-04	Retaining Ring.....	3
22	00-443865	Pulley (22T).....	3
23	RR-012-04	Retaining Ring.....	3
24	00-444076	Bumper.....	1
25	00-444450	Block - Stop.....	1
26	00-446408	Motor - Brushless (440 W.) (Front Underfolder) (120 In. Motor Lead) (Front Underfolder).....	1
27	NS-038-10	Lock Nut 3/8-16 Hex.....	2
28	00-446014	Motor - Brushless (220 W.) (120 In. Motor Lead) (Upper Pusher).....	1
29	00-443963	Spacer - Motor Mounting.....	1
30	00-443963	Spacer - Motor Mounting.....	1

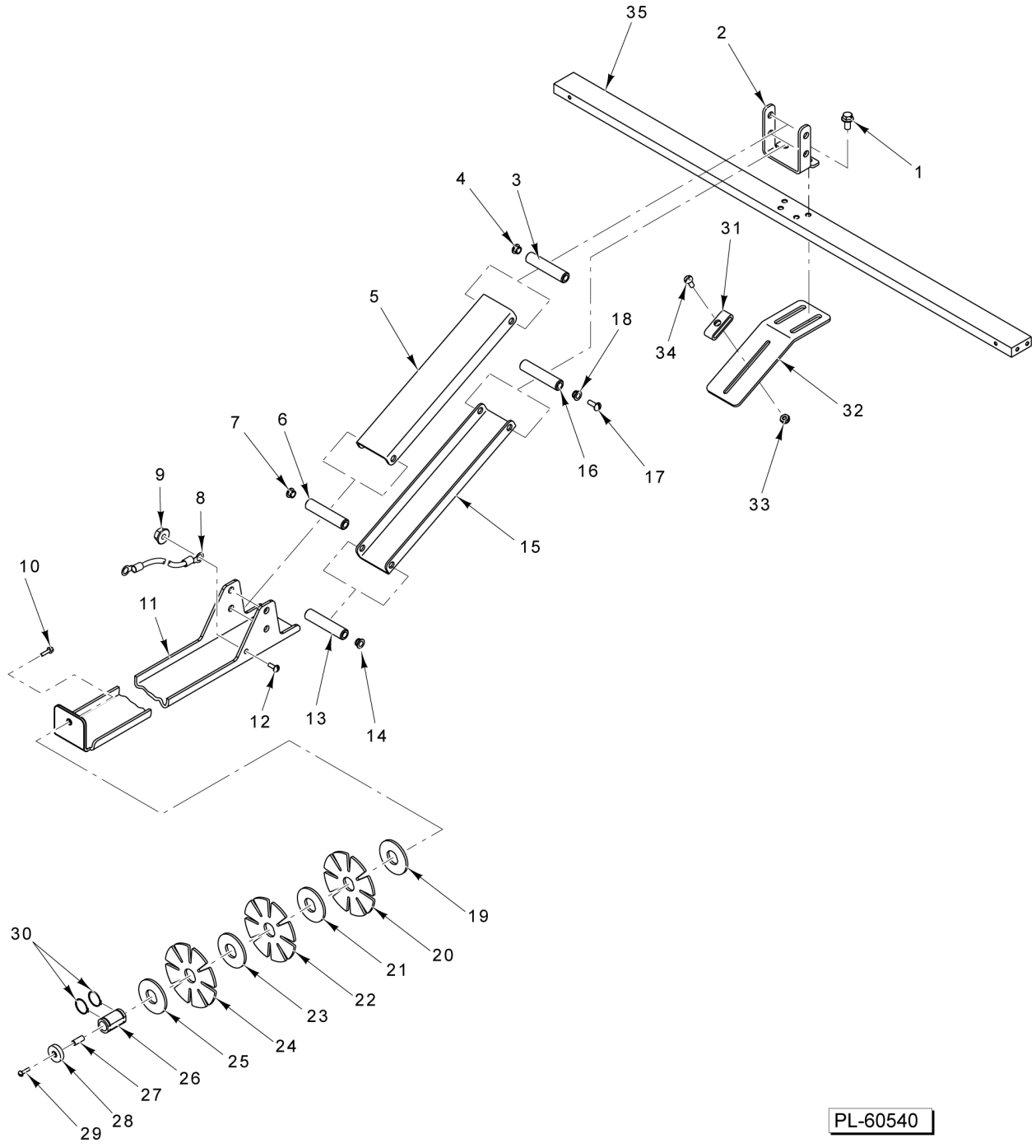

PL-60540

**PACKAGE HOLD DOWN
(ML-44230 & ML-44231)**

**PACKAGE HOLD DOWN
(ML-44230 & ML-44231)**

ILLUS. PL-60540	PART NO.	NAME OF PART	AMT.
1	SC-129-49	Mach. Screw 1/4-20 x 1/2 Hex Washer Hd. (SST).....	2
2	00-444926	Bracket - Hold Down Mount.....	1
3	00-445398	Pin - Hold Down Pivot.....	1
4	00-175560	Bushing - Nyliner.....	4
5	00-444923	Arm - Hold Down.....	4
6	00-445398	Pin - Hold Down Pivot.....	1
7	00-175560	Bushing - Nyliner.....	4
8	00-445106	Cable Assy. - Ground.....	1
9	NS-049-06	Lock Nut 1/4-20 (SST).....	1
10	SC-129-49	Mach. Screw 1/4-20 x 1/2 Hex Washer Hd. (SST).....	1
11	00-445113	Hold Down.....	1
12	SC-053-41	Mach. Screw 1/4-20 x 1/2 Slotted Truss Hd. (SST).....	1
13	00-445398	Pin - Hold Down Pivot.....	1
14	00-175560	Bushing - Nyliner.....	4
15	00-444923	Arm - Hold Down.....	1
16	00-445398	Pin - Hold Down Pivot.....	1
17	SC-053-05	Mach. Screw 10-24 x 3/8 Slotted Truss Hd. (SST).....	8
18	00-175560	Bushing - Nyliner.....	4
19	00-445037	Spacer.....	1
20	00-445036	Disk - Roller.....	1
21	00-445037	Spacer.....	1
22	00-445036	Disk - Roller.....	1
23	00-445037	Spacer.....	1
24	00-445036	Disk - Roller.....	1
25	00-445037	Spacer.....	1
26	00-445038	Core - Roller.....	1
27	00-444915	Shaft - Roller.....	1
28	00-445067	Cap - Roller.....	1
29	SC-053-41	Mach. Screw 1/4-20 x 1/2 Slotted Truss Hd. (SST).....	1
30	RR-011-03	Retaining Ring.....	2
31	00-334272	Bumper.....	1
32	00-444139	Bracket - Bumper Mount.....	1
33	NS-031-49	Stop Nut 10-32 Hex (SST).....	1
34	SC-093-07	Mach. Screw 10-32 x 1/2 Slotted Pan Hd. (SST).....	1
35	00-443979	Bar - Hold Down.....	1

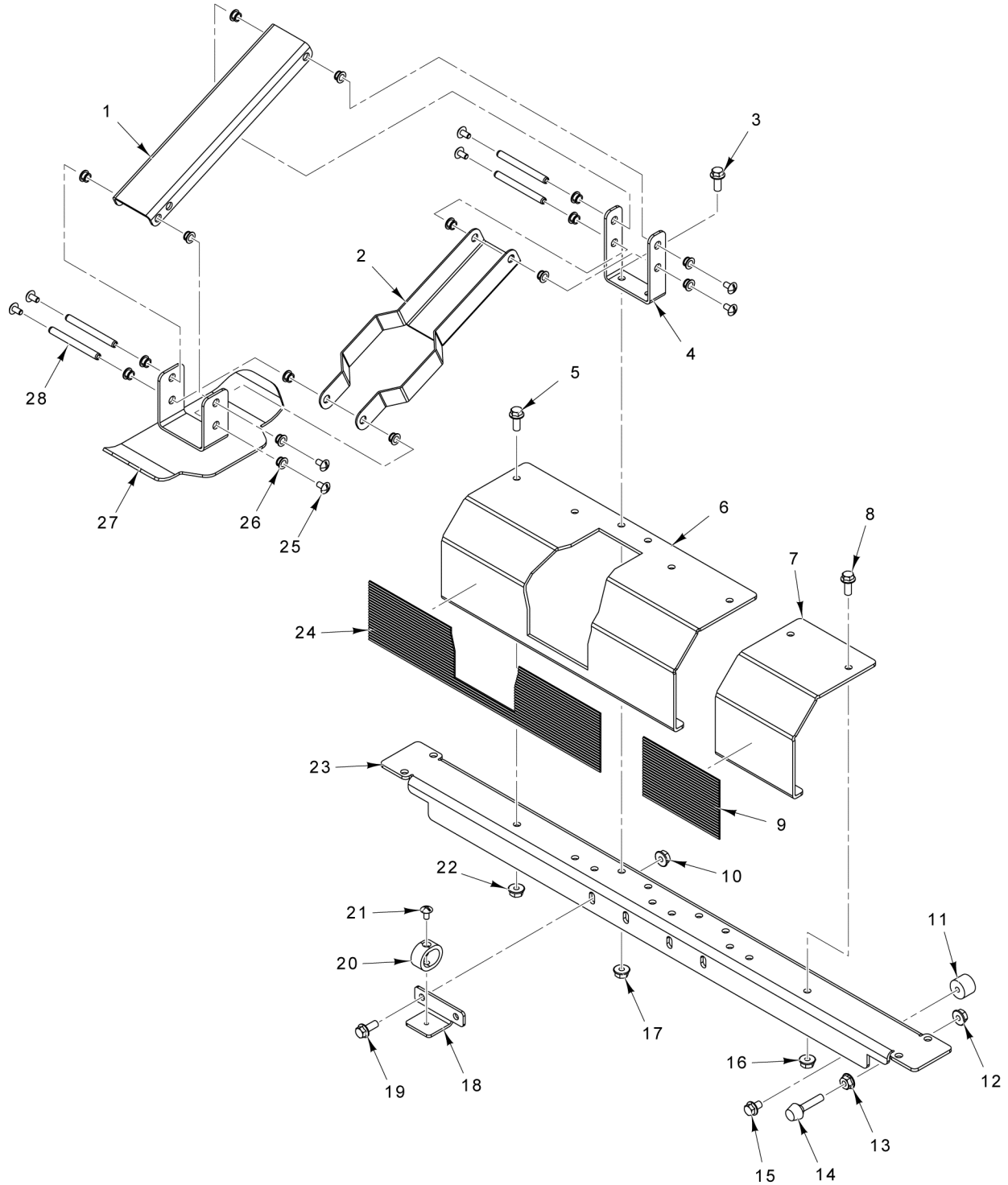

PL-60541

**PUSHER AND HOLD DOWN
(COSTCO)
(ML-44233 & ML-44234)**

**PUSHER AND HOLD DOWN
(COSTCO)
(ML-44233 & ML-44234)**

ILLUS. PL-60541	PART NO.	NAME OF PART	AMT.
1	00-444923	Arm - Hold Down.....	1
2	00-446647	Arm - Hold Down.....	1
3	SC-129-50	Mach. Screw 1/4-20 x 5/8 Hex Washer Hd. (SST).....	2
4	00-446646	Bracket - Hold Down.....	1
5	SC-129-50	Mach. Screw 1/4-20 x 5/8 Hex Washer Hd. (SST).....	4
6	00-446643	Pusher.....	1
7	00-446644	Pusher.....	1
8	SC-129-50	Mach. Screw 1/4-20 x 5/8 Hex Washer Hd. (SST).....	2
9	00-446704	Pad - Pusher.....	1
10	NS-049-06	Lock Nut 1/4-20 (SST).....	2
11	00-446667	Bumper.....	2
12	NS-049-06	Lock Nut 1/4-20 (SST).....	2
13	NS-049-06	Lock Nut 1/4-20 (SST).....	2
14	00-443742	Bumper.....	2
15	SC-100-08	Mach. Screw 1/4-20 x 3/8 Hex Washer Hd.....	2
16	NS-049-06	Lock Nut 1/4-20 (SST).....	2
17	NS-049-06	Lock Nut 1/4-20 (SST).....	2
18	00-446645	Bracket - Bumper.....	1
19	SC-129-50	Mach. Screw 1/4-20 x 5/8 Hex Washer Hd. (SST).....	2
20	00-334272	Bumper.....	1
21	SC-053-05	Mach. Screw 10-24 x 3/8 Slotted Truss Hd. (SST).....	1
22	NS-049-06	Lock Nut 1/4-20 (SST).....	4
23	00-446642	Brace - Pusher.....	1
24	00-446703	Pad - Pusher.....	1
25	SC-053-05	Mach. Screw 10-24 x 3/8 Slotted Truss Hd. (SST).....	8
26	00-175560	Bushing - Nyliner.....	16
27	00-446648	Plate Assy.....	1
28	00-445398	Pin - Hold Down Pivot.....	4

- 50 00-443220 Motor
- 51 00-446002 Motor
- 52 00-443860 Pulley (16T)
- 53 00-446216 Belt

PARTS NOT ILLUSTRATED

**ML-44230
AND
ML-44231**

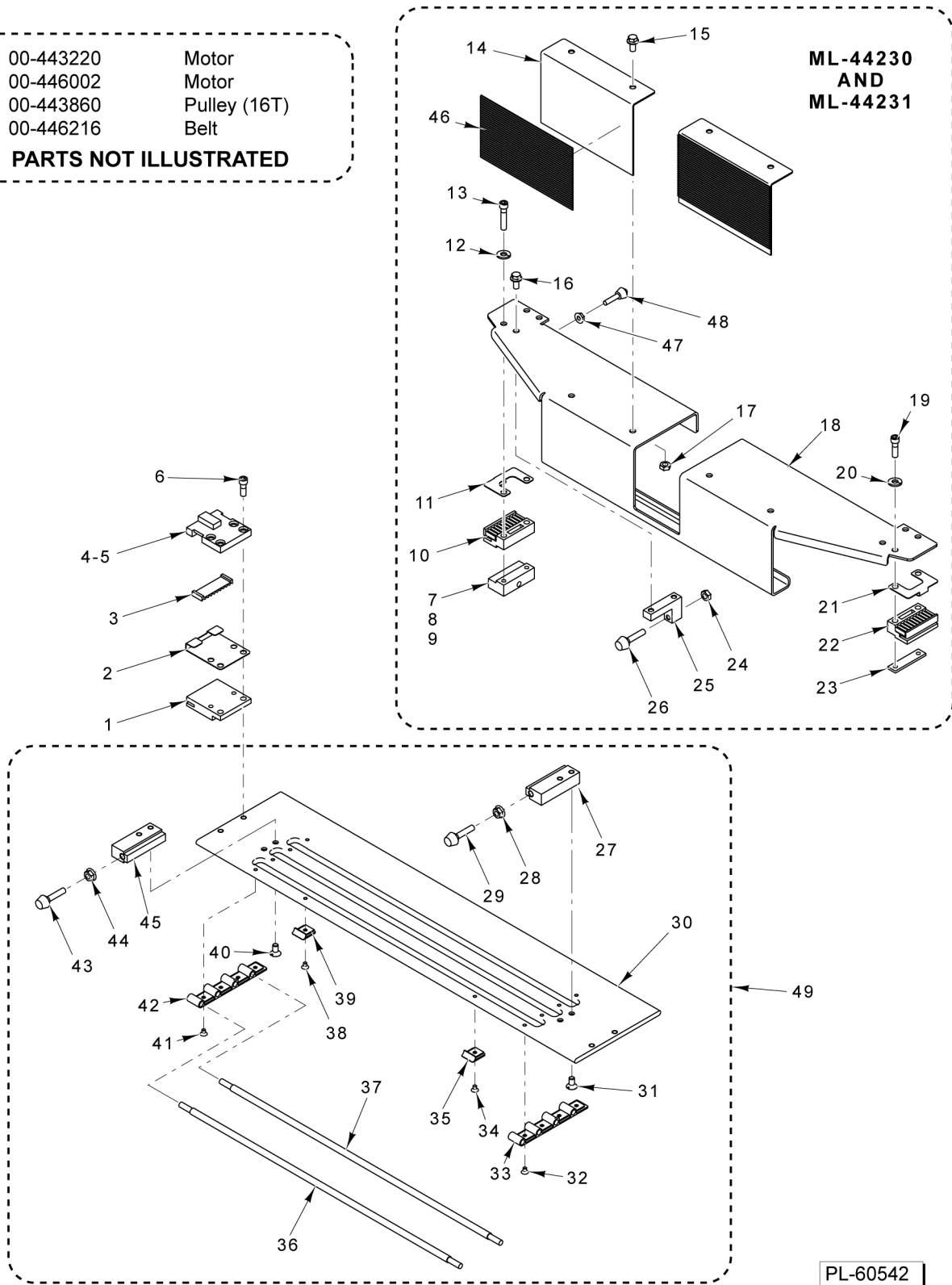

PUSHER AND REAR UNDERFOLDER

PUSHER AND REAR UNDERFOLDER

ILLUS. PL-60542	PART NO.	NAME OF PART	AMT.
1	00-444079	Block - Slide.....	1
2	00-444083	Clip - Belt Retainer.....	1
3	00-443929	Retainer - Belt.....	1
4	00-446760	Block Assy. - Rear Underfolder (Incls. Item 5).....	2
5	00-444082	Block - Clamp (Rear Underfolder).....	1
6	SC-110-98	Cap Screw 1/4-20 x 3/4 Hex Socket Hd. (SST).....	1
7	00-446762	Block Assy. - Gripper & Pusher (Incls. Items 8 & 9) (ML-44230 & ML-44231).....	1
8	00-443917	Block - Magnet (Upper Pusher) (ML-44230 & ML-44231).....	1
9	00-443938	Magnet (ML-44230 & ML-44231).....	1
10	00-446831	Block - Belt Mounting (ML-44230 & ML-44231).....	1
11	00-443926	Clip (ML-44230 & ML-44231).....	1
12	WL-006-17	Lockwasher 1/4 Helical (SST) (ML-44230 & ML-44231).....	2
13	SC-125-07	Cap Screw 1/4-20 x 1-1/4 Hex Socket Hd. (SST) (ML-44230 & ML-44231).....	2
14	00-444844	Plate (ML-44230 & ML-44231).....	2
15	SC-129-49	Mach. Screw 1/4-20 x 1/2 Hex Washer Hd. (SST) (ML-44230 & ML-44231).....	4
16	SC-129-49	Mach. Screw 1/4-20 x 1/2 Hex Washer Hd. (SST) (ML-44230 & ML-44231).....	4
17	NS-049-06	Lock Nut 1/4-20 (SST) (ML-44230 & ML-44231).....	4
18	00-444839	Pusher (ML-44230 & ML-44231).....	1
19	SC-129-85	Cap Screw 1/4-20 x 7/8 Hex Socket Hd. (SST) (ML-44230 & ML-44231).....	2
20	WL-006-17	Lockwasher 1/4 Helical (SST) (ML-44230 & ML-44231).....	2
21	00-443926	Clip (ML-44230 & ML-44231).....	1
22	00-446831	Block - Belt Mounting (ML-44230 & ML-44231).....	1
23	00-443930	Plate - Nut (ML-44230 & ML-44231).....	1
24	NS-049-06	Lock Nut 1/4-20 (SST) (ML-44230 & ML-44231).....	2
25	00-443974	Block - Stop (ML-44230 & ML-44231).....	2
26	00-443742	Bumper (ML-44230 & ML-44231).....	2
27	00-445417	Mount - Stop.....	1
28	NS-049-06	Lock Nut 1/4-20 (SST).....	1
29	00-443742	Bumper.....	1
30	00-445415	Underfolder - Rear.....	1
31	SC-127-91	Mach. Screw 1/4-20 x 5/8 Phil. Flat Hd. (SST).....	2
32	SC-119-14	Mach. Screw 8-32 x 1/4 Phil. Flat Hd. (SST).....	4
33	00-446818	Roller Mount (End).....	1
34	SC-119-14	Mach. Screw 8-32 x 1/4 Phil. Flat Hd. (SST).....	1
35	00-446819	Roller Mount (Center).....	1
36	00-444927	Roller - Underfolder.....	1
37	00-445416	Roller - Underfolder.....	3
38	SC-119-14	Mach. Screw 8-32 x 1/4 Phil. Flat Hd. (SST).....	1
39	00-446819	Roller Mount (Center).....	1
40	SC-127-91	Mach. Screw 1/4-20 x 5/8 Phil. Flat Hd. (SST).....	2
41	SC-119-14	Mach. Screw 8-32 x 1/4 Phil. Flat Hd. (SST).....	4
42	00-446818	Roller Mount (End).....	1
43	00-443742	Bumper.....	1
44	NS-049-06	Lock Nut 1/4-20 (SST).....	1
45	00-445417	Mount - Stop.....	1
46	00-443975	Pad - Pusher (ML-44230 & ML-44231).....	2
47	NS-049-06	Lock Nut 1/4-20 (SST) (ML-44230 & ML-44231).....	2
48	00-443742	Bumper (ML-44230 & ML-44231).....	2
49	00-445414	Underfolder Assy. (Incls. Items 27 thru 45).....	1
50	00-443220	Motor - Brushless (220 W.) (21 In. Motor Lead).....	1
51	00-446002	Motor - Brushless (220 W.) (82 In. Motor Lead).....	1
52	00-443860	Pulley (16T).....	1
53	00-446216	Belt (450mm) (90T) (Gripper Rear Folder).....	1

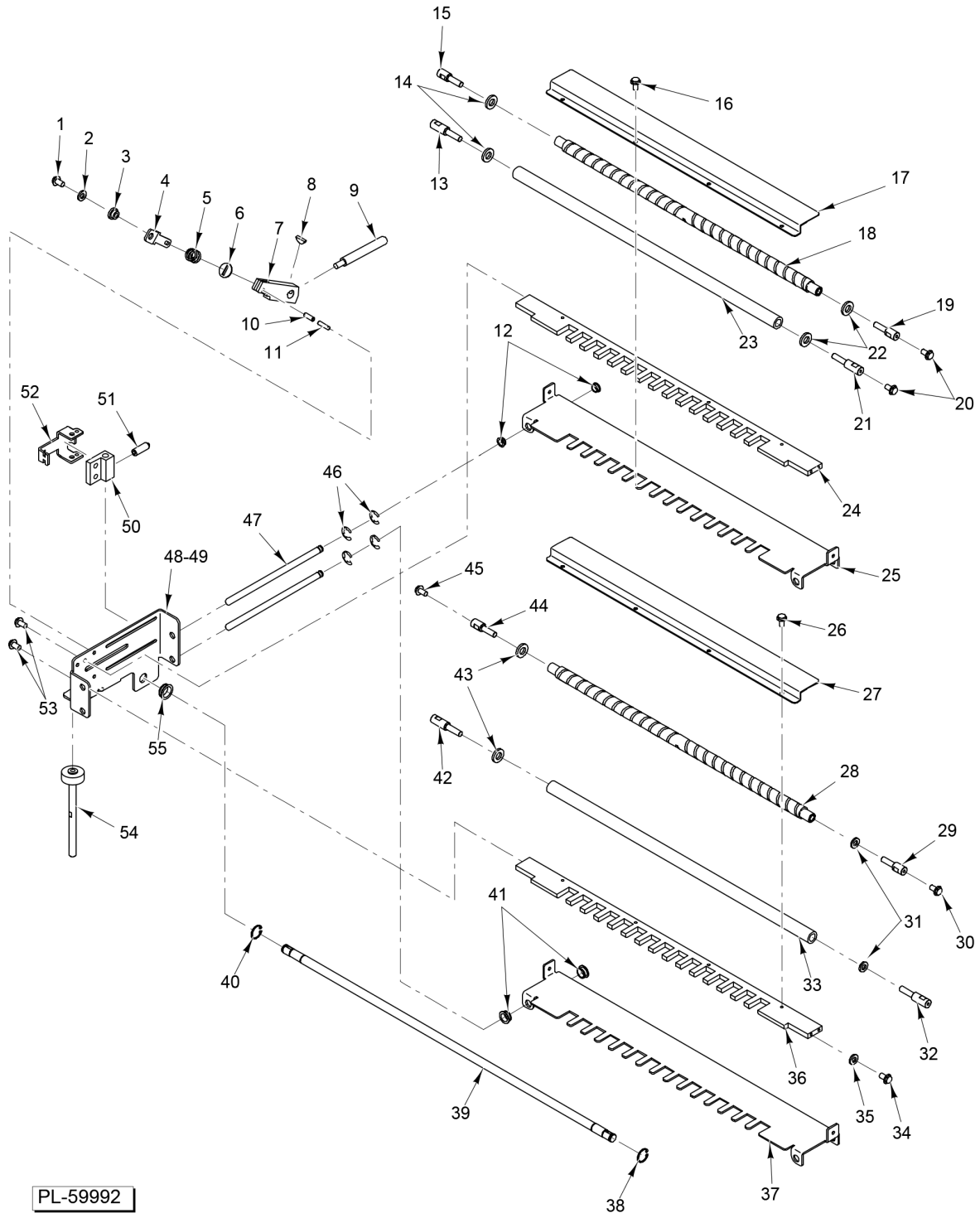

FILM SELECTOR

FILM SELECTOR

ILLUS. PL-59992	PART NO.	NAME OF PART	AMT.
1	SC-067-13	Mach. Screw 10-32 x 1/2 Slotted Hex Hd. (SST).....	1
2	WL-006-07	Lockwasher #10 Helical (SST).....	1
3	00-444271	Bushing.....	1
4	00-444272	Link - Latch.....	1
5	00-444273	Spring - Latch.....	1
6	00-444270	Washer.....	1
7	00-444259	Link - Latch.....	1
8	KW-003-04	Key 1/8 x 1/2.....	2
9	00-444261	Handle.....	1
10	RP-006-04	Pin - Roll (0.187).....	2
11	RP-006-41	Pin - Roll.....	1
12	00-041488	Bearing (Nyliner).....	4
13	00-444268	Stud - Film Roller (Front).....	1
14	00-444264	Washer.....	1
15	00-444267	Stud - Film Roller (Rear).....	1
16	SC-116-32	Cap Screw 10-32 x 3/8 Hex Hd. (SST).....	4
17	00-445491	Separator - Film Changer.....	1
18	00-445278	Roller Assy. (Rubber).....	1
19	00-444267	Stud - Film Roller (Rear).....	1
20	SC-067-13	Mach. Screw 10-32 x 1/2 Slotted Hex Hd. (SST).....	2
21	00-444268	Stud - Film Roller (Front).....	1
22	00-444264	Washer.....	2
23	00-444263	Roller Assy. - Film Selector.....	1
24	00-444253	Guide - Film.....	1
25	00-444269	Guide - Lower.....	1
26	SC-116-32	Cap Screw 10-32 x 3/8 Hex Hd. (SST).....	4
27	00-445491	Separator - Film Changer.....	1
28	00-445278	Roller Assy. (Rubber).....	1
29	00-444267	Stud - Film Roller (Rear).....	1
30	SC-067-13	Mach. Screw 10-32 x 1/2 Slotted Hex Hd. (SST).....	1
31	00-444264	Washer.....	2
32	00-444268	Stud - Film Roller (Front).....	1
33	00-444263	Roller Assy. - Film Selector.....	1
34	SC-067-13	Mach. Screw 10-32 x 1/2 Slotted Hex Hd. (SST).....	2
35	WL-006-07	Lockwasher #10 Helical (SST).....	2
36	00-444253	Guide - Film.....	1
37	00-444269	Guide - Lower.....	1
38	RR-010-12	Retaining Ring.....	3
39	00-444258	Shaft - Latch.....	1
40	RR-010-12	Retaining Ring.....	3
41	00-041488	Bearing (Nyliner).....	4
42	00-444268	Stud - Film Roller (Front).....	1
43	00-444264	Washer.....	2
44	00-444267	Stud - Film Roller (Rear).....	1
45	SC-067-13	Mach. Screw 10-32 x 1/2 Slotted Hex Hd. (SST).....	1
46	RR-009-10	Retaining Ring 3/8 In. (SST).....	4
47	00-444257	Shaft - Slide.....	2
48	00-444255-00002	Bracket - Support (LH).....	1
49	00-444255-00001	Bracket - Support (RH).....	1
50	00-445127	Block - Roller Adjust.....	4
51	SC-055-25	Set Screw 1/4-20 x 1 Hdls.....	4
52	00-445126	Bracket - Latch.....	2
53	SC-067-13	Mach. Screw 10-32 x 1/2 Slotted Hex Hd. (SST).....	2
54	00-445350	Rod - Selector Assy.....	1
55	00-043411	Bearing (Nyliner).....	1
	00-443396	Ground Strap.....	1

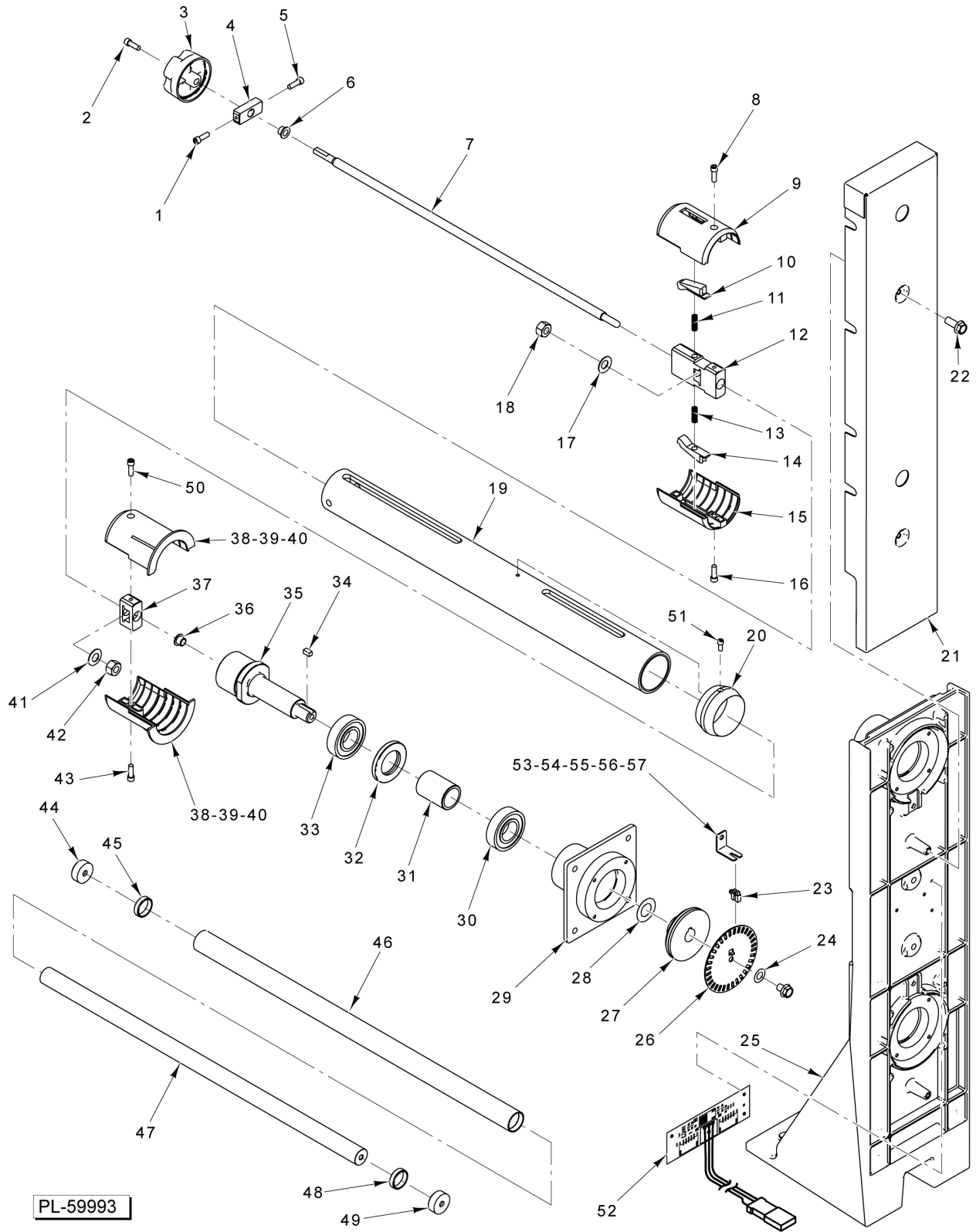

FILM SUPPLY ARBOR

FILM SUPPLY ARBOR

ILLUS.	PART NO.	NAME OF PART	AMT.
1	SC-059-29	Cap Screw 1/4-20 x 1/2 Hex Socket Hd. (SST).....	1
2	SC-123-92	Mach. Screw 1/4-20 x 5/8 Hex Washer Hd.....	1
3	00-444161	Knob - Film Supply.....	1
4	00-444158	Hub - Supply Shaft.....	1
5	SC-059-29	Cap Screw 1/4-20 x 1/2 Hex Socket Hd. (SST).....	1
6	00-442611-00008	Bushing - Sleeve.....	1
7	00-444168	Shaft - Film Supply.....	1
8	SC-059-29	Cap Screw 1/4-20 x 1/2 Hex Socket Hd. (SST).....	1
9	00-444159	Collar - Retainer.....	1
10	00-444164	Retainer - Film Supply.....	1
11	00-444162	Spring.....	1
12	00-444169	Hub - Retainer Film Supply.....	1
13	00-444162	Spring.....	1
14	00-444164	Retainer - Film Supply.....	1
15	00-444159	Collar - Retainer.....	1
16	SC-059-29	Cap Screw 1/4-20 x 1/2 Hex Socket Hd. (SST).....	1
17	00-444481	Washer - Spring.....	1
18	NS-049-05	Nut 1/2-13 Hex (SST).....	1
19	00-444170	Tube Assy. - Film Supply (Incls. Items 35 & 36).....	1
20	00-444165	Sleeve - Film Shaft.....	1
21	00-443996	Cover - Film Supply.....	1
22	SC-129-49	Mach. Screw 1/4-20 x 1/2 Hex Washer Hd. (SST).....	2
23	00-443223	Sensor Assy. - Film Detect.....	2
24	WS-018-40	Washer (SST).....	1
25	00-444148	Support - Film Supply.....	1
26	00-444153	Disc - Sensor.....	1
27	00-444146	Brake Assy.....	1
28	00-444986-00003	Shim - Brake.....	1
29	00-444147	Housing - Bearing.....	1
30	00-444144	Bearing - Film Supply.....	1
31	00-445050	Spacer - Bearing.....	1
32	00-445051	Seal - Shaft.....	1
33	00-444144	Bearing - Film Supply.....	1
34	00-444479	Key.....	1
35	00-444171	Arbor - Film Supply.....	1
36	00-442611-00008	Bushing - Sleeve.....	1
37	00-444167	Collar - Hub Film Supply.....	1
38	00-913102-00174	Kit - Drive Collar & Film Grip (Incls. Items 39 & 40) (2 per shaft).....	1
39	00-446723	Grip - Film Roll.....	2
40	00-447758	Collar - Drive.....	4
41	00-444481	Washer - Spring.....	1
42	NS-015-20	Nut 1/2-13 Hex (SST).....	1
43	SC-059-29	Cap Screw 1/4-20 x 1/2 Hex Socket Hd. (SST).....	1
44	00-444156	End Cap - Idler Roller.....	1
45	00-444150	Bearing - Film Supply.....	1
46	00-444145	Roller - Idler.....	2
47	00-444149	Shaft - Idler Roller.....	2
48	00-444150	Bearing - Film Supply.....	2
49	00-444156	End Cap - Idler Roller.....	1
50	SC-059-29	Cap Screw 1/4-20 x 1/2 Hex Socket Hd. (SST).....	1
51	SC-122-29	Cap Screw 10-32 x 3/8 Socket Hex Hd.....	1
52	00-442308	Board Assy. - Film Sensor Interface.....	1
53	00-445505	Bracket - Film Sensor.....	1
54	SC-125-30	Mach. Screw 4-40 x 3/8 Phil. Pan Hd. (SST).....	1
55	WL-013-02	Lockwasher #4 Internal Shakeproof (SST).....	1
56	WS-031-61	Washer (SST).....	1
57	NS-011-01	Nut 4-40 Hex (SST).....	1

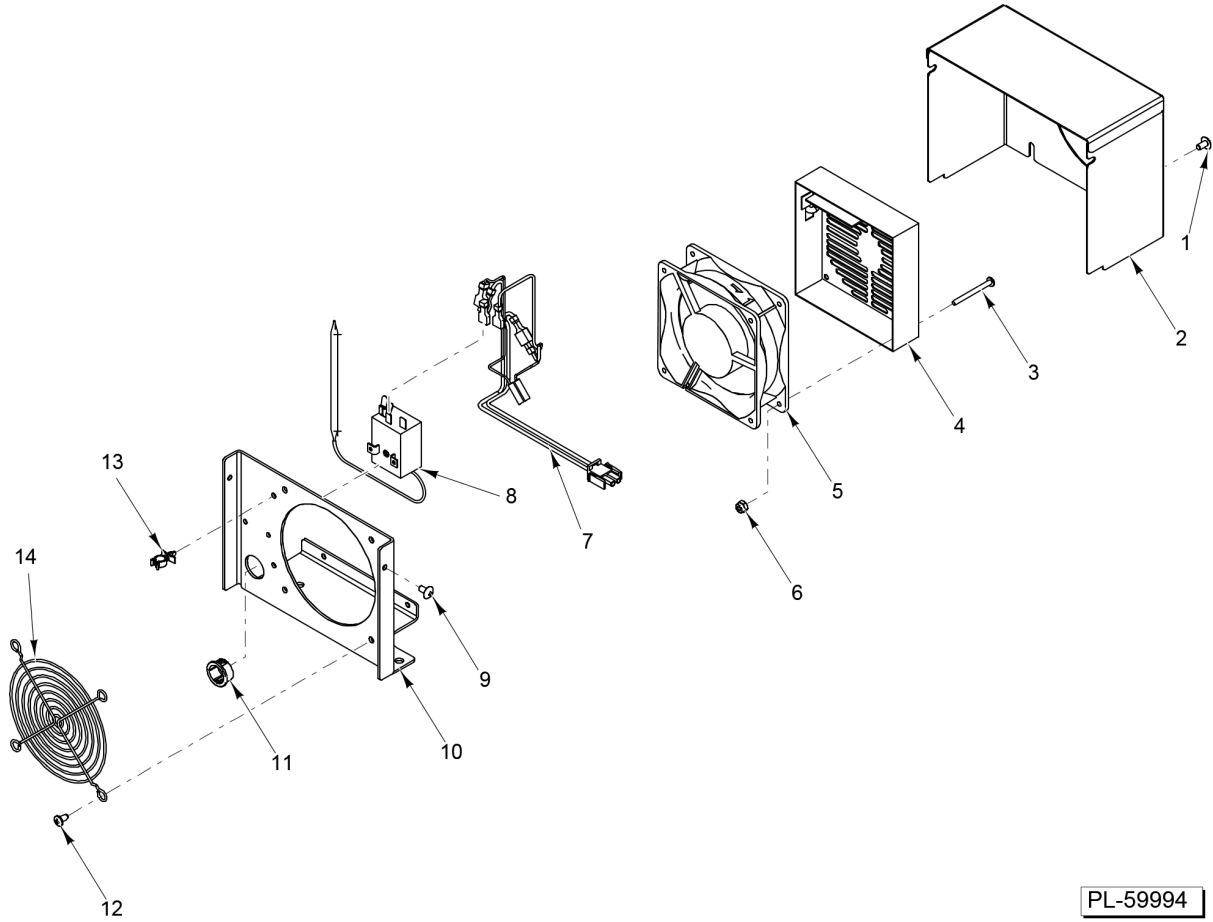

PL-59994

FILM HEATER

FILM HEATER

ILLUS.	PART NO.	NAME OF PART	AMT.
PL-59994			
1	SC-066-22	Mach. Screw 10-32 x 3/8 Phil. Truss Hd. (SST).....	2
2	00-444411	Cover - Heater.....	1
3	SC-018-67	NLA - Obsolete--Mach. Screw 8-32 x 1-3/4 Phil. Pan Hd.....	2
4	00-444413	Heater Assy.....	1
5	00-444412	Fan Assy. - Heater.....	1
6	NS-031-08	Stop Nut 8-32 Special (SST).....	2
7	00-443298	Cable Assy.....	1
8	00-442423	Thermostat - Bulb & Capillary.....	1
9	SC-066-22	Mach. Screw 10-32 x 3/8 Phil. Truss Hd. (SST).....	2
10	00-444410	Plate - Heater.....	1
11	FE-016-24	Bushing - Electrical Split.....	1
12	SD-024-38	Self-Tapping Screw 10-24 x 3/8 Phil. Pan Hd., Type TT.....	4
13	00-442454	Standoff - Wire Mounting.....	2
14	00-134014	Grill - Fan.....	1
	00-444409	Heater Assy. (Incls. Items 1 thru 14).....	1

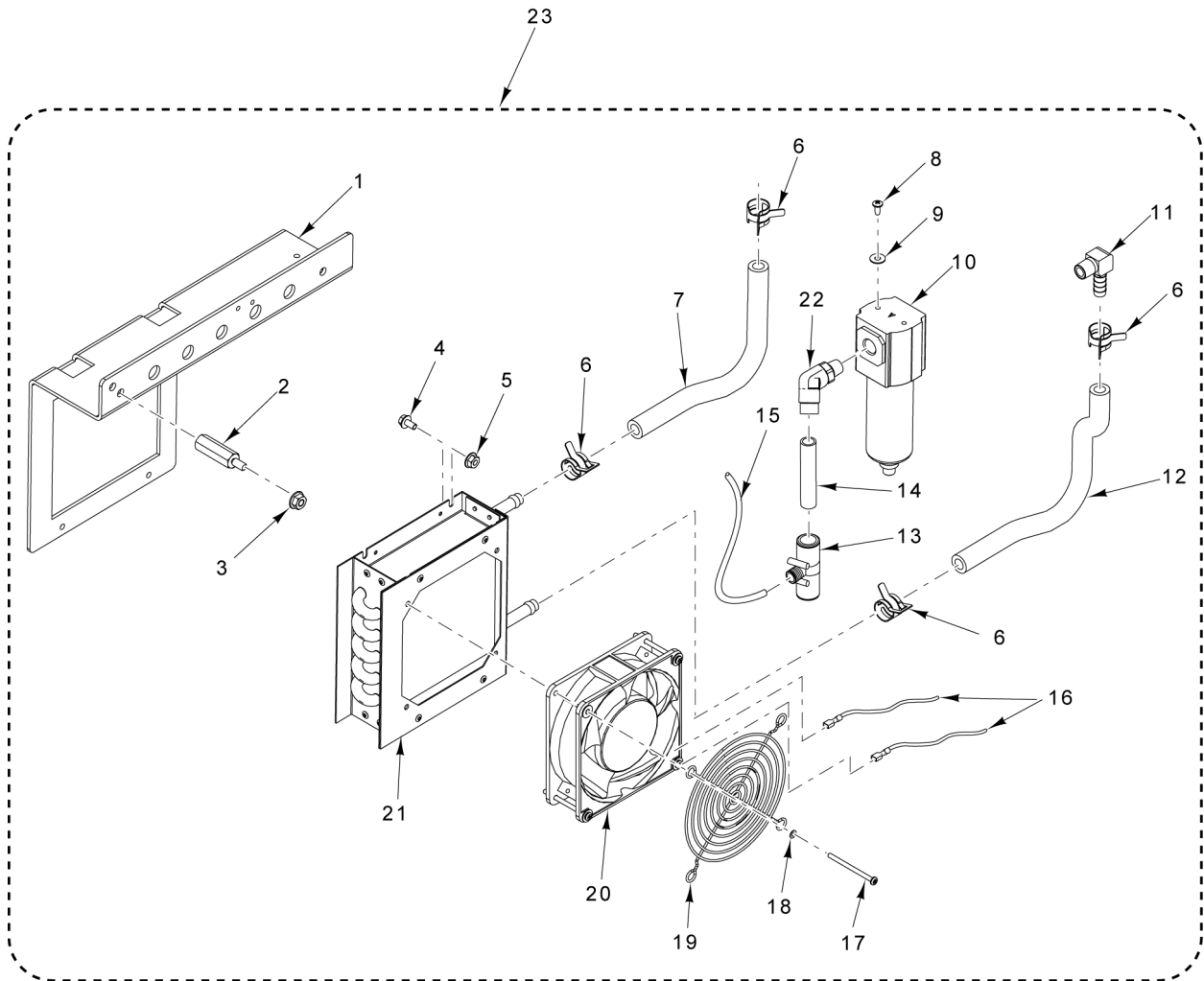

PL-60713

HEAT EXCHANGER

HEAT EXCHANGER

ILLUS.	PART NO.	NAME OF PART	AMT.
PL-60713			
1	00-447862	Bracket - Cooler.....	1
2	00-443851	Spacer - Motor.....	2
3	NS-049-06	Lock Nut 1/4-20 (SST).....	2
4	SC-100-04	Mach. Screw 10-24 x 3/8 Hex Washer Hd.....	4
5	NS-038-02	Lock Nut 10-24.....	4
6	00-446989	Clamp - Hose.....	AR
7	00-446996-00002	Hose 3/8 x 17 In. (Hi-Temp) (Silicone).....	1
8	SD-009-41	Self-Tapping Screw 8-32 x 3/8 Phil. Pan Hd., Type F (SST).....	2
9	WS-019-10	Washer (SST).....	2
10	00-444510	Filter - Dryer.....	1
11	00-446992	Fitting - Elbow 3/8 Tube.....	1
12	00-446996-00003	Hose 3/8 x 10 In. (Silicone).....	1
13	00-447918	Fitting 1/2 x 1/2 x 1/4 In.....	1
14	00-444491-00009	Tubing - 1/2 x 2.5 LG.....	1
15	00-444490-00025	Tubint - 1/4 x 9 In. (Polyurethane) (Blue).....	1
16	00-447630	Cable Assy.....	2
17	SC-123-91	Mach. Screw 6-32 x 2 Round Hd (SST).....	2
18	WL-008-02	Lockwasher #6 Internal Shakeproof.....	2
19	00-134014	Grill - Fan.....	1
20	00-447873	Fan (230 VAC).....	1
21	00-447861	Cooler Assy.....	1
22	00-448023	Fitting - Elbow 1/2 In.....	1
23	00-447930	Kit - Cooler Assy. (Incls. Items 1 thru 22).....	1

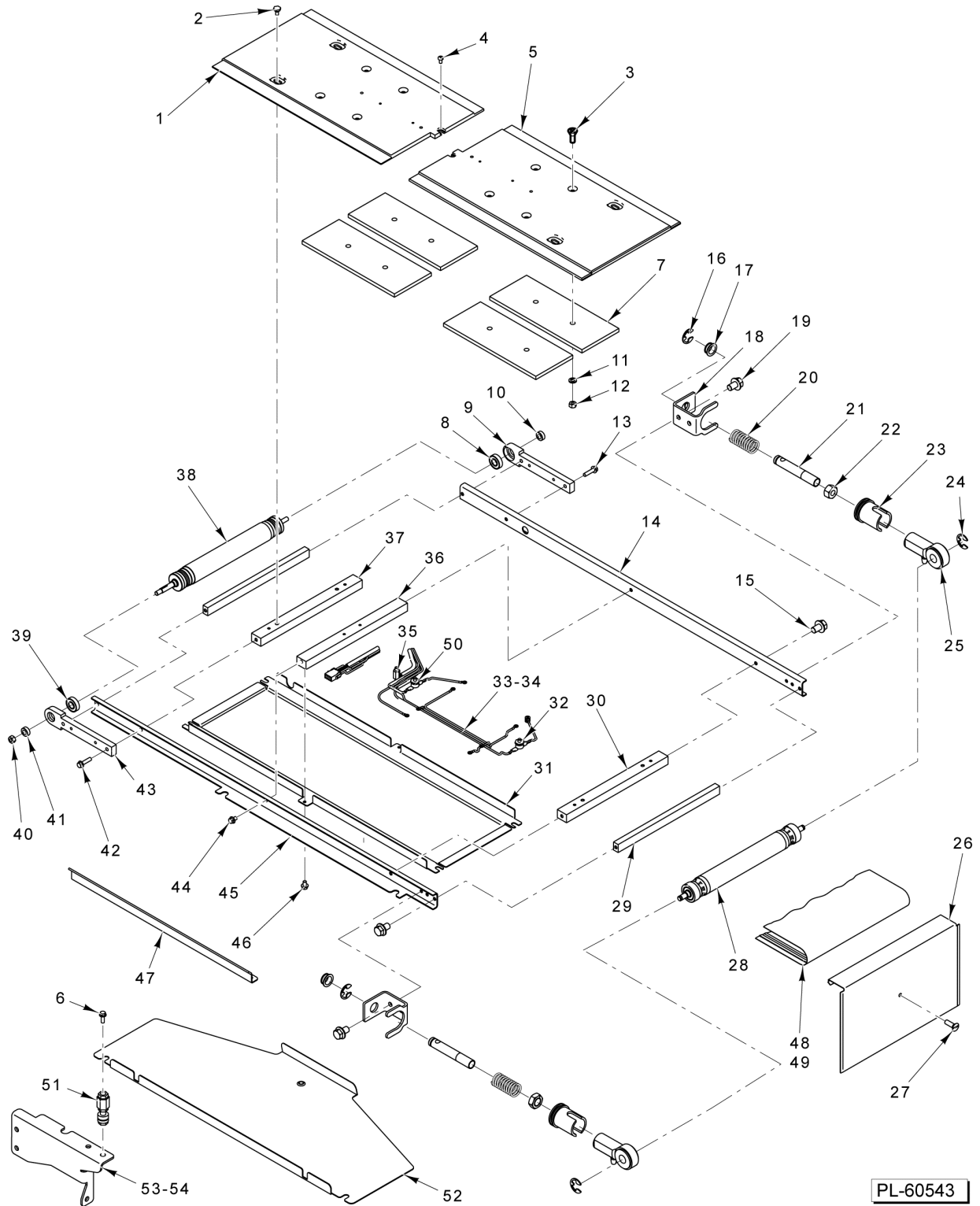

PL-60543

BELT SEALER

BELT SEALER

ILLUS. PL-60543	PART NO.	NAME OF PART	AMT.
1	00-444178	Plate - Hot.....	1
2	00-444177	Spacer.....	4
3	SC-029-47	Mach. Screw 5/16-18 x 1 Slotted Flat Hd. (Brass).....	8
4	SC-112-03	Mach. Screw 10-24 x 1/2 Pan Hd.....	2
5	00-444178	Plate - Hot.....	1
6	SC-129-49	Mach. Screw 1/4-20 x 1/2 Hex Washer Hd. (SST).....	2
7	00-444595	Element - Heater (500 W.).....	4
8	00-086780	Ball Bearing.....	1
9	00-444180	Block - Bearing.....	1
10	00-444182	Spacer - Bearing.....	1
11	WL-003-47	Lockwasher 5/16 Helical.....	8
12	NS-014-11	Nut 5/16-18 Hex (Brass).....	8
13	SC-123-93	Mach. Screw 1/4-20 x 1 Hex Washer Hd.....	2
14	00-444188	Rail Assy. (Left).....	1
15	SC-100-08	Mach. Screw 1/4-20 x 3/8 Hex Washer Hd.....	2
16	RR-009-10	Retaining Ring 3/8 In. (SST).....	2
17	00-041488	Bearing (Nyliner).....	2
18	00-444184	Bracket - Spring Retainer.....	2
19	SC-053-05	Mach. Screw 10-24 x 3/8 Slotted Truss Hd. (SST).....	4
20	00-444174	Spring - Sealer Belt.....	2
21	00-444186	Shaft - Sealer.....	2
22	NS-017-20	Jam Nut 3/8-24 Hex.....	2
23	00-444189	Bushing - Rod End Bearing.....	2
24	RR-009-10	Retaining Ring 3/8 In. (SST).....	2
25	00-334055	Rod - End (Female).....	2
26	00-444351	Cover - Sealer End.....	1
27	SC-053-41	Mach. Screw 1/4-20 x 1/2 Slotted Truss Hd. (SST).....	1
28	00-444194	Pulley Assy.....	1
29	00-444181	Bar - Cross.....	2
30	00-444173	Bar - Cross.....	1
31	00-444179	Pan - Sealer Belt.....	1
32	00-048514	Sensor - Thermal Hi-Limit.....	1
33	00-443349	Cable Assy. - Sealer Belt Harness.....	1
34	00-443301	Cable Assy. - Sealer Belt.....	1
35	00-443350	Probe Assy. - Thermistor.....	1
36	00-444183	Bar - Cross.....	1
37	00-444173	Bar - Cross.....	1
38	00-447267	Pulley Assy.....	1
39	00-086780	Ball Bearing.....	1
40	NS-015-11	Nut 5/16-18 Hex (SST).....	2
41	00-444182	Spacer - Bearing.....	1
42	SC-123-93	Mach. Screw 1/4-20 x 1 Hex Washer Hd.....	2
43	00-444180	Block - Bearing.....	1
44	SC-100-08	Mach. Screw 1/4-20 x 3/8 Hex Washer Hd.....	2
45	00-444187	Rail Assy. (Right).....	1
46	SC-100-08	Mach. Screw 1/4-20 x 3/8 Hex Washer Hd.....	2
47	00-444575	Support - Operator Cover.....	1
48	00-444849	Belt - Sealer (Durasil) (Incls. Item 49).....	1
49	00-445023	Pin - Sealer Belt.....	1
50	00-048514	Sensor - Thermal Hi-Limit.....	1
51	00-446708	Support Assy. - Sealer Belt.....	2
52	00-446211	Cover - Belt.....	1
53	00-445342	Bracket - Sealer (RH).....	1
54	00-445343	Bracket - Sealer (LH).....	1

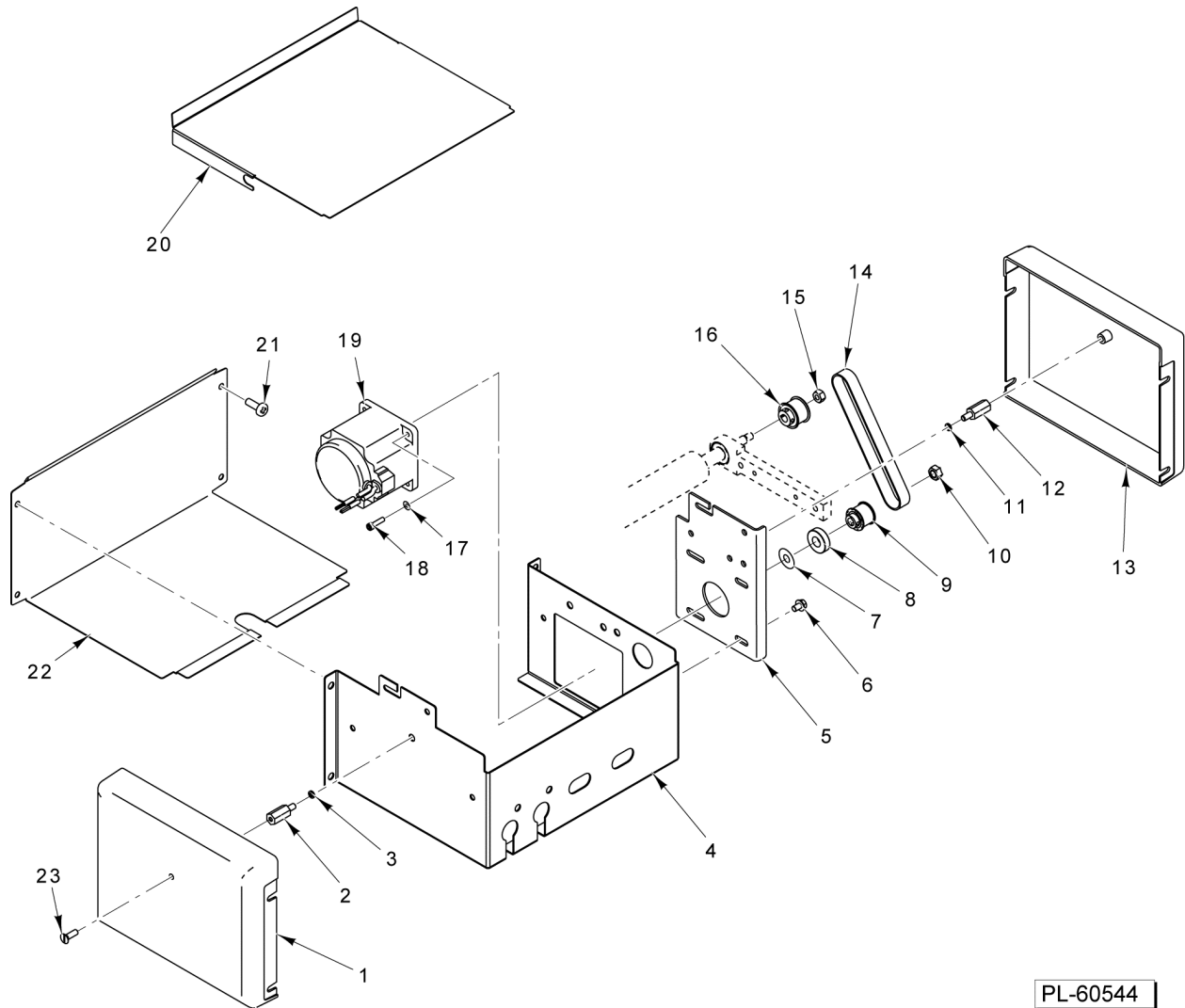

PL-60544

BELT SEALER MOTOR

BELT SEALER MOTOR

ILLUS.	PART NO.	NAME OF PART	AMT.
PL-60544			
1	00-444335	Cover - Belt Sealer Motor.....	1
2	00-444449	Standoff - Sealer Cover.....	1
3	WL-006-07	Lockwasher #10 Helical (SST).....	1
4	00-447296	Cover - Motor.....	1
5	00-447292	Bracket - Motor.....	1
6	SC-100-08	Mach. Screw 1/4-20 x 3/8 Hex Washer Hd.....	4
7	WS-018-31	Washer (SST).....	1
8	00-444077	Bearing - Sealed.....	1
9	00-443860	Pulley (16T).....	1
10	NS-038-10	Lock Nut 3/8-16 Hex.....	1
11	WL-006-07	Lockwasher #10 Helical (SST).....	1
12	00-444449	Standoff - Sealer Cover.....	1
13	00-444335	Cover - Belt Sealer Motor.....	1
14	00-446218	Belt - Sealer (360mm).....	1
15	NS-015-11	Nut 5/16-18 Hex (SST).....	1
16	00-443862	Pulley (18T).....	1
17	WL-006-06	Lockwasher #10 Helical (SST).....	4
18	SC-123-01	Cap Screw 10-24 x 3/4 Hex Socket Hd. (SST).....	4
19	00-447659	Motor (10-Pole).....	1
20	00-446766	Shield - Sealer Motor.....	1
21	SC-053-41	Mach. Screw 1/4-20 x 1/2 Slotted Truss Hd. (SST).....	4
22	00-446273	Cover - Sealer Belt.....	1
23	SC-093-27	Mach. Screw 10-24 x 7/8 Phil. Truss Hd. (SST).....	1

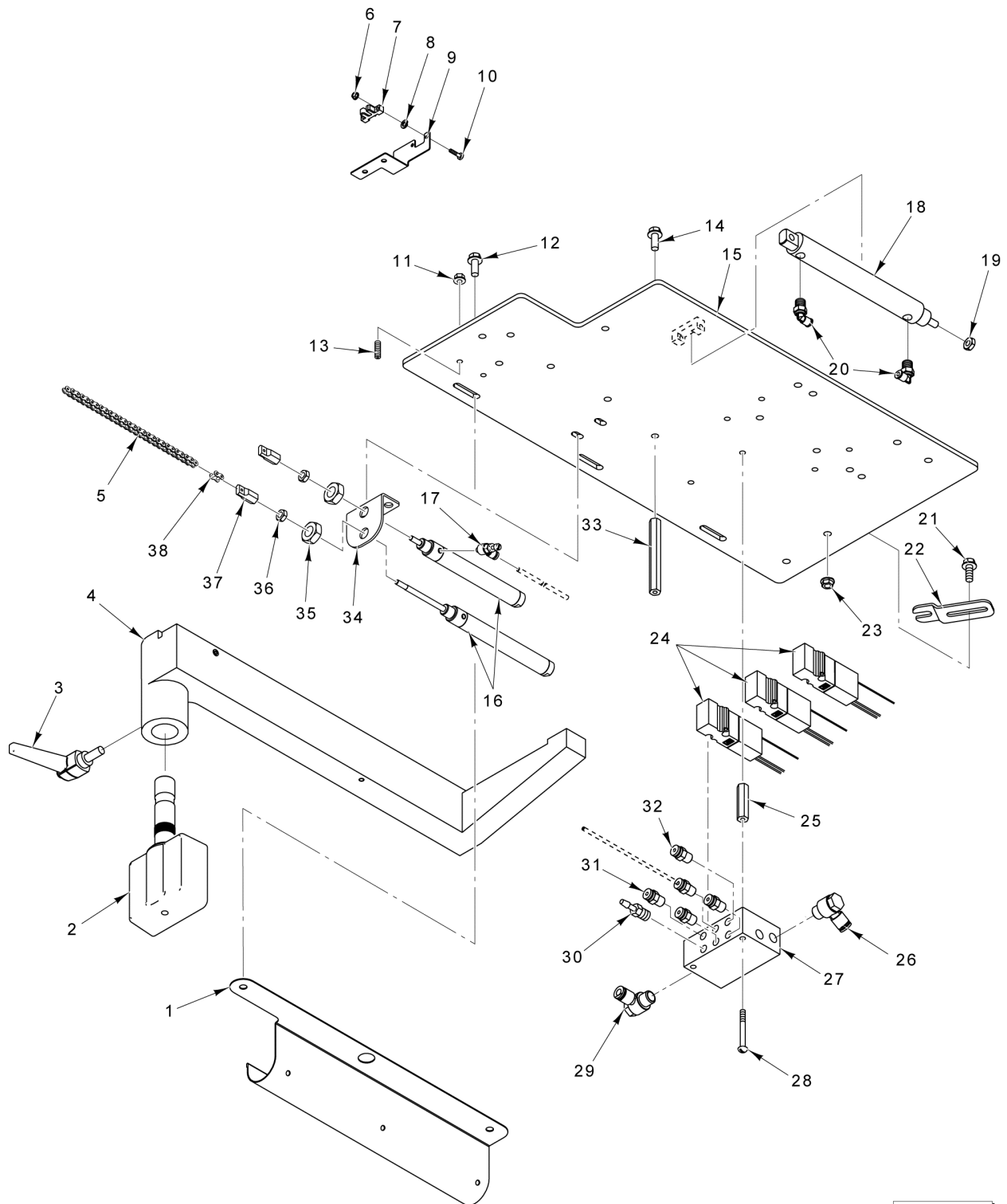

PL-60545

LABEL APPLIER

LABEL APPLIER

ILLUS.	PART NO.	NAME OF PART	AMT.
PL-60545			
1	00-444460	Tray - Cable Support.....	1
2	00-444326	Support Assy. - Pivot Display.....	2
3	00-442734	Knob - Console Mount.....	1
4	00-444319	Support Assy. - Printer.....	1
5	00-444123	Chain #25 Single Strand.....	1
6	NS-009-02	Nut 4-40 Hex.....	2
7	00-443326	Sensor Assy. Applier Home.....	1
8	WL-003-03	Lockwasher #4 Helical.....	2
9	00-443031	Bracket - Sensor.....	1
10	SC-113-10	Mach. Screw 4-40 x 3/8 Phil. Pan Hd.....	2
11	NS-049-06	Lock Nut 1/4-20 (SST).....	2
12	SC-123-92	Mach. Screw 1/4-20 x 5/8 Hex Washer Hd.....	3
13	SC-049-03	Set Screw 1/4-20 x 1-1/4 Slotted Hdls., Oval Pt. (SST).....	2
14	SC-100-04	Mach. Screw 10-24 x 3/8 Hex Washer Hd.....	2
15	00-443001	Plate - Printer Support.....	1
16	00-446028	Cylinder - Wand 9/16 x 2 In. Stroke.....	2
17	00-444113	Fitting - Flow Control Tube.....	2
18	00-446029	Cylinder - Applier 0.75 x 3.5 In. Stroke.....	1
19	NS-017-60	Jam Nut 1/4-28 Hex.....	1
20	00-444121	Fitting - Elbow.....	2
21	SC-123-92	Mach. Screw 1/4-20 x 5/8 Hex Washer Hd.....	14
22	00-442995	Retainer - Foot.....	3
23	NS-049-06	Lock Nut 1/4-20 (SST).....	12
24	00-447301	Valve (Humphrey).....	1
25	00-445158	Standoff.....	2
26	00-444052	Fitting - Tube (Banjo Elbow).....	1
27	00-446798	Manifold - Valve (Humphrey).....	1
28	SC-098-06	Mach. Screw 10-24 x 1-3/4 Slotted Rd. Hd. (SST).....	2
29	00-444052	Fitting - Tube (Banjo Elbow).....	1
30	00-041720	Silencer - Valve.....	1
31	00-444464	Fitting - Tube (Straight Male).....	1
32	00-443017	Fitting - Tube Male Connector.....	4
33	00-445159	Standoff.....	2
34	00-443008	Bracket - Cylinder Mounting.....	1
35	NS-046-30	Jam Nut 7/16-20 Hex (SST).....	2
36	NS-009-30	Nut 10-32 Hex.....	2
37	00-443010	Connector - Cylinder.....	2
38	00-444124	Chain - Connecting Link #25.....	2

LABEL APPLIER ARM WITH MOTOR

ILLUS. PL-59998	PART NO.	NAME OF PART	AMT.
1	00-041638	Belt - Printer.....	1
2	00-443029	Pulley (20T).....	1
3	NS-038-02	Lock Nut 10-24.....	4
4	00-443011	Bracket - Motor.....	1
5	00-443368	Motor Assy.-Stepper L.A.....	1
6	SC-121-77	Mach. Screw 10-24 x 5/8 Phil. Pan Hd.....	4
7	00-443006	Pivot Assy. - Applier Pad (Incls. Item 26).....	1
8	00-443002	Pivot - Applier.....	1
9	00-041850	Pin - Upper Pivot.....	1
10	00-175560	Bushing - Nyliner.....	2
11	RR-006-22	Retaining Ring 1/4 In. (SST).....	1
12	00-446314	Link - Applier.....	1
13	00-175560	Bushing - Nyliner.....	2
14	RR-006-22	Retaining Ring 1/4 In. (SST).....	1
15	00-041845	Support - Slide.....	1
16	NS-049-06	Lock Nut 1/4-20 (SST).....	1
17	SC-081-44	Mach. Screw 10-32 x 1-1/2 Slotted Rd. Hd.....	1
18	00-041853	Spacer - Arm Pivot.....	1
19	00-041850	Pin - Upper Pivot.....	1
20	00-447235	Spring - Applier.....	1
21	00-444525	Spacer - Torsion Spring.....	1
22	RR-011-04	Retaining Ring.....	1
23	00-042120	Spring - Applier.....	1
24	SD-007-13	Self-Tapping Screw 6-20 x 1/4 Phil. Pan Hd., Type B.....	2
25	00-444048	Plate - Nut.....	1
26	00-042114	Pin - Applier.....	1
27	00-042076	Block - Pin.....	1
28	00-443036	Support - Applier Pad.....	1
29	00-443035	Spring - Torsion.....	1
30	00-443007	Pin - Applier.....	1
31	00-043253	Bushing - Nyliner.....	1
32	RR-011-04	Retaining Ring.....	1
33	SC-015-08	Mach. Screw 6-32 x 1/4 Slotted Oval Hd.....	4
34	00-443966	Applier - Label.....	1
35	SD-007-13	Self-Tapping Screw 6-20 x 1/4 Phil. Pan Hd., Type B.....	1
36	00-042073	Arm - Label Applier.....	1
37	NS-009-30	Nut 10-32 Hex.....	1
38	WL-007-12	Lockwasher #10 External Shakeproof.....	1
39	00-443004	Block - Slide.....	1
	00-443033	Pad - Arm Applier Assy. (Incls. Items 25, 28, 33, & 34).....	1
	00-443300	External Cable (Stepper Motor/Sensor).....	1

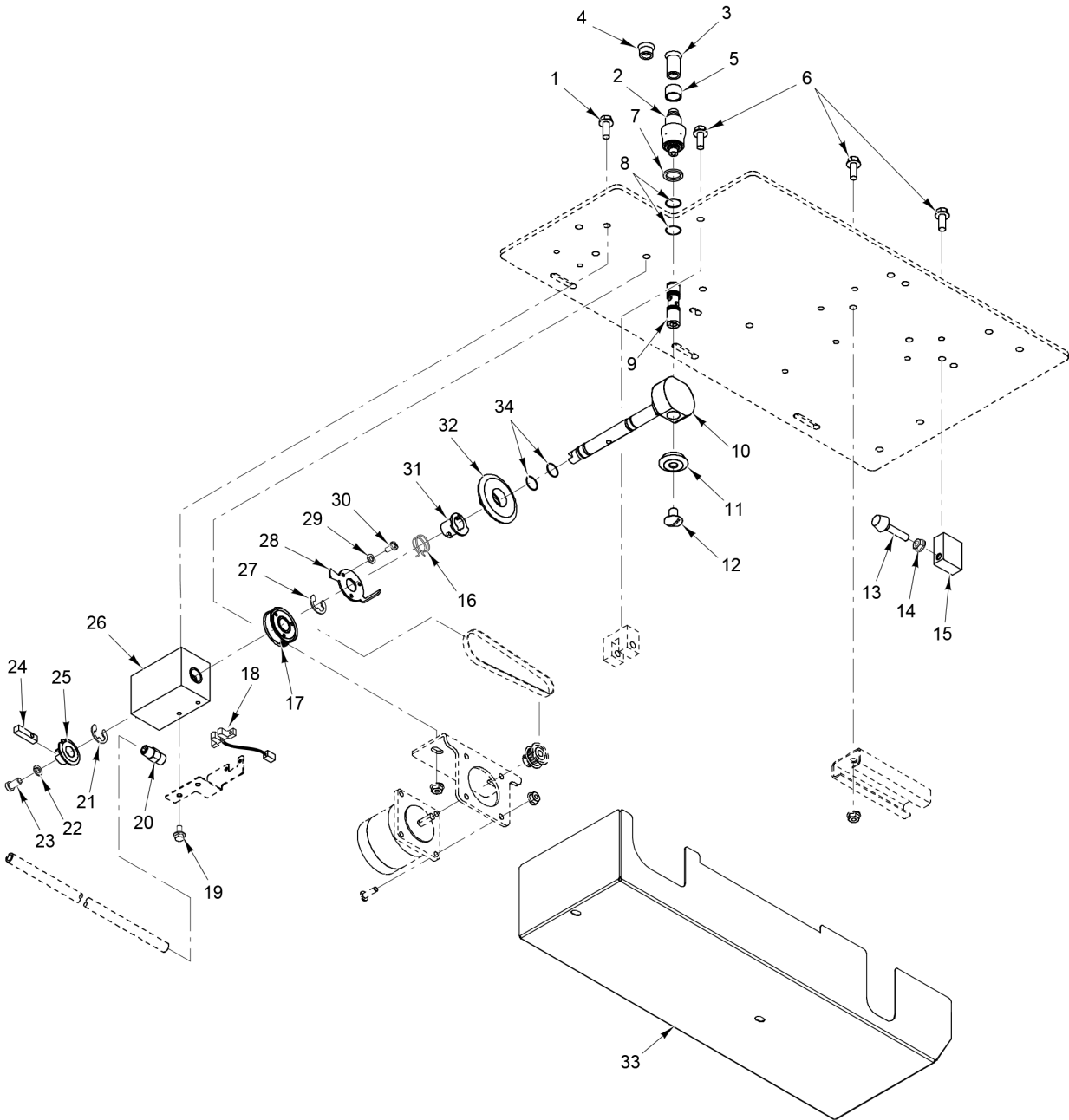

PL-59999

**LABEL APPLIER
(WAND AND BLOCK)**

**LABEL APPLIER
(WAND AND BLOCK)**

ILLUS.	PART NO.	NAME OF PART	AMT.
	PL-59999		
1	SC-123-92	Mach. Screw 1/4-20 x 5/8 Hex Washer Hd.....	AR
2	00-446525	Wand Assy. - Pop Up (Incls. Items 3, 4, 5, & 7).....	1
3	00-443494	Cup - Short Wand.....	1
4	00-441537	Wand Tip - Flared.....	AR
5	00-443583	Sleeve - Bearing.....	1
6	SC-123-92	Mach. Screw 1/4-20 x 5/8 Hex Washer Hd.....	AR
7	00-441526	Seal - Rear Housing.....	1
8	00-441580-00002	O-Ring.....	2
9	00-441496	Tube - Swing Assy.....	1
10	00-443041	Wand Shaft & Bearing Assy.....	1
11	00-041681	Pinion.....	1
12	SC-053-15	Mach. Screw 5/16-18 x 1/2 Slotted Truss Hd. (SST).....	1
13	00-443742	Bumper.....	1
14	NS-038-02	Lock Nut 10-24.....	1
15	00-443896	Block - Cylinder Stop.....	1
16	00-443028	Spring - Torsion.....	1
17	00-443040	Pulley Assy.- Wand.....	1
18	00-443326	Sensor Assy. Applier Home.....	1
19	SC-100-04	Mach. Screw 10-24 x 3/8 Hex Washer Hd.....	3
20	00-443016	Fitting - Connector Tube.....	1
21	RR-010-12	Retaining Ring.....	1
22	WL-003-09	Lockwasher #6 Helical.....	1
23	SC-092-36	Cap Screw 6-32 x 1/2 Hex Socket Hd.....	1
24	00-443021	Key - 1/4 Sq. x 1 In. Lg.....	1
25	00-443020	Sprocket - 12 Tooth #25.....	1
26	00-443038	Pivot - Block Assy.....	1
27	RR-010-12	Retaining Ring.....	1
28	00-443026	Plate - Pulley Stop.....	1
29	WL-003-09	Lockwasher #6 Helical.....	3
30	SC-018-28	Mach. Screw 6-32 x 1/4 Phil. Pan Hd.....	3
31	00-443027	Sleeve-Spring.....	1
32	00-041680	Gear.....	1
33	00-446355	Cover - Applier.....	1
34	00-441580-00002	O-Ring.....	2

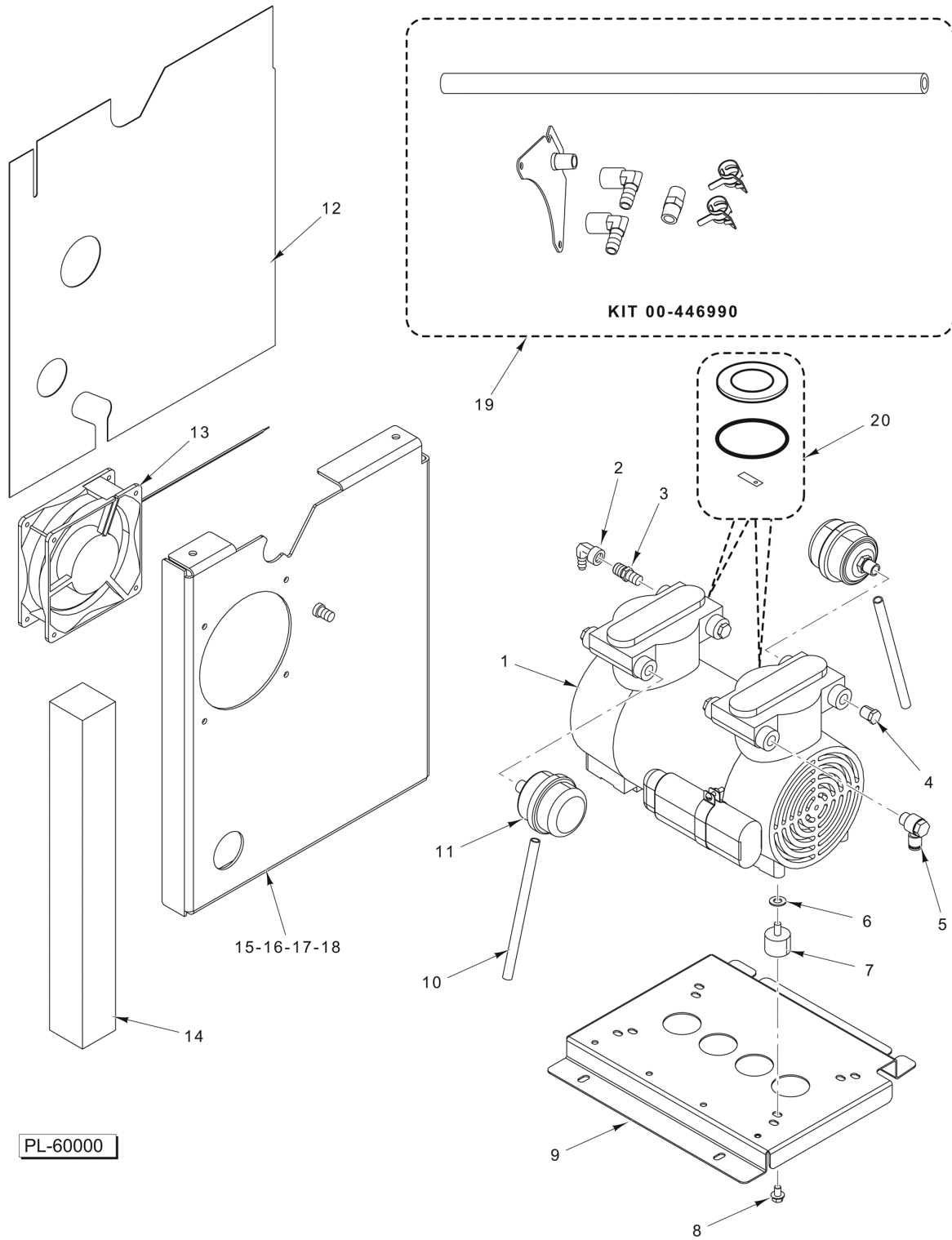

COMPRESSOR ASSEMBLY (GAST)

COMPRESSOR ASSEMBLY (GAST)

ILLUS. PL-60000	PART NO.	NAME OF PART	AMT.
1	00-447240	Compressor Assy. (Gast) (Incls. Items 2 thru 11).....	1
2	00-446992	Fitting - Elbow 3/8 Tube.....	1
3	00-446995	Fitting - Pipe 1/4.....	1
4	FP-090-76	Pipe Plug 1/4 Hex Hd.....	4
5	00-444052	Fitting - Tube (Banjo Elbow).....	1
6	WS-022-04	Washer (SST).....	4
7	00-444038	Mount - Hinge.....	4
8	SC-100-08	Mach. Screw 1/4-20 x 3/8 Hex Washer Hd.....	4
9	00-443993	Plate - Compressor Mounting.....	1
10	00-446424	Tube - Muffler.....	2
11	00-446290	Muffler - Compressor (Gast).....	2
12	00-446328	Baffle - Airflow.....	1
13	00-444496	Fan Assy. - Heater.....	1
14	00-446382	Seal - Foam.....	1
15	00-446997	Support Assy.....	1
16	SD-024-18	Self-Tapping Screw 10-24 x 1/2 Hex Hd., Type TT.....	4
17	SC-123-92	Mach. Screw 1/4-20 x 5/8 Hex Washer Hd.....	4
18	NS-038-08	Lock Nut 1/4-20 x 1 Hex.....	4
19	00-446990	Kit - Compressor Hose.....	1
20	00-447236	Kit - Compressor Repair.....	1

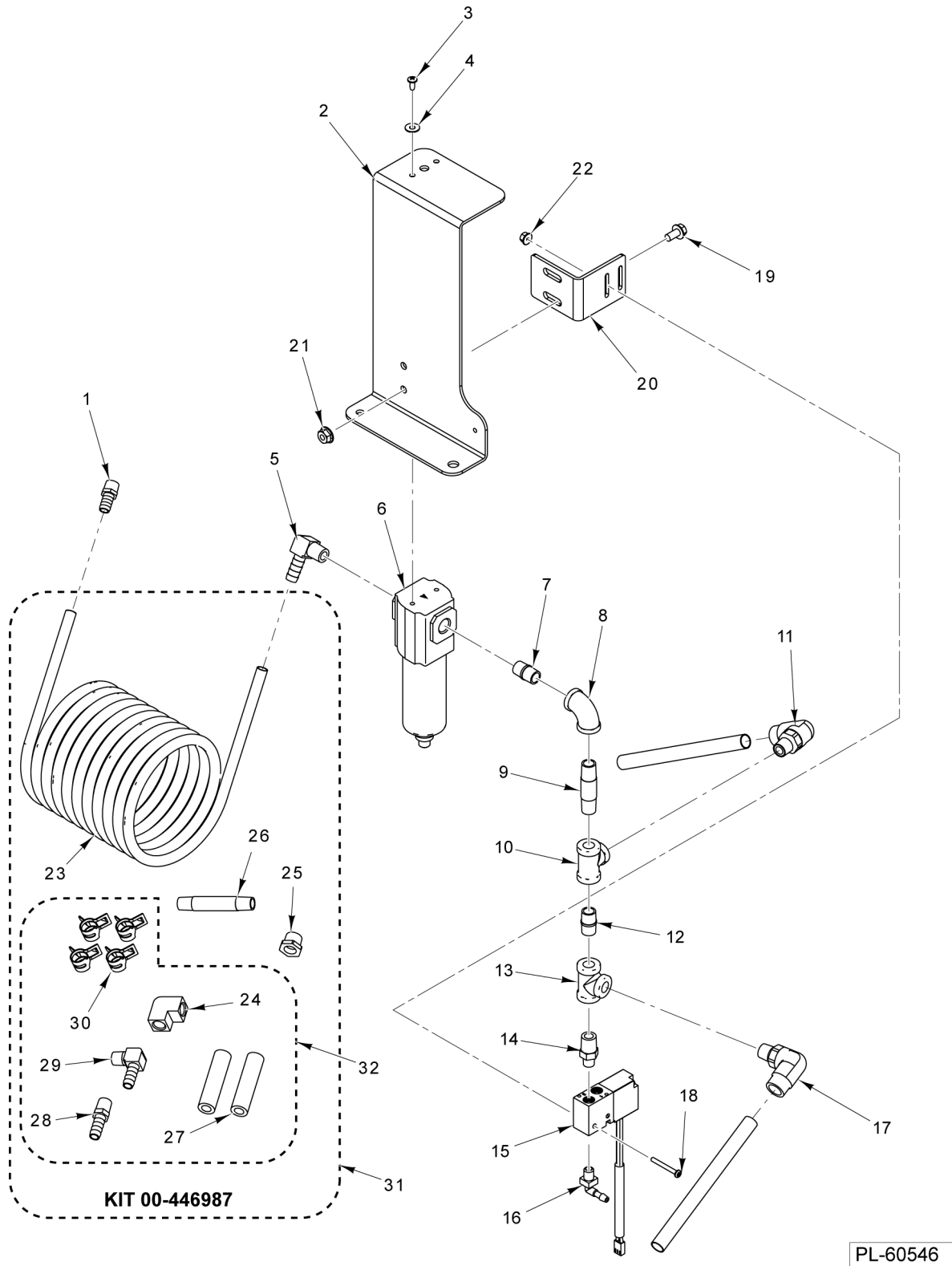

AIR DRYER FILTER ASSEMBLY

AIR DRYER FILTER ASSEMBLY

ILLUS. PL-60546	PART NO.	NAME OF PART	AMT.
1	00-446994	Fitting 3/8 Tube Straight.....	1
2	00-446298	Bracket - Filter Dryer.....	1
3	SD-009-41	Self-Tapping Screw 8-32 x 3/8 Phil. Pan Hd., Type F (SST).....	2
4	WS-019-10	Washer (SST).....	2
5	00-446991	Fitting - Elbow 3/8 Tube.....	1
6	00-444510	Filter - Dryer.....	1
7	FP-040-08	Pipe 1/4 x 7/8 TBE (Brass).....	1
8	FP-015-05	Elbow - Pipe 1/4 x 90 Deg. (Brass).....	1
9	FP-040-14	Pipe 1/4 x 2 TBE (Brass).....	1
10	FP-019-08	Tee - Pipe (Brass).....	1
11	00-444473	Elbow - Swivel Male.....	1
12	FP-040-08	Pipe 1/4 x 7/8 TBE (Brass).....	1
13	FP-019-08	Tee - Pipe (Brass).....	1
14	00-447298	Pipe 1/8 x 1/4.....	1
15	00-447299	Valve (120 In. Lead) (Humphrey).....	1
16	00-041719	Fitting - Elbow.....	1
17	00-444473	Elbow - Swivel Male.....	1
18	SC-131-76	Mach. Screw 6-32 x 1-1/4 Phil. Pan Hd.....	2
19	SC-129-49	Mach. Screw 1/4-20 x 1/2 Hex Washer Hd. (SST).....	1
20	00-447304	Bracket - Valve.....	1
21	NS-038-04	Lock Nut 1/4-20.....	1
22	NS-038-01	Lock Nut 6-32 Flange.....	2
23	00-446986	Coil - Cooling.....	1
24	00-446993	Fitting - Elbow 1/4.....	1
25	FP-027-42	Bushing - Pipe 3/8 to 1/4 (Brass).....	1
26	FP-075-70	Pipe 1/4 x 3 TBE (Brass).....	1
27	00-446996-00001	Tubing 3/8.....	2
28	00-446994	Fitting 3/8 Tube Straight.....	1
29	00-446991	Fitting - Elbow 3/8 Tube.....	1
30	00-446989	Clamp - Hose.....	4
31	00-446987	Kit - Cooling Coil Replacement (Incls. Items 23 thru 30).....	1
32	00-447279	Kit - Cooling Coil Mounting (Incls. Items 24 & 27 thru 30).....	1

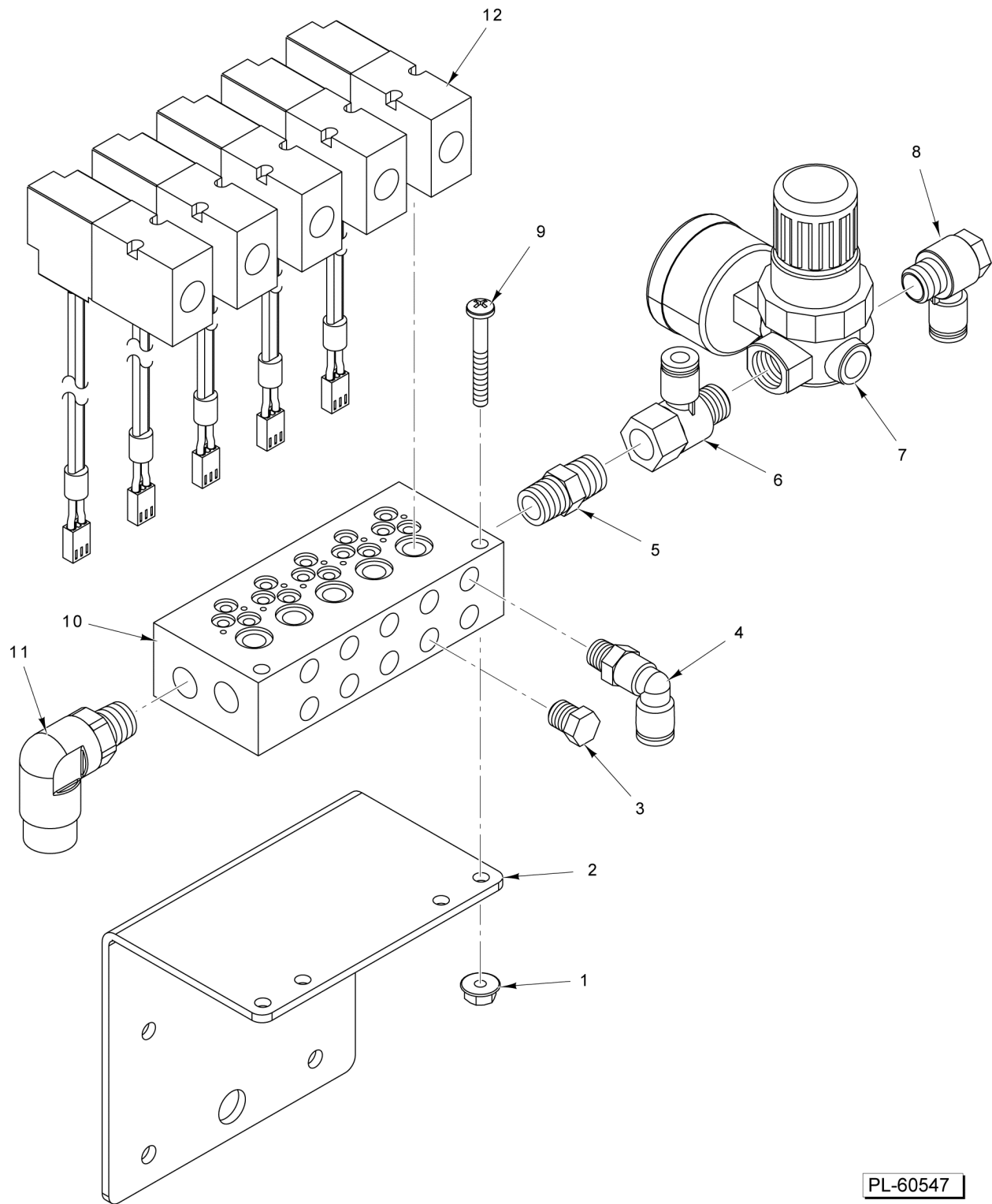

PL-60547

AIR MANIFOLD ASSEMBLY

AIR MANIFOLD ASSEMBLY

ILLUS.	PART NO.	NAME OF PART	AMT.
PL-60547			
1	NS-038-02	Lock Nut 10-24.....	2
2	00-447737	Bracket - Manifold Mounting.....	1
3	00-042779	Plug.....	5
4	00-444467	Fitting - Swivel 90 Deg. Elbow Tube.....	5
5	00-446995	Fitting - Pipe 1/4.....	1
6	00-447739	Tee - Fitting.....	1
7	00-444474	Regulator - Pressure (Incls. Gauge).....	1
8	00-444052	Fitting - Tube (Banjo Elbow).....	1
9	SC-111-29	NLA - Obsolete--Mach. Screw 10-24 x 1-1/2 Phil. Pan Hd.....	2
10	00-447446	Manifold.....	1
11	00-444473	Elbow - Swivel Male.....	1
12	00-447697	Valve Assy.....	5

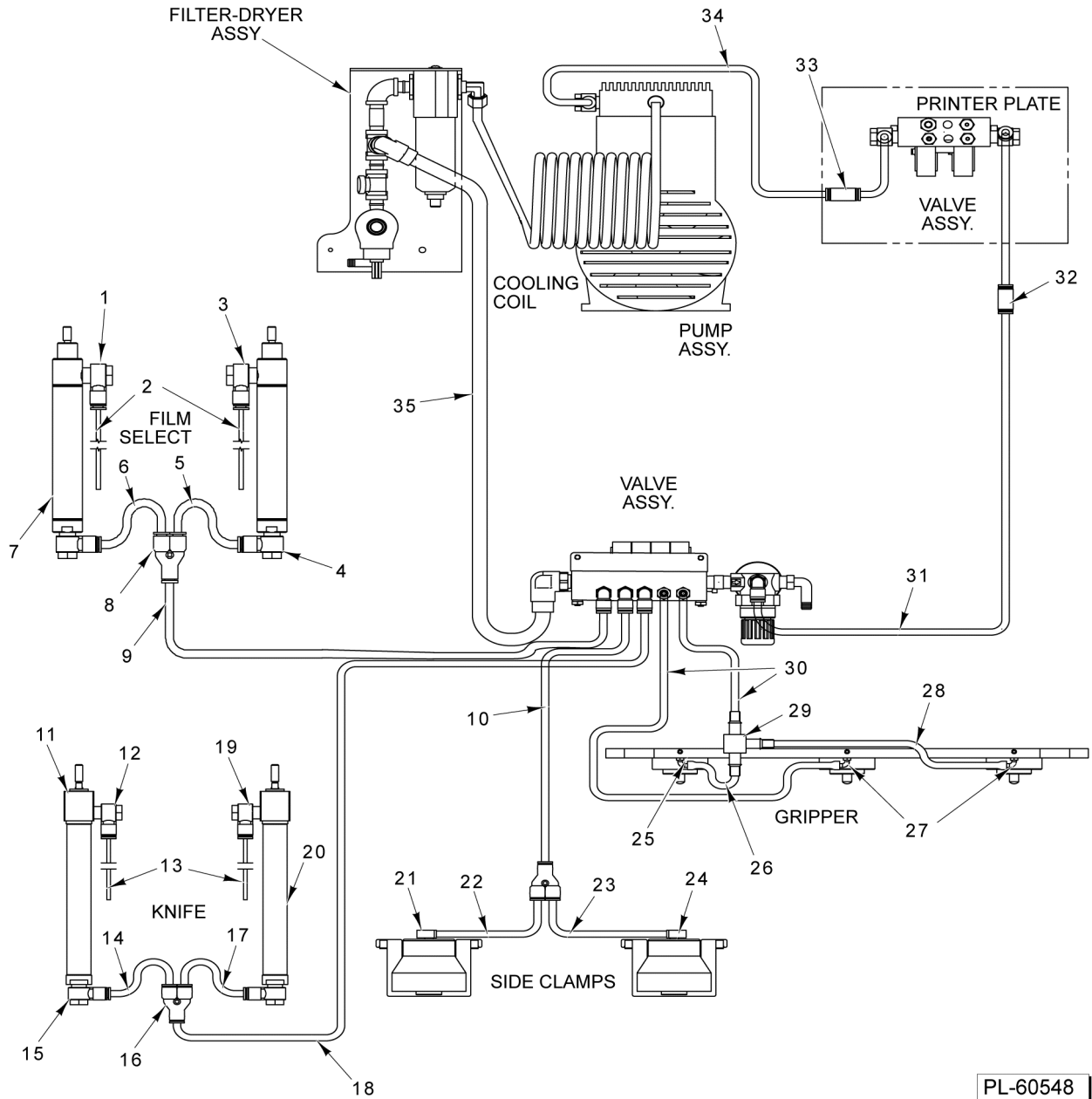

PL-60548

HOSE DIAGRAM (MAIN)

HOSE DIAGRAM (MAIN)

ILLUS. PL-60548	PART NO.	NAME OF PART	AMT.
1	00-444121	Fitting - Elbow.....	1
2	00-444489-00002	Tubing - Natural Polyurethane (1/8).....	2
3	00-444121	Fitting - Elbow.....	1
4	00-444467	Fitting - Swivel 90 Deg. Elbow Tube.....	2
5	00-444490-00004	Tubing - Blue Polyurethane (1/4).....	1
6	00-444490-00004	Tubing - Blue Polyurethane (1/4).....	1
7	00-446597	Cylinder - Film Changer.....	2
8	00-444466	Fitting - Union Tube (Y).....	1
9	00-444490-00013	Tubing - Blue Polyurethane (1/4).....	1
10	00-444490-00010	Tubing - Yellow Polyurethane (1/4).....	1
11	00-447513	Cylinder - Air.....	1
12	00-444121	Fitting - Elbow.....	1
13	00-444489-00002	Tubing - Natural Polyurethane (1/8).....	2
14	00-444490-00006	Tubing - Natural Polyurethane (1/4).....	1
15	00-444467	Fitting - Swivel 90 Deg. Elbow Tube.....	2
16	00-444466	Fitting - Union Tube (Y).....	1
17	00-444490-00006	Tubing - Natural Polyurethane (1/4).....	1
18	00-444490-00019	Tubing - Natural Polyurethane (1/4).....	1
19	00-444121	Fitting - Elbow.....	1
20	00-447513	Cylinder - Air.....	1
21	00-444652	Fitting - Elbow 10-32 Adjustable.....	2
22	00-444490-00008	Tubing - Yellow Polyurethane (1/4).....	1
23	00-444466	Fitting - Union Tube (Y).....	1
24	00-444490-00008	Tubing - Yellow Polyurethane (1/4).....	1
25	00-443913	Fitting - Elbow.....	1
26	00-444493-00005	Tubing - Polyurethane (1/4).....	1
27	00-443913	Fitting - Elbow.....	2
28	00-444493-00004	Tubing - Polyurethane (1/4).....	1
29	00-444640	Fitting - Hose Tee (1/8).....	1
30	00-445055	Tubing - Natural & Black Gripper (1/4).....	2
31	00-444490-00011	Tubing - Red Polyurethane (1/4).....	1
32	00-444624	Connector - Straight (1/4).....	1
33	00-444624	Connector - Straight (1/4).....	1
34	00-444490-00012	Tubing - Blue Polyurethane (1/4).....	1
35	00-444491-00004	Tubing - Natural Nylon (1/2).....	1

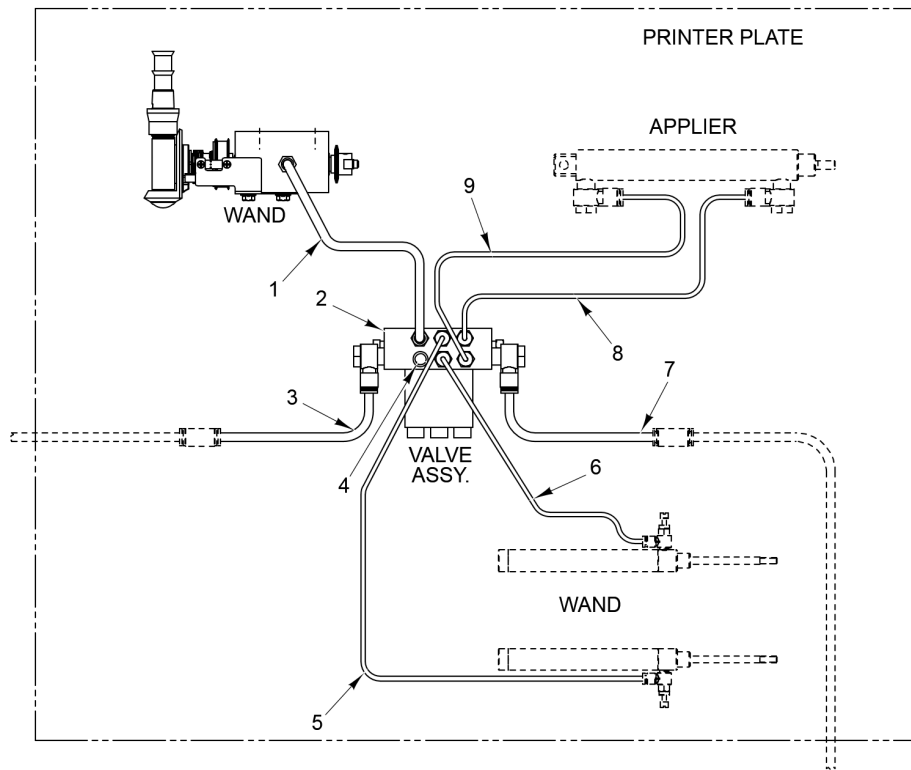

PL-60004

**HOSE DIAGRAM
(PRINTER PLATE)**

**HOSE DIAGRAM
(PRINTER PLATE)**

ILLUS.	PART NO.	NAME OF PART	AMT.
PL-60004			
1	00-444490-00001	Tubing - Black Polyurethane (1/4).....	1
2	00-446798	Manifold - Valve.....	1
3	00-444490-00013	Tubing - Blue Polyurethane (1/4).....	1
4	00-041720	Silencer - Valve.....	1
5	00-444489-00001	Tubing - Natural Polyurethane (1/8).....	1
6	00-444489-00001	Tubing - Natural Polyurethane (1/8).....	1
7	00-444490-00009	Tubing - Red Polyurethane (1/4).....	1
8	00-444489-00002	Tubing - Natural Polyurethane (1/8).....	1
9	00-444489-00002	Tubing - Natural Polyurethane (1/8).....	1
	00-445761	Cable Assy. (LA Valve) (Use With Item 2).....	1

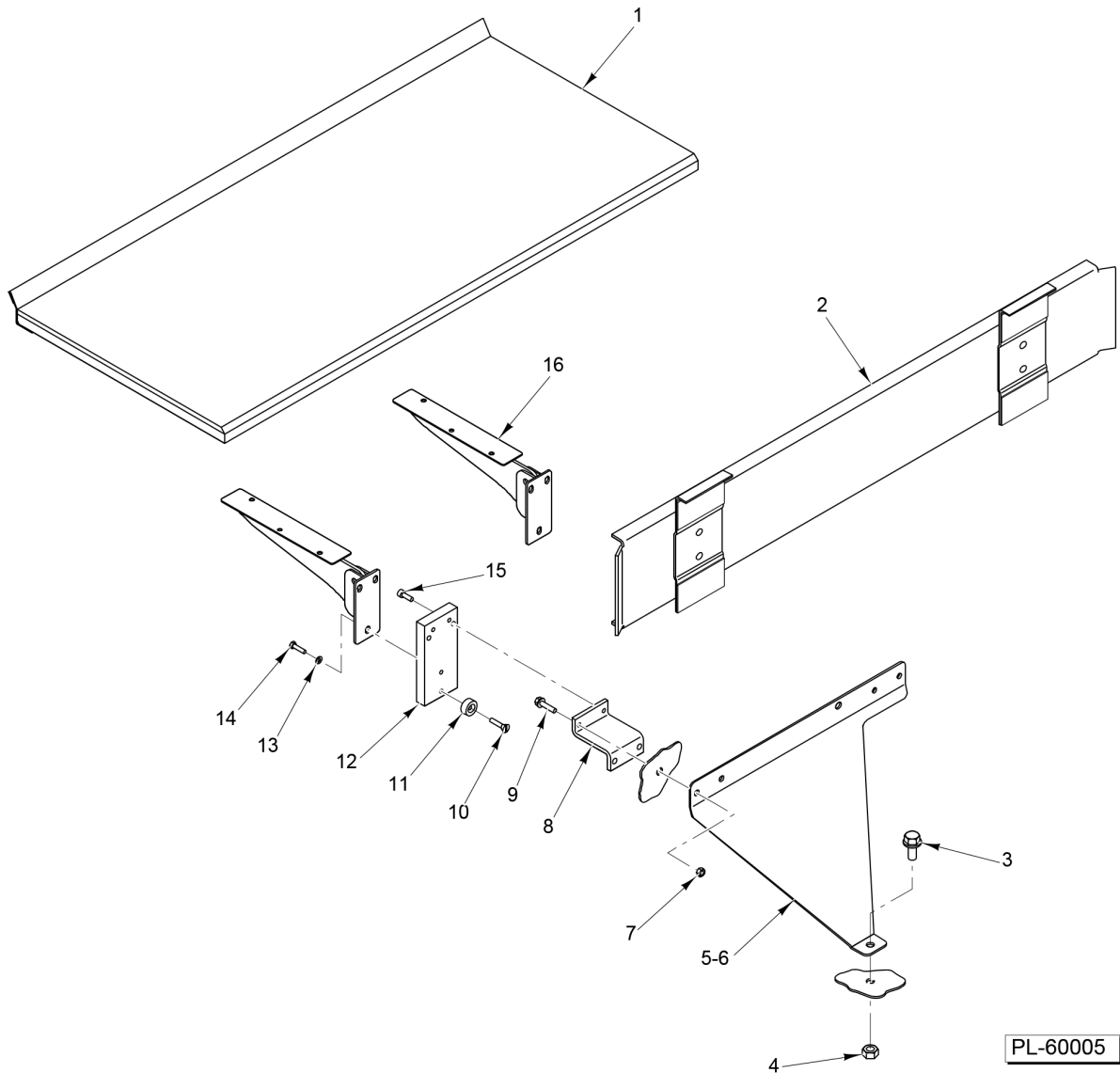

AWS SHELF

AWS SHELF

ILLUS.	PART NO.	NAME OF PART	AMT.
PL-60005			
1	00-440960	Shelf Assy. (Platter) (Incls. Item 16).....	1
2	00-445084	Brace Assy.....	1
3	SC-129-51	Cap Screw 5/16-18 x 3/4 Hex Washer Hd. (SST).....	4
4	NS-048-40	Lock Nut 5/16-18 Flange (SST).....	4
5	00-445107-00001	Support - Shelf (LH).....	1
6	00-445107-00002	Support - Shelf (RH).....	1
7	NS-049-06	Lock Nut 1/4-20 (SST).....	6
8	00-444542	Bracket - Shelf Mounting.....	2
9	SC-129-50	Mach. Screw 1/4-20 x 5/8 Hex Washer Hd. (SST).....	4
10	SC-022-19	Mach. Screw 10-24 x 1/2 Slotted Flat Hd. (SST).....	2
11	00-184135	Spacer - Hinge Block.....	2
12	00-184134	Block - Hinge Mounting.....	2
13	WS-019-06	Washer.....	6
14	SC-067-07	Mach. Screw 10-24 x 1/2 Hex Hd. (SST).....	6
15	SC-122-99	Cap Screw 10-24 x 1/2 Hex Socket Hd.....	4
16	00-184132	Hinge - Shelf.....	2
	00-444449	Standoff - Sealer Cover.....	2
	WS-003-49	Washer 0.266 x 0.563 x 0.062 (SST).....	2
	SC-053-05	Mach. Screw 10-24 x 3/8 Slotted Truss Hd. (SST).....	2
	NS-038-13	Lock Nut 10-24 Hex.....	2

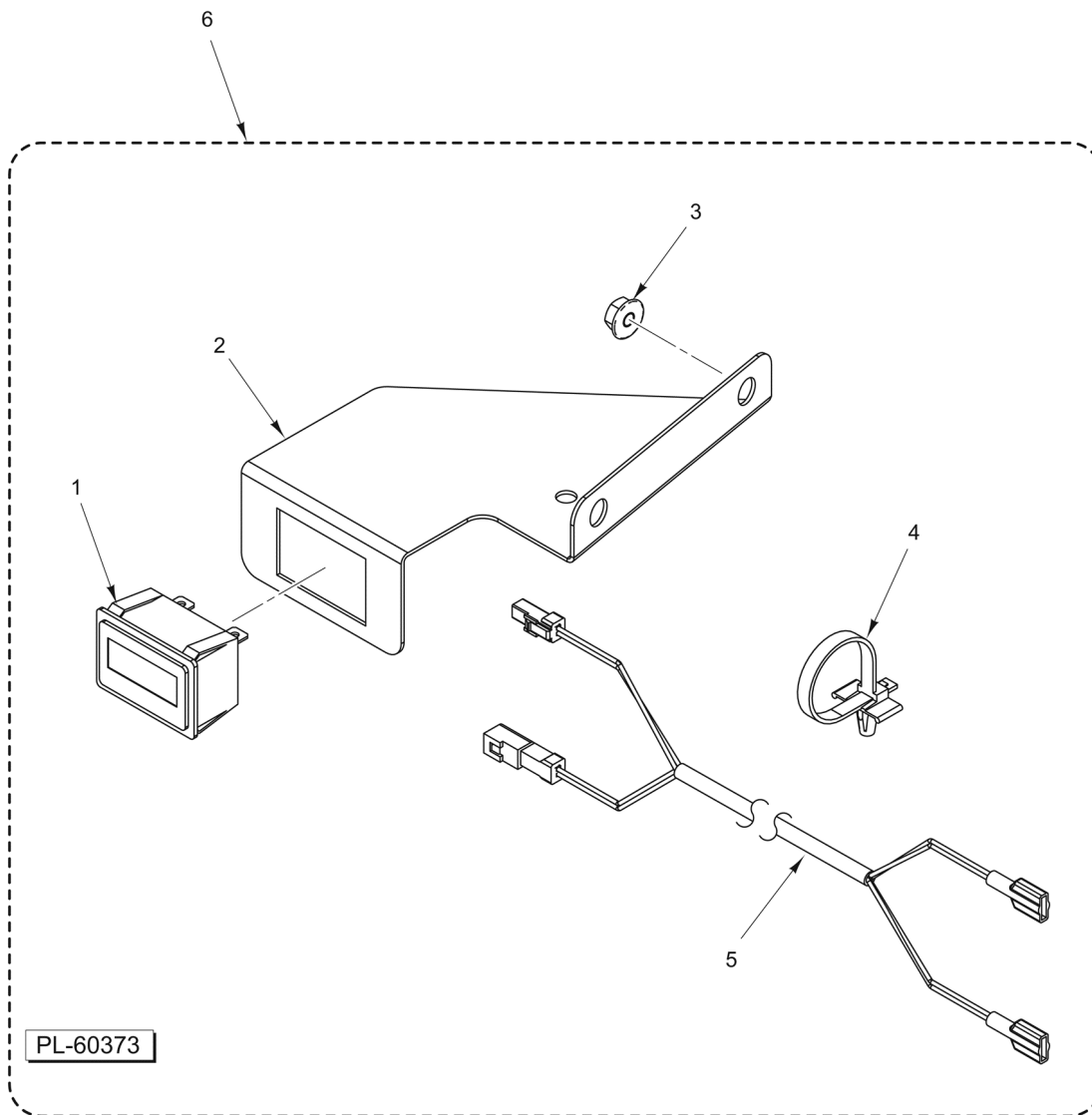

CYCLE COUNTER

CYCLE COUNTER

ILLUS. PL-60373	PART NO.	NAME OF PART	AMT.
1	00-446975	Counter - Cycle.....	1
2	00-446976	Bracket - Counter.....	1
3	NS-048-40	Lock Nut 5/16-18 Flange (SST).....	2
4	00-444428	Tie - Cable Releasable.....	1
5	00-446999	Cable Assy. (Counter).....	1
6	00-446988	Kit - Cycle Counter (Incls. Items 1 thru 5).....	1

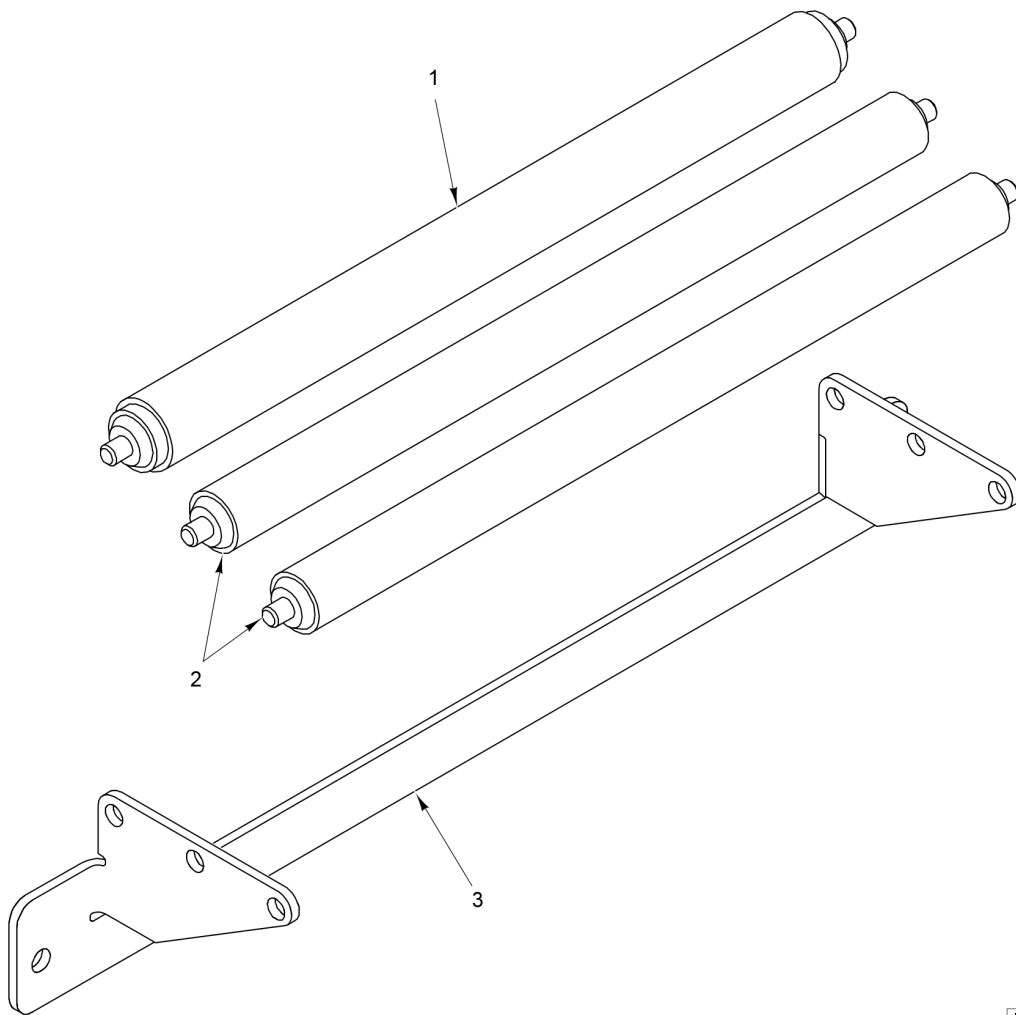

PL-60006

DISCHARGE ROLLER ASSEMBLY

DISCHARGE ROLLER ASSEMBLY

ILLUS. PL-60006	PART NO.	NAME OF PART	AMT.
1	00-444790	Spring Roller Assy. (With Orange Sleeve).....	1
2	00-445040	Roller Assy.....	2
3	00-447238	Bracket - Discharge Rollers.....	1

