



CATALOG OF REPLACEMENT PARTS



MODEL D340 MIXER

(INCLUDES MOTOR PARTS)

D340	ML-134254
D340C	ML-134257

PRIOR MLS COVERED IN THIS CATALOG

D340	ML-134185
D340C	ML-134188
D340 W/O Brake	ML-104483
D340 W/Brake	ML-104484
D340C	ML-134118

Table of Contents

5	TIMER CONTROL AND SWITCH UNIT
7	ELECTRICAL COMPONENT PANEL – 1 PHASE
9	ELECTRICAL COMPONENT PANEL – 3 PHASE
11	BASE AND COLUMN (ML-104483, ML-104484, & ML-134118)
13	BASE AND COLUMN (ML-134185, ML-134188, ML-134254, & ML-134257)
15	BOWL SUPPORT (ML-104483, ML-104484, & ML-134118)
17	BOWL SUPPORT AND LIFT UNIT (ML-134185, ML-134188, ML-134254, & ML-134257)
19	TRANSMISSION CASE
21	SHIFTER UNIT
22	MOTOR PARTS – 1 PHASE (*NON GE MOTORS)
23	MOTOR PARTS – 1 PHASE (GENERAL ELECTRIC)
24	MOTOR PARTS – 3 PHASE (*NON GE MOTORS)
25	MOTOR PARTS – 3 PHASE (GENERAL ELECTRIC)
27	TRANSMISSION
29	PLANETARY AND ATTACHMENT HUB
31	BOWL GUARD UNIT (PREVIOUS CONSTRUCTION)
33	BOWL GUARD UNIT (CURRENT CONSTRUCTION)
34	BRAKE UNIT
35	BOWL
36	AGITATORS

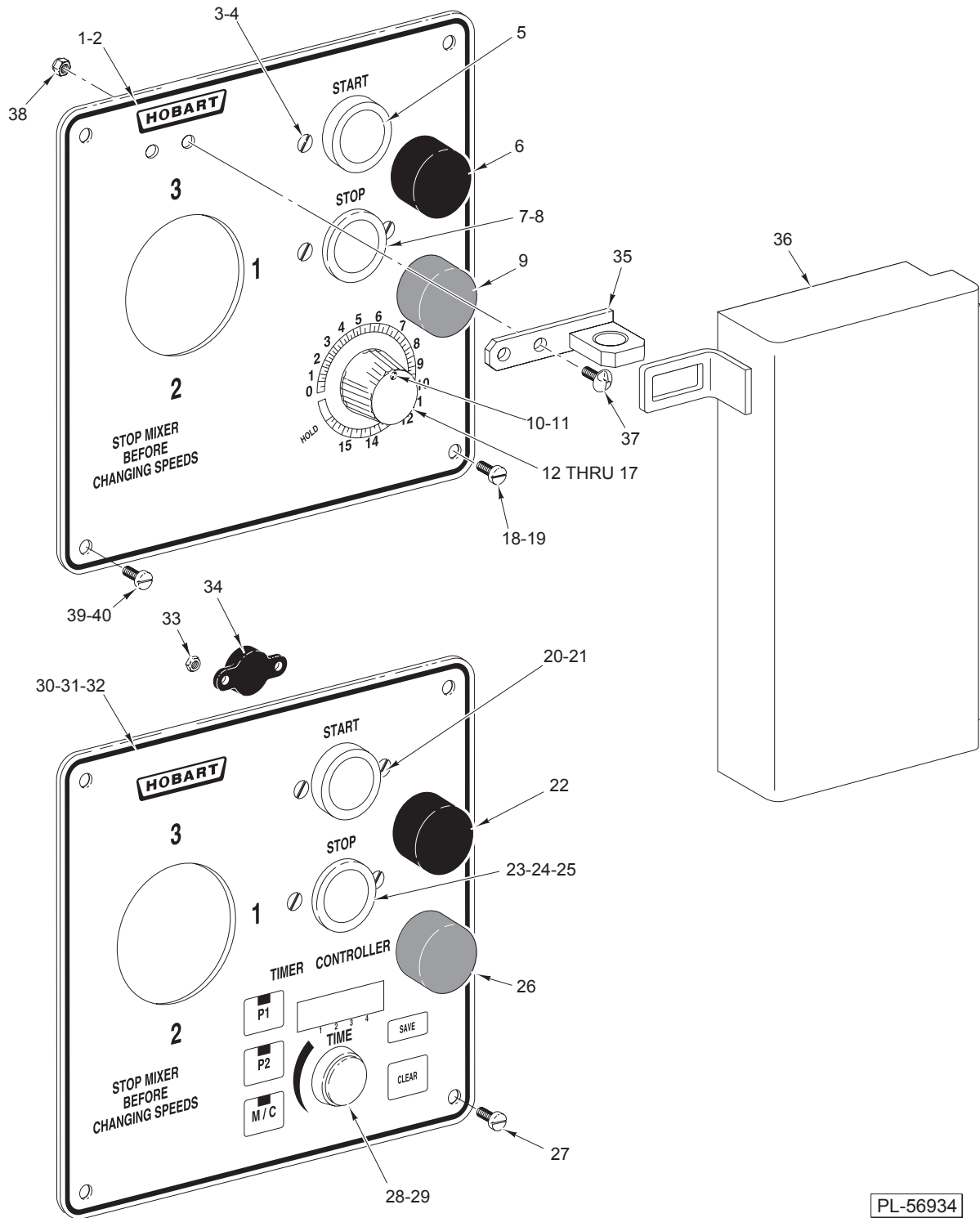

PL-56934

TIMER CONTROL AND SWITCH UNIT

TIMER CONTROL AND SWITCH UNIT

ILLUS.	PART NO.	NAME OF PART	AMT.
PL-56934			
1	00-271312	Plate – Switch & Timer (ML-104483, ML-104484, ML-134185, & ML-134254)	1
2	00-271312	Plate – Switch & Timer (ML-134118, ML-134188, & ML-134257)	1
3	SC-013-12	Mach. Screw 6-32 x 1/4 Slotted Flat Hd. (ML-104483, ML-104484, ML-134185, & ML-134254)	4
4	SC-128-67	Mach. Screw 6-32 x 1/4 Tx. Flat Hd. (SST) (ML-134118, ML-134188, & ML-134257)	4
5	00-087711-183-4	Switch – Push Button (N.O.)	1
6	00-102467-00001	Cap – Push Button (Start) (Black)	1
7	00-087711-183-2	Switch – Push Button (N.C.)	1
8	00-087711-183-3	Switch – Push Button (N.C.) (ML-104484)	1
9	00-102467-00002	Cap – Push Button (Stop) (Red)	1
10	SC-121-89	Mach. Screw 6-32 x 1/4 Hex Flat Hd. (SST) (ML-134118, ML-134188, & ML-134257)	2
11	SC-013-07	Mach. Screw 5-40 x 1/4 Slotted Flat Hd.	2
12	00-291748	Knob – Timer	1
13	00-294650-004-1	Timer Assy. (115 V., 60 Hz.)	1
14	00-294650-004-2	Timer Assy. (200/300 V., 60 Hz.)	1
15	00-294650-004-3	Timer Assy. (415 V., 50 Hz.)	1
16	SC-013-07	Mach. Screw 5-40 x 1/4 Slotted Flat Hd.	2
17	00-271313	Insulator – Timer	1
18	SD-024-01	Self-Tapping Screw 10-24 x 3/8 Slotted Pan Hd., Type TT	2
19	SD-037-59	Self-Tapping Screw 10-24 x 1/2 Hex Button Hd., Type F (ML-134118, ML-134188, & ML-134257)	2
20	00-087711-183-4	Switch – Push Button (N.O.)	1
21	SC-053-38	Mach. Screw 6-32 x 1/4 Slotted Truss Hd.	2
22	00-102467-00001	Cap – Push Button (Start) (Black)	1
23	00-087711-183-2	Switch – Push Button (N.C.)	1
24	00-087711-183-4	Switch – Push Button (N.C.) (ML-104484)	1
25	SC-053-38	Mach. Screw 6-32 x 1/4 Slotted Truss Hd. (SST)	2
26	00-102467-00002	Cap – Push Button (Stop) (Red)	1
27	SD-024-01	Self-Tapping Screw 10-24 x 3/8 Slotted Pan Hd., Type TT	4
28	00-437775	Knob – Potentiometer	1
29	00-437742	Seal – Shaft	1
30	00-438323-00001	Switch Plate & Keypad Assy. (120 VAC)	1
31	00-439400-00001	Board Assy. (120 VAC)	1
32	00-439400-00002	Board Assy. (240 VAC)	1
33	NS-046-17	Stop Nut 4-40 Hex	2
34	00-438499	Buzzer Assy.	1
35	00-477670	Hasp Weldment (ML-134118, ML-134188, & ML-134257)	1
36	00-477667	Cover Assy. & Hinge (ML-134118, ML-134188, & ML-134257)	1
37	SC-128-69	Mach. Screw 10-24 x 3/8 Tx. Button Hd. (SST) (ML-134118, ML-134188, & ML-134257)	2
38	NS-032-01	Lock Nut 10-24 Hex (ML-134118, ML-134188, & ML-134257)	2
39	SD-024-01	Self-Tapping Screw 10-24 x 3/8 Slotted Pan Hd., Type TT	2
40	SD-037-58	Self-Tapping Screw 10-24 x 3/8 Hex Button Hd., Type F (ML-134118, ML-134188, & ML-134257)	2

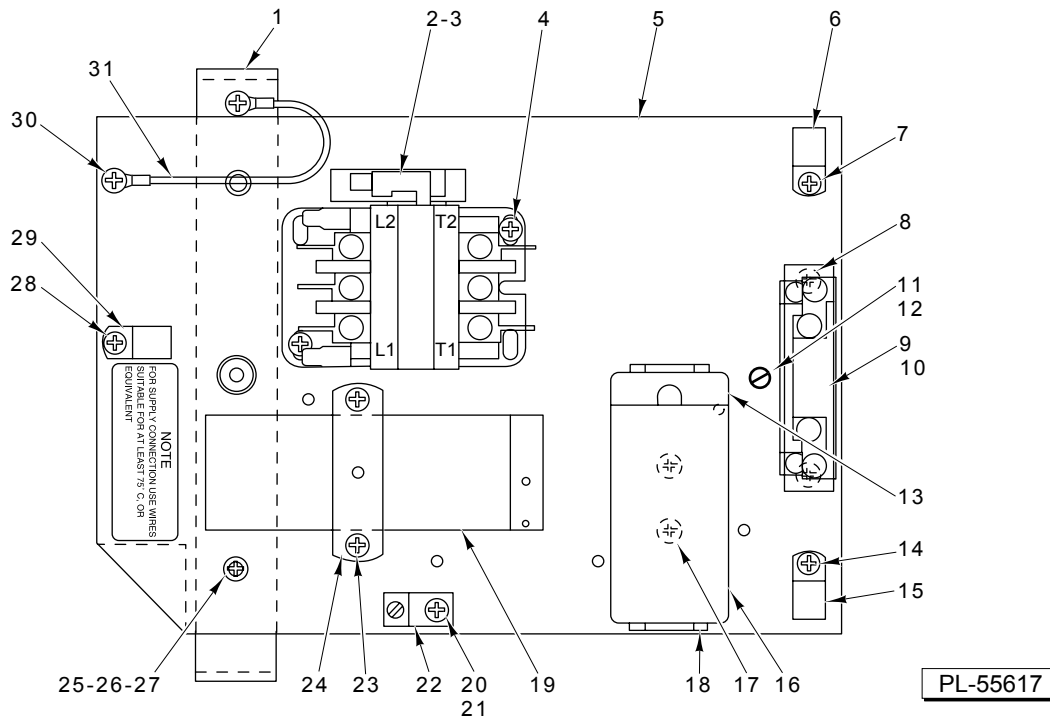

ELECTRICAL COMPONENT PANEL – 1 PHASE

ELECTRICAL COMPONENT PANEL – 1 PHASE

ILLUS.	PART NO.	NAME OF PART	AMT.
PL-55617			
1	00-274031	Bracket – Support (Component Panel) (Top Cover)	1
2	00-087713-037-2	Contactora (115 V., 60 Hz., 1 Ph.) (30 Amp.) (2 Pole)	1
3	00-087713-037-1	Contactora (208/240 V., 60 Hz., 1 Ph.) (30 Amp.) (2 Pole)	1
4	SD-015-20	Self-Tapping Screw 10-32 x 3/8 Phil. Pan Hd., Type TT	2
5	00-274027	Panel – Component Mounting	1
6	00-078752-00009	Clamp – Cable	1
7	SD-015-20	Self-Tapping Screw 10-32 x 3/8 Phil. Pan Hd., Type TT	1
8	SD-015-20	Self-Tapping Screw 10-32 x 3/8 Phil. Pan Hd., Type TT	2
9	00-088196-006-1	Relay – Thermal Overload (1 Ph.)	1
10	*	Heater Element (Overload Relay)	AR
11	SC-060-03	Mach. Screw 10-24 x 3/4 Slotted Rd. Hd.	1
12	WL-007-12	Lockwasher #10 External Shakeproof	1
**13	00-070486-00002	Cap – Capacitor End	1
14	SD-015-20	Self-Tapping Screw 10-32 x 3/8 Phil. Pan Hd., Type TT	1
15	00-078752-00009	Clamp – Cable	1
**16	00-070487-00018	Capacitor (Motor Start)	1
**17	SD-029-06	Self-Tapping Screw 10-24 x 1/2 Phil. Flat Hd., Type F (SST)	2
**18	00-066621-00001	Bracket – Capacitor (Motor Start)	1
**19	00-274034	Capacitor (Motor Run)	1
20	SD-015-20	Self-Tapping Screw 10-32 x 3/8 Phil. Pan Hd., Type TT	1
21	WL-007-12	Lockwasher #10 External Shakeproof	2
22	00-118544-00001	Lug – Solderless	1
**23	SD-015-20	Self-Tapping Screw 10-32 x 3/8 Phil. Pan Hd., Type TT	2
**24	00-274032	Bracket – Capacitor (Motor Run)	1
25	00-274033	Nut – Well (Component Bracket)	2
26	SC-060-85	Mach. Screw 10-24 x 1 Slotted Rd. Hd.	2
27	WL-007-12	Lockwasher #10 External Shakeproof	2
28	SD-015-20	Self-Tapping Screw 10-32 x 3/8 Phil. Pan Hd., Type TT	1
29	00-078752-00009	Clamp – Cable	1
30	SD-015-20	Self-Tapping Screw 10-32 x 3/8 Phil. Pan Hd., Type TT	2
31	00-087525-00669	Lead Wire Assy.	1
	00-113703	Cable Tie	AR

*Give Elec. Spec., Mach. Model, & Motor Type.

**GE Motor Capacitors Mounted on Motor, Not Serviceable (See Page 23).

ELECTRICAL COMPONENT PANEL – 3 PHASE

ILLUS. PL-55722	PART NO.	NAME OF PART	AMT.
1	00-274031	Bracket – Support (Component Panel) (Top Cover)	1
2	00-087713-080-1	Contactors (208/240 V., 60 Hz., 3 Ph.) (30 Amp.) (3 Pole)	1
**3	00-087713-080-2	Contactors (480 V., 60 Hz., 3 Ph.) (30 Amp.) (3 Pole)	1
4	SD-015-20	Self-Tapping Screw 10-32 x 3/8 Phil. Pan Hd., Type TT	2
5	00-274027	Panel – Component Mounting	1
6	00-078752-00009	Clamp – Cable	1
7	SD-015-20	Self-Tapping Screw 10-32 x 3/8 Phil. Pan Hd., Type TT	1
8	00-088196-005-1	Relay – Thermal Overload (3 Ph.)	1
9	*	Heater Element (Overload Relay)	AR
10	SC-060-03	Mach. Screw 10-24 x 3/4 Slotted Rd. Hd.	1
11	WL-007-12	Lockwasher #10 External Shakeproof	1
12	SD-015-20	Self-Tapping Screw 10-32 x 3/8 Phil. Pan Hd., Type TT	1
13	SD-033-72	Self-Tapping Screw 10-32 x 7/8 Phil. Pan Hd., Type TT	2
14	00-271336	Terminal Block	1
15	SD-015-20	Self-Tapping Screw 10-32 x 3/8 Phil. Pan Hd., Type TT	1
16	00-078752-00009	Clamp – Cable	1
**17	00-294436-00003	Block – Fuse	1
**18	FE-017-03	Fuse (2 Amp.) (W/Brake)	1
**19	FE-009-25	Fuse (0.5 Amp.)	1
**20	SD-015-38	Self-Tapping Screw 6-32 x 3/8 Phil. Pan Hd., Type TT	1
**21	SD-015-20	Self-Tapping Screw 10-32 x 3/8 Phil. Pan Hd., Type TT	1
22	SD-015-20	Self-Tapping Screw 10-32 x 3/8 Phil. Pan Hd., Type TT	1
23	WL-007-12	Lockwasher #10 External Shakeproof	2
24	00-118544-00001	Lug – Solderless	1
**25	00-101935	Transformer	1
**26	00-436960	Transformer (W/Brake)	1
27	00-274033	Nut – Well (Component Bracket)	2
28	SC-060-85	Mach. Screw 10-24 x 1 Slotted Rd. Hd.	2
29	WL-007-12	Lockwasher #10 External Shakeproof	2
30	SD-015-20	Self-Tapping Screw 10-32 x 3/8 Phil. Pan Hd., Type TT	1
31	00-078752-00009	Clamp – Cable	1
32	SD-015-20	Self-Tapping Screw 10-32 x 3/8 Phil. Pan Hd., Type TT	2
33	00-087525-00669	Lead Wire Assy.	1
	00-113703	Cable Tie	AR

*Give Elec. Spec., Mach. Model, & Motor Type.

**Above 250 V. Machines.

**BASE AND COLUMN
(ML-104483, ML-104484, & ML-134118)**

ILLUS. PL-57868	PART NO.	NAME OF PART	AMT.
1	00-437824	Cover – Bowl Support	1
2	00-070641-00001	Thumb Screw (ML-104483 & ML-104484)	4
3	SC-128-74	Mach. Screw 1/4-20 x 5/8 Tx. Button Hd. (SST) (ML-134118)	4
4	SC-061-06	Cap Screw 5/16-18 x 1 3/4 Hex Flat Hd.	10
5	00-435267	Gib – Upper	2
6	00-435264-00001	Shim – Gib (0.003 Thk.)	AR
7	00-435264-00002	Shim – Gib (0.005 Thk.)	AR
8	00-435264-00003	Shim – Gib (0.010 Thk.)	AR
9	00-435265	Gib – Center	2
10	00-435266	Gib – Lower	2
11	SC-023-19	Mach. Screw 1/4-20 x 3/4 Slotted Oval Hd. (SST) (ML-104483 & ML-104484)	2
12	SC-128-64	Mach. Screw 1/4-20 x 1 Tx. Flat Hd. (SST) (ML-134118)	2
13	00-274038	Cover – Top Assy. (Incls. Item 14)	1
14	00-123687-00007	Gasket	1
15	00-435230	Vent – Air Intake (1 Ph.) (ML-104484)	1
16	00-435270	Gasket – Air	1
17	00-274668	Vent – Air Intake (1 Ph.) (ML-104483)	1
18	00-435236	Cover – Motor (3 Ph.) (ML-104484)	1
19	00-271300-00001	Cover – Motor (3 Ph.) (ML-104483)	1
20	SC-053-41	Mach. Screw 1/4-20 x 1/2 Slotted Truss Hd. (SST) (ML-104483 & ML-104484)	2
21	00-875377	Cover – Motor (ML-134118)	1
22	SC-128-74	Mach. Screw 1/4-20 x 5/8 Tx. Button Hd. (SST) (ML-134118)	2
23	SC-053-41	Mach. Screw 1/4-20 x 1/2 Slotted Truss Hd. (SST) (ML-104483 & ML-104484)	1
24	SC-128-74	Mach. Screw 1/4-20 x 5/8 Tx. Button Hd. (SST) (ML-134118)	1
25	00-271299-00001	Cover – Lift Mechanism	1
26	00-875476-00002	Column	1
27	00-271227-002-2	Base Assy.	1
28	WL-004-11	Lockwasher 1/2 Medium	4
29	SC-120-28	Cap Screw 1/2-13 x 2 Hex Hd.	4
30	00-087668-00002	Caster	4
31	00-875748	Bowl Truck Assy.	1
32	00-018682-00001	Bumper	4
33	SC-047-30	Set Screw 5/16-18 x 5/16 Hdls., Flat Pt.	2
34	SC-112-65	Set Screw 5/16-18 x 3/4 Hdls., Cone Pt.	2
35	00-011800-00118	Dowel	2
36	SC-036-26	Cap Screw 5/16-18 x 7/8 Hex Hd.	2
37	WL-003-41	Lockwasher 5/16 Light	2
38	00-438596	Bracket – Switch	1
39	00-438625	Insulator	1
40	00-087711-00248	Switch – Bowl Height	1
41	SC-021-05	Mach. Screw 4-40 x 5/8 Slotted Rd. Hd. (SST)	2
42	WL-003-01	Lockwasher #4 Light	2
43	WL-003-41	Lockwasher 5/16 Light	1
44	NS-013-14	Nut 5/16-18 Hex	1
45	00-078752-00011	Clamp – Wire	1
46	SC-119-53	Mach. Screw 8-32 x 3/4 Slotted Pan Hd. (SST)	1
47	SC-128-66	Mach. Screw 8-32 x 1/2 Tx. Button Hd. (SST) (ML-134118)	1
48	WS-019-16	Washer	1
49	WL-007-07	Lockwasher #8 External Shakeproof	1
50	NS-009-12	Mach. Nut 8-32 Hex	1

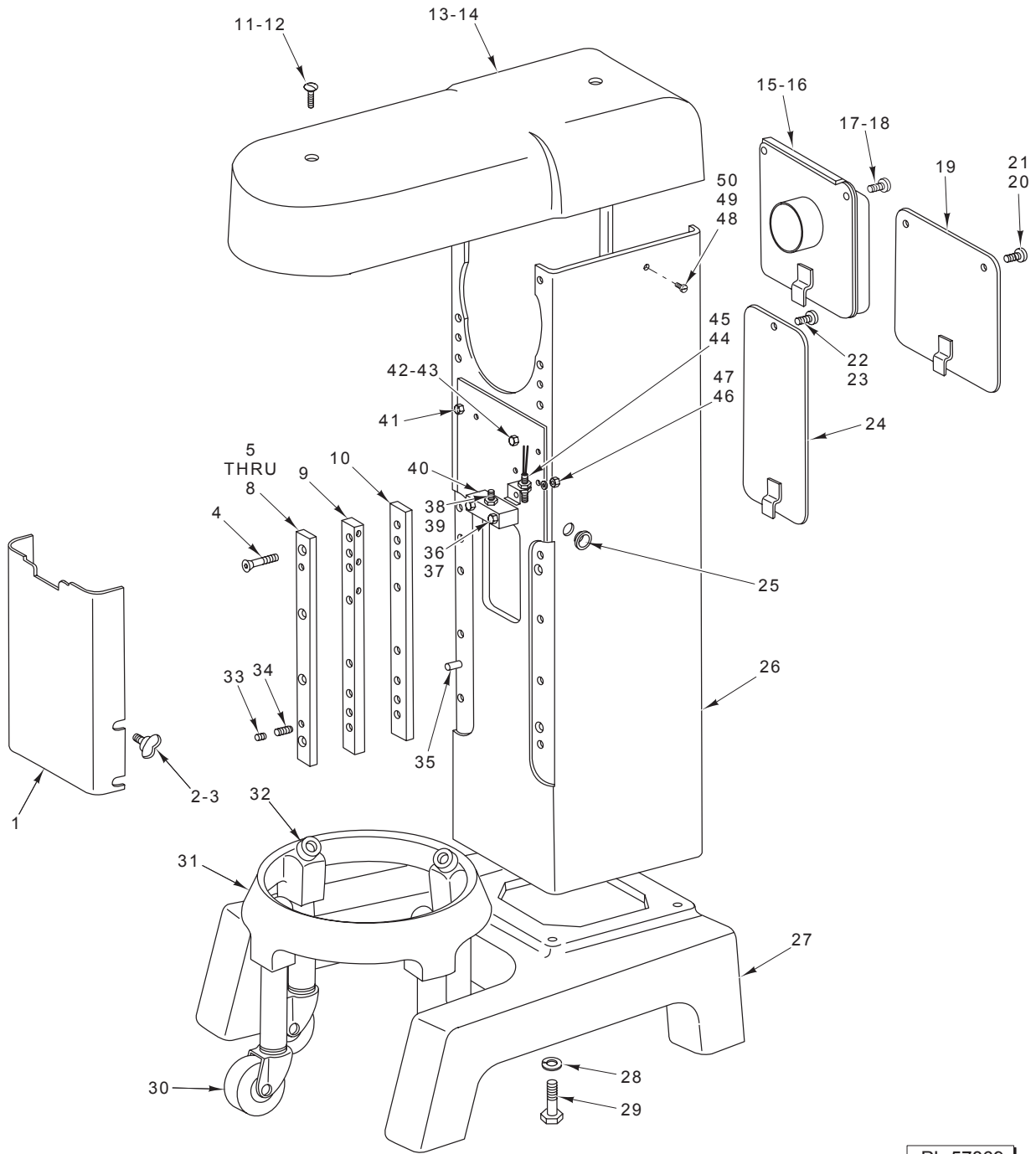

PL-57869

**BASE AND COLUMN
(ML-134185, ML-134188, ML-134254, & ML-134257)**

**BASE AND COLUMN
(ML-134185, ML-134188, ML-134254, & ML-134257)**

ILLUS. PL-57869	PART NO.	NAME OF PART	AMT.
1	00-435262	Cover – Bowl Support	1
2	00-070641-00001	Thumb Screw (ML-134185 & ML-134254)	4
3	SC-128-74	Mach. Screw 1/4-20 x 5/8 Tx. Button Hd. (SST) (ML-134188 & ML-134257)	4
4	SC-061-06	Cap Screw 5/16-18 x 1 3/4 Hex Flat Hd.	10
5	00-435267	Gib – Upper	2
6	00-435264-00001	Shim – Gib (0.003 Thk.)	AR
7	00-435264-00002	Shim – Gib (0.005 Thk.)	AR
8	00-435264-00003	Shim – Gib (0.010 Thk.)	AR
9	00-435265	Gib – Center	2
10	00-435266	Gib – Lower	2
11	SC-023-19	Mach. Screw 1/4-20 x 3/4 Slotted Oval Hd. (SST) (ML-134185)	2
12	SC-128-64	Mach. Screw 1/4-20 x 1 Tx. Flat Hd. (SST) (ML-134188 & ML-134257)	2
13	00-274038	Cover – Top Assy. (Incls. Item 14)	1
14	00-123687-00007	Gasket	1
15	00-435270	Gasket – Air Intake	1
16	00-479512	Vent – Air Intake (1 Ph.)	1
17	SC-053-41	Mach. Screw 1/4-20 x 1/2 Slotted Truss Hd. (SST) (ML-134185)	2
18	SC-121-38	Mach. Screw 1/4-20 x 5/8 Hex Button Hd. (SST) (ML-134188)	2
19	00-875377	Cover – Motor (3 Ph.)	1
20	SC-053-41	Mach. Screw 1/4-20 x 1/2 Slotted Truss Hd. (SST) (ML-134185)	2
21	SC-128-74	Mach. Screw 1/4-20 x 5/8 Tx. Button Hd. (SST) (ML-134188)	2
22	SC-053-41	Mach. Screw 1/4-20 x 1/2 Slotted Truss Hd. (SST) (ML-134185 & ML-134254)	1
23	SC-128-74	Mach. Screw 1/4-20 x 5/8 Tx. Button Hd. (SST) (ML-134188 & ML-134257)	1
24	00-271299-00001	Cover – Lift Mechanism	1
25	00-271343	Grommet – Handle	1
26	00-875476-00002	Column	1
27	00-271227-002-2	Base Assy.	1
28	WL-004-11	Lockwasher 1/2 Medium	4
29	SC-120-28	Cap Screw 1/2-13 x 2 Hex Hd.	4
30	00-087668-00002	Caster	4
31	00-875748	Bowl Truck Assy.	1
32	00-018682-00001	Bumper	4
33	SC-047-30	Set Screw 5/16-18 x 5/16 Hdls., Flat Pt.	2
34	SC-112-65	Set Screw 5/16-18 x 3/4 Hdls., Cone Pt.	2
35	00-011800-00118	Dowel	2
36	SC-036-11	Cap Screw 1/4-20 x 2 Hex Hd.	2
37	WL-006-16	Lockwasher 1/4 Light	2
38	SC-109-85	Set Screw 5/16-18 x 1 1/2 Hdls., Oval Pt.	1
39	NS-017-08	Jam Nut 5/16-18 Hex	1
40	00-271267	Block – Stop	1
41	SC-063-33	Set Screw 3/8-16 x 3/8 Hdls., Flat Pt.	2
42	SC-036-06	Cap Screw 1/4-20 x 1 Hex Hd.	4
43	WL-006-16	Lockwasher 1/4 Light	4
44	00-087711-306-1	Switch – Bowl Height Sensing	1
45	00-438577	Bracket – Sensor	1
46	WL-006-16	Lockwasher 1/4 Light (SST) (Use to Mount Item 40)	1
47	NS-013-02	Nut 1/4-20 Hex (Use to Mount Item 40)	1
48	SC-053-46	Mach. Screw 1/4-20 x 3/4 Slotted Truss Hd. (SST)	2
49	SC-124-50	Mach. Screw 1/4-20 x 3/4 Tx. Button Hd. (SST)	2
50	00-522815	Loctite 271 Size 31 (50cc)	2

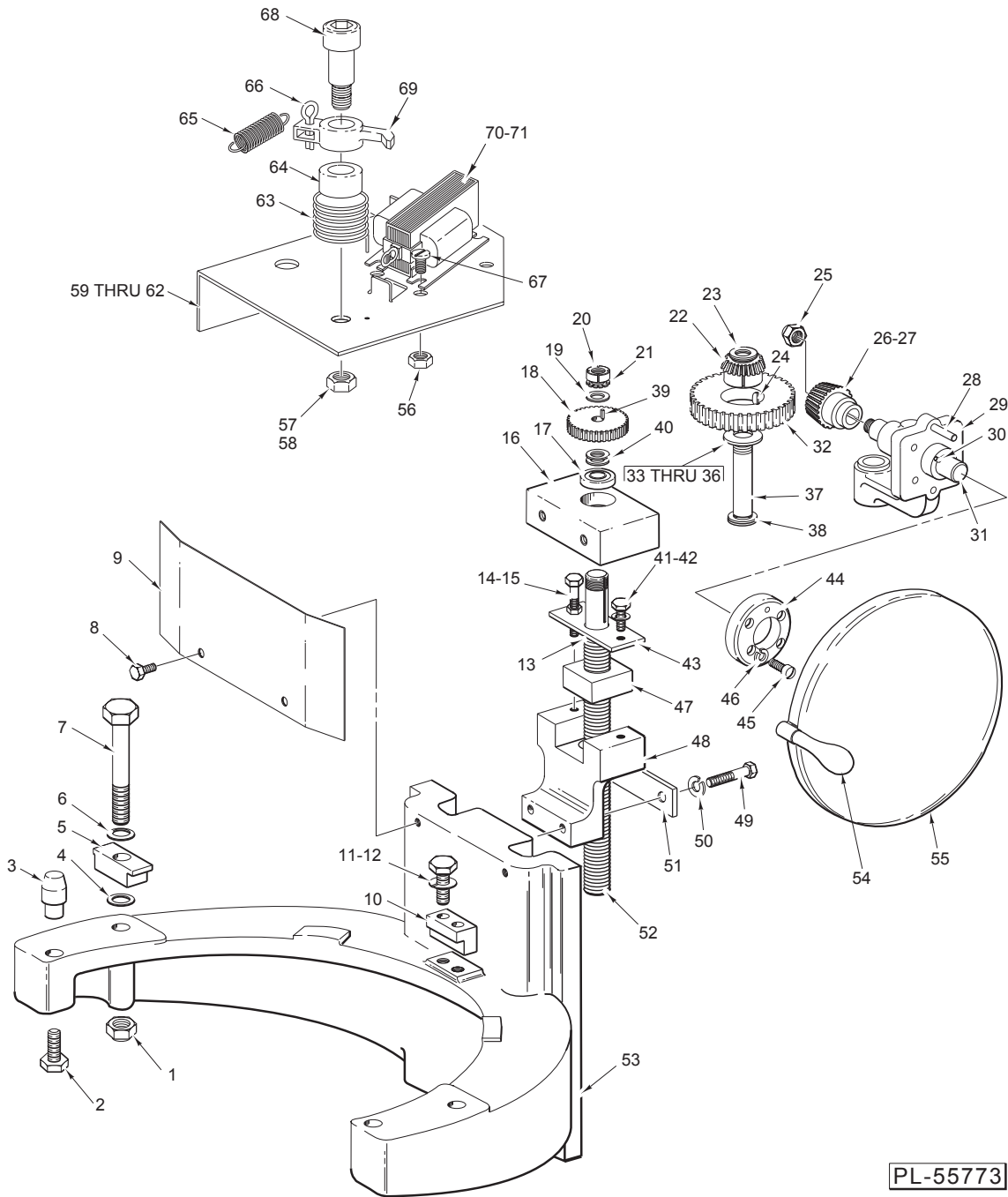

BOWL SUPPORT
(ML-104483, ML-104484, & ML-134118)

ILLUS.	PART NO.	NAME OF PART	AMT.
	PL-55773		
1	NS-032-13	Lock Nut ⁵ / ₁₆ -18 Flexloc	2
2	SC-037-75	Cap Screw ⁵ / ₁₆ -18 x ³ / ₄ Hex Hd.	2
3	00-070411	Pin – Bowl Locating	2
4	WS-004-18	Washer	2
5	00-070057	Clamp – Bowl	2
6	00-070087	Washer – Spring	2
7	SC-062-28	Cap Screw ⁵ / ₁₆ -18 x ³ / ₂ Hex Hd.	2
8	SC-068-14	Mach. Screw 8-32 x ³ / ₈ Hex Hd.	2
9	00-435262	Cover – Bowl Support	1

**BOWL SUPPORT
(ML-104483, ML-104484, & ML-134118) (CONT.)**

ILLUS.	PART NO.	NAME OF PART	AMT.
PL-55773			
10	00-070044	Retainer – Bowl.....	1
11	SC-036-09	Cap Screw 1/4-20 x 1 1/4 Hex Hd.	2
12	WL-006-16	Lockwasher 1/4 Light (SST)	2
13	WS-010-17	Washer	1
14	NS-017-16	Jam Nut 3/8-16 Hex	1
15	SC-124-91	Cap Screw 3/8-16 x 2 1/2 Hex Hd.	1
16	00-435252-00002	Bearing – Bowl Lift Screw	1
17	BB-005-30	Ball Bearing	1
18	00-024193	Gear – Bowl Lift Screw (31T)	1
19	WS-010-17	Washer	1
20	NS-034-04	Lock Nut N.D. #N-03	1
21	WL-012-04	Lockwasher N.D. #W-03	1
22	00-024195-00002	Gear – Bowl Lift Miter (23T)	1
23	RR-005-02	Retaining Ring (Spirolox)	1
24	KW-003-03	Key – Woodruff 1/8 x 1/2 Lg.	1
25	NS-032-29	Stop Nut 1/2-20 Flexloc	1
26	00-024196-00002	Pinion – Bowl Lift Miter (23T)	1
27	00-012430-00041	Key 3/16 Sq. x 5/8 Lg.	1
28	RP-002-06	Roll Pin 1/4 Dia. x 1 Lg.	2
29	00-089684	Handwheel Bracket & Bearing Assy.	1
30	PG-007-19	Grooved Pin – Type E 1/4 x 2 3/4	1
31	00-024191	Shaft – Hand Wheel	1
32	00-024192	Gear – Bowl Lift (41T)	1
33	00-024614-00003	Washer – Miter Gear Spacer (0.086 Thk.)	AR
34	00-024614-00004	Washer – Miter Gear Spacer (0.081 Thk.)	AR
35	00-024614-00005	Washer – Miter Gear Spacer (0.076 Thk.)	AR
36	00-024614-00006	Washer – Miter Gear Spacer (0.071 Thk.)	AR
37	00-024194	Shaft – Miter Gear	1
38	RR-005-02	Retaining Ring (Spirolox)	1
39	00-012430-00043	Key 3/16 Sq. x 7/16 Lg.	1
40	WS-010-17	Washer	2
41	SC-036-53	Cap Screw 3/8-16 x 7/8 Hex Hd.	1
42	WL-004-06	Lockwasher 3/8 Light	1
43	00-024201	Retainer – Bowl Lift Nut	1
44	00-024609-00001	Ring – Handwheel Bracket Clamping	1
45	SC-011-95	Mach. Screw 5/16-18 x 1 Fil. Hd.	4
46	WL-003-48	Lockwasher 5/16 High Collar	4
47	00-024198	Nut – Bowl Lift Screw	1
48	00-435268-00002	Lift – Bowl	1
49	SC-037-69	Cap Screw 3/8-18 x 1 3/4 Hex Hd.	2
50	WL-003-41	Lockwasher 5/16 Light	2
51	00-438597	Bar – Switch	1
52	00-290052-00001	Screw – Bowl Lift	1
53	00-435269-00002	Support – Bowl	1
54	00-024765	Handle – Bowl Lift Handwheel	1
55	00-435235	Hand Wheel & Handle Assy. (Incls. Item 54)	1
56	NS-048-20	Stop Nut 10-24	4
57	NS-048-17	Stop Nut 3/8-16 Flexloc	1
58	NS-048-24	Lock Nut 3/8-16 (ML-134118)	1
59	00-438600	Plate – Bowl Lock	1
60	SC-053-46	Mach. Screw 1/4-20 x 3/4 Slotted Truss Hd. (SST)	2
61	WS-003-07	Washer	2
62	NS-032-08	Stop Nut 1/4-20 Flexloc	2
63	00-438575	Spring – Torsion	1
64	00-438516	Spacer – Lever	1
65	00-438494	Spring – Extension	1
66	PC-006-32	Cotter Pin	1
67	SC-018-20	Mach. Screw 10-24 x 1/2 Slotted Pan Hd.	4
68	SC-086-24	Shoulder Screw 1/2 Dia. x 1 1/2 Soc. Hex Hd.	1
69	00-438413-00002	Lever – Bowl Lock	1
70	00-875737-00001	Solenoid (115 V. Coil)	1
71	00-875737-00002	Solenoid (230 V. Coil)	1

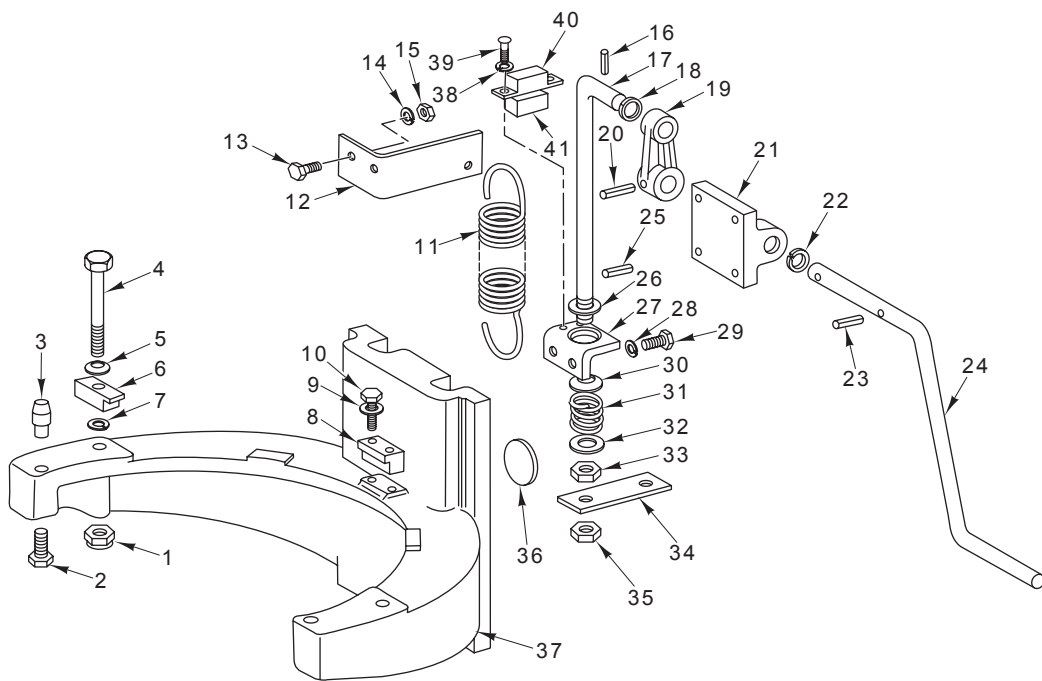

PL-55618

**BOWL SUPPORT AND LIFT UNIT
(ML-134185, ML-134188, ML-134254, & ML-134257)**

**BOWL SUPPORT AND LIFT UNIT
(ML-134185, ML-134188, ML-134254, & ML-134257)**

ILLUS. PL-55618	PART NO.	NAME OF PART	AMT.
1	NS-036-19	Stop Nut ⁵ / ₁₆ -18 Hex (SST)	2
2	SC-037-75	Cap Screw ⁵ / ₁₆ -18 x ³ / ₄ Hex Hd.	2
3	00-070411	Pin – Bowl Locating	2
4	SC-062-28	Cap Screw ⁵ / ₁₆ -18 x 3 ¹ / ₂ Hex Hd.	2
5	00-070087	Washer – Spring	2
6	00-070057	Clamp – Bowl	2
7	WS-004-18	Washer	2
8	00-070044	Retainer – Bowl	1
9	WL-006-16	Lockwasher ¹ / ₄ Light (SST)	2
10	SC-036-09	Cap Screw ¹ / ₄ -20 x 1 ¹ / ₄ Hex Hd.	2
11	00-271342	Spring – Counterbalance	1
12	00-271345	Bracket – Spring	1
13	SC-036-06	Cap Screw ¹ / ₄ -20 x 1 Hex Hd.	2
14	WL-006-16	Lockwasher ¹ / ₄ Light (SST)	2
15	NS-013-02	Nut ¹ / ₄ -20 Hex	2
16	RP-002-25	Roll Pin ¹ / ₈ Dia. x ⁷ / ₈ Lg.	1
17	00-068718	Rod – Bowl Lift	1
18	WS-008-47	Washer	1
19	00-271259-00002	Arm – Bowl Lift	1
20	RP-002-26	Roll Pin ¹ / ₄ Dia. x 1 ¹ / ₈ Lg.	1
21	00-271269-00002	Bearing – Bowl Lift Handle	1
22	WS-020-01	Washer (SST)	1
23	RP-002-25	Roll Pin ¹ / ₈ Dia. x ⁷ / ₈ Lg.	1
24	00-271322	Handle – Bowl Lift	1
25	RP-002-10	Roll Pin ³ / ₁₆ Dia. x 1 Lg.	1
26	WS-008-47	Washer	1
27	00-438576	Bracket – Lower Lift	1
28	WL-003-41	Lockwasher ⁵ / ₁₆ Light	2
29	SC-037-75	Cap Screw ⁵ / ₁₆ -18 x ³ / ₄ Hex Hd.	2
30	00-070131	Washer – Cup Bowl Lift	1
31	00-070104	Spring – Bowl Lift	1
32	WS-008-47	Washer	1
33	NS-017-31	Jam Nut ¹ / ₂ -20 Hex	1
34	00-271346	Bracket – Lower Spring Lift	1
35	NS-017-31	Jam Nut ¹ / ₂ -20 Hex	1
36	00-271319	Bumper	2
37	00-435269-00001	Support – Bowl	1
38	WL-003-01	Lockwasher #4 Light	2
39	SC-021-01	Mach. Screw 4-40 x ¹ / ₄ Slotted Rd. Hd. (SST)	2
40	00-120332	Retainer – Magnet	1
41	00-111941	Magnet	1

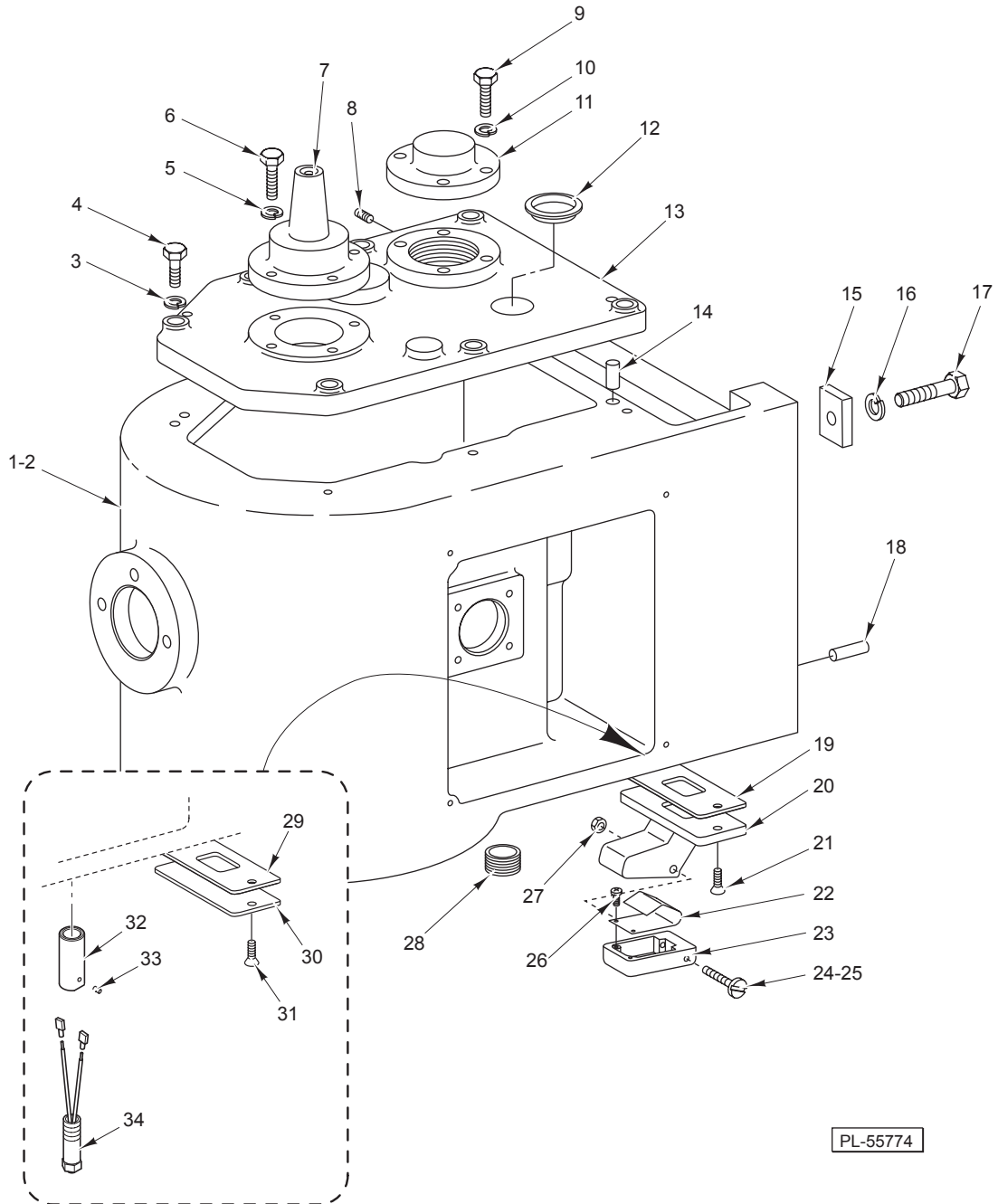

PL-55774

TRANSMISSION CASE

TRANSMISSION CASE

ILLUS. PL-55774	PART NO.	NAME OF PART	AMT.
1	00-271206-002-2	Case – Transmission (ML-104483, ML-104484, & ML-134118)	1
2	00-271206-003-2	Case – Transmission (ML-134185, ML-134188, ML-134254, & ML-134257)	1
3	WL-003-44	Lockwasher ⁵ / ₁₆ Medium	7
4	SC-120-38	Cap Screw ⁵ / ₁₆ -18 x 1 Hex Hd.	7
5	WL-003-37	Lockwasher ¹ / ₄ Medium	4
6	SC-036-06	Cap Screw ¹ / ₄ -20 x 1 Hex Hd.	4
7	00-271222-00002	Retainer – Bearing (Planetary Shaft)	1
8	SC-047-70	Set Screw 10-32 x ³ / ₈ Hdls., Cup Pt.	2
9	SC-036-06	Cap Screw ¹ / ₄ -20 x 1 Hex Hd.	4
10	WL-003-37	Lockwasher ¹ / ₄ Medium	4
11	00-271225-00002	Retainer – Bearing (Worm Gear Shaft)	1
12	00-064871	Plug – Friction	1
13	00-271218-002-1	Transmission Case Cover Assy.	1
14	00-011800-00249	Dowel	2
15	00-271340	Bar – Reinforcing	6
16	WL-004-06	Lockwasher ³ / ₈ Medium	6
17	SC-116-83	Cap Screw ³ / ₈ -16 x 1 ¹ / ₂ Hex Hd.	6
18	00-011800-00118	Dowel	2
19	00-437809	Gasket – Reed Housing	1
20	00-437793-00002	Housing – Reed	1
21	SC-022-22	Mach. Screw 10-24 x ³ / ₄ Slotted Flat Hd. (SST)	2
22	00-437435	Spring – Reed Switch	1
23	00-087711-304-1	Housing – Reed Switch	1
24	SC-122-48	Mach. Screw 8-32 x 1 ³ / ₄ Slotted Rd. Hd. (SST)	1
25	SC-122-75	Mach. Screw 8-32 x 2 Hex Button Hd. (SST) (ML-134118 & ML-134188)	1
26	SC-018-50	Mach. Screw 6-32 x ¹ / ₄ Slotted Pan Hd.	2
27	NS-031-08	Nut – Stop Special 8-32 Hex (SST)	1
28	FP-085-17	Pipe Plug ⁵ / ₈ Hex Socket	1
29	00-437809	Gasket – Reed Housing (ML-134185, ML-134188, ML-134254, & ML-134257)	1
30	00-874974	Plate – Transmission Cover (ML-134185, ML-134188, ML-134254, & ML-134257)	1
31	SC-022-22	Mach. Screw 10-24 x ³ / ₄ Slotted Flat Hd.	2
32	00-874990	Extension – Bowl Guard Switch (ML-134185, ML-134188, ML-134254, & ML-134257)	1
33	SC-075-14	Set Screw 6-32 x ¹ / ₈ Hex Hdls., Cup Pt.	1
34	00-874958	Switch – Reed & Extension (ML-134185, ML-134188, ML-134254, & ML-134257)	1
	00-068288	Shim (Between Trans. Case & Column) (Not Shown)	AR

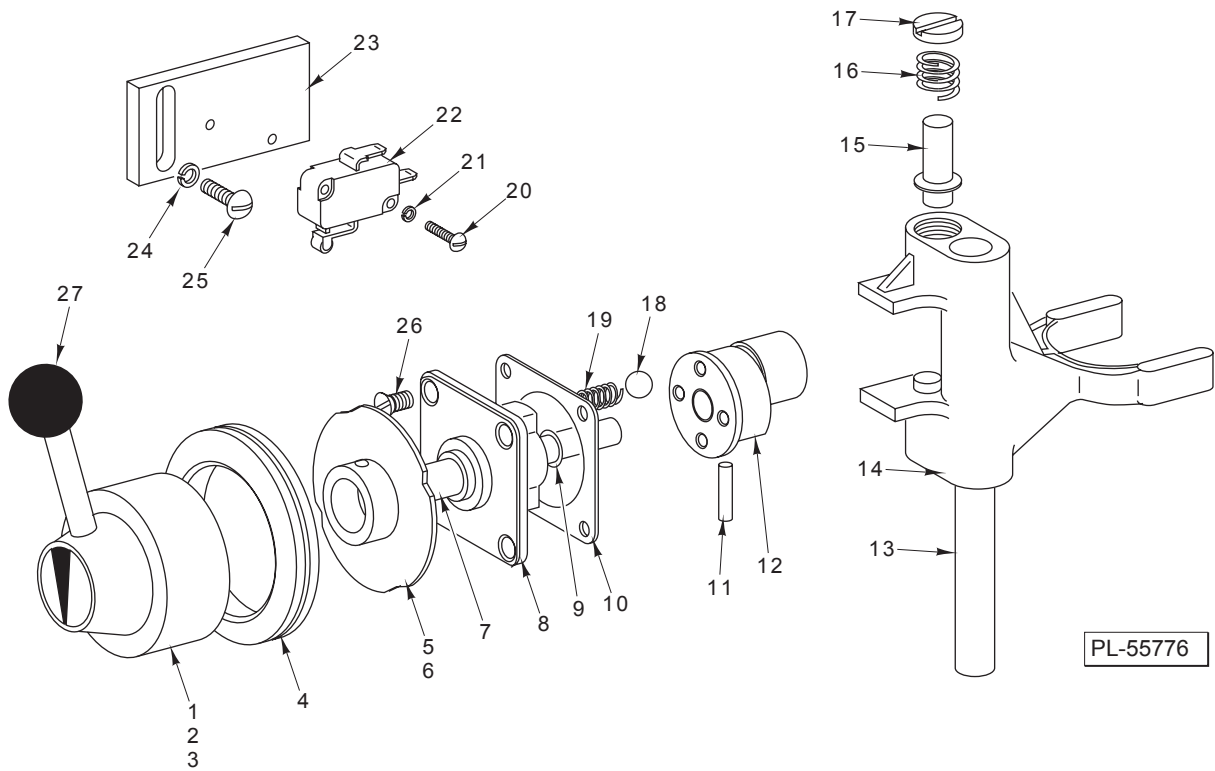

SHIFTER UNIT

SHIFTER UNIT

ILLUS.	PART NO.	NAME OF PART	AMT.
PL-55776			
1	SC-047-17	Set Screw 1/4-20 x 3/4 Hds., Cup Pt.	1
2	00-291272	Shifter Handle Assy. (Incls. Items 1 & 27) (ML-104483, ML-104484, ML-134185, & ML-134254)	1
3	00-439306	Shifter Handle Assy. (Pinned) (Incls. Items 1 & 27) (ML-134118, ML-134188, & ML-134257)	1
4	00-110961	Grommet – Shifter Handle	1
5	00-271276	Cam – Interlock Assy.	1
6	SC-047-70	Set Screw 10-32 x 3/8 Hds., Cup Pt.	1
7	00-875238	Shaft – Shifter	1
8	00-290115-00001	Plate – Index	1
9	00-067500-00044	O-Ring	1
10	00-023946	Gasket – Index Plate	1
11	PS-003-08	Spiral Pin 1/8 Dia. x 3/4 Lg.	1
12	00-873504	Cam – Gear Shifter	1
13	00-271291	Rod – Shifter Guide	1
14	00-271245-00002	Yoke – Shifter	1
15	00-012733	Plunger – Shifter Yoke	2
16	00-012734	Spring – Shifter Yoke	2
17	00-012732	Retainer – Shifter Yoke Spring	2
18	BA-002-09	Ball 1/4 Dia.	2
19	00-111170	Spring – Detent	2
20	SC-021-05	Mach. Screw 4-40 x 5/8 Slotted Rd. Hd. (SST)	2
21	WL-003-01	Lockwasher #4 Light	2
22	00-271315	Switch – Interlock (10 Amp., 250 VAC)	1
23	00-271277	Plate – Switch Mounting	1
24	WL-003-20	Lockwasher #10 Light	2
25	SC-009-25	Mach. Screw 10-24 x 5/8 Slotted Rd. Hd.	2
26	SC-014-57	Mach. Screw 10-24 x 1/2 Slotted Flat Hd.	4
27	00-070085	Knob – Shifter Handle Ball	1
	00-875240	Shifter – Sub-Assy.	1

MODEL D340 MIXER REPLACEMENT PARTS

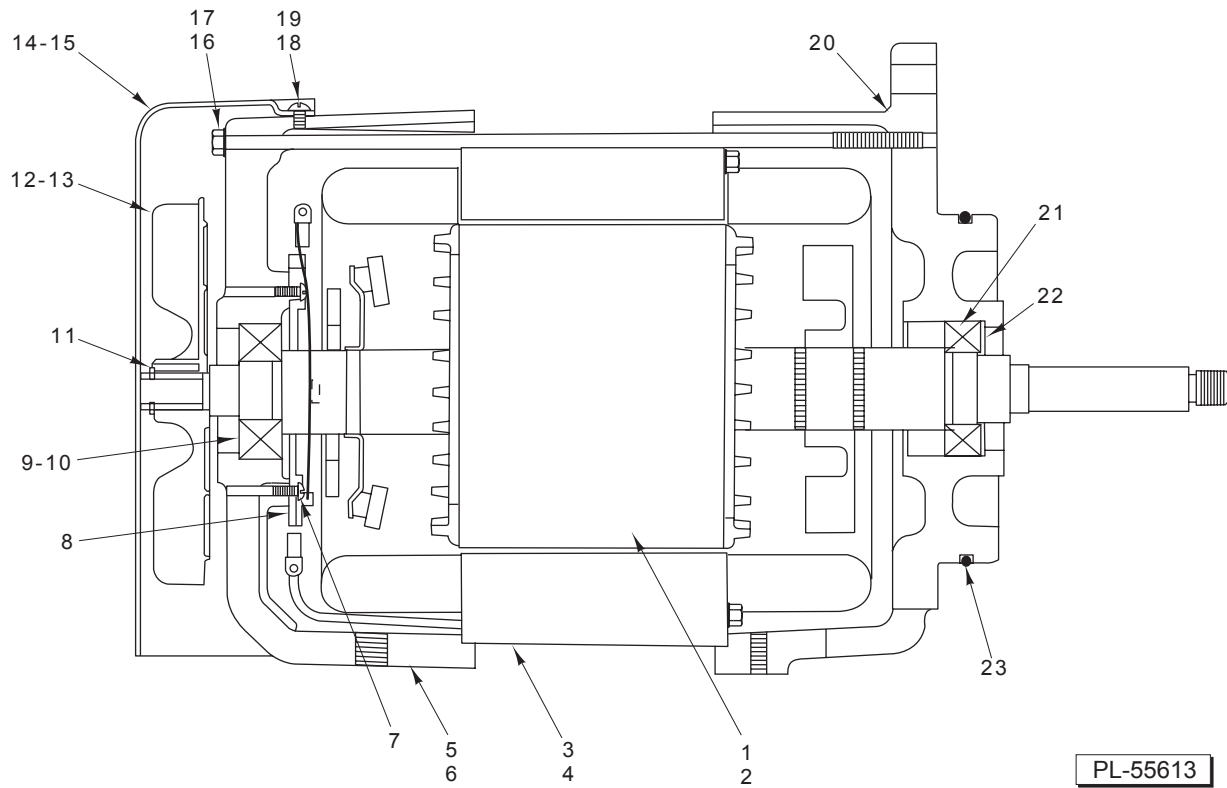

**MOTOR PARTS – 1 PHASE
(*NON GE MOTORS)**

ILLUS.	PART NO.	NAME OF PART	AMT.
	PL-55613		
1	00-022275-00276	Rotor Assy. (ML-104483)	1
2	00-022275-00277	Rotor Assy. (ML-104484) (Not Shown)	1
3	00-065477-162-1	Stator Assy. (120/240 V., 60 Hz.)	1
4	00-065477-162-2	Stator Assy. (208 V., 60 Hz.)	1
5	00-435867-00003	Housing – Motor (Rear) (ML-104484)	1
6	00-435867-00002	Housing – Motor (Rear) (ML-104483)	1
7	SC-009-49	Mach. Screw 6-32 x 3/8 Slotted Rd. Hd.	2
8	00-121110	Switch – Starting (Stationary Part) (1 Ph.)	1
9	BB-017-39	Ball Bearing (MRC SZZ-01-ST-A-92-C) (ML-104484)	1
10	BB-005-34	Ball Bearing (MRC 204 SZZ-01-ST-E-92-C) (ML-104483)	1
11	RR-011-05	Retaining Ring	1
12	00-274646-00002	Fan – Ventilating (ML-104484)	1
13	00-292466-00001	Fan – Ventilating (ML-104483)	1
14	00-435868	Shroud – Motor (ML-104483)	1
15	00-435869	Shroud – Motor (ML-104484) (Not Shown)	1
16	00-271335-00001	Bolt – Motor (1-Phase)	4
17	WL-003-22	Lockwasher #8	4
18	SC-018-34	Mach. Screw 8-32 x 1/2 Phil. Pan Hd.	3
19	WL-003-12	Lockwasher #8 Medium	3
**20	00-873505-00002	Housing – Motor (Front) (Not Shown)	1
21	BB-015-08	Ball Bearing (MRC 105KSZZ-01-ST-A-92-C)	1
22	SL-005-04	Spring – Loading	2
23	OR-001-01	O-Ring	1
	00-275152	Shim	AR
	00-435256-00003	Motor (120/240 V., 60 Hz.) (ML-104484)	1
	00-435256-00004	Motor (208 V., 60 Hz.) (ML-104484)	1

*For GE Motors, See Page 23.
**Also Order 67500-126 and See TSB 843E.

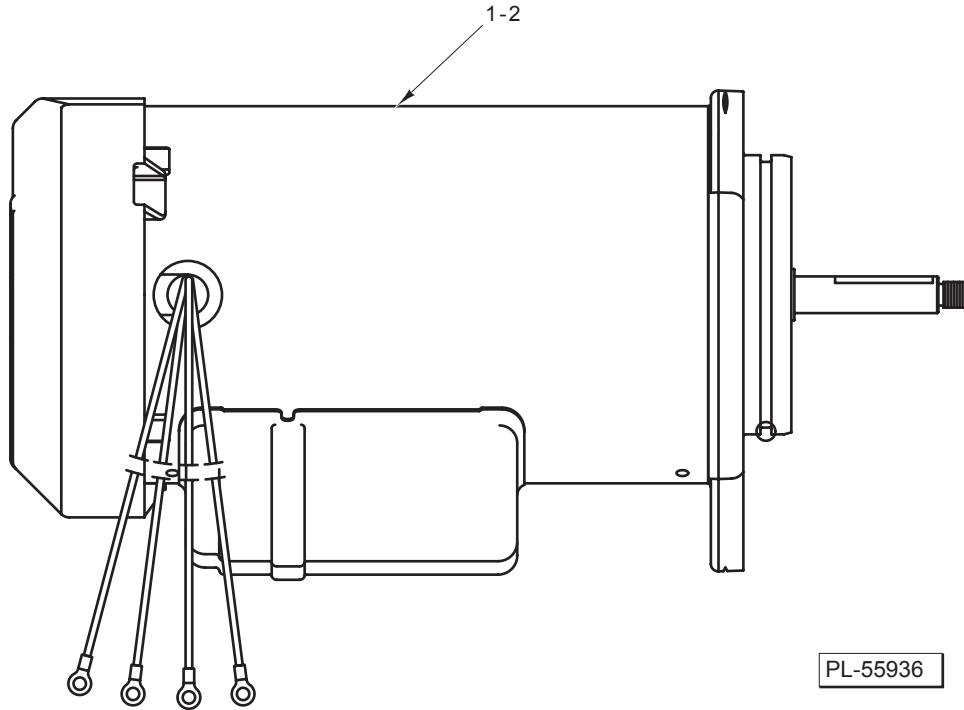

**MOTOR PARTS – 1 PHASE
(GENERAL ELECTRIC)**

ILLUS.	PART NO.	NAME OF PART	AMT.
PL-55936			
1	00-875334-00003	Motor (208 V., 60 Hz.) (ML-104483-BH Starting Serial No. 31-1260-524, 4/20/02) (ML-134185, ML-134188, ML-134254, & ML-134257)	1
2	00-875334-00004	Motor (120/240 V., 60 Hz.) (ML-104483, ML-134185, & ML-134254)	1

MODEL D340 MIXER REPLACEMENT PARTS

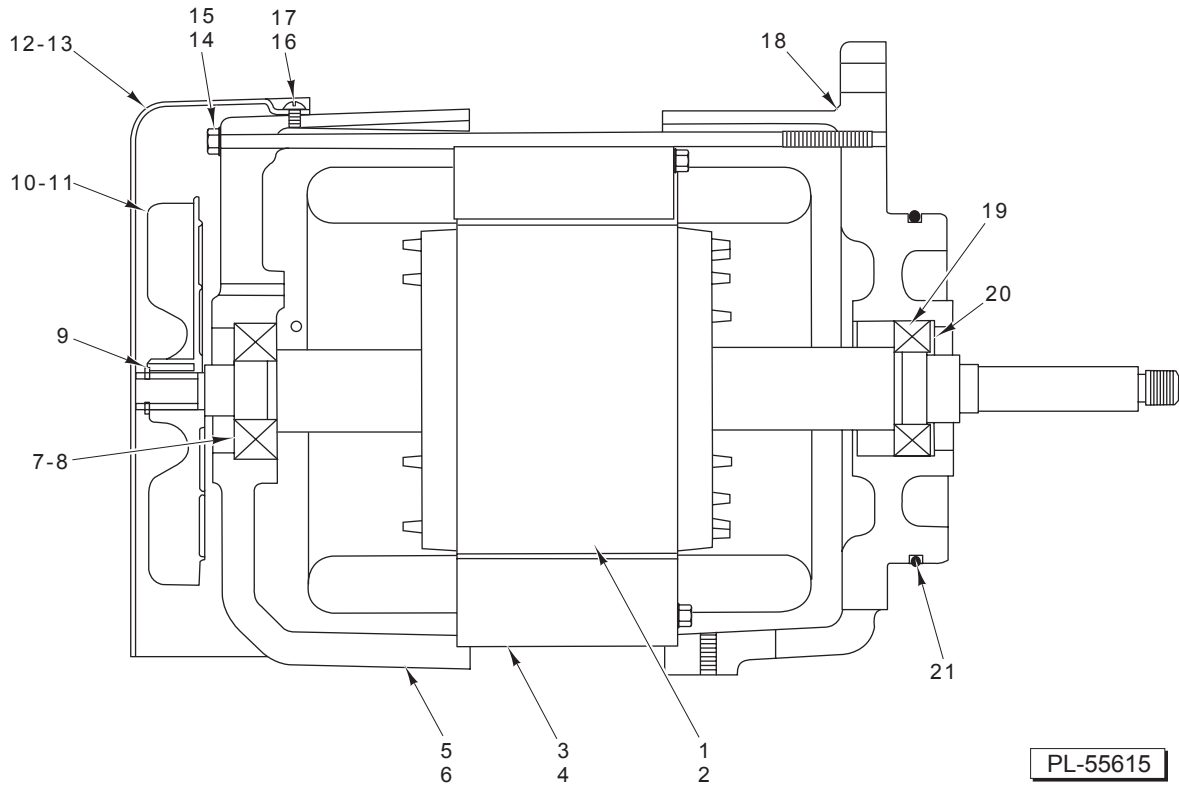

**MOTOR PARTS – 3 PHASE
(*NON GE MOTORS)**

ILLUS.	PART NO.	NAME OF PART	AMT.
PL-55615			
1	00-015747-00312	Rotor Assy. (ML-104483)	1
2	00-015747-00313	Rotor Assy. (ML-104484) (Not Shown)	1
3	00-065478-184-1	Stator Assy. (208 V., 60 Hz.)	1
4	00-065478-184-2	Stator Assy. (240/480 V., 60 Hz.)	1
5	00-435867-00002	Housing – Motor (Rear) (ML-104483)	1
6	00-435867-00003	Housing – Motor (Rear) (ML-104484)	1
7	BB-005-34	Ball Bearing (MRC 204 SZZ-01-ST-E-92-C) (ML-104483)	1
8	BB-017-39	Ball Bearing (MRC 205 SZZ-01-ST-A-92-C) (ML-104484)	1
9	RR-011-05	Retaining Ring	1
10	00-292466-00001	Fan – Ventilating (ML-104483)	1
11	00-274646-00002	Fan – Ventilating (ML-104484)	1
12	00-435868	Shroud – Motor (ML-104483)	1
13	00-435869	Shroud – Motor (ML-104484) (Not Shown)	1
14	00-271335-00002	Bolt – Motor (3 Phase)	4
15	WL-003-22	Lockwasher #10 Light	4
16	SC-018-34	Mach. Screw 8-32 x 1/2 Phil. Pan Hd.	3
17	WL-003-12	Lockwasher #8 Medium	3
**18	00-873505-00002	Housing – Motor (Front) (Not Shown)	1
19	BB-015-08	Ball Bearing (MRC 105KSZZ-01-ST-A-92-C)	1
20	SL-005-04	Spring – Loading	2
21	OR-001-01	O-Ring	1
	00-275152	Shim	AR
	00-435255-00003	Motor (208 V., 60 Hz.) (ML-104484)	1
	00-435255-00004	Motor (240/480 V., 60 Hz.) (ML-104484)	1

*For GE Motors, See Page 25.
**Also Order 67500-126 and See TSB 843E.

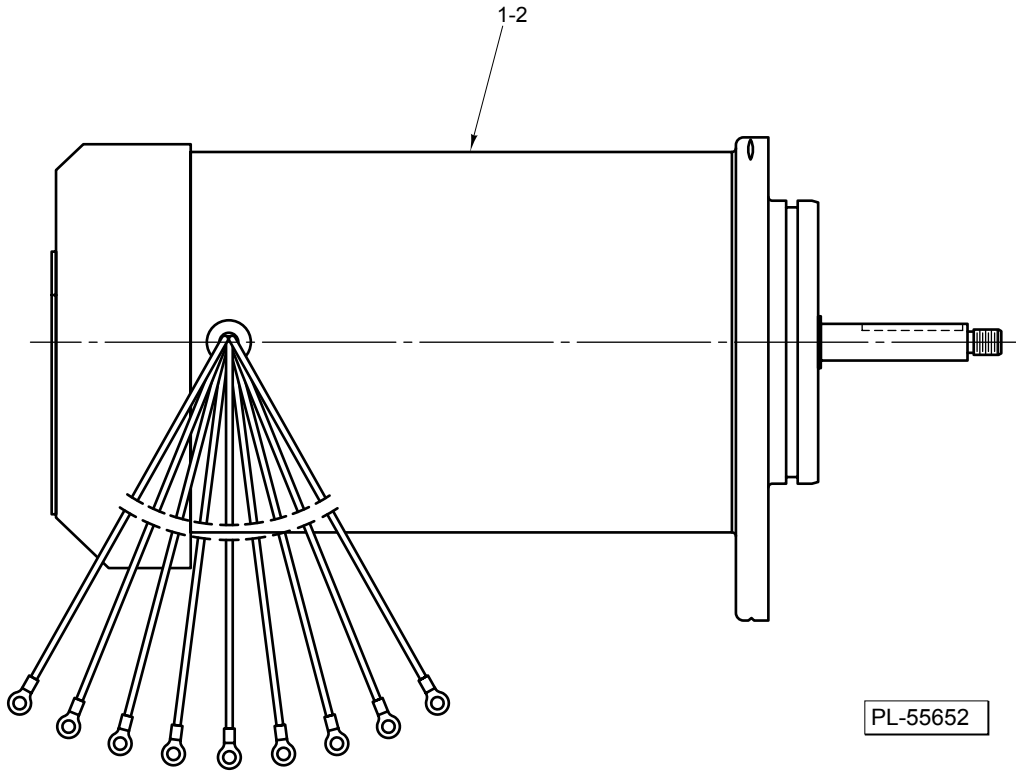

**MOTOR PARTS – 3 PHASE
(GENERAL ELECTRIC)**

ILLUS.	PART NO.	NAME OF PART	AMT.
PL-55652			
1	00-875334-00001	Motor (208 V., 60 Hz.) (ML-104483 Starting Serial No. 31-1240-016, 7/16/2001) (ML-134185, ML-134188, ML-134254, & ML-134257)	1
2	00-875334-00002	Motor (240 & 480 V., 60 Hz.) (ML-104483 Starting Serial No. 31-1240-016, 7/16/2001) (ML-134185 & ML-134254)	1

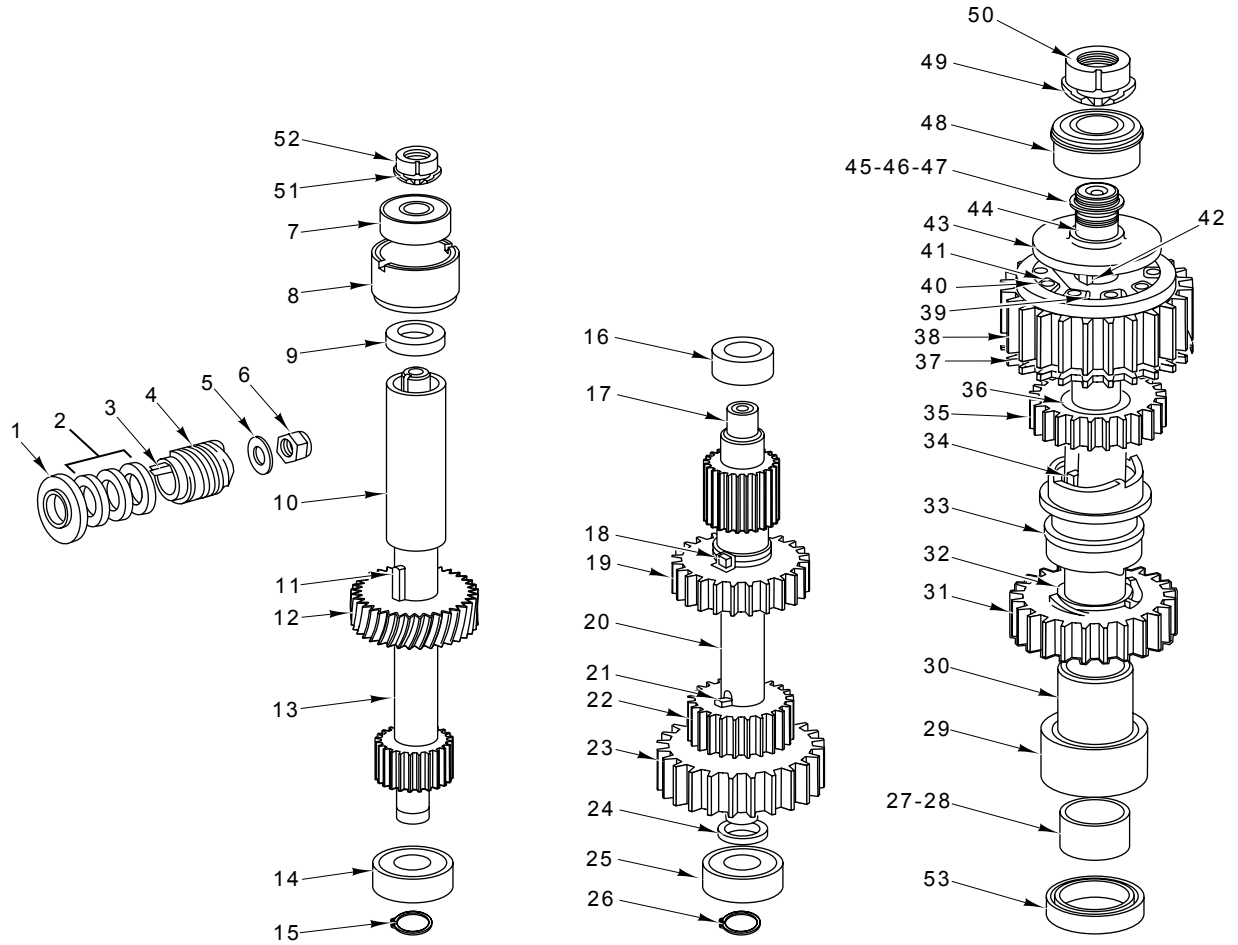

PL-55614

TRANSMISSION

TRANSMISSION

ILLUS. PL-55614	PART NO.	NAME OF PART	AMT.
1	00-271253	Deflector – Grease	1
2	00-077840	Washer – Belleville	6
3	00-012430-00069	Key ³ / ₁₆ Sq. x 1 ³⁹ / ₆₄ Lg.	1
4	00-271243	Worm (5T) (60 Hz.)	1
5	WS-021-01	Washer (SST)	1
6	NS-047-99	Lock Nut ⁷ / ₁₆ -20	1
7	BB-021-21	Ball Bearing (SKF-6203-2Z-NR-C3-UE)	1
8	00-271301	Sleeve – Worm Gear	1
9	00-271281	Spacer (Top of Worm Gear)	1
10	00-271280	Spacer (Worm Gear)	1
11	00-012430-00151	Key ¹ / ₂ Sq. x 1 ³ / ₁₆ Lg.	1
12	00-271244	Gear – Worm (29T) (60 Hz.)	1
13	00-271242	Shaft – Worm Gear	1
14	BB-020-06	Ball Bearing (Fafnir 204K DFA51580)	1
15	RR-004-07	Retaining Ring	1
16	BB-005-46	Ball Bearing (Fafnir 204K DDFS50545)	1
17	00-271238	Shaft – Transmission	1
18	00-012430-00138	Key ¹ / ₄ Sq. x ³ / ₄ Lg.	1
19	00-271239	Gear (36T)	1
20	00-271282	Spacer	1
21	00-012430-00152	Key ¹ / ₄ Sq. x ¹³ / ₁₆ Lg.	1
22	00-271240	Gear (27T)	1
23	00-271241	Gear (44T)	1
24	00-271283	Spacer – Lower Center Shaft	1
25	BB-020-06	Ball Bearing (Fafnir 204K DFA51580)	1
26	RR-004-07	Retaining Ring	1
27	00-067500-00070	O-Ring	1
28	00-437599	Seal – Hub	1
29	BB-015-36	Ball Bearing – Hoover (NSK 6007 DDUCE1 SRIS)	1
30	00-271278	Spacer – Lower Planetary Shaft	1
31	00-271237	Gear – Lower Clutch (46T)	1
32	00-271287	Bearing – Lower Clutch Gear	1
33	00-271226-00002	Sleeve – Clutch	1
34	00-012430-00182	Key ¹ / ₄ Sq. x 2 Lg.	2
35	00-271236	Gear – Upper Clutch (33T)	1
36	00-271285	Bearing – Upper Clutch Drive	1
37	00-271234-00002	Gear – Bevel (45T) (Also Order 271324-02)	1
38	00-271233	Gear – Roller Clutch (55T)	1
39	00-271289	Spring – Roller	10
40	00-271288	Roller – Clutch	10
41	00-271279	Sleeve – Drive	1
42	00-109070-00028	Key	1
43	00-271286	Spacer – Planetary Shaft	1
44	00-271229	Planetary Shaft	1
45	WS-030-25	Washer (0.002 Thk.)	AR
46	WS-030-26	Washer (0.003 Thk.)	AR
47	WS-030-27	Washer (0.010 Thk.)	AR
48	BB-021-22	Ball Bearing (SKF 5205A2ZNR3)	1
49	WL-012-06	Lockwasher N.D. #W-05	1
50	NS-034-06	Lock Nut Bearing N.D. #N-05	1
51	WL-012-04	Lockwasher N.D. #W-03	1
52	NS-034-04	Lock Nut N.D. #N-03	1
53	00-271341	Seal – Planetary Shaft	1
	00-437603	Planetary Shaft & Gear Assy. (Incls. Items 27 thru 32 & 44)	1
	00-274039	Center Shaft Assy. (Incls. Items 16 thru 26)	1

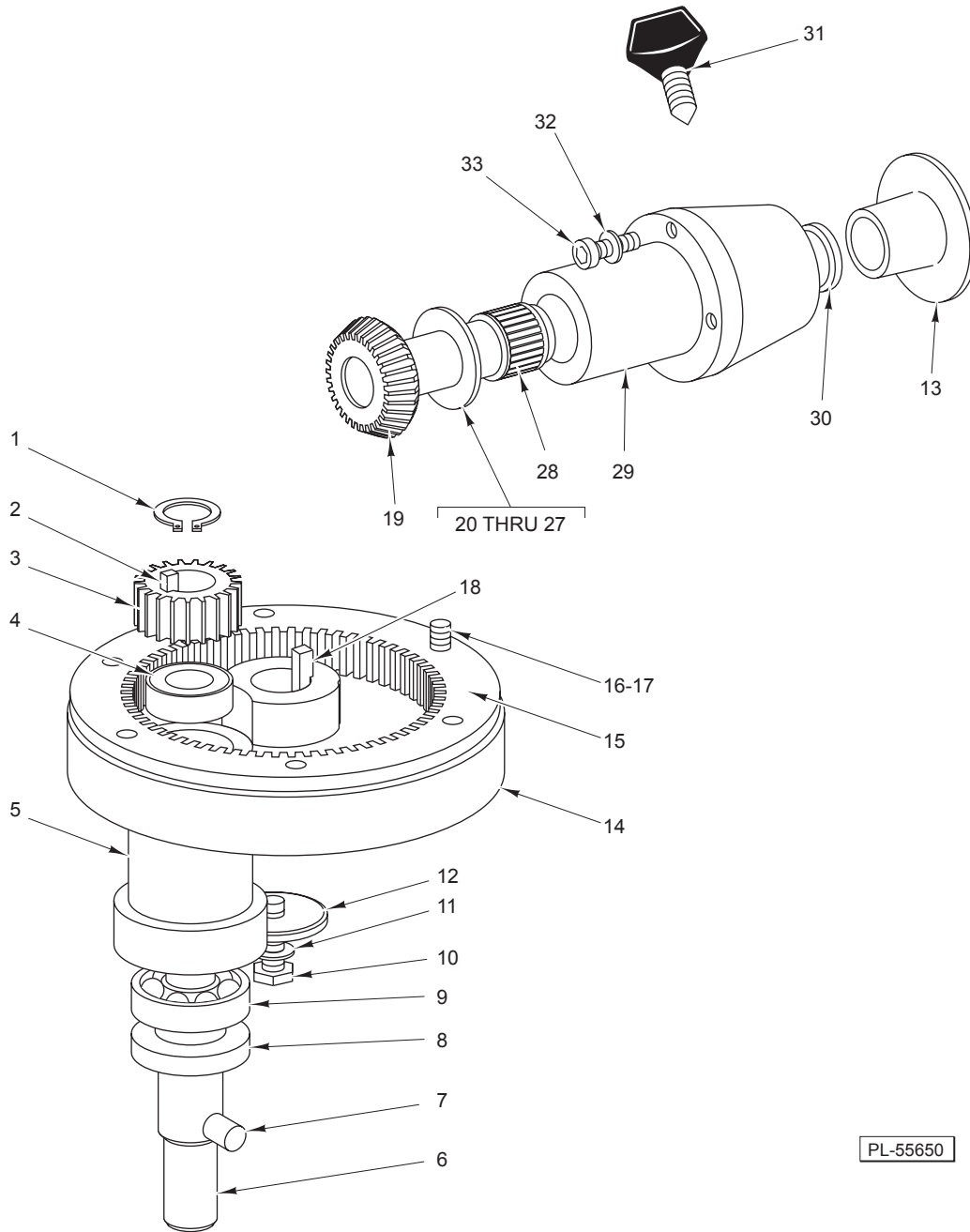

PL-55650

PLANETARY AND ATTACHMENT HUB

PLANETARY AND ATTACHMENT HUB

ILLUS. PL-55650	PART NO.	NAME OF PART	AMT.
1	RR-009-19	Retaining Ring	1
2	00-012430-00180	Key 1/4 Sq. x 1 3/16 Lg.	1
3	00-435548	Pinion – Agitator Shaft (18T)	1
*4	BB-021-34	Ball Bearing	1
*5	00-438240-00002	Planetary (Painted)	1
*6	00-438229	Agitator Shaft Assy. (Incls. Item 7)	1
7	00-070019	Pin – Agitator	1
*8	00-439286	Seal – Agitator Shaft	1
*9	BB-021-35	Ball Bearing	1
10	SC-062-58	Cap Screw 3/8-24 x 1 1/4 Hex Hd.	1
11	WL-006-27	Lockwasher 3/8 Light (SST)	1
12	00-070047-00001	Washer – Planetary	1
13	00-114824-00001	Plug – Attachment Hub	1
14	00-874984	Cup – Planetary Drip	1
*15	00-439291-00002	Gear – Internal (59T)	1
16	SC-089-19	Cap Screw 5/16-18 x 1 3/8 Soc. Hex Hd.	6
17	WL-003-48	Lockwasher 5/16 High Collar	6
18	00-012430-00173	Key 1/4 Sq. x 2 1/4 Lg.	1
19	00-271324-00002	Attachment Drive Gear (34T) & Expansion Plug Assy. (Also Order 271234-2)	1
20	00-070045-00002	Washer – Thrust (0.119 Thk.)	AR
21	00-070045-00003	Washer – Thrust (0.121 Thk.)	AR
22	00-070045-00004	Washer – Thrust (0.123 Thk.)	AR
23	00-070045-00005	Washer – Thrust (0.127 Thk.)	AR
24	00-070045-00001	Washer – Thrust (0.125 Thk.)	AR
25	00-070045-00006	Washer – Thrust (0.129 Thk.)	AR
26	BN-005-09	Needle Bearing (Torrington TRB 1828)	1
27	BN-005-10	Needle Bearing (Torrington NTA-1828)	1
28	BN-002-12	Needle Bearing	2
29	00-070511-00003	Attachment Hub & Bearing Assy. (Incls. Item 28)	1
30	00-070090	Seal – Attachment Hub	1
31	00-108197-00001	Thumb Screw	1
32	WL-003-43	Lockwasher 5/16 Light	3
33	SC-040-50	Cap Screw 5/16-18 x 2 1/4 Soc. Hex Hd.	3
*	00-438230	Planetary Assy. (Incls. Items 1 thru 6, 8, & 9)	1

*See TSB 787B.

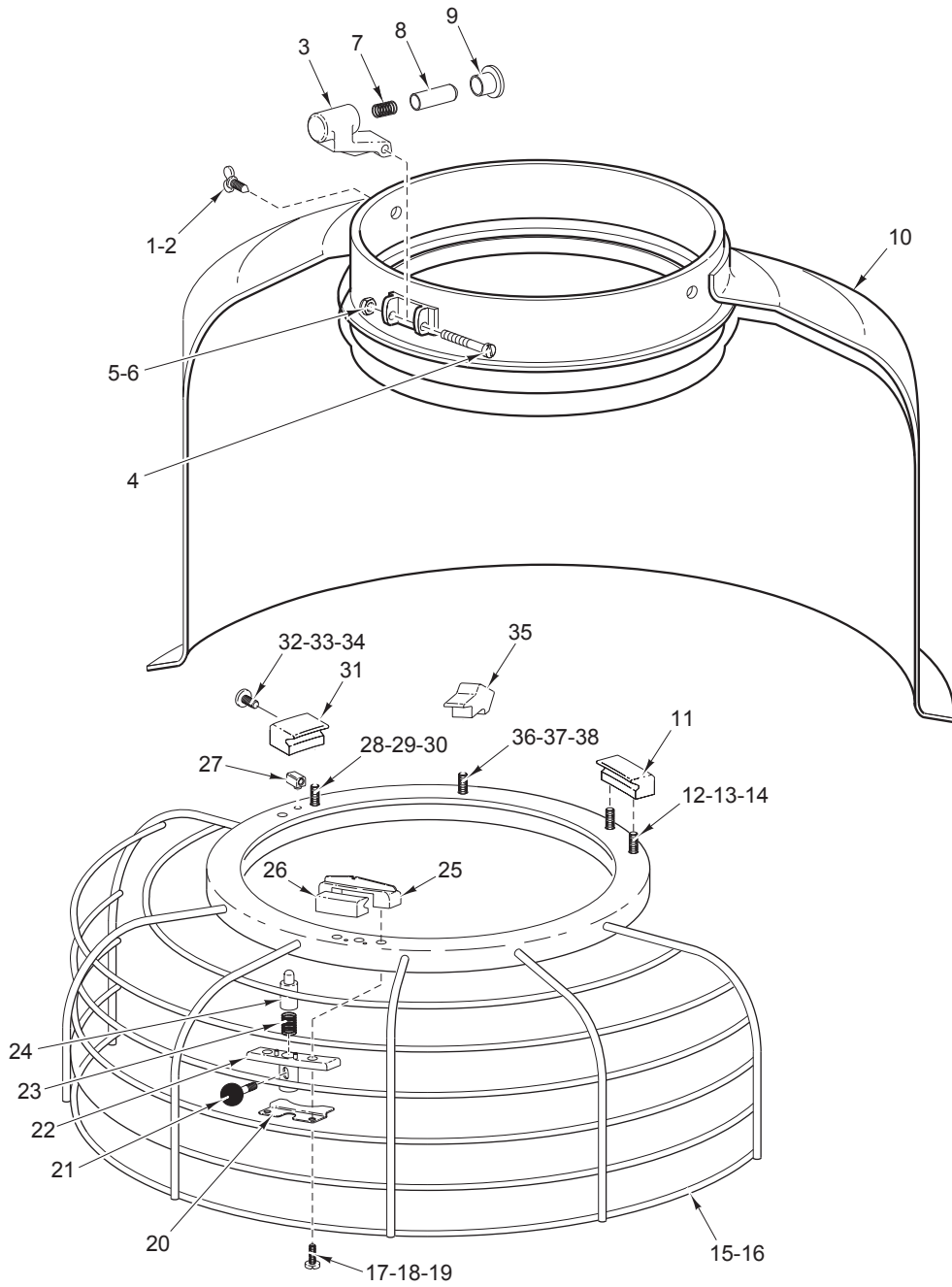

PL-55777

**BOWL GUARD UNIT
(PREVIOUS CONSTRUCTION)**

**BOWL GUARD UNIT
(PREVIOUS CONSTRUCTION)**

ILLUS.	PART NO.	NAME OF PART	AMT.
PL-55777			
1	00-070641-00011	Thumb Screw 8-32 Special	3
2	SC-121-91	Mach. Screw 8-32 x 1/4 Hex Button Hd., (SST) (ML-134188 & ML-134118)	3
3	00-479007	Latch – Catch Detent (Incls. Items 7, 8, & 9)	1
4	00-478602	Screw – Shoulder (ML-104483, ML-104484, & ML-134185) (See TSB 1039)	1
5	NS-011-07	Mach. Nut 6-32 (SST) Hex (ML-134118 & ML-134188) (Not Shown)	1
6	NS-031-50	Nut – Stop Special 6-32 (SST) (See TSB 1039)	1
7	00-437446-00001	Spring – Cage Detent	1
8	00-437724	Plunger – Detent	1
9	00-437725	Bushing – Detent	1
10	00-874963	Bullguard Upgrade kit - Includes Cage Assy and Splash Guard.....	1
11	00-437713	Shoe – Fixed	1
12	SC-122-52	Mach. Screw 1/4-20 x 3/8 Hex Button Hd. (SST) (ML-134118 & ML-134188)	2
13	00-512987	Loctite 222 Size 31 (50 cc) (ML-134118 & ML-134188)	1
14	SC-122-45	Mach. Screw 1/4-20 x 3/8 Slotted Truss Hd. (SST) (ML-104483, ML-104484, & ML-134185) ...	2
15	00-874956-00001	Wire Cage (ML-104483 & ML-104484)	1
16	00-874956-00002	Wire Cage (ML-134118)	1
17	SC-122-46	Mach. Screw 1/4-20 x 3/4 Slotted Truss Hd. (SST) (ML-104483, ML-104484, & ML-134185) ...	2
18	SC-122-68	Mach. Screw 1/4-20 x 3/4 Hex Button Hd. (SST) (ML-134118 & ML-134188)	2
19	00-512987	Loctite 222 Size 31 (50 cc) (ML-134118 & ML-134188)	1
20	00-437817	Stop – Cage	1
21	00-437436	Pin – Plunger	1
22	00-437447	Housing – Plunger Assy.	1
23	00-437446-00002	Spring – Cage On/Off	1
24	00-437432	Plunger	1
25	00-437718-00002	Saddle – Shoe	1
26	00-437715	Shoe – Saddle	1
27	00-437720	Key – Shoe	1
28	SC-122-45	Mach. Screw 1/4-20 x 3/8 Slotted Truss Hd. (SST) (ML-104483, ML-104484, & ML-134185) ...	2
29	SC-122-52	Mach. Screw 1/4-20 x 3/8 Hex Button Hd. (SST) (ML-134118 & ML-134188)	2
30	00-512987	Loctite 222 Size 31 (50 cc) (ML-134118 & ML-134188)	1
31	00-437714	Shoe – Adjustable	1
32	SC-123-07	Mach. Screw Special 8-32 x 1/2 Slotted Truss Hd. (SST) (ML-104483, ML-104484, & ML-134185)	1
33	SC-122-76	Mach. Screw Special 8-32 x 1/2 Hex Button Hd. (SST) (ML-134118 & ML-134188)	1
34	00-512987	Loctite 222 Size 31 (50 cc) (ML-134118 & ML-134188)	1
35	00-437805	Retainer – Magnet	1
36	SC-122-44	Mach. Screw 8-32 x 3/8 Slotted Truss Hd. (SST) (ML-104483, ML-104484, & ML-134185)	1
37	SC-121-92	Mach. Screw 8-32 x 3/8 Hex Button Hd. (SST) (ML-134118 & ML-134188)	1
38	00-512987	Loctite 222 Size 31 (50 cc) (ML-134118 & ML-134188)	1
	00-439096	Ingredient Chute	1

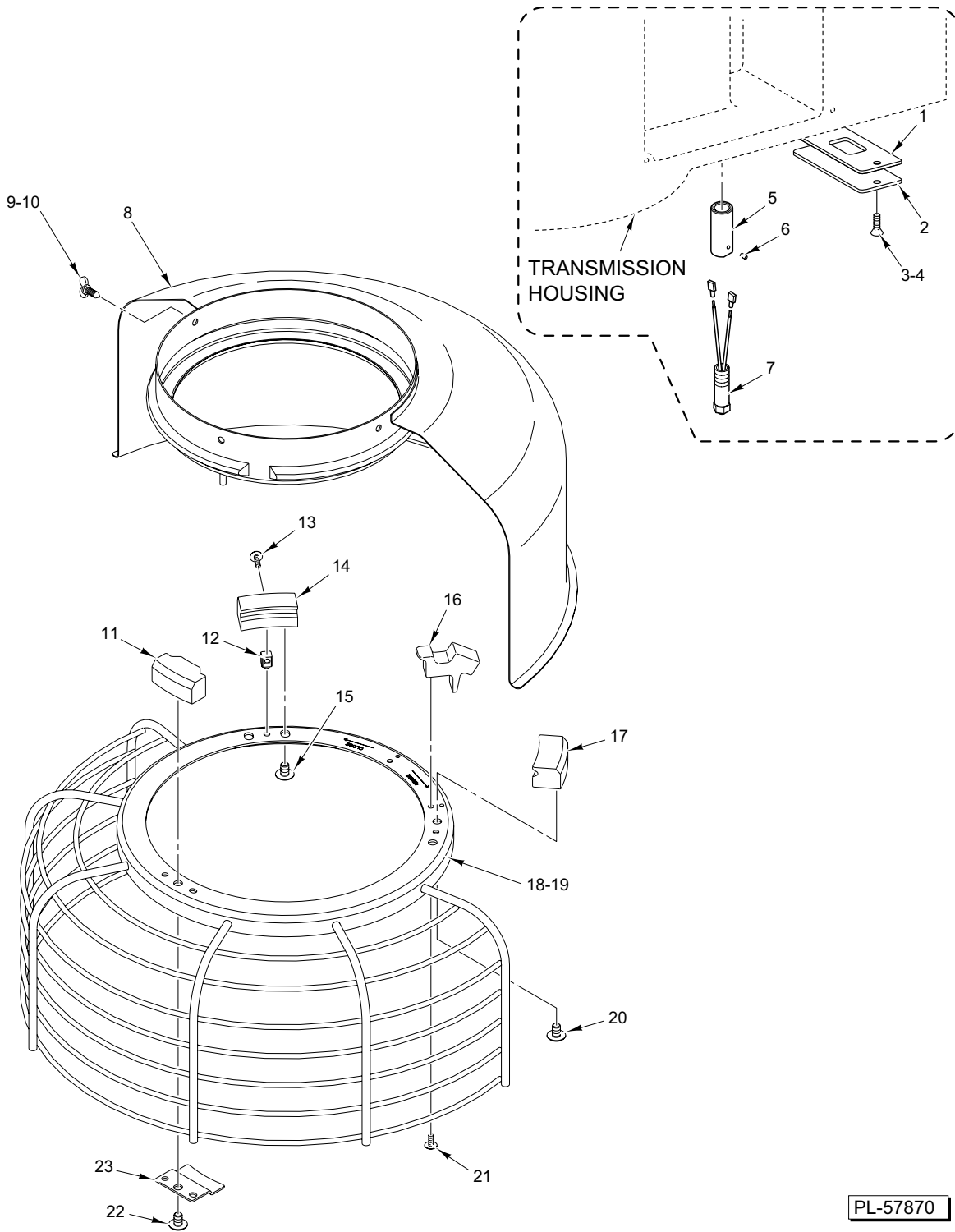

**BOWL GUARD UNIT
(CURRENT CONSTRUCTION)**

**BOWL GUARD UNIT
(CURRENT CONSTRUCTION)**

ILLUS. PL-57870	PART NO.	NAME OF PART	AMT.
1	00-437809	Gasket – Reed Housing	1
2	00-874974	Plate – Transmission Cover	1
3	SC-022-22	Mach. Screw 10-24 x 3/4 Slotted Pan Hd. (SST)	2
4	SC-122-77	Mach. Screw 10-24 x 3/4 Tx. Flat Hd. (SST)	2
5	00-874990	Extension – Bowl Guard Switch	1
6	SC-075-14	Set Screw 6-32 x 1/8 Hex Hdls., Cup Pt.	1
7	00-874958-00001	Reed – Switch & Plug	1
8	00-874981	Guard – Splash.....	1
9	00-070641-00011	Thumb Screw 8-32 Special (ML-134254)	3
10	SC-128-73	Mach. Screw 8-23 x 1/4 Tx. Button Hd. (SST) (ML-134257)	3
11	00-874983	Shoe – Front	1
12	00-437720	Key – Shoe	1
13	SC-123-07	Mach. Screw 8-23 x 1/2 Slotted Truss Hd.	1
14	00-437714	Shoe – Adjustable	1
15	SC-122-45	Mach. Screw 1/4-20 x 3/8 Slotted Truss Hd.	2
16	00-437805	Retainer – Magnet (Incls. Magnet)	1
17	00-437713	Shoe – Fixed	1
18	00-874978-00001	Wire Cage (ML-134254)	1
19	00-874978-00002	Wire Cage (ML-134257)	1
20	SC-122-45	Mach. Screw 1/4-20 x 3/8 Slotted Truss Hd.	2
21	SC-122-44	Mach. Screw 8-23 x 3/8 Slotted Truss Hd.	1
22	SC-122-45	Mach. Screw 1/4-20 x 3/8 Slotted Truss Hd.	1
23	00-874980	Stop – Cage	1
	00-874977-00001	Wire Cage Assy. (Incls. Items 8, 9, 11 thru 18, & 20 thru 23) (ML-134254)	1
	00-874977-00002	Wire Cage Assy. (Incls. Items 8, 10 thru 17, & 19 thru 23) (ML-134257)	1

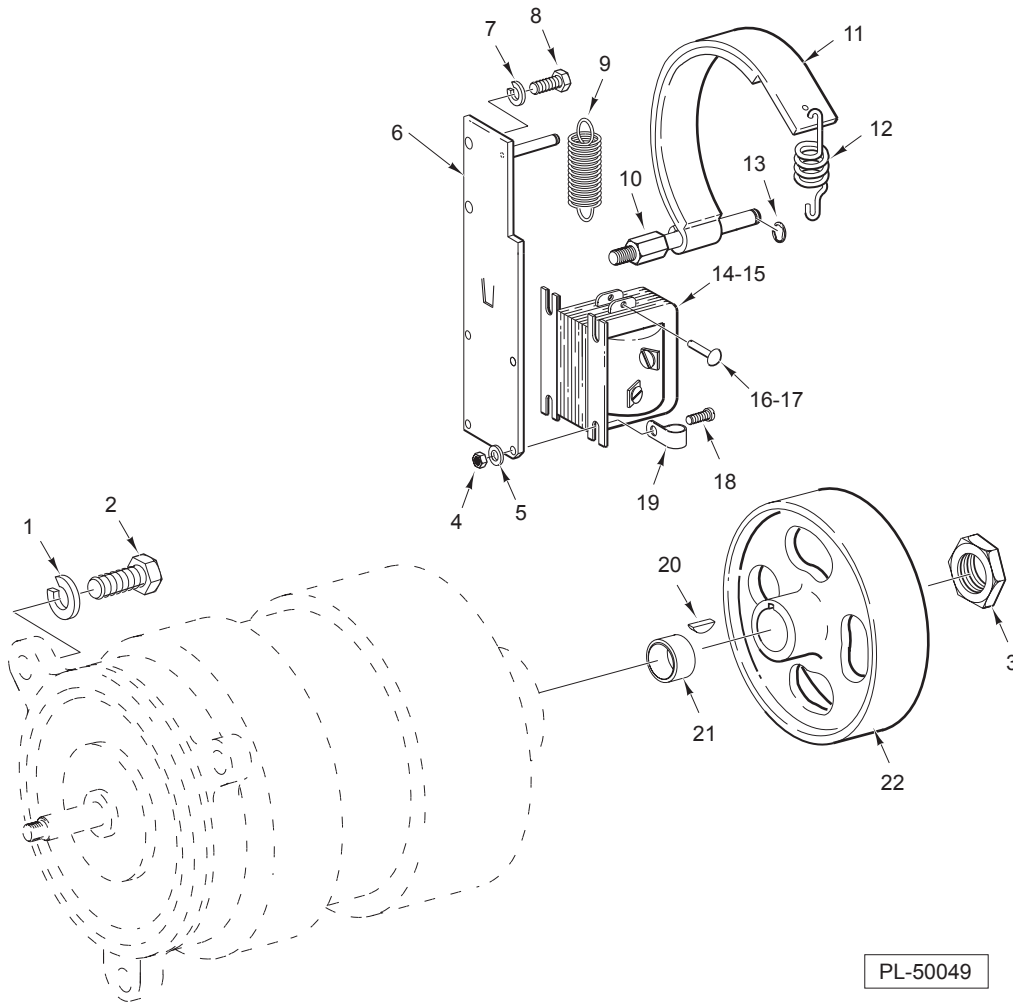

BRAKE UNIT

ILLUS.	PART NO.	NAME OF PART	AMT.
1	WL-004-06	Lockwasher $\frac{3}{8}$ Medium	3
2	SC-116-83	Cap Screw $\frac{3}{8}$ -16 x $1\frac{1}{2}$ Hex Hd.	3
3	00-006566	Lock Nut	2
4	NS-037-06	Lock Nut 8-32 Nylok	4
5	WS-019-10	Washer	4
6	00-435250	Plate – Solenoid	1
7	WL-006-16	Lockwasher $\frac{1}{4}$ Light	2
8	SC-110-12	Cap Screw $\frac{1}{4}$ -20 x $\frac{5}{8}$ Hex Hd.	2
9	00-271292	Spring – Brake	1
10	00-435247	Pivot – Brake Band	1
11	00-024776	Brake Band Assy.	1
12	00-024775	Spring – Motor Brake	1
13	RR-006-22	Retaining Ring	1
14	00-023926-00007	Solenoid – Brake (120 V.)	1
15	00-023926-00001	Solenoid – Brake (208/240 V.)	1
16	00-063201	Pin – Solenoid Clevis	1
17	PC-003-23	Cotter Pin $\frac{1}{16}$ x $\frac{1}{2}$	1
18	SC-009-61	Mach. Screw 8-32 x $\frac{1}{2}$ Slotted Rd. Hd.	4
19	00-024167-00001	Clamp – Lead Support	1
20	KW-003-05	Key – Woodruff #405	1
21	00-435251	Bushing – Brake Drum	1
22	00-060777	Brake Drum	1

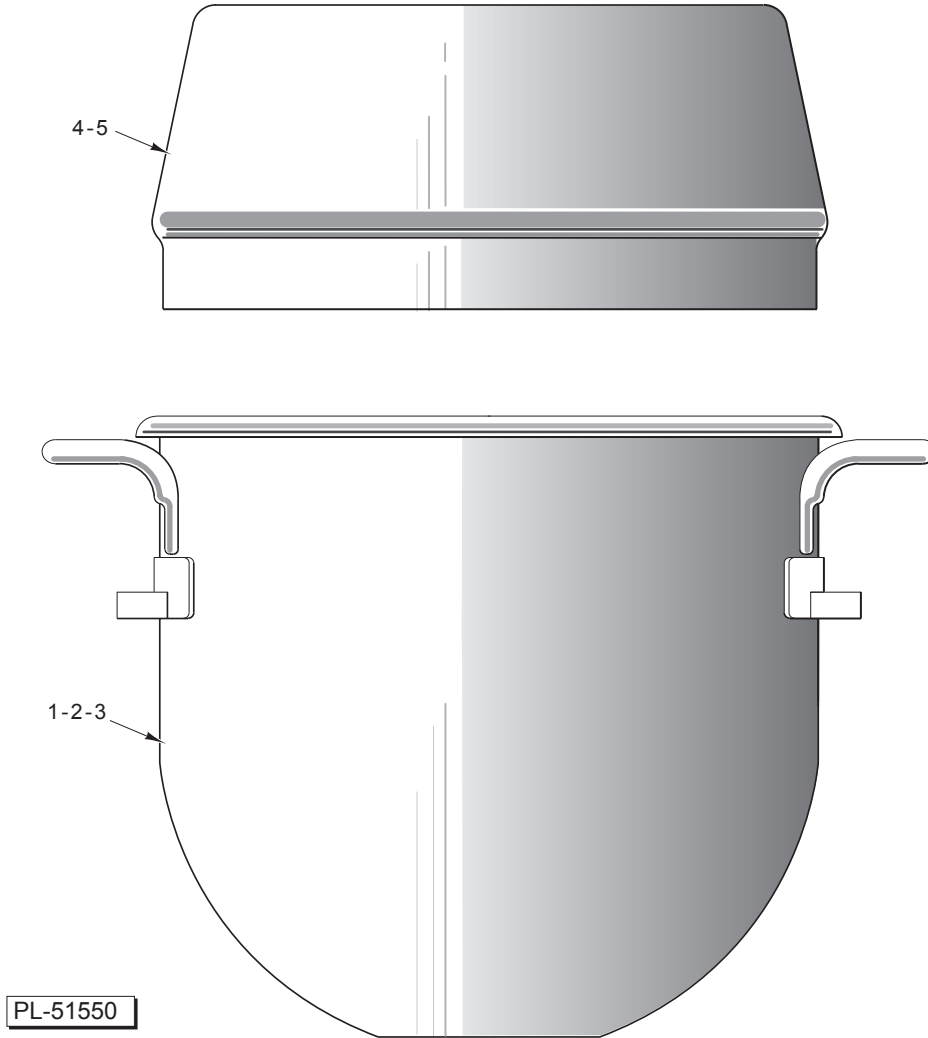

BOWL

ILLUS.	PART NO.	NAME OF PART	AMT.
1	00-437410	Bowl – 30 Qt. (SST)	1
2	00-295647	Bowl – 20 Qt. (SST)	1
3	00-315245	Bowl – 40 Qt. (SST)	1
4	00-438080	Splash Cover Assy. – 30 Qt.	1
5	00-438079	Splash Cover Assy. – 20 Qt.	1

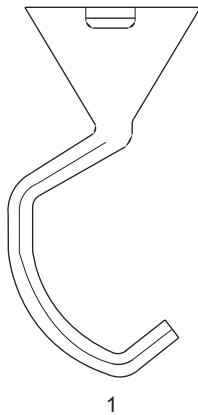

1

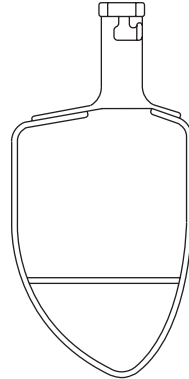

2

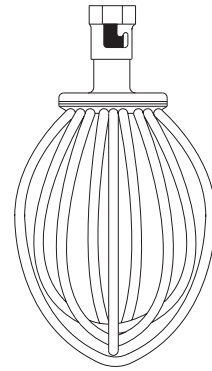

3

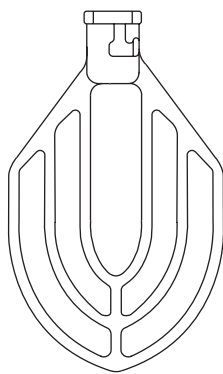

4-5

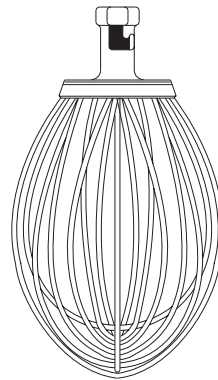

6

PL-55806

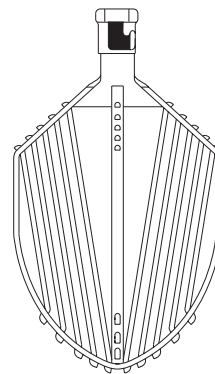

7

AGITATORS

ILLUS.	PART NO. 30/40 Qt.	PART NO. 20 Qt.	NAME OF PART	AMT.
1	00-295120	00-275465	"E" Dough Arm (Packaged)	1
2	00-295037	-	"P" Pastry Knife (Packaged)	1
3	00-295163	-	"I" Wire Whip (Deluxe) (Packaged)	1
4	00-275450	00-275461	"B" Flat Beater (Standard) (Packaged)	1
5	00-275451	00-275462	"B" Flat Beater (Deluxe) (Packaged)	1
6	00-275899	00-295029	"D" Wire Whip (Deluxe) (Packaged)	1
7	00-295161	-	"C" Wire Whip (Packaged)	1
	00-315556	-	"ED" Dough Arm – Spiral (Not Shown) (Deluxe) (Packaged)	1
	00-478596	-	"ED" Dough Arm – Spiral (Not Shown) (Standard) (Packaged)	1