



# **INSTRUCTION MANUAL**

## **... with Replacement Parts**



### **MODEL FD500**

### **FOOD WASTE DISPOSERS**

**(INCLUDES MOTOR PARTS)**  
**ML-18978**

# Installation, Operation, and Care of MODEL FD500 FOOD WASTE DISPOSER

SAVE THESE INSTRUCTIONS

## GENERAL

The FD500 disposer features removable hardened steel components and reversible rotation with grinding in both directions. The disposer is self-feeding, making it unnecessary to force the food waste into the grinding mechanism.

The FD500 food waste disposer utilizes hardened steel cutter blocks (1, Fig.1) mounted to a rotating flywheel (4, Fig.1) and a stationary shredder ring (2, Fig. 1) to grind food waste to a small particle size for discharge through waste lines. With the motor running and flushing water turned on, food waste is reduced to grinding size by the rotating "hi-bulk" cutter (3, Fig. 1). Grinding occurs as the food waste is forced against the shredder ring by the cutter blocks and the centrifugal force due to rotation. The flushing water aids the grinding action and discharges ground food waste into the waste line.

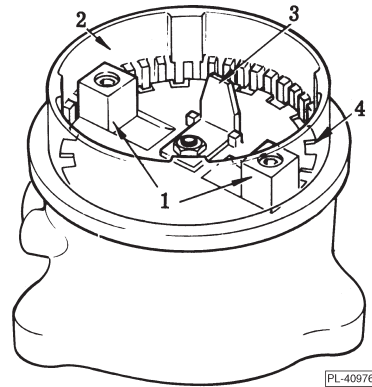

Fig. 1

Control groups and accessory groups are available to suit each installation.

## INSTALLATION

Immediately after unpacking the disposer, check for possible shipping damage. If the disposer is found to be damaged, save the packaging material and contact the carrier within 15 days of delivery.

Prior to installation, test the electrical service to make sure that it agrees with the specifications on the disposer data plate.

Use legs and temporary blocking to support the disposer during installation to avoid excessive stress at welded or soldered cone to table connection.

### ASSEMBLY

To attach the disposer assembly to the cone, see Figs. 2 and 4. Remove the ten screws holding the clamp ring halves in place and remove the clamp ring halves. Raise the disposer into position using the adjustable legs to bring the disposer into firm contact with the cone flange. Do not place the weight of the disposer on the cone.

Turn each adjustable foot as required to complete height and level adjustments.

Assemble the clamp ring halves using the ten screws and tighten screws finger tight. Rotate disposer to the desired position. Tighten the ten screws evenly to form a water tight joint.

For an accessory group D installation, use the mounting flange (1, Fig. 3) included with accessory group D. See Fig. 3 and the accessory group data sheet.

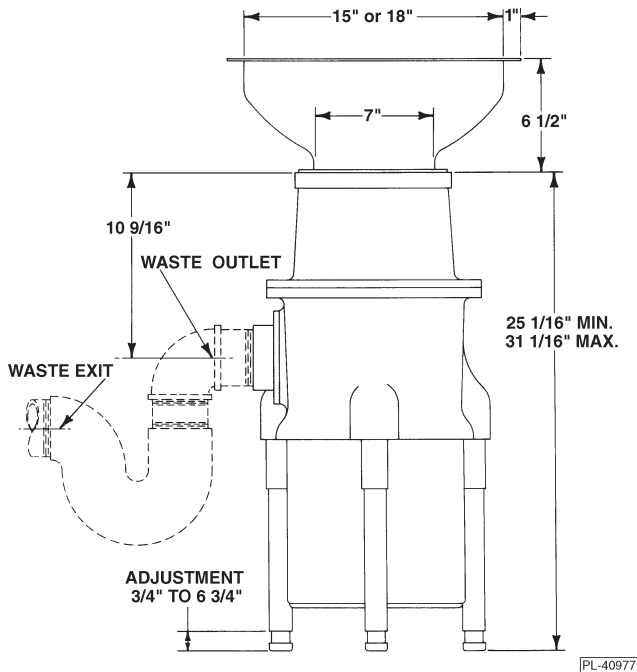

Fig. 2

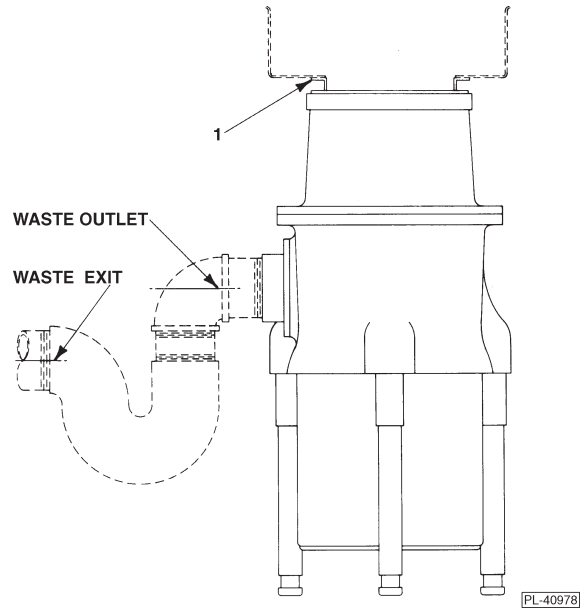

Fig. 3

**WARNING: HAZARDOUS MOVING PARTS — DO NOT OPERATE DISPOSER UNTIL PROPERLY INSTALLED TO CONE.**

Use one of the following: Part No. 204006 or 204007 (15 inch diameter cone), Part No. 204003 or 204004 (18 inch diameter cone). For custom built installations — minimum thickness of stainless steel cone shall be .035 inches and minimum height of cone (vertical distance from work surface to disposer sink flange) shall be 7 inches (Fig. 4).

**PLUMBING**

**WARNING: PLUMBING CONNECTIONS MUST COMPLY WITH APPLICABLE SANITARY, SAFETY AND PLUMBING CODES.**

**Drain**

The disposer is furnished with a waste discharge outlet flange (7, Fig. 5) threaded with a standard 3" IPS tapered thread. Install waste lines with the shortest possible run and best fall. If possible, use a fall of 1/4" per foot. The waste exit must be lower than the waste outlet (Fig. 2). The waste lines must be thoroughly cleaned. Ream burrs from cut pipe ends and use fittings which will permit unrestricted flow. Drum traps and grease traps must NOT be used.

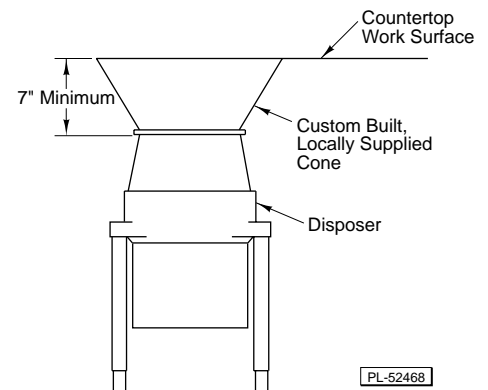

Fig. 4

## Water Connections

Connect disposer swirl (1, Fig. 5) from a  $\frac{3}{4}$ " IPS cold water supply line. Install the ten gallon per minute flow control supplied with the disposer (2, Fig. 5). If the water line pressure exceeds 60 psig, a pressure reducing valve (6, Fig. 5) (not supplied) should be installed. The minimum flow pressure for the disposer to function properly is 16 psig. Install a shut-off valve (not supplied) for proper servicing of the disposer.

Control Groups 2 and 3 are supplied with a solenoid valve (4, Fig. 5 or 2, Fig. 6) which must be installed in the water supply line as shown. Control Group 3 is furnished with a pressure switch (5, Fig. 5 or 3, Fig. 6) which must be installed between the solenoid valve and pressure reducing valve. If there is no pressure reducing valve in the water supply line, install the pressure switch between the solenoid and the shut-off valve.

Install a vacuum breaker (3, Fig. 5) according to the local plumbing codes. If local plumbing codes prohibit the use of a vacuum breaker, install an air gap water inlet (1, Fig. 6) (not supplied) observing the local codes.

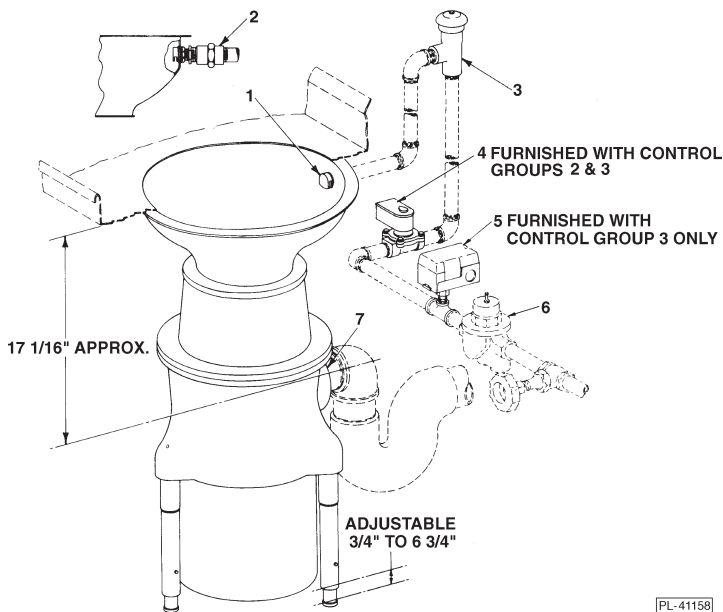

Fig. 5

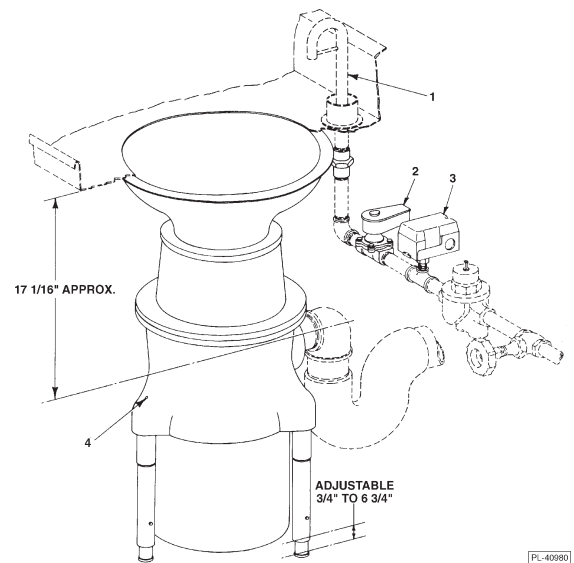

Fig. 6

## ELECTRICAL CONNECTIONS

**WARNING:** ELECTRICAL AND GROUNDING CONNECTIONS MUST COMPLY WITH THE APPLICABLE PORTIONS OF THE NATIONAL ELECTRICAL CODE AND/OR OTHER LOCAL ELECTRICAL CODES.

**WARNING:** DISCONNECT ELECTRICAL POWER SUPPLY AND PLACE A TAG AT THE DISCONNECT SWITCH INDICATING THAT YOU ARE WORKING ON THE CIRCUIT.

This unit must be connected to a dedicated, acceptable motor control switch with a marked OFF position to disconnect the appliance from all ungrounded supply conductors. The switch must be mounted within sight of the disposer or sink opening for the disposer.

Knockouts are provided in the motor junction box for making electrical connections to the unit. Flexible conduit should be used to permit moving the unit for periodic servicing and maintenance.

Select and follow wiring diagram, furnished with machine, applicable to your disposer and electrical service.

# OPERATION

Before operating disposer make sure it is clear of foreign objects such as metal or wire clippings, screws, nails, etc., which may have dropped into it during installation. Check the flywheel for free rotation.

**WARNING:** NEVER USE YOUR HAND TO CHECK ROTATION OF FLYWHEEL OR TO REMOVE FOREIGN MATTER FROM THE DISPOSER. USE A STICK OR SIMILAR OBJECT TO TURN THE FLYWHEEL. FOREIGN MATTER CAN BE REMOVED WITH TONGS OR PLIERS.

Start the disposer before feeding food waste. Be sure water is flowing. With typical optional controls, water flow and unit starting are simultaneous and automatic. Feed food waste into disposer. DO NOT feed china, metal, rags, clam shells, or similar material into the unit. DO NOT put grease or oil in the disposer. Oil or grease can clog the drain. Always allow the disposer to run for a short period after grinding is completed to assure proper flushing of the disposer and waste line. This flushing is automatically controlled with certain optional controls.

## CONTROLS

**WARNING:** NEVER REACH INSIDE THIS DISPOSER WHILE IT IS OPERATING.

The operation of the disposer and additional available controls will depend on the selection of control devices. Refer to control group data sheet.

## CLEANING

The food waste disposer should be kept in a clean and sanitary condition. Allow the disposer to run a few minutes after disposing of all food waste to completely flush out the interior. If food waste is allowed to accumulate due to improper clean-up, it will give off offensive odors. If this happens, cleaning can be accomplished by using a stiff brush with a strong soap and hot water solution. Light cleaning can be accomplished by grinding ice and a lemon through the disposer.

**CAUTION:** Do not use chemical solvents or other drain cleaning compounds through the disposer.

# MAINTENANCE

## LUBRICATION

No lubrication is required for the food waste disposer. Its grease-packed bearings require no service.

## CUTTER BLOCKS

The cutter blocks (1, Fig. 1) may be rotated by a qualified Hobart Service Technician if the cutting edges become worn.

## OVERLOAD PROTECTION

The disposer motor is protected by a thermal, resettable overload protector and will trip if the motor is overloaded. To reset, allow approximately five minutes for cooling, then press the manual reset button located on the bottom of the motor junction box. An arrow on the side of the motor junction box indicates location of the button. Restart the disposer using normal operating procedure. If overload protector continues to trip, contact your local Hobart Service Office.

## WATER SEAL VENT

A small weep hole (4, Fig. 6) in the side of the lower housing vents the dry side of the water seal. Water leaking from this weep hole is an indication of water seal leakage. If leaking, the water seal should be replaced. DO NOT plug or put grease in the weep hole.

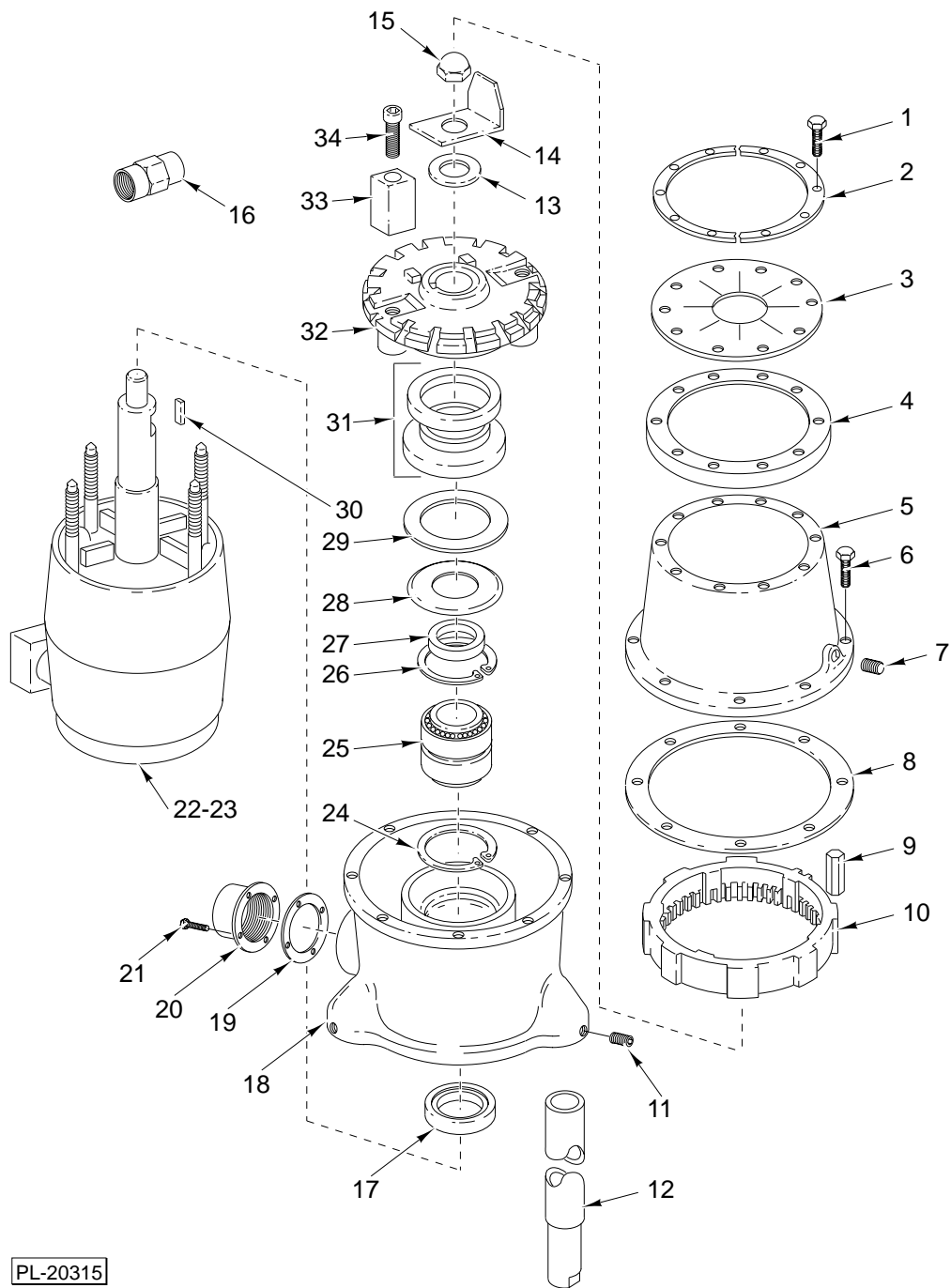

PL-20315

**DISPOSER UNIT**

## DISPOSER UNIT

ILLUS. PL-20315	PART NO.	NAME OF PART	AMT.
1	SC-041-12	Cap Screw $\frac{5}{16}$ -18 x $\frac{7}{8}$ Hex Hd. ....	10
2	00-203185	Ring - Top Cone Clamp (Half) .....	2
3	00-202105	Guard - Splash .....	1
4	00-201493	Ring - Isolating .....	1
5	00-200950-00002	Housing - Upper .....	1
6	SC-036-40	Cap Screw $\frac{5}{16}$ -18 x $1\frac{1}{4}$ Hex Hd. ....	8
7	FP-066-02	Plug $\frac{1}{2}$ Sq. Hd. Pipe .....	1
8	00-201415	Gasket - Waist .....	1
9	00-123421	Pin - Shredder lock .....	1
10	00-201231	Ring - Shredder .....	1
11	SC-088-36	Set Screw $\frac{5}{16}$ -18 x $\frac{1}{2}$ Hex Hdls. Cup Pt. ....	3
12	00-288380-00002	Leg Adjusting .....	3
13	00-272005	Washer - Sealing .....	1
14	00-201237	Cutter - Hi-Bulk .....	1
15	NS-031-45	Stop Nut $1\frac{1}{8}$ -12 Hex .....	1
16	00-204369-00001	Flow Control (10 G.P.M.) .....	1
17	00-201466	Seal-Oil .....	1
18	00-276070	Lower Housing Assy. ....	1
19	00-201414	Gasket .....	1
20	00-204850	Flange - Outlet .....	1
21	SC-041-12	Cap Screw $\frac{5}{16}$ -18 x $\frac{7}{8}$ Hex Hd. ....	4
22	00-475137-00009	Motor (60 Hz.) .....	1
23	00-121009-00002	Motor (50 Hz.) .....	1
24	RR-011-66	Retaining Ring .....	1
25	00-202920	Bearing .....	1
26	RR-011-66	Retaining Ring .....	1
27	00-202709	Spacer - Shaft .....	1
28	00-202729	Slinger - Water .....	1
29	00-118910	Support - Seal .....	1
30	00-203617	Key - Shaft .....	1
31	00-117072	Water Seal Assy. ....	1
32	00-201211	Flywheel .....	1
33	00-201223-00005	Cutter - Flywheel .....	2
34	00-202556-00003	Screw .....	2
	00-200435	Seal & Bearing Kit (Incls. items 13, 15, 17, 25, 27, 28 & 31) .....	1

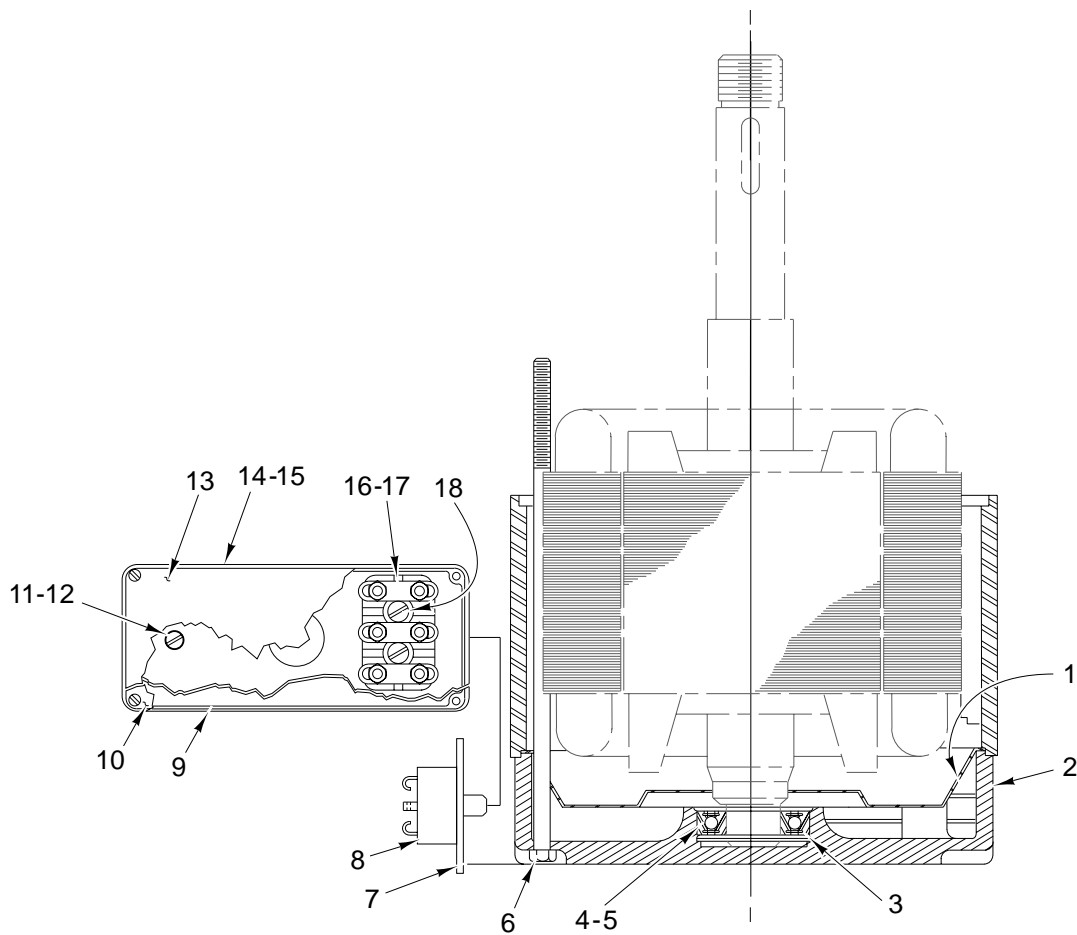

PL-53194

**MOTOR UNIT**

ILLUS. PL-53194	PART NO.	NAME OF PART	AMT.
	1	00-116744 Baffle .....	1
	2	00-120836 Bracket - Bearing .....	1
	3	SL-005-01 Spring - Loading - N.D. #52 Wavy .....	2
	4	BB-017-36 Ball Bearing SKF #6205Z (50 Hz Motor Unit) .....	1
	5	BB-008-33 Ball Bearing Fafnir 3205WD (60 Hz Motor Unit) .....	1
	6	00-120994 Bolt $\frac{5}{16}$ -18 x $8\frac{15}{16}$ .....	4
	7	00-116745-00001 Bracket - Protector (60 Hz Motor Unit) .....	1
	8	00-201982-00016 Protector (60 Hz Motor Unit) .....	1
	9	00-120990 Box - Conduit (60 Hz Motor Unit) .....	1
	10	00-120991 Cover - Conduit Box (60 Hz Motor Unit) .....	1
	11	00-202559 Screw - Grounding 10-32 x 3.8 Slotted Hex Hd. ....	1
	12	WC-004-10 Washer - Countersunk .....	1
	13	00-201152-00005 Cover - Conduit Box (50 Hz Motor Unit) .....	1
	14	00-117433 Box - Conduit (50 Hz Motor Unit) .....	1
	15	00-294028 Back - Plate .....	1
	16	00-270172 Terminal Block Assy. (50 Hz Motor Unit) .....	1
	17	00-116801 Spacer - Terminal Block (50 Hz Motor Unit) .....	1
	18	SC-060-39 Mach. Screw 6-32 x $\frac{7}{8}$ Rd. Hd. (50 Hz Motor Unit) .....	2
		00-270676 Strap - Jumper (50 Hz Motor Unit) .....	3