



# CATALOG OF REPLACEMENT PARTS

## FT-600 & FT-700 SERIES DISHWASHERS

### 96" DISCHARGE (Unloading) UNIT (INCLUDES MOTOR PARTS)

R. to L.	L. to R.	
ML-19234	ML-18543	FT-600 W/O Dryer
ML-39144	ML-39142	FT-600 W/Dryer
ML-19414	ML-19415	FT-700 W/O Dryer
ML-39145	ML-39143	FT-700 W/Dryer

## INDEX

Page	Description
3	Conveyor Drive Motor Unit
4	Conveyor Motor Parts
5	Conveyor Drive Unit
7	Speed Reducer
9	Conveyor Safety Unit
11	Conveyor Brake
13	Tracks and Dish Guides
15	Dish Platform and Extension Panels (W/O Blower Dryer)
17	Dish Platform and Extension Panels (W/Blower Dryer)
19	Panels (R. to L.)
21	Panels (L. to R.)
23	Final Rinse Supply Piping
25	Miscellaneous
26	Curtain and Baffles (W/O Blower Dryer)
27	Vent Hood Unit (W/O Blower Dryer)
29	Blower Baffles and Vent
31	Dryer Control Box and Conduit (R. to L.)
33	Dryer Control Box and Conduit (L. to R.)
35	Control Panel (Blower Dryer)
37	Steam Heater (Blower Dryer)
39	Electric Heater (Blower Dryer)
41	Blower
43	Blower Motor Parts
45	Panels (Steam Dryer)
47	Panels (Electric Dryer)
48	Dryer Door

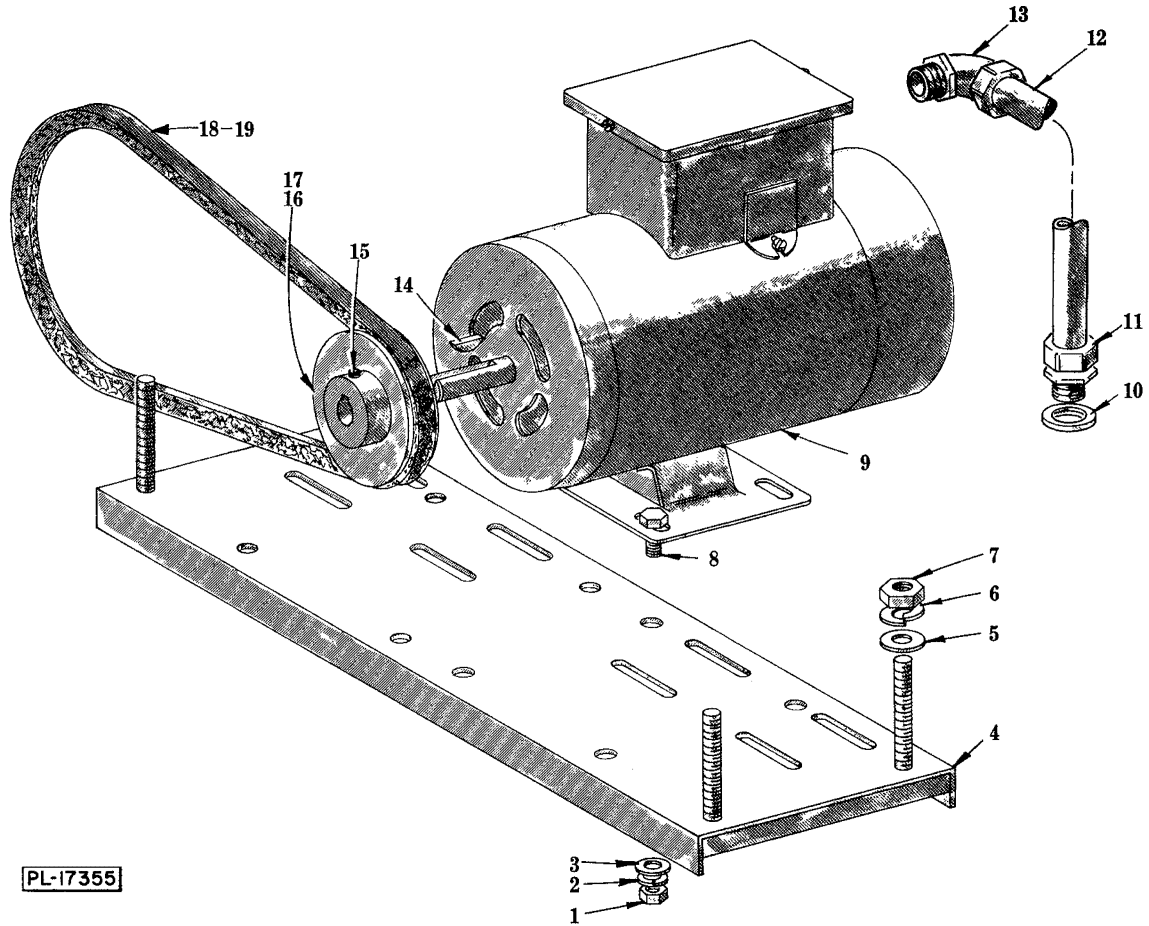

CONVEYOR DRIVE MOTOR UNIT

ILLUS. PL-17355	PART NO.	NAME OF PART	AMT.
	1	NS-13-11 Full Nut - 5/16"-18 Hex Fin	4
	2	WL-3-43 Lock Washer - 5/16" Light	4
	3	WS-5-1 Washer	4
	4	D-287186 Motor & Speed Reducer Base Assy	1
	5	WS-8-4 Washer	8
	6	WL-4-12 Lock Washer - 1/2" Light	4
	7	NS-13-30 Full Nut - 1/2"-13 Hex Fin	8
	8	SC-36-26 Cap Screw - 5/16"-18 x 7/8" Hex Hd	4
	9	ML-31341 Motor (Give Elec. Spec.)	1
	10	FE-8-11 3/4" Gasket Assy	1
	11	FE-8-23 Connector - Straight "Sealtite" (3/4" Male Thd. x 3/4" Flex. Cnd.)	1
	12	P-77657-4 Conduit - 3/4" x 14" (Waterproof)	1
	13	FE-8-25 Connector - 90° "Sealtite" (3/4" Male Thd. x 3/4" Flex. Cnd.)	1
	14	KW-3-10 Key - #606 Woodruff	1
	15	SC-75-15 Set Screw - 5/16"-18 x 3/8" Soc. Hdls., Cup Pt	1
	*16	C-115018-2 Sheave - Motor (2.6" Pitch Dia.) (Incls. item #15)	1
	**17	C-115018-4 Sheave - Motor (4" Pitch Dia.) (Incls. item #15)	1
	*18	BV-10-11 "V" Belt	1
	**19	BV-10-12 "V" Belt	1

\*FT-600.

\*\*FT-700.

96 DISCHARGE REPLACEMENT PARTS

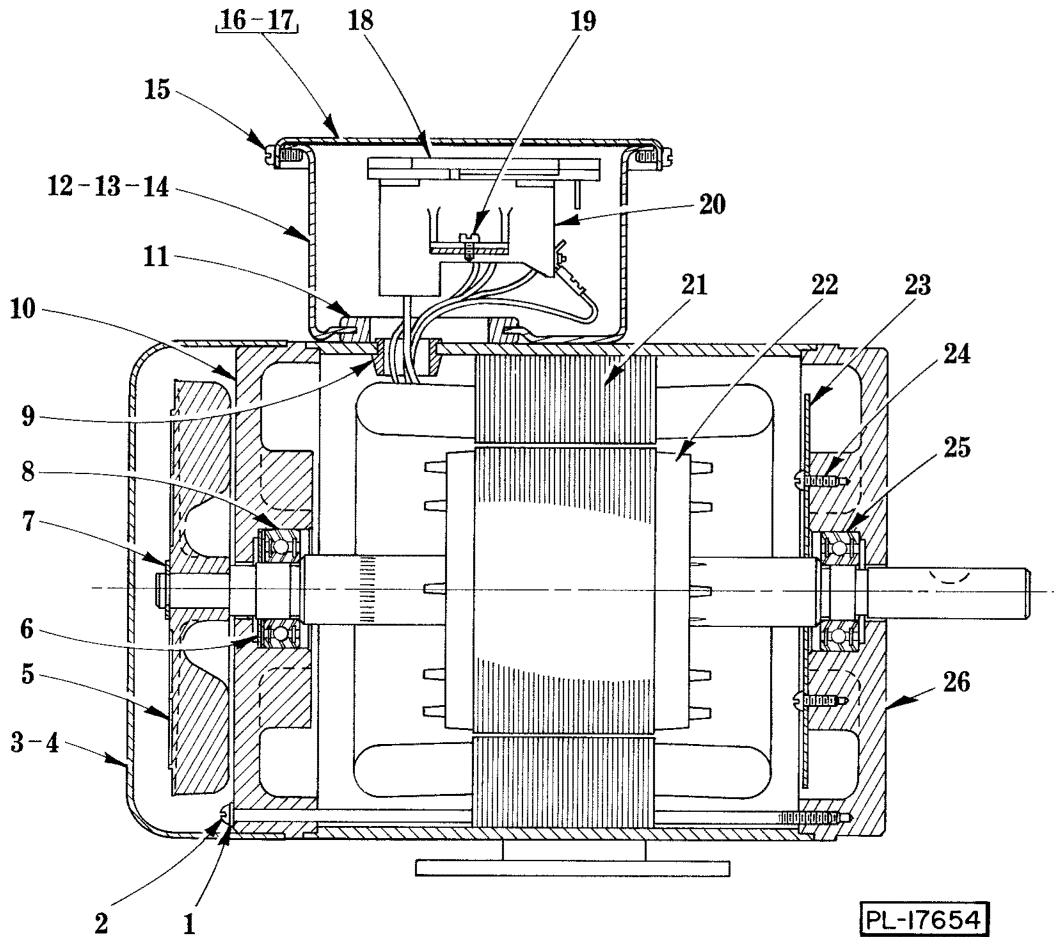

MOTOR UNIT

ILLUS. PL-17654	PART NO.	NAME OF PART	AMT.
1	WL-8-13	Lock Washer - #10 Int. Shakeproof . . . . .	4
2	SC-60-68	Mach. Screw - #10-24 x 7-1/2" Rd. Hd . . . . .	4
3	R-77067	Cover - Motor End . . . . .	1
4	SC-9-65	Mach. Screw - #8-32 x 1/4" Rd. Hd. (Not Shown) . . . . .	2
5	D-111493-1	Fan - Ventilating . . . . .	1
6	SL-2-4	Loading Spring - N.D. #S-17 . . . . .	1
7	RR-4-17	Retaining Ring . . . . .	1
8	BB-20-18	Ball Bearing - N.D. #77503 . . . . .	1
9	M-79118	Bushing - Snap (Field Ring) . . . . .	1
10	D-114379-2	Bracket - Bearing (Fan End) . . . . .	1
11	M-60395	Grommet . . . . .	1
12	D-113403	Box - Terminal . . . . .	1
13	SD-15-27	Self-Tapping Screw - #10-24 x 5/16" Pan Hd. "Taptite" (Not Shown) . . . . .	2
14	WL-7-12	Lock Washer - #10 Ext. Shakeproof (Not Shown) . . . . .	2
15	SD-12-45	Self-Tapping Screw - #8-32 x 5/16" Pan Hd., Type 23 . . . . .	2
16	C-113405	Cover - Terminal Box . . . . .	1
17	B-114811	Gasket - Terminal Box Cover . . . . .	1
18	C-113417	Connector Block Assy . . . . .	1
19	SD-12-45	Self-Tapping Screw - #8-32 x 5/16" Pan Hd., Type 23 . . . . .	2
20	C-113552	Terminal Block Base Assy . . . . .	1
21	D-65478-128-1	Stator Assy. (200-240 V./400-480 V.; 60 Hz.) . . . . .	1
22	C-15747-281	Rotor Assy . . . . .	1
23	P-81949	Baffle - Air . . . . .	1
24	SC-9-70	Mach. Screw - #6-32 x 1/4" Rd. Hd . . . . .	2
25	BB-20-18	Ball Bearing - N.D. #77503 . . . . .	1
26	D-114379-5	Bracket - Bearing (Pulley End) . . . . .	1

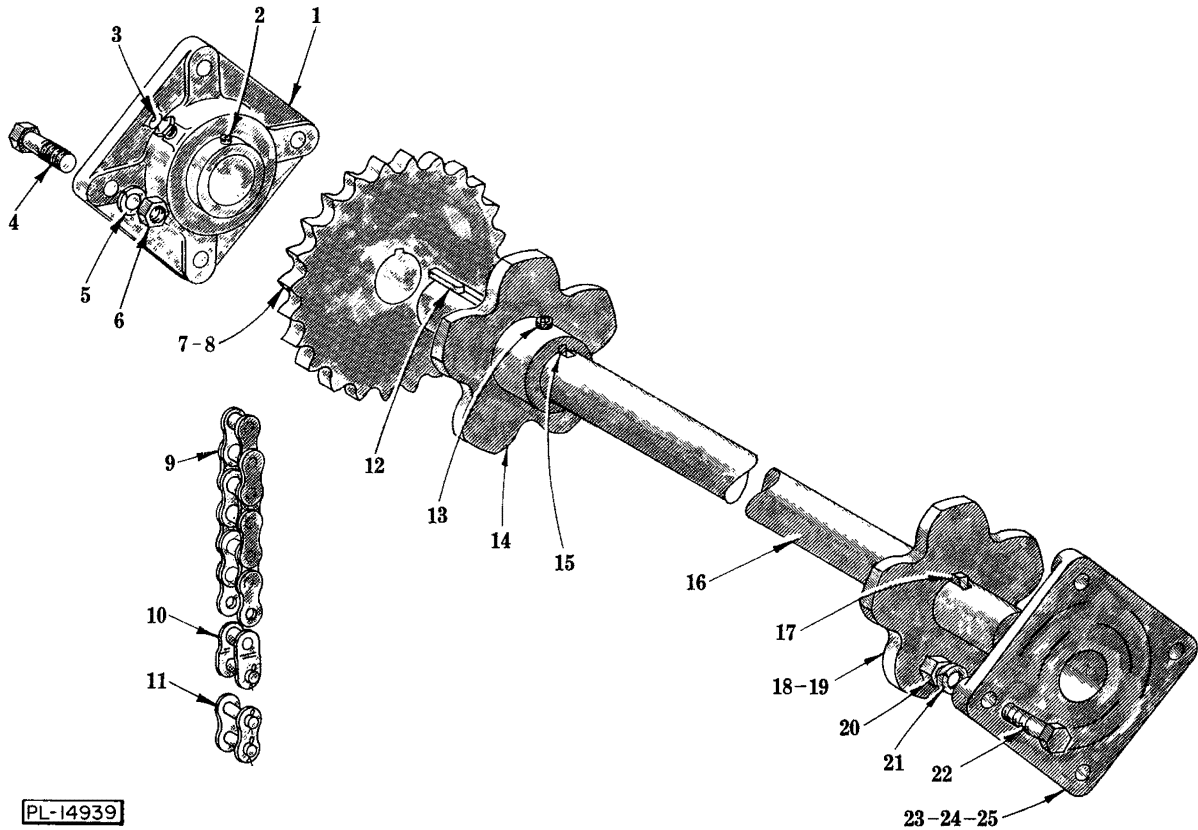

PL-14939

CONVEYOR DRIVE UNIT

ILLUS. PL-14939	PART NO.	NAME OF PART	AMT.
1	R-81656	Bearing - Flange (Incls. item #3)	1
2	SC-47-28	Set Screw - 1/4"-20 x 3/8" Soc. Hdls., Kn. Cup Pt	1
3	OG-3-1	Fitting - Hydraulic (1/8" Pipe Thd.)	1
4	SC-41-32	Cap Screw - 3/8"-16 x 1-1/2" Hex Hd	2
5	WL-6-27	Lock Washer - 3/8" Light	2
6	NS-15-13	Full Nut - 3/8"-16 Hex Fin	2
7	P-62771	Sprocket - Driven (24T) (Incls. item #8)	1
8	SC-48-22	Set Screw - 3/8"-16 x 3/4" Sq. Hd., Cup Pt	1
9	P-62804-5	Chain - Drive (42-3/4" Lg., 57 Pitches)	1
10	M-62805	Half Link - Drive Chain Connecting	AR
11	M-62803	Link - Drive Chain Connecting	AR
12	R-12430-148	Key	1
13	SC-47-41	Set Screw - 3/8"-16 x 3/8" Soc. Hdls., Cup Pt	1
14	R-82654-1	Conveyor Chain Sprocket Assy. (5T) (Incls. item #13)	1
15	R-12430-163	Key	1
16	B-156518	Shaft - Conveyor Drive	1
17	R-12430-163	Key	1
18	R-82654-1	Conveyor Chain Sprocket Assy. (5T) (Incls. item #19)	1
19	SC-47-41	Set Screw - 3/8"-16 x 3/8" Soc. Hdls., Cup Pt	1
20	NS-15-13	Full Nut - 3/8"-16 Hex Fin	2
21	WL-6-27	Lock Washer - 3/8" Light	2
22	SC-41-32	Cap Screw - 3/8"-16 x 1-1/2" Hex Hd	2
23	R-81656	Bearing - Flange (Incls. item #25)	1
24	SC-47-28	Set Screw - 1/4"-28 x 3/8" Soc. Hdls., Kn. Cup Pt	1
25	OG-3-1	Fitting - Hydraulic (1/8" Pipe Thd.)	1

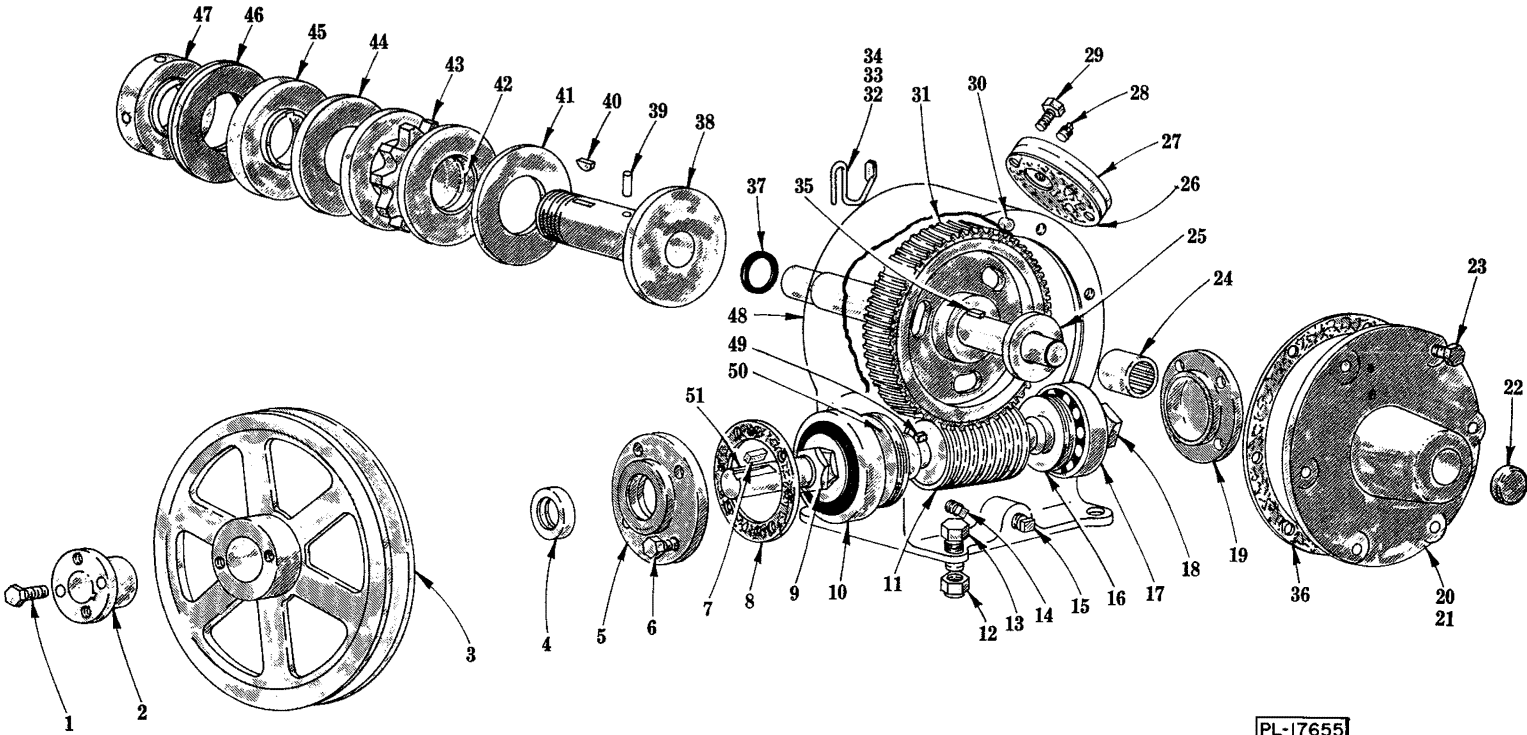

PL-17655

SPEED REDUCER

## SPEED REDUCER

ILLUS. PL-17655	PART NO.	NAME OF PART	AMT.
1	SC-36-13	Cap Screw - 1/4"-20 x 3/4" Hex Hd . . . . .	2
2	M-62205	Bushing - Conveyor Drive Sheave . . . . .	1
3	P-62202-11	Sheave (6.2" P.D.) . . . . .	1
4	B-121529	Seal - Oil . . . . .	1
5	P-77075	Seal Box & Oil Seal Assy. (Incls. item #4) . . . . .	1
6	SC-36-25	Cap Screw - 5/16"-18 x 3/4" Hex Hd . . . . .	8
7	R-12430-75	Key . . . . .	1
8	M-66540	Gasket . . . . .	2
9	M-66538-1	Lock Nut - Ball Bearing (L.H. Thd.) . . . . .	2
10	BB-7-46	Ball Bearing - N.D. #7506 . . . . .	1
11	C-66535-2	Worm (1T) (60 Hz.) . . . . .	1
12	NS-31-38	Stop Nut - 1/2"-13 "Elastic" . . . . .	4
13	SC-37-21	Cap Screw - 1/2"-13 x 1-1/2" Hex Hd . . . . .	4
14	FP-28-5	Plug - 1/4" Sq. Hd. Pipe . . . . .	2
19	FP-28-13	Plug - 1/2" Sq. Hd. Pipe . . . . .	2
16	M-13212-1	Grease Conveyor (R.H.) . . . . .	1
17	BB-7-47	Ball Bearing - N.D. #7606 . . . . .	1
18	M-66538-2	Lock Nut - Ball Bearing (R.H. Thd.) . . . . .	2
19	P-67029	Cover - Ball Bearing . . . . .	1
20	P-77154	Blind End Face Plate, Plug & Brg. Assy. (Incls. items #22 & 24) . . . . .	1
21	P-77153	Drive End Face Plate & Brg. Assy. (Incls. item #24) . . . . .	1
22	M-62081	Plug - Face Plate . . . . .	1
23	SC-36-25	Cap Screw - 5/16"-18 x 3/4" Hex Hd . . . . .	12
24	BN-2-7	Needle Bearing (Torrington B-1616) . . . . .	2
25	M-61724	Washer - Thrust . . . . .	2
26	P-66544	Gasket . . . . .	1
27	P-66543	Cover - Oil Hole . . . . .	1
28	M-4133-2	Plug - Ventilating . . . . .	1
29	SC-36-25	Cap Screw - 5/16"-18 x 3/4" Hex Hd . . . . .	2
30	D-11800-88	Dowel . . . . .	2
31	P-62088-2	Worm Wheel & Shaft Assy. (60 Hz.) (Incls. item #35) . . . . .	1
32	M-62082	Wiper - Oil . . . . .	2
33	SC-7-77	Mach. Screw - #10-24 x 1/2" Rd. Hd . . . . .	4
34	WL-7-12	Lock Washer - #10 Ext. Shakeproof . . . . .	4
35	R-12430-176	Key . . . . .	1
36	P-66539	Gasket . . . . .	2
37	D-67500-11	"O" Ring . . . . .	1
38	P-63137	Hub - Clutch . . . . .	1
39	D-11800-230	Dowel . . . . .	1
40	KW-3-1	Key - #304 Woodruff . . . . .	1
41	V-16006	Disc - Friction . . . . .	1
42	M-74456	Bushing - Slip Clutch . . . . .	1
43	P-74621	Sprocket & Hub Assy . . . . .	1
44	V-16006	Disc - Friction . . . . .	1
45	P-63139	Disc - Clutch . . . . .	1
46	P-63141	Spring - Belleville . . . . .	2
47	P-63140	Nut . . . . .	1
48	S-66576	Shell . . . . .	1
49	R-12430-78	Key . . . . .	1
50	M-13213-1	Grease Conveyor (L.H.) . . . . .	1
51	R-73405	Shaft - Worm . . . . .	1
	P-63143	Slip Clutch Assy. (Incls. items #38 & 40 thru 47) . . . . .	1
	S-73916-18	Speed Reducer Assy. (R. to L. Operation) (Incls. items #5, 6, 8, 9, 10, 11, 14 thru 37, 48, 49, 50 & 51) . . . . .	1
	S-73916-4	Speed Reducer Assy. (L. to R. Operation) (Incls. items #5, 6, 8, 9, 10, 11, 14 thru 37, 48, 49, 50 & 51) . . . . .	1

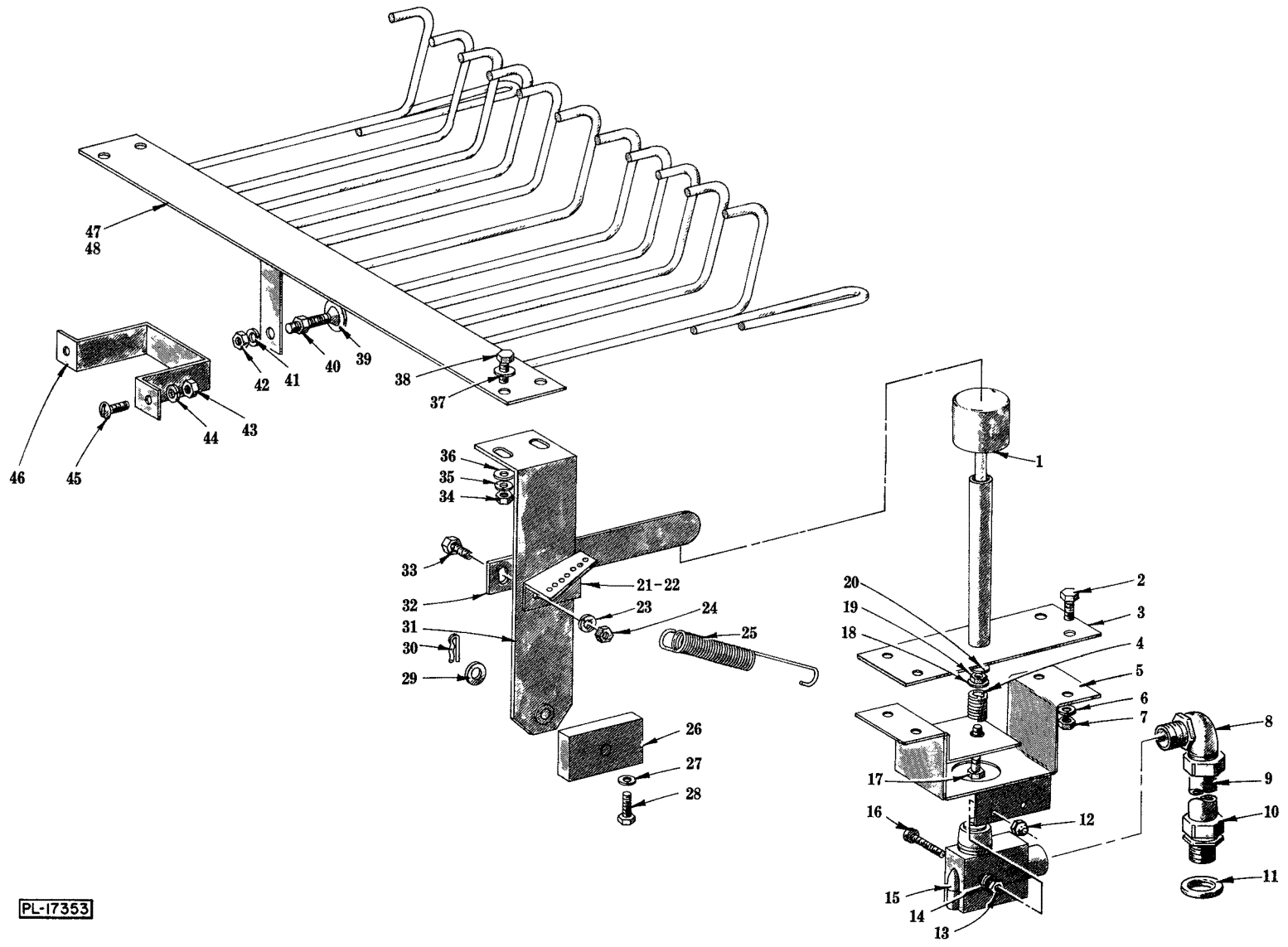

CONVEYOR SAFETY UNIT

PL-17353

## CONVEYOR SAFETY UNIT

ILLUS. PL-17353	PART NO.	NAME OF PART	AMT.
1	B-156684	Push Rod & Shield Assy . . . . .	1
2	SC-41-11	Cap Screw - 5/16"-18 x 3/4" Hex Hd . . . . .	4
3	P-67526-2	Plate & Guide Tube Assy . . . . .	1
4	M-67548	Spring - Interlock Switch . . . . .	1
5	R-87260	Interlock Switch Support Assy . . . . .	1
6	WL-6-22	Lock Washer - 5/16" Light . . . . .	4
7	NS-15-11	Full Nut - 5/16"-18 Hex Fin . . . . .	4
8	FE-6-37	Ell - 90° Short (1/2" Male Thd. x 1/2" Thinwall) . . . . .	1
9	P-67572-58	Conduit - 1/2" x 8-7/8" (Thinwall) . . . . .	1
10	FE-6-45	Connector - Straight (1/2" Male Thd. x 1/2" Thinwall) . . . . .	1
11	FE-8-10	1/2" Gasket Assy . . . . .	1
12	NS-31-50	Stop Nut - #6-32 "Elastic" . . . . .	2
13	NS-10-6	Mach. Nut - #6-32 Hex . . . . .	2
14	WS-2-6	Washer . . . . .	4
15	M-85617	Switch - Interlock (Incls. items #13, 14 & 16) . . . . .	1
16	SC-27-24	Mach. Screw - #6-32 x 1-1/2" Rd. Hd . . . . .	2
17	M-68205	Bolt - Special . . . . .	1
18	WS-17-6	Washer . . . . .	1
19	NS-18-1	Jam Nut - 1/4"-20 Hex Fin . . . . .	1
20	WS-17-6	Washer . . . . .	1
21	A-156622-1	Bracket - Spring Adjustment (Front, R. to L.; Rear, L. to R.) . . . . .	1
22	A-156622-2	Bracket - Spring Adjustment (Front, L. to R.; Rear, R. to L.) (Not Shown) . . . . .	1
23	WL-6-22	Lock Washer - 5/16" Light . . . . .	4
24	NS-15-11	Full Nut - 5/16"-18 Hex Fin . . . . .	4
25	P-62528	Spring - Conveyor Trip . . . . .	2
26	A-156678	Pivot Block Assy . . . . .	2
27	WL-6-22	Lock Washer - 5/16" Light . . . . .	4
28	SC-41-11	Cap Screw - 5/16"-18 x 3/4" Hex Hd . . . . .	4
29	WS-6-27	Washer . . . . .	2
30	M-66233	Retainer (Safety Stop Bracket Assy.) . . . . .	2
31	C-120250	Safety Stop Bracket Assy . . . . .	2
32	A-156681	Arm - Interlock Switch Actuating (Front) . . . . .	1
33	SC-41-11	Cap Screw - 5/16"-18 x 3/4" Hex Hd . . . . .	4
34	NS-15-11	Full Nut - 5/16"-18 Hex Fin . . . . .	4
35	WL-6-22	Lock Washer - 5/16" Light . . . . .	4
36	WS-17-8	Washer . . . . .	4
37	WS-17-8	Washer . . . . .	4
38	SC-41-11	Cap Screw - 5/16"-18 x 3/4" Hex Hd . . . . .	4
39	M-67508	Stop Plate & Screw Assy . . . . .	1
40	NS-15-11	Full Nut - 5/16"-18 Hex Fin . . . . .	1
41	WL-6-22	Lock Washer - 5/16" Light . . . . .	1
42	NS-15-11	Full Nut - 5/16"-18 Hex Fin . . . . .	1
43	NS-15-11	Full Nut - 5/16"-18 Hex Fin . . . . .	2
44	WL-6-22	Lock Washer - 5/16" Light . . . . .	2
45	SC-53-16	Mach. Screw - 5/16"-18 x 5/8" Truss Hd . . . . .	2
46	C-277865	Bracket - Stop (Safety Stop) . . . . .	1
47	D-156725	Conveyor Safety Stop Assy. (Type A Conveyor) (Incls. items #39 thru 42) . . . . .	1
48	D-156568	Conveyor Safety Stop Assy. (Type B Conveyor) (Incls. items #39 thru 42) (Not Shown) . . . . .	1

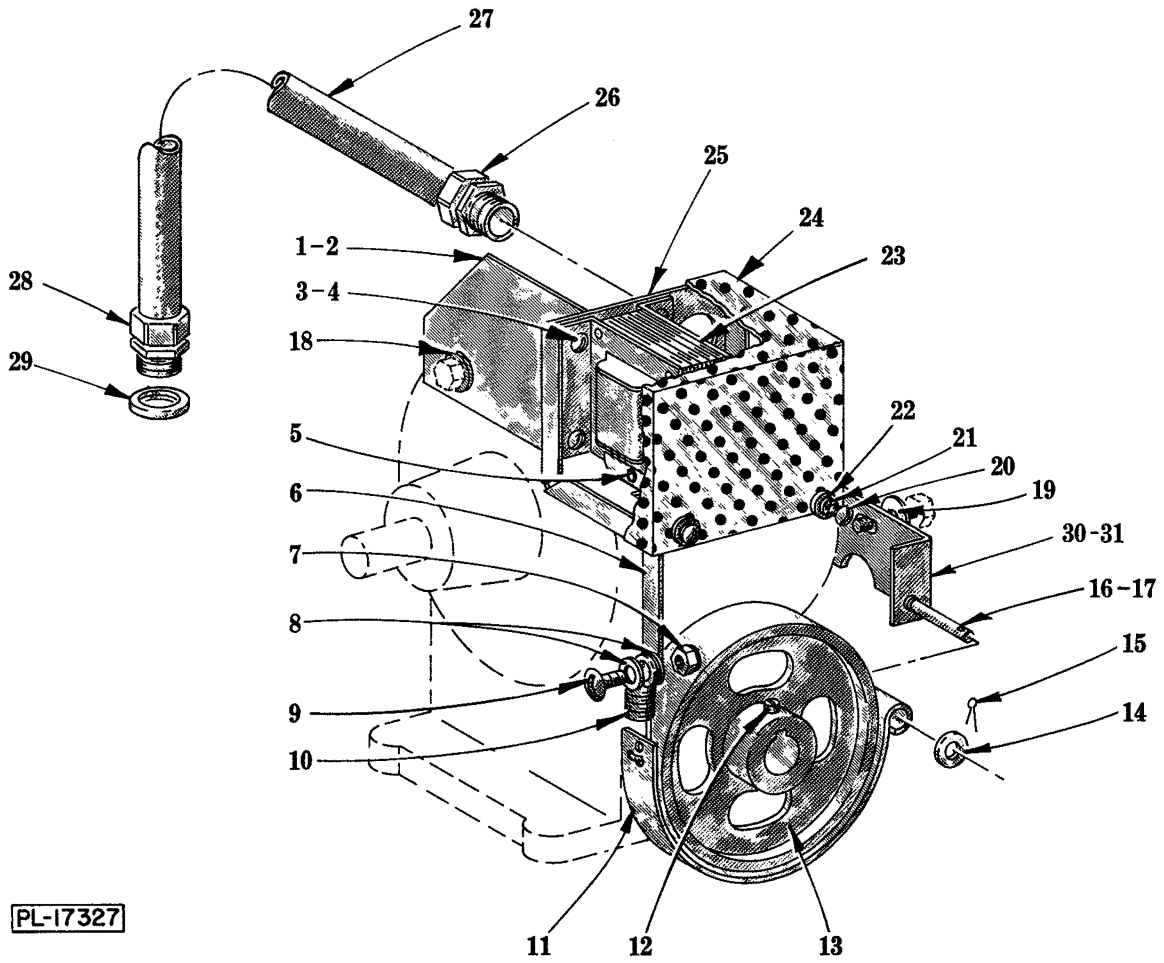

PL-17327

CONVEYOR BRAKE

## CONVEYOR BRAKE

ILLUS. PL-17327	PART NO.	NAME OF PART	AMT.
1	C-156716-1	Support - Brkt. (R. to L.) . . . . .	1
2	C-156716-2	Support - Brkt. (L. to R.) . . . . .	1
3	SC-21-39	Mach. Screw - 1/4"-20 x 5/8" Rd. Hd . . . . .	4
4	NS-31-19	Stop Nut - 1/4"-20 "Elastic" . . . . .	4
5	RP-2-30	Rollpin - .156" Dia. x 1-1/8" Lg . . . . .	1
6	A-156715	Bar - Tie . . . . .	1
7	NS-31-15	Stop Nut - #10-24 "Elastic" . . . . .	1
8	WS-3-5	Washer . . . . .	2
9	SC-21-24	Mach. Screw - #10-24 x 5/8" Rd. Hd . . . . .	1
10	M-24775	Spring - Motor Brake . . . . .	1
11	P-24776	Brake Band Assy . . . . .	1
12	SC-46-29	Set Screw - 1/4"-20 x 3/8" Hdls., Cup Pt . . . . .	1
13	R-73406	Drum - Brake . . . . .	1
14	WS-3-20	Washer . . . . .	1
15	PC-3-32	Cotter Pin - 3/32" x 1/2" . . . . .	1
16	M-24774	Stud - Brake Band . . . . .	1
17	NS-32-7	Stop Nut - 1/4"-20 "Flexloc" . . . . .	1
18	WS-4-25	Washer . . . . .	2
19	WS-4-25	Washer . . . . .	2
20	SC-21-7	Mach. Screw - #6-32 x 1/4" Rd. Hd . . . . .	6
21	WL-8-2	Lock Washer - #6 Int. Shakeproof . . . . .	6
22	WS-23-1	Washer . . . . .	6
23	P-77069-1	Solenoid - 115 V., 60 Hz . . . . .	1
24	R-83244	Shield - Solenoid Cover . . . . .	1
25	R-83243	Cover - Solenoid Support . . . . .	1
26	FE-7-1	Connector - Straight "Sealtite" (1/2" Male Thd. x 3/8" Flex. Cnd.) . . . . .	1
27	P-68190-10	Conduit - 3/8" x 29" (Waterproof) . . . . .	1
28	FE-7-1	Connector - Straight "Sealtite" (1/2" Male Thd. x 3/8" Flex. Cnd.) . . . . .	1
29	FE-8-10	1/2" Gasket Assy . . . . .	1
30	P-156164	Support - Brake Band Stud (R. to L.) . . . . .	1
31	P-73910	Support - Brake Band Stud (L. to R.) . . . . .	1

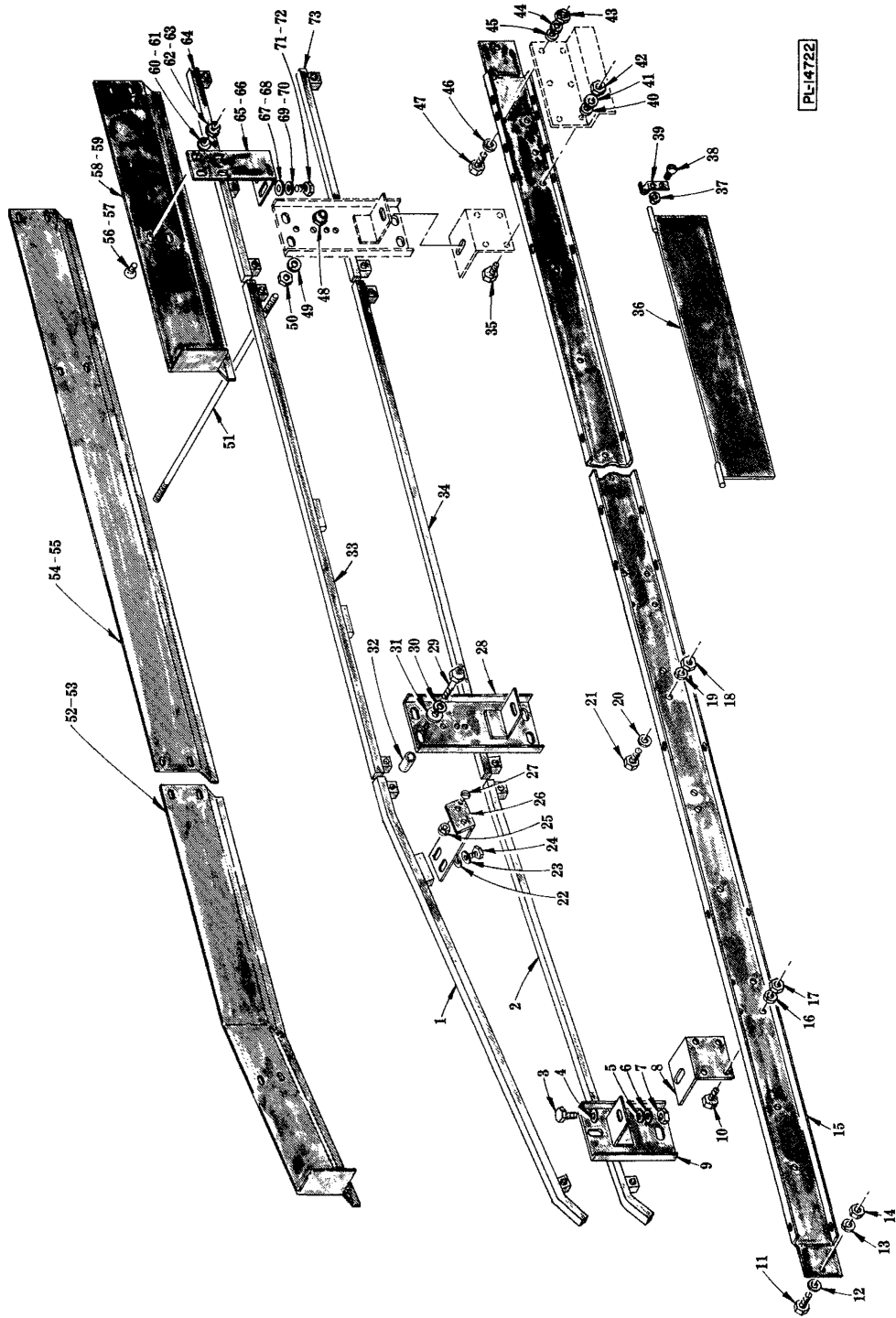

TRACKS AND DISH GUIDES

ILLUS. NO.	PART NO.	NAME OF PART	AMT.
1	D-118774-2	Upper Track Assy	2
2	D-118784-1	Lower Track Assy	2
3	SC-41-30	Cap Screw - 3/8"-16 x 1" Hex Hd	6
4	WS-6-44	Washer	6
5	WS-6-44	Washer	6

## TRACKS AND DISH GUIDES (Cont.)

ILLUS. PL-14722	PART NO.	NAME OF PART	AMT.
6	WL-6-27	Lock Washer - 3/8" Light	6
7	NS-15-13	Full Nut - 3/8"-16 Hex Fin	6
8	R-81010-1	Bracket - Track	6
9	D-120352-1	Track Support & Bracket Assy. (Short)	2
10	SC-41-12	Cap Screw - 5/16"-18 x 7/8" Hex Hd	22
11	SC-41-12	Cap Screw - 5/16"-18 x 7/8" Hex Hd	4
12	WS-17-8	Washer	4
13	WL-6-23	Lock Washer - 5/16" Medium	4
14	NS-15-11	Full Nut - 5/16"-18 Hex Fin	4
15	E-119519-2	Support - Tank	2
16	WL-6-23	Lock Washer - 5/16" Medium	22
17	NS-15-11	Full Nut - 5/16"-18 Hex Fin	22
18	NS-15-11	Full Nut - 5/16"-18 Hex Fin	14
19	WL-6-23	Lock Washer - 5/16" Medium	14
20	WS-17-8	Washer	14
21	SC-41-11	Cap Screw - 5/16"-18 x 3/4" Hex Hd	14
22	WS-17-8	Washer	4
23	WL-6-22	Lock Washer - 5/16" Light	4
24	SC-41-10	Cap Screw - 5/16"-18 x 5/8" Hex Hd	4
25	NS-31-15	Stop Nut - #10-24 "Elastic"	4
26	P-85753	Support - Extension Panel	2
27	SC-53-2	Mach. Screw - #10-24 x 1/2" Truss Hd	4
28	C-118793	Track Support & Bracket Assy	4
29	SC-41-60	Cap Screw - 1/2"-13 x 2" Hex Hd	24
30	WL-6-35	Lock Washer - 1/2" Light	24
31	WS-8-49	Washer	24
32	M-83204	Spacer - Track	24
33	D-118768-5	Upper Track Extension Assy	2
34	C-121017-4	Lower Track Extension Assy	2
35	SC-41-13	Cap Screw - 5/16"-18 x 1" Hex Hd	4
36	C-120784	Splash Shield & Pin Assy	1
37	NS-31-15	Stop Nut - #10-24 "Elastic"	4
38	SC-53-5	Mach. Screw - #10-24 x 3/8" Truss Hd	4
39	C-122065	Support - Splash Shield	2
40	WS-17-8	Washer	4
41	WL-6-23	Lock Washer - 5/16" Medium	4
42	NS-15-11	Full Nut - 5/16"-18 Hex Fin	4
43	NS-15-11	Full Nut - 5/16"-18 Hex Fin	2
44	WL-6-23	Lock Washer - 5/16" Medium	2
45	WS-17-8	Washer	2
46	WS-17-8	Washer	2
47	SC-41-11	Cap Screw - 5/16"-18 x 3/4" Hex Hd	2
48	NS-31-33	Stop Nut - 3/8"-16 "Elastic"	6
49	WL-6-27	Lock Washer - 3/8" Light	6
50	NS-15-13	Full Nut - 3/8"-16 Hex Fin	6
51	A-156661	Rod - Tie	3
**52	D-120286-1	Dish Guide (Front, R. to L.; Rear, L. to R.)	1
**53	D-120286-2	Dish Guide (Front, L. to R.; Rear, R. to L.) (Not Shown)	1
**54	D-119514-3	Dish Guide (Front, R. to L.; Rear, L. to R.)	1
**55	D-119514-4	Dish Guide (Front, L. to R.; Rear, R. to L.) (Not Shown)	1
*56	SC-53-2	Mach. Screw - #10-24 x 1/2" Truss Hd	8
**57	SC-53-2	Mach. Screw - #10-24 x 1/2" Truss Hd	20
*58	D-119510-1	Dish Guide (Front, R. to L.; Rear, L. to R.)	1
*59	D-119510-2	Dish Guide (Front, L. to R.; Rear, R. to L.) (Not Shown)	1
*60	WS-19-6	Washer	8
**61	WS-19-6	Washer	20
*62	NS-31-15	Stop Nut - #10-24 "Elastic"	8
**63	NS-31-15	Stop Nut - #10-24 "Elastic"	20
64	D-118768-3	Upper Track Extension Assy	2
*65	R-81059	Bracket - Dish Guide	2
**66	R-81059	Bracket - Dish Guide	6
*67	WS-17-8	Washer	4
**68	WS-17-8	Washer	12
*69	WL-6-22	Lock Washer - 5/16" Light	4
**70	WL-6-22	Lock Washer - 5/16" Light	12
*71	SC-41-10	Cap Screw - 5/16"-18 x 5/8" Hex Hd	4
**72	SC-41-10	Cap Screw - 5/16"-18 x 5/8" Hex Hd	12
73	C-121017-3	Lower Track Extension Assy	2

\*W/O Blower Dryer.

\*\*W/Blower Dryer.

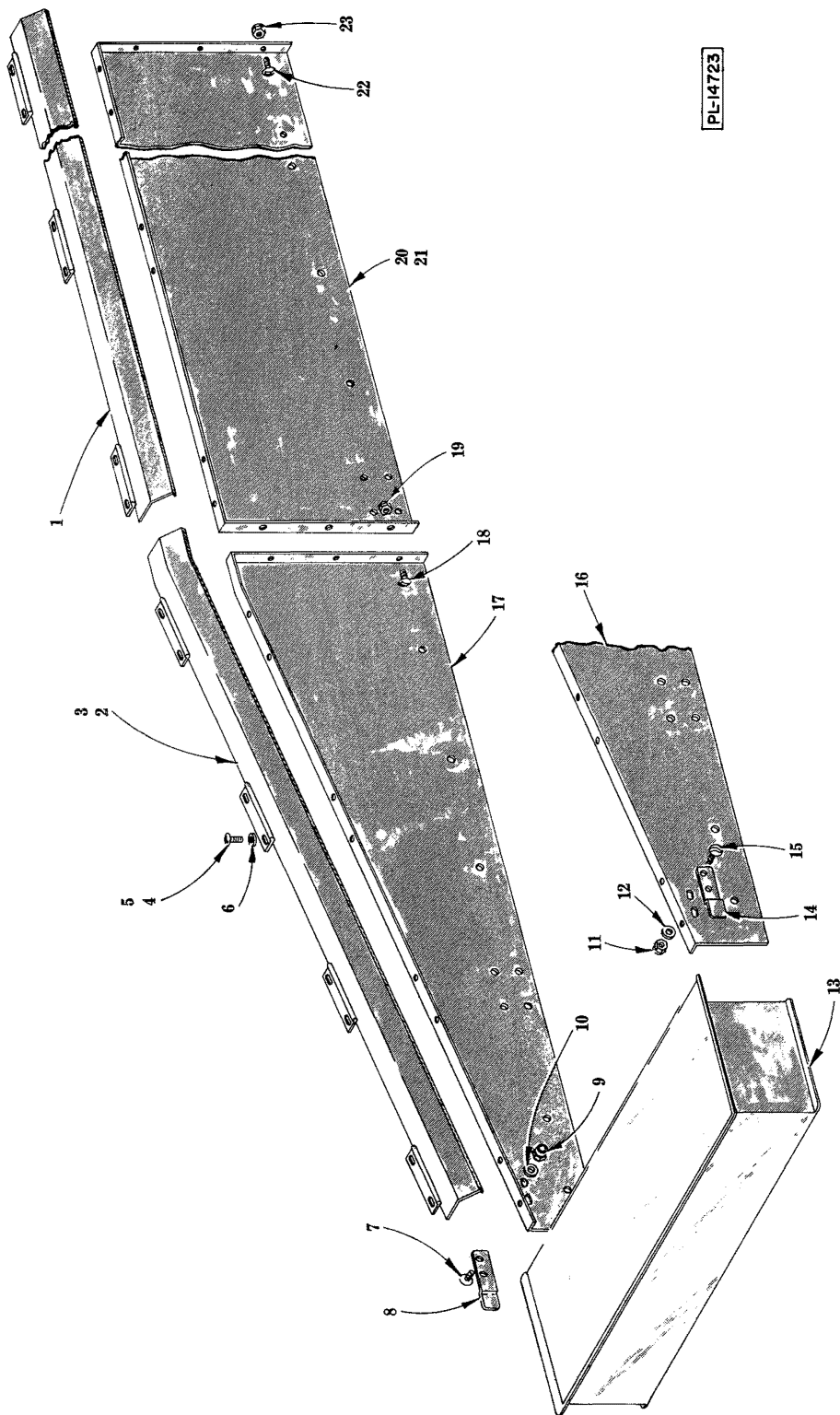

PL-14723

DISH PLATFORM AND EXTENSION PANELS  
(WITHOUT BLOWER DRYER)

**DISH PLATFORM AND EXTENSION PANELS  
(WITHOUT BLOWER DRYER)**

ILLUS. PL-14723	PART NO.	NAME OF PART	AMT.
1	D-118876-2	Conveyor Chain Cover Extension Assy . . . . .	2
2	D-118853-1	Conveyor Chain Cover Assy. (Rear, R. to L.; Front, L. to R.) . . . . .	1
3	D-118853-2	Conveyor Chain Cover Assy. (Front, R. to L.; Rear, L. to R.) (Not Shown) . . . . .	1
4	SC-53-2	Mach. Screw - #10-24 x 1/2" Truss Hd . . . . .	28
5	NS-31-15	Stop Nut - #10-24 "Elastic" . . . . .	28
6	WS-19-6	Washer . . . . .	28
7	SC-53-2	Mach. Screw - #10-24 x 1/2" Truss Hd . . . . .	2
8	C-119597	Latch - Dish Platform (Rear, R. to L.; Front, L. to R.) . . . . .	1
9	NS-31-15	Stop Nut - #10-24 "Elastic" . . . . .	2
10	WS-19-6	Washer . . . . .	2
11	NS-31-15	Stop Nut - #10-24 "Elastic" . . . . .	2
12	WS-19-6	Washer . . . . .	2
13	D-119654	Dish Platform Assy . . . . .	1
14	C-119596	Latch - Dish Platform (Front, R. to L.; Rear, L. to R.) . . . . .	1
15	SC-53-2	Mach. Screw - #10-24 x 1/2" Truss Hd . . . . .	2
16	E-118825-2	Panel - Extension (Front, R. to L.; Rear, L. to R.) . . . . .	1
17	E-118825-1	Panel - Extension (Rear, R. to L.; Front, L. to R.) . . . . .	1
18	SC-53-2	Mach. Screw - #10-24 x 1/2" Truss Hd . . . . .	6
19	NS-31-15	Stop Nut - #10-24 "Elastic" . . . . .	6
20	E-122604-1	Panel - Extension (Rear, R. to L.; Front, L. to R.) . . . . .	1
21	E-122604-2	Panel - Extension (Front, R. to L.; Rear, L. to R.) (Not Shown) . . . . .	1
22	SC-53-2	Mach. Screw - #10-24 x 1/2" Truss Hd . . . . .	6
23	NS-31-15	Stop Nut - #10-24 "Elastic" . . . . .	6

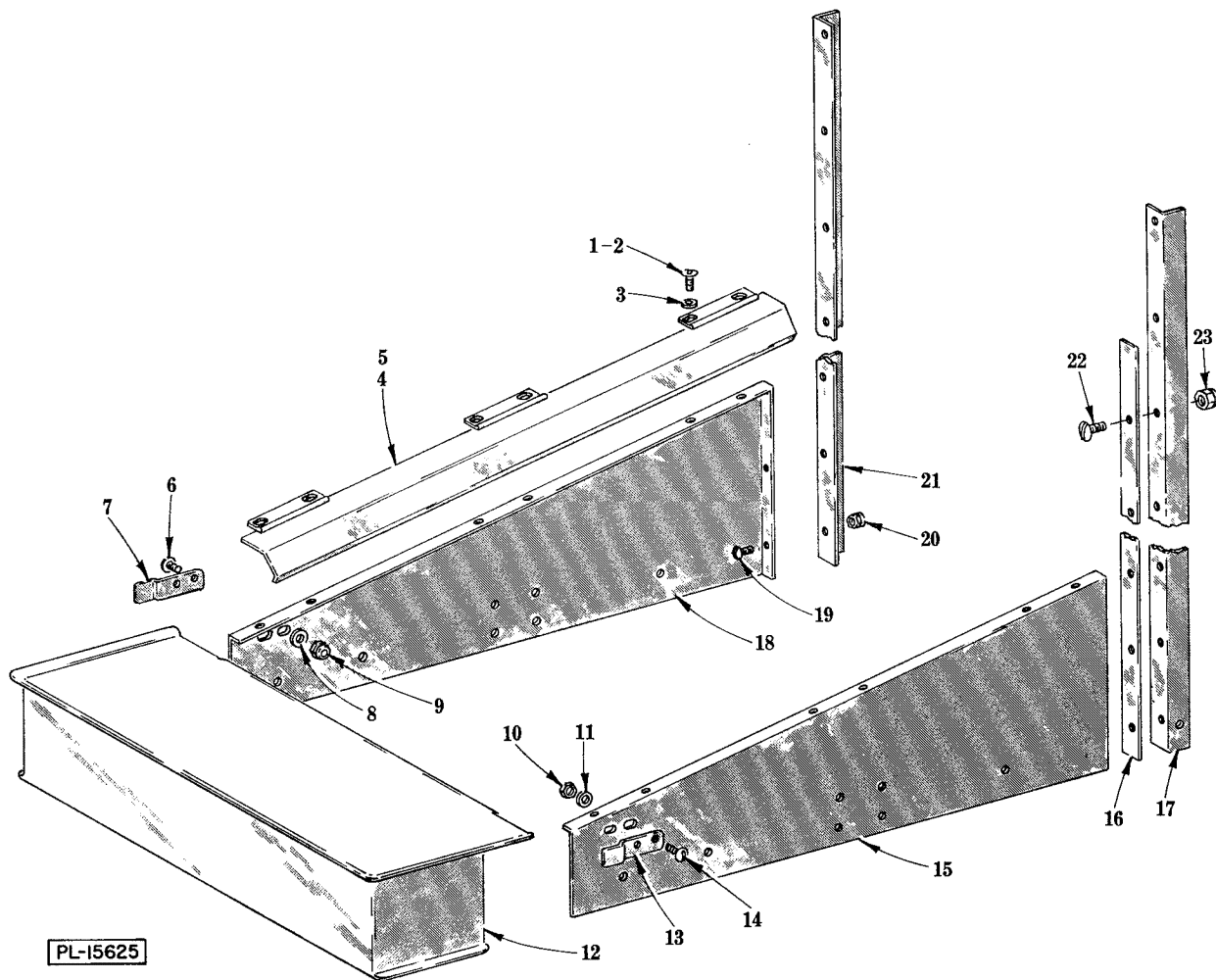

DISH PLATFORM AND EXTENSION PANELS  
(WITH BLOWER DRYER)

**DISH PLATFORM AND EXTENSION PANELS  
(WITH BLOWER DRYER)**

ILLUS. PL-15625	PART NO.	NAME OF PART	AMT.
1	SC-53-2	Mach. Screw - #10-24 x 1/2" Truss Hd . . . . .	12
2	NS-31-15	Stop Nut - #10-24 "Elastic" . . . . .	12
3	WS-19-6	Washer . . . . .	12
4	C-118934-1	Conveyor Chain Cover Assy. (Rear, R. to L.; Front, L. to R.) . . . . .	1
5	C-118934-2	Conveyor Chain Cover Assy. (Front, R. to L.; Rear, L. to R.) (Not Shown) . . . . .	1
6	SC-53-2	Mach. Screw - #10-24 x 1/2" Truss Hd . . . . .	2
7	C-119597	Latch - Dish Platform (Rear, R. to L.; Front, L. to R.) . . . . .	1
8	WS-19-6	Washer . . . . .	2
9	NS-31-15	Stop Nut - #10-24 "Elastic" . . . . .	2
10	NS-31-15	Stop Nut - #10-24 "Elastic" . . . . .	2
11	WS-19-6	Washer . . . . .	2
12	D-119654	Dish Platform Assy . . . . .	1
13	C-119596	Latch - Dish Platform (Front, R. to L.; Rear, L. to R.) . . . . .	1
14	SC-53-2	Mach. Screw - #10-24 x 1/2" Truss Hd . . . . .	2
15	E-118916-1	Panel - Extension (Front, R. to L.; Rear, L. to R.) . . . . .	1
16	C-119504	Spacer - Brace . . . . .	2
17	D-119501-1	Brace - Angle (Dryer) (Front, R. to L.; Rear, L. to R.) . . . . .	1
18	E-118916-2	Panel - Extension (Rear, R. to L.; Front, L. to R.) . . . . .	1
19	SC-53-2	Mach. Screw - #10-24 x 1/2" Truss Hd . . . . .	6
20	NS-31-15	Stop Nut - #10-24 "Elastic" . . . . .	6
21	D-119501-2	Brace - Angle (Dryer) (Rear, R. to L.; Front, L. to R.) . . . . .	1
22	SC-53-18	Mach. Screw - 5/16"-18 x 7/8" Truss Hd . . . . .	8
23	NS-32-35	Stop Nut - 5/16"-18 "Flexloc" . . . . .	8

PL-17577

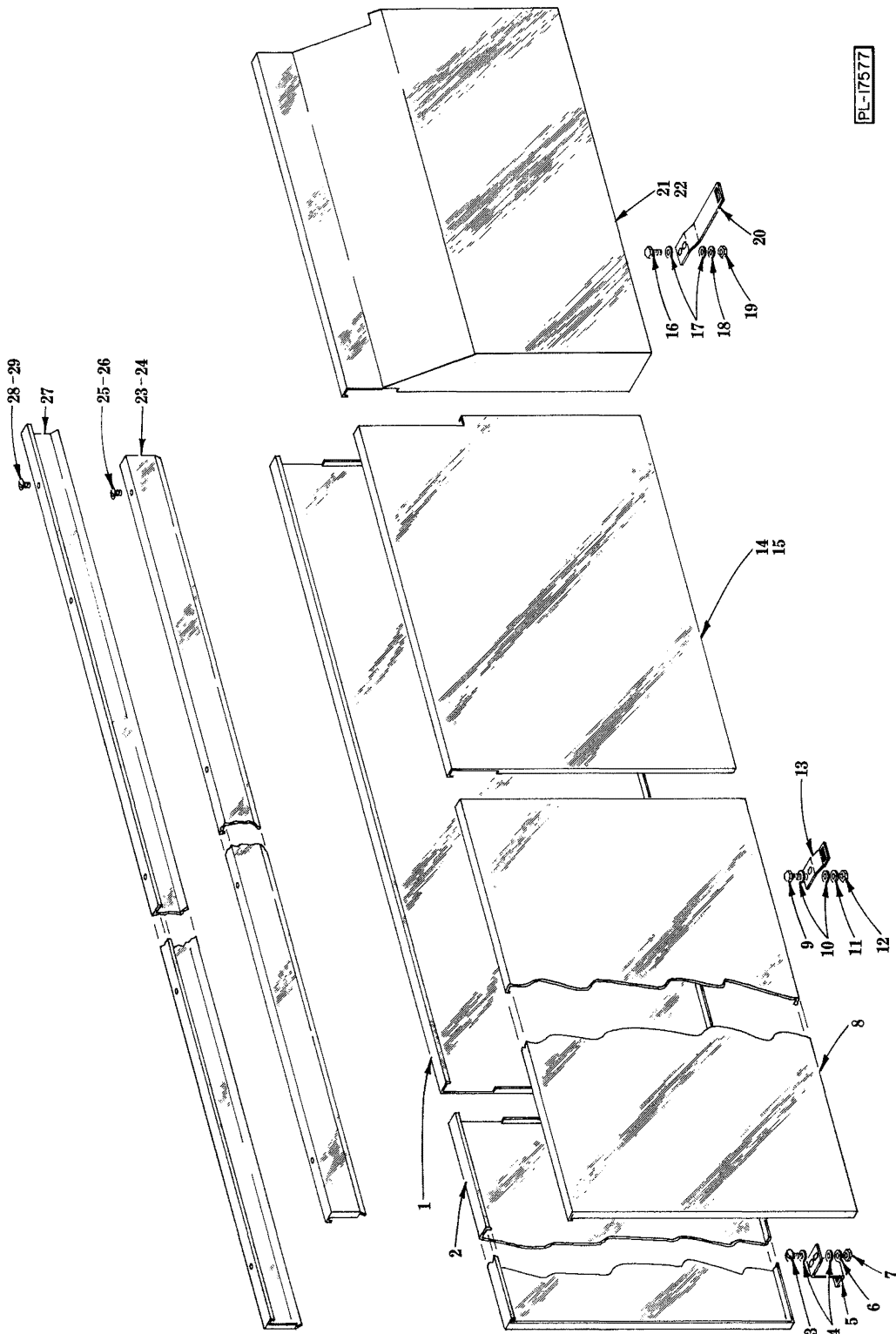

PANELS

**PANELS**  
(R. TO L. OPERATION)

ILLUS. PL-17577	PART NO.	NAME OF PART	AMT.
1	E-123159-11	Panel - Rear . . . . .	1
2	E-123159-5	Panel - Rear (End) . . . . .	1
3	SC-21-25	Mach. Screw - #10-24 x 3/4" Rd. Hd . . . . .	10
4	WS-19-6	Washer . . . . .	20
5	C-123100	Bracket - Panel Support (Rear) . . . . .	5
6	WL-6-16	Lock Washer - 1/4" Light . . . . .	10
7	NS-11-18	Mach. Nut - #10-24 Hex . . . . .	10
8	E-123160-6	Panel - Front (End) . . . . .	1
9	M-81921	Mach. Screw - #10-24 x 1/2" Trim, Hex Hd . . . . .	AR
10	WS-19-6	Washer . . . . .	AR
11	WL-6-16	Lock Washer - 1/4" Light . . . . .	AR
12	NS-11-18	Mach. Nut - #10-24 Hex . . . . .	AR
13	C-122835-1	Bracket - Panel Support (Front) . . . . .	AR
14	E-123160-18	Panel - Front (Use W/O Circuit Breakers) . . . . .	1
15	E-123160-14	Panel - Front (Use W/Circuit Breakers) . . . . .	1
16	M-81921	Mach. Screw - #10-24 x 1/2" Trim, Hex Hd . . . . .	4
17	WS-19-6	Washer . . . . .	8
18	WL-6-16	Lock Washer - 1/4" Light . . . . .	4
19	NS-11-18	Mach. Nut - #10-24 Hex . . . . .	4
20	C-122835-2	Bracket - Panel Support (Use W/Electric Booster) . . . . .	2
21	E-123205-5	Panel - Front (Use W/Electric Booster & W/O Circuit Breakers) . . . . .	1
22	E-123205-6	Panel - Front (Use W/Electric Booster & Circuit Breakers) . . . . .	1
23	D-276003-11	Panel - Trim (Front) (Use W/O Circuit Breakers) . . . . .	1
24	D-276003-12	Panel - Trim (Front) (Use W/Circuit Breakers) . . . . .	1
25	SC-53-4	Mach. Screw - #10-24 x 5/16" Truss Hd . . . . .	4
26	M-75895	Speed Nut - #10-24 . . . . .	4
27	D-276002-10	Panel - Trim (Rear) . . . . .	1
28	SC-53-4	Mach. Screw - #10-24 x 5/16" Truss Hd . . . . .	5
29	M-75895	Speed Nut - #20-24 . . . . .	5

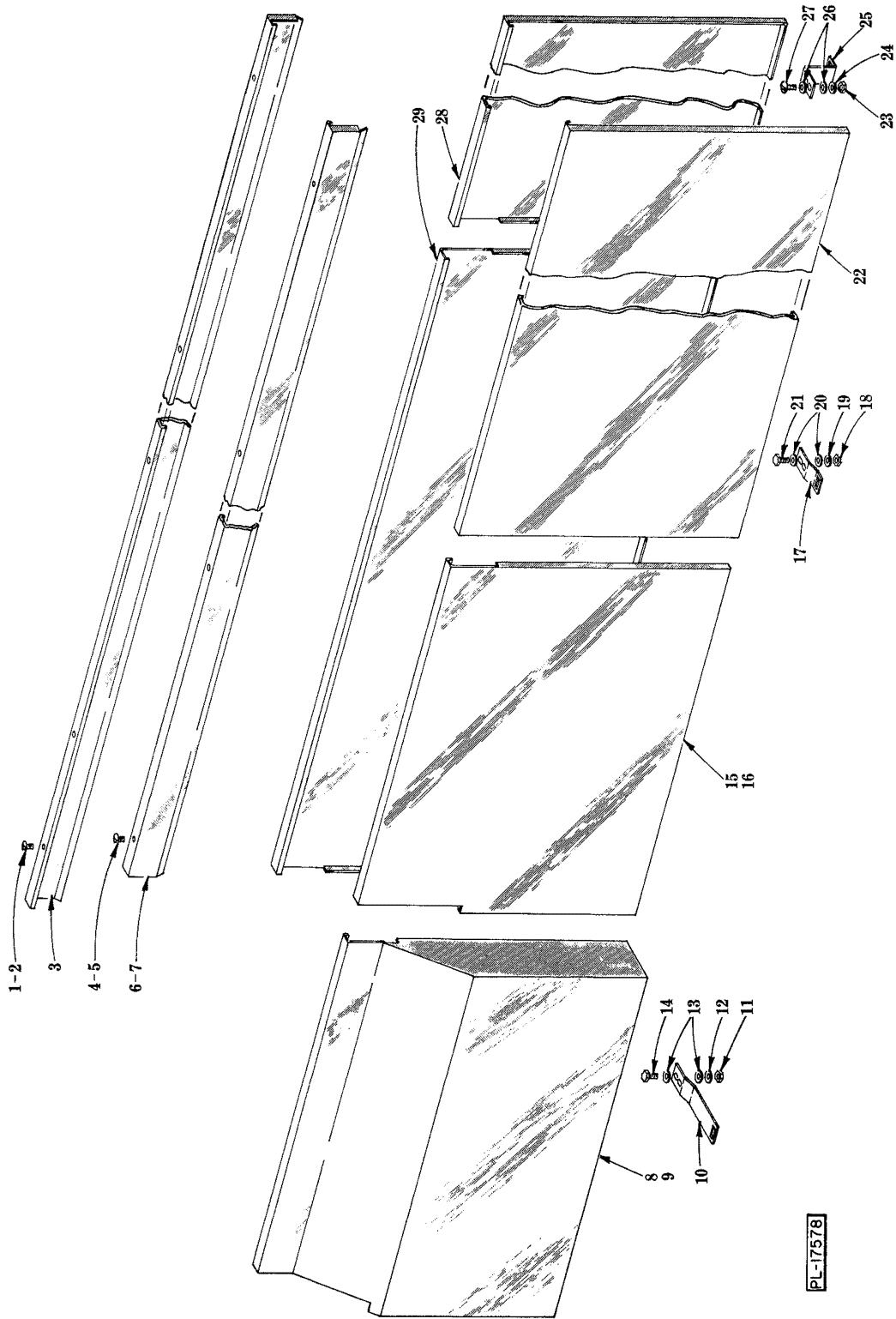

PANELS

**PANELS**  
(L. TO R. OPERATION)

ILLUS. PL-17578	PART NO.	NAME OF PART	AMT.
1	SC-53-4	Mach. Screw - #10-24 x 5/16" Truss Hd . . . . .	5
2	M-75895	Speed Nut - #10-24 . . . . .	5
3	D-276003-10	Panel - Trim (Rear) . . . . .	1
4	SC-53-4	Mach. Screw - #10-24 x 5/16" Truss Hd . . . . .	4
5	M-75895	Speed Nut - #10-24 . . . . .	4
6	D-276002-11	Panel - Trim (Front) (Use W/O Circuit Breakers) . . . . .	1
7	D-276002-12	Panel - Trim (Front) (Use W/Circuit Breakers) . . . . .	1
8	E-123205-7	Panel - Front (Use W/Elec. Booster & W/O Circuit Breakers) . . . . .	1
9	E-123205-8	Panel - Front (Use W/Elec. Booster & Circuit Breakers) . . . . .	1
10	C-122835-2	Bracket - Panel Support (Front) (Use W/Elec. Booster) . . . . .	2
11	NS-11-18	Mach. Nut - #10-24 Hex . . . . .	4
12	WL-6-16	Lock Washer - 1/4" Light . . . . .	4
13	WS-19-6	Washer . . . . .	8
14	M-81921	Mach. Screw - #10-24 x 1/2" Trim. Hex Hd . . . . .	4
15	E-123159-15	Panel - Front (Use W/O Circuit Breakers) . . . . .	1
16	E-123159-16	Panel - Front (Use W/Circuit Breakers) . . . . .	1
17	C-122835-1	Bracket - Panel Support (Front) . . . . .	AR
18	NS-11-18	Mach. Nut - #10-24 Hex . . . . .	AR
19	WL-6-16	Lock Washer - 1/4" Light . . . . .	AR
20	WS-19-6	Washer . . . . .	AR
21	M-81921	Mach. Screw - #10-24 x 1/2" Trim. Hex Hd . . . . .	AR
22	E-123159-6	Panel - Front (End) . . . . .	1
23	NS-11-18	Mach. Nut - #10-24 Hex . . . . .	10
24	WL-6-16	Lock Washer - 1/4" Light . . . . .	10
25	C-123100	Bracket - Panel Support (Rear) . . . . .	5
26	WS-19-6	Washer . . . . .	20
27	SC-21-25	Mach. Screw - #10-24 x 3/4" Rd. Hd . . . . .	10
28	E-123160-5	Panel - Rear (End) . . . . .	1
29	E-123159-11	Panel - Rear . . . . .	1

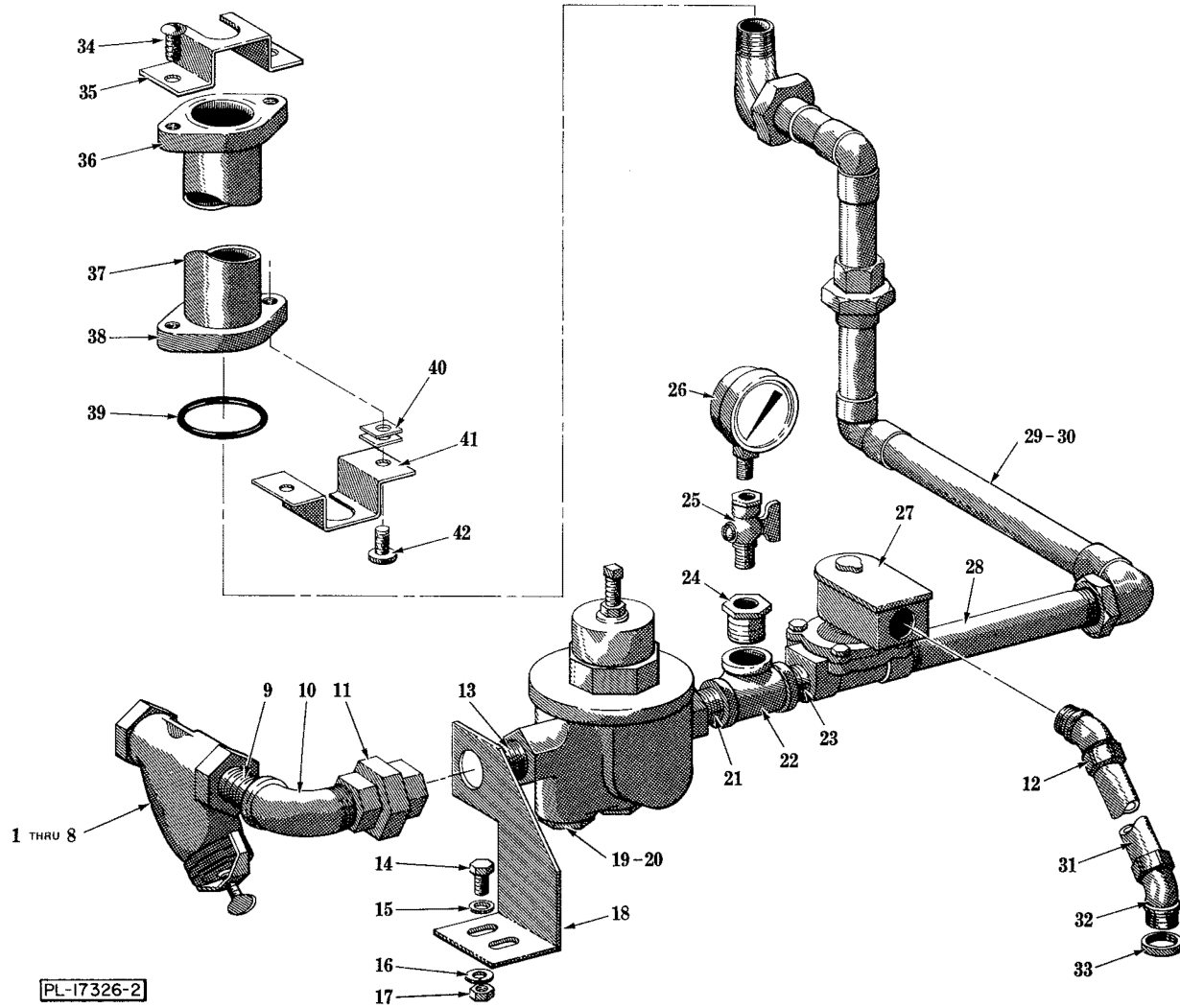

FINAL RINSE SUPPLY PIPING

## FINAL RINSE SUPPLY PIPING

ILLUS. PL-17326-2 NO.	PART	NAME OF PART	AMT.
1	M-82228	Line Strainer (3/4") (C.I.) (Incls. items #3, 4, 6, 7 & 8)	1
2	A-102516	Line Strainer (3/4") (Brass) (Incls. items #3, 5, 6, 7 & 8)	1
3	M-82231	Screen (3/4" Line Strainer)	1
4	M-82234	Plate - Seal (3/4" Line Strainer) (Use with item #1)	1
5	A-102517	Plate Seal (3/4" Line Strainer) (Use with item #2)	1
6	M-82236	Clamp (3/4" Line Strainer)	1
7	M-82238	Thumb Screw	1
8	D-67500-59	"O" Ring (3/4" Line Strainer)	1
9	FP-41-54	Nipple - 3/4" x 2" Lg. (T.B.E.)	1
10	FP-15-24	Elbow - 3/4" x 90° Street	1
11	FP-22-18	Union - 3/4"	1
12	FE-7-2	Connector - 45° "Sealtite" (1/2" Male Thd. x 3/8" Flex. Cnd.)	1
13	FP-41-50	Nipple - 3/4" x 1-3/8" Lg. (T.B.E.)	1
14	SC-41-11	Cap Screw - 5/16"-18 x 3/4" Hex Hd	2
15	WS-17-8	Washer	2
16	WL-6-22	Lock Washer - 5/16" Light	2
17	NS-15-11	Full Nut - 5/16"-18 Hex Fin	2
18	C-121965	Bracket - Hot Water Pipe	1
19	C-103534	Valve - Pressure Regulating (C.I.)	1
20	C-102513	Valve - Pressure Regulating (Brass)	1
21	FP-41-50	Nipple - 3/4" x 1-3/8" Lg. (T.B.E.)	1
22	FP-19-28	Tee - 3/4"	1
23	FP-41-50	Nipple - 3/4" x 1-3/8" Lg. (T.B.E.)	1
24	FP-27-15	Bushing - 3/4" to 1/4" Hex Reducing	1
25	P-86218	Pet Cock - 1/4"	1
26	C-277915	Gauge - Water Pressure	1
27	M-89445-5	Valve - 3/4" Solenoid (110-120 V.) (Incls. Coil)	1
28	FP-41-92	Nipple - 3/4" x 5-5/8" Lg. (T.B.E.)	1
29	D-276920-5	Hot Water Pipe Assy. (R-L)	1
30	D-276920-6	Hot Water Pipe Assy. (L-R)	1
31	P-68190-13	Conduit - 3/8" x 8" Waterproof	1
32	FE-7-2	Connector - 45° "Sealtite" (1/2" Male Thd. x 3/8" Flex. Cnd.)	1
33	FE-8-10	1/2" Gasket Assy	1
34	SC-53-17	Mach. Screw - 5/16"-18 x 3/4" Truss Hd	2
35	R-81713	Tube - Support	1
36	B-123363	Flange - Upper	1
37	C-123365-2	Tube - Protective	1
38	C-123364	Flange - Lower	1
39	D-67500-18	"O" Ring	1
40	A-121204	Shim	AR
41	R-81713	Tube - Support	1
42	SC-53-17	Mach. Screw - 5/16"-18 x 3/4" Truss Hd	2
	C-112062-1	Coil - 3/4" Solenoid Valve (Use with item #27)	1

96 DISCHARGE REPLACEMENT PARTS

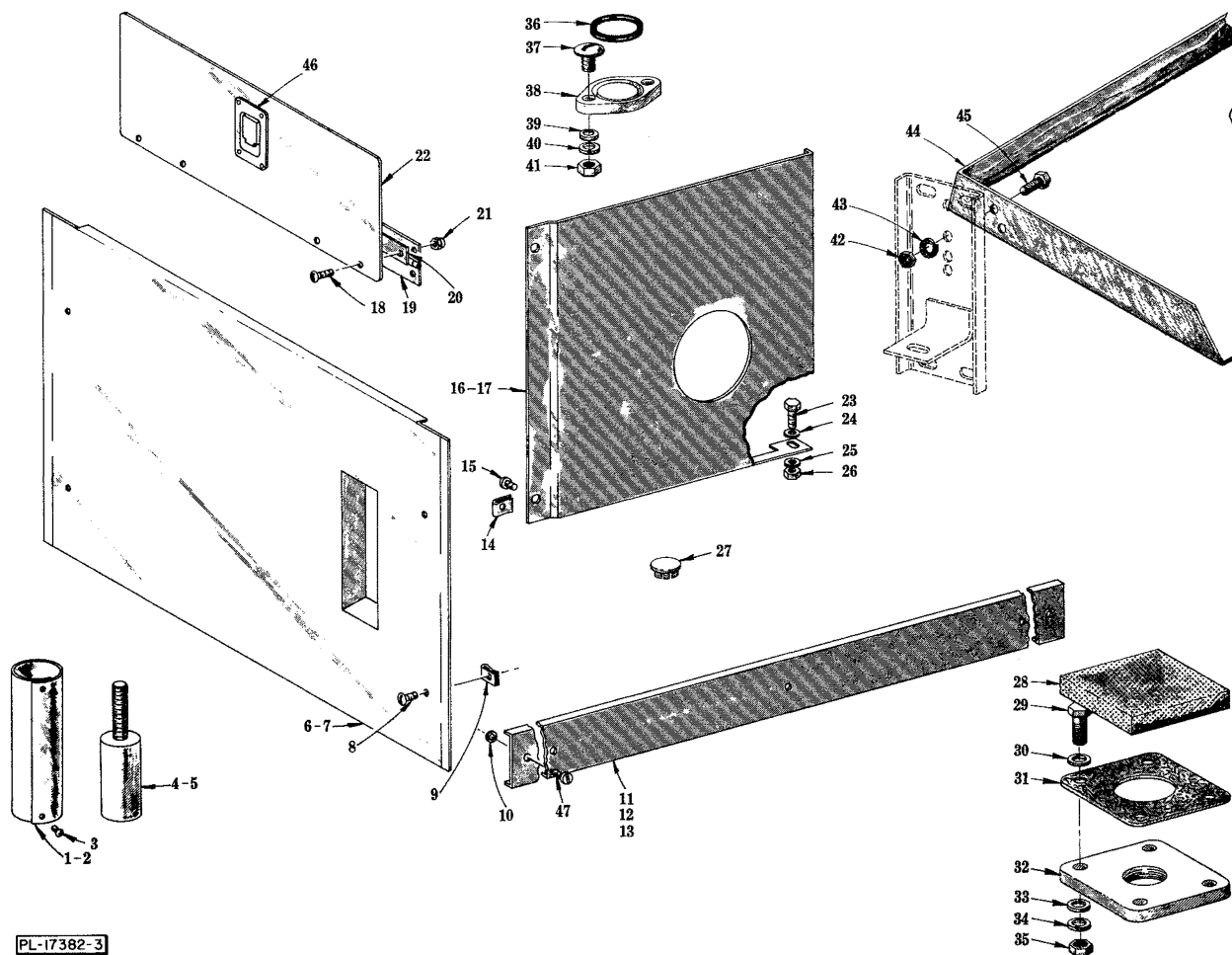

PL-17382-3

MISCELLANEOUS

MISCELLANEOUS

ILLUS. PL-17382-3	PART NO.	NAME OF PART	AMT.
1	C-120702	Trim - Short Leg (Front)	AR
2	R-81848	Trim - Leg (Rear)	AR
3	SD-7-15	Self-Tapping Screw - #6 x 3/16" Phil. Bind. Hd., Type B	AR
4	C-108821-1	Foot - Adjustable (STL)	4
5	C-108821-2	Foot - Adjustable (SST)	4
6	E-119747-8	End Panel Assy. (R. to L.)	1
7	E-121178-8	End Panel Assy. (L. to R.) (Not Shown)	1
8	SC-53-5	Mach. Screw - #10-24 x 3/8" Truss Hd	4
9	M-74348	Speed Nut - #10-24	4
10	B-112016	Retainer - Bolt	AR
11	D-118723-1	Cover - Channel (Use W/O Elec. Booster Circuit Breakers)	1
12	D-287316-4	Channel Cover Assy. (Use W/Elec. Booster Circuit Breakers, R. to L.)	1
13	D-287314-4	Channel Cover Assy. (Use W/Elec. Booster Circuit Breakers, L. to R.)	1
14	M-74398	Speed Nut - #10-24	2
15	SC-53-5	Mach. Screw - #10-24 x 3/8" Truss Hd	2
16	D-122058-1	Guard - Conveyor Sprocket (R. to L.)	1
17	D-122058-2	Guard - Conveyor Sprocket (L. to R.) (Not Shown)	1
18	SC-53-2	Mach. Screw - #10-24 x 1/2" Truss Hd	8
19	M-67177	Hinge	2
20	M-62788	Spacer - Hinge	2
21	NS-31-15	Stop Nut - #10-24 "Elastic"	8
22	C-102674	Door & Latch Assy. (Incls. item #46)	1
23	SC-41-12	Cap Screw - 5/16"-18 x 7/8" Hex Hd	1
24	WS-17-8	Washer	1
25	WL-6-22	Lock Washer - 5/16" Light	1
26	NS-15-11	Full Nut - 5/16"-18 Hex Fin	1
27	FE-21-12	Plug - Conduit 1/2"	AR
28	B-157957	Strainer Cover Assy	1
29	SC-41-31	Cap Screw - 3/8"-16 x 1-1/4" Hex Hd	4
30	WS-6-44	Washer	4
31	P-9934-1	Gasket	1
32	P-63240	Flange - Drain	1
33	WS-6-44	Washer	4
34	WL-6-27	Lock Washer - 3/8" Light	4
35	NS-15-13	Full Nut - 3/8"-16 Hex Fin	4
36	D-67500-20	"O" Ring	1
37	SC-53-20	Mach. Screw - 5/16"-18 x 1" Truss Hd	2
38	P-82429	Flange	1
39	WS-17-21	Washer	2
40	WL-6-22	Lock Washer - 5/16" Light	2
41	NS-15-11	Full Nut - 5/16"-18 Hex Fin	2
42	NS-15-11	Full Nut - 5/16"-18 Hex Fin	4
43	WL-6-22	Lock Washer - 5/16" Light	4
44	D-276928	Pan - Drain Back	1
45	SC-41-10	Cap Screw - 5/16"-18 x 5/8" Hex Hd	4
46	B-102672	Latch	1
47	B-112129	Screw - Captive	AR

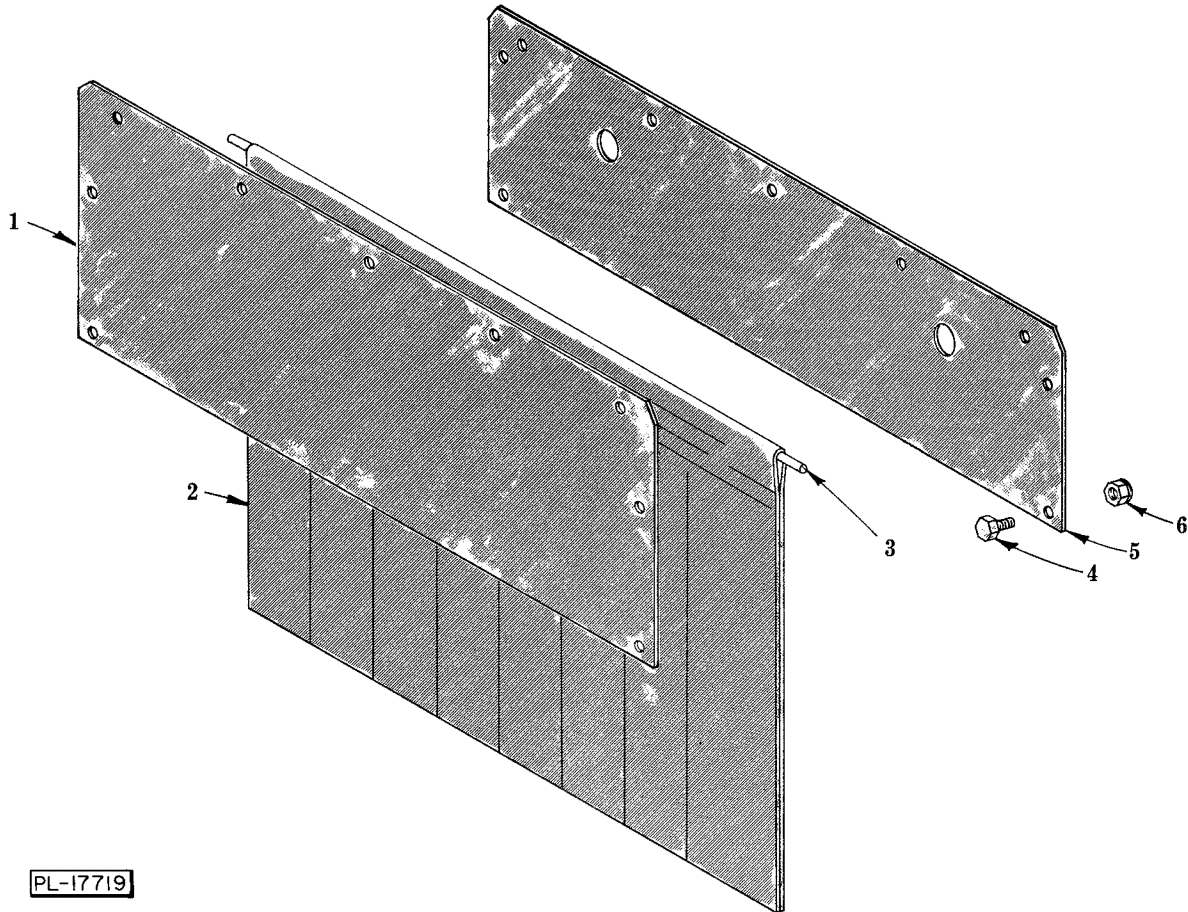

PL-17719

**CURTAIN AND BAFFLES  
(WITHOUT BLOWER DRYER)**

ILLUS. PL-17719	PART NO.	NAME OF PART	AMT.
1	D-276693-1	End Plate & Curtain Hook Assy . . . . .	1
2	E-120201-2	Curtain - Splash (15-E-3) . . . . .	1
3	B-120266-3	Rod - Splash Curtain . . . . .	1
4	SC-41-5	Cap Screw - 1/4"-20 x 5/8" Hex Hd . . . . .	9
5	D-118309	Baffle - End Plate (Inside) . . . . .	1
6	NS-31-19	Stop Nut - 1/4"-20 "Elastic" . . . . .	9
	D-120152-27	Curtain Assy. (15-E-3) (Incls. items #2 & 3) . . . . .	1

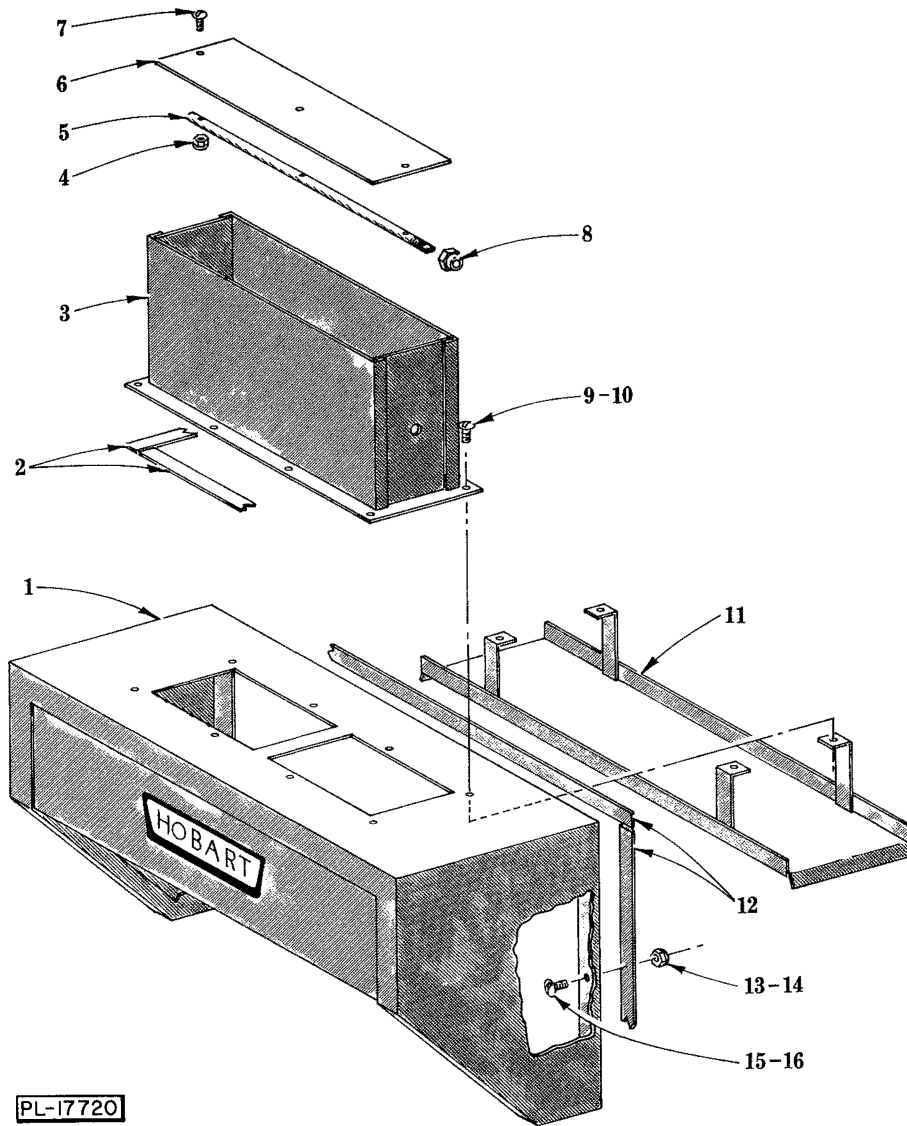

PL-17720

**VENT HOOD UNIT  
(WITHOUT BLOWER DRYER)**

ILLUS. PL-17720	PART NO.	NAME OF PART	AMT.
1	C-158694	Vent Hood Assy . . . . .	1
2	506150	Tape - Foam . . . . .	AR
3	R-75621	Vent Stack Assy . . . . .	1
4	NS-31-50	Stop Nut - #6-32 "Elastic" . . . . .	3
5	P-64919	Shaft - Damper . . . . .	1
6	P-75623	Damper - Vent Stack . . . . .	1
7	SC-21-11	Mach. Screw - #6-32 x 3/4" Rd. Hd . . . . .	3
8	NS-36-12	Stop Nut - 3/8"-24 "Elastic" . . . . .	1
9	SC-53-2	Mach. Screw - #10-24 x 1/2" Truss Hd . . . . .	8
10	NS-31-15	Stop Nut - #10-24 "Elastic" . . . . .	4
11	D-276702	Drip Shield Assy . . . . .	1
12	526408	Tape - Foam . . . . .	AR
13	NS-31-29	Stop Nut - 5/16"-18 "Elastic" . . . . .	4
14	NS-31-19	Stop Nut - 1/4"-20 "Elastic" . . . . .	7
15	SC-53-16	Mach. Screw - 5/16"-18 x 5/8" Truss Hd . . . . .	4
16	SC-41-5	Cap Screw - 1/4"-20 x 5/8" Hex Hd . . . . .	7

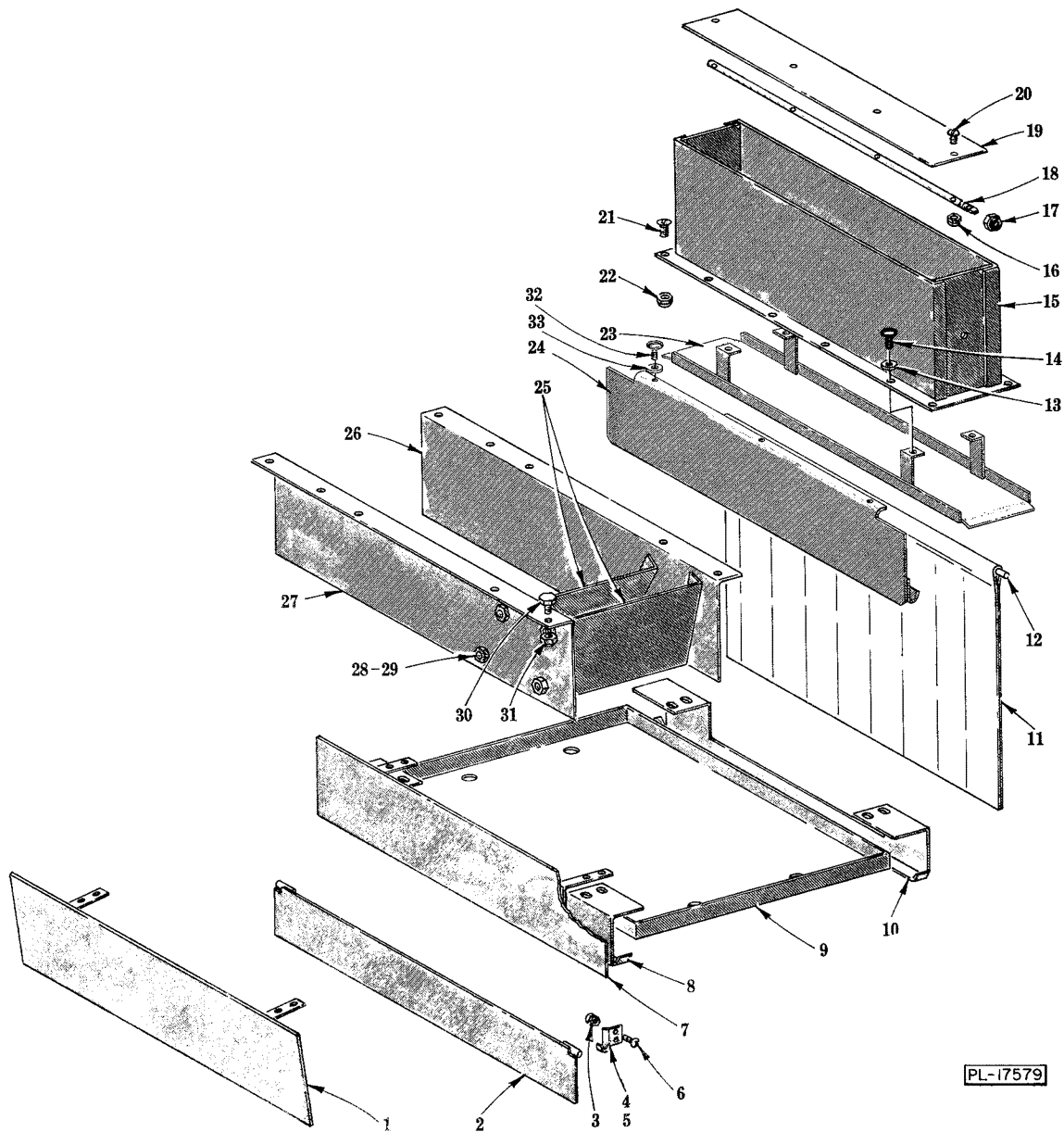

PL-17579

BLOWER BAFFLES AND VENT

## BLOWER BAFFLES AND VENT

ILLUS. PL-17579	PART NO.	NAME OF PART	AMT.
1	C-276039-1	Air Baffle Assy . . . . .	1
2	C-120922	Tank Air Baffle & Pin Assy . . . . .	1
3	NS-31-15	Stop Nut - #10-24 "Elastic" . . . . .	4
4	P-84922-2	Hook - Baffle (Front, R. to L.; Rear, L. to R.) . . . . .	1
5	P-84922-1	Hook - Baffle (Rear, R. to L.; Front, L. to R.) (Not Shown) . . . . .	1
6	SC-53-2	Mach. Screw - #10-24 x 1/2" Truss Hd . . . . .	4
7	C-276039-2	Air Baffle Assy . . . . .	1
8	D-118672	Support - Deflector Pan (Discharge End) . . . . .	1
9	D-123047	Pan - Deflector . . . . .	1
10	D-123048	Support - Deflector Pan (Entrance End) . . . . .	1
11	E-120201-2	Curtain - Splash (15-E-3) . . . . .	1
12	B-120266-3	Rod - Splash Curtain . . . . .	1
13	WL-6-6	Lock Washer - #10 Light . . . . .	4
14	SC-53-2	Mach. Screw - #10-24 x 1/2" Truss Hd . . . . .	4
15	C-157371	Vent Stack Assy . . . . .	1
16	NS-31-50	Stop Nut - #6-32 "Elastic" . . . . .	4
17	NS-36-12	Stop Nut - 3/8"-24 "Elastic" . . . . .	1
18	B-157374	Shaft - Damper . . . . .	1
19	B-157373	Damper - Vent Stack . . . . .	1
20	SC-21-11	Mach. Screw - #6-32 x 3/4" Rd. Hd . . . . .	4
21	SC-53-2	Mach. Screw - #10-24 x 1/2" Truss Hd . . . . .	8
22	NS-31-15	Stop Nut - #10-24 "Elastic" . . . . .	8
23	D-276702	Drip Shield Assy . . . . .	1
24	E-286834-1	Baffle Assy . . . . .	1
25	C-119499	Baffle - Air . . . . .	2
26	D-119980-2	Support - Deflector . . . . .	1
27	D-119980-1	Support - Deflector . . . . .	1
28	SC-53-5	Mach. Screw - #10-24 x 3/8" Truss Hd . . . . .	8
29	NS-31-15	Stop Nut - #10-24 "Elastic" . . . . .	8
30	SC-41-11	Cap Screw - 5/16"-18 x 3/4" Hex Hd . . . . .	3
31	NS-31-29	Stop Nut - 5/16"-18 "Elastic" . . . . .	3
32	SC-53-2	Mach. Screw - #10-24 x 1/2" Truss Hd . . . . .	3
33	WL-6-6	Lock Washer - #10 Light . . . . .	3
	D-120152-27	Curtain Assy. (15-E-3) (Incls. items #11 & 12) . . . . .	1

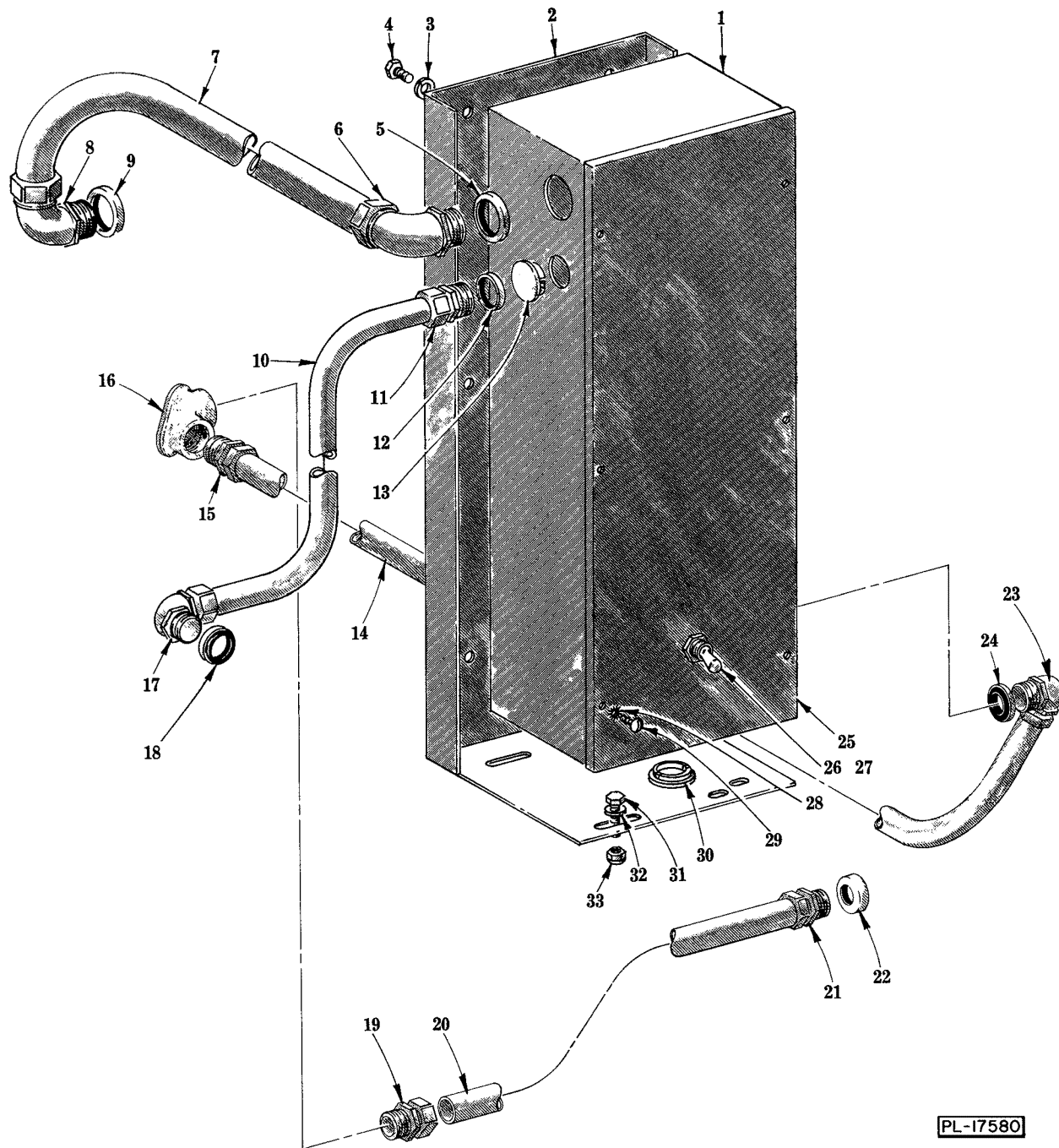

DRYER CONTROL BOX AND CONDUIT

**DRYER CONTROL BOX AND CONDUIT  
(R. TO L. OPERATION)**

ILLUS. PL-17580	PART NO.	NAME OF PART	AMT.
1	C-123073	Dryer Control Box Assy . . . . .	1
2	D-121205	Bracket - Dryer Control Box . . . . .	1
3	WL-6-16	Lock Washer - 1/4" Light . . . . .	6
4	SC-41-50	Cap Screw - 1/4"-20 x 1/2" Hex Hd . . . . .	6
5	FE-8-11	3/4" Gasket Assy . . . . .	1
6	FE-8-25	Connector - 90° "Sealtite" (3/4" Male Thd. x 3/4" Flex. Cnd.) . . . . .	1
7	P-77657-26	Conduit - 3/4" x 27" (Waterproof) . . . . .	1
8	FE-8-25	Connector - 90° "Sealtite" (3/4" Male Thd. x 3/4" Flex. Cnd.) . . . . .	1
9	FE-8-11	3/4" Gasket Assy . . . . .	1
*10	C-123153	Conduit - 1/2" Thinwall . . . . .	1
*11	FE-6-45	Connector - Straight (1/2" Male Thd. x 1/2" Thinwall) . . . . .	1
*12	FE-8-10	1/2" Gasket Assy . . . . .	1
13	FE-21-12	Plug - 1/2" (7/8" Dia. Hole) (Steam Dryer ONLY) . . . . .	1
14	C-276839	Conduit - Blower/Dryer . . . . .	1
15	FE-6-45	Connector - Straight (1/2" Male Thd. x 1/2" Thinwall) . . . . .	1
16	FE-7-31	Ell - 90° x 1/2" Pulling . . . . .	1
*17	FE-6-37	Ell - 90° Short (1/2" Male Thd. x 1/2" Thinwall) . . . . .	1
*18	FE-8-10	1/2" Gasket Assy . . . . .	1
19	FE-6-45	Connector - Straight (1/2" Male Thd. x 1/2" Thinwall) . . . . .	1
20	C-276838	Conduit - 1/2" Thinwall (Pulling Ell to Wiring Channel) . . . . .	1
21	M-83294	Connector - Straight (1/2" Male Thd. x 1/2" Thinwall) . . . . .	1
22	FE-8-10	1/2" Gasket Assy . . . . .	1
23	FE-6-37	Connector - 90° (1/2" Male Thd. x 1/2" Thinwall) . . . . .	1
24	FE-8-10	1/2" Gasket Assy . . . . .	1
25	D-123072	Cover - Control Box . . . . .	1
26	WL-8-32	Lock Washer - 1/2" Int. Shakeproof . . . . .	1
27	B-87711-146-1	Switch - Toggle . . . . .	1
28	WL-14-7	Lock Washer - #10 Ext. Shakeproof . . . . .	1
29	SD-19-13	Self-Tapping Screw - #10 x 3/8" Rd. Hd., Type B . . . . .	6
30	FE-21-12	Plug - 1/2" (7/8" Dia. Hole) . . . . .	1
31	SC-41-12	Cap Screw - 5/16"-18 x 7/8" Hex Hd . . . . .	4
32	WS-17-8	Washer . . . . .	4
33	NS-32-35	Stop Nut - 5/16"-18 "Flexloc" . . . . .	4

\*Elec. Dryer.

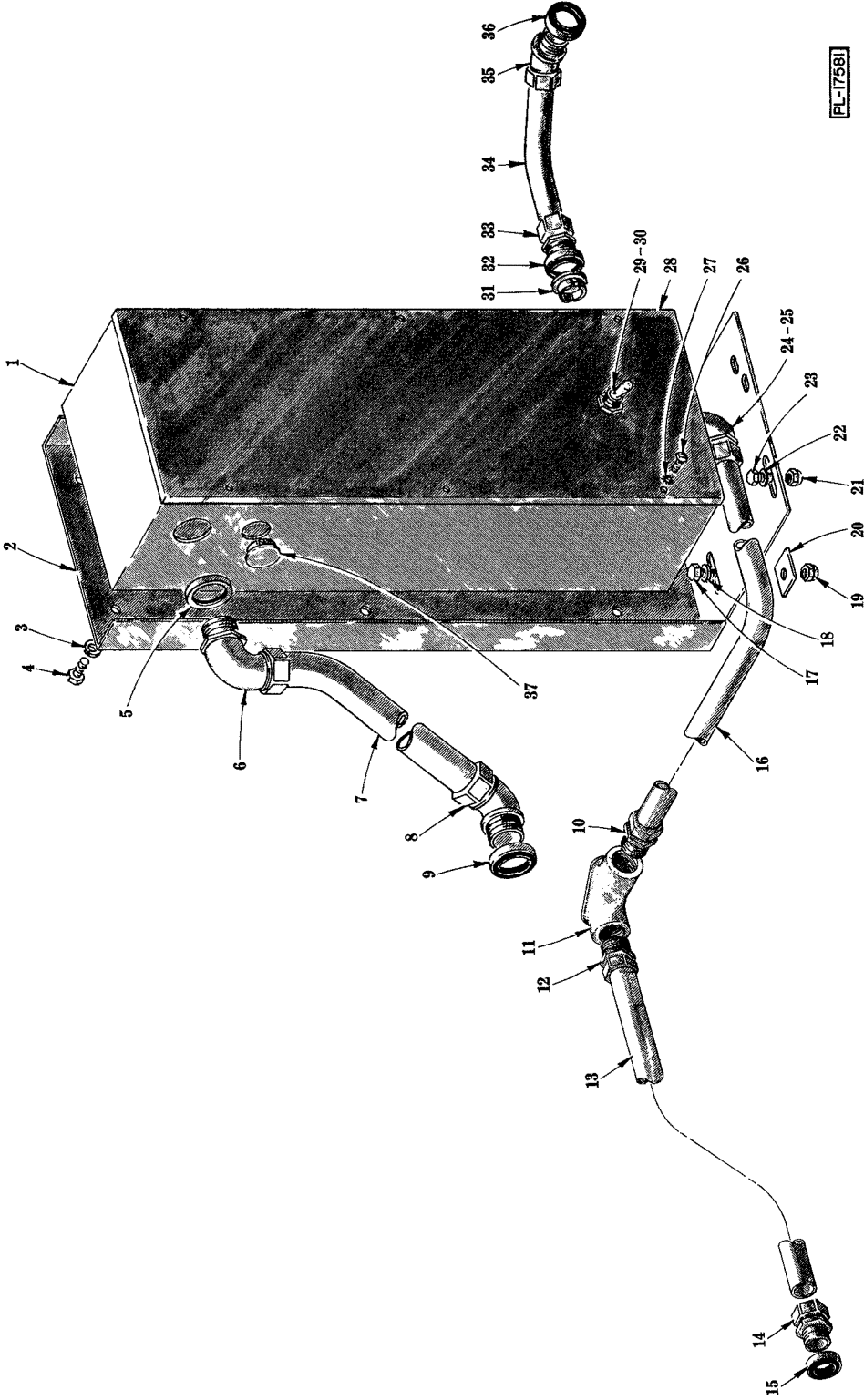

DRYER CONTROL BOX AND CONDUIT

**DRYER CONTROL BOX AND CONDUIT  
(L. TO R. OPERATION)**

ILLUS. PL-17581	PART NO.	NAME OF PART	AMT.
1	C-123073	Dryer Control Box Assy . . . . .	1
2	D-121205	Bracket - Dryer Control Box . . . . .	1
3	WL-6-16	Lock Washer - 1/4" Light . . . . .	6
4	SC-41-50	Cap Screw - 1/4"-20 x 1/2" Hex Hd . . . . .	6
5	FE-8-11	3/4" Gasket Assy . . . . .	1
6	FE-8-25	Connector - 90° "Sealtite" (3/4" Male Thd. x 3/4" Flex. Cnd.) . . . . .	1
7	P-77657-36	Conduit - 3/4" x 6" (Waterproof) . . . . .	1
8	FE-8-24	Connector - 45° "Sealtite" (3/4" Male Thd. x 3/4" Flex. Cnd.) . . . . .	1
9	FE-8-11	3/4" Gasket Assy . . . . .	1
10	FE-6-45	Connector - Straight (1/2" Male Thd. x 1/2" Thinwall) . . . . .	1
11	FE-7-31	Ell - 90° x 1/2" Pulling . . . . .	1
12	FE-6-45	Connector - Straight (1/2" Male Thd. x 1/2" Thinwall) . . . . .	1
13	C-276838	Conduit - Blower/Dryer . . . . .	1
14	M-83294	Connector - Straight (1/2" Male Thd. x 1/2" Thinwall) . . . . .	1
15	FE-8-10	1/2" Gasket Assy . . . . .	1
16	C-89740-75	Conduit - Blower/Dryer . . . . .	1
17	SC-41-12	Cap Screw - 5/16"-18 x 7/8" Hex Hd . . . . .	2
18	WS-17-8	Washer . . . . .	2
19	NS-32-35	Stop Nut - 5/16"-18 "Flexloc" . . . . .	2
20	A-121204	Shim - Control Box . . . . .	2
21	NS-32-35	Stop Nut - 5/16"-18 "Flexloc" . . . . .	2
22	WS-17-8	Washer . . . . .	2
23	SC-41-12	Cap Screw - 5/16"-18 x 7/8" Hex Hd . . . . .	2
24	FE-6-37	Ell - 90° Short (1/2" Male Thd. x 1/2" Thinwall) . . . . .	1
25	FE-8-10	1/2" Gasket Assy . . . . .	1
26	SD-19-13	Self-Tapping Screw - #10 x 3/8" Rd. Hd., Type B . . . . .	6
27	WL-14-7	Lock Washer - #10 Ext. Shakeproof . . . . .	1
28	D-123072	Cover - Control Box . . . . .	1
29	B-87711-146-1	Switch - Toggle . . . . .	1
30	WL-8-32	Lock Washer - 1/2" Int. Shakeproof . . . . .	1
31	FE-21-12	Plug - 1/2" (7/8" Dia. Hole) (Steam Dryer ONLY) . . . . .	1
*32	FE-8-10	1/2" Gasket Assy . . . . .	1
*33	FE-6-45	Connector - Straight (1/2" Male Thd. x 1/2" Thinwall) . . . . .	1
*34	C-89740-72	Conduit - 1/2" Thinwall (Control Box to Wiring Channel) . . . . .	1
*35	FE-8-45	Connector - 45° (1/2" Male Thd. x 1/2" Thinwall) . . . . .	1
*36	FE-8-10	1/2" Gasket Assy . . . . .	1
37	FE-21-12	Plug - 1/2" (7/8" Dia. Hole) . . . . .	1

\*Elec. Dryer.

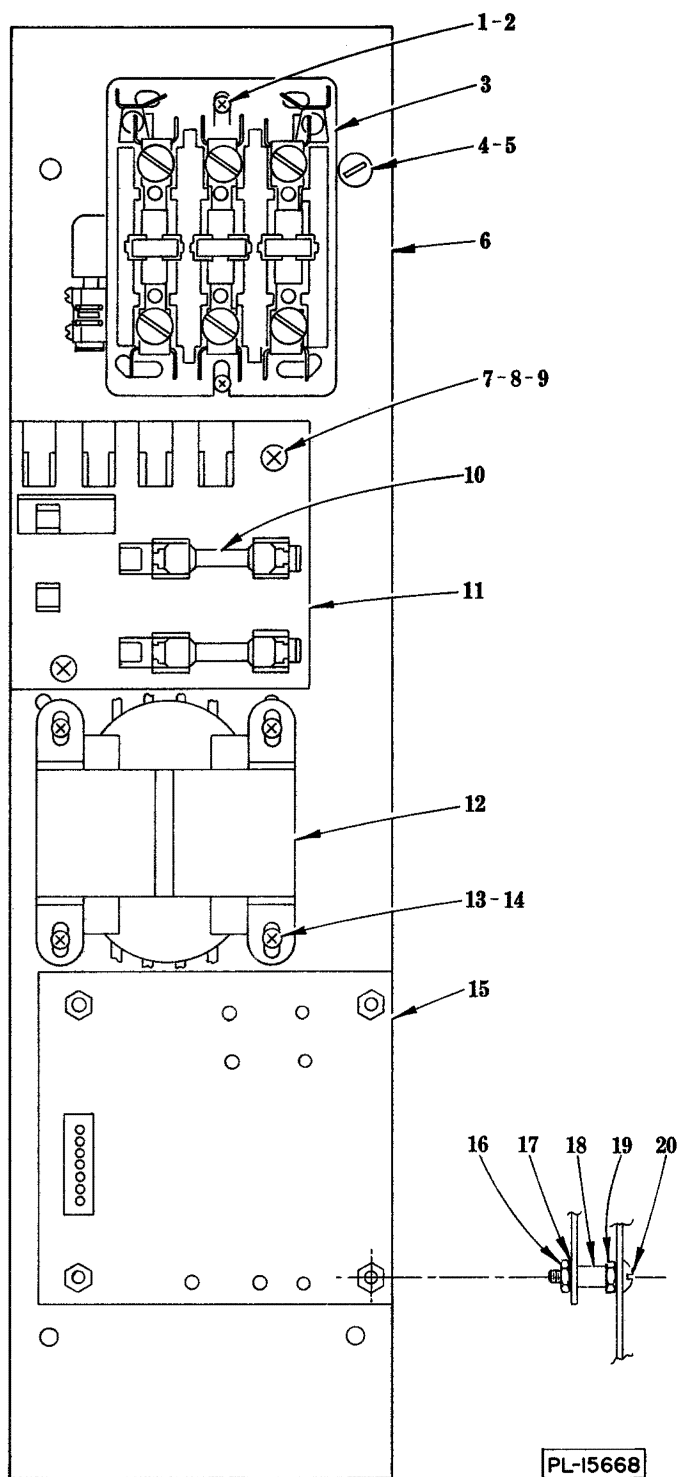

CONTROL PANEL  
(BLOWER DRYER)

**CONTROL PANEL  
(BLOWER DRYER)**

ILLUS. PL-15668	PART NO.	NAME OF PART	AMT.
1	SD-8-25	Self-Tapping Screw - #10 x 3/8" Phil. Bind Hd., Type B . . . . .	2
2	WL-14-7	Lock Washer - #10 Ext. Shakeproof . . . . .	2
3	B-121926-2	Contactora - Magnetic (3 Ph.) . . . . .	1
4	SC-21-22	Mach. Screw - #10-24 x 3/8" Rd. Hd . . . . .	4
5	WL-6-7	Lock Washer - #10 Medium . . . . .	4
6	D-121226	Panel - Control . . . . .	1
7	SD-9-39	Self-Tapping Screw - #8-32 x 3/8" Phil. Pan Hd., Type F . . . . .	2
8	WL-14-5	Lock Washer - #8 Ext. Shakeproof . . . . .	2
9	WS-23-44	Washer . . . . .	2
10	FE-19-48	Fuse - Fiber Tube (.8 Amp. BBS-.8) . . . . .	2
11	C-114707	Terminals & Mounting Board Assy . . . . .	1
12	C-111983-2	Power Input Board Assy. (3 Ph.) . . . . .	1
13	SD-8-25	Self-Tapping Screw - #10 x 3/8" Phil. Bind Hd., Type B . . . . .	4
14	WL-14-7	Lock Washer - #10 Ext. Shakeproof . . . . .	4
15	E-278328	Motor Proector Board Assy . . . . .	1
16	NS-9-8	Mach. Nut - #6-32 Hex . . . . .	4
17	WL-6-42	Lock Washer - #6 Medium . . . . .	4
18	B-119994	Spacer - Motor Protector Board . . . . .	4
19	NS-9-8	Mach. Nut - #6-32 Hex . . . . .	4
20	SD-29-11	Self-Tapping Screw - #6-32 x 1" Phil. Pan Hd., Type F . . . . .	4

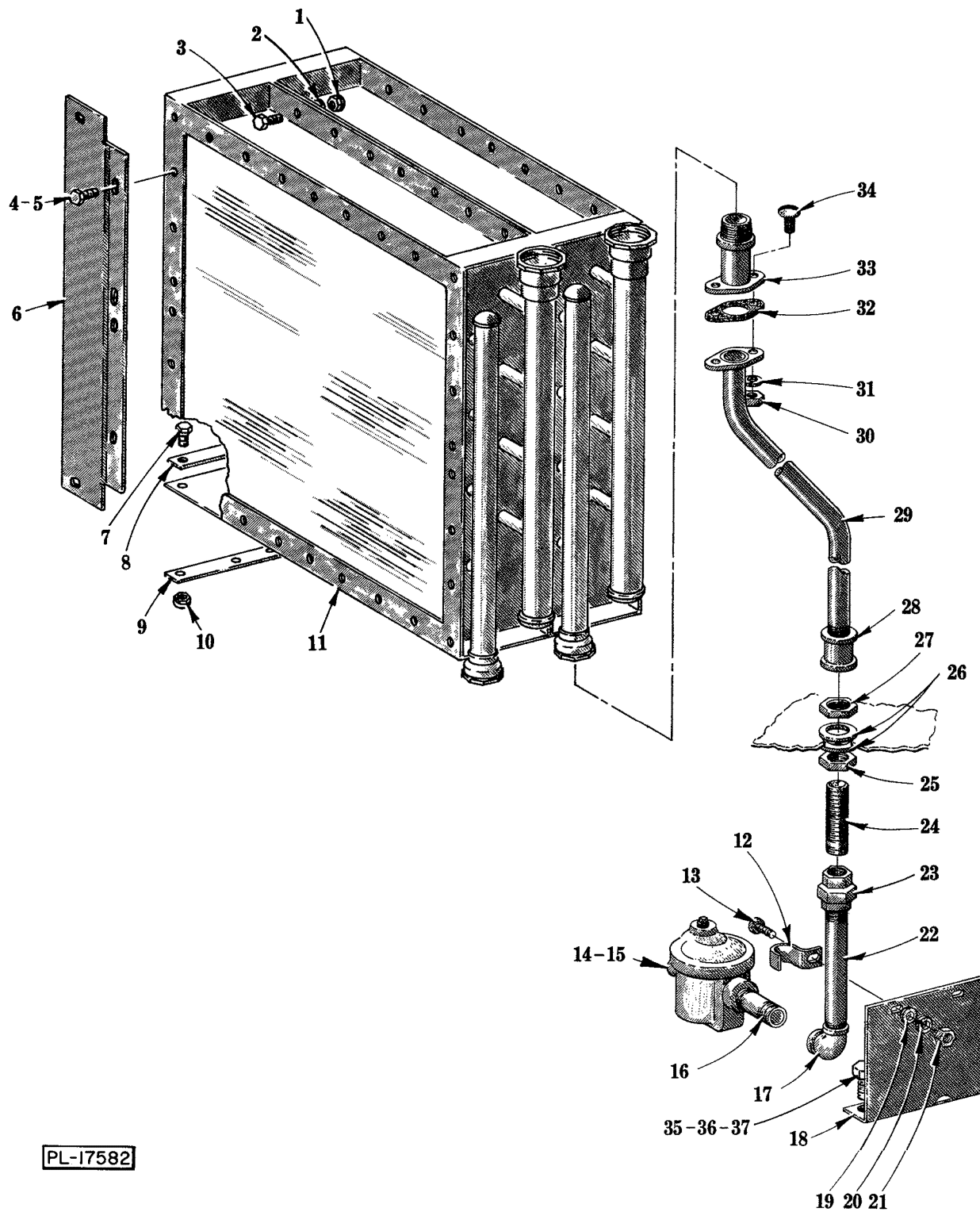

STEAM HEATER  
(BLOWER DRYER)

**STEAM HEATER  
(BLOWER DRYER)**

ILLUS. PL-17582	PART NO.	NAME OF PART	AMT.
1	NS-31-19	Stop Nut - 1/4"-20 "Elastic"	15
2	WS-3-43	Washer	15
3	SC-41-5	Cap Screw - 1/4"-20 x 3/4" Hex Hd	15
4	SC-41-5	Cap Screw - 1/4"-20 x 3/4" Hex Hd	4
5	NS-31-19	Stop Nut - 1/4"-20 "Elastic"	4
6	C-119607	Baffle - Steam	1
7	SC-41-12	Cap Screw - 5/16"-18 x 7/8" Hex Hd	8
8	B-123052	Bracket - Coil	4
9	B-121102	Shim - Coils	1
10	NS-32-35	Stop Nut - 5/16"-18 "Flexloc"	8
11	S-89751	Coil - Steam	2
12	FE-6-48	Clamp - Pipe	2
13	SC-8-10	Mach. Screw - #10-24 x 1/2" Rd. Hd	2
14	C-118316	Trap - Steam (0-20 P.S.I.)	2
15	C-118317	Trap - Steam (21-50 P.S.I.)	2
16	FP-35-98	Nipple - 3/4" x 3-1/4" Lg. (T.B.E.)	2
17	FP-13-22	Elbow - 3/4" x 90°	2
18	D-277624	Bracket - Condensate Pipe	1
19	WS-19-6	Washer	2
20	WL-3-20	Lock Washer - #10 Light	2
21	NS-9-22	Mach. Nut - #10-24 Hex	2
22	FP-77-46	Nipple - 3/4" x 7-3/16" Lg. (T.B.E.)	1
23	FP-22-17	Union - 3/4" (Grd. Seat)	2
24	FP-77-45	Nipple - 3/4" x 4" Lg. (T.B.E., R.T.O.E. 3-1/4" Lg. )	1
25	FP-53-9	Lock Nut - 3/4" Pipe	2
26	WS-13-45	Washer	4
27	FP-53-9	Lock Nut - 3/4" Pipe	2
28	FP-57-15	Coupling - 3/4" Pipe	1
29	D-287521-1	Condensate Pipe Assy	2
30	NS-15-11	Full Nut - 5/16"-18 Hex Fin	4
31	WL-6-22	Lock Washer - 5/16" Light	4
32	B-287523	Gasket - Condensate Pipe	2
33	B-287522-1	Condensate Pipe Assy	2
34	SC-41-11	Cap Screw - 5/16"-18 x 3/4" Hex Hd	4
35	SC-41-10	Cap Screw - 5/16"-18 x 5/8" Hex Hd	2
36	WS-17-8	Washer	2
37	NS-31-29	Stop Nut - 5/16"-18 "Elastic"	2

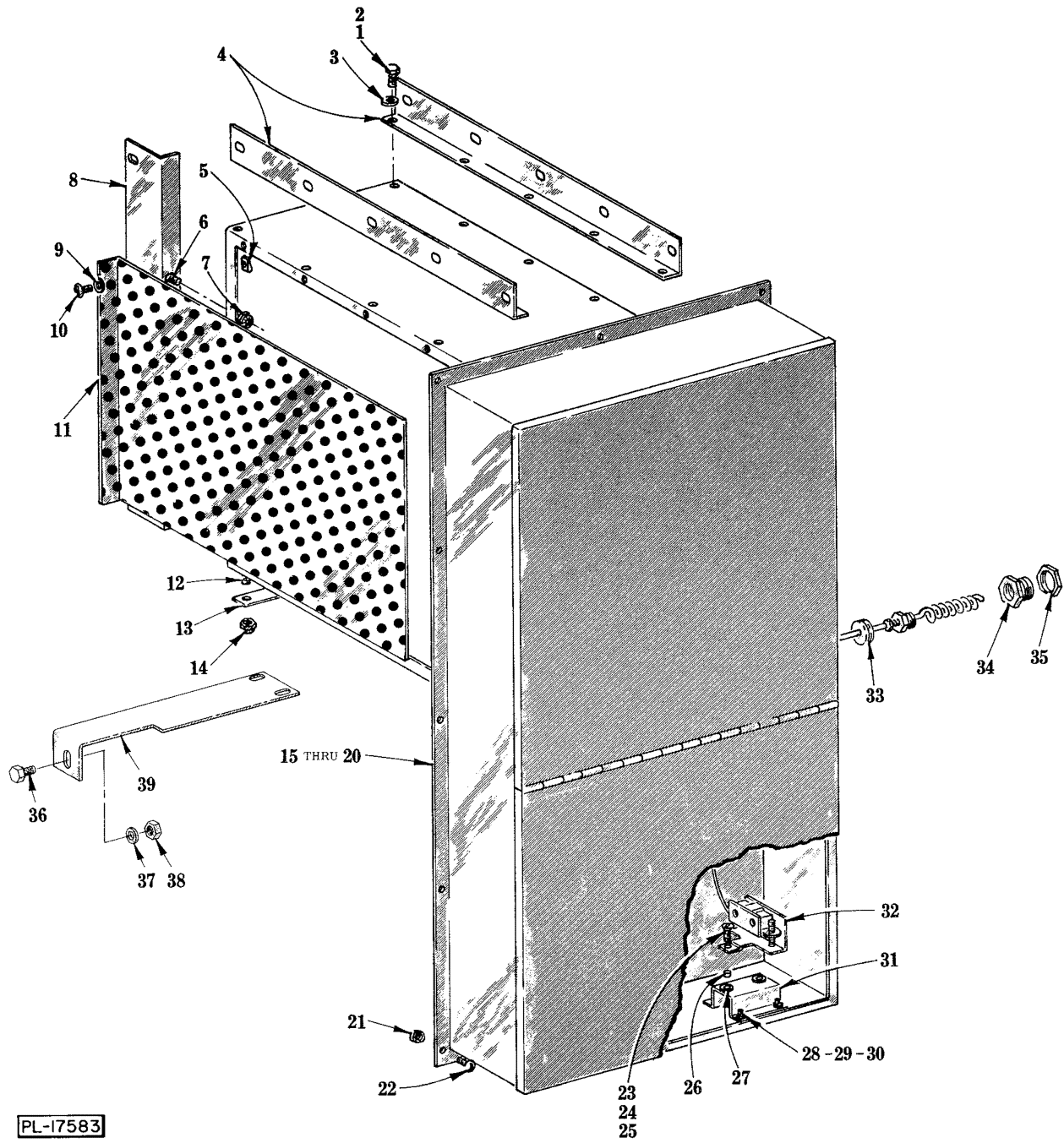

**ELECTRIC HEATER  
(BLOWER DRYER)**

**ELECTRIC HEATER  
(BLOWER DRYER)**

ILLUS. PL-17583	PART NO.	NAME OF PART	AMT.
1	SC-41-5	Cap Screw - 1/4"-20 x 5/8" Hex Hd	10
2	NS-31-19	Stop Nut - 1/4"-20 "Elastic"	10
3	WS-3-43	Washer	10
4	D-119500	Baffle - Elec. Dryer	2
5	M-74348	Speed Nut - #10-24	4
6	SC-41-1	Cap Screw - 1/4"-20 x 3/4" Hex Hd	2
7	NS-31-19	Stop Nut - 1/4"-20 "Elastic"	2
8	C-120954	Baffle - Dryer Side	1
9	WS-29-10	Washer	4
10	SC-53-5	Mach. Screw - #10-24 x 3/8" Truss Hd	4
11	C-113073	Screen - Air	1
12	SC-41-12	Cap Screw - 5/16"-18 x 7/8" Hex Hd	4
13	B-121102	Shim - Coils	1
14	NS-32-35	Stop Nut - 5/16"-18 "Flexloc"	4
15	E-112829-2	Heater - Air Duct (42 KW) (200 V., 60 Hz., 3 Ph.) (W/Terminal Block)	1
16	E-112829-12	Heater - Air Duct (42 KW) (200 V., 60 Hz., 3 Ph.) (W/Circuit Breaker)	1
17	E-112829-3	Heater - Air Duct (42 KW) (460 V., 60 Hz., 3 Ph.) (W/Terminal Block)	1
18	E-112829-13	Heater - Air Duct (42 KW) (460 V., 60 Hz., 3 Ph.) (W/Circuit Breaker)	1
19	E-112829-5	Heater - Air Duct (42 KW) (230 V., 60 Hz., 3 Ph.) (W/Terminal Block)	1
20	E-112829-15	Heater - Air Duct (42 KW) (230 V., 60 Hz., 3 Ph.) (W/Circuit Breaker)	1
21	NS-31-15	Stop Nut - #10-24 "Elastic"	12
22	SC-53-2	Mach. Screw - #10-24 x 1/2" Truss Hd	12
23	SC-12-36	Mach. Screw - #10-24 x 3/4" Fil. Hd	2
24	WL-3-20	Lock Washer - #10 Light	2
25	NS-9-22	Mach. Nut - #10-24 Hex	2
26	V-23450	Spacer - Solenoid	2
27	V-23458	Grommet	2
28	SC-53-35	Mach. Screw - #8-32 x 3/8" Truss Hd	4
29	WL-6-1	Lock Washer - #8 Light	4
30	NS-11-12	Mach. Nut - #8-32 Hex	4
31	C-114200	Support - Thermostat	1
32	C-277244-1	Thermostat	1
33	M-65028	Grommet	1
34	P-79531	Adapter - Tank (Thermostat Bulb)	1
35	FP-30-16	Lock Nut - 1/2" Pipe	1
36	SC-41-5	Cap Screw - 1/4"-20 x 5/8" Hex Hd	2
37	WS-3-43	Washer	2
38	NS-31-19	Stop Nut - 1/4"-20 "Elastic"	2
39	C-287057-2	Bracket - Sealing (R. to L.)	1
40	C-287057-1	Bracket - Sealing (L. to R.)	1

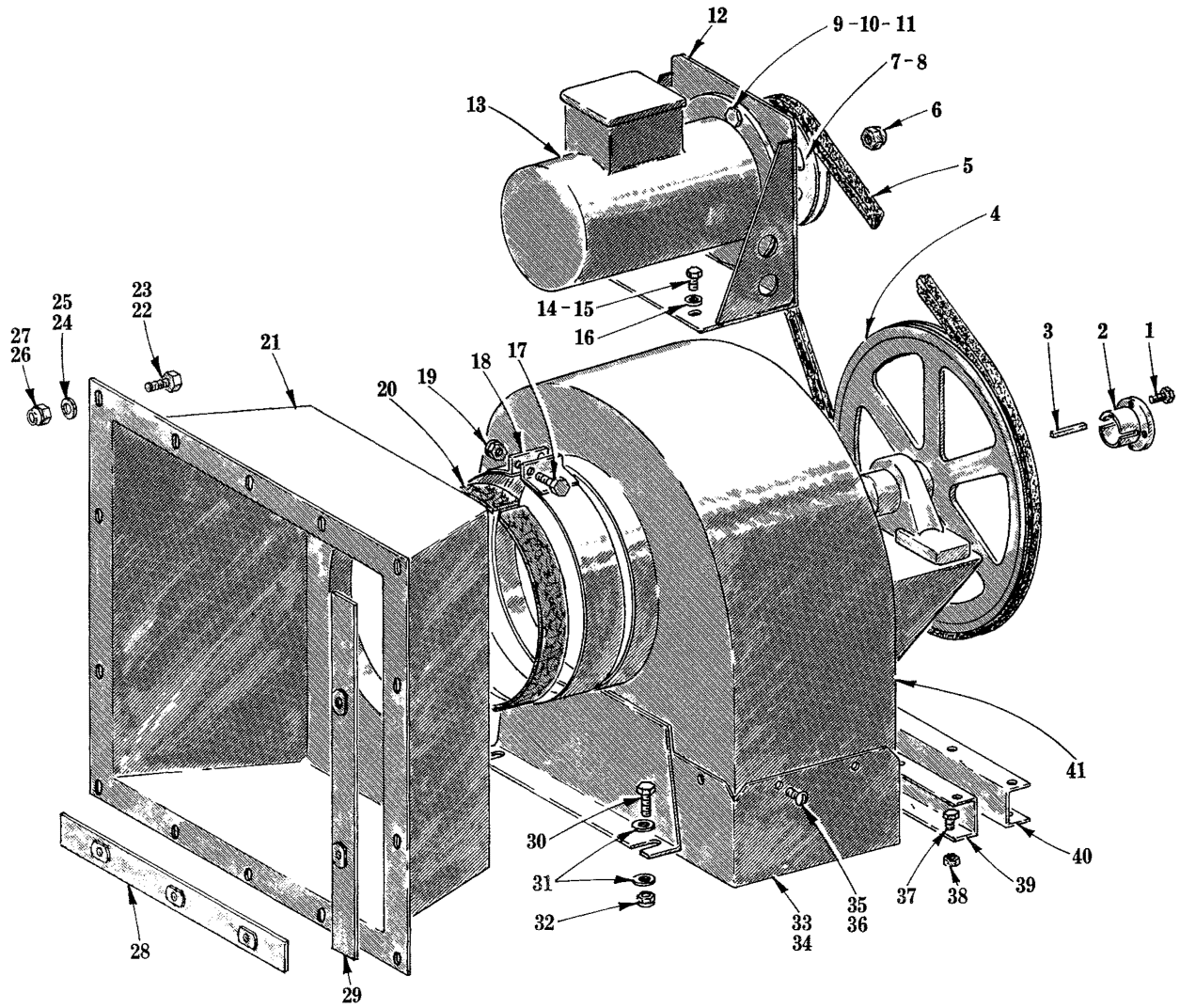

PL-17584

BLOWER

## BLOWER

ILLUS. PL-17584	PART NO.	NAME OF PART	AMT.
1	SC-37-87	Cap Screw - 1/4"-20 x 1" Hex Hd . . . . .	2
2	M-83605	Hub - Driven Sheave . . . . .	1
3	M-83547	Key . . . . .	1
4	P-62202-5	Sheave - Fan . . . . .	1
5	BV-13-1	"V" Belt . . . . .	1
6	NS-24-6	Acorn Nut - 7/16"-20 . . . . .	1
7	P-84882	Motor Sheave & Bushing Assy . . . . .	1
8	KW-3-3	Key - #404 Woodruff . . . . .	1
9	SC-41-29	Cap Screw - 3/8"-16 x 7/8" Hex Hd . . . . .	2
10	WL-6-28	Lock Washer - 3/8" Medium . . . . .	2
11	NS-15-13	Full Nut - 3/8"-16 Hex Fin . . . . .	2
12	C-276612	Motor Bracket Assy . . . . .	1
13	ML-34229	Motor (Give Elec. Spec.) . . . . .	1
14	SC-41-13	Cap Screw - 5/16"-18 x 1" Hex Hd . . . . .	4
15	NS-31-29	Stop Nut - 5/16"-18 "Elastic" . . . . .	4
16	WS-5-32	Washer . . . . .	8
17	SC-41-13	Cap Screw - 5/16"-18 x 1" Hex Hd . . . . .	2
18	P-84865	Clamp Assy . . . . .	1
19	NS-31-29	Stop Nut - 5/16"-18 "Elastic" . . . . .	2
20	P-67976-3	Gasket - Clamp . . . . .	1
21	E-118810	Blower Intake Assy . . . . .	1
22	SC-41-5	Cap Screw - 1/4"-20 x 5/8" Hex Hd. (Steam Dryer) . . . . .	14
23	SC-41-5	Cap Screw - 1/4"-20 x 5/8" Hex Hd. (Electric Dryer) . . . . .	12
24	WS-3-43	Washer (Steam Dryer) . . . . .	14
25	WS-3-43	Washer (Electric Dryer) . . . . .	12
26	NS-31-19	Stop Nut - 1/4"-20 "Elastic" (Steam Dryer) . . . . .	14
27	NS-31-19	Stop Nut - 1/4"-20 "Elastic" (Electric Dryer) . . . . .	7
28	C-277212-1	Blower Intake Support Assy. (Electric Dryer) . . . . .	1
29	C-277213-1	Blower Intake Support Assy. (Electric Dryer) . . . . .	1
30	SC-41-30	Cap Screw - 3/8"-16 x 1" Hex Hd . . . . .	4
31	WS-18-37	Washer . . . . .	8
32	NS-31-33	Stop Nut - 3/8"-16 "Elastic" . . . . .	4
33	P-84878-1	Fan Duct Assy. (Steam Dryer) . . . . .	1
34	P-84878-2	Fan Duct Assy. (Electric Dryer) . . . . .	1
35	SC-53-2	Mach. Screw - #10-24 x 1/2" Truss Hd . . . . .	6
36	NS-31-15	Stop Nut - #10-24 "Elastic" . . . . .	6
37	SC-41-11	Cap Screw - 5/16"-18 x 3/4" Hex Hd . . . . .	4
38	NS-31-29	Stop Nut - 5/16"-18 "Elastic" . . . . .	4
39	R-84859-3	Base - Motor (R.H.) . . . . .	1
40	R-84859-4	Base - Motor (L.H.) . . . . .	1
41	E-112824	Fan Assy . . . . .	1

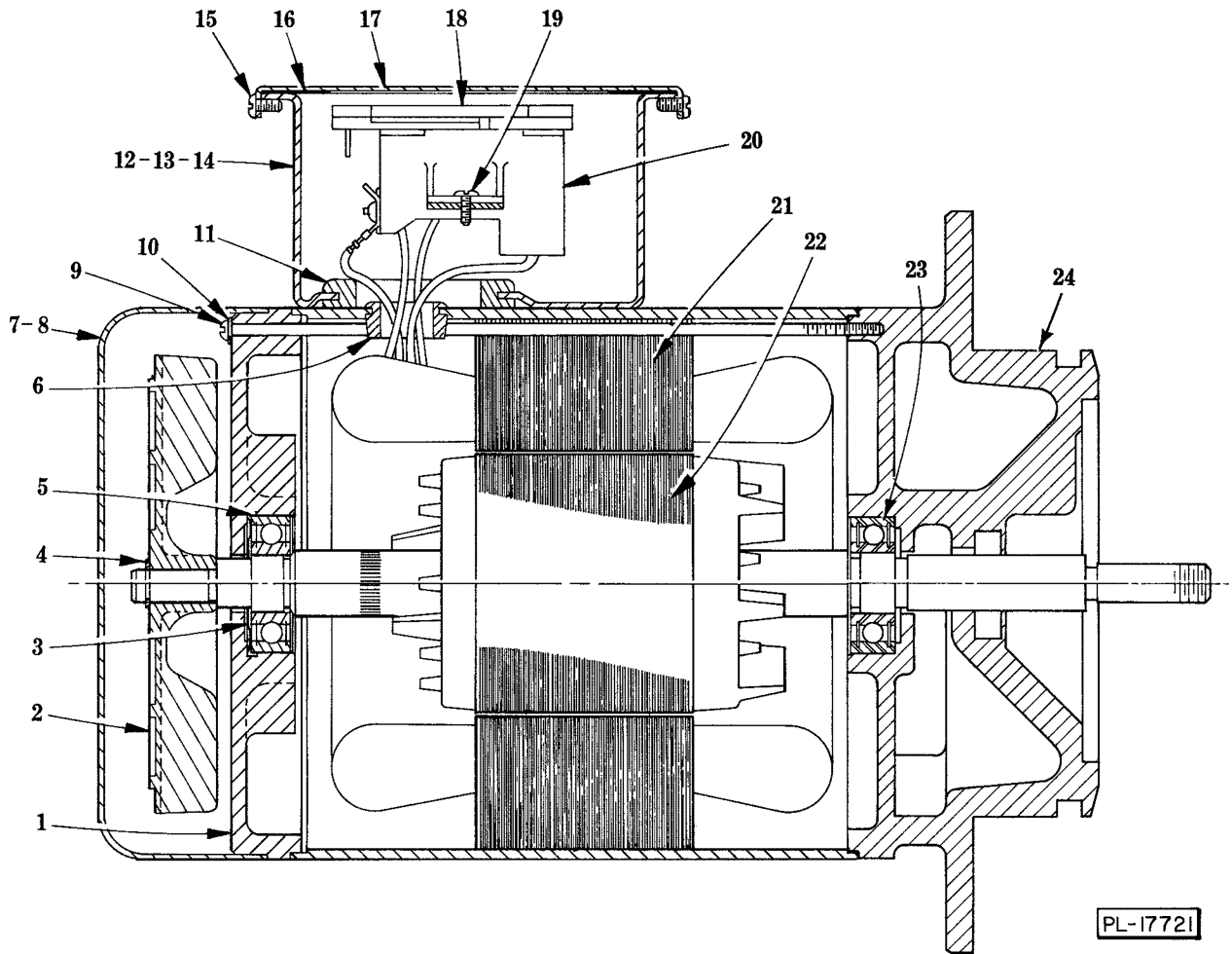

MOTOR UNIT

## MOTOR UNIT

ILLUS. PL-17721	PART NO.	NAME OF PART	AMT.
1	D-114379-2	Bracket - Bearing (Fan End)	1
2	D-111493-1	Fan - Ventilating	1
3	SL-2-4	Loading Spring - N.D. #S-17	1
4	RR-4-17	Retaining Ring	1
5	BB-20-18	Ball Bearing - N.D. #77503	1
6	M-79118	Bushing - Snap	1
7	R-77067	Cover - Motor End	1
8	SC-9-65	Mach. Screw - #8-32 x 1/4" Rd. Hd	2
9	SC-60-68	Mach. Screw - #10-24 x 7-1/2" Rd. Hd	4
10	WL-8-13	Lock Washer - #10 Int. Shakeproof	4
11	M-60395	Grommet	1
12	D-113403	Box - Terminal	1
13	SD-15-27	Self-Tapping Screw - #10-24 x 5/16" Pan Hd. "Taptite"	2
14	WL-7-12	Lock Washer - #10 Ext. Shakeproof	2
15	SD-12-45	Self-Tapping Screw - #8-32 x 5/16" Pan Hd., Type 23	2
16	B-114811	Gasket - Terminal Box	1
17	C-113405	Cover - Terminal Box	1
18	C-113417	Connector Block Assy	1
19	SD-12-45	Self-Tapping Screw - #8-32 x 5/16" Pan Hd., Type 23	2
20	C-113552	Terminal Block Base Assy	1
21	D-65478-101-1	Stator Assy	1
22	C-15747-280	Rotor Assy	1
23	BB-20-18	Ball Bearing - N.D. #77503	1
24	E-121191-2	Bracket - Bearing	1

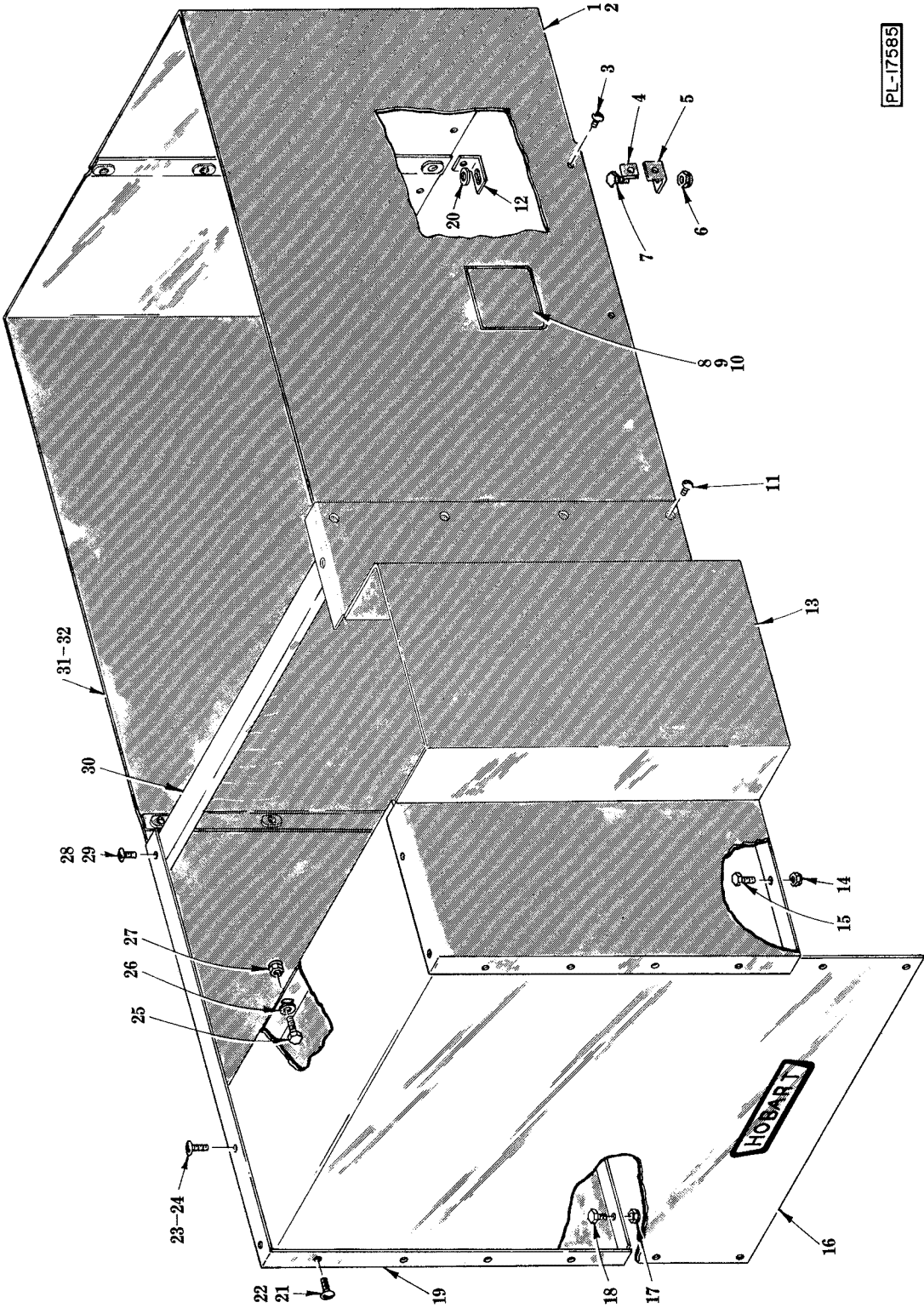

PL-17565

PANELS

**PANELS  
(STEAM DRYER)**

ILLUS. PL-17585	PART NO.	NAME OF PART	AMT.
1	E-276841-3	Blower Motor Cover Assy. (Front) (R. to L.) . . . . .	1
2	E-276841-1	Blower Motor Cover Assy. (Front) (L. to R.) (Not Shown) . . . . .	1
3	SC-53-2	Mach. Screw - #10-24 x 1/2" Truss Hd . . . . .	6
4	M-74348	Speed Nut - #10-24 . . . . .	6
5	M-83521	Bracket - Blower Motor Cover . . . . .	4
6	NS-32-35	Stop Nut - 5/16"-18 "Flexloc" . . . . .	4
7	SC-41-11	Cap Screw - 5/16"-18 x 3/4" Hex Hd . . . . .	4
8	C-123079-1	Access Door Assy . . . . .	1
9	M-67177	Hinge . . . . .	1
10	NS-31-15	Stop Nut - #10-24 "Elastic" . . . . .	4
11	SC-53-2	Mach. Screw - #10-24 x 1/2" Truss Hd . . . . .	12
12	C-276840	Bracket - Panel . . . . .	2
13	E-277632-1	Cover - Steam Dryer (Front) . . . . .	1
14	NS-32-35	Stop Nut - 5/16"-18 "Flexloc" . . . . .	4
15	SC-41-11	Cap Screw - 5/16"-18 x 3/4" Hex Hd . . . . .	4
16	E-119496	Cover - Dryer Coil Top . . . . .	1
17	NS-32-35	Stop Nut - 5/16"-18 "Flexloc" . . . . .	4
18	SC-41-11	Cap Screw - 5/16"-18 x 3/4" Hex Hd . . . . .	4
19	E-277284-2	Cover - Dryer (Rear) . . . . .	1
20	WS-19-6	Washer . . . . .	2
21	SC-53-17	Mach. Screw - 5/16"-18 x 3/4" Truss Hd . . . . .	8
22	NS-32-35	Stop Nut - 5/16"-18 "Flexloc" . . . . .	8
23	SC-53-17	Mach. Screw - 5/16"-18 x 3/4" Truss Hd . . . . .	4
24	NS-32-35	Stop Nut - 5/16"-18 "Flexloc" . . . . .	4
25	SC-41-5	Cap Screw - 1/4"-20 x 5/8" Hex Hd . . . . .	6
26	WS-3-43	Washer . . . . .	6
27	NS-31-19	Stop Nut - 1/4"-20 "Elastic" . . . . .	6
28	SC-53-17	Mach. Screw - 5/16"-18 x 3/4" Truss Hd . . . . .	2
29	NS-32-35	Stop Nut - 5/16"-18 "Flexloc" . . . . .	2
30	P-83606-2	Tie - Coil Cover . . . . .	1
31	E-276842-1	Blower Motor Cover Assy. (Rear) (R. to L.) . . . . .	1
32	E-276842-3	Blower Motor Cover Assy. (Rear) (L. to R.) (Not Shown) . . . . .	1

PL-17586

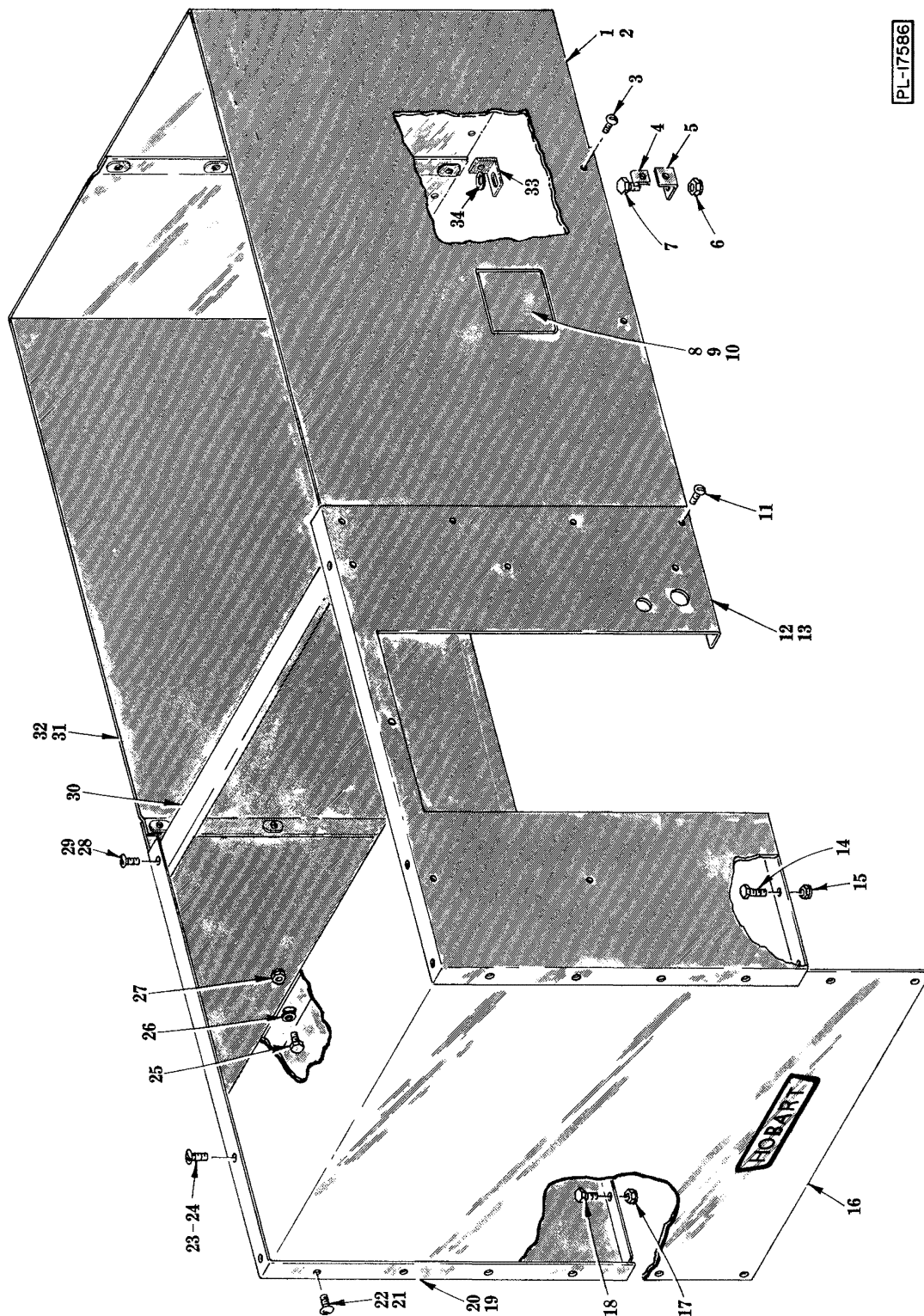

PANELS

**PANELS  
(ELECTRIC DRYER)**

ILLUS. PL-17586	PART NO.	NAME OF PART	AMT.
1	E-276841-3	Blower Motor Cover Assy. (Front) (R. to L.) . . . . .	1
2	E-276841-1	Blower Motor Cover Assy. (Front) (L. to R.) (Not Shown) . . . . .	1
3	SC-53-2	Mach. Screw - #10-24 x 1/2" Truss Hd . . . . .	6
4	M-74348	Speed Nut - #10-24 . . . . .	6
5	M-83521	Bracket - Blower Motor Cover . . . . .	4
6	NS-32-35	Stop Nut - 5/16"-18 "Flexloc" . . . . .	4
7	SC-41-11	Cap Screw - 5/16"-18 x 3/4" Hex Hd . . . . .	4
8	C-123079-1	Access Door Assy . . . . .	1
9	M-67177	Hinge . . . . .	1
10	NS-31-15	Stop Nut - #10-24 "Elastic" . . . . .	4
11	SC-53-2	Mach. Screw - #10-24 x 1/2" Truss Hd . . . . .	12
12	E-277283-2	Cover - Electric Dryer (Front) (R. to L.) . . . . .	1
13	E-277283-1	Cover - Electric Dryer (Front) (L. to R.) (Not Shown) . . . . .	1
14	SC-41-11	Cap Screw - 5/16"-18 x 3/4" Hex Hd . . . . .	4
15	NS-32-35	Stop Nut - 5/16"-18 "Flexloc" . . . . .	4
16	E-119496	Cover - Dryer Coil Top . . . . .	1
17	NS-32-35	Stop Nut - 5/16"-18 "Flexloc" . . . . .	4
18	SC-41-11	Cap Screw - 5/16"-18 x 3/4" Hex Hd . . . . .	4
19	E-277284-2	Cover - Dryer (Rear) (R. to L.) . . . . .	1
20	E-277284-1	Cover - Dryer (Rear) (L. to R.) (Not Shown) . . . . .	1
21	SC-53-17	Mach. Screw - 5/16"-18 x 3/4" Truss Hd . . . . .	8
22	NS-32-35	Stop Nut - 5/16"-18 "Flexloc" . . . . .	8
23	SC-53-17	Mach. Screw - 5/16"-18 x 3/4" Truss Hd . . . . .	4
24	NS-32-35	Stop Nut - 5/16"-18 "Flexloc" . . . . .	4
25	SC-41-5	Cap Screw - 1/4"-20 x 5/8" Hex Hd . . . . .	6
26	WS-3-43	Washer . . . . .	6
27	NS-31-19	Stop Nut - 1/4"-20 "Elastic" . . . . .	6
28	SC-53-17	Mach. Screw - 5/16"-18 x 3/4" Truss Hd . . . . .	2
29	NS-32-35	Stop Nut - 5/16"-18 "Flexloc" . . . . .	2
30	P-83606-2	Tie - Coil Cover . . . . .	1
31	E-276842-1	Blower Motor Cover Assy. (Rear) (R. to L.) . . . . .	1
32	E-276842-3	Blower Motor Cover Assy. (Rear) (L. to R.) (Not Shown) . . . . .	1
33	C-276840	Bracket - Panel . . . . .	2
34	WS-19-6	Washer . . . . .	2

**96 DISCHARGE REPLACEMENT PARTS**

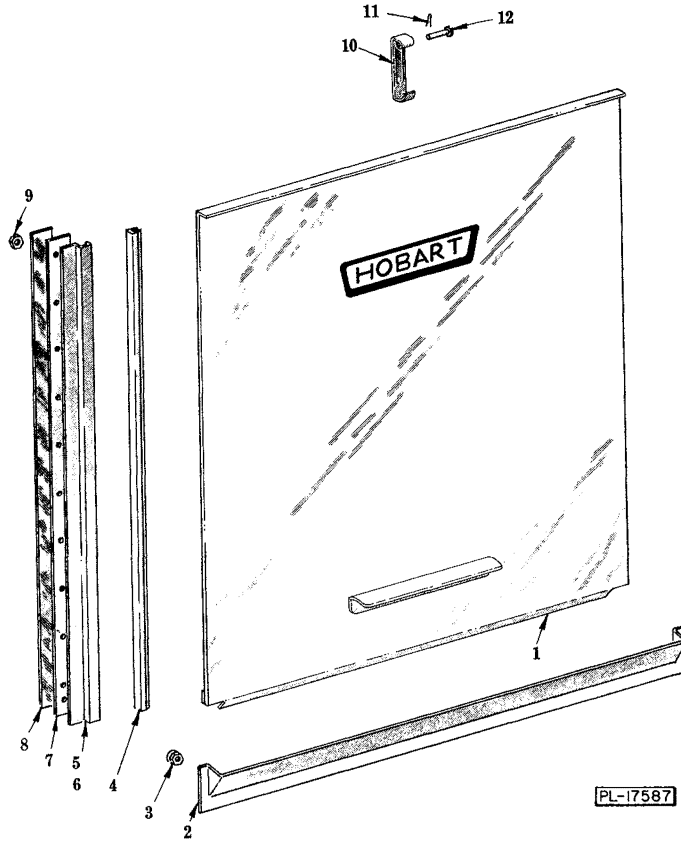

**DRYER DOOR  
(2 UNITS REQUIRED)**

ILLUS. PL-17587	PART NO.	NAME OF PART	AMT. (Per Unit)
1	C-112446	Door & Lift Handle Assy . . . . .	1
2	C-156584	Inspection Door Trough Assy . . . . .	1
3	NS-31-16	Stop Nut - #10-24 "Elastic" . . . . .	11
4	D-112378-11	Slide - Door . . . . .	2
5	D-112383-1	Door Guide Assy. (L.H.) . . . . .	1
6	D-112384-1	Door Guide Assy. (R.H.) (Not Shown) . . . . .	1
7	C-112491	Spacer - Door Guide . . . . .	2
8	526454	Tape - Foam . . . . .	AR
9	NS-31-16	Stop Nut - #10-24 "Elastic" . . . . .	22
10	C-290164	Latch - Door . . . . .	1
11	PC-5-2	Cotter Pin - 1/16" x 1/2" . . . . .	1
12	V-12114	Pin . . . . .	1