

INSTRUCTIONS

HC24EO SERIES STEAMER

MODEL

ML

HC24EO3

ML-136006

HC24EO5

ML-136007



www.energystar.gov

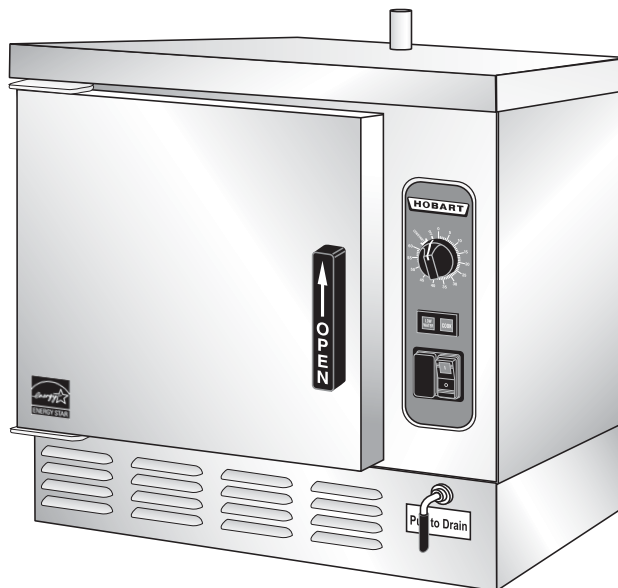

HOBART

701 S. RIDGE AVENUE
TROY, OHIO 45374-0001

937 332-3000

www.hobartcorp.com

FORM 37491 (May 2010)

IMPORTANT FOR YOUR SAFETY

THIS MANUAL HAS BEEN PREPARED FOR PERSONNEL QUALIFIED TO INSTALL THIS EQUIPMENT, WHO SHOULD PERFORM THE INITIAL FIELD START-UP AND ADJUSTMENTS OF THE EQUIPMENT COVERED BY THIS MANUAL.

▲ WARNING

IMPROPER INSTALLATION, ADJUSTMENT, ALTERATION, SERVICE OR MAINTENANCE CAN CAUSE PROPERTY DAMAGE, INJURY OR DEATH. READ THE INSTALLATION, OPERATING AND MAINTENANCE INSTRUCTIONS THOROUGHLY BEFORE INSTALLING OR SERVICING THIS EQUIPMENT.

IN THE EVENT OF A POWER FAILURE, DO NOT ATTEMPT TO OPERATE THIS DEVICE.

TABLE OF CONTENTS

INSTALLATION, OPERATION AND CARE OF MODEL HC24EO SERIES STEAMERS	5
GENERAL.....	5
INSTALLATION.....	5
UNPACKING.....	5
INSTALLATION CODES AND STANDARDS	5
LOCATION.....	5
LEVELING FEET	6
LEVELING	6
ANCHORING STEAMER	6
STACKING STAND.....	6
ELECTRICAL CONNECTIONS	7
ELECTRICAL DATA.....	8
SERVICE CONNECTIONS	8
Water Connections	8
Water Treatment	8
Water Requirements	8
Drain Connection	8
VENT HOOD	9
INSTALLATION STARTUP PROCEDURE	9
Calibration Procedure	10
OPERATION.....	12
CONTROLS.....	12
OPERATING THE STEAMER	12
LOW WATER.....	12
SHUTDOWN	13
EXTENDED SHUTDOWN.....	13
CLEANING	14
COOKING COMPARTMENT DRAIN.....	14
COMPARTMENT.....	14
DOOR GASKET	14
LEAVE COMPARTMENT DOOR OPEN.....	14
STAINLESS STEEL EQUIPMENT CARE AND CLEANING.....	15
MAINTENANCE	17
REMOVAL OF LIME SCALE DEPOSITS	17
DOOR GASKET	17
COOKING HINTS.....	18
ACCEPTABLE PAN SIZES.....	18

HC24EO SERIES STEAMER

COOKING GUIDELINES 18
 Preparation 18
 Frozen Food Items..... 18
PRODUCTS TO BE COOKED IN SOLID PANS 19
PRODUCTS TO BE COOKED IN PERFORATED PANS..... 20
TROUBLESHOOTING 22
SERVICE AND PARTS INFORMATION..... 23

INSTALLATION, OPERATION AND CARE OF MODEL HC24EO SERIES STEAMERS

PLEASE KEEP THIS MANUAL FOR FUTURE USE

GENERAL

Vulcan convection steamers are produced with quality workmanship and material. Proper installation, usage and maintenance will result in many years of satisfactory performance. It is suggested that you thoroughly read this entire manual and carefully follow all of the instructions provided.

The HC24EO3 Steamer is rated at 8.0 kW and the HC24EO5 Steamer is rated at 12.0 kW.

Model HC24EO3 can accommodate three 2¹/₂" deep (6.4 cm) steam pans. Model HC24EO5 can accommodate five 2¹/₂" deep (6.4 cm) steam pans. The HC24EO3 and HC24EO5 electric convection steamers are designed for cooking vegetables, eggs, and other foods, in commercial kitchens. The steamer has a 0 to 60 minute timer. The steamers are designed for installation on countertops or on optional stands.

INSTALLATION

Before installing, verify that the electrical supply agrees with the specifications on the data plate located on the front of the steamer in the lower right hand corner. If the supply and equipment requirements do not agree, do not proceed with the installation. Contact your dealer or Vulcan-Hart immediately.

The HC24EO3 is shipped pre-wired for 208 V, 50 to 60 Hz, 3-phase. 240 V and single phase operation require changes to the heater connection 240 V, 50 to 60 Hz, 3-phase / 240 V, 50 to 60 Hz, 1-phase and 208 V, 50 to 60 Hz, 1-phase.

The HC24EO5 is voltage specific. It is available at 208 V, 50 to 60 Hz, 3-phase / 240 V, 50 to 60 Hz, 3-phase or 480 V, 50 to 60 Hz, 3-phase. It can be field converted to single phase.

UNPACKING

This steamer was inspected before leaving the factory. The transportation company assumes full responsibility for safe delivery upon acceptance of the shipment. Immediately after unpacking, check for possible shipping damage. If the steamer is found to be damaged, save the packaging material and contact the carrier within 15 days of delivery.

INSTALLATION CODES AND STANDARDS

The steamer must be installed in accordance with:

In the United States of America:

1. State and local codes.
2. National Electrical Code, ANSI/NFPA-70 (latest edition). Copies may be obtained from The National Fire Protection Association, Batterymarch Park, Quincy, MA 02269.
3. *Vapor Removal from Cooking Equipment*, (NFPA-96, latest edition) available from NFPA.

In Canada:

1. Local codes.
2. Canadian Electric Code, CSA C22.2 (latest edition). Copies may be obtained from The Canadian Standard Association, 5060 Spectrum Way, Suite 100, Mississauga, Ontario, Canada L4W 5N6.

LOCATION

The installation location must allow adequate clearances for servicing and proper operation. Minimum clearance for proper air circulation is 2" (5.1 cm) on the sides and 6" (15.2 cm) on the back.

LEVELING FEET

This steamer is shipped with four 2" leveling feet. Optional 4" leveling feet are available. The 2" feet can be removed and the optional 4" feet can be threaded into holes on the bottom of the unit.

LEVELING

Position and level the unit using leveling feet. Front of unit should be $\frac{1}{16}$ " to $\frac{1}{8}$ " higher than the rear as indicated in Figure 1. Unit should be level side to side.

Level the steamer front to back and side to side by turning the adjustable feet.

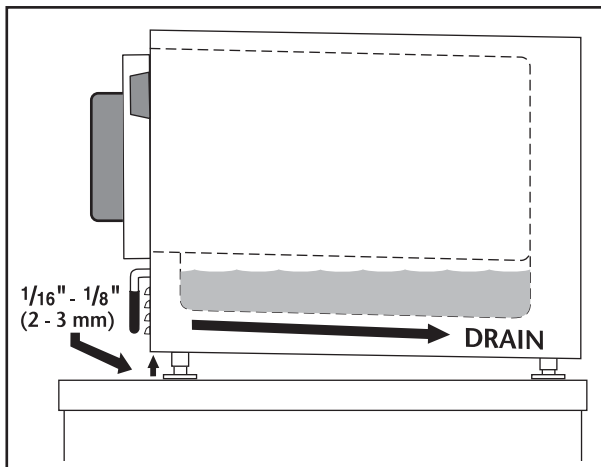

Figure 1: Leveling Steamer

ANCHORING STEAMER

1. Place steamer in the desired location on the countertop and mark four corners. Remove the steamer and drill $\frac{1}{2}$ " holes as indicated in Figure 2.
2. Apply a bead of RTV or other NSF approved sealant around the bottom edge of the steamer. If anchoring the steamer, this bottom seal is necessary to meet NSF requirements.
3. Set steamer on countertop and bolt down securely with $\frac{3}{8}$ " by 16" bolts (not supplied). Screw length should be tabletop thickness plus $\frac{1}{2}$ " for proper thread engagement.

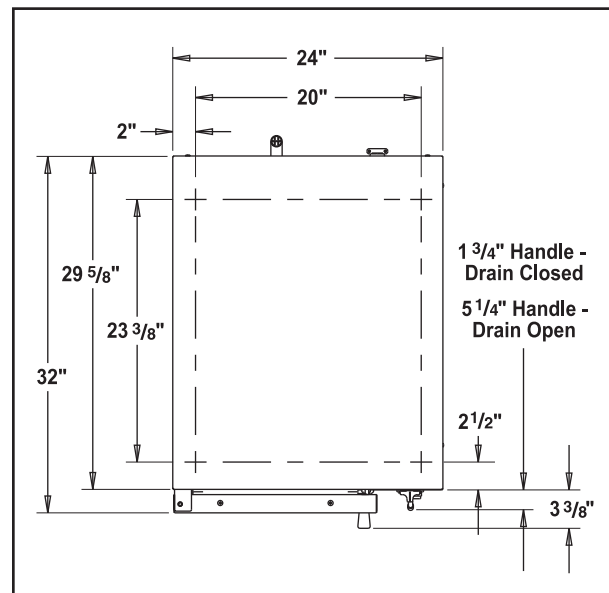

Figure 2: Anchoring Steamer

OPTIONAL ACCESSORIES

Optional accessories such as stands and stacking kit will include directions for assembly.

ELECTRICAL CONNECTIONS

⚠ WARNING: Electrical and grounding connections must comply with the applicable portions of the National Electrical Code and/or other local electrical codes.

When making electrical connections, use copper wire suitable for at least 200°F (90°C). The steamer must be grounded. The wiring diagram is located on the inside of the right panel.

Steamers are wired for 3-phase and can be converted to 1-phase by relocating the jumper wires on the terminal block as shown on the wiring diagram.

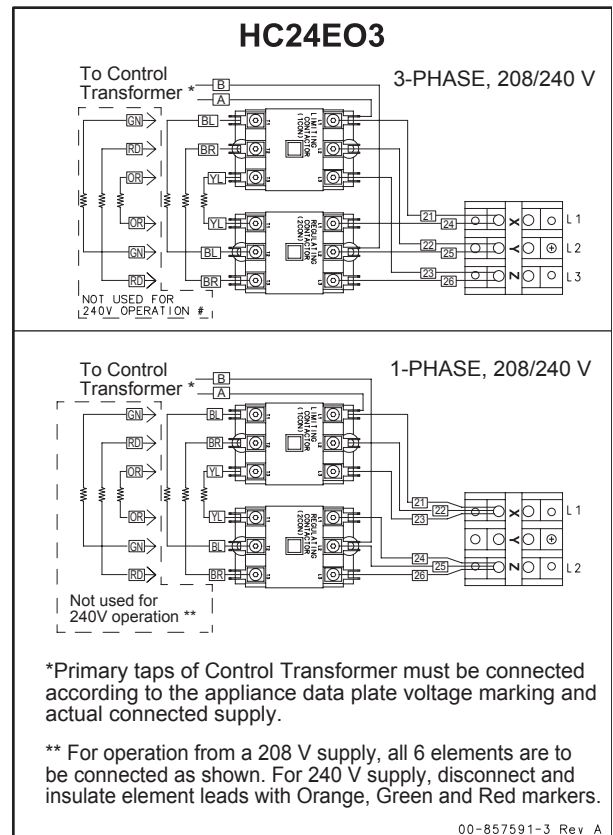
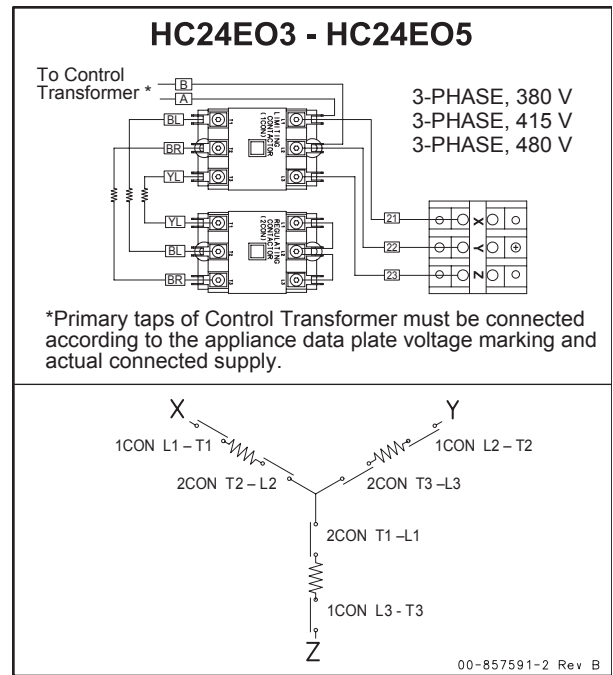
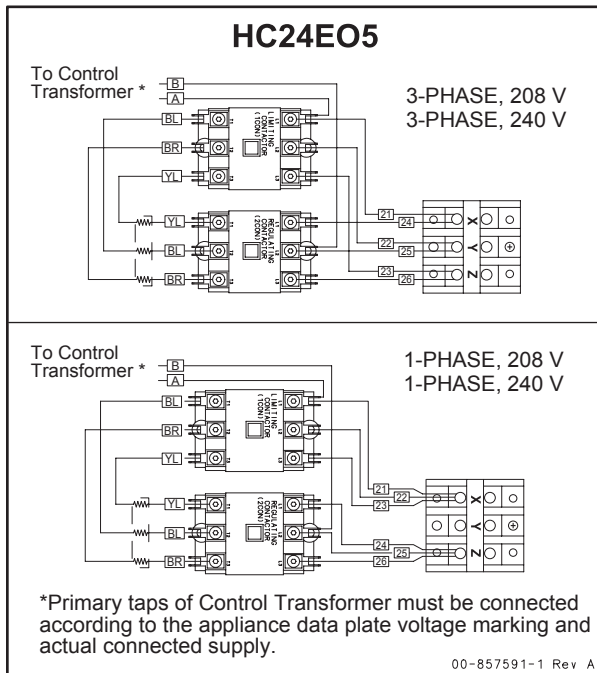

ELECTRICAL DATA

Model	Volts	KW	Amp @ 1 PH	Amp @ 3 PH
HC24EO3	208	8	38.5	22.2
	240	8	33.3	19.2
HC24EO5	208	12	57.7	33.3
	240	12	50.0	28.9
	480	12	N/A	14.4

SERVICE CONNECTIONS

Water Connections

No water supply connections are required, as the steamer is filled manually.

Water Treatment

A local water treatment specialist should be consulted before installation of steam generating equipment.

Hardness*	No more than 3 grains
Silica	less than 13 ppm
Total Chlorine	less than 4.0 ppm
PH	range 6.5 to 8
Undissolved Solids	less than 5 microns
*17.1 ppm = 1 grain of hardness	

If the water supply fails to meet these standards, it will be necessary to install a water conditioner. The use of strainers or filters will not remove minerals from the water.

Water Requirements

Proper water quality can improve the taste of the food prepared in the steamer, reduce liming in the steam generator and extend equipment

life. Water conditions vary from one location to another. Ask your municipal water supplier for details about your local water supply prior to installation. Presence of sediment, silica, excess chlorides or other dissolved solids may lead to a recommendation for alternate form(s) of water treatment. Test the water with the test strip included with the steamer. Other factors affecting steam generation are iron content, amount of chloridation and dissolved gases.

Drain Connection

The C24EO can be configured to drain through either the rear panel or through the bottom base plate.

The unit is configured to be drained through the rear panel from the factory. The unit is supplied with a 12" length of 5/8" ID hose. If this length is insufficient, remove the hose and install a new hose ordered to the desired length. The factory 5/8" ID silicone hose part number is 557475. Hose is sold by the foot.

See Figure 3.

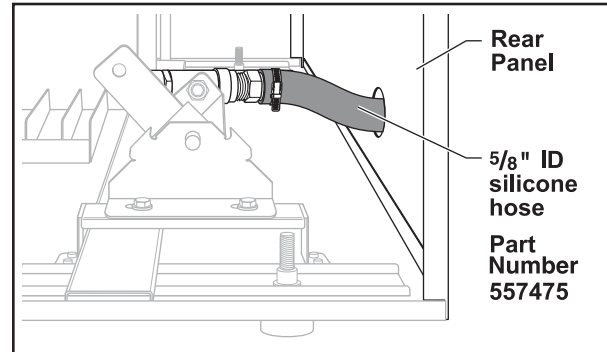

Figure 3: Rear Panel Drain Connection (Viewed with right side panel removed)

To field configure the drain through the bottom base plate, the 4" leg kit (part number 843889) is required. Also required are a 1/2" NPT close pipe nipple (1 1/8" long) and a 1/2" NPT 90° elbow, which are available through local home improvement or plumbing supply houses.

1. Remove right side panel.
2. Remove hose barb from drain.
3. Remove knockout from base plate.

4. Install the 1/2" NPT close nipple (1 1/8" long) into drain.
5. Install 1/2" NPT 90° elbow onto pipe nipple.
6. Re-use hose barb.
7. Install hose barb into elbow with clamp, cut to desired length or route to drain.

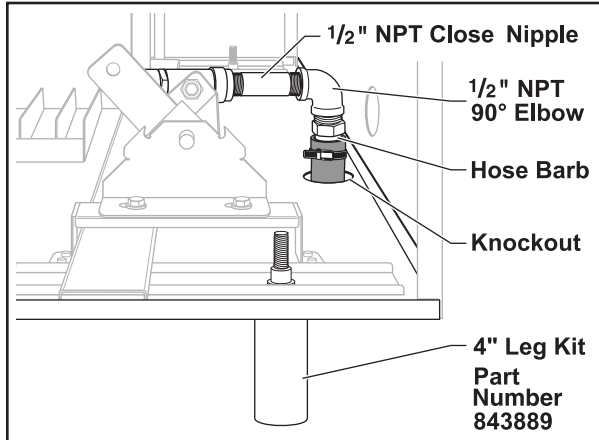

Figure 4: Bottom Panel Drain Connection (Viewed with right side panel removed)

NOTICE Do not connect steamer drain solidly to any drain piping. The steamer drain must vent to the atmosphere to avoid creating a back pressure and possible back siphoning into the compartment.

VENT HOOD

Local codes may require the steamer to be located under an exhaust hood. Information on the construction and installation of ventilating hoods may be obtained from *Vapor Removal from Cooking Equipment*, NFPA Standard No. 96 (latest edition).

BEFORE FIRST USE

Thoroughly clean the steamer before using for the first time. See the CLEANING section in this manual.

INSTALLATION STARTUP PROCEDURE

WARNING: The steamer and its parts are hot. Use care when operating, cleaning or servicing the steamer. The cooking compartment contains live steam and hot water. Stay clear when opening the door.

Once the steamer is installed, thoroughly test the steamer before operation.

1. Check that the proper electrical connections have been made.
2. Close the drain valve by pushing the Drain Handle in, located in the lower right hand corner. Open the door and pour water into the cooking compartment up to the water level mark (the water level mark is visible on the back wall of the steamer). **Do not overfill.**

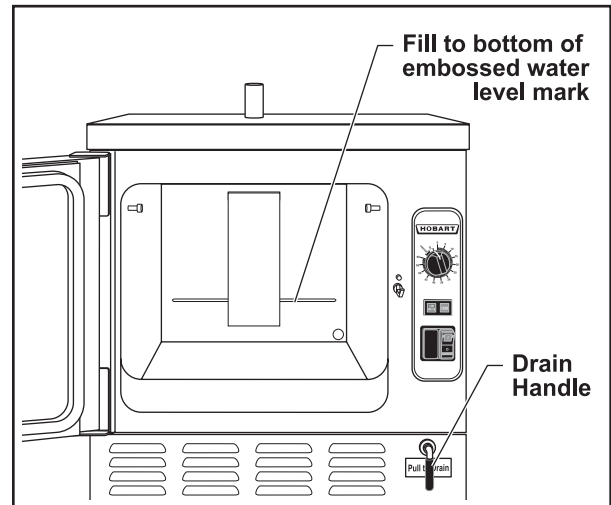



Figure 5: Water Level Mark

3. Rotate the Timer to CONTINUOUS position. Fully depress the Power Switch to the ON  position. The Power Switch will turn amber, indicating the unit is turned on.
4. With the door open, press in on the door switch (small rod), located above the door latch. The COOK light will come on. Release the door switch and the COOK light will turn off.

HC24EO SERIES STEAMER

5. Close the compartment door and wait approximately 10 minutes for unit to preheat.
6. Rotate the Timer to 5 minutes. The Timer will not start counting down until the cavity has reached preheat temperature.
7. When the timer returns to 0, a buzzer will sound signaling the end of the cooking cycle. To silence the buzzer, turn the Timer dial to the OFF position.
8. To turn the steamer off:
 - a. Depress the Power Switch to the OFF  position.
 - b. Allow the steamer to cool.
 - c. Open the drain valve and drain the water from the steamer.
 - d. Open the compartment door to allow the inside to dry out.

CALIBRATION PROCEDURE

The right hand side panel must be removed to access the temperature controller. To achieve optimum steamer operation, rotate the Temperature Control to the temperature that corresponds to the elevation that it is located at.

NOTE: The steamer is preset at the factory to sea level.

A handheld digital thermometer and thermocouple are required.

NOTE: If temperature setting is too high, the boiling action will be excessive and cause water droplets to exit the steam vent pipe resulting in high water usage.

ELEVATION (FT)	DIGITAL THERMOMETER - °F (C)
Sea Level	210 (99)
1,000	208 (98)
2,000	206 (97)
3,000	204 (96)
4,000	202 (94)
6,000	198 (93)
7,000	196 (91)
8,000	195 (90)
9,000 or above	194 (90)

1. Remove right side panel.
2. Place a temperature probe approximately one inch down in the center of steam vent pipe.
3. Turn steamer on by selecting CONTINUOUS mode.
4. Using the table above, find the corresponding temperature for the elevation and set the Temperature Control.

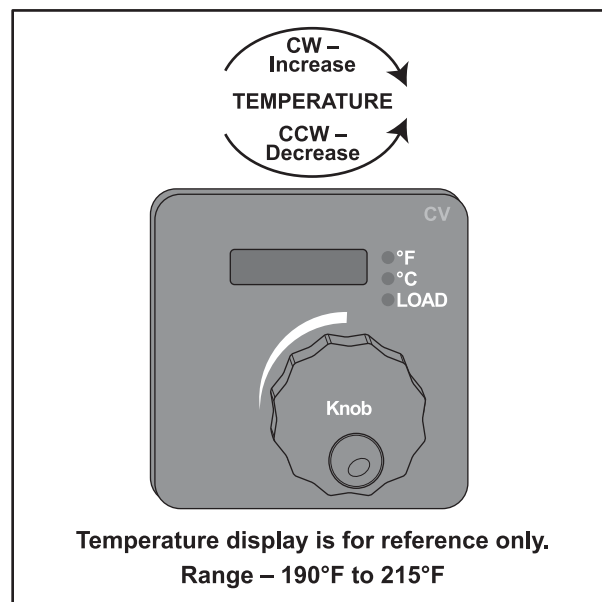

Figure 6: Temperature Control

NOTE: Temperature Control is configured by vendor to Fahrenheit and cannot be changed to Celsius. The display indicates set point temperature only.

- a. Wait 3 seconds after releasing the knob for the selection to be saved in memory. Display will blink momentarily to indicate temperature is saved.
- b. Allow temperature to stabilize by completing two heating cycles with door closed.

NOTE: Temperature display on control is for reference only. When calibrating, use the recorded temperature from meter.

5. Record temperature reading from meter when load light goes out.
6. Compare recorded temperature to the temperature from table.
 - a. If recorded temperature is correct, no adjustment is necessary.
 - b. If recorded temperature is not correct, adjust temperature setting and re-check the temperature reading with meter.

NOTE: If unit cannot be calibrated call your Authorized Vulcan Servicer.

7. If correct temperature reading is not attained after 3 attempts, call your Authorized Vulcan Servicer.

OPERATION

CONTROLS

⚠ WARNING: The steamer and its parts are hot. Use care when operating, cleaning or servicing the steamer. The cooking compartment contains live steam and hot water. Stay clear when opening the door.

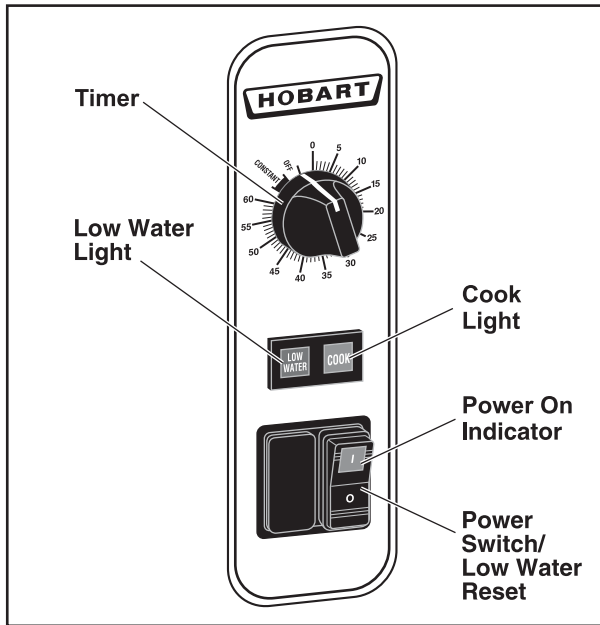

Figure 7: Controls

Power Switch/Low Water Reset: Turns unit OFF/ON/RESETS LOW WATER LIGHT/ALARM.

Low Water Light: When lit, indicates additional water is required.

Timer: Selects the desired cooking time or the CONTINUOUS position.



COOK Light: When lit, indicates the timer is set and door is closed.

OPERATING THE STEAMER

1. Push the the drain lever in to close the drain valve.
2. Open the door and pour water into the cooking compartment up to the water level mark. The water level mark is visible on the back wall of the steamer. Unit capacity is 3 gallons. **Do not overfill.**
3. Close door.
4. Verify Timer is in the OFF position.
5. Fully depress Power Switch to ON  position. Power light in switch will illuminate amber.
6. Set timer to 5 minutes. In approximately 15 minutes unit will be preheated and ready to cook.
7. Set timer to desired time (0 to 60 minutes) or to CONTINUOUS position.
8. At the end of the timed cycle an audible alarm will sound.
9. The unit returns to the idle temperature.

NOTE: Timer will not function until preheat has been completed.

LOW WATER

1. When the Low Water light is illuminated the unit needs to be refilled with water. An audible alarm will sound.
2. Fully depress Power Switch to OFF  position.
4. Refill unit with water.
5. Close door.
6. Fully depress Power Switch to ON  position to cancel Low Water alarm.
7. Timer will resume when steamer reaches cooking temperature.

NOTE: Refill the unit when not in use or during slow times to avoid running out of water. Running out of water during a cooking cycle will lengthen cook time.

SHUTDOWN

1. Rotate Timer to OFF position.
2. Fully depress Power Switch to OFF  position.
3. Allow steamer to cool.
4. Open the drain valve and drain the water from steamer.
5. Open the compartment door to allow the inside to dry.
6. Follow cleaning instructions in this manual.

EXTENDED SHUTDOWN

1. Fully depress Power Switch to OFF  position.
2. Clean the interior and exterior of unit.
3. Leave door open.
4. Disconnect power.

CLEANING

COOKING COMPARTMENT DRAIN

Remove any particles or debris that may be blocking the drain. Make a solution of warm water with non-chloride detergent and pour 1/2 gallon (1.9 liters) of it down the compartment drain. Rinse by pouring 1/2 gallon (1.9 liters) of hot water down the compartment drain.

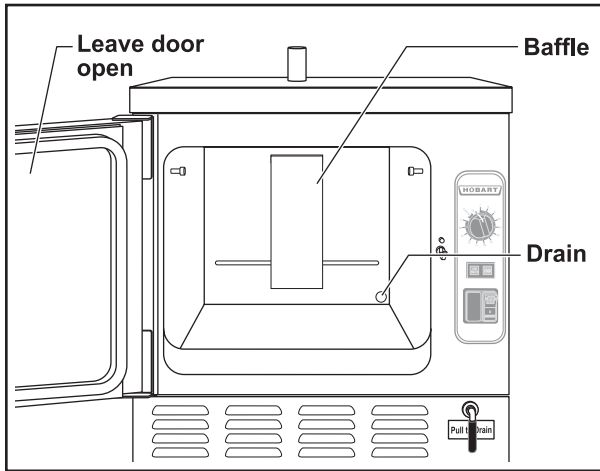

Figure 8: Oven Cavity

COMPARTMENT

The compartment, pan guides, and baffle should be cleaned daily. The exterior should be cleaned daily.

Remove the pan guides by lifting up and out. Wash with a solution of warm water with non-chloride detergent. Rinse with warm water.

Remove the baffle from the compartment by lifting up and out. Wash with a solution of warm water with non-chloride detergent. Rinse with warm water.

NOTE: Failure to reinstall baffle after cleaning will affect cooking performance.

Wash the inside of the compartment with a solution of warm water with non-chloride detergent. Rinse with warm water.

Thoroughly clean the exposed surfaces (sides, front, door and top) with a damp cloth and polish with a clean cloth daily. To remove discolorations, use a nonabrasive cleaner.

DOOR GASKET

Clean the gasket sealing surface of the compartment door daily to remove food acids for maximum gasket life. Do not use any solvents or sharp instruments. Wash with a cloth moistened in a solution of mild detergent and warm water. Rinse with a fresh cloth moistened with warm water to remove all traces of detergent.

Wipe dry with a clean cloth. Never apply food oils or petroleum lubricants directly to the door gasket. Petroleum-based solvents and lubricants will reduce gasket life.

LEAVE COMPARTMENT DOOR OPEN

Leave the compartment door slightly open when the steamer is not in use. When the compartment is idle, never latch the door and apply pressure to the door gasket. Leaving the gasket under pressure can cause permanent deformation and reduce gasket life.

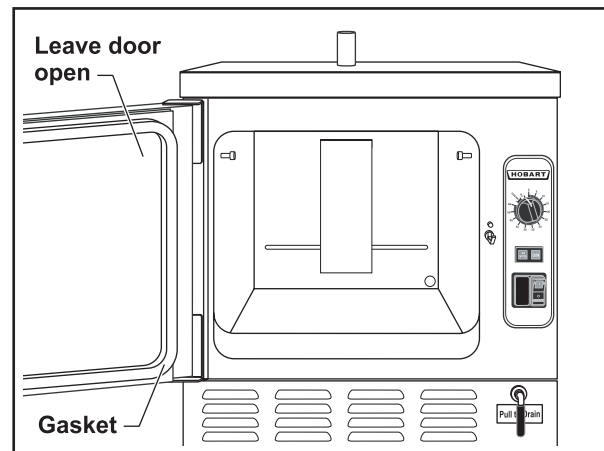

Figure 9: Leave Door Open

STAINLESS STEEL EQUIPMENT CARE AND CLEANING

Contrary to popular belief, stainless steels ARE susceptible to rusting.

Corrosion on metals is everywhere. It is recognized quickly on iron and steel as unsightly yellow/orange rust. Such metals are called “active” because they actively corrode in a natural environment when their atoms combine with oxygen to form rust.

Stainless steels are passive metals because they contain other metals, like chromium, nickel and manganese, that stabilize the atoms. 400 series stainless steels are called ferritic, contain chromium, and are magnetic; 300 series stainless steels are called austenitic, containing chromium and nickel; and 200 series stainless, also austenitic, contains manganese, nitrogen and carbon. Austenitic types of stainless are not magnetic, and generally provide greater resistance to corrosion than ferritic types.

With 12 to 30% chromium, an invisible passive film covers the steel’s surface acting as a shield against corrosion. As long as the film is intact and not broken or contaminated, the metal is passive and stainless. If the passive film of stainless steel has been broken, equipment starts to corrode and starts to rust.

Enemies of Stainless Steel

There are three basic things which can break down stainless steel’s passivity layer and allow corrosion to occur.

1. Mechanical abrasion.
2. Deposits and water.
3. Chlorides.

Mechanical abrasion means those things that will scratch a steel surface. Steel pads, wire brushes and scrapers are prime examples.

Water comes out of the faucet in varying degrees of hardness. Depending on what part of the country you live in, you may have hard or soft water. Hard water may leave spots, and when heated leaves deposits behind that if left to sit, will break down the passive layer and rust stainless steel. Other deposits from food preparation and service must be properly removed.

Chlorides are found nearly everywhere. They are in water, food and table salt. One of the worst chloride perpetrators can come from household and industrial cleaners.

So what does all this mean? Don’t despair!

Here are a few steps that can help prevent stainless steel rust.

1. Use the proper tools.

When cleaning stainless steel products, use non-abrasive tools. Soft cloths and plastic scouring pads will not harm steel’s passive layer. Stainless steel pads also can be used but the scrubbing motion *must* be in the direction of the manufacturers’ polishing marks.

2. Clean with the polish lines.

Some stainless steel comes with visible polishing lines or grain. When visible lines are present, always scrub in a motion parallel to the lines. When the grain cannot be seen, play it safe and use a soft cloth or plastic scouring pad.

3. Use alkaline, alkaline chlorinated or non-chloride containing cleaners.

While many traditional cleaners are loaded with chlorides, the industry is providing an ever-increasing choice of non-chloride cleaners. If you are not sure of chloride content in the cleaner used, contact your cleaning supplier. If your present cleaner contains chlorides, ask your supplier if they have an alternative. Avoid cleaners containing quaternary salts; it also can attack stainless steel and cause pitting and rusting.

4. Treat your water.

Though this is not always practical, softening hard water can do much to reduce deposits. There are certain filters that can be installed to remove distasteful and corrosive elements. To insure proper water treatment, call a treatment specialist.

5. Keep your food equipment clean.

Use alkaline, alkaline chlorinated or non-chloride cleaners at recommended strength. Clean frequently to avoid build-up of hard stubborn stains. If you boil water in stainless steel equipment, remember the single most likely cause of damage is chlorides in the water. Heating cleaners that contain chlorides have a similar effect.

6. Rinse, rinse, rinse.

If chlorinated cleaners are used, rinse and wipe equipment and supplies dry immediately. The sooner you wipe off standing water, especially when it contains cleaning agents, the better. After wiping equipment down, allow it to air dry; oxygen helps maintain the stainless steel's passivity film.

7. Never use hydrochloric acid (muriatic acid) on stainless steel.

8. Regularly restore/passivate stainless steel.

Recommended cleaners for specific situations

Job	Cleaning Agent	Comments
Routine cleaning	Soap, ammonia, detergent, Medallion	Apply with cloth or sponge
Fingerprints & smears	Arcal 20, Lac-O-Nu Ecoshine	Provides barrier film
Stubborn stains & discoloration	Cameo, Talc, Zud, First Impression	Rub in direction of polish lines
Grease & fatty acids, blood, burnt-on-foods	Easy-off, De-Grease It Oven Aid	Excellent removal on all finishes
Grease & oil	Any good commercial detergent	Apply with sponge or cloth
Restoration/Passivation	Benefit, Super Sheen	

Review

1. Stainless steels rust when passivity (film-shield) breaks down as a result of scrapes, scratches, deposits and chlorides.
2. Stainless steel rust starts with pits and cracks.
3. Use the proper tools. Do not use steel pads, wire brushes or scrapers to clean stainless steel.
4. Use non-chlorinated cleaners at recommended concentrations. Use only chloride-free cleaners.
5. Soften your water. Use filters and softeners whenever possible.
6. Wipe off cleaning agent(s) and standing water as soon as possible. Prolonged contact causes eventual problems.

To learn more about chloride-stress corrosion and how to prevent it, contact the equipment manufacturer or cleaning material supplier.

Developed by Packer Engineering, Naperville, Ill., an independent testing laboratory.

MAINTENANCE

⚠ WARNING: The steamer and its parts are hot. Use care when operating, cleaning or servicing the steamer. The cooking compartment contains live steam and hot water. Stay clear when opening the door.

Steamer must be cleaned daily. See CLEANING section.

REMOVAL OF LIME SCALE DEPOSITS

⚠ WARNING: Read and follow the instructions on the deliming material package. Avoid contact with skin and eyes. Wear plastic or rubber gloves and safety goggles when handling. Wash thoroughly after handling. If deliming solution comes in contact with the skin or eyes, rinse thoroughly with clean water.

⚠ WARNING: The steamer and its parts are hot. Use care when operating, cleaning or servicing the steamer. The cooking compartment contains live steam and hot water. Stay clear when opening the door.

The steamer should be delimed when scale is present in the cavity well. Deliming may be required frequently depending on water quality and scale build up. This is in accordance with the minimum preventive maintenance schedule required by warranty.



Items required (not provided):

1. Deliming Solution – Scale Release™
Part Number 854893-13 (qty. 1).
 - Contact the local Authorized Vulcan Servicer or refer to website www.hobartcorp.com

2. Plastic or rubber gloves.
3. Safety goggles or face shield.
4. Spray bottle.
5. 1-gallon container for mixing the deliming solution.

NOTE: Deliming solution may cause the surface of aluminum measuring tools to tarnish or etch.

Procedure:

1. Turn steamer off. Drain the steamer.
2. One bag will treat a C24EO3 or C24EO5 steamer.
 - 1 bag to 2 gallons warm water
3. Spray cavity walls with solution. Pour solution into cavity well.
 - Maximum steamer capacity 3 gallons
4. Fully depress Power Switch to ON  position and set Timer for 5 min. After timer sounds, rotate Timer dial to OFF position and fully depress Power Switch to OFF  position.
5. Let delime solution soak for a minimum of 30 minutes, maximum 60 minutes. If scale is still present, repeat steps 1 through 5.
6. Drain the steamer and rinse thoroughly with warm clean water.
7. Dry with a clean dry cloth.
8. Leave steamer door open when not in use.

DOOR GASKET

If the door gasket is leaking due to a nick or cut, it must be replaced. Damage to the gasket sealing surface will cause steam leakage.

COOKING HINTS

The steamer efficiently cooks vegetables and other foods for immediate serving. Steam cooking should be carefully time controlled. Keep hot food holding-time to a minimum to produce the most appetizing results. Prepare small batches. Cook only enough to start serving, then cook additional amounts to meet demand.

ACCEPTABLE PAN SIZES

The steamer accommodates combinations of full, half and one-third size pans, solid or perforated.

Model	Number of Pans Accommodated			
	Depth of Pan			
	1"	2 1/2"	4"	6"
C24EO3	6	3	2	1
C24EO5	10	5	3	2

COOKING GUIDELINES

The steamer cooks vegetables, frankfurters, eggs in their shells, and certain other meats or food items at atmospheric pressure.

These cooking guidelines are suggestions only. You should experiment with your food products to determine the cooking times that will give you the best results. Variables which affect cooking time include size, weight, thickness of foods, temperature, density, previous condition of the foods (fresh, pre-blanching or frozen) and degree of doneness desired.

PREPARATION

Prepare vegetables, fruits, meats, seafood and poultry normally by cleaning, separating, cutting, removing stems, etc. Cook root vegetables in a perforated pan. Other vegetables may be cooked in a perforated pan unless juices are being saved. Liquids can be collected in a solid 12" x 20" pan placed under a perforated pan.

Perforated pans are used for frankfurters, wieners and similar items when juices do not need to be preserved. Solid pans are good for cooking puddings, rice, and hot breakfast cereals. Vegetables and fruits are cooked in solid pans in their own juice. Meats and poultry are cooked in solid pans to preserve their juice or retain broth.

Canned foods can be heated in their opened cans (cans placed in 12" x 20" solid pans) or the contents may be poured into solid pans. DO NOT place unopened cans in the steamer.

Frozen Food Items

Separate frozen foods into smaller pieces to allow more efficient cooking.

Use a pan cover for precooked frozen dishes that cannot be cooked in the covered containers in which they are packed if they require more than 15 minutes of cooking time. When a cover is used, approximately one-third additional cooking time is necessary.

Cooking time for frozen foods depends on the amount of defrosting required. If time permits, allow frozen foods to partially thaw overnight in a refrigerator. This will reduce their cooking time.

PRODUCTS TO BE COOKED IN SOLID PANS

PRODUCT	TIME (MINUTES)	WEIGHT PER PAN
Eggs, Scrambled	9 to 12	8 doz.
Rice, Long Grain (Cover with 4 cups water/lb.)	23 to 25	2 lbs.
Pasta (Place perforated pan inside solid pan, cover with cold water)		
Spaghetti Regular/Vermicelli	10 to 15	
Macaroni - Shells/Elbows	13 to 18	
Noodles - 1/2" Wide	10 to 15	
Lasagna Noodles	13 to 18	
Frozen Casseroles, Lasagna	33 to 35	Full Pan
Meat Loaf, 3-5 Lb. Each	38 to 40	15 lbs.
Beef		
Ground Chuck	19 to 25	10 lbs.
Sliced as Purchased	33 to 40	10 lbs.
Shrimp, Frozen, 10 Shrimp per Lb.	4 to 5	4 lbs.
Beans		
Baked	8 to 9	10 lb. Can
Refried	8 to 9	10 lb. Can
Canned Vegetables	5 to 6	10 lb. Can
Prunes, Dried	11 to 15	

PRODUCTS TO BE COOKED IN PERFORATED PANS

PRODUCT	TIME (MINUTES)	WEIGHT PER PAN
SEAFOOD		
Clams		
Frozen	9 to 12	3 doz.
Fresh, Cherrystone	4 to 6	3 doz.
King Crab, Frozen		
Claws	3 to 4	2 ¹ / ₂ lbs.
Legs	3 to 6	4 ¹ / ₂ lbs.
Lobster Tail, Frozen	5 to 6	10 lbs.
Lobster, Live, 10" - 12"	4 to 5	4 Per Pan
Salmon Fillets, Frozen, 8 ounce each	4 to 5	7 ¹ / ₂ lbs.
Scallops, Fresh	3 to 4	3 lbs.
Scrod Fillets, Fresh	3 to 5	4 lbs.
EGGS		
Hard Cooked	14 to 15	4 doz.
Soft Cooked	8 to 10	4 doz.
Soft Yoke for Caesar Salad	5 to 8	4 doz.
MEATS		
Chicken — Breasts, Legs, Thighs	19 to 20	15 lbs.
Turkey, Frozen		
Breasts (2)	86 to 90	6 to 7 lbs. Each
Cut Lengthwise	53 to 55	20 to 25 lbs.
Corned Beef	40 to 75	6 to 8 lbs.
Hot Dogs and Wieners	2 to 3	80 to 100 Count
VEGETABLES		
Asparagus Spears		
Frozen	10 to 12	3 lbs.
Fresh	4 to 5	5 lbs.
Beans		
Green 2" Cut, Frozen/Fresh	5 to 6	5 lbs.
Lima, Frozen	7 to 8	5 lbs.
Baby Lima, Frozen	4 to 5	5 lbs.
Brussel Sprouts, Frozen	5 to 6	5 lbs.

PRODUCT	TIME (MINUTES)	WEIGHT PER PAN
VEGETABLES (Cont'd.)		
Broccoli		
Spears, Frozen	6 to 8	4 lbs.
Spears, Fresh	4 to 6	5 lbs.
Flowerettes, Frozen	4 to 6	5 lbs.
Cabbage, Fresh, 1/6 Cut	6 to 8	5 lbs.
Carrots		
Baby Whole, Frozen	6 to 8	7 lbs.
Crinkle Cut, Frozen	7 to 8	4 lbs.
Sliced, Fresh	9 to 11	9 lbs.
Cauliflower, Flowerettes		
Frozen	4 to 6	4 lbs.
Fresh	7 to 8	5 lbs.
Celery, 1" Diagonal Cut	5 to 7	5 lbs.
Corn		
Yellow Whole Kernel, Frozen	3 to 5	5 lbs.
Cobbettes, Frozen	6 to 8	27 Ears
Corn-On-Cob, Fresh	16 to 18	80 Ears
	16 to 18	54 Ears
	10 to 12	18 Ears
Peas, Green	4 to 6	5 lbs.
Potatoes, Whole Russet	50 to 55	40 lbs.
Spinach		
Chopped, Frozen	15 to 17	6 lbs.
Defrosted	4 to 5	6 lbs.
Fresh Cut	2 to 3	2 lbs.
Squash, Acorn Halves	22 to 25	10 Halves
Zucchini, Slices	6 to 8	10 lbs.
Frozen Mixed Vegetables	6 to 7	5 lbs.
FRUIT		
Fruit, Blanch for Peeling		
Grapefruit, Oranges	2 to 3	
Pineapple, Whole for Cutting	2 to 4	

TROUBLESHOOTING

SYMPTOMS	POSSIBLE CAUSES	REMEDY
Steamer not steaming	No main power source. Door is open. Power switch in OFF position. Timer is off. Needs water.	Check the power source. Close door. Set power switch to ON. Set Timer. Add water.
Steamer not steaming properly	Excessive scale buildup in the cavity well. Not connected to correct voltage.	Descale the steamer (see REMOVAL OF LIME SCALE DEPOSITS). If voltage is not correct, contact your Authorized Vulcan Servicer.
Door leaks	Damaged door gasket. Damage to gasket sealing surface. Blocked or obstructed steam vent.	Check door gasket for damage. If adjustment is needed, contact your Authorized Vulcan Servicer. Clear steam vent.
Water does not drain properly	Unit not level. Drain clogged.	See leveling instructions in the installation section of this manual. Unclog drain.
Water foaming	Cooking seafood without catch pan.	Use a catch pan. Drain and replace water.

SERVICE AND PARTS INFORMATION

To obtain service and parts information concerning this model, contact the Authorized Vulcan Servicer in your area. Refer to our website, www.hobartcorp.com for a complete listing of Authorized Service and Parts depots.

When calling for service, the following information (located on your machine data plate) must be available:

Model Number

Serial Number

Manufacture Date (MD)

Voltage

