

# INSTRUCTIONS



MODEL SR24H

## MODEL SR24 SERIES DISHWASHERS

### MODELS

SR24C ML-130021

SR24H ML-130022



701 S. RIDGE AVENUE  
TROY, OHIO 45374-0001

937 932-3000

[www.hobartcorp.com](http://www.hobartcorp.com)

FORM 35309 Rev. C (Mar. 2008)

## TABLE OF CONTENTS

General .....	3
Installation .....	3
Unpacking .....	3
Panel Assembly .....	3
Location .....	4
Details and Dimensions .....	4
Machine Installation Connections and Details .....	6
Plumbing Connections .....	7
Water Supply .....	7
Water Requirements .....	7
Drain .....	7
Electrical Connections .....	8
Electrical Connection (Model SR24H) .....	8
Electrical Connection (Model SR24C) .....	8
Chemical Sanitizer (Model SR24C Only) .....	8
Initial Filling (Model SR24H Only) .....	9
Priming the Booster .....	9
Booster Heater (Model SR24 Only) .....	9
Fill .....	9
Operation .....	10
Preparation .....	10
Controls .....	10
Dishwashing .....	10
Chemical Dispensing Pumps .....	11
DOs and DON'Ts for Your New Hobart Warewasher .....	11
Cleaning .....	12
Maintenance .....	13
Deliming .....	13
Deliming Model SR24C (Chemical Sanitizing Model) .....	13
Deliming Model SR24H (Hot Water Sanitizing Model) .....	14
Lubrication .....	14
Troubleshooting .....	15
Chemical Sensing Module — Operation and Start-Up .....	16
Chemical Sensing Module — To Recalibrate Sensors .....	16
Chemical Sensing Module — Troubleshooting .....	16

# Installation, Operation and Care of MODEL SR24 SERIES DISHWASHERS

## SAVE THESE INSTRUCTIONS

### GENERAL

The SR24 Series Dishwashers are fully automatic, front-loading machines that are equipped with a 1/2 H.P. electric motor.

Standard equipment includes two standard 20" x 20" racks, dial thermometers for both rinse and wash cycles, synchronous timer, pilot light and lower front trim panel. An over temperature light is standard on model SR24H only. Side and top panel kits are available should a free-standing model be desired.

The model SR24H features a built-in booster heater, while the SR24C is a low-temperature, chemical-sanitizing model for use with 6.0% sodium hypochlorite solution (bleach) as a sanitizing agent. If 8.4% bleach is to be used, contact Hobart service to change the sanitizer pump settings (charges will apply).

A chemical sensing module is an available option; it indicates when chemical supplies must be replenished.

Chemical dispensing pump(s), up to three, are available options at time of order.

### INSTALLATION

#### UNPACKING

Immediately after unpacking the dishwasher, check for possible shipping damage. If this machine is found to be damaged after unpacking, save the packaging material and contact the carrier within 15 days of delivery.

#### PANEL ASSEMBLY

If optional panel kits are to be installed, they must be installed before positioning the dishwasher. Refer to installation instructions (F-33163) supplied with panel kit.

## LOCATION

Prior to installation, test the electrical service to make sure that it agrees with the specifications on the machine data plate, located on the top of the door.

Place the machine in its operating location. Before any connections are made, the machine must be level. Use the tank seam at the top of the sump inside the tank as a reference. To level the machine, pour enough water in the tank to reach the seam and then thread the adjustable feet in or out until the water level is even with the seam.

The lower front panel must be removed to accommodate plumbing and electrical connections.

Remove the two screws that secure the lower front panel and the kick panel. Remove both panels.

Replace these panels after installation.

Machines without side and top panels should be anchored to the counter under which they are installed by assembling two screws (not supplied) through the holes in the top of the tank.

The machine must be cleaned after installation and before being put into service. Refer to the OPERATION section for detailed instructions.

## DETAILS AND DIMENSIONS

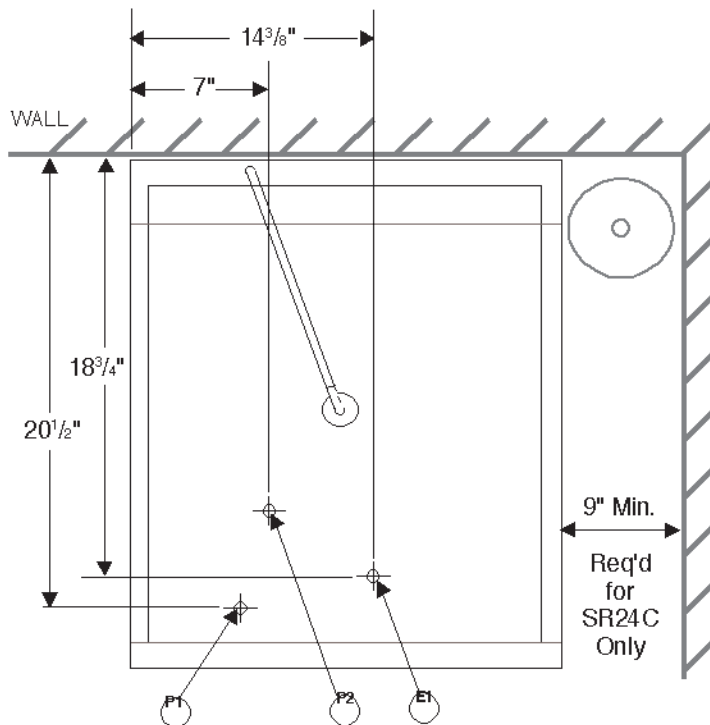

### LEGEND

- |    |  |
|----|--|
| P1 | Single fill and rinse pipe connection, $\frac{3}{4}$ " female garden hose fitting on 6' long hose supplied with the machine; 110°F water min. for SR24H; 120°F water min. for SR24C.         |
| P2 | Drain pipe connection, $\frac{3}{4}$ " MPT fitting with 10' hose supplied with the machine.  |
| E1 | Location of electrical connection, SR24H only: $\frac{3}{4}$ " elec. connector (1 $\frac{1}{8}$ " dia. hole), 4" AFF. Location of electrical connection, SR24C only: cord and plug supplied. |

### INTERIOR DIMENSIONS

- |    |   |
|----|---|
| 1. | Maximum inside height from inside rack to top wash arm is 16 $\frac{3}{8}$ ". |
| 2. | Width is 22 $\frac{9}{16}$ ".   |
| 3. | Front to rear is 21 $\frac{1}{2}$ " with door closed.                         |

NOTE: Certain materials, including silver plate, aluminum and pewter are attacked by sodium hypochlorite (bleach). Refer to DOs AND DON'Ts FOR YOUR NEW HOBART WAREWASHER.

SR24C	Net Weight of Machine:	135 lbs.
SR24C	Domestic Shipping Weight:	155 lbs.
SR24H	Net Weight of Machine:	146 lbs.
SR24H	Domestic Shipping Weight:	166 lbs.

Machine Type & Specification	Rated AMPS	Minimum Supply CKT Conductor Ampacity	Maximum Overcurrent Protective Device
SR24C 120/60/1	9	15	15
SR24H 120/240 (3W)/60/1 or 120/208(3W)/60/1	37.6 42.0	50 50	50 * 50 *

\* These are 3-wire systems that require (3) #8 AWG copper wires (90°C) including a current carrying neutral. In addition, a fourth wire must be provided for machine ground. Do not connect these machines to a 120 VAC circuit.

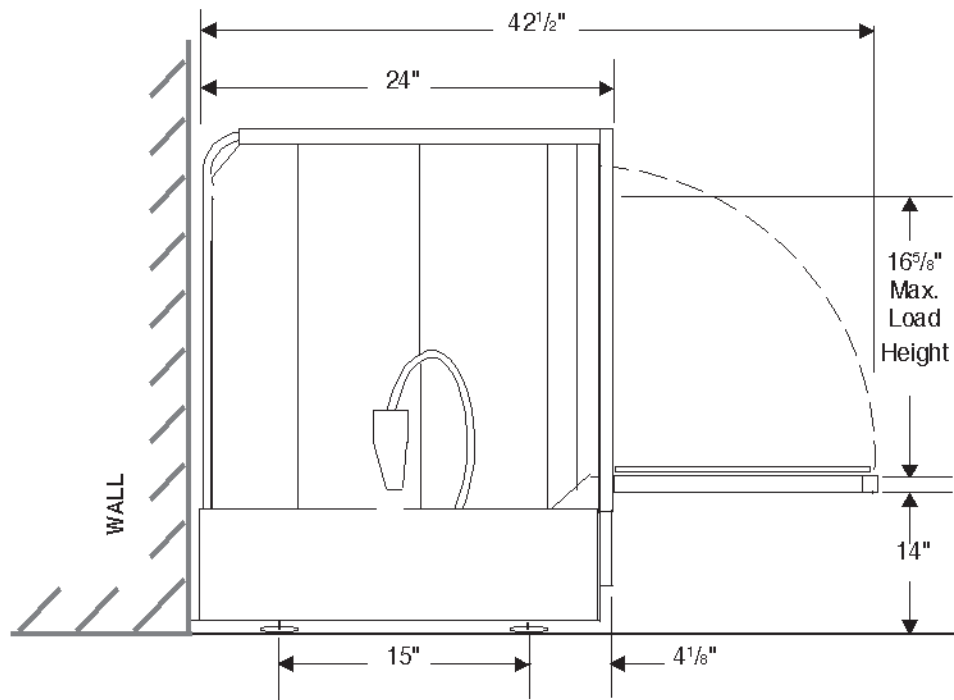
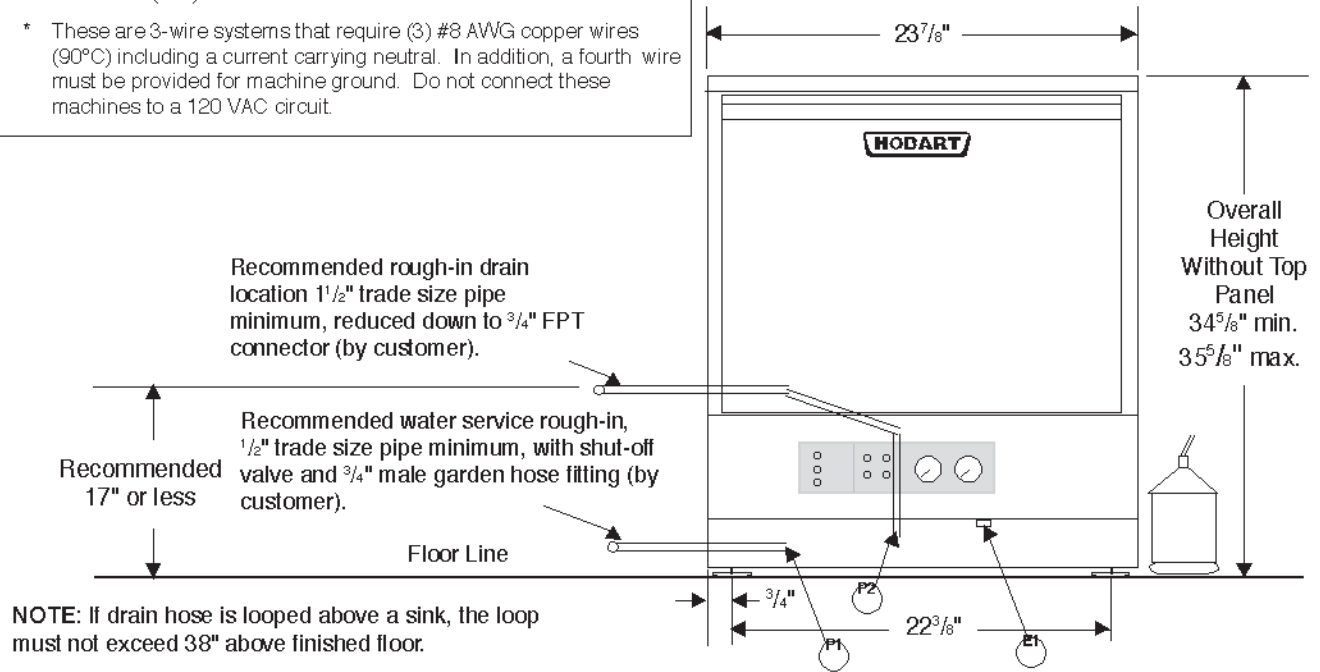

## MODELS SR24C AND SR24H WITH PANELS

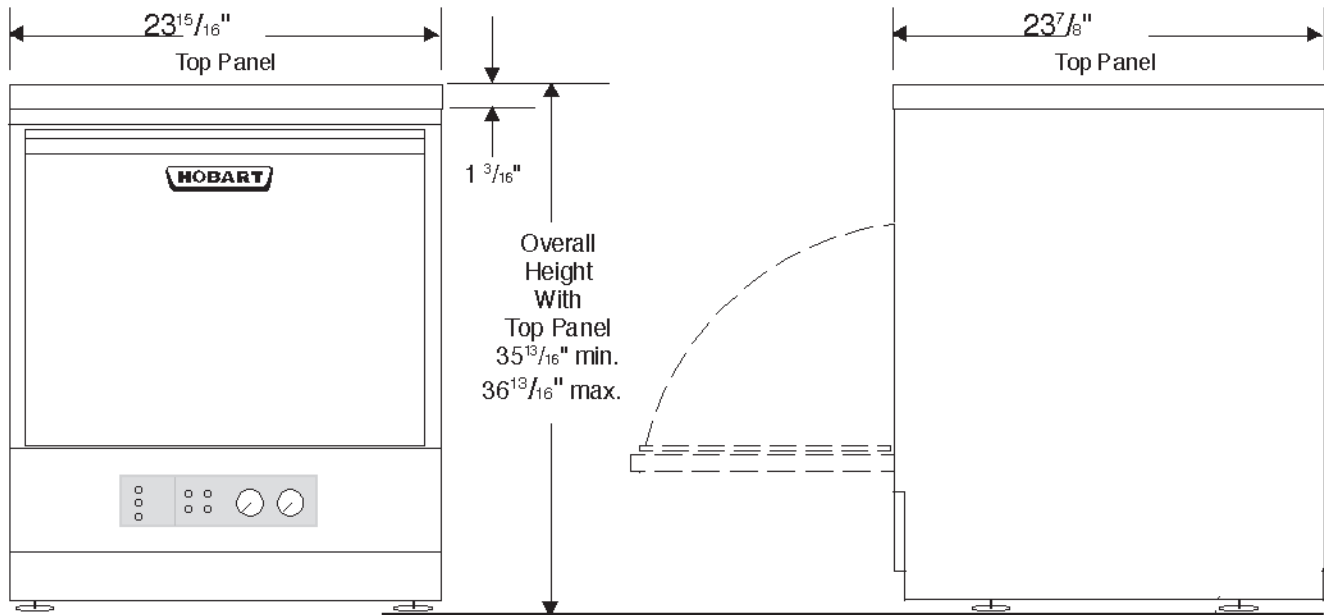

**WARNING:** NOT RECOMMENDED FOR INSTALLATION WITHIN WOODEN, PLYWOOD OR OTHER SIMILAR, NONMOISTURE-RESISTANT FRAMEWORK.

### MACHINE INSTALLATION CONNECTIONS AND DETAILS

1. Single fill and rinse pipe connection. A 6-foot flexible hose is supplied.
2. Location of electrical connection: <sup>3</sup>/<sub>4</sub>" electrical connector (1<sup>1</sup>/<sub>8</sub>" diameter hole) provided, SR24H only.
3. Cord and plug supplied on SR24C only.

**NOTE:** The sodium hypochlorite container should be placed on floor (SR24C only).

4. If a sodium hypochlorite container is to be placed in cabinet adjacent to the machine, a <sup>1</sup>/<sub>2</sub>" diameter hole is required in cabinet to run bleach supply line.
5. Pumped drain <sup>3</sup>/<sub>4</sub>" MPT fitting 10' hose supplied.
6. Line strainer is required — not supplied.

## PLUMBING CONNECTIONS

**WARNING:** PLUMBING CONNECTIONS MUST COMPLY WITH APPLICABLE SANITARY, SAFETY AND PLUMBING CODES.

### WATER SUPPLY

The water supply must be within the recommended hardness range of 4 to 6 grains per gallon. Lower hardness can cause corrosion; higher hardness can cause formation of lime scale.

The plumber who connects this machine is responsible for making certain that water lines are THOROUGHLY FLUSHED OUT BEFORE connecting to the dishwasher. This flush-out is necessary to remove all foreign matter, such as chips (resulting from cutting or threading of pipes), pipe joint compound from the lines or, if soldered fittings are used, bits of solder or cuttings from the tubing. Debris, if not removed, may lodge in the dishwasher's plumbing components and render them inoperative. Manual valves or solenoid valves fouled by foreign matter, and any expenses resulting from this fouling, are NOT the responsibility of the manufacturer.

### WATER REQUIREMENTS

Proper water quality can improve ware washing performance by reducing spotting, lowering chemical supply costs, enhancing effectiveness of labor and extending equipment life. Local water conditions vary from one location to another. The recommended proper water treatment for effective and efficient use of this equipment will also vary depending on the local water conditions. Ask your municipal water supplier for details about local water specifics before installation.

Recommended water hardness is 4 to 6 grains of hardness per gallon. Chlorides must not exceed 50 parts per million. Water hardness above 6 grains per gallon should be treated by a water conditioner (water softener or in-line treatment). Water hardness below 4 grain per gallon also requires water treatment to reduce potential corrosion. Water treatment has been shown to reduce costs associated with machine cleaning, reduce deliming of the dishwasher, reduce detergent usage and reduce corrosion of metallic surfaces in the booster water heater and dishwasher.

Sediment, silica, chlorides or other dissolved solids may lead to a recommendation for particulate filtration or reverse osmosis treatment.

If an inspection of the dishwasher or booster heater reveals lime buildup after the equipment has been in service, in-line treatment should be considered and, if recommended, should be installed and used as directed. Contact your local Hobart Service Office for specific recommendations.

**NOTE:** Iron in the water supply can cause staining. An iron filter is recommended for iron concentration greater than 0.1 parts per million. High chloride levels in the water supply can cause pitting. A chloride removal system is required if levels exceed 50 parts per million.

#### REQUIRED PLUMBING AND WATER SUPPLY CHARACTERISTICS

Model	Temperature	Flowing Pressure
SR24H	110°F Minimum	25 ± 3 psig
SR24C	120°F Minimum	25 ± 3 psig

### DRAIN

Recommended drain height is 17" AFF or less. If drain hose is looped above a sink, the loop must not exceed 38" AFF. A minimum 1½" trade size drain pipe is required, reduced down to ¾" FPT connection for flexible drain hose (supplied). Refer to DETAILS AND DIMENSIONS for more information. Check for leaks.

## ELECTRICAL CONNECTIONS

**WARNING:** ELECTRICAL AND GROUNDING CONNECTIONS MUST COMPLY WITH THE APPLICABLE PORTION OF THE NATIONAL ELECTRICAL CODE AND/OR OTHER LOCAL ELECTRICAL CODES.

**WARNING:** DISCONNECT THE ELECTRICAL POWER TO THE MACHINE AND FOLLOW LOCKOUT / TAGOUT PROCEDURES.

### BRANCH CIRCUIT SIZE AND PROTECTION (IF USING FUSED DISCONNECT USE DUAL ELEMENT TIME-DELAY FUSES)

Model	Volts	Phase	Machine Amps.	Minimum Circuit Ampacity	Maximum Protective Device	90°C Copper Wire Size
SR24C	120	1	9.0	15	15	14
SR24H	120/208 (3W)	1	37.6	50	50	*
SR24H	120/240 (3W)	1	42.0	50	50	*

\* Model SR24H uses a three-wire system that requires three #8 AWG wires (90°C), including a current-carrying neutral. In addition, a fourth wire must be provided for machine ground. Do not connect the model SR24H to a 120 VAC circuit.

**IMPORTANT:** Use copper wire only.

#### ELECTRICAL CONNECTION (MODEL SR24H)

Remove the lower front panel. Remove the terminal box cover. A hole for 3/4" conduit is supplied in the bottom of the terminal box. Make electrical connections according to the wiring diagram and the torque label supplied with the machine. Replace the terminal box cover and the lower front panel.

#### ELECTRICAL CONNECTION (MODEL SR24C)

A cord and plug is provided; a 15 amp., 120 VAC circuit is required.

#### CHEMICAL SANITIZER (MODEL SR24C ONLY)

**WARNING:** USE ONLY 6.0% SODIUM HYPOCHLORITE (BLEACH) AS SANITIZING CHEMICAL TO ENSURE PROPER OPERATION OF DISHWASHER. DO NOT PREMIX WETTING AGENT AND SODIUM HYPOCHLORITE (BLEACH) — MODEL SR24C ONLY. IF 8.4% BLEACH IS TO BE UTILIZED, CONTACT HOBART SERVICE TO CHANGE SANITIZER PUMP SETTINGS (CHARGES WILL APPLY).

Place a 1-gallon bottle of 6.0% sodium hypochlorite solution (bleach) in a desired location on the floor. Do not pre-mix the sanitizing solution with water or any other liquid.

**WARNING:** NEVER PREMIX A DELIME AGENT WITH THE SANITIZING SOLUTION. MIXING MAY CAUSE HAZARDOUS GAS TO FORM.

Remove the sanitizer bottle cap and place the standpipe assembly into the bottle. Check to make sure there are no obstructions or kinks in the delivery tube.

After electrical and plumbing connections have been made, close the door and turn the On-Off switch (Fig. 2 on page 10) to the on position. The dishwasher must be operated through nine (9) complete cycles (without dishes) to initially charge the sanitizer delivery system.

## INITIAL FILLING (MODEL SR24H ONLY)

After electrical and plumbing connections have been made make sure the water service valve is open and add a cup of water to the sump to help lubricate the seal. Close the door and turn the On-Off switch (Fig. 3 on page 10) to the on position. Cycle the machine through three wash cycles to charge the detergent delivery system and fill the booster.

## PRIMING THE BOOSTER

First time start-up:

1. Turn on the water supply and circuit breaker.
2. Turn the power switch to the on position (on lower front panel).
3. Open door and wait for cycle light to go off.
4. Close door (unit will start to fill).
5. If red over-temp light comes on, turn power switch off. Make sure water supply is turned on. Wait for 10 minutes and repeat steps 2 and 4.

If red over-temp light comes on again, repeat step 5.

## BOOSTER HEATER (MODEL SR24H ONLY)

If the over-temp light on Model SR24H (Fig. 3, page 10) becomes lit during normal operation, the booster heater protector has tripped. If this occurs turn the machine off, disconnect from the power supply and have it serviced by a qualified technician.

## FILL

For washing performance and sanitation, it is important to have sufficient water in the tank after the fill is completed. The standing water level must be above the top of the sump (Fig. 1). If this is not the case, check the flow pressure of the fill line. If flow pressure is below 22 psig, the supply line pressure must be increased. If flow pressure is above 28 psig, a pressure-reducing valve (not supplied) must be installed in the line.

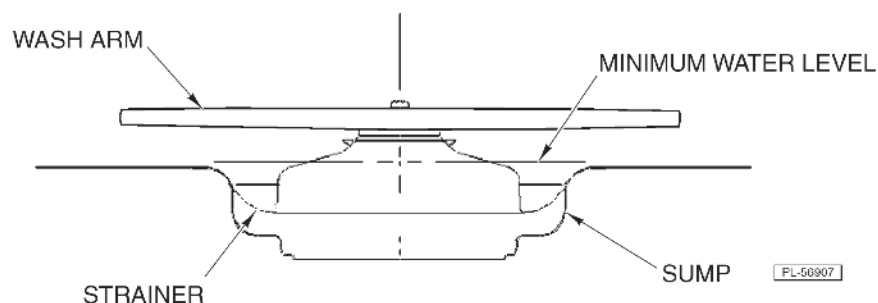

Fig. 1

# OPERATION

**Caution:** Items such as pewter, aluminum and silver are attacked by sodium hypochlorite (bleach). Therefore, the Model SR24C Chemical Sanitizing unit should not be used to wash such items.

## PREPARATION

Check to make sure that the strainer is in place and free of debris. Check both wash arms to be sure that they spin freely and are not clogged.

## CONTROLS

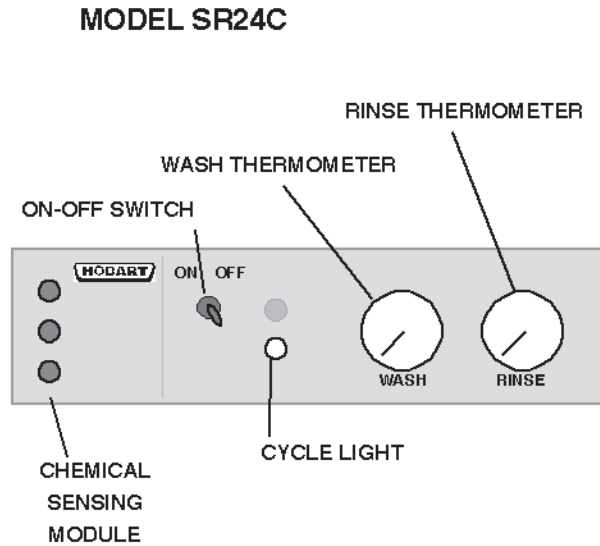

Fig. 2

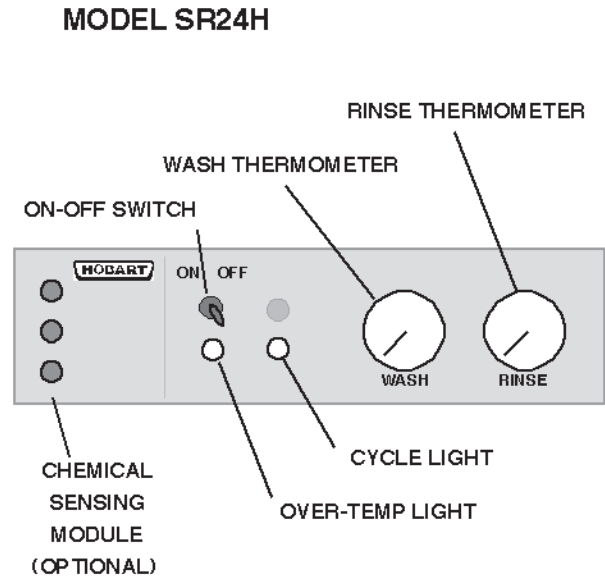

Fig. 3

## DISHWASHING

Dishes must be scraped and/or rinsed to remove food particles and other debris. Place the dishes in a rack. Do not stack dishes or racks on top of each other as water must have free access to all sides of every dish. Stand plates edgewise in a peg-type rack (Fig. 4). Cups, glasses and bowls should lay up-side down in an open or compartment-type rack (Fig. 4). Silverware and other small pieces should lay loosely on the bottom of a flat-bottomed rack.

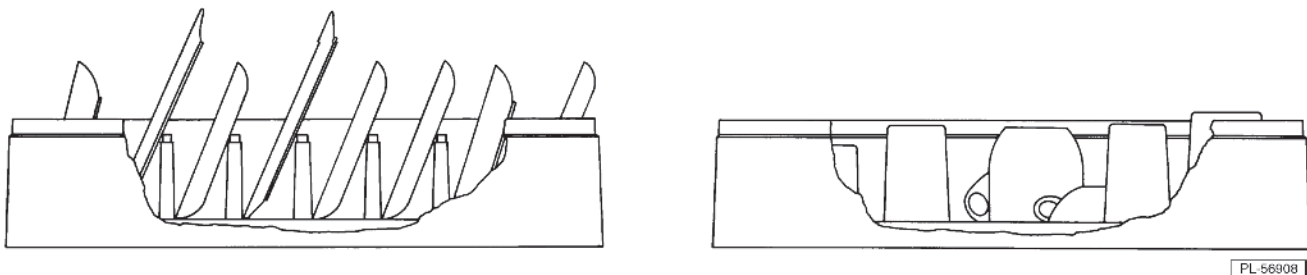

Fig. 4

Use only commercial-grade detergents recommended by your chemical professional. Do not use detergents formulated for residential dishwashers.

Chemical dispensing pumps (if so equipped) are factory set to provide proper concentration of each chemical. If adjustments are required, contact your local Hobart Service Office.

When the door is opened, the cycle light will come on during a brief reset period. When the light goes off (approximately 9 seconds), close the door, at which time the wash cycle will begin (indicated by the cycle light).

When the cycle light goes off, the cycle is completed. Open the door and remove the rack of clean dishes; after the reset period (9 seconds), the dishwasher is ready for a repeat operation.

Thermometers (Figs. 2 and 3 on page 10) are provided for convenience in checking the wash and incoming rinse water temperatures. These temperatures should be monitored occasionally during a cycle to make sure that the dishwasher is operating at or above the proper minimum temperatures.

### **CHEMICAL DISPENSING PUMPS**

The chemical sensing module will alert the operator when the supply of sanitizer has been depleted by a flashing indicator light and a periodic audible alarm. The sanitizer **MUST** be replenished immediately.

After replacing the sanitizer, the dishwasher must be operated through nine complete cycles (without dishes) to recharge the delivery system. Use the same procedure for priming of optional detergent and rinse pumps. For further details on the chemical sensing module and its start-up procedures, refer to page 16.

### **DOs AND DON'Ts FOR YOUR NEW HOBART WAREWASHER**

**DO** assure proper water hardness.

**DO** prescrape dishes thoroughly.

**DO** use only detergents recommended by your chemical professional.

**DO**, at the end of the day, thoroughly cleanse the machine, rinse and dry (leave door ajar).

**DO** closely follow your chemical professional's prescribed deliming schedule.

**DO** use only products formulated to be safe on stainless steel.

**DO NOT** oversoften water (recommended water hardness is 4 to 6 grains per gallon).

**DO NOT** use detergents formulated for residential dishwashers.

**DO NOT** allow food soil to accumulate on the tank bottom.

**DO NOT** exceed chemical manufacturer's recommended concentrations for detergent, sanitizer, rinse agent or lime scale remover.

**DO NOT** use steel wool to clean ware or warewasher surfaces.

**DO NOT** allow foreign objects to enter the unit, especially metallic contaminants.

**NOTE:** Failure to follow use, care and maintenance instructions may void your Hobart warewasher warranty.

# CLEANING

This machine must be cleaned at least once each working day.

1. Turn the On-Off switch to the off position (Figs. 2 and 3 on page 10).
2. Open the door and remove the wash arms and the strainer assembly (Fig.5).
3. To remove the lower wash arm, remove the retaining screw (Fig. 5), grasp the wash arm at the center (Fig. 6) and pull it up and out of the machine.
4. Lift strainer assembly out of sump, over wash arm shaft.
5. To remove the upper wash arm, hold the wash arm in place while removing the retaining screw (Fig. 7) and then remove the upper wash arm.
6. Thoroughly clean items in a sink.
7. With a damp cloth, wipe the interior and exterior of the machine. When cleaning the inside of the door, be sure to wipe the lip at the bottom of the door.
8. Reinstall the strainer and wash arms and tighten the retaining screw on both the upper and lower wash arms.
9. Leave the door ajar overnight to allow the interior to air out and dry.

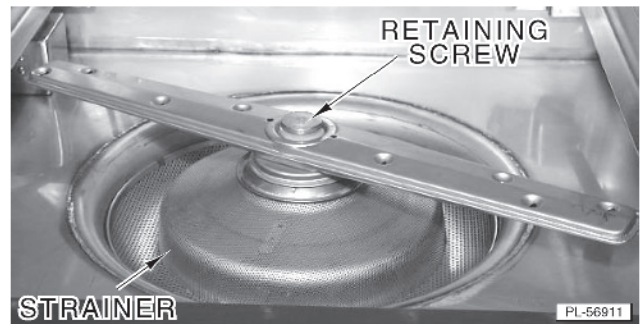

Fig. 5



Fig. 6

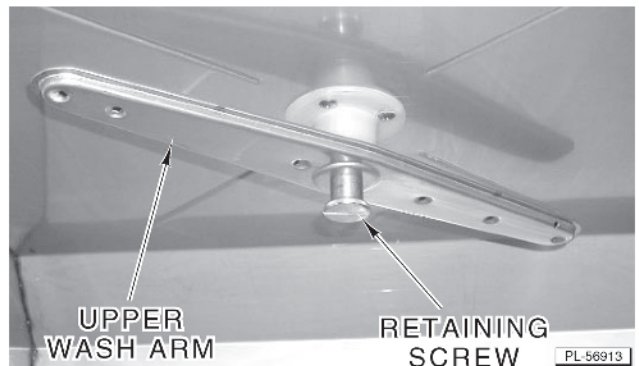

Fig. 7

# MAINTENANCE

## DELIMING

The dishwasher should be delimed on a regular basis as required. The frequency will depend on the mineral content of the supply water. Inspect the machine interior for lime deposits. If deliming is necessary, a deliming agent (such as Lime Away or LSR) should be used for best results.

Depending on the model of your machine, carefully follow the appropriate procedure outlined below.

### DELIMING MODEL SR24C (CHEMICAL SANITIZING MODEL)

**WARNING:** DELIMING SOLUTION, RINSE AGENTS OR OTHER ACIDS MUST NOT COME IN CONTACT WITH HOUSEHOLD SODIUM HYPOCHLORITE (BLEACH) OR OTHER CHEMICALS CONTAINING CHLORINE, IODINE, BROMINE OR FLOURINE, AS MIXING MAY CAUSE HAZARDOUS GAS TO FORM. CONSULT YOUR LOCAL CHEMICAL REPRESENTATIVE. THIS ENTIRE PROCEDURE MUST BE FOLLOWED STEP BY STEP FOR SAFE AND SATISFACTORY RESULTS.

Remove the standpipe assembly from the bleach container and place it in a catch pan as close to the floor as possible.

Cycle the machine nine times to clear the lines of the bleach dispensing system.

Delime as follows:

1. Remove rack from machine.
2. Close the door.
3. Allow machine to fill for 10 to 15 seconds.
4. Partially open the door and wait 5 seconds.
5. Open door; add deliming agent (carefully follow supplier's instructions).

**NOTE:** The sump holds 1.4 gallons of water.

6. Close the door and allow the machine to complete the wash/rinse cycle.
7. Inspect the interior of the machine for lime deposits. Repeat steps 2 through 6 if necessary.
8. Reconnect the bleach system and run through nine (9) complete cycles (without racks) to recharge the delivery system.

**Caution: Do not allow the deliming agent to remain in the machine longer than recommended by the deliming agent manufacturer. After deliming, the machine should be run through two cycles with no dishes to rinse and flush the machine interior BEFORE RECONNECTING BLEACH SYSTEM.**

## **DELIMING MODEL SR24H (HOT WATER SANITIZING MODEL)**

Delime as follows:

1. Remove rack from machine.
2. Close the door.
3. Allow machine to fill for 10 to 15 seconds.
4. Partially open the door and wait 5 seconds.
5. Open door; add deliming agent (carefully follow supplier's instructions).

**NOTE:** The sump holds 1.4 gallons of water.

6. Close the door and allow the machine to complete the wash/rinse cycle.
7. Inspect the interior of the machine for lime deposits. Repeat steps 2 through 6 if necessary.

**Caution: Do not allow the deliming agent to remain in the machine longer than recommended by the deliming agent manufacturer. After deliming, the machine should be run through two cycles with no dishes to rinse and flush the machine interior.**

## **LUBRICATION**

The motor has grease-packed ball bearings and, therefore, requires no lubrication.

## TROUBLESHOOTING

This section outlines various symptoms and possible causes that may be encountered if abnormal machine operation occurs. If symptoms persist after possible causes have been checked, service may be required.

<b>SYMPTOM</b>	<b>POSSIBLE CAUSE</b>
Machine does not operate.	<ol style="list-style-type: none"><li>1. On-Off switch is in the off position.</li><li>2. Blown fuse or circuit breaker off at power supply.</li><li>3. Power cord unplugged.</li></ol>
Dishes not clean.	<ol style="list-style-type: none"><li>1. Strainer clogged, causing inadequate water supply to pump.</li><li>2. Obstruction in wash arm(s). Clean according to instructions in Cleaning section of this manual.</li><li>3. Water temperature too low.</li><li>4. Incoming water supply turned off.</li></ol>
Spotting of silverware, glasses or dishes.	<ol style="list-style-type: none"><li>1. Improperly loaded racks.</li><li>2. Water temperature too low.</li><li>3. Improper type or concentration of detergent. Contact your local detergent representative.</li><li>4. Poor water quality.</li></ol>

## CHEMICAL SENSING MODULE — OPERATION AND START-UP

Operate the chemical dispensing pumps (refer to page 11) to make sure that liquid chemical is present in the tubing going through the sensors in the chemical sensing module. Once the dishwasher is switched on, LED indicator lights are lit continuously to indicate that liquid chemical is present in the tube(s).

A flashing indicator light and a periodic, audible alarm indicate that liquid chemical has been depleted and needs to be replenished.

If one or more chemicals are not going to be used, the system can be set so that the related sensor is disabled. To disable the sensor, press and hold the appropriate button until the light goes off. To reactivate a disabled sensor, make sure liquid chemical is present in the tubing, press and hold the appropriate button again until the light turns on. To prime chemical pumps, run nine (9) cycles without dishes. If the sensor is enabled while tubing is empty, the chemical sensor module may not operate properly.

Keep sufficient chemical supplies on hand to replenish as necessary.

## CHEMICAL SENSING MODULE — TO RECALIBRATE SENSORS

Make sure liquid chemical is present in the sensing tube. Press and hold the appropriate button until the light turns off. Press and hold the button again until the light comes on continuously to indicate the presence of liquid chemical in the tubing. If chemical is present and LED's are flashing, contact Hobart Service.

## CHEMICAL SENSING MODULE — TROUBLESHOOTING

PROBLEM	POSSIBLE CAUSE
Improper chemical indication.	Replenish chemical supplies.
Flashing when chemical is present.	Recalibrate sensor(s).
LED lit continuously, tubing is empty.	Verify liquid chemical is present in the tube and recalibrate sensor(s).
If the module cannot be manually recalibrated or if recalibration does not fix the problem.	Contact Hobart Service.