

**OPERATOR**

# *HAND WRAP STATION*

## *MODEL*

<i>W3-2C</i>	<i>ML-44105, ML-26331</i>
<i>W3-2</i>	<i>ML-44103, ML-26320</i>
<i>625A</i>	<i>ML-44069</i>



701 S. RIDGE AVENUE

TROY, OHIO 45374-0001

937 332-3000

[www.hobartcorp.com](http://www.hobartcorp.com)

FORM 25177 (May 2005)

# OPERATION AND CARE OF MODEL 625A, W3-2, AND W3-2C WRAP STATIONS

## GENERAL

The 625A, W3-2, and W3-2C are hand wrapping stations for use with PVC films. The hand wrapping stations accommodate 1 or 2 rolls of PVC stretch wrap film (3" diameter core) up to 20" wide.

Film is cut by a heated cut-off rod which melts the film on contact. Packages are sealed with the thermostatically controlled hot plate if applicable.

Adjustable feet (W3-2 and W3-2C only) provide leveling, stability, and/or minor height adjustment.

## 625A

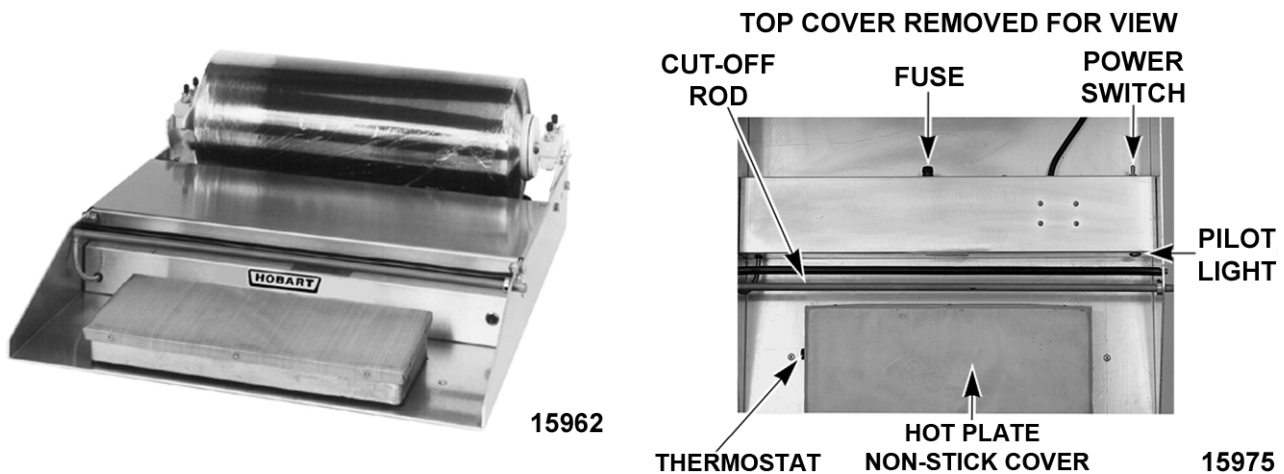
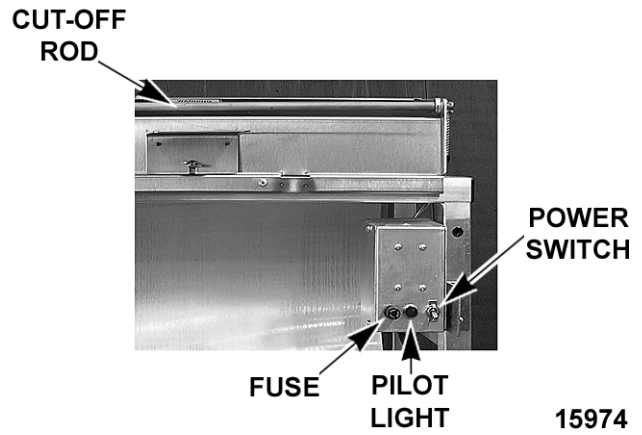

Table top unit with 6" x 15" hot plate.

Single roll of film with a capacity 12 to 20 inches.

## W3-2



Floor unit with up to 2 rolls of film with a capacity 12 to 20 inches.

Optional 6" x 15" hot plate (not shown).

Optional side shelves (not shown).

## W3-2C

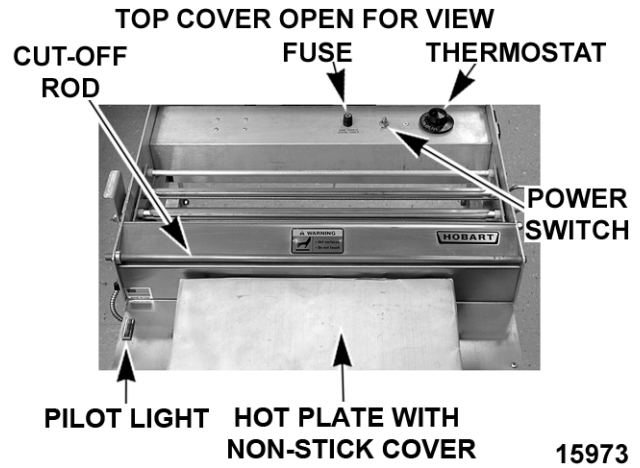

Floor unit with 8" x 15" hot plate.

Up to 2 rolls of film with a capacity 12 to 20 inches.

Optional side shelves (not shown).

# W3-2 and W3-2C FILM LOADING AND THREADING

**WARNING:** HOT PLATE AND CUT-OFF ROD ARE HOT, DO NOT TOUCH.

1. Loosen wing nuts which secure upper bearing blocks.

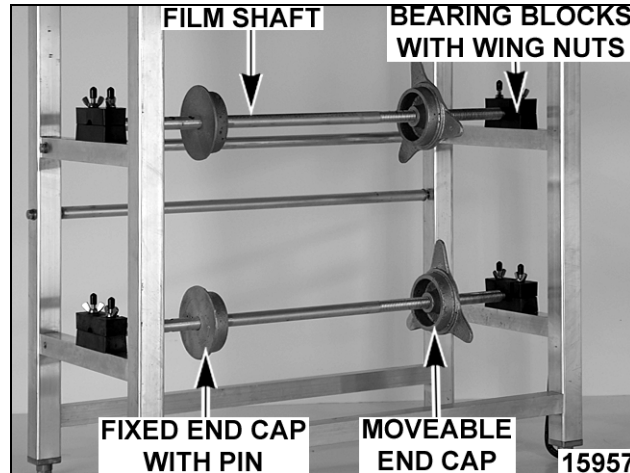

2. Rotate the upper bearing blocks to permit removal of the film shaft.
3. Remove film shaft from the bearing blocks.
4. Unscrew movable end cap.
5. Position fixed end cap to allow the film to be centered on the film shaft and secure with pin.
6. Slide the roll of film onto the film shaft and position the cardboard core of the film roll against the fixed end cap.
7. Replace the moveable end cap and tighten to secure the film roll. The film should now be centered on the film shaft, if not, adjust the fixed end cap position on the shaft as needed (step 4 thru 7).
8. Replace film shaft with film onto the lower bearing blocks so that the film will unwind from the top of the roll and toward the rear of the hand wrap station as shown below. Swing the upper bearing blocks back into place.

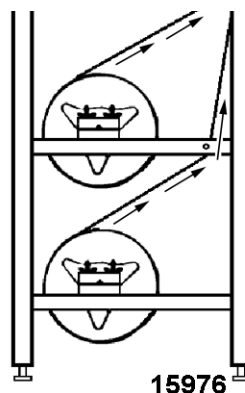

9. Route the film around the roller(s) as shown below.

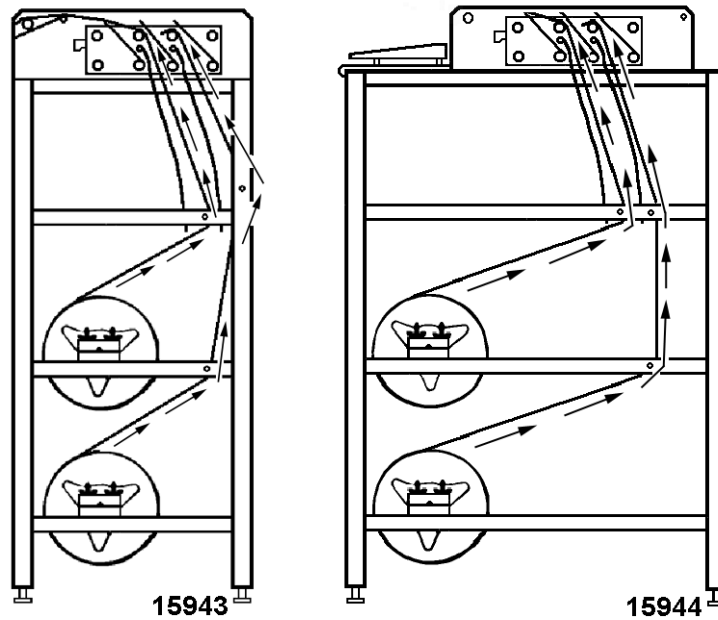

10. Raise top cover of hand wrap station to allow access to the film selector.

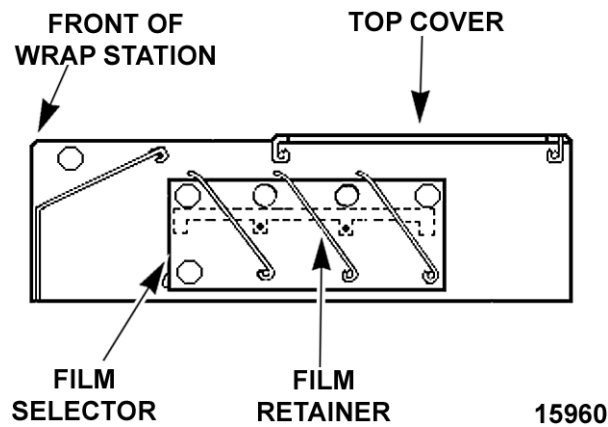

11. Raise film retainer on film selector and pull film through the film selector. Lower the film retainer to hold the film in place
12. Repeat procedure for other roll of film.
13. Lower the top cover.
14. Tighten and adjust the bearing block wing nuts for desired film tension.

**NOTE:** The amount of drag is generally a matter of operator preference, however sufficient tension must be maintained to provide proper film cutting.

# CHANGING FILM WIDTHS

1. Lift up both handles as shown below.

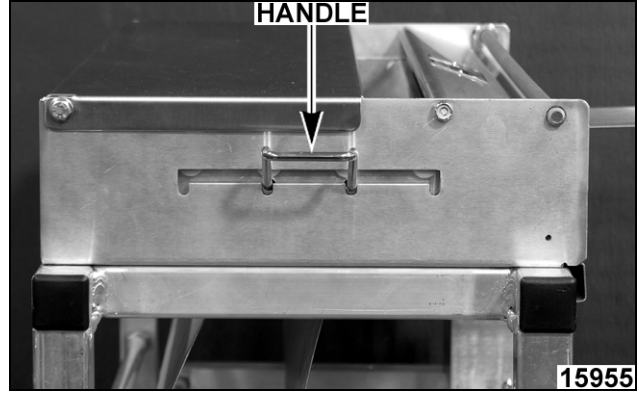
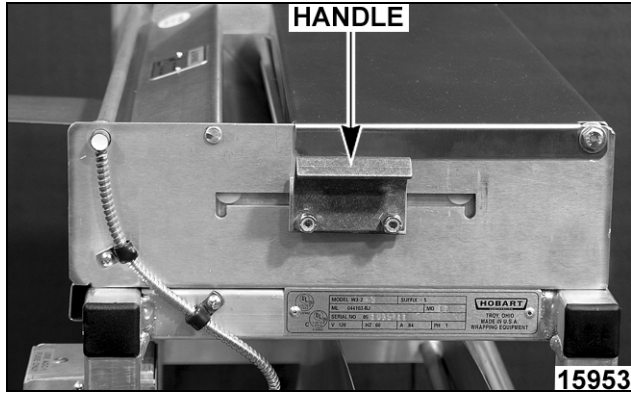

2. Move evenly forward or backwards.
3. Lower into slots.

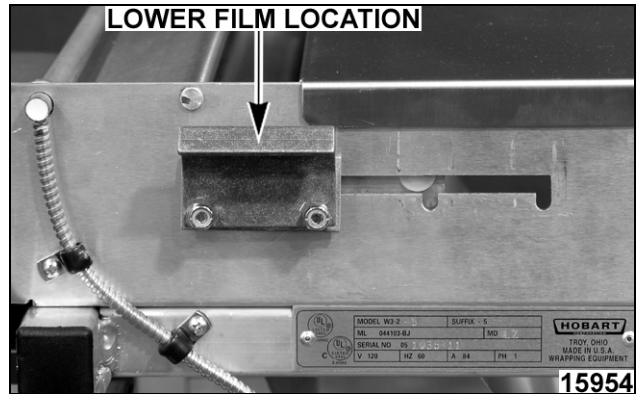
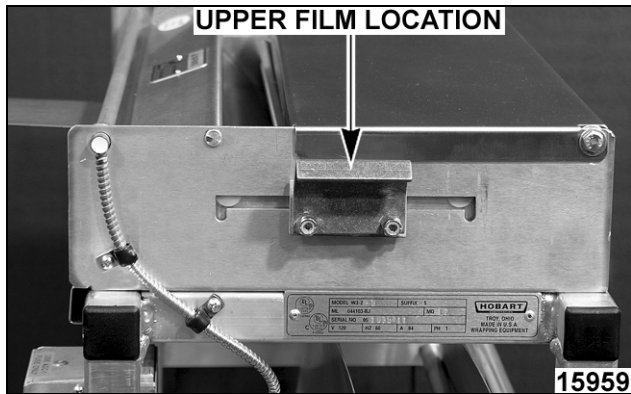

# 625A FILM LOADING AND THREADING

**WARNING:** HOT PLATE AND CUT-OFF ROD ARE HOT, DO NOT TOUCH.

1. Loosen wing nuts which secure upper bearing blocks.

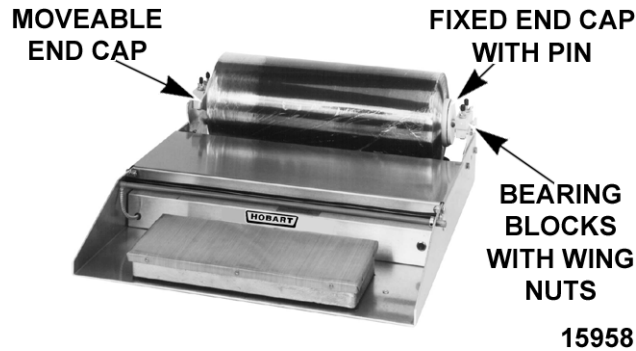

2. Rotate the upper bearing blocks to permit removal of the film shaft.
3. Remove film shaft from the bearing blocks.
4. Unscrew movable end cap.
5. Position fixed end cap to allow the film to be centered on the film shaft and secure with pin.
6. Slide the roll of film onto the film shaft and position the cardboard core of the film roll against the fixed end cap.
7. Replace the moveable end cap and tighten to secure the film roll. The film should now be centered on the film shaft, if not, adjust the fixed end cap position on the shaft as needed (step 4 thru 7).
8. Replace film shaft with film onto the lower bearing blocks so when you pull the film, it will unroll from the bottom as shown below. Rotate the upper bearing blocks back into place.

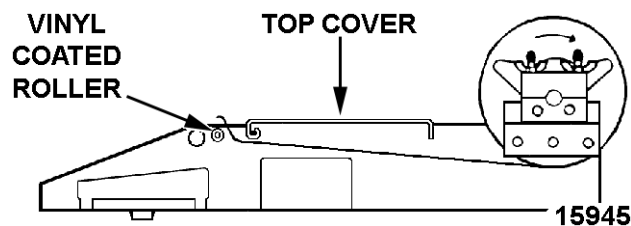

9. Raise top cover of hand wrap station to allow access to the film.
10. Route the film over the top of the vinyl coated roller, as shown above, and lower the top cover.
11. Tighten and adjust the bearing blocks wing nuts for desired film tension.

**NOTE:** The amount of drag is generally a matter of operator preference, however sufficient tension must be maintained to provide proper film cutting.

# WRAPPING PACKAGES

Plug in and turn on the power switch on unit. Allow 10 – 15 minutes for the temperature to stabilize on the cut-off rod and hot plate (if applicable).

**WARNING:** HOT PLATE AND CUT-OFF ROD ARE HOT, DO NOT TOUCH.

1. Place item to be wrapped on top cover of the wrap station.

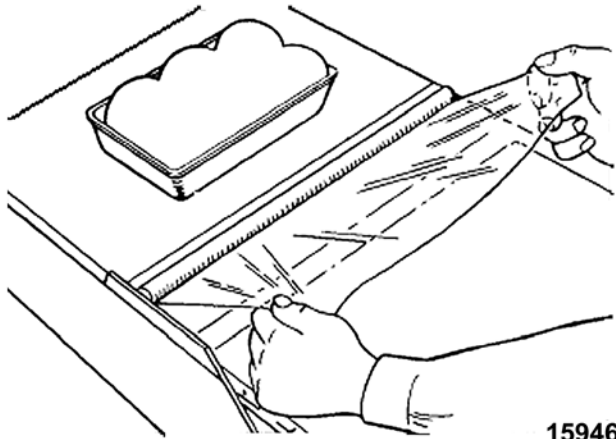

2. In a continuous motion:

- A. Pull the film up and over the item to be wrapped and tuck 2-3" under the far edge of the package.

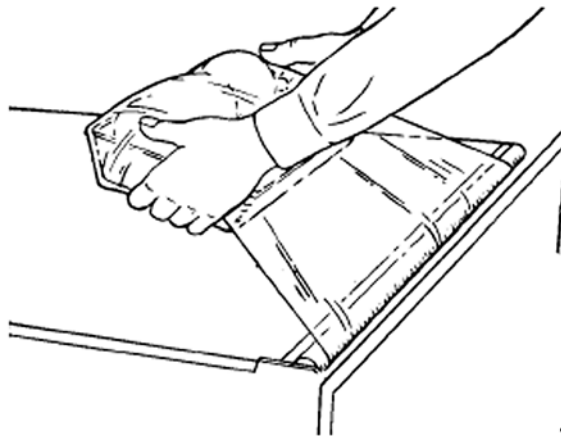

- B. Pick up the package by its sides, pull it back over the cut-off rod, and then down across the cut-off rod to cut the film.

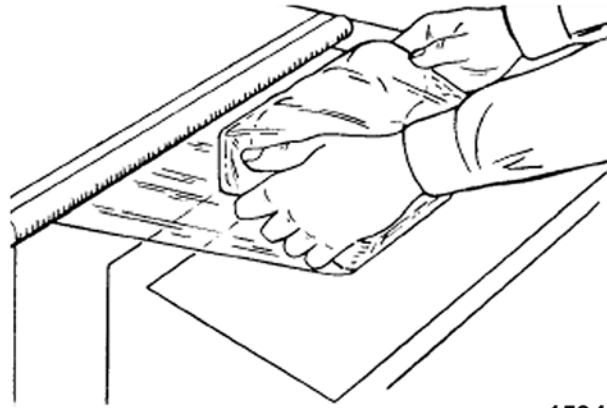

15948

- C. Stretch film over the sides and fold the excess under the package.

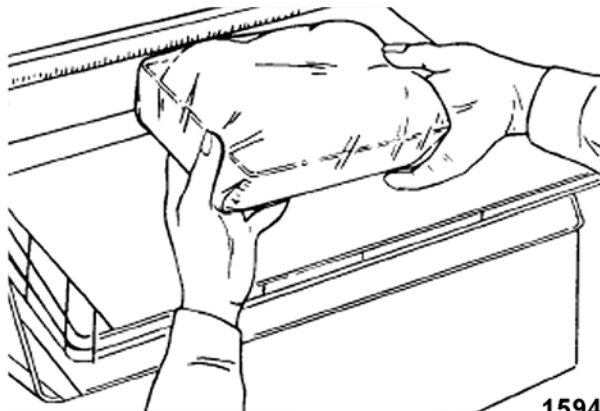

15949

3. Place the package briefly on the hot plate to seal the bottom.
4. Adjust thermostat for proper sealing temperature if needed.

# CLEANING



**WARNING:** DISCONNECT THE ELECTRICAL POWER TO THE MACHINE AND FOLLOW LOCKOUT / TAGOUT PROCEDURES.

**WARNING:** DO NOT HOSE DOWN UNIT.

**WARNING:** SURFACES MAY BE HOT.

The hand wrap station and hot plate cover should be cleaned with a mild detergent (dish soap) solution and a clean cloth.

**NOTE:** Harsh or high chlorine content cleaners will damage the stainless steel surfaces.

The cut-off rod can be cleaned with a non abrasive pad after the cut-off rod has cooled down.

# MAINTENANCE

Replace hot plate cover as needed.

# TROUBLESHOOTING

SYMPTOM	POSSIBLE CAUSE
1. Film sticks to hot plate.	Missing or worn non-stick cover. Replace cover as needed.
2. Package sealing is incomplete.	Increase time for package on hot plate.  Adjust thermostat to increase temperature of hot plate. After adjusting the temperature of the hot plate, please allow 10 – 15 minutes for the temperature to stabilize.
3. Holes in bottom of package.	Decrease time for package on hot plate.  Adjust thermostat to decrease temperature of hot plate. After adjusting the temperature of the hot plate, please allow 10 – 15 minutes for the temperature to stabilize.
4. Hot plate is cold.	Adjust thermostat to increase temperature of hot plate. After adjusting the temperature of the hot plate, please allow 10 – 15 minutes for the temperature to stabilize.  Check power switch to insure that power is on. When power is on, the pilot light should be illuminated.  Check cord and plug to assure electric supply is properly connected.
5. Cut-off rod is cold.	Check power switch to insure that power is on. When power is on, the pilot light should be illuminated.  Check cord and plug to assure electric supply is properly connected.  Check fuse.

Contact your local Hobart service office for any repairs or adjustments needed on this equipment.