



SERVICE MANUAL

WS-500 Water Softening System Installation Instructions

WS-500



19981

- NOTICE -

This Manual is prepared for the use of trained Hobart Service Technicians and should not be used by those not properly qualified.

This manual is not intended to be all encompassing. If you have not attended a Hobart Service School for this product, you should read, in its entirety, the repair procedure you wish to perform to determine if you have the necessary tools, instruments and skills required to perform the procedure. Procedures for which you do not have the necessary tools, instruments and skills should be performed by a trained Hobart Service Technician.

The reproduction, transfer, sale or other use of this Manual, without the express written consent of Hobart, is prohibited.

This manual has been provided to you by ITW Food Equipment Group LLC ("ITW FEG") without charge and remains the property of ITW FEG, and by accepting this manual you agree that you will return it to ITW FEG promptly upon its request for such return at any time in the future.

TABLE OF CONTENTS

GENERAL INFORMATION WS-500	3
GENERAL WS-500	3
BY PASS OPTIONS	4
BY- PASS VALVE KIT WS-500	4
BY- PASS VALVING WS-500	8
INSTALLATION	10
INSTALLATION WS-500	10
BRINE DRUM SETTINGS FOR WS-500	12
DISC REPLACEMENT	14
DISC REPLACEMENT WS-500	14
DISC SELECTION	16
DISC SELECTION WS-500	16

GENERAL INFORMATION WS-500

GENERAL WS-500



WARNING Disconnect the electrical power to the machine and follow lockout / tagout procedures.

1. Determine location to install equipment. Make sure the unit will be on a flat surface.
2. If sand, silt, or turbidity is present, install a separate prefilter.

NOTE: Sediment filtration is recommended before the water softener, particularly in areas with known sediment issues or on a private water supplies.

NOTE: If the peak flow rate required is unknown, a prefilter with a minimum of 1.25" connections should be used. Filters with 5 micron nominal ratings should be considered the standard in food service applications.

3. If the optional by-pass valve kit is being installed, follow steps listed under BY- PASS VALVE KIT WS-500 . If bypass valve kit is not being installed proceed to BY- PASS VALVING WS-500.

BY PASS OPTIONS

BY- PASS VALVE KIT WS-500



WARNING Disconnect the electrical power to the machine and follow lockout / tagout procedures.

1. To install by-pass valve determine which port on the by-pass valve (Port A or Port B) to plumb the raw water connection to.

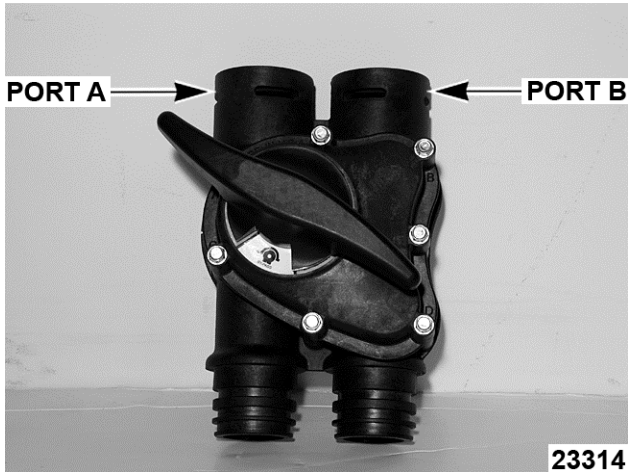

Fig. 1

2. Determine which port on the by-pass valve (Port C or Port D) to connect the softener.

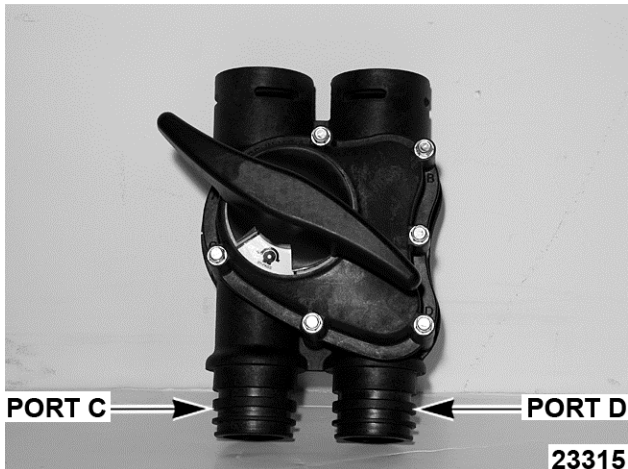

Fig. 2

3. Verify the by-pass valve is in the by-pass position. Turn by-pass handle to reveal yellow by-pass segment.

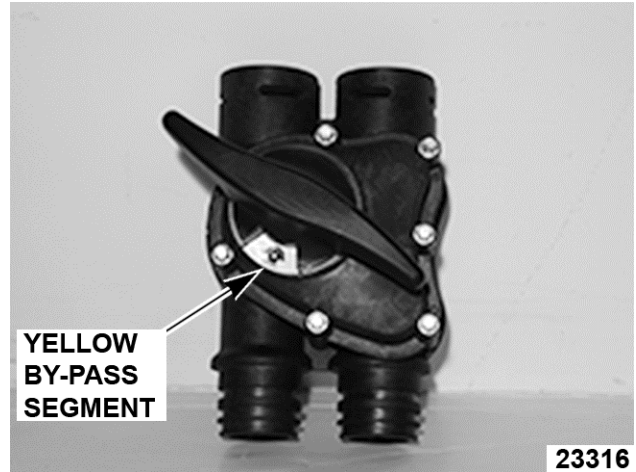

Fig. 3

4. Remove the by-pass valve handle by pulling it away from the by-pass valve body.

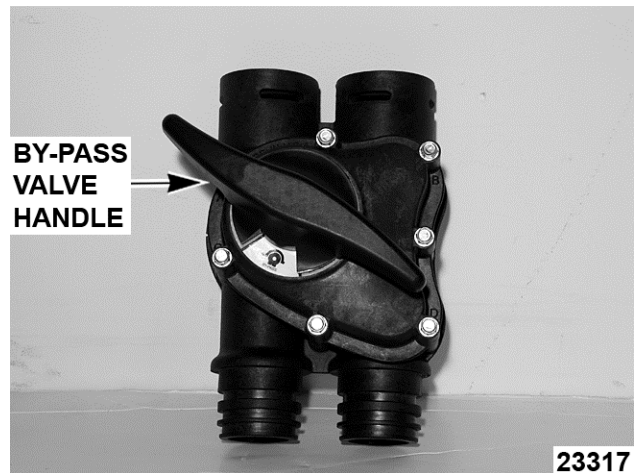

Fig. 4

5. The five position valve has two installation configuration options. Photo below shows the crossover and parallel configurations as the valve is shipped.

NOTE: When installing the five position valve - be certain to select the proper mode and install configuration (parallel or crossover).

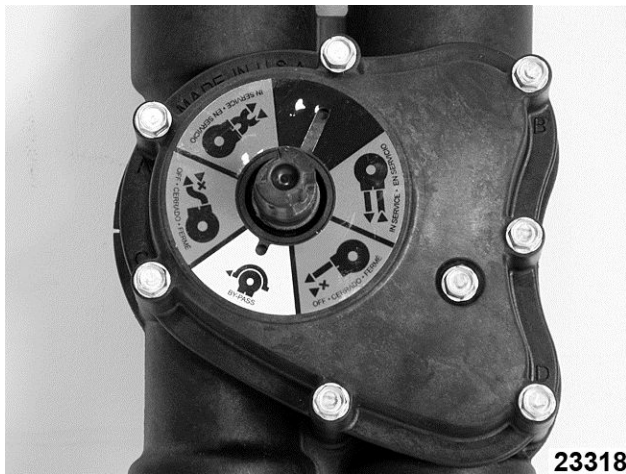
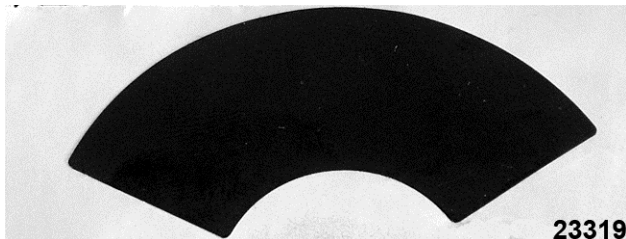

Fig. 5

6. Locate patch decal provided with by-pass valve kit.
7. Remove patch decal from paper lining and apply to body of the by-pass valve based on the specific installation using BY- PASS VALVE DECAL TABLE.

NOTE: For use in A-D or B-D configuration, it will be necessary to cut patch.



Patch Decal

8. Align the handle with the shaft until handle slides onto shaft. Push down on handle until it snaps into place.

NOTE: The handle is keyed allowing it to go on the shaft only one way. Failing to perform above procedure can result in breaking the shaft inside the handle. Do not force handle onto shaft.

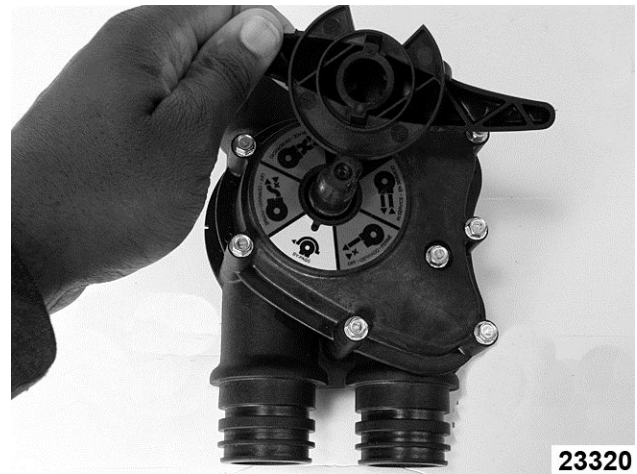

Fig. 7

NOTE: When installing a plastic component in line, it is recommended that grounding straps be put in place before the lines are actually cut to ensure the ground is never broken.

9. Prepare plumbing by roughing in.
10. Connect the inlet/outlet adapters to the plumbing. Solder or glue adapters to pipe as applicable.

NOTE: Do not solder adapters while in the by-pass valve.

NOTE: Care should be taken during the installation process to assure that solder flux does not come in contact with the media tanks, the control module, and related components.

11. After all plumbing is completed and before connecting any equipment, flush both inlet and outlet lines by opening the raw water inlet valve and allowing water to rinse out and debris in the line.
12. Close the raw water line when complete.
13. Locate from the by-pass kit the two elbows, four O-rings, two E-Clips and silicone packet.

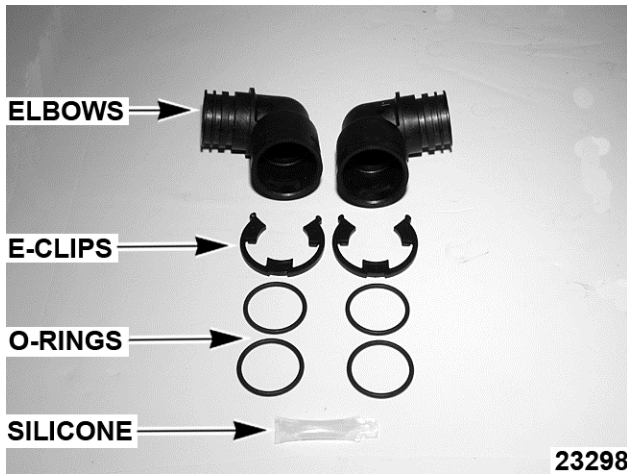

Fig. 8

14. Apply a liberal amount of silicone to the four Orings and install on the two end spaces on both Port C and Port D of the By - Pass Valve.

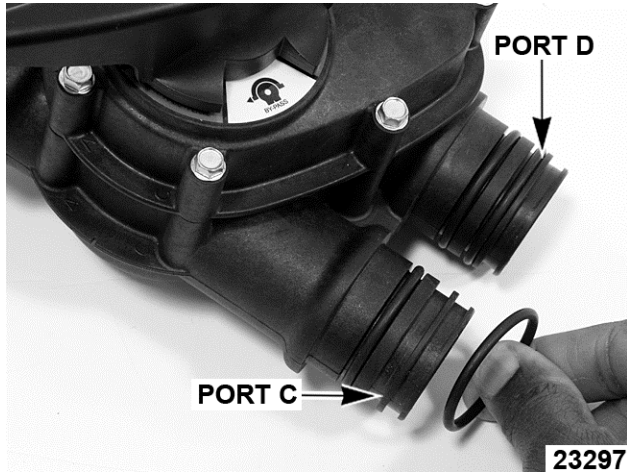

Fig. 9

15. Insert mesh screens into left and right elbows.

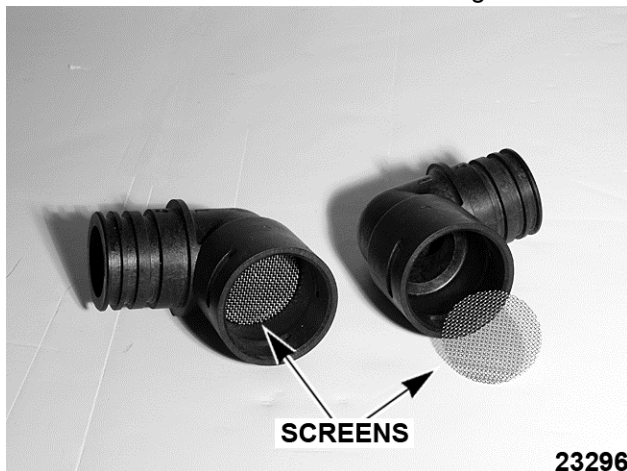

Fig. 10

16. Locate from the by pass kit the four O-rings, two E-Clips and silicone packet

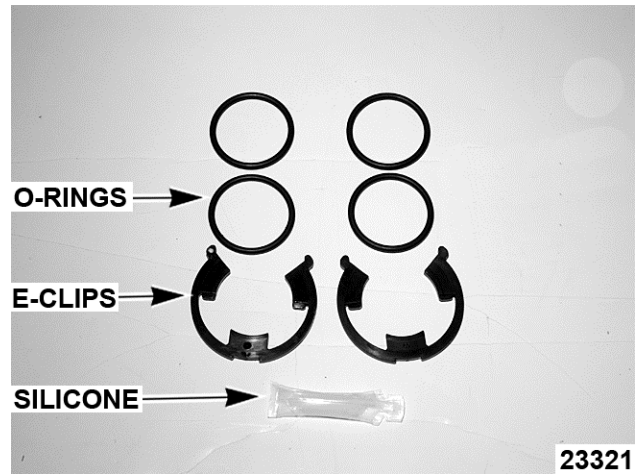

Fig. 11

17. Apply a liberal amount of silicone to the four Orings and install on the two outermost grooves on both elbows

NOTE: Elbows are marked left (L) and right (R). When applying to by-pass valve be certain to install in correct location based on left/right orientation.

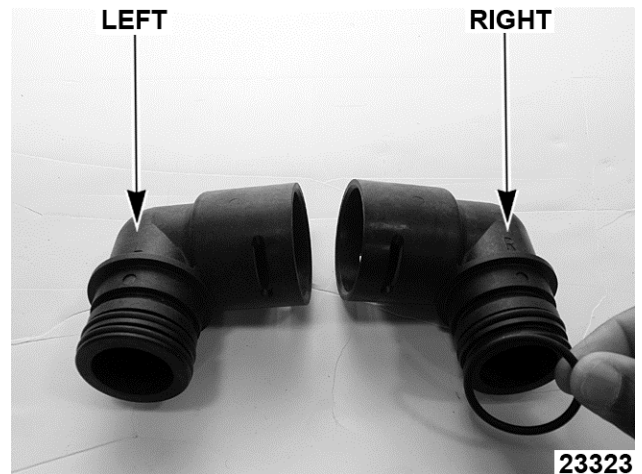

Fig. 12

NOTE: Make sure to align the center slot (the slot with the small triangle underneath it) with the outside of the by pass valve.

18. Connect elbows from the by-pass valve to softener using E-clips. Press E-clips until they securely snap in place.
19. Connect the by-pass valve to the inlet/outlet adapters. Press E-clips until they securely snap in place.
20. Plumb as necessary to accommodate the bypass valve and to complete the installation.

21. Locate enclosed kit containing four O-rings, two pipes with O-rings, and the silicone packet. Apply a liberal amount of silicone to the four Orings and the O-rings in the two pipes. Install the four O-rings to the inlet/outlet adapters.

NOTE: Be certain the E-clips are fully inserted into the valve. Check to make sure that all three tabs on the E-clips are fully inserted.

Typical Installation

Typical Installation

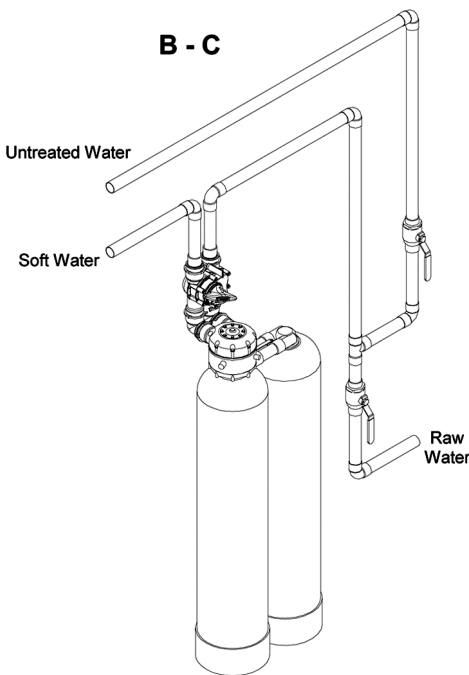
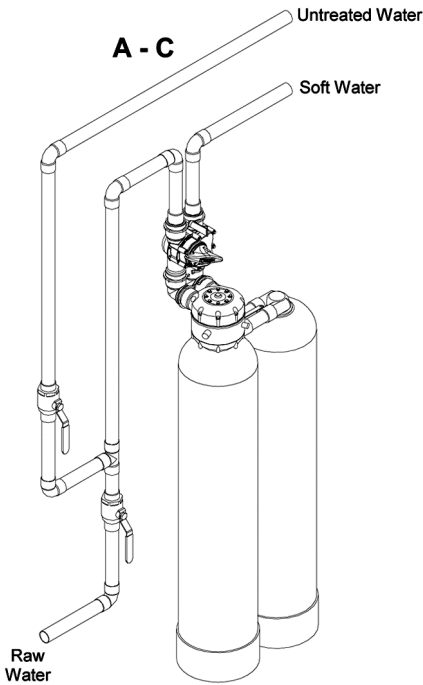

Fig. 13

AI3176



AI3177

Fig. 14



Figure 2
A - C



Figure 3
B - C

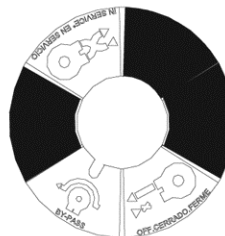

Figure 4
A - D

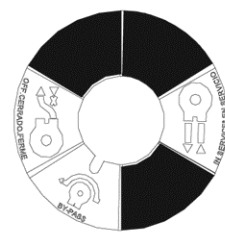

Figure 5
B - D

A13175

Fig. 15

BY- PASS VALVE DECAL TABLE				
MODE	RAW INLET	SOFTENER INLET	INSTALL CONFIGURATION	FIG
A-C	A	C	PARALLEL	2
B-C	B	C	CROSSOVER	3
A-D	A	D	CROSSOVER	4
B-D	B	D	PARALLEL	5

BY- PASS VALVING WS-500

NOTE: If optional by-pass valve kit is not installed - it is recommended that by-pass valving be installed. To install by-pass valving - follow steps listed below.

1. Install by-pass valving. Be certain to note the inlet and outlet arrows on the valve head.
2. Connect the inlet/outlet adapters leading to the softener using the proper size plumbing.
3. Plumb as necessary to accommodate the bypass valving and to complete the installation.

NOTE: Actual installation of by-pass valving may vary from installation to installation. Be sure to follow state and local codes.

NOTE: When installing a plastic component in line, it is recommended that grounding straps be put in place before the lines are actually cut to ensure the ground is never broken.

NOTE: Do not solder brass adapters while inserted in the module base. Damage to plastic and rubber parts may result due to the heat. In addition, the materials used in the soldering process may attack certain types of plastics.

NOTE: Care should be taken during the installation process to assure that solder flux do not come in contact with the media tanks, the control module, and related components.



Fig. 16

4. After all plumbing is completed, but before connecting equipment, flush both the inlet and outlet lines by opening the by-pass valve and allowing water to rinse out any debris in the lines.
5. Connect the main tank with softener valve to the inlet/outlet adapter. The inlet/outlet adapter is inserted into the control valve and locked in place by the plastic E-clips.

INSTALLATION

INSTALLATION WS-500



WARNING Disconnect the electrical power to the machine and follow lockout / tagout procedures.

1. Connect the remote tank to the main tank using connector pipes, connector links and connector pins.

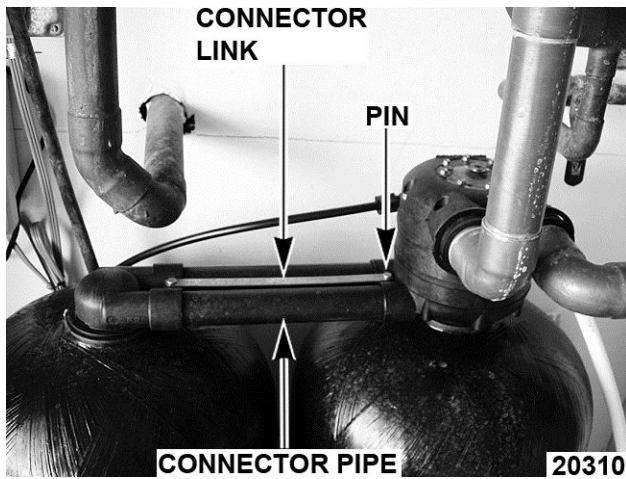

Fig. 17

NOTE: Always use both links and pins.

2. Run a drain line to the discharge point.

NOTE: Follow state and local codes.

3. Before connecting unit, check for obstructions or kinks. Apply Teflon tape to pipe threads on side of softener valve, and install the two fittings supplied. Connect drain line to valve.

NOTE: An air gap must be provided for all drain lines. Check state and local plumbing codes for proper setup of drain line air gaps.

NOTE: On drain lines that must travel more than 8 feet up and 30 feet over, it is best to take the 5/8" drain line that fits the valve and attach it in a larger diameter line or pipe.

4. Position the brine drum.

NOTE: Brine drum should be conveniently positioned to allow salt to be added.



Fig. 18

5. To install salt alarm system - remove paper lining from back of salt alarm sensor.

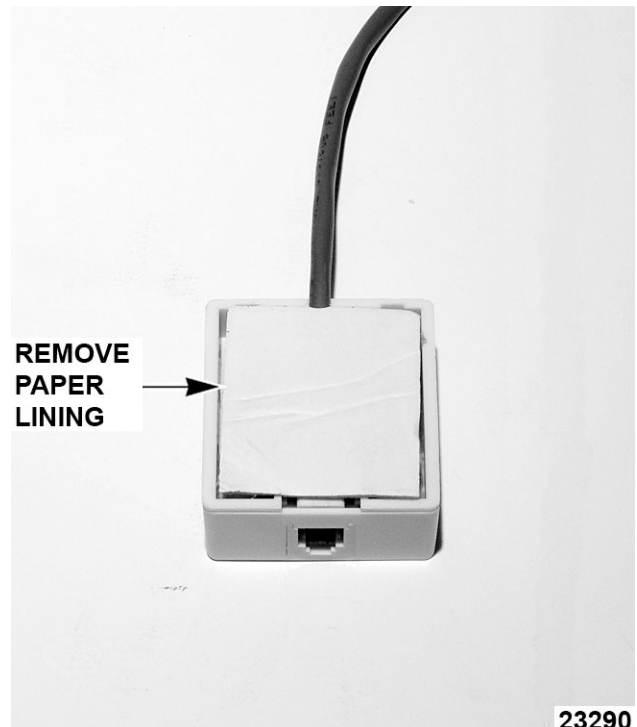

Fig. 19

- Remove plastic lining from Velcro® backing located on back of salt alarm controller.



Fig. 20

- Remove four screws securing back cover to salt alarm controller.



Fig. 21

- Install three (3) AA batteries into salt alarm controller.

NOTE: When installing batteries - be certain to inspect connector to ensure it is secure.

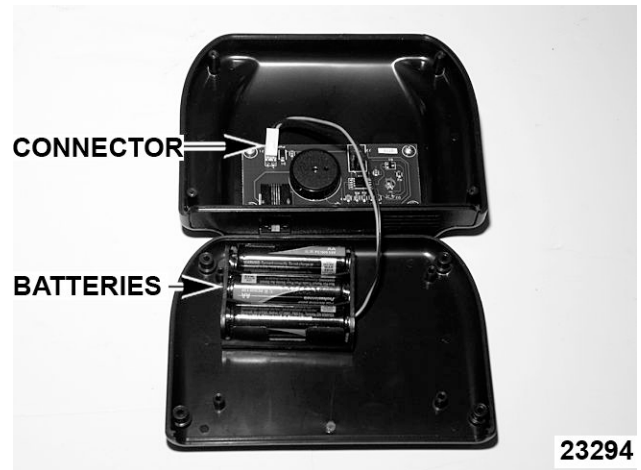

Fig. 22

- Re-install back cover to salt alarm controller.
- Using the adhesive backing on both devices - place alarm controller and salt alarm sensor in a position that will allow salt alarm controller to be seen and heard when it is activated.
- Insert phone cable into salt alarm sensor and salt alarm controller.

NOTE: Salt alarm controller can be mounted up to 100 feet from salt alarm connector box using standard phone cable from local retailers (7 foot cable is provide with kit).

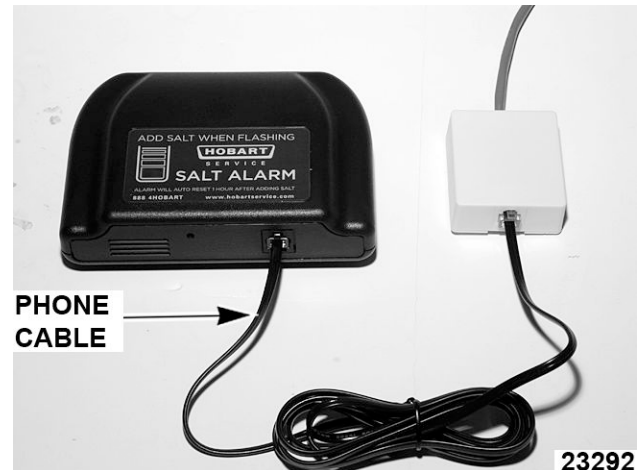
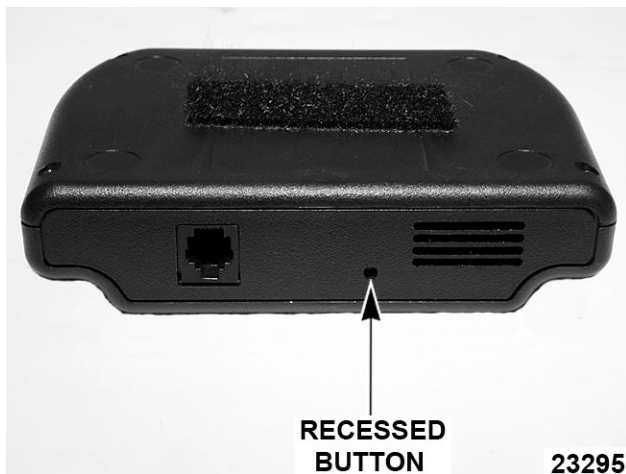

Fig. 23

- Check for proper operation by pressing the recessed red button on bottom of salt alarm controller. If controller is operating properly - the indicator light will flash and an audible tone will be heard.



RECESSED
BUTTON

23295

Fig. 24

BRINE DRUM SETTINGS FOR WS-500

NOTE: In Hobart Softeners, the brine drum mixes and stores a solution of salt for regeneration of the softener media. During the brine rinse cycle, this solution is drawn from the brine drum and through the media to regenerate it.

NOTE: The brine drum contains an adjustment to draw the correct amount of salt (brine) solution for each cycle. This adjustment is made in two places, the adjuster tube and the float cup.

NOTE: The adjuster tube measures the amount of solution that is drawn from the brine drum into the softener during the brine rinse cycle. The float cup height determines how much softened water flows back into the brine drum to prepare for the next regeneration.

NOTE: The adjuster tube is set by cutting and removing tabs on both sides of the tube. Cut across each tab horizontally, following the channel in the plastic. Break off each tab individually until the proper setting is reached. The remaining number or letter imprinted on the tab determines the correct setting.

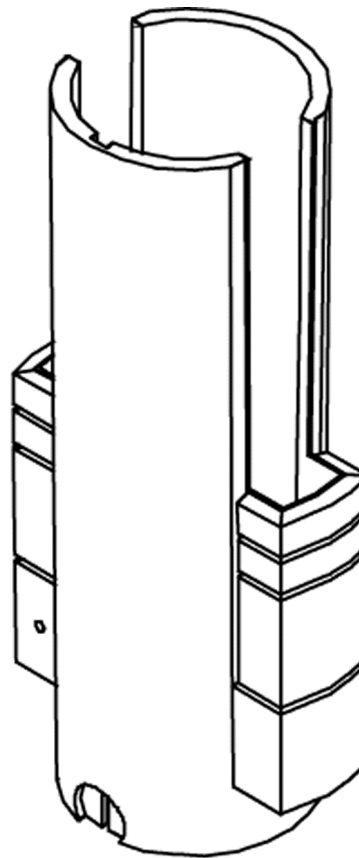

Adjuster Tube

AI2317

Fig. 25

NOTE: The float cup height determines how much softened water flows back into the brine drum to prepare for the next regeneration.

NOTE: The float cup is set by adjusting its height above the bottom of the Brine Valve Assembly. By removing the brine valve assembly and resting it on a flat surface, the height of the float cup can be measured with a ruler. The height is measured from the base of the brine valve assembly to the top of the float cup.

NOTE: Standard settings are defined by markings on the rod of the brine valve assembly. Where the predefined settings are not adequate, the actual float cup height must be measured and the setting must be measured and set according to the measured float cup height.

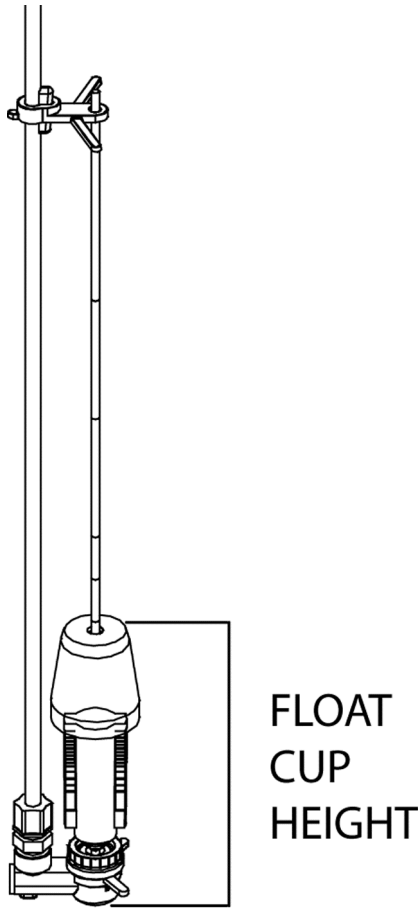

Brine Valve Settings for WS-500: 24 x 40 Brine Valve Adjustment	
Adjuster Tube	K
Float Cup	12"

NOTE: Do not drop the brine valve into the drum. Dropping may lower the float cup, resulting in an improper setting.

NOTE: After the adjustments have been made to the adjuster tube and the float cup, the brine valve assembly must be installed in the brine drum. Locate the brine valve in the brine well so the 3/8" bent tube is along the back of the brine well away from the brine drum wall. The 3/8" bent tube snaps into a notch and extends from the brine drum about 1 inch.

AI2318

Fig. 26

NOTE: Determining the correct brine valve setting for a particular application is a three step process:

1. Determine the compensated hardness. This requires a hardness test and an iron test on raw water at the application site. Compensated hardness is calculated by multiplying the ferrous iron (in ppm) by 3 and adding it to the grains of hardness.
2. To test the water supply, use the water analysis test kit available through Pro Products Inc. The recommended kit is #2404 Deluxe Field Analysis Kit. To order the test kit contact Pro Products at 800-285-9176 or visit www.ProProducts.com
3. Set the adjuster tube and float cup. Use the brine drum specifications for the WS-500 to determine the correct settings for both the adjuster tube and the float cup height.

Brine Valve Settings for WS-500: 24 x 40 Brine Valve Adjustment	
Salt Setting	25 lbs.

DISC REPLACEMENT

DISC REPLACEMENT WS-500

NOTE: The WS-500 comes with a #4 meter disc installed at the factory. If this is not the correct disc for a given application, locate the meter disc kit and install the correct disc

1. To change disc, remove screws and cap cover from level one

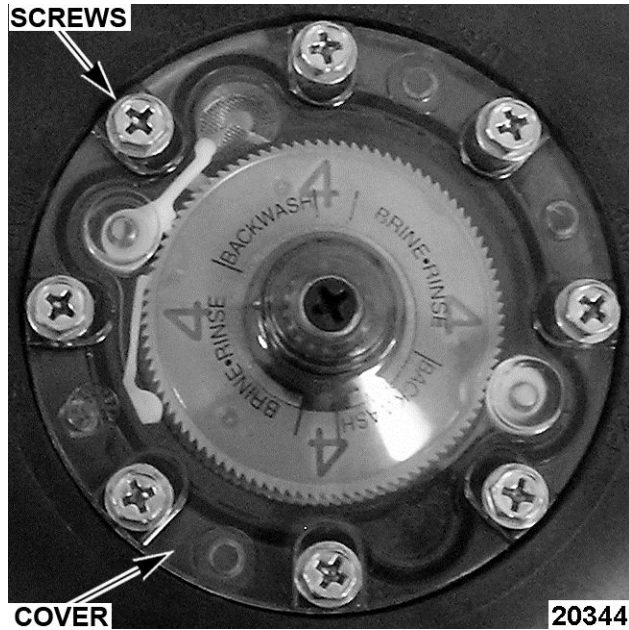

Fig. 27

2. Remove balance piston.

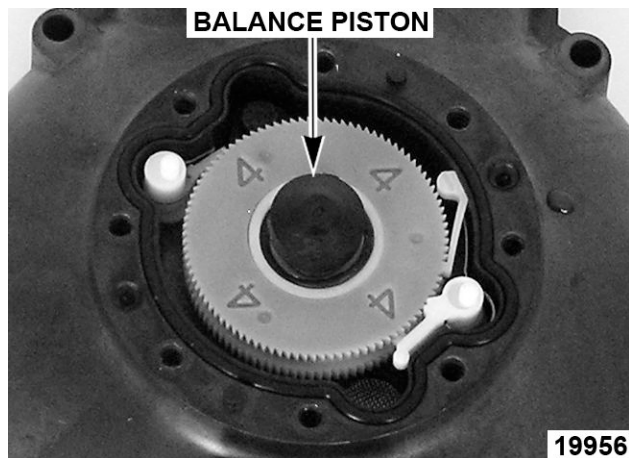

Fig. 28

3. Remove balance piston o-ring and balance piston spring.

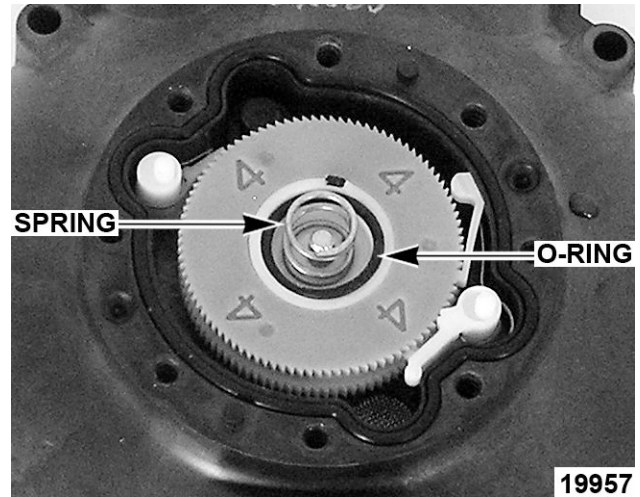

Fig. 29

4. Remove meter drive pawl.

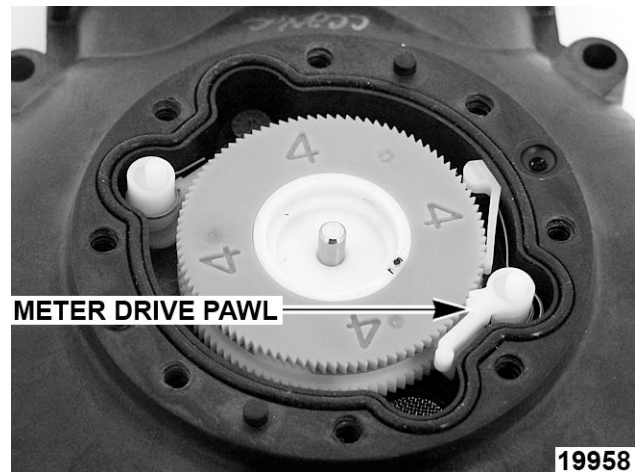

Fig. 30

5. Remove meter disc.

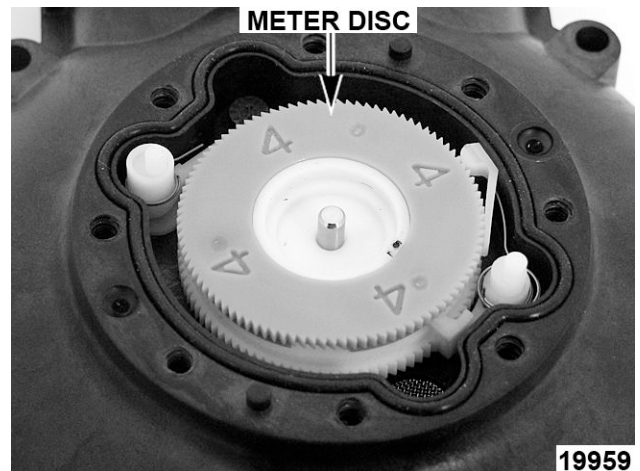

Fig. 31

6. Install correct meter disc and reassemble in reverse order.

NOTE: Make certain all components are correctly installed.

NOTE: Be certain to start cap screws by hand rotating backwards until screw drops into thread then tighten. An alternating, crossing pattern should be used while tightening cap screws to ensure correct cap fit. Add a clean grade of salt at this time. Higher grades of Pelletized Salt for impurities and solubility should be used.

NOTE: Do not use rock salt or solar salt.

NOTE: On iron-bearing water, a salt that contains resin cleaning additives is recommended.

7. Open the inlet valve slowly and allow the tanks to fill slowly with water. Water will run at the drain until unit is full and pressurized.
8. With the unit in service and under pressure, allow the brine drum to fill with water until the brine valve shuts off.
9. After the unit is fully pressurized, purge air from the lines by opening soft water outlet.

NOTE: When brine drum overflow could cause damage, a ½" I.D. overflow line must be installed on the barbed overflow fitting on drum and connected to a drain. Make sure drain is not higher than barbed fitting.

10. Check for plumbing leaks.
11. Check unit for proper operation.

DISC SELECTION

DISC SELECTION WS-500

Using the full louver nozzle, the amount of hardness removed (in compensated gpg) will be based on the amount of brine and the meter disc selected.

Specifications WS-500	Overdrive Operation	Alternating Operation
Salt usage / generation	25 lbs.	25 lbs.
Capacity	70,00 grains	70,00 grains
Efficiency	2,800 gr./lb.	2,800 gr./lb.
Dosing	10.0 lbs./cu. ft.	10.0 lbs./cu. ft.
Float cup setting	12"	12"

OVERDRIVE OPERATION WS-500 Disc Selection								
Disc Number	1	2	3	4	5	6	7	8
Compensated Hardness *	6	12	16	20	24	30	35	40
Peak Flow During Regeneration	28.0	28.0	28.0	20.7	15.7	12.4	10.0	8.3
* Compensated hardness in gpg = Hardness + (3 x Fe in ppm)								

ALTERNATING OPERATION WS-500 Disc Selection								
Disc Number	1	2	3	4	5	6	7	8
Compensated Hardness *	7	14	21	28	34	40	45	51
Gallons Between Regeneration	8,922	4,461	2,974	2,231	1,784	1,487	1,275	1,115
Regeneration Gallons Per Minute @ 15 psig	20	20	20	20	15.7	12.4	10.0	8.3
* Compensated hardness in gpg = Hardness + (3 x Fe in ppm)								