



HOSHIZAKI

Service Manual

Self-Contained Cuber

Models

AM-50BAJ

AM-50BAJ-DS

AM-50BAJ-AD

AM-50BAJ-ADDS



hoshizakiamerica.com

Number: 73218
Issued: 12-18-2017
Revised: 5-23-2025

⚠ WARNING

Only qualified service technicians should install and service the appliance. To obtain the name and phone number of your local Hoshizaki Certified Service Representative, visit www.hoshizakiamerica.com. No service should be undertaken until the technician has thoroughly read this Service Manual. Failure to service and maintain the appliance in accordance with this manual will adversely affect safety, performance, component life, and warranty coverage and may result in costly water damage. Proper installation is the responsibility of the installer. Product failure or property damage due to improper installation is not covered under warranty.

Hoshizaki provides this manual primarily to assist qualified service technicians in the service of the appliance.

Should the reader have any questions or concerns which have not been satisfactorily addressed, please call, send an e-mail message, or write to the Hoshizaki Technical Support Department for assistance.

Phone: 1-800-233-1940; (770) 487-2331

E-mail: tech-support@hoshizaki.com

HOSHIZAKI AMERICA, INC.

618 Highway 74 South

Peachtree City, GA 30269

Attn: Hoshizaki Technical Support Department

NOTE: To expedite assistance, all correspondence/communication **MUST** include the following information:

- Model Number _____
- Serial Number _____
- Complete and detailed explanation of the problem.

IMPORTANT

This manual should be read carefully before the appliance is serviced. Read the warnings and guidelines contained in this manual carefully as they provide essential information for the continued safe use, service, and maintenance of the appliance. Retain this manual for any further reference that may be necessary.

CONTENTS

Important Safety Information	5
I. Construction and Water/Refrigeration Circuit Diagram	8
A. Construction	8
B. Water/Refrigeration Circuit Diagram	9
II. Sequence of Operation and Service Diagnosis	10
A. Sequence of Operation Flow Chart	10
1. Icemaker Flow Chart.....	10
2. Bin Control Shutdown Flow Chart	11
B. Service Diagnosis	12
1. Thermostat Bin Control	12
2. Thermistor Bin Control.....	17
C. Bin Control Check	23
1. Thermostat Bin Control - Auxiliary Code N-1 and Earlier	23
2. Thermistor Bin Control - Auxiliary Code N-2 and Later	24
D. Evaporator Thermistor Check.....	25
E. Diagnostic Tables	26
III. Control Board.....	29
A. Main and Thermistor Control Boards	29
1. Main Control Board Layout.....	30
2. Thermistor Control Board Layout	31
B. Main Control Board Settings and Adjustments	32
C. LED Lights	33
1. Main Control Board LED Lights.....	33
2. Thermistor Control Board LED Lights (Aux. Code N-2 and later)	33
D. Control Switch	33
IV. Refrigeration Circuit and Component Service Information.....	34
A. Refrigeration Circuit Service Information	34
B. Component Service Information.....	36
V. Maintenance	37
A. Maintenance Schedule.....	37
B. Optional Drain Pump HS-5061	38
VI. Preparing the Icemaker for Periods of Non-Use	39
VII. Disposal.....	40

VIII. Technical Information.....	41
A. Specification and Performance Data.....	41
1. AM-50BAJ(-DS)	41
2. AM-50BAJ-AD(ADDS)	42
B. Wiring Diagrams.....	43
1a) AM-50BAJ(-DS)(-AD)(-ADDS) Auxiliary Code J-0 and Earlier	43
1b) AM-50BAJ(-DS)(-AD)(-ADDS) Auxiliary Code J-1 to L-0.....	44
1c) AM-50BAJ(-DS)(-AD)(-ADDS) Auxiliary Code M-0 to M-2	45
1d) AM-50BAJ(-DS)(-AD)(-ADDS) Auxiliary Code N-0 to N-1	46
1e) AM-50BAJ(-DS)(-AD)(-ADDS) Auxiliary Code N-2 and Later.....	47
2) HS-5061 Optional Drain Pump.....	48

Important Safety Information

Throughout this manual, notices appear to bring your attention to situations which could result in death, serious injury, damage to the appliance, or damage to property.

⚠ WARNING Indicates a hazardous situation which could result in death or serious injury.

NOTICE Indicates a situation which could result in damage to the appliance or property.

IMPORTANT Indicates important information about the use and care of the appliance.

⚠ WARNING

The appliance should be destined only to the use for which it has been expressly conceived. Any other use should be considered improper and therefore dangerous. The manufacturer cannot be held responsible for injury or damage resulting from improper, incorrect, and unreasonable use. Failure to service and maintain the appliance in accordance with this manual will adversely affect safety, performance, component life, and warranty coverage and may result in costly water damage.

To reduce the risk of death, electric shock, serious injury, or fire, follow basic precautions including the following:

- Only qualified service technicians should install and service the appliance.
- The appliance must be installed in accordance with applicable national, state, and local codes and regulations. Failure to meet these code requirements could result in death, electric shock, serious injury, fire, or damage.
- To reduce the risk of electric shock, do not touch the control switch or plug with damp hands.
- Make sure the control switch is in the "OFF" position before plugging in or unplugging the appliance.
- Before servicing, move the control switch to the "OFF" position. Unplug the appliance from the electrical outlet.
- The appliance requires an independent power supply of proper capacity. See the nameplate for electrical specifications. Failure to use an independent power supply of proper capacity can result in a tripped breaker, blown fuse, damage to existing wiring, or component failure. This could lead to heat generation or fire.
- **THE APPLIANCE MUST BE GROUNDED:** The appliance is equipped with a NEMA 5-15 three-prong grounding plug  to reduce the risk of potential shock hazards. It must be plugged into a properly grounded, independent 3-prong wall outlet. If the outlet is a 2-prong outlet, it is your personal responsibility to have a qualified electrician replace it with a properly grounded, independent 3-prong wall outlet. Do not remove the ground prong from the power cord and do not use an adapter plug. Failure to properly ground the appliance could result in death or serious injury.
- The GREEN ground wire in the factory-installed power cord is connected to the appliance. If it becomes necessary to remove or replace the power cord, be sure to connect the power cord's ground wire.

⚠ WARNING, continued

- Do not make any alterations to the appliance. Alterations could result in electric shock, serious injury, fire, or damage.
- Do not use an extension cord.
- Do not use an appliance with a damaged power cord. The power cord should not be altered, jerked, bundled, weighed down, pinched, or tangled. Such actions could result in electric shock or fire. To unplug the appliance, be sure to pull the plug, not the cord, and do not jerk the cord.
- This appliance is not intended for use by persons (including children) with reduced physical, sensory, or mental capabilities, or lack of experience and knowledge, unless they have been given supervision or instruction concerning use of the appliance by a person responsible for their safety.
- Children should be properly supervised around this appliance.
- Do not climb, stand, or hang on the appliance or appliance door or allow children or animals to do so. Do not climb into the appliance or allow children or animals to do so. Death or serious injury could occur or the appliance could be damaged.
- Be careful not to pinch fingers when opening and closing the door. Be careful when opening and closing the door when children are in the area.
- Open and close the door with care. Door opened too quickly or forcefully may cause injury or damage to the appliance or surrounding equipment.
- Do not use combustible spray or place volatile or flammable substances near the appliance. They might catch fire.
- Keep the area around the appliance clean. Dirt, dust, or insects in the appliance could cause harm to individuals or damage to the appliance.
- Do not place anything on top of the appliance. Foreign objects or moisture could enter the appliance and result in electric shock or fire.

NOTICE

- Protect the floor when moving the appliance to prevent damage to the floor.
- When making water supply or drain line repairs, follow the requirements found in the instruction manual to reduce the risk of costly water damage.
- In areas where water damage is a concern, confirm appliance is installed in a contained area with a floor drain.
- Confirm the appliance is in a location that stays above freezing. Normal operating ambient temperature must be within 45°F to 100°F (7°C to 38°C).
- If using the optional drain pump ([HS-5061](#)), test its operation every time the appliance is cleaned and sanitized. See "V.B. Optional Drain Pump [HS-5061](#)" for details. If the optional drain pump is not operating properly, water could back up and overflow, leading to costly water damage.
- If water collects in the bin and will not drain, turn off the appliance and close the water supply line shut-off valve.
- If water seeps from the base of the appliance, turn off the appliance and close the water supply line shut-off valve. Failure to do so could lead to costly water damage.
- Do not leave the appliance on during extended periods of non-use, extended absences, or in sub-freezing temperatures. To properly prepare the appliance for these occasions, follow the instructions in "VI. Preparing the Appliance for Periods of Non-Use."
- Keep ventilation openings, in the appliance enclosure or in the built-in structure, clear of obstruction.
- Do not place objects on top of the appliance.
- The ice storage bin is for ice use only. Do not store anything else in the ice storage bin.

I. Construction and Water/Refrigeration Circuit Diagram

A. Construction

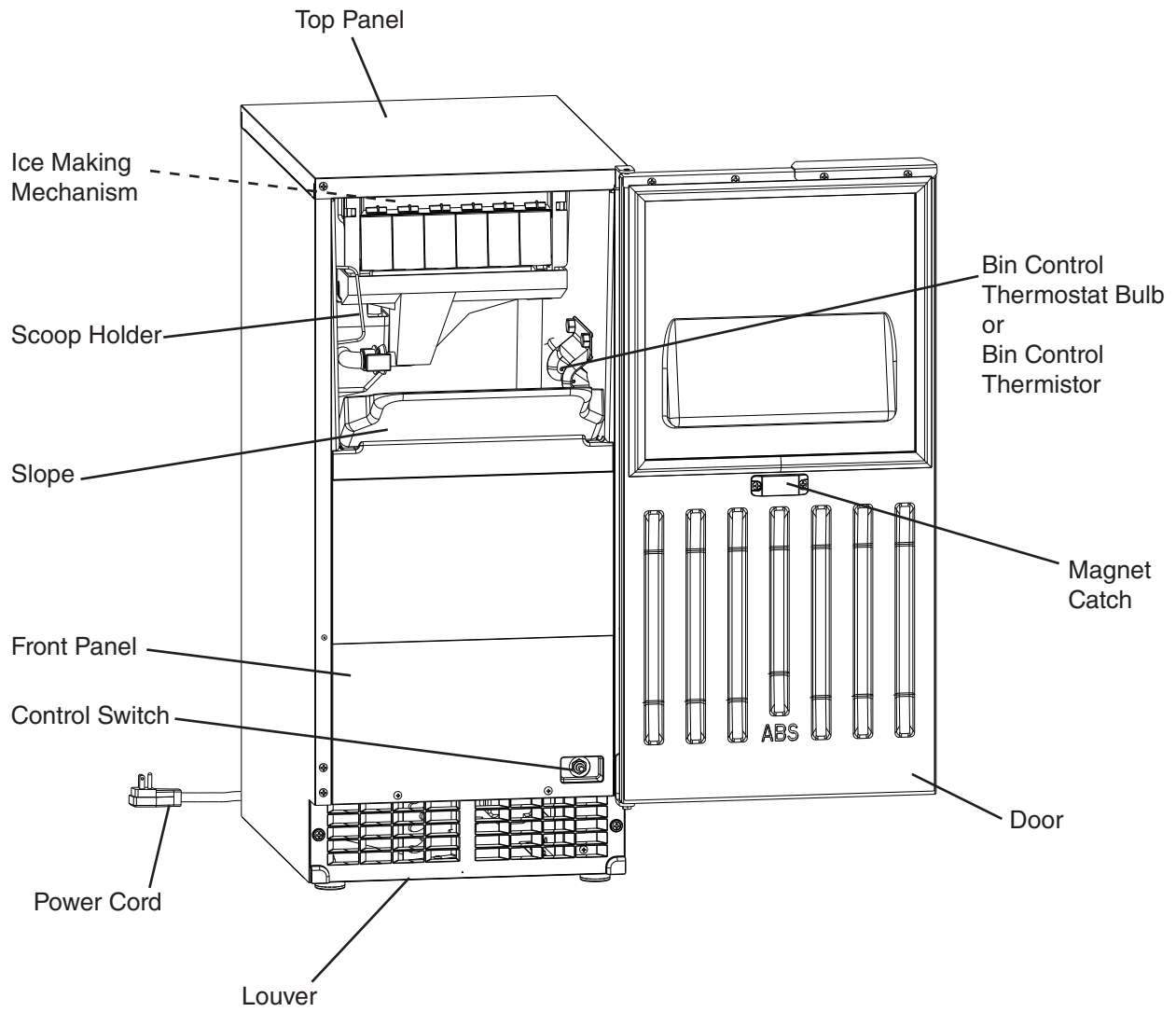

B. Water/Refrigeration Circuit Diagram

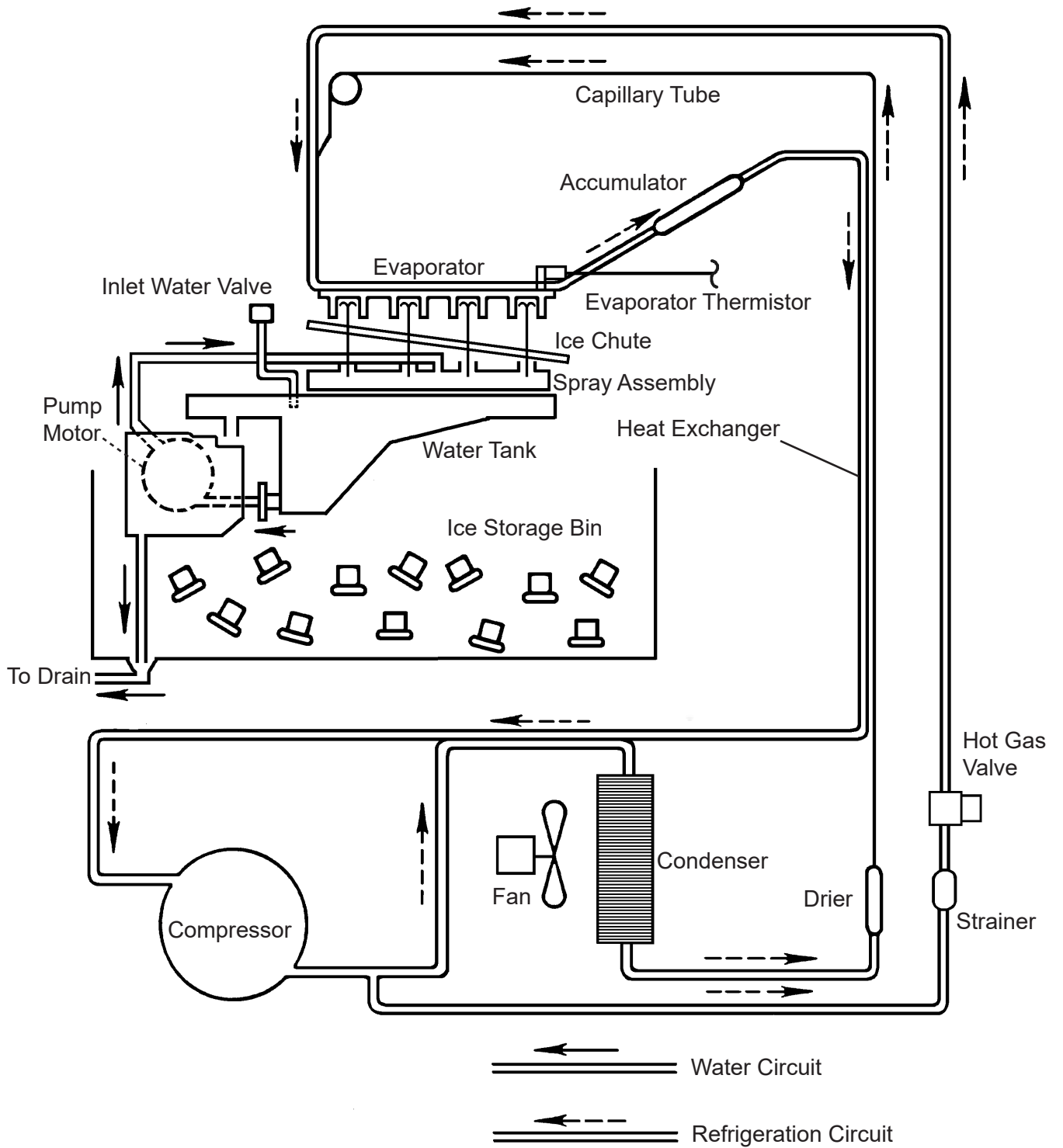

II. Sequence of Operation and Service Diagnosis

A. Sequence of Operation Flow Chart

1. Icemaker Flow Chart

AM-50BAJ Series Icemaker Sequence Flow Chart

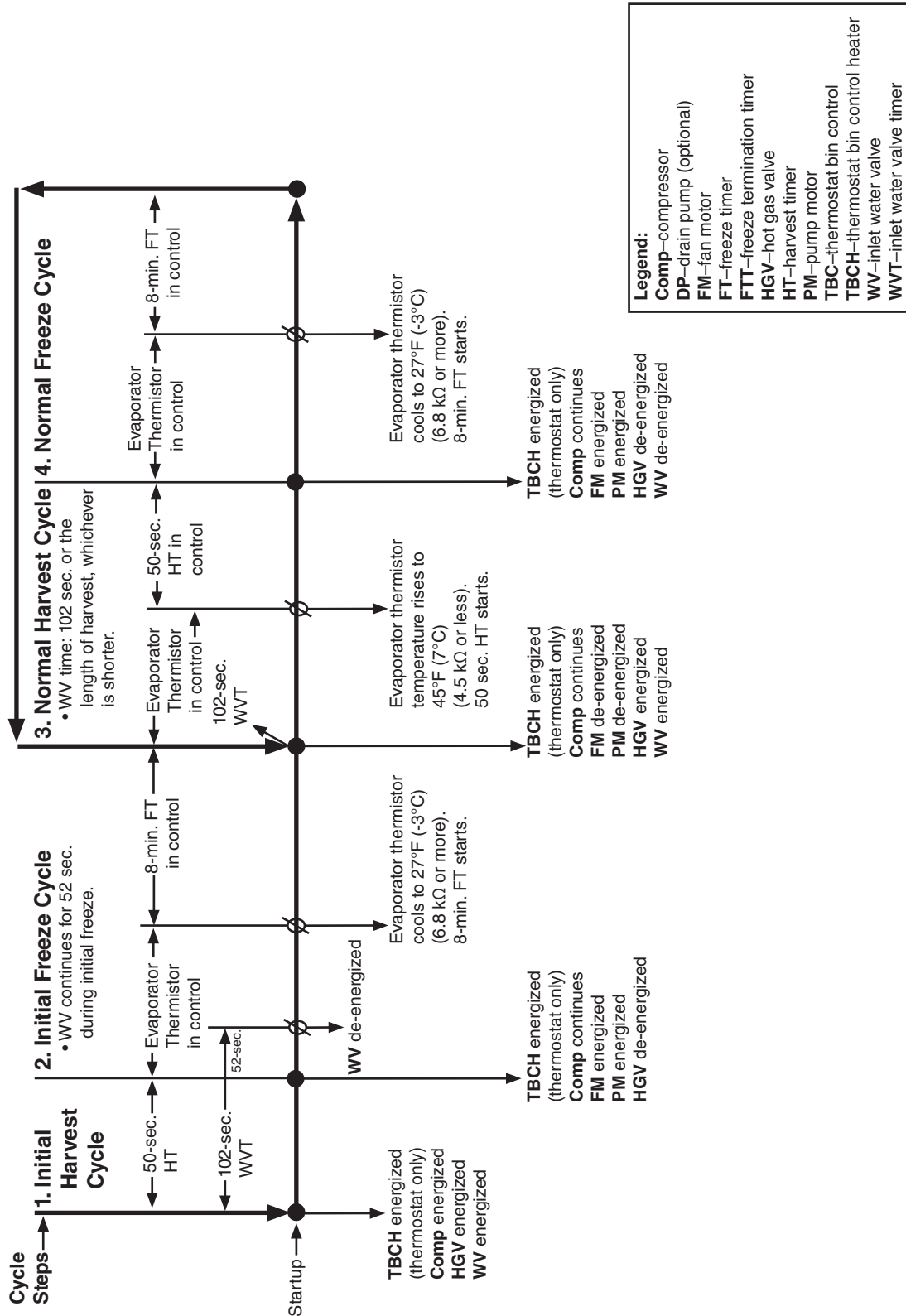

2. Bin Control Shutdown Flow Chart

AM-50BAJ Series Thermostat Bin Control Shutdown Sequence Flow Chart

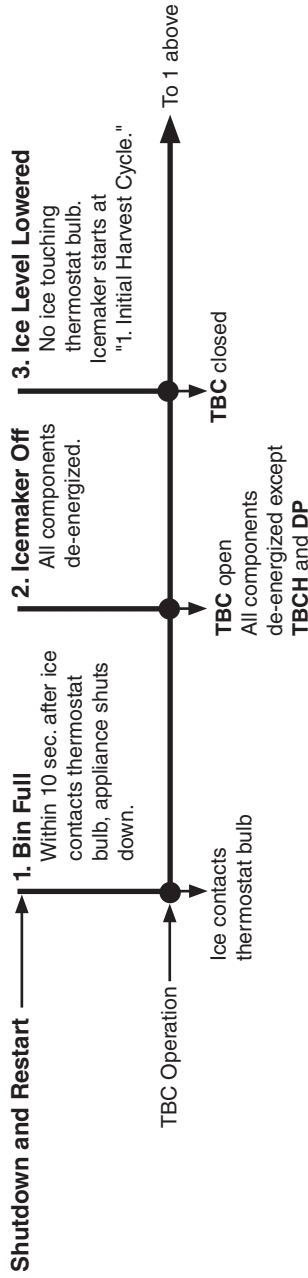

AM-50BAJ Series Thermistor Bin Control Shutdown Sequence Flow Chart

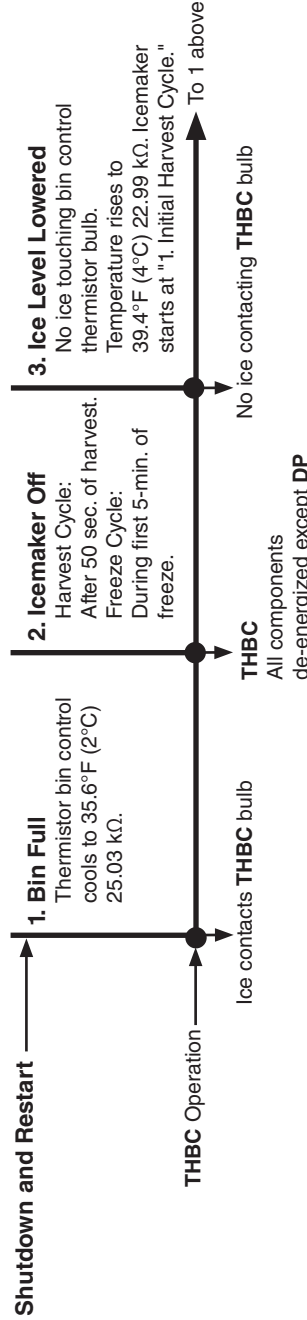

Legend:
Comp—compressor
DP—drain pump (optional)
FM—fan motor
FT—freeze timer
FTT—freeze termination timer
HGV—hot gas valve
HT—harvest timer
PM—pump motor
TBC—thermostat bin control
TBCH—bin control heater
THBC—thermistor bin control
WV—inlet water valve
WVT—inlet water valve timer

Components Energized when the Control Switch is in the "WASH" Position

The "WASH" position on the control switch is used when cleaning and sanitizing the icemaker. When in the "WASH" position, power is supplied to the pump motor and fan motor. The cleaner and sanitizer flow over the evaporator plate assembly.

B. Service Diagnosis

1. Thermostat Bin Control

WARNING

- The appliance should be diagnosed and repaired only by qualified service personnel to reduce the risk of death, electric shock, serious injury, or fire.
- Risk of electric shock. Use extreme caution and exercise safe electrical practices.
- Risk of electric shock. Control switch in "OFF" position does not de-energize all loads (optional drain pump).
- Moving parts (e.g., fan blade) can crush and cut. Keep hands clear.
- **CHOKING HAZARD:** Ensure all components, fasteners, and thumbscrews are securely in place after the appliance is serviced. Make sure that none have fallen into the ice storage bin.
- Make sure all food zones in the appliance are clean after service.

The diagnostic procedure is a sequence check that allows you to diagnose the electrical system and components. Before proceeding, check for correct installation, proper voltage per nameplate, and adequate water supply.

Note: • When checking high-voltage (115VAC), always choose a white (W) neutral wire to establish a good neutral connection.

- When checking low-voltage (24VAC) (auxiliary code C-1 and later), always choose a light blue (LBU) neutral wire to establish a good neutral connection.
- When checking component voltage from CB, pull CB connectors out slightly to allow room for multimeter test leads contact.
- Thermostat Bin Control: Bin Control Heater energizes at startup and continues until the control switch is turned off or power is disconnected.
- Optional drain pump ([HS-5061](#)) has 115VAC power supply as soon as the appliance is plugged into the electrical outlet.

- 1) Access the control box and move the control switch to the "OFF" position.
- 2) Clear any ice from the thermostat bin control or the thermistor bin control.

Operation Diagnosis:

- 3) **Power On/Initial Harvest Cycle – LED 1 is flashing and LED 3 is on.** Move the control switch to the "ICE" position. CB LEDs 1 (green), 3 (green), and 4 (orange) turn on briefly then turn off. Then CB green LED 1 starts flashing, CB green LED 3 turns on and Comp, HGV, and WV energize. Initial harvest cycle starts. 50-sec. HT and 102-sec. WVT start.

Note: 24VAC to CB is confirmed with a flashing LED 1.

- a) **Power On Diagnosis:** Confirm CB green LED 1 is flashing. If not, confirm appliance is plugged into electrical outlet. If optional drain pump HS-5061 is installed, confirm the water level in the drain pump reservoir is not high enough to close the drain pump safety switch. When the water level lowers enough to open the drain pump upper float switch, power is restored to the icemaker. The pump motor remains energized as long as the drain pump lower float switch is closed. If optional drain pump is not installed, check that jumper connection is good. Next, check for 115VAC at control switch #2 (BR) to neutral (W) then at control switch #1 (BR) ((BK) wire auxiliary code L-0(F) and later) to neutral (W). If 115VAC is present at #2 (BR) to neutral (W) and not at #1 (BR) ((BK) wire auxiliary code L-0(F) and later) to neutral (W), replace control switch.
- Thermostat - Bin Control:** Check thermostat continuity. If open, warm TBC bulb with hand. See "II.D. Bin Control Check." If TBC does not close, replace TBC. If TBC is closed and LED 1 is not flashing, check for 115VAC primary voltage and 24VAC secondary voltage at CT. If 115VAC is present and 24VAC is not, replace CT. If 24VAC is present, check for 24VAC at CB B (R) to CB W (LBU). If 24VAC is not present, check low-voltage wiring. If 24VAC is present and CB green LED 1 is not on and flashing, replace CB.
- b) **TBCH Diagnosis: Thermostat Bin Control Heater:** If TBCH does not energize, check TBCH continuity. If open, replace TBCH.
- c) **Comp Diagnosis:** If Comp does not energize, check PTC relay continuity. If open, replace PTC. If closed, check Comp external protector and motor winding continuity. Replace as needed.
- d) **HGV Diagnosis:** If Comp is energized and evaporator is not warming, check that HGV energizes and opens. If not, check for 115VAC at CB C1 (BR) to neutral (W) and at CB B1 (P) to neutral (W). If 115VAC is present at CB C1 (BR) to neutral (W) and not at CB B1 (P) to neutral (W), replace CB. If 115VAC is not present at CB C1 (BR) to neutral (W), check wiring connections from BC. If 115VAC is present, check HGV coil continuity. Replace as needed.
- e) **WV Diagnosis:** Confirm LED 3 is on. If not, replace CB. If LED 3 is on, check that water enters the water tank. If not, check that the water supply line shut-off valve is open and screens or external filters are clear. Check for 115VAC at CB C2 (BR) to neutral (W) and CB A2 (O) to neutral (W). If 115VAC is not present at CB C2 (BR) to neutral (W), check wiring from BC. If 115VAC is present at CB C2 (BR) to neutral (W) and not at CB A2 (O) to neutral (W), replace CB. If 115VAC is present and WV does not energize, check WV coil continuity. If open, replace WV.
- f) **Initial Harvest Cycle Termination Diagnosis:** 50-sec. HT terminates and freeze cycle starts. If not, replace CB.

- 4) **Initial Freeze Cycle – LED 1 is flashing and LEDs 3 and 2 are on.** Comp and 102-sec. WVT (WV continues another 52 sec. in freeze cycle) continue. FM and PM energize. HGV de-energizes. When 102-sec. WVT terminates, LED 3 turns off and WV de-energizes. CB monitors the cooling of the evaporator via the thermistor located on the evaporator for freeze termination. When the evaporator thermistor reaches 27°F (-3°C), CB reads 6.8 kΩ or higher from the evaporator thermistor and starts the 8-min. FT. Evaporator temperature of 27°F (-3°C) or lower (6.8 kΩ or higher) must be maintained through-out the 8-min. FT.
- a) **Comp Diagnosis:** If Comp de-energizes, check PTC relay continuity. If open, replace PTC. If closed, check Comp external protector and motor winding continuity. Replace as needed. If Comp is energized but evaporator is not cooling, check for an inefficient Comp. See "VIII.B. Performance Data."
 - b) **FM Diagnosis:** If FM does not energize, check for 115VAC at CB C1 (BR) to neutral (W) and at CB A1 (DBU) to neutral (W). If 115VAC is present at CB C1 (BR) to neutral (W) and not at CB A1 (DBU) to neutral (W), replace CB. If 115VAC is present at CB A1 (DBU) to neutral (W), check FM winding continuity, fan blade for binding.
 - c) **PM Diagnosis:** If PM does not energize, check for 115VAC at CB C1 (BR) to neutral (W) and at CB A1 (DBU) to neutral (W). If 115VAC is present at CB C1 (BR) to neutral (W) and not at CB A1 (DBU) to neutral (W), replace CB. If 115VAC is present at CB A1 (DBU) to neutral (W), check PM fuse (J-1 and later), motor winding continuity, impeller for binding, and PM capacitor (N-0 and earlier).
 - d) **HGV and WV Diagnosis:** Confirm HGV and WV de-energize. If HGV is energized, check for 115VAC at CB B1 (P) to neutral (W). If 115VAC is present after PM energizes, replace CB. If 115VAC is not present and HGV is bypassing, replace HGV. If LED 3 does not turn off and WV does not de-energize 52 sec. after freeze cycle starts, check for 115VAC at CB A2 (O) to neutral (W). If 115VAC is present 52 sec. or later after PM energizes, replace CB. If 115VAC is not present and WV is leaking by, replace WV.
 - e) **Initial Freeze Cycle Termination Diagnosis:** Freeze termination is temperature/time terminated. Once evaporator temperature reaches 27°F (-3°C) (6.8 KΩ or higher) 8-min. FT starts. Evaporator temperature must stay below 27°F (-3°C) (6.8 KΩ or higher) through-out the 8-min. FT. Once the 8-min. FT terminates, CB checks the evaporator thermistor for 6.8 KΩ or higher. If 6.8 KΩ or higher value is met at the end of the 8-min. FT, harvest cycle starts. FM and PM de-energize and HGV and WV energize. If not, check that evaporator thermistor is properly mounted. Next, remove the evaporator thermistor connections to CB and check the thermistor KΩ. See "II.E. Evaporator Thermistor Check." If evaporator temperature is below 27°F (-3°C) (6.8 KΩ or higher) for more than 8 min. and freeze does not terminate, replace CB.

5) **Normal Harvest Cycle – LED 1 is flashing and LED 3 is on.** Comp continues. HGV and WV energize. FM and PM de-energize. 102-sec. WV timer starts. CB monitors the warming of the evaporator via the thermistor located on the evaporator. When the thermistor reaches 47°F (7°C), CB reads 4.5 kΩ from the thermistor and turns harvest termination over to the 50-sec. HT. WV is energized during harvest for a maximum of 102 sec. or the length of harvest, whichever is shorter.

Note: Appliance continues to cycle until TBC is satisfied or power is turned off.

The appliance always restarts at the initial harvest cycle.

- a) **Comp Diagnosis:** Check that evaporator is warming. If not, confirm Comp is energized. If not, check for 115VAC at PTC and check PTC relay continuity. If open, replace PTC. If closed, check Comp external protector and motor winding continuity. Replace as needed.
- b) **HGV Diagnosis:** If Comp is energized and evaporator is not warming, check that HGV energizes and opens. If not, check for 115VAC at CB C1 (BR) to neutral (W) and CB B1 (P) to neutral (W). If 115VAC is present at CB C1 (BR) to neutral (W) and not at CB B1 (P) to neutral (W), replace CB. If 115VAC is not present at CB C1 (BR) to neutral (W), check wiring connections from BC. If 115VAC is present, check HGV coil continuity. Replace as needed.
- c) **WV Diagnosis:** Confirm LED 3 is on. If not, replace CB. If LED 3 is on, check that water enters the water tank. If not, check that the water supply line shut-off valve is open and screens or external filters are clear. Check for 115VAC at CB C2 (BR) to neutral (W) and CB A2 (O) to neutral (W). If 115VAC is not present at CB C2 (BR) to neutral (W), check wiring from BC. If 115VAC is present at CB C2 (BR) to neutral (W) and not at CB A2 (O) to neutral (W), replace CB. If 115VAC is present and WV does not energize, check WV coil continuity. If open, replace WV.
- d) **FM and PM Diagnosis:** If FM and PM continue after LED 2 turns off, replace CB.
- e) **Normal Harvest Cycle Termination Diagnosis:** For an evaporator thermistor check, see "II.D. Evaporator Thermistor Check." If evaporator is warming, thermistor reading is correct, and harvest does not terminate, replace CB.

- 6) **Normal Freeze Cycle – LED 1 is flashing and LED 2 is on.** Comp continues. FM and PM energize. HGV and WV de-energize. CB monitors the cooling of the evaporator via the thermistor located on the evaporator for freeze termination. When the thermistor reaches 27°F (-3°C), CB reads 6.8 kΩ from the thermistor and starts the 8-min. FT. 27°F (-3°C) or lower (6.8 kΩ or higher) must be maintained the entire 8 min.
- a) **Comp Diagnosis:** If Comp de-energizes, check PTC relay continuity. If open, replace PTC. If closed, check Comp external protector and motor winding continuity. Replace as needed. If Comp is energized but evaporator is not cooling, check for an inefficient Comp. See "VIII.A. Specification and Performance Data."
 - b) **FM Diagnosis:** If FM does not energize, check for 115VAC at CB C1 (BR) to neutral (W) and at CB A1 (DBU) to neutral (W). If 115VAC is present at CB C1 (BR) to neutral (W) and not at CB A1 (DBU) to neutral (W), replace CB. If 115VAC is present at CB A1 (DBU) to neutral (W), check FM winding continuity, fan blade for binding.
 - c) **PM Diagnosis:** If PM does not energize, check for 115VAC at CB C1 (BR) to neutral (W) and at CB A1 (DBU) to neutral (W). If 115VAC is present at CB C1 (BR) to neutral (W) and not at CB A1 (DBU) to neutral (W), replace CB. If 115VAC is present at CB A1 (DBU) to neutral (W), check PM fuse (J-1 and later), motor winding continuity, impeller for binding, and PM capacitor (N-0 and earlier).
 - d) **HGV and WV Diagnosis:** Confirm HGV and WV de-energize. If HGV is energized, check for 115VAC at CB B1 (P) to neutral (W). If 115VAC is present after PM energizes, replace CB. If 115VAC is not present and HGV is bypassing, replace HGV. If LED 3 is on after LED 2 turns on, replace CB. When LED 3 turns off, make sure WV is not leaking by. If WV is leaking by, replace WV.
 - e) **Normal Freeze Cycle Termination Diagnosis:** Freeze termination is temperature/time terminated. Once evaporator temperature reaches 27°F (-3°C) (6.8 KΩ or higher) 8-min. FT starts. Evaporator temperature must stay below 27°F (-3°C) (6.8 KΩ or higher) through-out the 8-min. FT. Once the 8-min. FT terminates, CB checks the evaporator thermistor for 6.8 KΩ or higher. If 6.8 KΩ or higher value is met at the end of the 8-min. FT, harvest cycle starts. FM and PM de-energize and HGV and WV energize. If not, check that evaporator thermistor is properly mounted. Next, remove the evaporator thermistor connections to CB and check the thermistor KΩ. See "II.E. Evaporator Thermistor Check." If evaporator temperature is below 27°F (-3°C) (6.8 KΩ or higher) for more than 8 min. and freeze does not terminate, replace CB.
- 7) **Shutdown - Thermostat Bin Control:** When the appliance is running, hold ice in contact with the TBC bulb. TBC switch opens within 10 sec., shutting down the appliance. TBC is factory set, and generally no adjustment is required. However, adjustment may be needed in some conditions, particularly at higher altitude locations.

Legend: **CB**—control board; **Comp**—compressor; **FM**—fan motor; **FT**—freeze timer; **FTT**—freeze termination timer; **HGV**—hot gas valve; **HT**—harvest timer; **PM**—pump motor; **TBC**—thermostat bin control; **TBCH**—thermostat bin control heater; **WV**—inlet water valve; **WVT**—inlet water valve timer

2. Thermistor Bin Control

WARNING

- The appliance should be diagnosed and repaired only by qualified service personnel to reduce the risk of death, electric shock, serious injury, or fire.
- Risk of electric shock. Use extreme caution and exercise safe electrical practices.
- Risk of electric shock. Control switch in "OFF" position does not de-energize all loads (optional drain pump).
- Moving parts (e.g., fan blade) can crush and cut. Keep hands clear.
- **CHOKING HAZARD:** Ensure all components, fasteners, and thumbscrews are securely in place after the appliance is serviced. Make sure that none have fallen into the ice storage bin.
- Make sure all food zones in the appliance are clean after service.

The diagnostic procedure is a sequence check that allows you to diagnose the electrical system and components. Before proceeding, check for correct installation, proper voltage per nameplate, and adequate water supply.

Note: • When checking high-voltage (115VAC), always choose a white (W) neutral wire to establish a good neutral connection.

- When checking component voltage from MCB or THCB, pull connectors out slightly to allow room for multimeter test leads contact.
- Optional drain pump ([HS-5061](#)) has 115VAC power supply as soon as the appliance is plugged into the electrical outlet.

- 1) Access the control box and move the control switch to the "OFF" position.
- 2) Clear any ice from the thermistor bin control.

Operation Diagnosis:

- 3) **Power On/Initial Harvest Cycle.** Move the control switch to the "ICE" position. THCB green LED 1 "POWER" turns on. If THCB is at or above 39.2°F (4°C), THCB green LED 2 turns on and THCB X1 relay energizes. 115VAC supplied to CT and MCB. MCB LEDs 1 (green), 3 (green), and 4 (orange) turn on briefly then turn off. Then green LED 1 starts flashing, green LED 3 turns on and Comp, HGV, and WV energize. Initial harvest cycle starts. 50-sec. HT and 102-sec. WVT start.

Note: 24VAC to CB is confirmed with a flashing LED 1.

- a) **Power On Diagnosis:** Confirm THCB green LED 1 "POWER" and green LED 2 "RELAY" are on and MCB green LED 1 (power) is flashing. If not, confirm appliance is plugged into electrical outlet. If optional drain pump HS-5061 is installed, confirm the water level in the drain pump reservoir is not high enough to close the drain pump safety switch. When the water level lowers enough to open the drain pump upper float switch, power is restored to the icemaker. The pump motor remains energized as long as the drain pump lower float switch is closed. If optional drain pump is not installed, check that jumper connection is good.

Control Switch: Check for 115VAC at control switch #2 (BR) to neutral (W) then at control switch #1 (BR) or (BK) (auxiliary code L-0(F) and later) to neutral (W). If 115VAC is present at #2 (BR) or (BK) to neutral (W) and not at #1 (BR) or (BK) (auxiliary code L-0(F) and later) to neutral (W), replace control switch.

Bin Control Thermistor and Thermistor Control Board: If 115VAC is present at control switch #1 (BR) or (BK) (auxiliary code L-0(F) and later) to neutral (W) and THCB green "POWER" LED 1 is not on, check wiring from control switch to THCB. If wiring is good, replace THCB. If THCB green "POWER" LED 1 is on and THCB green "RELAY" LED 2 is not on, remove THCB wires from THCB K2 connectors and check THCB continuity. See "C.2. Bin Control Thermistor - Auxiliary Code N-2 and Later." Replace as needed. If THCB is good, reconnect THCB wires to THCB K2. Next, check that MCB LED 1 is flashing. If MCB LED 1 is not flashing, check THCB X1 (BK) to neutral (W) for 115VAC. If 115VAC is present, check for 115VAC at THCB X1 (BR) to neutral (W). If 115VAC is present at THCB X1 (BK) and not at THCB X1 (BR), check for 115VAC at THCB K1 1 (DBU). If 115VAC is present at THCB K1 1 (DBU) and 115VAC is not present at THCB X1 (BR) (THCB LED 2 not on), replace THCB. If 115VAC is present at THCB X1 (BR) not present at THCB K1 1 (DBU), see "Control Transformer and Main Control Board" below.

Control Transformer: If 115VAC is present on THCB X1 (BR) and MCB LED 1 is not flashing, check for 24VAC secondary voltage at CT red (R) wire to CT light blue (LBU) wire. If 24VAC is not present, check low-voltage wiring. If low-voltage wiring is good, disconnect power and check CT windings. If open, replace CT.

Main Control Board: If 24VAC is present at MCB and MCB green LED 1 is not flashing, replace MCB. If MCB LED 1 is flashing and THCB LED 2 is not on, check MCB A1 (DBU) to neutral (W). If 115VAC is not present, replace MCB. If 115VAC is present at MCB A1 (DBU), check K1 1 (DBU). If 115VAC is present and LED 2 is not on, replace THCB.

- b) **Comp Diagnosis:** With MCB green LED 1 flashing, if Comp does not energize, check for 115VAC at control switch #4 (BR) to neutral (W) then at control switch #5 (R) to neutral (W). If 115VAC is present at #4 (BR) to neutral (W) and not at #5 (R) to neutral (W), replace control switch. If 115VAC is present at #5 (R) to neutral (W), check PTC relay continuity. If open, replace PTC. If closed, check Comp external protector and motor winding continuity. Replace as needed.
- c) **HGV Diagnosis:** If Comp is energized and evaporator is not warming, check that HGV energizes and opens. If not, check for 115VAC at MCB C1 (BR) to neutral (W) and then at MCB B1 (P) to neutral (W). If 115VAC is not present at MCB C1 (BR) to neutral (W), check wiring connections from THCB. If 115VAC is present at MCB C1 (BR) to neutral (W) and not at MCB B1 (P) to neutral (W), replace MCB. If 115VAC is present at MCB B1 (P) wire to neutral (W), check HGV coil continuity. Replace as needed.
- d) **WV (LED 3) Diagnosis:** Confirm MCB green LED 3 is on. If not, replace CB. If MCB green LED 3 is on, check that water enters the water tank. If not, check that the water supply line shut-off valve is open and screens or external filters are clear. Check for 115VAC at MCB C2 (BR) to neutral (W) and MCB A2 (O) wire to neutral (W) wire. If 115VAC is not present at MCB C2 (BR) to neutral (W), check wiring from THCB. If 115VAC is present at MCB C2 (BR) to neutral (W) wire and not at CB A2 (O) to neutral (W), replace MCB. If 115VAC is present and WV does not energize, check WV coil continuity. If open, replace WV.
- e) **Initial Harvest Cycle Termination Diagnosis:** 50-sec. HT terminates and freeze cycle starts. HGV de-energizes. If not, replace MCB. Comp continues. WV continues an additional 52 sec. into initial freeze cycle.
- 4) **Initial Freeze Cycle – MCB LED 1 and LED 3 continue and LED 2 turns on.** Comp and 102-sec. WVT (WV continues another 52 sec. in freeze cycle) continue. FM and PM energize. HGV de-energizes. When 102-sec. WVT terminates, MCB LED 3 turns off and WV de-energizes. MCB monitors the cooling of the evaporator via the thermistor located on the evaporator for freeze termination. When the evaporator thermistor reaches 27°F (-3°C), MCB reads 6.8 kΩ or higher from the evaporator thermistor and starts the 8-min. FT. Evaporator temperature of 27°F (-3°C) or lower (6.8 kΩ or higher) must be maintained through-out the 8-min. FT.
- a) **Comp Diagnosis:** If Comp de-energizes, check PTC relay continuity. If open, replace PTC. If closed, check Comp external protector and motor winding continuity. Replace as needed. If Comp is energized but evaporator is not cooling, check for an inefficient Comp. See "VIII.B. Performance Data."
- b) **FM Diagnosis:** If FM does not energize, check for 115VAC at MCB C1 (BR) to neutral (W) and then at CB A1 (DBU) to neutral (W). If 115VAC is present at MCB C1 (BR) to neutral (W) and not at MCB A1 (DBU) to neutral (W), replace MCB. If 115VAC is present at MCB A1 (DBU) to neutral (W), check FM winding continuity and fan blade for binding.

- c) **PM Diagnosis:** If PM does not energize, check for 115VAC at MCB C1 (BR) to neutral (W) and then at CB A1 (DBU) to neutral (W). If 115VAC is present at MCB C1 (BR) to neutral (W) and not at MCB A1(DBU) to neutral (W), replace MCB. If 115VAC is present at MCB A1 (DBU) to neutral (W), check 0.375A PM fuse, replace as needed. If PM fuse is good, check PM capacitor and motor windings, replace as needed.
- d) **HGV and WV Diagnosis:** Confirm HGV and WV de-energize. If HGV is energized, check for 115VAC at MCB B1 (P) to neutral (W). If 115VAC is present after PM energizes, replace MCB. If 115VAC is not present and HGV is bypassing, replace HGV. If MCB green LED 3 does not turn off and WV does not de-energize 52 sec. after initial freeze cycle starts, check for 115VAC at MCB A2 (O) to neutral (W). If 115VAC is present 52 sec. or later after PM energizes, replace MCB. If 115VAC is not present and WV is leaking by, replace WV.
- e) **Initial Freeze Cycle Termination Diagnosis:** Freeze termination is temperature/time terminated. Once the evaporator temperature reaches 27°F (-3°C) (6.8 KΩ or higher) 8-min. FT starts. Evaporator temperature must stay below 27°F (-3°C) (6.8 KΩ or higher) through-out the 8-min. FT. Once the 8-min. FT terminates, MCB checks evaporator thermistor for 6.8 KΩ or higher. If 6.8 KΩ or higher value is met at the end of the 8-min. FT, harvest cycle starts. FM and PM de-energize and HGV and WV energize. If not, check that evaporator thermistor is properly mounted. Next, remove the evaporator thermistor connections to MCB and check the thermistor KΩ. See "II.E. Evaporator Thermistor Check." If evaporator temperature is below 27°F (-3°C) (6.8 KΩ or higher) for more than 8 min. and freeze does not terminate, replace MCB.
- 5) **Normal Harvest Cycle – LED 1 is flashing, Green LED 3 is on, and Green LED 2 turns off.** Comp continues. HGV and WV energize. FM and PM de-energize. 50-sec. HT and 102-sec. WV timer starts. MCB monitors the warming of the evaporator via the evaporator thermistor. When the evaporator thermistor reaches 47°F (7°C), MCB reads 4.5 kΩ from the thermistor and starts 50-sec. HT. WV is energized during harvest for a maximum of 102 sec. or the length of harvest, whichever is shorter.
Note: Appliance continues to cycle until THBC is satisfied or power is turned off.
The appliance always restarts at the initial harvest cycle.
- a) **Comp Diagnosis:** Check that evaporator is warming. If not, confirm Comp is energized. If not, check for 115VAC at PTC and check PTC relay continuity. If open, replace PTC. If closed, check Comp external protector and motor winding continuity. Replace as needed.
- b) **HGV Diagnosis:** If Comp is energized and evaporator is not warming, check that HGV energizes and opens. If not, check for 115VAC at MCB C1 (BR) to neutral (W) and CB B1 (P) to neutral (W). If 115VAC is present at CB C1 (BR) to neutral (W) and not at MCB B1 (P) to neutral (W), replace MCB. If 115VAC is not present at MCB C1 (BR) to neutral (W), check wiring connections from THCB. If 115VAC is present, check HGV coil continuity. Replace as needed.

- c) **WV Diagnosis:** Confirm MCB green LED 3 is on. If not, replace MCB. If MCB green LED 3 is on, check that water enters the water tank. If not, check that the water supply line shut-off valve is open and screens or external filters are clear. Check for 115VAC at MCB C2 (BR) to neutral (W) and MCB A2 (O) to neutral (W). If 115VAC is not present at MCB C2 (BR) to neutral (W), check wiring from THCB. If 115VAC is present at MCB C2 (BR) to neutral (W) and not at MCB A2 (O) to neutral (W), replace MCB. If 115VAC is present and WV does not energize, check WV coil continuity. If open, replace WV.
- d) **FM and PM Diagnosis:** If FM and PM continue after green LED 2 turns off, replace MCB.
- e) **Normal Harvest Cycle Termination Diagnosis:** Normal harvest termination is a temperature/time termination. Evaporator temperature reaches 45°F (7°C) (4.5 KΩ or less) 50-sec. HT starts. For evaporator thermistor check, see "II.D. Evaporator Thermistor Check." If evaporator is warming, thermistor reading is within spec, and harvest does not terminate, replace MCB.
- 6) **Normal Freeze Cycle – LED 1 is flashing and LED 2 is on.** Comp continues. FM and PM energize. HGV and WV de-energize. MCB monitors the cooling of the evaporator via the thermistor located on the evaporator for freeze termination. When the thermistor reaches 27°F (-3°C), MCB reads 6.8 kΩ or higher from the thermistor and starts the 8-min. FT. 27°F (-3°C) or lower (6.8 kΩ or higher) must be maintained the entire 8 min.
- a) **Comp Diagnosis:** If Comp de-energizes, check PTC relay continuity. If open, replace PTC. If closed, check Comp external protector and motor winding continuity. Replace as needed. If Comp is energized but evaporator is not cooling, check for an inefficient Comp. See "VIII.A. Specification and Performance Data."
- b) **FM Diagnosis:** If FM does not energize, check for 115VAC at MCB C1 (BR) to neutral (W) and at MCB A1 (DBU) to neutral (W). If 115VAC is present at MCB C1 (BR) to neutral (W) and not at MCB A1 (DBU) to neutral (W), replace MCB. If 115VAC is present at MCB A1 (DBU) to neutral (W), check FM winding continuity, fan blade for binding.
- c) **PM Diagnosis:** If PM does not energize, check for 115VAC at CB C1 (BR) to neutral (W) and at CB A1 (DBU) to neutral (W). If 115VAC is present at MCB C1 (BR) to neutral (W) and not at MCB A1 (DBU) to neutral (W), replace MCB. If 115VAC is present at MCB A1 (DBU) to neutral (W), check PM fuse. Replace as needed. If PM fuse is good, check PM motor winding continuity, impeller for binding, and PM capacitor (N-0 and earlier).
- d) **HGV and WV Diagnosis:** Confirm HGV and WV de-energize. If HGV is energized, check for 115VAC at MCB B1 (P) to neutral (W). If 115VAC is present after PM energizes, replace MCB. If 115VAC is not present and HGV is bypassing, replace HGV. If LED 3 is on after LED 2 turns on, replace MCB. When LED 3 turns off, make sure WV is not leaking by. If WV is leaking by, replace WV.

e) **Normal Freeze Cycle Termination Diagnosis:** Freeze termination is temperature/time terminated. Once the evaporator temperature reaches 27°F (-3°C) (6.8 KΩ or higher) 8-min. FT starts. Evaporator temperature must stay below 27°F (-3°C) (6.8 KΩ or higher) through-out the 8-min. FT. Once the 8-min. FT terminates, MCB checks evaporator thermistor for 6.8 KΩ or higher. If 6.8 KΩ or higher value is met at the end of the 8-min. FT, harvest cycle starts. FM and PM de-energize and HGV and WV energize. If not, check that evaporator thermistor is properly mounted. Next, remove the evaporator thermistor connections to MCB and check the thermistor KΩ. See "II.E. Evaporator Thermistor Check." If evaporator temperature is below 27°F (-3°C) (6.8 KΩ or higher) for more than 8 min. and freeze does not terminate, replace MCB.

7) **Shutdown - Thermistor Bin Control:** When the appliance is running, hold ice in contact with the thermistor bulb. THCB X1 relay switch opens within 30 to 60 sec., shutting down the appliance. No adjustment available. If THCB X1 relay switch does not shutdown icemaker, check THBC KΩ reading. See "II.C.2. Thermistor Bin Control Check." If the bin control thermistor is good and icemaker does not shutdown, replace THCB.

Legend: **Comp**—compressor; **FM**—fan motor; **FT**—freeze timer; **FTT**—freeze termination timer; **HGV**—hot gas valve; **HT**—harvest timer; **MCB**—main control board; **PM**—pump motor; **THBC**—thermistor bin control; **THCB**—thermistor control board; **WV**—inlet water valve; **WVT**—inlet water valve timer

C. Bin Control Check

1. Thermostat Bin Control - Auxiliary Code N-1 and Earlier

TBC shuts down the icemaker within 10 sec. when ice contacts the thermostat bulb, regardless of the cycle at activation.

NOTICE

When the ambient temperature is below 45°F (7°C), TBC opens and shuts down the appliance even if the ice storage bin is empty. When TBC is set in the prohibited range, the appliance operates continuously even if the ice storage bin is filled with ice. Setting in the prohibited range may result in severe damage to the appliance.

The TBC is factory set, and generally no adjustment is required. However, adjustment may be needed in some conditions, particularly at higher altitude locations.

For TBC check, follow the steps below.

- 1) Move the control switch to the "OFF" position.
- 2) Unplug the appliance.
- 3) Remove the control box cover. Loosen the control box from the base and slide it out for easy access. Next, clear any ice away from TBC bulb.
- 4) Disconnect the TBC wires from TBC switch.
- 5) Hold your hand around the bulb to warm it up.
- 6) Check for continuity across TBC switch. If closed, continue to step 7. If open, adjust or replace TBC.
- 7) With the multimeter test leads still in place, hold ice in contact with TBC bulb. Within 10 sec., TBC switch should open. If it remains closed, adjust or replace TBC.
- 8) Confirm the TBCH is energized and operating properly. Check TBCH continuity. Replace as needed.

Legend: **TBC**—thermostat bin control; **TBCH**; thermostat bin control heater

2. Thermistor Bin Control - Auxiliary Code N-2 and Later

To check the bin control thermistor, follow the steps below.

NOTICE

When the ambient temperature is below 45°F (7°C), the bin control thermistor may shut down the appliance even if the ice storage bin is empty.

For THBC check, follow the steps below.

- 1) Move the control switch to the "OFF" position.
- 2) Unplug the appliance.
- 3) Remove the front panel and control box cover. Loosen the control box from the base and slide it out for easy access. Next, clear any ice away from THBC.
- 4) Remove the bin control thermistor from mounting bracket.
- 5) Immerse the thermistor in a glass containing ice and water for 2 or 3 min.
- 6) Disconnect the THBC connector from the THCB and check the resistance between the thermistor leads. Normal range is 26.1 to 28.4 kΩ. If outside the normal range, replace THBC. If within the normal range, continue to the next step.
- 7) Replace the THBC in its correct position.
- 8) Reconnect the THBC connector to the THCB.
- 9) Replace the control box and control box cover in their correct positions.
- 10) Replace the front panel in its correct position.
- 11) Move the control switch to the "ICE" position.
- 12) Turn on the power supply.

Legend: **THBC**—thermistor bin control;
THCB—thermistor control board

TABLE 3 (ET-10K-1%-BETA 3435)					
°C	R/T	°C	R/T	°C	R/T
-16	55950	20	12090	56	3426
-15	53390	21	11630	57	3319
-14	50960	22	11200	58	3216
-13	48660	23	10780	59	3116
-12	46480	24	10380	60	3021
-11	44410	25	10000	61	2928
-10	42450	26	9632	62	2838
-9	40560	27	9281	63	2752
-8	38760	28	8944	64	2669
-7	37050	29	8622	65	2589
-6	35430	30	8313	66	2512
-5	33890	31	8015	67	2437
-4	32430	32	7729	68	2365
-3	31040	33	7455	69	2296
-2	29720	34	7192	70	2229
-1	28470	35	6941	71	2163
0	27280	36	6699	72	2100
1	26130	37	6468	73	2039
2	25030	38	6246	74	1980
3	23990	39	6033	75	1924
4	22990	40	5828	76	1869
5	22050	41	5630	77	1816
6	21150	42	5439	78	1765
7	20290	43	5256	79	1716
8	19480	44	5080	80	1668
9	18700	45	4912	81	1621
10	17960	46	4749	82	1577
11	17240	47	4594	83	1533
12	16550	48	4444	84	1491
13	15900	49	4300	85	1451
14	15280	50	4161	86	1411
15	14680	51	4026	87	1373
16	14120	52	3897	88	1336
17	13570	53	3772	89	1300
18	13060	54	3652	90	1266
19	12560	55	3537	95	1108

D. Evaporator Thermistor Check

To check the evaporator thermistor resistance, follow the steps below.

- 1) Move the control switch to the "OFF" position.
- 2) Unplug the appliance.
- 3) Remove the control box cover.
- 4) Remove the thermistor from the evaporator.
- 5) Immerse the evaporator thermistor sensor portion in a glass containing ice and water for 2 or 3 min.
- 6) Disconnect the evaporator thermistor connector from CB and check the resistance between the evaporator thermistor leads. Normal range is 5.5 to 6.5 k Ω . If outside the normal range, replace the evaporator thermistor. See "IV.B. Important Notes for Component Replacement." If within the normal range, continue to the next step.
- 7) Replace the evaporator thermistor in its correct position. See "IV.B. Important Notes for Component Replacement."
- 8) Reconnect the evaporator thermistor connector to CB.
- 9) Replace the control box cover in its correct position.
- 10) Plug the appliance back into the electrical outlet.
- 11) Move the control switch to the "ICE" position.

Legend: **CB**—control board;

E. Diagnostic Tables

1. No Ice Production

No Ice Production - Possible Cause	
1. Power Supply	a) Unplugged, off, blown fuse, or tripped breaker.
	b) Not within specifications.
2. Water Supply	a) Water supply off or improper water pressure.
	b) External water filters clogged.
3. Optional Drain Pump (HS-5061)	a) Safety switch open.
	b) Connector loose or disconnected.
	c) Clogged or kinked hose.
	d) Defective.
4. Control Switch	a) In "OFF" or "WASH" position.
	b) Bad contacts.
5a. Thermostat Bin Control See "II.C.1. Thermostat Bin Control Check"	a) Out of adjustment.
	b) Ambient temperature too cool.
	c) Thermostat Bulb out of bracket.
	d) Bin control heater defective.
	e) Defective.
5b. Thermistor Bin Control Aux. Code N-2 and Later See "II.C.2. Thermistor Bin Control Check"	a) Ambient temperature too cool.
	b) Thermistor out of bracket.
	c) Defective.
6. Thermistor Control Board Aux. Code N-2 and Later	a) Defective.
7. Control Transformer (115VAC/24VAC) (Auxiliary Code C-1 and Later)	a) Defective.
8. Main Control Board	a) Defective.
9. Compressor	a) External protector defective.
	b) PTC defective.
	c) Inefficient.
	d) Open windings.
10. Inlet Water Valve	a) Screen or orifice clogged.
	b) Coil winding open.
	c) Inlet water valve remains open longer than 52 sec. in initial freeze cycle or remains open in normal freeze cycle.
11. Hot Gas Valve	a) Closed in harvest cycle.
	b) Open in freeze cycle.
12. Evaporator Thermistor See "II.E. Evaporator Thermistor Check"	a) Loose, disconnected, or defective.
13. Pump Motor	a) Fuse blown.
	b) Motor winding open.
	c) Bearing worn out or locked rotor.
	d) Defective capacitor (if applicable).
14. Fan Motor	a) Motor winding open.
	b) Bearing worn out or locked rotor.

2. Freeze-Up

Defrost and clean the icemaker prior to diagnosing freeze-up. Fill out a freeze-up checklist. See the Hoshizaki America Technician's Pocket Guide or contact your local distributor for a copy of the freeze-up checklist.

Freeze-Up - Possible Cause	
Harvest Cycle	
1. Evaporator	a) Scaled up. b) Damaged.
2. Ice Chute	a) Out of position. b) Damaged.
3. Main Control Board See "III.B. Settings and Adjustments."	a) Harvest control set too short. Do not adjust. b) Freeze control set too long. c) Defective.
4a. Thermostat Bin Control See "II.C.1. Thermostat Bin Control Check"	a) Out of adjustment. b) Bin control heater defective. c) Defective.
4b. Thermistor - Bin Control Aux. Code N-2 and Later See "II.C.2. Thermistor Bin Control Check"	a) Defective.
5. Thermistor Control Board Aux. Code N-2 and Later	a) Defective.
6. Evaporator Thermistor See "II.D. Evaporator Thermistor Check"	a) Loose, disconnected, or defective.
7. Refrigerant Charge	a) Low.
8. Hot Gas Valve	a) Closed or restricted.
Freeze Cycle	
1. Evaporator	a) Scaled up. b) Damaged.
2. Spray Assembly	a) Nozzles dirty. b) Ice chute out of position.
Bin Control - Thermostat or Thermistor	
3a. Thermostat Bin Control See "II.C.1. Thermostat Bin Control Check"	a) Out of adjustment. b) Bin control heater defective. c) Defective.
3b. Thermistor Bin Control Aux. Code N-2 and Later See "II.C.2. Thermistor Bin Control Check"	a) Defective.
4. Thermistor Control Board Aux. Code N-2 and Later	a) Defective.
5. Main Control Board See "III.B. Settings and Adjustments."	a) Freeze control set incorrectly. b) Defective.

Freeze-Up - Possible Cause	
6. Evaporator Thermistor See "II.E. Evaporator Thermistor Check"	a) Defective.
7. Refrigerant Charge	a) Low.
8. Inlet Water Valve	a) Leaking by.
9. Pump Motor	a) RPM too slow.
	b) Impeller restricted or damaged.
	c) Defective.

3. Low Ice Production

Low Ice Production - Possible Cause	
Long Harvest Cycle	
1. Evaporator	a) Scaled up, dirty.
2. Ice Chute	a) Out of position.
	b) Damaged.
3. Refrigerant Charge	a) Low.
4. Main Control Board See "III.B. Settings and Adjustments."	a) Thermistor connection loose.
	b) Harvest control moved from factory setting.
	c) Defective.
5. Evaporator Thermistor See "II.E. Evaporator Thermistor Check"	a) Loose, disconnected, or defective.
6. Hot Gas Valve	a) Erratic or closed.
7. Inlet Water Valve	a) Screen or orifice clogged.
8. Compressor	a) Inefficient or off.
Long Freeze Cycle	
1. Evaporator	a) Scaled up, dirty.
2. Inlet Water Valve	a) Leaking by.
3. Hot Gas Valve	a) Erratic or open.
4. Condenser	a) Clogged.
5. Evaporator Thermistor See "II.E. Evaporator Thermistor Check"	a) Loose, disconnected, or defective.
6. Main Control Board See "III.B. Settings and Adjustments."	a) Freeze control set too long.
	b) Defective.
7. Refrigerant Charge	a) Low.
8. Compressor	a) Inefficient or off.
	a) RPM too slow.
	b) Impeller restricted or damaged.
9. Pump Motor	c) Defective.

III. Control Board

A. Main and Thermistor Control Boards

- Hoshizaki exclusive control boards are employed into the AM series appliances.
- All models are pretested and factory adjusted.

<i>NOTICE</i>
<ul style="list-style-type: none">• Fragile, handle very carefully.• The control boards contains integrated circuits, which are susceptible to failure due to static discharge. It is especially important to touch the metal part of the icemaker when handling or replacing the control board.• Do not touch the electronic devices on the control board or the back of the control board.• Do not change wiring and connections.• Do not short out power supply to test for voltage.• Always replace the whole control board assembly if it goes bad.

1. Main Control Board Layout

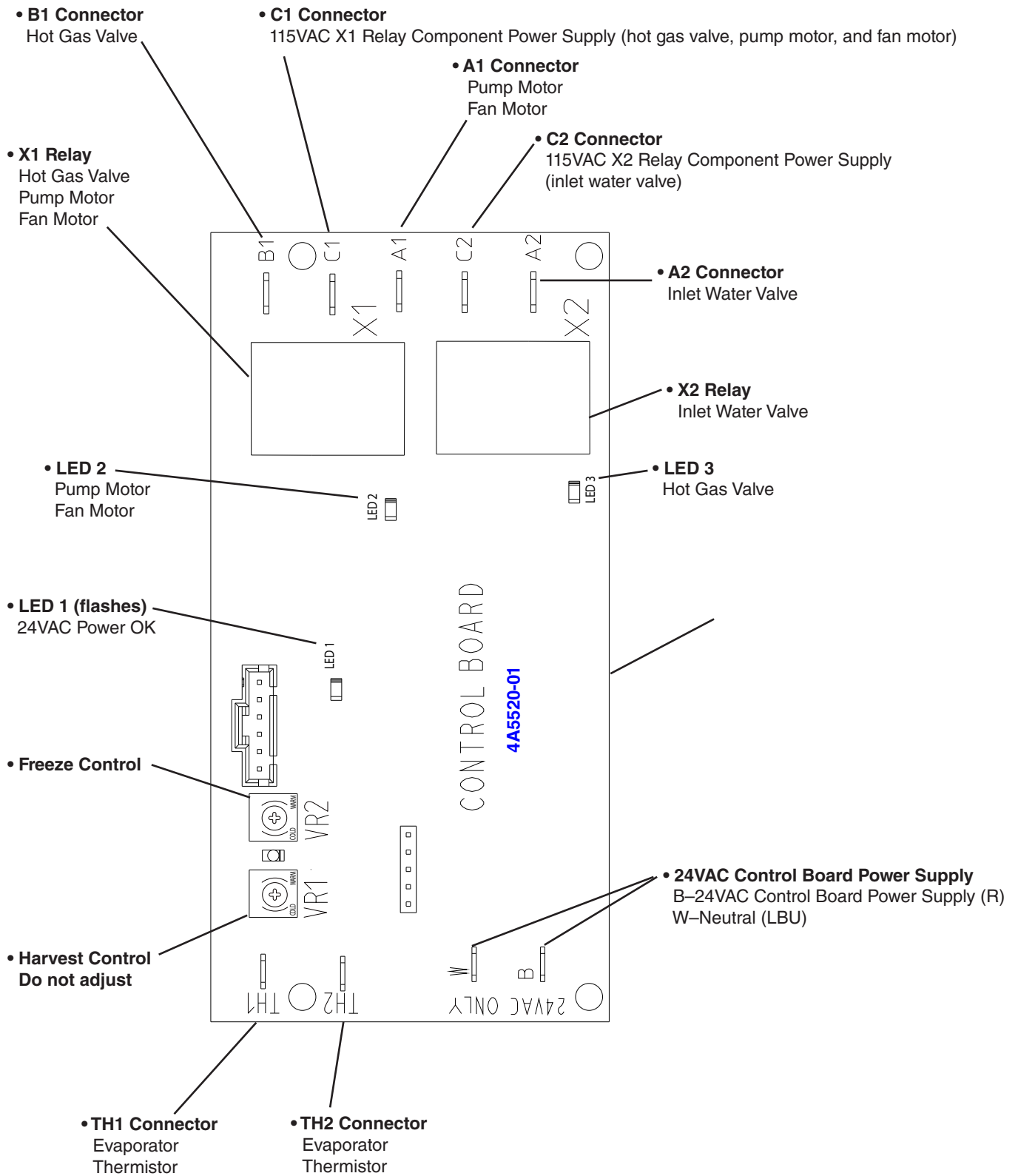

2. Thermistor Control Board Layout

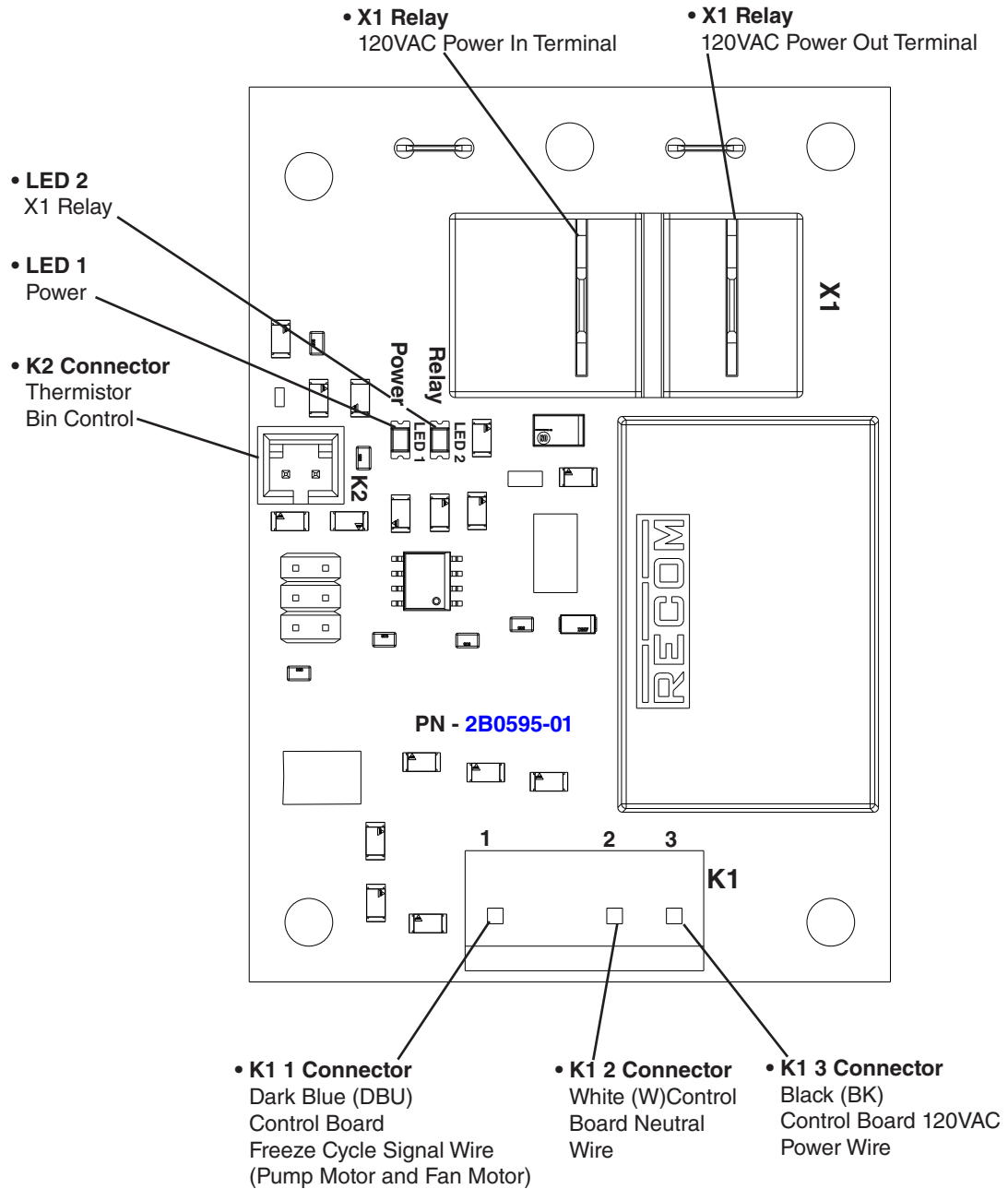

B. Main Control Board Settings and Adjustments

1) VR1 Harvest Control

VR1 harvest control is for adjustment of the harvest cycle completion temperature. Factory set, do not adjust.

NOTICE

Do not adjust VR1 harvest control. VR1 harvest control is factory set for proper operation. Adjustment outside of the factory default setting will result in freeze up and/or damage to the appliance.

- a) **Initial Harvest:** Terminated by 50 sec. harvest timer. No temperature requirement.
- b) **Normal Harvest:** Terminated by temperature (47°F (7°C)) and time (50 sec. harvest timer).
Once the thermistor warms to 47°F (7°C), CB reads 4.5 kΩ from the thermistor and turns harvest termination over to the 50-sec. harvest timer.

2) VR2 Freeze Control

VR2 freeze control is for adjustment of the freeze cycle completion temperature (controls size of hole in ice cube). If adjustment to cube hole size is desired, follow the instructions below. See Fig. 1.

NOTICE

Do not adjust VR2 to the lowest temperature setting. This will result in freeze up.

- a) **Larger Hole:** Turn VR2 freeze control clockwise for a higher freeze cycle completion temperature (WARM) for shorter freeze time and ice cubes with larger diameter holes.
- b) **Smaller Hole:** Turn VR2 freeze control counterclockwise for a lower freeze cycle completion temperature (COLD) for longer freeze time and ice cubes with smaller diameter holes.

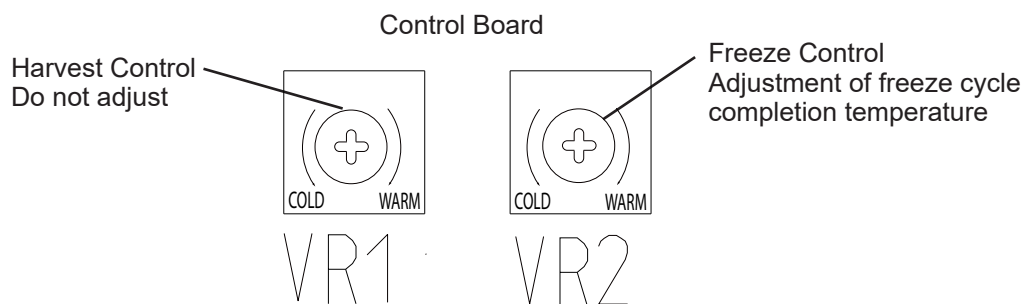

Fig. 1

C. LED Lights

1. Main Control Board LED Lights

1) LED 1 24VAC

Green LED 1 flashes to indicate proper 24VAC and continues to flash unless TBC or THCB X1 relay are open, control switch is moved to the "OFF" position, or appliance is unplugged.

2) LED 2 Freeze

Green LED 2 (PM) turns on at freeze cycle initiation and turns off at freeze cycle termination.

3) LED 3 Harvest

Green LED 3 (WV) turns on at harvest cycle initiation and turns off after 102-sec. water valve timer terminates.

2. Thermistor Control Board LED Lights (Aux. Code N-2 and later)

1) LED 1 115VAC (POWER)

Green LED 1 "POWER" turns on solid to indicate proper 115VAC and continues unless the control switch is moved to the "OFF" position, or appliance is unplugged.

2) LED 2 Icemaking (X1 Relay)

Green LED 2 turns on when THBC k Ω value is below the factory k Ω setting for icemaking. LED 2 turns off when THBC k Ω value is above the factory k Ω setting for shutdown.

Legend: **PM**—pump motor; **TBC**—thermostat bin control; **THBC**—thermistor bin control; **THCB**—thermistor control board; **WV**—inlet water valve

D. Control Switch

The control switch has three positions: "OFF," "ICE," and "WASH." In the "OFF" position power is still present at the DP connector and DP (if applicable). In the "WASH" position, PM and FM energize after the 50 sec. HT terminates (C-0 and earlier).

Note: When in the "WASH" position, FM also energizes.

Legend: **DP**—drain pump; **HT**—harvest timer; **FM**—fan motor; **PM**—pump motor

IV. Refrigeration Circuit and Component Service Information

⚠ WARNING

- This appliance should be diagnosed and repaired only by qualified service personnel to reduce the risk of death, electric shock, serious injury, or fire.
- Move the control switch to the "OFF" position, then unplug the appliance from the electrical outlet before servicing.
- **CHOKING HAZARD:** Ensure all components, fasteners, and thumbscrews are securely in place after the icemaker is serviced. Make sure that none have fallen into the ice storage bin.
- Make sure all food zones in the icemaker and ice storage bin are clean after service.

A. Refrigeration Circuit Service Information

⚠ WARNING

- Repairs requiring the refrigeration circuit to be opened must be performed by properly trained and EPA-certified service personnel.
- Use an electronic leak detector or soap bubbles to check for leaks. Add a trace of refrigerant to the system (if using an electronic leak detector), and then raise the pressure using nitrogen gas (140 PSIG). Do not use R-134a as a mixture with pressurized air for leak testing.

NOTICE

- Always recover the refrigerant and store it in an approved container. Do not discharge the refrigerant into the atmosphere.
- Do not leave the system open for longer than 15 min. when replacing or servicing parts. The Polyol Ester (POE) oils used in R-134a applications can absorb moisture quickly. Therefore it is important to prevent moisture from entering the system when replacing or servicing parts.
- Always install a new drier every time the sealed refrigeration system is opened. Do not replace the drier until after all other repair or replacement has been made. Install the new drier with the arrow on the drier in the direction of the refrigerant flow.
- When brazing, protect the drier by using a wet cloth to prevent the drier from overheating. Do not allow the drier to exceed 250°F (121°C).

1. Refrigerant Recovery

No refrigerant access valves are provided on this appliance. Using proper refrigerant practices, utilize a temporary tap-line valve on the high side to recover the refrigerant. Store the refrigerant in an approved container. Do not discharge the refrigerant into the atmosphere. After recovery is complete, replace the tap-line valve with a proper, permanent access valve.

2. Brazing

⚠ WARNING

- R-134a itself is not flammable at atmospheric pressure and temperatures up to 212°F (100°C).
- R-134a itself is not explosive or poisonous. However, when exposed to high temperatures (open flames), R-134a can be decomposed to form hydrofluoric acid and carbonyl fluoride both of which are hazardous.
- Do not use silver alloy or copper alloy containing arsenic.

1) Braze all fittings while purging with nitrogen gas flowing at a pressure of 3 to 4 PSIG.

NOTICE

- Always install a new drier every time the sealed refrigeration system is opened.
- Do not replace the drier until after all other repair or replacement has been made. Install the new drier with the arrow on the drier in the direction of the refrigerant flow.
- When brazing, protect the drier by using a wet cloth to prevent the drier from overheating. Do not allow the drier to exceed 250°F (121°C).

2) Use an electronic leak detector or soap bubbles to check for leaks. Add a trace of refrigerant to the system (if using an electronic leak detector), and then raise the pressure using nitrogen gas (140 PSIG). Do not use R-134a as a mixture with pressurized air for leak testing.

3. Evacuation and Recharge (R-134a)

1) Attach a vacuum pump to the system. Be sure the high-side charging hose is connected to the field-installed high-side access valve.

IMPORTANT

The vacuum level and vacuum pump may be the same as those for current refrigerants. However, the rubber hose and gauge manifold to be used for evacuation and refrigerant charge should be exclusively for POE oils.

- 2) Turn on the vacuum pump. Open the gauge manifold valves. Never allow the oil in the vacuum pump to flow backwards.
- 3) Allow the vacuum pump to pull down to a 29.9" Hg vacuum. Evacuating period depends on pump capacity.
- 4) Close the high-side valve on the gauge manifold.
- 5) Disconnect the gauge manifold hose from the vacuum pump and attach it to a refrigerant service cylinder. Remember to loosen the connection and purge the air from the hose. For the required refrigerant charge, see the rating label inside the icemaker. Hoshizaki recommends only virgin refrigerant or reclaimed refrigerant which meets ARI Standard 700 (latest edition) be used.

- 6) A liquid charge is recommended when charging an R-134a system. Place the service cylinder on the scales; if the service cylinder is not equipped with a dip tube, invert the service cylinder, then place it on the scales. Open the high-side valve on the gauge manifold.
- 7) Allow the system to charge with liquid until the proper charge weight is met.
- 8) Close the high-side valve on the gauge manifold, then close the refrigerant access valve (if applicable). Disconnect the gauge manifold hose.
- 9) Cap the access valve to prevent a possible leak.

B. Component Service Information

NOTICE	
When replacing a component listed below, see the notes to help ensure proper operation.	

Component	Notes
Compressor	Install a new drier and PTC relay.
Hot Gas Valve	<ul style="list-style-type: none"> • Replace the strainer. • Use copper tube of the same diameter and length when replacing valve lines.
Pump Motor	<p>Auxiliary Code G-0: Order SP-5219: This kit includes pump motor 3A8334-01, in-line fuse holder, a 1.25A fuse, and a new wiring label. Pump motor 3A8334-01 does not utilize a capacitor or a ground wire.</p> <p>Auxiliary Code H-0 to M-2: Order SP-5687.</p> <p>Auxiliary Code N-0 and later: Order pump motor 3B1175-01.</p>
Evaporator Thermistor	<ul style="list-style-type: none"> • Attach the new thermistor to the evaporator in the same location as the previous thermistor. • Smoothly fill the recessed area of the thermistor holder with high thermal conductive type sealant. KE-4560 RTV (manufactured by ShinEtsu Silicones) or equivalent are recommended. • Secure the thermistor with the holder. • Be very careful to prevent damage to the leads.

V. Maintenance

This appliance must be maintained in accordance with the instruction manual and labels provided with the appliance. Consult with your local Hoshizaki Certified Service Representative about maintenance service.

WARNING

- Only qualified service technicians should service this appliance.
- Failure to install, operate, and maintain the appliance in accordance with this manual will adversely affect safety, performance, component life, and warranty coverage.
- Move the control switch to the "OFF" position and unplug the appliance from the electrical outlet before servicing.
- To reduce the risk of electric shock, do not touch the control switch or plug with damp hands.
- **CHOKING HAZARD:** Ensure all components, fasteners, and thumbscrews are securely in place after any maintenance is performed. Make sure that none have fallen into the ice storage bin.
- After service, make sure that there are no wires pinched between the panels and appliance. Make sure you do not damage or pinch the water supply line, drain line, or power cord.

A. Maintenance Schedule

The maintenance schedule below is a guideline. More frequent maintenance may be required depending on water quality, the appliance's environment, and local sanitation regulations.

Maintenance Schedule		
Frequency	Area	Task
Weekly	Scoop	Clean the scoop using a neutral cleaner. Rinse thoroughly after cleaning.
Monthly	External Water Filters	Check for proper pressure and change if necessary.
	Appliance Exterior	Wipe down with clean, soft cloth. Use a damp cloth containing a neutral cleaner to wipe off oil or dirt build up. Clean any chlorine staining (rust colored spots) using a non-abrasive cleaner like Zud or Bon Ami.
Every 3 Months	Ice Storage Bin Drain	Maintain as outlined in the instruction manual or maintenance label.
Yearly	Appliance and Ice Storage Bin	Clean and sanitize per the cleaning and sanitizing instructions provided in the instruction manual.
	Optional Drain Pump (HS-5061)	Test as outlined in "V.B. Optional Drain Pump HS-5061 ."
	Water Supply Inlet	Close the icemaker water supply line shut-off valve and drain the water system. Clean the water supply inlet screen.
	Condenser	Inspect. Clean if necessary.
	Water Hoses	Inspect the water hoses and clean/replace if necessary.

B. Optional Drain Pump HS-5061

If the optional drain pump (HS-5061) is installed, test its operation at least once a year as outlined below. Note that the pump has power even when the control switch is in the "OFF" position.

- 1) Move the control switch to the "OFF" position, then unplug the appliance from the electrical outlet. **WARNING! To reduce the risk of electric shock, do not touch the control switch or plug with damp hands.**
- 2) Remove all ice from the ice storage bin.
- 3) Plug the appliance back in.
- 4) Slowly pour 24 to 30 oz. (710 to 890 ml) of water over the ice storage bin drain hole in the ice storage bin.
- 5) If water pumps out properly and the drain pump then de-energizes, proceed to step 6. If water does not pump out, confirm 115VAC to drain pump, replace as needed.
- 6) Move the control switch to the "ICE" position.
- 7) Pour another 24 to 30 oz. (710 to 890 ml) of water into the ice storage bin, then completely restrict the discharge hose while the drain pump is operating. See Fig. 2. Pour more water into the ice storage bin until the appliance turns off. The drain pump will continue to operate. Check for leaks.
- 8) Remove the discharge hose restriction and allow the water to be pumped out normally. Power to the appliance will be restored when the water in the drain pump returns to a normal level.
- 9) If the appliance fails to turn off with the discharge hose restricted or the drain pump fails to pump out the water, replace the drain pump.

Fig. 2

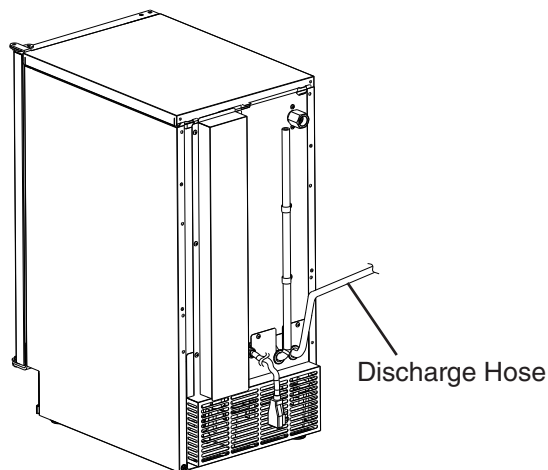

VI. Preparing the Icemaker for Periods of Non-Use

During extended periods of non-use, extended absences, or in sub-freezing temperatures, follow the instructions below. When the appliance is not used for two or three days under normal conditions, it is sufficient to move the control switch to the "OFF" position.

⚠ WARNING

Only qualified service technicians should service this appliance.

NOTICE

During extended periods of non-use, extended absences, or in sub-freezing temperatures, follow the instructions below to reduce the risk of costly water damage.
--

- 1) Close the water supply line shut-off valve, then open the water supply line drain valve.
- 2) Allow the line to drain by gravity.
- 3) Attach a compressed air or carbon dioxide supply to the water supply line drain.
- 4) Move the control switch to the "ICE" position.
- 5) Blow the water supply line out using the compressed air or carbon dioxide supply.
- 6) Move the control switch to the "OFF" position.
- 7) Unplug the appliance.
- 8) Close the water supply line drain valve.
- 9) Remove the water tank hose and drain the water tank.
- 10) Optional drain pump: remove the drain pump and empty the drain pump reservoir. Replace the drain pump in its original position.
- 11) Remove all ice from the ice storage bin. Clean the ice storage bin liner using a neutral cleaner. Rinse thoroughly after cleaning.

VII. Disposal

This appliance contains refrigerant and must be disposed of in accordance with applicable national, state, and local codes and regulations. Refrigerant must be recovered by properly certified service personnel.

VIII. Technical Information

We reserve the right to make changes in specifications and design without prior notice.

A. Specification and Performance Data

Pressure data is recorded at 5 min. into freezing cycle. The data not in bold should be used for reference only.

1. AM-50BAJ(-DS)

Specification Sheet

AC SUPPLY VOLTAGE	115-120/60/1	
AMPERAGE	4.1 A	
MINIMUM CIRCUIT AMPACITY	15 A	
MAXIMUM FUSE SIZE	15 A	
ELECTRIC & WATER CONSUMPTION	90/70°F	70/50°F
ELECTRIC W (kWH/100 lbs.)	244(17.0)	222(10.4)
WATER gal./24HR (gal./100 lbs.)	24.0(71.0)	44.0(85.0)
SHAPE OF ICE	Column Φ20 x H 27mm	
ICE PRODUCTION PER CYCLE	0.6 lbs. (0.3 kg) 24pcs.	
APPROXIMATE STORAGE CAPACITY	27 lbs. (12.5 kg) [Bin Control Setting 22 lbs.(10.0 kg)]	
CUBE CONTROL SYSTEM	Thermistor. Timer	
BIN CONTROL SYSTEM	Thermistor	
REFRIGERANT CHARGE	R134a, 0 lb. 4.2 oz. (120 g)	

Performance Data Sheet

APPROXIMATE ICE PRODUCTION PER 24 HR.	AMBIENT TEMP. (°F/°C)	WATER TEMP. (°F/°C)					
		50/10		70/21		90/32	
	70/21	51	<u>23</u>	46	<u>21</u>	43	<u>20</u>
	80/27	47	<u>22</u>	40	<u>18</u>	38	<u>17</u>
APPROXIMATE ELECTRIC CONSUMPTION	70/21	222		228		235	
	80/27	227		237		242	
	90/32	228		244		250	
watts	100/38	237		246		255	
APPROXIMATE WATER CONSUMPTION PER 24 HR.	70/21	44	<u>0.17</u>	38	<u>0.14</u>	33	<u>0.12</u>
	80/27	39	<u>0.15</u>	31	<u>0.12</u>	27	<u>0.10</u>
	90/32	38	<u>0.14</u>	24	<u>0.09</u>	20	<u>0.08</u>
gal./day m ³ /day	100/38	31	<u>0.12</u>	23	<u>0.09</u>	16	<u>0.06</u>
FREEZING CYCLE TIME	70/21	16		19		23	
	80/27	18		21		26	
	90/32	19		24		29	
min.	100/38	25		29		33	
HARVEST CYCLE TIME	70/21	3.1		2		2	
	80/27	3		2		2	
	90/32	3		2.4		2	
min.	100/38	3		2		2.1	
HEAD PRESSURE	70/21	140	<u>9.8</u>	152	<u>10.7</u>	175	<u>12.3</u>
	80/27	149	<u>10.5</u>	167	<u>11.8</u>	194	<u>13.7</u>
	90/32	152	<u>10.7</u>	180	<u>12.7</u>	206	<u>14.5</u>
PSIG kg/cm ² G	100/38	159	<u>11.2</u>	186	<u>13.1</u>	230	<u>16.2</u>
SUCTION PRESSURE	70/21	15	<u>1.1</u>	16	<u>1.2</u>	19	<u>1.3</u>
	80/27	16	<u>1.1</u>	18	<u>1.3</u>	21	<u>1.5</u>
	90/32	16	<u>1.2</u>	20	<u>1.4</u>	23	<u>1.6</u>
PSIG kg/cm ² G	100/38	17	<u>1.2</u>	21	<u>1.4</u>	25	<u>1.8</u>
TOTAL HEAT OF REJECTION FROM CONDENSER	1,900 BTU/h [AT 90°F (32°C) / WT 70°F (21°C)]						
TOTAL HEAT OF REJECTION FROM COMPRESSOR	800 BTU/h [AT 90°F (32°C) / WT 70°F (21°C)]						

2. AM-50BAJ-AD(ADDS)

Specification Sheet

AC SUPPLY VOLTAGE	115-120/60/1	
AMPERAGE	4.1 A	
MINIMUM CIRCUIT AMPACITY	15 A	
MAXIMUM FUSE SIZE	15 A	
ELECTRIC & WATER CONSUMPTION	90/70°F	70/50°F
ELECTRIC W (kWH/100 lbs.)	238(16.8)	227(9.9)
WATER gal./24HR (gal./100 lbs.)	22.0(63.9)	30.0(53.7)
SHAPE OF ICE	Column Φ20 x H 27mm	
ICE PRODUCTION PER CYCLE	0.6 lbs. (0.3 kg) 24pcs.	
APPROXIMATE STORAGE CAPACITY	27 lbs. (12.5 kg) [Bin Control Setting 22 lbs.(10.0 kg)]	
CUBE CONTROL SYSTEM	Thermistor. Timer	
BIN CONTROL SYSTEM	Thermistor	
REFRIGERANT CHARGE	R134a, 0 lb. 4.2 oz. (120g)	

Performance Data Sheet

APPROXIMATE ICE PRODUCTION PER 24 HR.	AMBIENT TEMP. (°F/°C)	WATER TEMP. (°F/°C)					
		50/10		70/21		90/32	
	70/21	55	<u>25</u>	49	<u>22</u>	46	<u>21</u>
	80/27	50	<u>23</u>	41	<u>18</u>	41	<u>19</u>
	90/32	49	<u>22</u>	34	<u>15</u>	33	<u>15</u>
lbs./day kg./day	100/38	42	<u>19</u>	34	<u>15</u>	32	<u>15</u>
APPROXIMATE ELECTRIC CONSUMPTION	70/21	227		230		237	
	80/27	229		234		243	
	90/32	230		238		246	
watts	100/38	236		240		253	
APPROXIMATE WATER CONSUMPTION PER 24 HR.	70/21	30	<u>0.11</u>	27	<u>0.10</u>	24	<u>0.09</u>
	80/27	28	<u>0.11</u>	24	<u>0.09</u>	22	<u>0.08</u>
	90/32	27	<u>0.10</u>	22	<u>0.08</u>	19	<u>0.07</u>
gal./day m ³ /day	100/38	24	<u>0.09</u>	21	<u>0.08</u>	17	<u>0.06</u>
FREEZING CYCLE TIME	70/21	15		17		20	
	80/27	16		19		23	
	90/32	17		21		25	
min.	100/38	20		22		29	
HARVEST CYCLE TIME	70/21	2.5		2.5		2.5	
	80/27	2.5		2		2	
	90/32	2		2		2	
min.	100/38	2		2		2	
HEAD PRESSURE	70/21	145	<u>10.2</u>	161	<u>11.3</u>	182	<u>12.8</u>
	80/27	157	<u>11.1</u>	182	<u>12.8</u>	202	<u>14.2</u>
	90/32	161	<u>11.3</u>	200	<u>14.1</u>	221	<u>15.5</u>
PSIG kg/cm ² G	100/38	165	<u>11.6</u>	205	<u>14.4</u>	240	<u>16.9</u>
SUCTION PRESSURE	70/21	18	<u>1.3</u>	22	<u>1.5</u>	25	<u>1.7</u>
	80/27	21	<u>1.5</u>	26	<u>1.8</u>	28	<u>2.0</u>
	90/32	22	<u>1.5</u>	30	<u>2.1</u>	33	<u>2.3</u>
PSIG kg/cm ² G	100/38	22	<u>1.5</u>	31	<u>2.2</u>	35	<u>2.5</u>
TOTAL HEAT OF REJECTION FROM CONDENSER	1,900 BTU/h [AT 90°F (32°C) / WT 70°F (21°C)]						
TOTAL HEAT OF REJECTION FROM COMPRESSOR	800 BTU/h [AT 90°F (32°C) / WT 70°F (21°C)]						

B. Wiring Diagrams

1a) AM-50BAJ(-DS)(-AD)(-ADDS) Auxiliary Code J-0 and Earlier

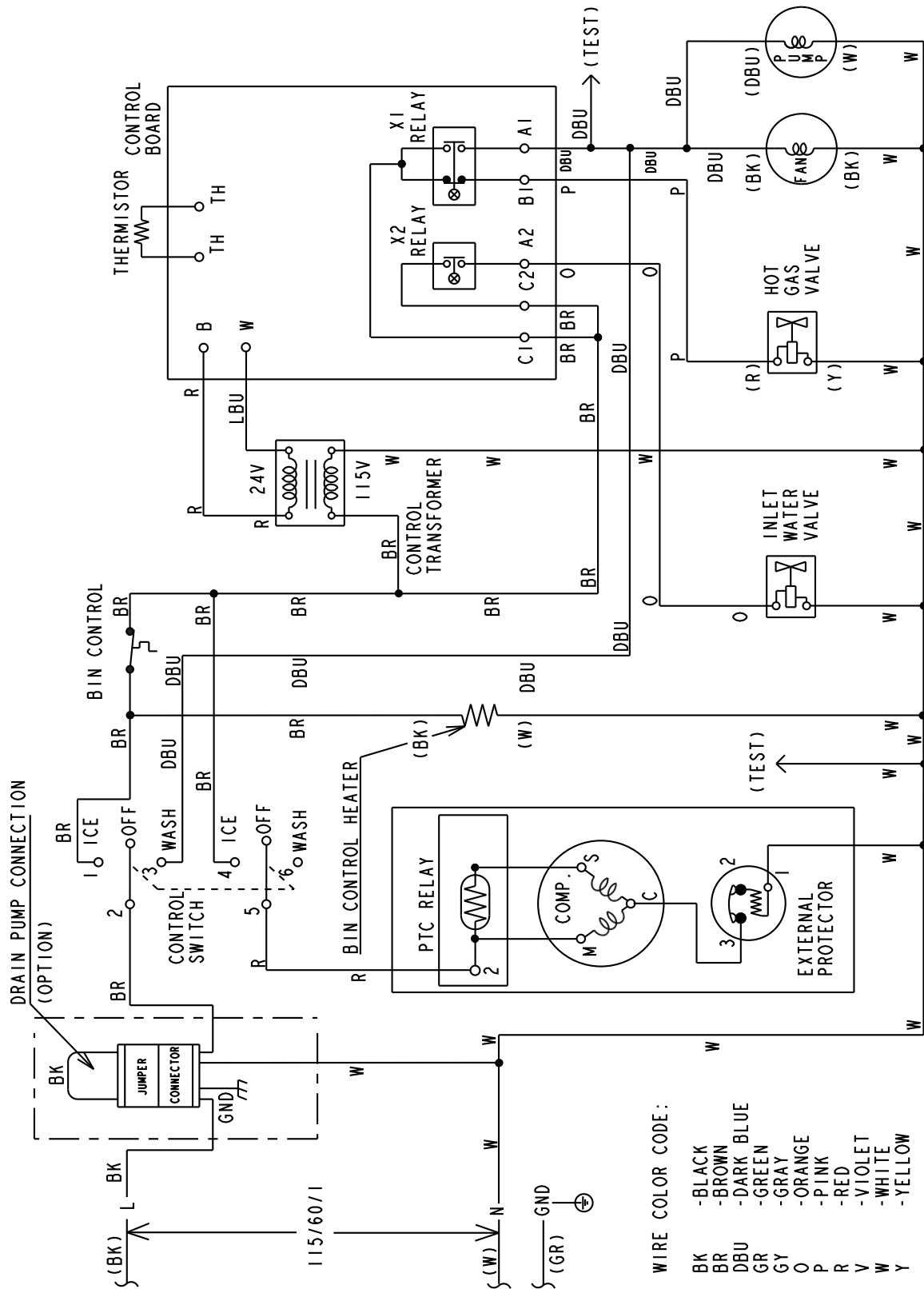

1c) AM-50BAJ(-DS)(-AD)(-ADDS) Auxiliary Code M-0 to M-2

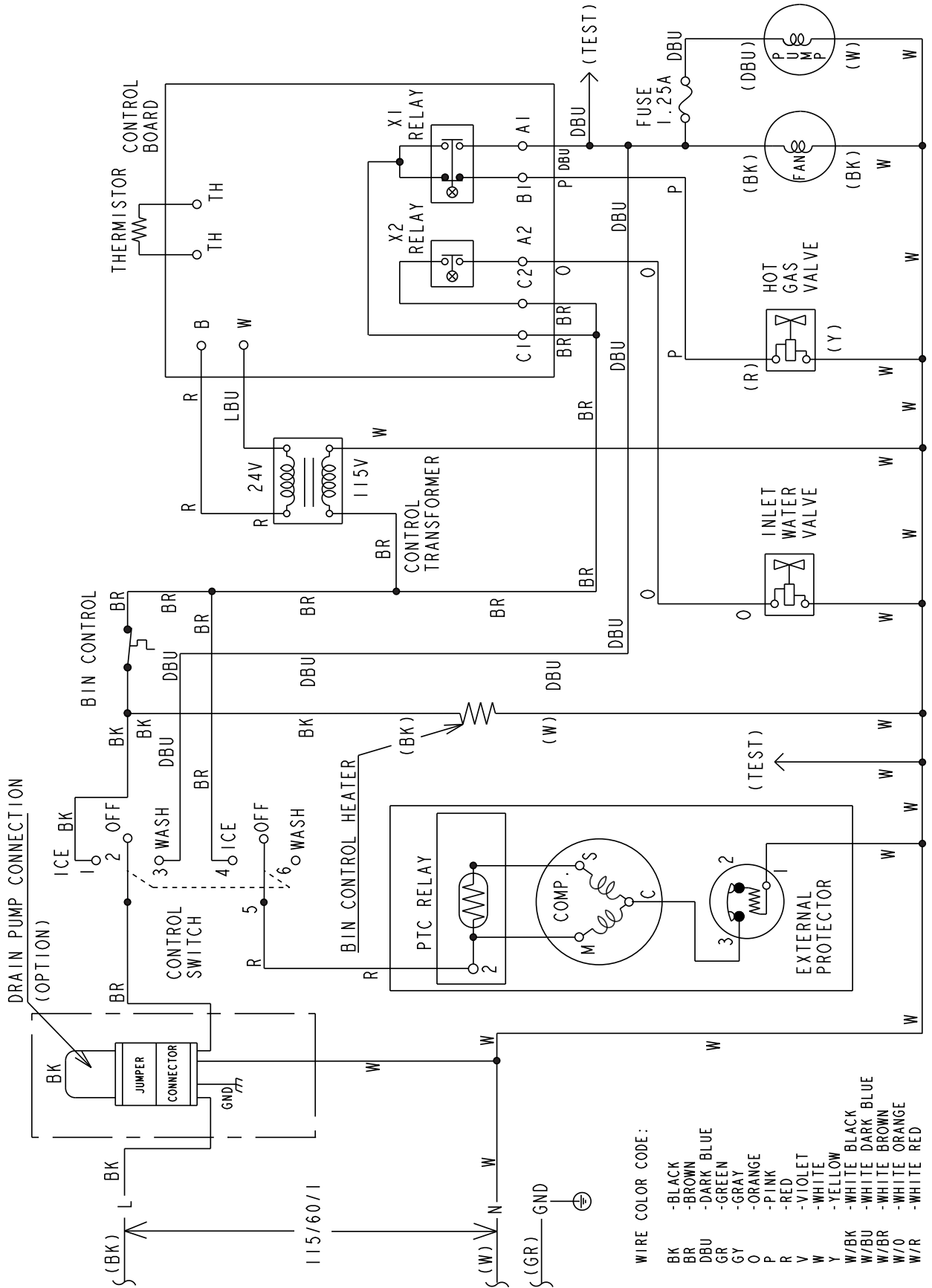

1d) AM-50BAJ(-DS)(-AD)(-ADDS) Auxiliary Code N-0 to N-1

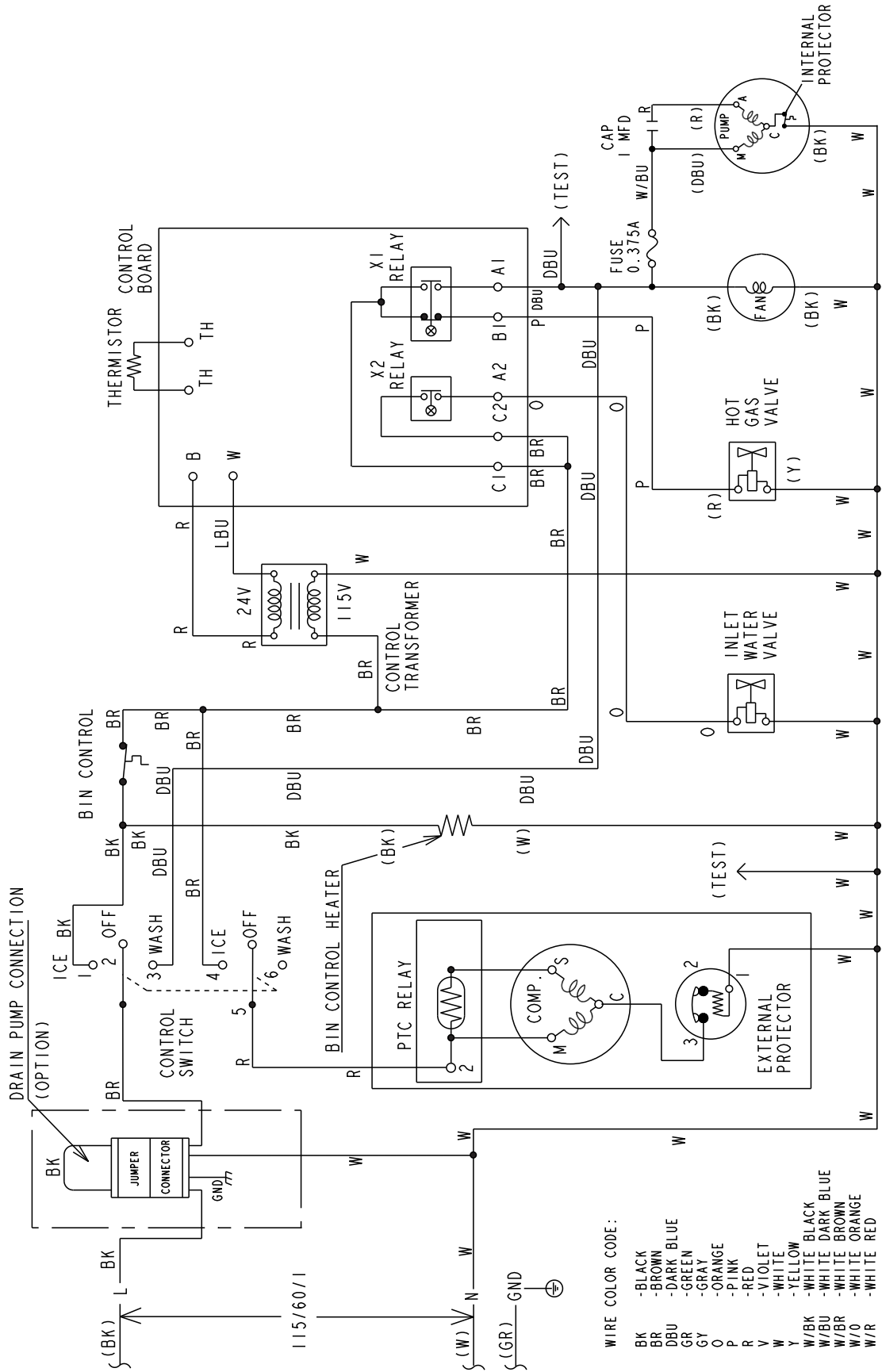

1e) AM-50BAJ(-DS)(-AD)(-ADDS) Auxiliary Code N-2 and Later

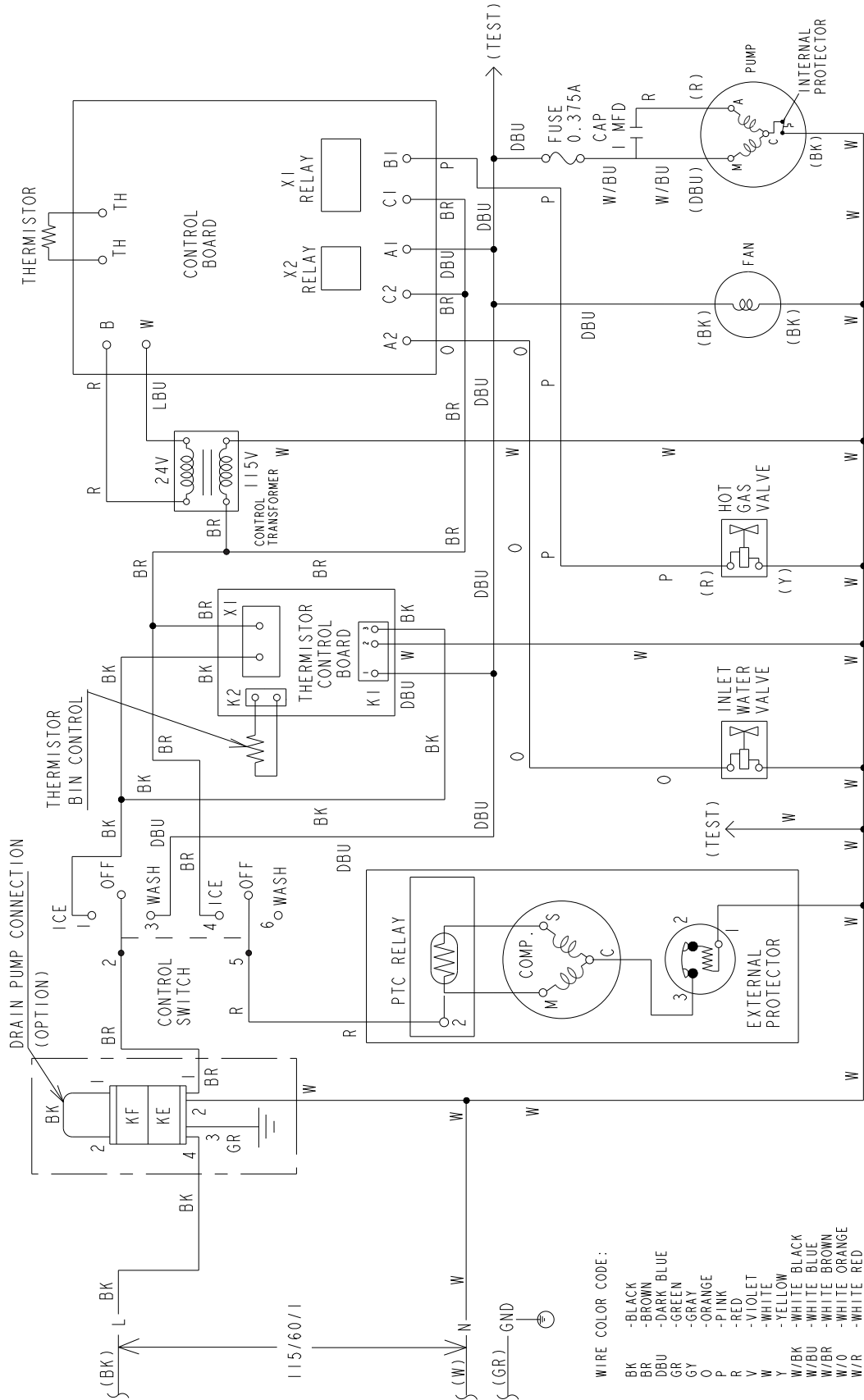

2) HS-5061 Optional Drain Pump

