



HOSHIZAKI

Service Manual

Self-Contained Cubelet

Models

C-101BAH

C-101BAH-DS

C-101BAH-AD

C-101BAH-ADDS



hoshizakiamerica.com

Number: 73195
Issued: 11-7-2013
Revised: 10-31-2017

⚠ WARNING

Only qualified service technicians should install and service the appliance. To obtain the name and phone number of your local Hoshizaki Certified Service Representative, visit www.hoshizaki.com. No service should be undertaken until the technician has thoroughly read this Service Manual. Failure to service and maintain the appliance in accordance with this manual will adversely affect safety, performance, component life, and warranty coverage and may result in costly water damage. Proper installation is the responsibility of the installer. Product failure or property damage due to improper installation is not covered under warranty.

Hoshizaki provides this manual primarily to assist qualified service technicians in the service of the appliance.

Should the reader have any questions or concerns which have not been satisfactorily addressed, please call, send an e-mail message, or write to the Hoshizaki Technical Support Department for assistance.

Phone: 1-800-233-1940; (770) 487-2331

Fax: 1-800-843-1056; (770) 487-3360

E-mail: techsupport@hoshizaki.com

HOSHIZAKI AMERICA, INC.

618 Highway 74 South

Peachtree City, GA 30269

Attn: Hoshizaki Technical Support Department

Web Site: www.hoshizaki.com

NOTE: To expedite assistance, all correspondence/communication **MUST** include the following information:

- Model Number _____
- Serial Number _____
- Complete and detailed explanation of the problem.

IMPORTANT

This manual should be read carefully before the appliance is serviced. Read the warnings and guidelines contained in this manual carefully as they provide essential information for the continued safe use, service, and maintenance of the appliance. Retain this manual for any further reference that may be necessary.

CONTENTS

Important Safety Information	4
I. Construction and Water/Refrigeration Circuit Diagram	7
A. Construction	7
1. Icemaker	7
2. Ice Making Assembly	8
3. Water/Refrigeration Circuit Diagram	9
II. Sequence of Operation and Service Diagnosis	10
A. Sequence of Operation Flow Chart	10
B. Service Diagnosis	11
1. Ice Production Check	11
2. Diagnostic Procedure	11
C. Bin Control Check	14
D. Float Switch Check and Cleaning	15
1. Float Switch Check	15
2. Float Switch Cleaning	15
E. Optional Drain Pump HS-5061	17
1. Overview	17
2. Drain Pump Check.....	17
F. Diagnostic Tables	18
III. Controls and Relays.....	20
A. Control Switch	20
B. Time Delay Relay	20
C. Water Control Relay	20
IV. Refrigeration Circuit and Component Service Information.....	21
A. Refrigeration Circuit Service Information	21
B. Component Service Information.....	24
1. Upper Bearing Wear Check	26
2. Removal and Replacement of Extruding Head.....	27
3. Removal and Replacement of Auger	28
4. Removal and Replacement of Evaporator	29
5. Removal and Replacement of Mechanical Seal and Lower Housing	30
6. Removal and Replacement of Gear Motor	32
V. Maintenance	33
A. Maintenance Schedule.....	34
VI. Preparing the Appliance for Periods of Non-Use	35
VII. Disposal.....	37
VIII. Technical Information.....	38
A. Specification and Performance Data	38
B. Wiring Diagrams.....	39
1. C-101BAH(-DS)(-AD)(-ADDS).....	39
2. Optional Drain Pump HS-5061	40

Important Safety Information

Throughout this manual, notices appear to bring your attention to situations which could result in death, serious injury, damage to the appliance, or damage to property.

⚠ WARNING Indicates a hazardous situation which could result in death or serious injury.

NOTICE Indicates a situation which could result in damage to the appliance or property.

IMPORTANT Indicates important information about the use and care of the appliance.

⚠ WARNING

The appliance should be destined only to the use for which it has been expressly conceived. Any other use should be considered improper and therefore dangerous. The manufacturer cannot be held responsible for injury or damage resulting from improper, incorrect, and unreasonable use. Failure to service and maintain the appliance in accordance with this manual will adversely affect safety, performance, component life, and warranty coverage and may result in costly water damage.

To reduce the risk of death, electric shock, serious injury, or fire, follow basic precautions including the following:

- Only qualified service technicians should install and service the appliance.
- The appliance must be installed in accordance with applicable national, state, and local codes and regulations.
- The appliance requires an independent power supply of proper capacity. See the nameplate for electrical specifications. Failure to use an independent power supply of proper capacity can result in a tripped breaker, blown fuse, damage to existing wiring, or component failure. This could lead to heat generation or fire.
- **THE APPLIANCE MUST BE GROUNDED:** The appliance is equipped with a NEMA 5-15 three-prong grounding plug  to reduce the risk of potential shock hazards. It must be plugged into a properly grounded, independent 3-prong wall outlet. If the outlet is a 2-prong outlet, it is your personal responsibility to have a qualified electrician replace it with a properly grounded, independent 3-prong wall outlet. Do not remove the ground prong from the power cord and do not use an adapter plug. Failure to properly ground the appliance could result in death or serious injury.
- Do not use an extension cord.
- To reduce the risk of electric shock, do not touch the control switch or plug with damp hands. Make sure the control switch is in the "OFF" position before plugging in or unplugging the appliance.
- Do not use an appliance with a damaged power cord. The power cord should not be altered, jerked, bundled, weighed down, pinched, or tangled. Such actions could result in electric shock or fire. To unplug the appliance, be sure to pull the plug, not the cord, and do not jerk the cord.
- Do not make any alterations to the appliance. Alterations could result in electric shock, injury, fire, or damage to the appliance.

⚠ WARNING, continued

- Do not place fingers or any other objects into the ice discharge opening.
- The appliance is not intended for use by persons (including children) with reduced physical, sensory, or mental capabilities, or lack of experience and knowledge, unless they have been given supervision or instruction concerning use of the appliance by a person responsible for their safety.
- Young children should be properly supervised around the appliance.
- Do not climb, stand, or hang on the appliance or appliance door or allow children or animals to do so. Serious injury could occur or the appliance could be damaged.
- Be careful not to pinch fingers when opening and closing the door. Be careful when opening and closing the door when children are in the area.
- Do not use combustible spray or place volatile or flammable substances near the appliance. They might catch fire.
- Keep the area around the appliance clean. Dirt, dust, or insects in the appliance could cause harm to individuals or damage to the appliance.

NOTICE

- Protect the floor when moving the appliance to prevent damage to the floor.
- Follow the water supply, drain connection, and maintenance instructions carefully to reduce the risk of costly water damage.
- In areas where water damage is a concern, install in a contained area with a floor drain.
- Install the appliance in a location that stays above freezing. Normal operating ambient temperature must be within 45°F to 100°F (7°C to 38°C).
- If using the optional drain pump ([HS-5061](#)), test its operation every time the appliance is cleaned and sanitized. See "II.E.2. Drain Pump Check" for details. If the optional drain pump is not operating properly, water could back up and overflow, leading to costly water damage.
- If water collects in the bin and will not drain, turn off the appliance and close the water supply line shut-off valve. Locate and resolve the issue.
- To help ensure that the storage bin drain remains clear, follow the storage bin drain instructions in the instruction manual once every 3 months or as often as necessary for conditions. If the storage bin drain becomes clogged, water could build up in the bin and overflow, leading to costly water damage.
- If water seeps from the base of the appliance, turn off the appliance and close the water supply line shut-off valve. Locate and resolve the issue. Failure to do so could lead to costly water damage.
- Do not leave the appliance on during extended periods of non-use, extended absences, or in sub-freezing temperatures. To properly prepare the appliance for these occasions, follow the instructions in "VI. Preparing the Appliance for Periods of Non-Use."

NOTICE, continued

- Keep ventilation openings, in the appliance enclosure or in the built-in structure, clear of obstruction.
- Do not place objects on top of the appliance.
- The storage bin is for ice use only. Do not store anything else in the storage bin.

I. Construction and Water/Refrigeration Circuit Diagram

A. Construction

1. Icemaker

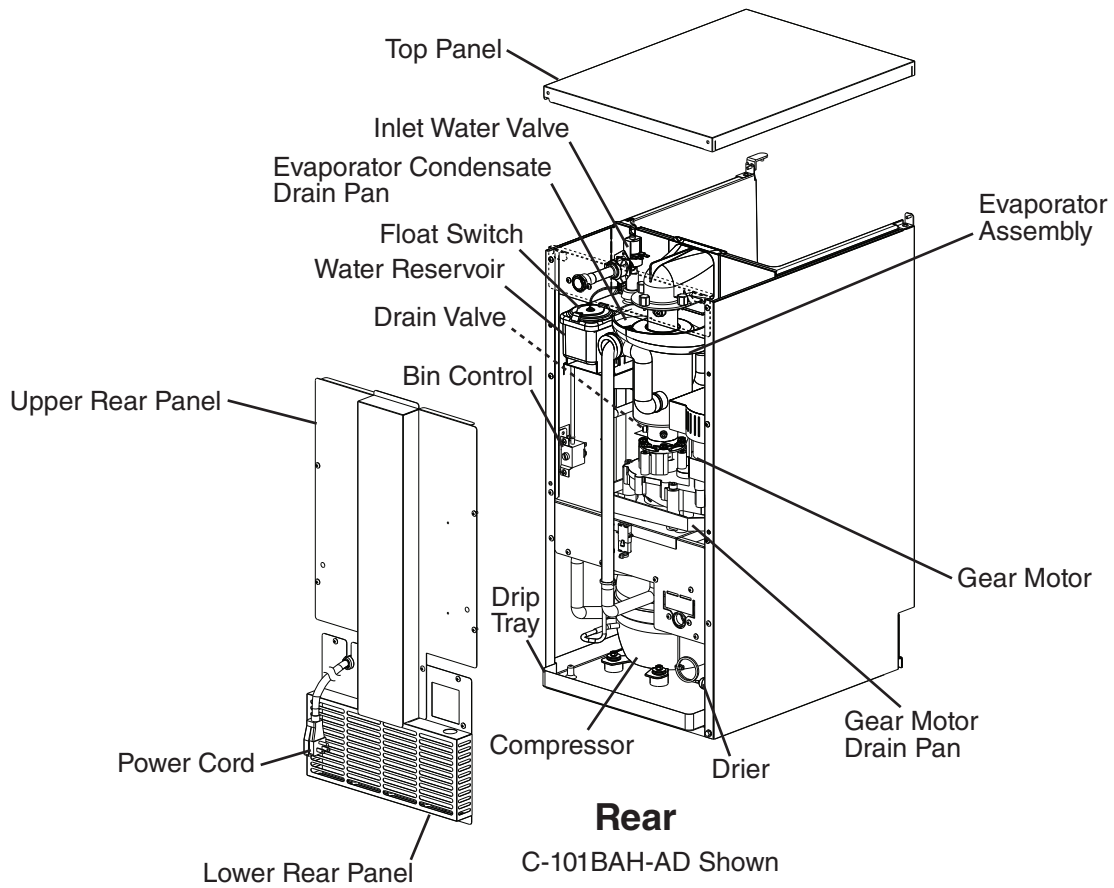
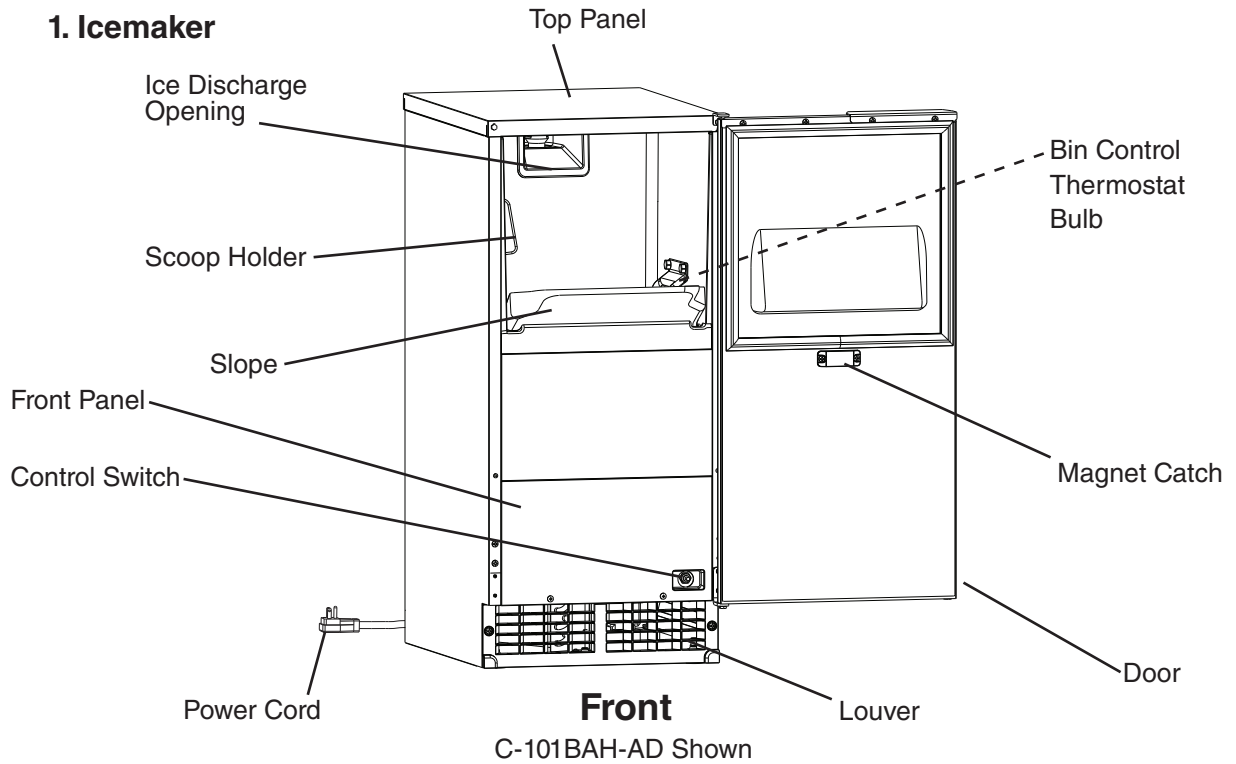

2. Ice Making Assembly

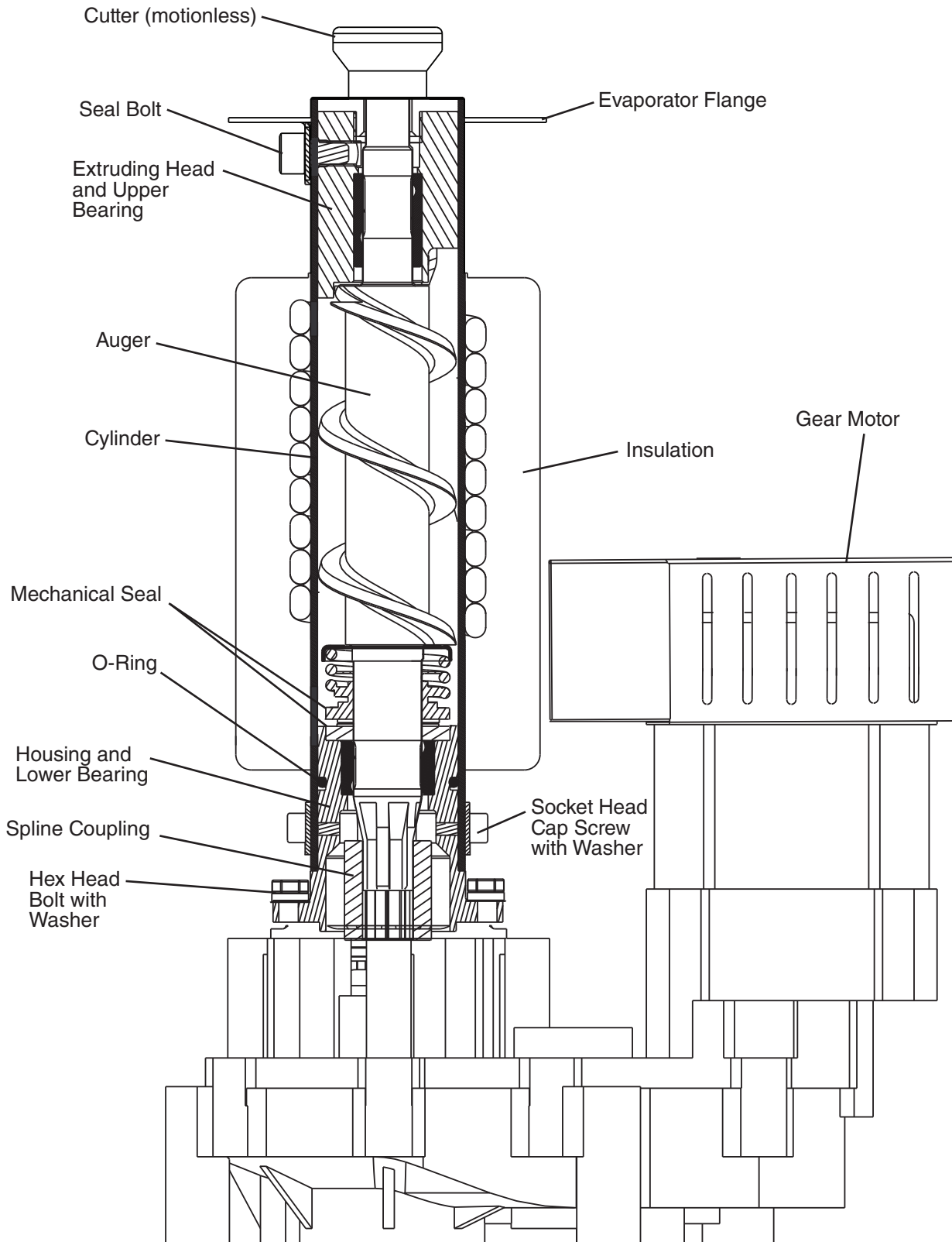

3. Water/Refrigeration Circuit Diagram

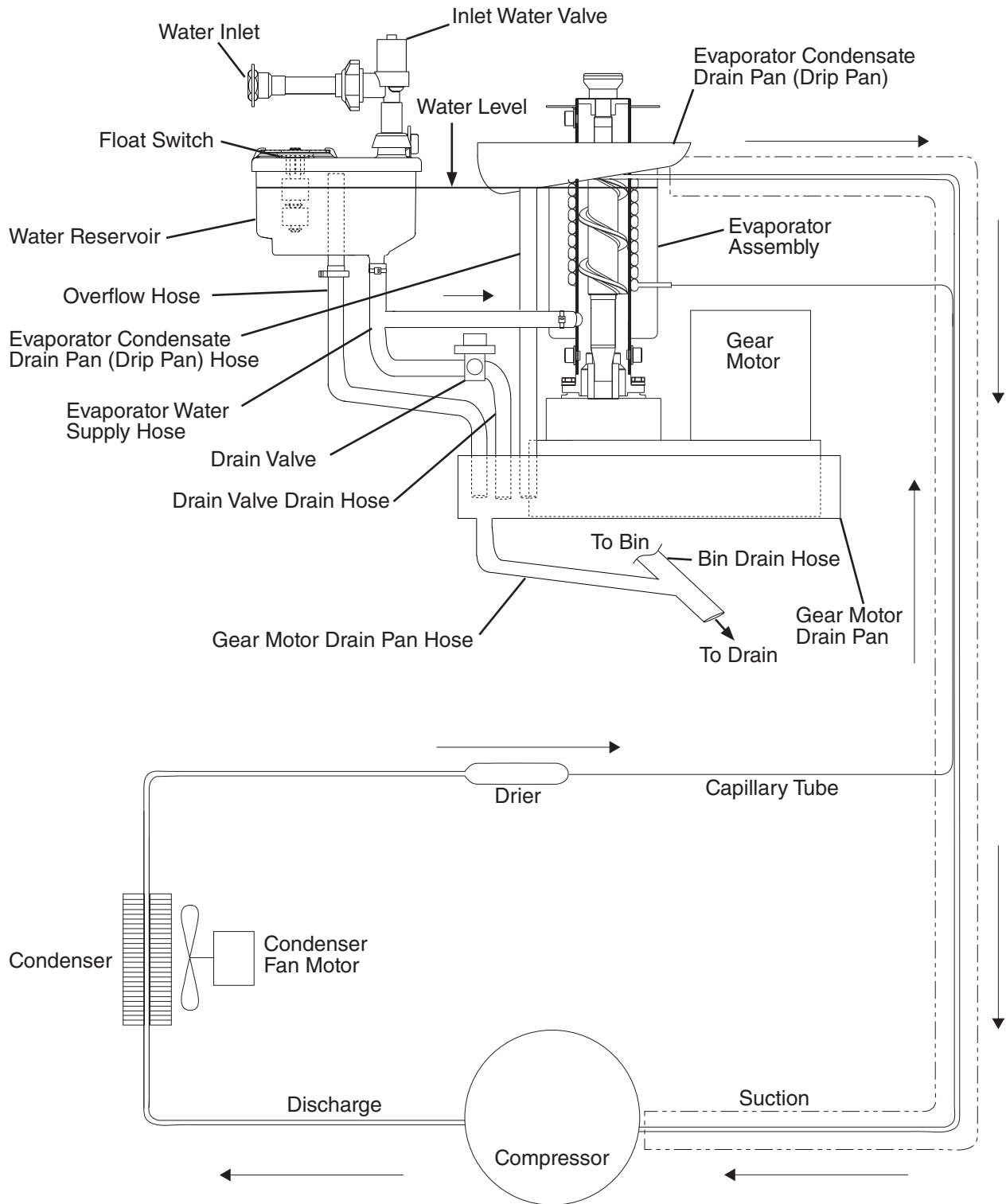

II. Sequence of Operation and Service Diagnosis

A. Sequence of Operation Flow Chart

C-101BAH(-DS)(-AD)(-ADDS) Series Sequence Flow Chart

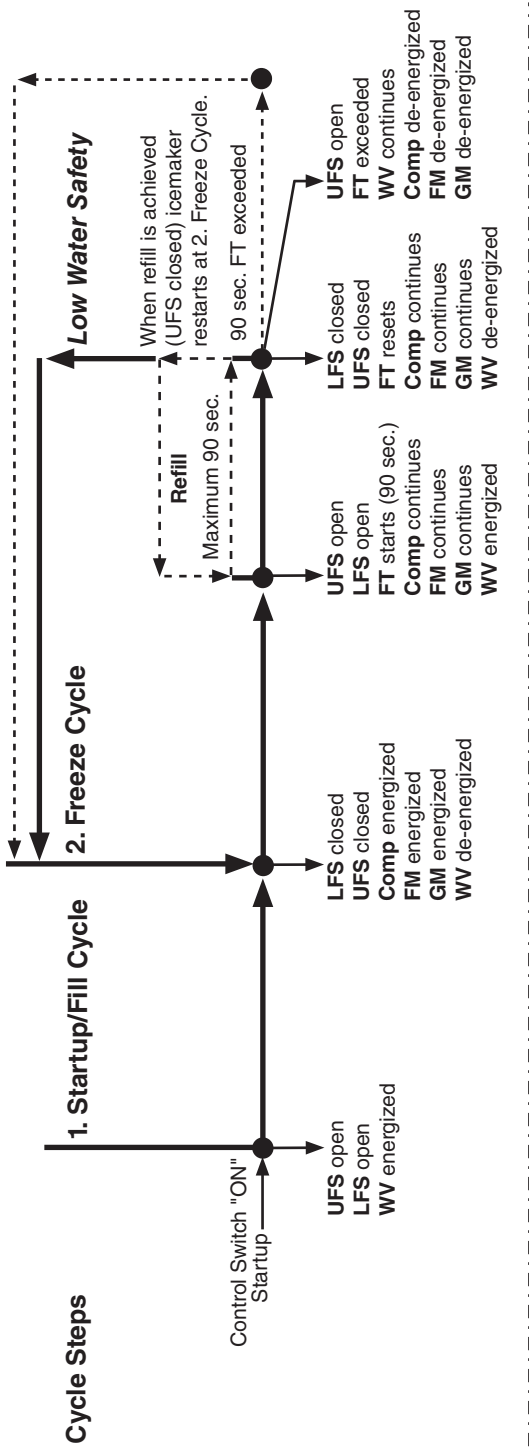

Legend:

BC	-bin control
Comp	-compressor
DV	-drain valve
DP	-drain pump (optional)
FM	-fan motor
FT	-fill timer (time delay relay)
GM	-gear motor
LFS	-lower float switch
UFS	-upper float switch
WV	-inlet water valve

- **Optional Drain Pump HS-5061**
Drain pump has 115VAC when appliance is plugged into electrical outlet. 115VAC remains at drain pump until appliance is unplugged from the electrical outlet.
- **Control Switch in the "DRAIN" Position**
When the control switch is in the "DRAIN" position, 115VAC is supplied to the drain valve.

B. Service Diagnosis

WARNING

- This appliance should be diagnosed and repaired only by qualified service personnel to reduce the risk of death, electric shock, serious injury, or fire.
- Risk of electric shock. Use extreme caution and exercise safe electrical practices.
- Moving parts (e.g., fan blade) can crush and cut. Keep hands clear.
- **CHOKING HAZARD:** Ensure all components, fasteners, and thumbscrews are securely in place after the appliance is serviced. Make sure that none have fallen into the storage bin.
- Make sure all food zones in the appliance and storage bin are clean after service.
- After service, make sure that there are no wires pinched between the panels and icemaker. Make sure you do not damage or pinch the water supply line, drain line, or power cord.

1. Ice Production Check

To check production, prepare a bucket or pan to catch the ice and a set of scales to weigh the ice. After the appliance has operated for 10 to 20 minutes, catch the ice production for 10 minutes. Weigh the ice to establish the batch weight. Multiply the batch weight by 144 for the total production in 24 hours. When confirming production or diagnosing low production, see "VIII.A. Specification and Performance Data" for typical production information.

2. Diagnostic Procedure

This diagnostic procedure is a sequence check that allows you to diagnose the electrical system and components. Before proceeding, check for correct installation, proper voltage per appliance nameplate, and adequate water pressure (7 to 113 PSIG).

Note: • When checking high voltage (115VAC), always choose a white (W) neutral wire to establish a good neutral connection.

- Time Delay Relay: 90 sec. low water safety circuit. Controlled by LFS and UFS and water control relay.
 - Optional drain pump ([HS-5061](#)) has 115VAC power supply as soon as the appliance is plugged into the electrical outlet.
- 1) Confirm the appliance is plugged into the electrical outlet, supply voltage is correct per nameplate.
 - 2) Move the control switch to the "DRAIN" position. **DV Diagnosis:** If DV does not energize, check for 115VAC at control switch terminal #3 (W/DBU) to neutral (W). If 115VAC is not present, check control switch continuity, optional drain pump connector/jumper and safety switch, and power supply. If 115VAC is present, check DV coil continuity. Replace as needed. If optional drain pump is installed, see "II.E. Optional Drain Pump [HS-5061](#)."

- 3) After all of the water has drained, move the control switch to the "OFF" position, then unplug the appliance.
- 4) Remove the front panel, louver, and upper and lower rear panels.
- 5) Remove the screws securing the control box, then gently pull out the control box and secure it in a safe position. Remove the control box cover.
- 6) Plug the appliance back into the electrical outlet.
- 7) **Startup/Fill Cycle**—Move the control switch to the "ICE" position. With LFS and UFS open, WV energizes. Reservoir fills, LFS closes. Nothing happens at this time. Reservoir continues to fill until UFS closes.
Diagnosis: Check that reservoir fills. If not, check water supply line shut-off valve, water filters, and WV screen. Next, check for 115VAC at WV. If 115VAC is not present at WV, check for 115VAC at WCR #8 (BK) to WCR #7 (W). If 115VAC is present, confirm that UFS is open. See "II.D.1. Float Switch Check." If 115VAC is not present and WV is not energized, check WCR #2 (O) to neutral (W) and #6 (BR) to neutral (W). If 115VAC is not present at WCR #6 (BR) to neutral (W), check control switch position and continuity. Also check wire connections to WCR. If 115VAC is present at WCR #6 (BR) to neutral (W) and not present at WCR #2 (O) to neutral (W), replace WCR. If 115VAC is present at WCR #2 (O) to neutral (W), check WV solenoid continuity. If open, replace WV.
Fill Cycle Complete: Check that UFS closes when reservoir is full. If not, check FS. See "II.D.1. Float Switch Check."
- 8) **Freeze Cycle**—UFS closes and energizes WCR. WCR allows TDR to energize, then TDR energizes GM, FM, and CR. CR then energizes Comp. WV de-energizes. Ice production starts 4 to 6 minutes after Comp energizes depending on ambient and water conditions.
WCR Diagnosis: Confirm WCR energizes. If not, confirm UFS is closed. See "II.D.1. Float Switch Check." With UFS closed, check for 115VAC at WCR #8 (BK) to WCR #7 (W). If 115VAC is not present, check control switch position and continuity. Also check wire connections to FS and WCR. If 115VAC is present, check that WV de-energized. If not, check for 0VAC at WCR #2 (O) to neutral (W). If 115VAC is present, replace WCR. Next, check for 115VAC at WCR #5 (BR) to neutral (W) and WCR #3 (P) to neutral (W). If 115VAC is not present at WCR #5 (BR) to neutral (W), check control switch position and continuity. Also check wire connections to WCR. If 115VAC is present at WCR #5 (BR) to neutral (W) and not at WCR #3 (P) to neutral (W), WCR is not energized or contacts are sticking. Replace WCR. If 115VAC is present at WCR #3 (P) to neutral (W), WCR is good and TDR energizes. **TDR Diagnosis:** Confirm 115VAC at TDR #2 (BR) and TDR #5 (P) to TDR #3 (W). If 115VAC is present at TDR #2 (BR) and not at TDR #5 (P), see WCR Diagnosis above. If 115VAC is present at TDR #2 (BR) and TDR #5 (P) to TDR #3 (W) and GM does not start, check for 115VAC at TDR #8 (BR) and TDR #9 (W/R) to neutral (W). If 115VAC is present at TDR #8 (BR) and not at TDR #9 (W/R), replace TDR.

GM Diagnosis: Check that GM energizes. If not, check for 115VAC at GM. If 115VAC is not present, check GM external protector on front of control box. If tripped, reset.

If it does not reset, replace GM external protector. Once reset, if GM does not energize, check GM windings (internal protector) and GM capacitor. If GM starts but the auger does not turn, check coupling between auger and GM. **FM Diagnosis:** Check that FM energizes. If not, check for 115VAC at FM red (R) wire to neutral (W). If 115VAC is not present, check wiring connections from TDR and GM. If 115VAC is present and FM is not energized, check FM windings and fan blade for binding.

CR/Comp Diagnosis: Check for 115VAC at CR #8 (R) to neutral (W). If 115VAC is not present, check wiring connections from TDR and GM. If 115VAC is present, check for 115VAC at CR #3 (BR) and CR #5 (R) to neutral (W). If 115VAC is present on CR #3 (BR) and not at CR #5 (R), replace CR. If 115VAC is present at CR #5 (R), check Comp PTC and Comp winding.

- 9) **Refill/Low Water Safety**—As ice is produced, the water level in the reservoir drops. UFS opens, nothing happens at this time. LFS opens and refill begins, WCR de-energizes, TDR de-energizes, FT (90 sec.) starts, WV energizes. Comp, FM, and GM continue. LFS closes, nothing happens at this time. UFS closes, WCR energizes, TDR energizes, and FT resets. WV de-energizes. If FT terminates before UFS closes, Comp, CR, FM, and GM de-energize and WV remains energized until UFS closes.

Refill Diagnosis: Check that WCR de-energizes. If not, see "II.D.1. Float Switch Check." Once WCR de-energizes, confirm WV energizes. If not, check for 115VAC at WCR #2 (O) to neutral (W). If 115VAC is not present, replace WCR. If 115VAC is present, check WV solenoid continuity. Replace as needed. Confirm UFS closes and WCR energizes within 90 sec. of WV energizing. If not, confirm that water supply is on. Once UFS closes, WCR energizes, energizing TDR and resetting FT. If FT is exceeded, Comp, FM, and GM de-energize. Check that TDR energizes after WCR energizes. Check for 115VAC at TDR #5 (P) to neutral (W). If 115VAC is not present at TDR #5 (P) to neutral (W), confirm WCR status. If 115VAC is present at TDR #5 (P) to neutral (W), and Comp, CR, FM, and GM de-energized, replace TDR.

FT Diagnosis (90 sec. low water safety): If UFS does not close within 90 sec. of LFS opening, FT terminates and TDR de-energizes GM, FM, CR, and Comp. Components remain off until UFS closes. If components continue longer than 90 sec. with UFS open, replace TDR. If GM and FM de-energize but Comp continues, check CR contacts for sticking. Replace as needed.

- 10) **Shutdown (bin full)**—When the appliance is running, hold ice in contact with the thermostatic bulb. BC switch opens within 10 sec., shutting down the appliance. BC is factory set, and generally no adjustment is required. However, adjustment may be needed in some conditions, particularly at higher altitude locations. See "II.C. Bin Control Check."

Legend: **BC**—bin control; **Comp**—compressor; **CR**—compressor relay; **FM**—fan motor; **FS**—float switch; **FT**—fill timer; **GM**—gear motor; **LFS**—lower float switch; **PTC**—start relay; **ST**—shutdown timer; **TDR**—time delay relay; **UFS**—upper float switch; **WCR**—water control relay; **WV**—inlet water valve

C. Bin Control Check

BC shuts down the icemaker within 10 sec. when ice contacts the thermostatic bulb, regardless of the cycle at activation.

NOTICE

When the ambient temperature is below 45°F (7°C), BC opens and shuts down the appliance even if the ice storage bin is empty. When BC is set in the prohibited range, the appliance operates continuously even if the ice storage bin is filled with ice. Setting in the prohibited range may result in appliance and property damage.

BC is factory set, and generally no adjustment is required. However, adjustment may be needed in some conditions, particularly at higher altitude locations.

To check BC, follow the steps below.

- 1) Turn off the power supply.
- 2) Move the control switch to the "OFF" position.
- 3) Clear any ice away from BC bulb.
- 4) Remove the upper rear panel and disconnect BC wires from BC switch.
- 5) Hold your hand around the bulb to warm it up.
- 6) Check for continuity across BC switch. If closed, continue to step 8. If open, adjust or replace BC.
- 7) With the multimeter test leads still in place, hold ice on BC bulb to lower the temperature. Within 10 sec., BC switch should open. If it remains closed, adjust or replace BC.

Legend: **BC**—bin control

D. Float Switch Check and Cleaning

1. Float Switch Check

- 1) Move the control switch to the "DRAIN" position.
- 2) Remove the upper rear panel.
- 3) Allow the water system to drain for 1 min.
- 4) Move the control switch to the "OFF" position, then unplug the appliance from the electrical outlet.
- 5) Remove bell connectors from FS black (BK), blue (BU), and red (R) wires. Check continuity between black (BK) (common) and red (R) (UFS) and between black (BK) (common) and blue (BU) (LFS). If both are open, continue to step 6. If either are closed, follow the steps in "II.D.2. Float Switch Cleaning." After cleaning FS, check UFS and LFS again. Replace if necessary.
- 6) Cap the FS appliance wires. Black (BK), red (R), and blue (BU).
- 7) Plug the appliance into the electrical outlet, then move the control switch to the "ICE" position.
- 8) Once the reservoir overflows, move the control switch to the "OFF" position, then unplug the appliance from the electrical outlet.
- 9) Check continuity between black (BK) (common) and red (R) (UFS), and between black (BK) (common) and blue (BU) (LFS). If either are open, follow the steps in "II.D.2. Float Switch Cleaning." After cleaning FS, check UFS and LFS again. Replace if necessary.
- 10) Reconnect FS wires to the appropriate appliance wires. Black (BK) to black (BK), red (R) to brown (BR), and blue (BU) to blue (BU).
- 11) Replace upper rear panel in its correct position.
- 12) Plug the appliance into the electrical outlet, then move the control switch to the "ICE" position to start the automatic icemaking process.

Legend: **FS**—float switch; **LFS**—lower float switch; **UFS**—upper float switch

2. Float Switch Cleaning

Depending on local water conditions, scale may build up on FS. Scale on FS can cause inconsistent operation of UFS and LFS. In this case, FS should be cleaned and checked.

- 1) Move the control switch to the "OFF" position, then unplug the appliance from the electrical outlet.
- 2) Remove the upper rear panel.
- 3) Remove FS assembly from the reservoir cover.
- 4) Wipe down FS assembly with a mixture of 1 part Hoshizaki "Scale Away" and 25 parts warm water. Rinse the assembly thoroughly with clean water.
- 5) While not necessary, the floats can be removed from the shaft during cleaning. If you remove them, note that the blue float is on top (UFS) and the white float is on bottom (LFS). See Fig. 2. The floats must be installed with the magnets inside them towards the top of the switch. Installing the floats upside down will affect the timing of FS operation.

- 6) Rinse FS assembly thoroughly with clean water and replace in its correct position.
- 7) Replace the upper rear panel in its correct position.
- 8) Plug the appliance into the electrical outlet, then move the control switch to the "ICE" position to start the automatic icemaking process.

Legend: **FS**—float switch; **LFS**—lower float switch; **UFS**—upper float switch

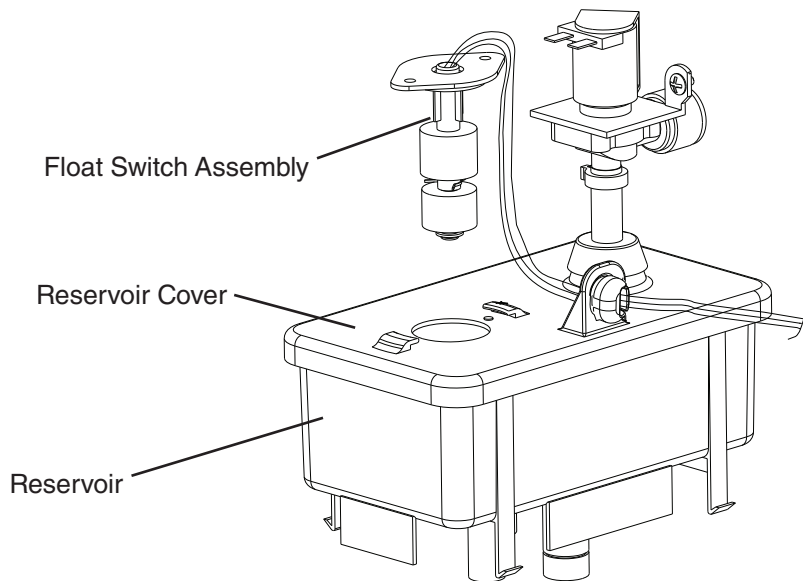

Fig. 1

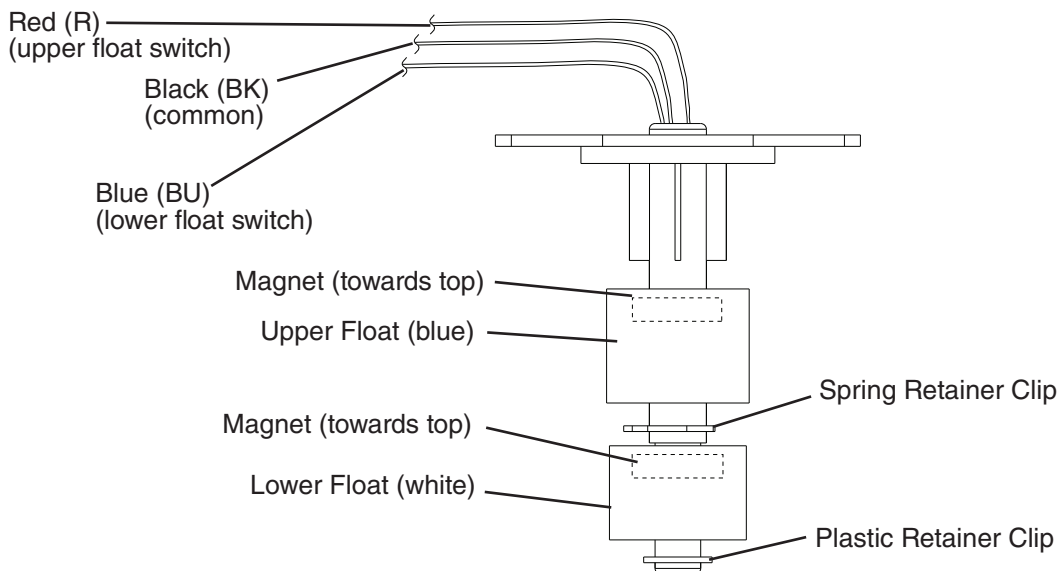

Fig. 2

E. Optional Drain Pump HS-5061

1. Overview

As ice melts, water drains from the storage bin into DP. LFS closes. Nothing happens at this time. UFS closes, DP energizes and pumps out the water. UFS opens, nothing happens at this time. LFS opens, DP de-energizes. If water cannot be pumped out of DP due to a blocked discharge hose, bad check valve, or bad DP motor, water level continues to rise and SFS closes. DP continues and appliance de-energizes. Power is supplied to DP motor as long as LFS is closed. For schematic, see "VIII.B.2. Optional Drain Pump HS-5061."

NOTICE

- If you remove DP from the appliance, be sure to follow all instructions below. Failure to do so may result in costly water damage.
- DP has an internal check valve. Do not install an external check valve.

Legend: **DP**—drain pump; **LFS**—lower float switch; **SFS**—safety float switch; **UFS**—upper float switch

2. Drain Pump Check

When the optional DP ([HS-5061](#)) is installed, test its operation at least twice a year as outlined below. Note that 115VAC is at DP even when the control switch is in the "OFF" position.

- 1) Move the control switch to the "OFF" position, then unplug the appliance from the electrical outlet. **WARNING! To reduce the risk of electric shock, do not touch the control switch or plug with damp hands.**
- 2) Remove all ice from the storage bin.
- 3) Plug the appliance back in.
- 4) Slowly pour 24 to 30 oz. (710 to 890 ml) of water over the storage bin drain hole in the storage bin.
- 5) If water pumps out properly and DP then de-energizes, proceed to step 6. If water does not pump out, confirm 115VAC to drain pump, replace as needed.
- 6) Move the control switch to the "ICE" position.
- 7) Pour another 24 to 30 oz. (710 to 890 ml) of water into the appliance's storage bin, then completely restrict the discharge hose while DP is operating. See Fig. 3. Pour more water into the appliance's storage bin until the appliance turns off. DP will continue to operate. Check for leaks.
- 8) Remove the discharge hose restriction and allow the water to be pumped out normally. Power returns to the appliance when SFS opens.
- 9) If the appliance fails to turn off with the discharge hose restricted or the pump fails to pump out the water, replace DP.

Legend: **DP**—drain pump; **SFS**—safety float switch

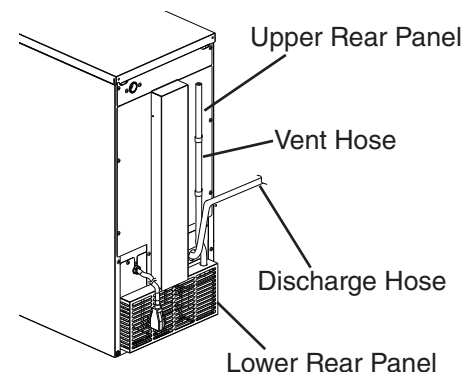

Fig. 3

F. Diagnostic Tables

1. No Ice Production

No Ice Production - Possible Cause	
Startup/Fill Cycle	
1. Power Supply	a) Unplugged, off, blown fuse, or tripped breaker. b) Not within specifications.
2. Optional Drain Pump HS-5061	a) Drain pump connection unplugged or loose. b) Drain pump safety float switch open.
3. Control Switch	a) "OFF" position. b) Bad contacts.
4. Bin Control Thermostat Assembly (with integrated heater)	a) Open with bin filled with ice. b) Out of position. c) Out of adjustment. See "II.C. Bin Control Check." d) Bad contacts. e) Bad thermostat heater.
5. Water Supply	a) Water supply off or improper water pressure. b) External water filters clogged.
6. Water Control Relay	a) Energized and not allowing water valve to energize. See "II.D.1. Float Switch Check." b) Defective.
7. Inlet Water Valve	a) Screen or orifice clogged. b) Defective.
8. Float Switch See "II.D. Float Switch Check and Cleaning."	a) Float does not move freely. b) Defective.
Freeze Cycle	
1. Water Control Relay	a) Defective.
2. Time Delay Relay	a) Defective.
3. Gear Motor	a) Gear motor external protector (2.4~3.0A) tripped. b) Gear motor internal protector open or windings open. c) Bad gear motor capacitor. d) Locked bearings. e) Spline coupling or gear broken and auger not turning.
4. Fan Motor	a) Fan blade does not move freely. b) Defective.
5. Compressor Relay	a) Defective.
6. Compressor	a) PTC relay defective b) Inefficient. c) Defective.
7. Evaporator	a) Dirty. b) Damaged or defective.
8. Condenser	a) Dirty.
9. Refrigerant	a) Low charge or overcharged. b) Refrigerant lines or components restricted.
10. Water System	a) Water leaks.

Refill	
1. Float Switch See "II.D. Float Switch Check and Cleaning."	a) Dirty/sticking.
	b) Defective.
2. Inlet Water Valve	a) Screen or orifice clogged.
	b) Defective.
3. Water Supply	a) Water supply off or improper water pressure (7 to 113 PSIG).
	b) External water filters clogged.
4. Water Control Relay	a) Defective.
5. Time Delay Relay	a) Defective.
Shutdown	
1. Bin Control Thermostat Assembly (with integrated heater)	a) Open with bin filled with ice.
	b) Out of position.
	c) Out of adjustment. See "II.C. Bin Control Check."
	d) Bad contacts.
	e) Bad thermostat heater.

III. Controls and Relays

The C-101BAH(-C) utilizes a control switch, time delay relay, water control relay, and compressor relay to control operation.

A. Control Switch

The control switch has 3 positions, "OFF," "ICE," and "DRAIN."

- a) "OFF": All components except the optional drain pump are de-energized when the control switch is in the "OFF" position. The optional drain pump circuit remains energized when the control switch is in the "OFF" position.
- b) "ICE": When placed in the "ICE" position, the inlet water valve energizes if upper float switch (UFS) is open. If upper float switch (UFS) is closed, gear motor and compressor energize.
- c) "DRAIN": When placed in the "DRAIN" position, drain valve energizes, draining the reservoir and evaporator.

B. Time Delay Relay

Time delay relay energizes once 115VAC is supplied to time delay relay #5 (P). Time delay relay contacts close between time delay relay #8 (BR) and time delay relay #9 (W/R), energizing the gear motor, fan motor, and compressor. When the lower float switch opens, the water control relay de-energizes, de-energizing the time delay relay. A 90 sec. low water safety timer starts. Once the upper float switch closes, the water control relay energizes, energizing the time delay relay. The time delay relay 90 sec. timer resets at this time. Once the 90 sec. low water safety timer is exceeded, gear motor, fan motor, and compressor de-energize.

C. Water Control Relay

The water control relay is controlled by the float switch. The water control relay energizes when the reservoir is full and the upper float switch closes. The water control relay de-energizes when the water in the reservoir lowers and the lower float switch opens. When energized, the time delay relay energizes and the inlet water valve de-energizes. When de-energized, the time delay relay de-energizes and the inlet water valve energizes.

IV. Refrigeration Circuit and Component Service Information

WARNING

- This appliance should be diagnosed and repaired only by qualified service personnel to reduce the risk of death, electric shock, serious injury, or fire.
- Move the control switch to the "OFF" position, then unplug the appliance from the electrical outlet before servicing.
- **CHOKING HAZARD:** Ensure all components, fasteners, and thumbscrews are securely in place after the appliance is serviced. Make sure that none have fallen into the storage bin.
- Make sure all food zones in the icemaker and storage bin are clean after service.

A. Refrigeration Circuit Service Information

WARNING

- Repairs requiring the refrigeration circuit to be opened must be performed by properly trained and EPA-certified service personnel.
- Use an electronic leak detector or soap bubbles to check for leaks. Add a trace of refrigerant to the system (if using an electronic leak detector), and then raise the pressure using nitrogen gas (140 PSIG). Do not use R-134a as a mixture with pressurized air for leak testing.

NOTICE

- Always recover the refrigerant and store it in an approved container. Do not discharge the refrigerant into the atmosphere.
- Do not leave the system open for longer than 15 min. when replacing or servicing parts. The Polyol Ester (POE) oils used in R-134a applications can absorb moisture quickly. Therefore it is important to prevent moisture from entering the system when replacing or servicing parts.
- Always install a new drier every time the sealed refrigeration system is opened. Do not replace the drier until after all other repair or replacement has been made. Install the new drier with the arrow on the drier in the direction of the refrigerant flow.
- When brazing, protect the drier by using a wet cloth to prevent the drier from overheating. Do not allow the drier to exceed 250°F (121°C).

1. Refrigerant Recovery

No refrigerant access valves are provided on this appliance. Using proper refrigerant practices, utilize a temporary tap-line valve on the high side to recover the refrigerant. Store the refrigerant in an approved container. Do not discharge the refrigerant into the atmosphere. After recovery is complete, replace the tap-line valve with a proper, permanent access valve.

2. Brazing

⚠ WARNING

- R-134a itself is not flammable at atmospheric pressure and temperatures up to 212°F (100°C).
- R-134a itself is not explosive or poisonous. However, when exposed to high temperatures (open flames), R-134a can be decomposed to form hydrofluoric acid and carbonyl fluoride both of which are hazardous.
- Do not use silver alloy or copper alloy containing arsenic.

- 1) Braze all fittings while purging with nitrogen gas flowing at a pressure of 3 to 4 PSIG.

NOTICE

- Always install a new drier every time the sealed refrigeration system is opened. Do not replace the drier until after all other repair or replacement has been made. Install the new drier with the arrow on the drier in the direction of the refrigerant flow.
- When brazing, protect the drier by using a wet cloth to prevent the drier from overheating. Do not allow the drier to exceed 250°F (121°C).

- 2) Use an electronic leak detector or soap bubbles to check for leaks. Add a trace of refrigerant to the system (if using an electronic leak detector), and then raise the pressure using nitrogen gas (140 PSIG). Do not use R-134a as a mixture with pressurized air for leak testing.

3. Evacuation and Recharge (R-134a)

- 1) Attach a vacuum pump to the system. Be sure the high-side charging hose is connected to the field-installed high-side access valve.

IMPORTANT

The vacuum level and vacuum pump may be the same as those for current refrigerants. However, the rubber hose and gauge manifold to be used for evacuation and refrigerant charge should be exclusively for POE oils.

- 2) Turn on the vacuum pump, then open the high-side valve on the gauge manifold. Never allow the oil in the vacuum pump to flow backwards.
- 3) Allow the vacuum pump to pull down to a 29.9" Hg vacuum. Evacuating period depends on pump capacity.
- 4) Close the high-side valve on the gauge manifold.
- 5) Disconnect the gauge manifold hose from the vacuum pump and attach it to a refrigerant service cylinder. Remember to loosen the connection and purge the air from the hose. For the required refrigerant charge, see the nameplate. Hoshizaki recommends only virgin refrigerant or reclaimed refrigerant which meets ARI Standard 700 (latest edition) be used.

- 6) A liquid charge is required when charging an R-134a system. Place the service cylinder on the scales; if the service cylinder is not equipped with a dip tube, invert the service cylinder, then place it on the scales. Open the high-side valve on the gauge manifold.
- 7) Allow the system to charge with liquid until the proper charge weight is met.
- 8) Close the high-side valve on the gauge manifold, then close the refrigerant access valve (if applicable). Disconnect the gauge manifold hose.
- 9) Cap the refrigerant access valve to prevent a possible leak.

B. Component Service Information

NOTICE

- When replacing a component listed below, see the notes to help ensure proper operation.
- When replacing evaporator assembly and water circuit components, make sure there are no water leaks after the repair is complete.

Component	Notes
Extruding Head	<ul style="list-style-type: none"> • Seal bolts must be replaced once removed because seal material is one-time use only. • If new seal bolts do not have preapplied threadlocker, apply Loctite 243 or equivalent threadlocker to seal bolt threads. • Tighten down the new seal bolts to a torque of 11.1 ft-lb/15 N-m.
Compressor	<ul style="list-style-type: none"> • Install a new drier and PTC relay.
Upper and Lower Bearings	<ul style="list-style-type: none"> • Inspect the upper bearing for wear. See "IV.B.1. Upper Bearing Wear Check." Replace if necessary. • When replacing the upper bearing it is advised to also change the lower bearing at the same time.
Evaporator	<ul style="list-style-type: none"> • Install a new drier. • Inspect the mechanical seal and O-ring prior to installing the new evaporator. If worn, cracked, or scratched, the mechanical seal should also be replaced.
Gear Motor	<ul style="list-style-type: none"> • Install a new gear motor capacitor.

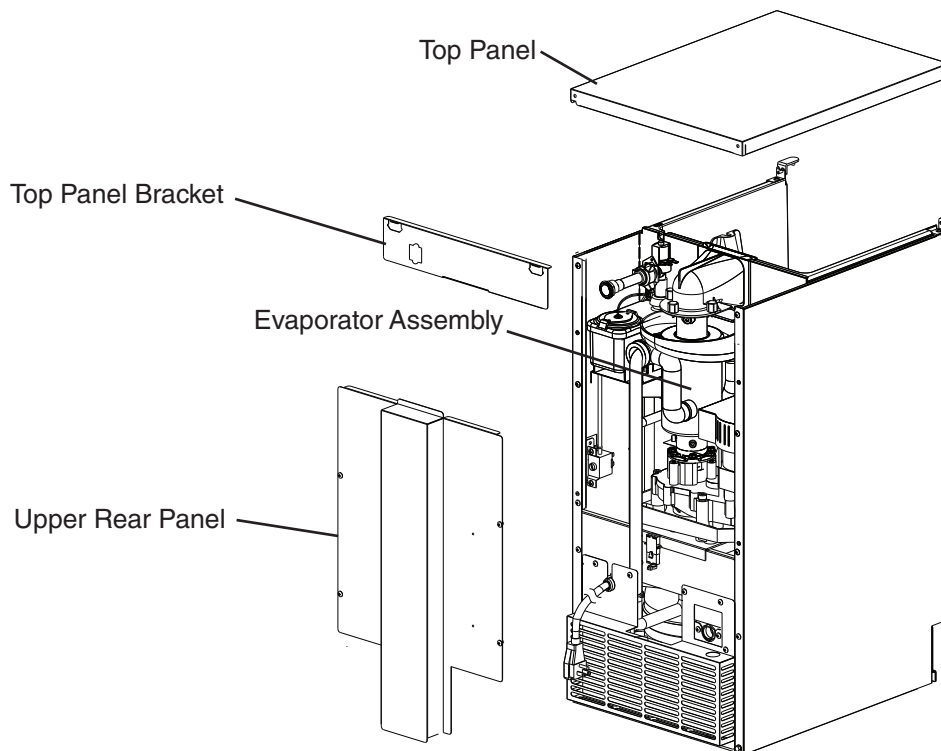

Fig. 4

C-101BAH-AD Shown

Evaporator Assembly

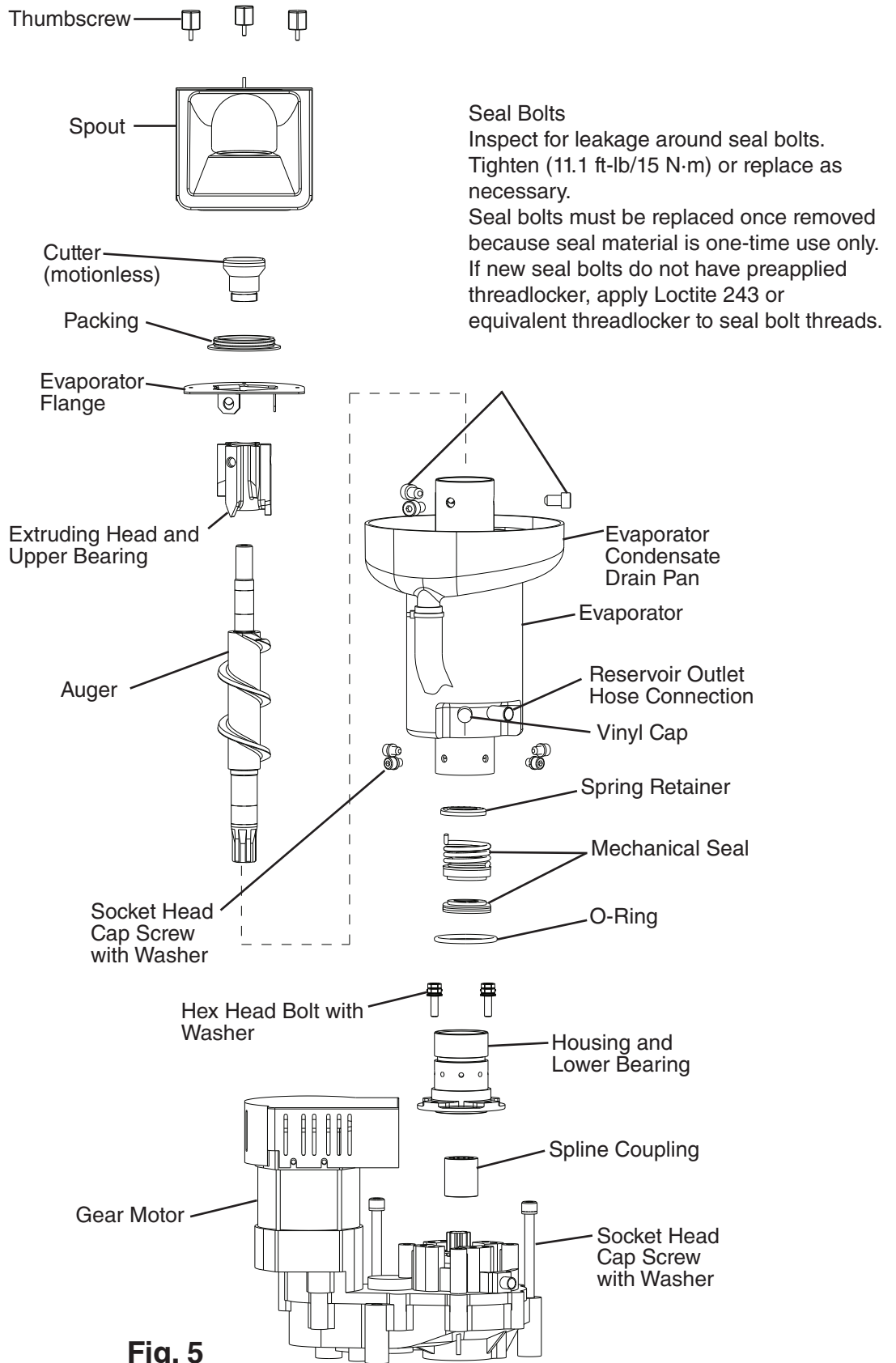

Fig. 5

1. Upper Bearing Wear Check

To ensure that the bearing inside the extruding head does not exceed the wear tolerance of .02", follow the instructions below.

- 1) Move the control switch to the "OFF" position, then unplug the appliance from the electrical outlet.
- 2) Remove all ice from the storage bin.
- 3) Remove the top panel. See Fig. 4.
- 4) Remove the spout and packing.
- 5) Remove the cutter.
- 6) Grasp the top of the auger and move the auger towards you and then try to insert a .02" round stock or pin gauge in between the back side of the auger shaft and the bearing surface. See Fig. 6. Check several locations around the auger shaft. If the gauge goes between the shaft and the bearing at any point or if the bearing is scratched or cracked, both the top bearing in the extruding head and the lower bearing in the housing should be replaced. Instructions for removing the extruding head and housing are located later in this procedure.
Note: Replacing the bearing requires a bearing press adaptor. If one is not available, replace the entire extruding head and housing.
- 7) Replace the removed parts and panel in the reverse order of which they were removed.
- 8) Plug the appliance into the electrical outlet, then move the control switch to the "ICE" position to start the automatic icemaking process.

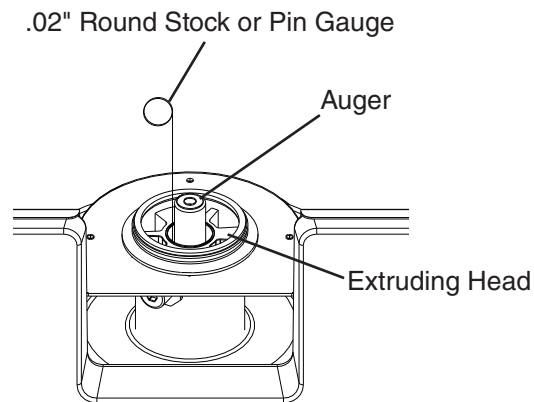

Fig. 6

2. Removal and Replacement of Extruding Head

- 1) Close the water supply line shut-off valve.
- 2) Move the control switch to the "DRAIN" position.
- 3) Allow the water system to drain for 1 minute.
- 4) Remove all ice from the storage bin.
- 5) After all of the water has drained, move the control switch to the "OFF" position. Unplug the appliance from the electrical outlet.
- 6) Remove the top panel. See Fig. 4.
- 7) Remove the spout and packing.
- 8) Loosen the cutter (do not remove).
- 9) Remove the seal bolts securing the extruding head and evaporator flange, then grasp the cutter and lift off. **NOTICE! Discard existing seal bolts after removal. Seal bolts must be replaced once removed because seal material is one-time use only.**
- 10) Remove the cutter from the old extruding head and place it on the new extruding head.
- 11) Place and align the new extruding head and evaporator flange. See Fig. 7.

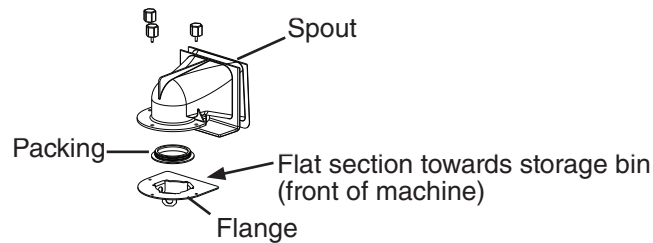

Fig. 7

- 12) If new seal bolts do not have preapplied threadlocker, apply Loctite 243 or equivalent threadlocker to seal bolts. Tighten new seal bolts to a torque of 11.1 ft-lb/15 N·m.
- 13) Tighten down the cutter.
- 14) Secure the packing and spout in their correct positions.
- 15) Open the water supply line shut-off valve.
- 16) Plug the appliance into the electrical outlet, then move the control switch to the "ICE" position to start the automatic icemaking process.
- 17) Once the appliance starts to produce ice, allow it to run for another 30 minutes. Check for water leaks.
- 18) After 30 minutes, move the control switch to the "OFF" position. Unplug the appliance from the electrical outlet.
- 19) Pour warm water into the storage bin and melt the ice. Clean the storage bin liner using a neutral cleaner. Rinse thoroughly after cleaning.
- 20) Replace the top panel in its correct position.
- 21) Plug the appliance into the electrical outlet, then move the control switch to the "ICE" position to start the automatic icemaking process.

3. Removal and Replacement of Auger

- 1) Close the water supply line shut-off valve.
- 2) Move the control switch to the "DRAIN" position.
- 3) Allow the water system to drain for 1 minute.
- 4) After all of the water has drained, move the control switch to the "OFF" position. Unplug the appliance from the electrical outlet.
- 5) Remove all ice from the storage bin.
- 6) Remove the top panel. See Fig. 4.
- 7) Remove the spout and packing.
- 8) Remove the seal bolts securing the extruding head and evaporator flange, then grasp the cutter and lift off. **NOTICE! Discard existing seal bolts after removal. Seal bolts must be replaced once removed because seal material is one-time use only.**
- 9) Grasp the auger and carefully lift out.
- 10) When pulling out the auger, the upper part of the mechanical seal should come out with it. The mechanical seal consists of two parts. One moves along with the auger, and the other is fixed on the lower housing. Inspect the part of the mechanical seal that came out with the auger. If the contact surface on the bottom of the seal is worn, cracked or scratched, the mechanical seal may cause water leaks and both the upper and lower parts of the mechanical seal should be replaced. Instructions for removing the mechanical seal are located later in this procedure.
- 11) Remove the mechanical seal from the old auger and place it on the new auger.
- 12) Install the new auger.
- 13) Replace the extruding head (with cutter), and evaporator flange in their correct positions. Confirm the cutter is tight. See Fig. 7.
- 14) If new seal bolts do not have preapplied threadlocker, apply Loctite 243 or equivalent threadlocker to seal bolts. Tighten to a torque of 11.1 ft-lb/15 N·m.
- 15) Replace the packing and spout in their correct positions.
- 16) Open the water supply line shut-off valve.
- 17) Plug the appliance into the electrical outlet, then move the control switch to the "ICE" position to start the automatic icemaking process.
- 18) Once the appliance starts to produce ice, allow it to run for another 30 minutes. Check for water leaks.
- 19) After 30 minutes, move the control switch to the "OFF" position. Unplug the appliance from the electrical outlet.
- 20) Pour warm water into the storage bin and melt the ice. Clean the storage bin liner using a neutral cleaner. Rinse thoroughly after cleaning.
- 21) Replace the top panel in its correct position.
- 22) Plug the appliance into the electrical outlet, then move the control switch to the "ICE" position to start the automatic icemaking process.

4. Removal and Replacement of Evaporator

NOTICE

- Always install a new drier every time the sealed refrigeration system is opened. Do not replace the drier until after all other repair or replacement has been made.
- When brazing, protect the drier by using a wet cloth to prevent the drier from overheating. Do not allow the drier to exceed 250°F (121°C).

- 1) Close the water supply line shut-off valve.
- 2) Move the control switch to the "DRAIN" position.
- 3) Allow the water system to drain for 1 minute.
- 4) After all of the water has drained, move the control switch to the "OFF" position. Unplug the appliance from the electrical outlet.
- 5) Remove all ice from the storage bin.
- 6) Remove the top panel and rear panels. See Fig. 4.
- 7) Remove the spout and packing.
- 8) Remove the seal bolts securing the extruding head and evaporator flange.
NOTICE! Discard existing seal bolts after removal. Seal bolts must be replaced once removed because seal material is one-time use only.
- 9) Grasp the cutter and carefully lift out the extruding head and auger. When pulling out the auger, the upper part of the mechanical seal should come out with it.
- 10) Disconnect the reservoir outlet hose from the evaporator.
- 11) Remove the evaporator condensate drain pan.
- 12) Install a temporary tap-line valve on the high side, then recover the refrigerant and store it in an approved container.
- 13) Disconnect the inlet and outlet tubing.
- 14) Remove the socket head cap screws securing the evaporator to the lower housing.
- 15) Lift off the evaporator.
- 16) Inspect the mechanical seal and O-ring prior to installing the new evaporator. The mechanical seal consists of two parts. One moves along with the auger, and the other is fixed on the lower housing. If the contact surfaces of these two parts are worn, cracked or scratched, the mechanical seal may cause water leaks and should be replaced. Instructions for removing the mechanical seal and lower housing are located later in this procedure.
- 17) Make sure the lower mechanical seal and the O-ring are in place, then place the evaporator assembly in position. Secure the evaporator to the lower housing using the socket head cap screws.
- 18) Replace the tap-line valve with a proper, permanent access valve.
- 19) Remove the drier, then place the new drier in position.
- 20) Braze all fittings while purging with nitrogen gas flowing at a pressure of 3 to 4 PSIG.

- 21) Use an electronic leak detector or soap bubbles to check for leaks. Add a trace of refrigerant to the system (if using an electronic leak detector), and then raise the pressure using nitrogen gas (140 PSIG). Do not use R-134a as a mixture with pressurized air for leak testing.
- 22) Evacuate the system, then charge it with refrigerant. See the nameplate for the required refrigerant charge.
- 23) Reattach and secure the reservoir outlet hose. Replace the evaporator condensate drain pan and all hoses in their correct positions.
- 24) Install the auger assembly with the upper part of the mechanical seal attached. Replace the cutter, extruding head, and evaporator flange in their correct positions and align the extruding head and evaporator flange holes. See Fig. 7.
- 25) If new seal bolts do not have preapplied threadlocker, apply Loctite 243 or equivalent threadlocker to seal bolts. Tighten seal bolts to a torque of 11.1 ft-lb/15 N·m.
- 26) Replace the packing and spout in their correct positions.
- 27) Open the water supply line shut-off valve.
- 28) Plug the appliance into the electrical outlet, then move the control switch to the "ICE" position to start the automatic icemaking process.
- 29) Once the appliance starts to produce ice, allow it to run for another 30 minutes. Check for water leaks.
- 30) After 30 minutes, move the control switch to the "OFF" position. Unplug the appliance from the electrical outlet.
- 31) Pour warm water into the storage bin and melt the ice. Clean the storage bin liner using a neutral cleaner. Rinse thoroughly after cleaning.
- 32) Replace the rear panels and top panel in their correct positions.
- 33) Plug the appliance into the electrical outlet, then move the control switch to the "ICE" position to start the automatic icemaking process.

5. Removal and Replacement of Mechanical Seal and Lower Housing

5a. Mechanical Seal

- 1) Close the water supply line shut-off valve.
- 2) Move the control switch to the "DRAIN" position.
- 3) Allow the water system to drain for 1 minute.
- 4) After all of the water has drained, move the control switch to the "OFF" position. Unplug the appliance from the electrical outlet.
- 5) Remove all ice from the storage bin.
- 6) Remove the top panel and upper rear panel. See Fig. 4.
- 7) Remove the spout and packing.
- 8) Remove the seal bolts securing the extruding head and evaporator flange.
NOTICE! Discard existing seal bolts after removal. Seal bolts must be replaced once removed because seal material is one-time use only.

- 9) Grasp the cutter and carefully lift out the extruding head.
- 10) Grasp the auger and carefully lift it out. When pulling out the auger, the upper part of the mechanical seal should come out with it.
- 11) Remove the socket head cap screws securing the evaporator to the lower housing.
- 12) Raise the evaporator up to access the lower housing.
- 13) The mechanical seal consists of two parts. One moves along with the auger, and the other is fixed on the lower housing. If the contact surfaces of these two parts are worn, cracked or scratched, the mechanical seal may cause water leaks and should be replaced.
- 14) Remove the mechanical seal from the housing. If only replacing the mechanical seal, proceed to step 17. **NOTICE! To help prevent water leaks, be careful not to damage the surfaces of the O-ring or mechanical seal.**

5b. Lower Housing

- 15) Remove the O-ring and the bolts securing the lower housing to the gear motor and remove the housing from the gear motor. If inspection of the upper bearing inside the extruding head (see "IV.B.1. Upper Bearing Wear Check") indicates that it is out of tolerance, replace both it and the bearing inside the lower housing.
Note: Replacing the bearing requires a bearing press adaptor. If one is not available, replace the entire extruding head and housing.
- 16) Mount the lower housing onto the gear motor, then install the O-ring onto the lower housing.
- 17) Install the lower part of the mechanical seal onto the lower housing.
- 18) Lower the evaporator down and secure it to the lower housing.
- 19) Install the auger assembly with the upper part of the mechanical seal attached. Replace the cutter, extruding head, and evaporator flange in their correct positions. Align the evaporator flange holes with the extruding head holes. See Fig. 7.
- 20) If new seal bolts do not have preapplied threadlocker, apply Loctite 243 or equivalent threadlocker to seal bolts. Tighten new seal bolts to a torque of 11.1 ft-lb/15 N·m.
- 21) Tighten the cutter on the auger.
- 22) Replace the packing and spout in their correct positions.
- 23) Open the water supply line shut-off valve.
- 24) Plug the appliance into the electrical outlet, then move the control switch to the "ICE" position to start the automatic icemaking process.
- 25) Once the appliance starts to produce ice, allow it to run for another 30 minutes. Check for water leaks.
- 26) After 30 minutes, move the control switch to the "OFF" position. Unplug the appliance from the electrical outlet.
- 27) Pour warm water into the storage bin and melt the ice. Clean the storage bin liner using a neutral cleaner. Rinse thoroughly after cleaning.

- 28) Replace the upper rear panel and top panel in their correct positions.
- 29) Plug the appliance into the electrical outlet, then move the control switch to the "ICE" position to start the automatic icemaking process.

6. Removal and Replacement of Gear Motor

NOTICE! Hoshizaki recommends that the gear motor capacitor be replaced at the same time as the gear motor.

- 1) Close the water supply line shut-off valve.
- 2) Move the control switch to the "DRAIN" position.
- 3) Allow the water system to drain for 1 minute.
- 4) After all of the water has drained, move the control switch to the "OFF" position, then unplug the appliance from the electrical outlet.
- 5) Remove all ice from the storage bin.
- 6) Remove the top panel and upper rear panel. See Fig. 4.
- 7) Remove the bolts securing the lower housing to the gear motor. Lift the evaporator up slightly.
- 8) Remove the bolts securing the gear motor.
- 9) Disconnect the gear motor wires, then remove the gear motor.
- 10) Attach the spline coupling from the old gear motor to the new gear motor.
- 11) Install the new gear motor.
- 12) Lower the evaporator onto the gear motor. Secure the lower housing to the gear motor.
- 13) Reconnect the electrical wires.
- 14) Open the water supply line shut-off valve.
- 15) Plug the appliance into the electrical outlet, then move the control switch to the "ICE" position to start the automatic icemaking process.
- 16) Once the appliance starts to produce ice, check for water leaks.
- 17) Move the control switch to the "OFF" position, then unplug the appliance from the electrical outlet.
- 18) Pour warm water into the storage bin and melt the ice. Clean the storage bin liner using a neutral cleaner. Rinse thoroughly after cleaning.
- 19) Replace the upper rear panel and top panel in their correct positions.
- 20) Plug the appliance into the electrical outlet, then move the control switch to the "ICE" position to start the automatic icemaking process.

V. Maintenance

The appliance must be maintained in accordance with the instruction manual and labels provided. Consult with your local Hoshizaki Certified Service Representative about maintenance service.

WARNING

- Only qualified service technicians should service the appliance.
- To reduce the risk of electric shock, do not touch the control switch with damp hands.
- **Before Servicing:** Move the control switch to the "OFF" position. Unplug the appliance from the electrical outlet to prevent the power supply from being turned back on inadvertently.
- **CHOKING HAZARD:** Ensure all components, fasteners, and thumbscrews are securely in place after any maintenance is done to the appliance. Make sure that none have fallen into the storage bin.
- Do not place fingers or any other objects into the ice discharge opening.
- After service, make sure that there are no wires pinched between the panels and appliance. Make sure you do not damage or pinch the water supply line, drain line, or power cord.

A. Maintenance Schedule

The maintenance schedule below is a guideline. More frequent maintenance may be required depending on water quality, the appliance's environment, and local sanitation regulations.

Maintenance Schedule		
Frequency	Area	Task
Weekly	Scoop	Clean the scoop using a neutral cleaner. Rinse thoroughly after cleaning.
Monthly	Drain the Appliance	Move the control switch to the "DRAIN" position. Allow the water system to drain for 1 minute. Clear ice away from the bin control bulb. Move the control switch to the "ICE" position. After the gear motor starts, move the control switch to the "DRAIN" position. Allow the water system to drain for 1 minute. Move the control switch to the "ICE" position to start the automatic icemaking process.
	Appliance Exterior	Wipe down with a clean, soft cloth. Use a damp cloth containing a neutral cleaner to wipe off oil or dirt build up. Clean any chlorine staining (rust colored spots) using a non-abrasive cleanser.
Every 3 Months	Storage Bin Drain	Maintain as outlined in the instruction manual.
Every 6 Months	Icemaker and Storage Bin	Clean and sanitize per the cleaning and sanitizing instructions provided in the instruction manual.
	Evaporator Condensate Drain Pan and Gear Motor Drain Pan	Wipe down with clean cloth and warm water.
	Extruding Head Seal Bolts	Inspect for leakage around seal bolts. Tighten (see torque value below) or replace as necessary. Seal bolts must be replaced once removed because seal material is one-time use only. If new seal bolts do not have preapplied threadlocker, apply Loctite 243 or equivalent threadlocker to seal bolt threads.
		Torque: 11.1 ft-lb/15 N·m
	Optional Drain Pump (HS-5061)	Test as outlined in "II.E. Optional Drain Pump HS-5061 ."
	External Water Filters	Check for proper pressure and change if necessary.
Yearly	Water Supply Inlet	Close the water supply line shut-off valve and drain the water system. Clean the water supply inlet screen.
	Condenser	Inspect. Clean if necessary.
	Water Hoses	Inspect the water hoses and clean/replace if necessary.
	Upper Bearing (extruding head)	Check for wear using .02" round stock or pin gauge. Replace both upper bearing and lower bearing if wear exceeds factory recommendations. See "IV.B.1. Upper Bearing Wear Check."
After 3 Years, then Yearly	Upper Bearing (extruding head); Lower Bearing and O-Ring (lower housing); Mechanical Seal; Evaporator Cylinder; Auger	Inspect. Replace both upper bearing and lower bearing if wear exceeds factory recommendations. Replace the mechanical seal if the seal's contact surfaces are worn, cracked, or scratched.

VI. Preparing the Appliance for Periods of Non-Use

During extended periods of non-use, extended absences, or in sub-freezing temperatures, follow the instructions below. When the appliance is not used for two or three days under normal conditions, it is sufficient to move the control switch to the "OFF" position.

⚠ WARNING

Only qualified service technicians should service the appliance.

NOTICE

During extended periods of non-use, extended absences, or in sub-freezing temperatures, follow the instructions below to reduce the risk of costly water damage.

- 1) Move the control switch to the "OFF" position. **WARNING! To reduce the risk of electric shock, do not touch the control switch or plug with damp hands.**
- 2) Close the water supply line shut-off valve, then open the water supply line drain valve.
- 3) Allow the line to drain by gravity.
- 4) Move the control switch to the "DRAIN" position.
- 5) Allow the water system to drain for 1 min.
- 6) Attach a compressed air or carbon dioxide supply to the water supply line drain valve.
- 7) Move the control switch to the "ICE" position.
- 8) Blow the water supply line out using the compressed air or carbon dioxide supply.
- 9) Close the water supply line drain valve.
- 10) Move the control switch to the "OFF" position, then unplug the appliance from the electrical outlet.
- 11) Remove the screws securing the upper rear panel, then remove it. See Fig. 8.
- 12) Remove the clamp securing the reservoir outlet hose to the reservoir. Disconnect the reservoir outlet hose from the reservoir.
- 13) Attach a compressed air or carbon dioxide supply to the reservoir outlet hose.

Fig. 8

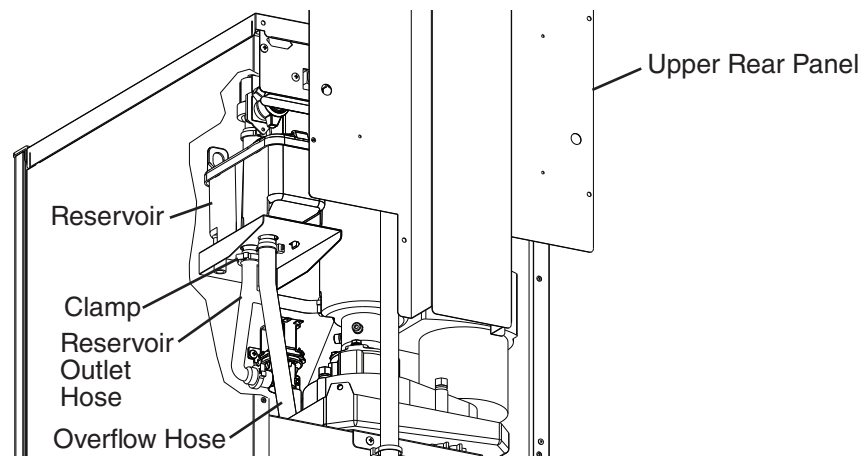

- 14) Plug the appliance back in, then move the control switch to the "DRAIN" position.
- 15) Blow out the reservoir outlet hose using the compressed air or carbon dioxide supply.
- 16) Move the control switch to the "OFF" position, then unplug the appliance from the electrical outlet.
- 17) Reconnect the reservoir outlet hose to the reservoir, then secure with the clamp. Make sure all hoses are connected and secure.
- 18) Replace the rear panel in its correct position.
- 19) Clean the storage bin by using a neutral cleaner. Rinse thoroughly after cleaning.

VII. Disposal

The appliance contains refrigerant and must be disposed of in accordance with applicable national, state, and local codes and regulations. Refrigerant must be recovered by properly certified service personnel.

VIII. Technical Information

A. Specification and Performance Data

1. C-101BAH(-DS)(-AD)(-ADDS)

SPECIFICATION SHEET

AC SUPPLY VOLTAGE	115/60/1	
AMPERAGE	4.0 A	
MINIMUM CIRCUIT AMPACITY	15 A	
MAXIMUM FUSE SIZE	15 A	
ELECTRIC & WATER CONSUMPTION	90/70°F	70/50°F
ELECTRIC W (kWH/100 lbs.)	310 (12.1)	297 (7.7)
WATER gal./24HR (gal./100 lbs.)	7.7 (12)	11.1 (12)
SHAPE OF ICE	Cubelet	
ICE QUALITY	Approx. 81.6%	
APPROXIMATE STORAGE CAPACITY	29 lbs. (13 kg) [Bin Control Setting 22 lbs. (10.0 kg)]	
REFRIGERANT CHARGE	R134a 3.17 oz. (90 g)	

PERFORMANCE DATA

APPROXIMATE ICE PRODUCTION PER 24 HR.	AMBIENT TEMP. (°F/°C)	WATER TEMP. (°F/°C)					
		50/10		70/21		90/32	
	70/21	92	<u>42</u>	89	<u>40</u>	84	<u>38</u>
	80/27	81	<u>37</u>	71	<u>32</u>	66	<u>30</u>
	90/32	66	<u>30</u>	62	<u>28</u>	57	<u>26</u>
lbs./day kg./day	100/38	55	<u>25</u>	54	<u>24</u>	49	<u>22</u>
APPROXIMATE ELECTRIC CONSUMPTION	70/21	297		308		309	
	80/27	310		310		312	
	90/32	313		310		316	
	watts	100/38	316		316		316
APPROXIMATE WATER CONSUMPTION PER 24 HR.	70/21	11	<u>0.04</u>	11	<u>0.04</u>	10	<u>0.04</u>
	80/27	10	<u>0.04</u>	9	<u>0.03</u>	8	<u>0.03</u>
	90/32	8	<u>0.03</u>	8	<u>0.03</u>	7	<u>0.08</u>
	gal./day m ³ /day	100/38	7	<u>0.03</u>	6	<u>0.02</u>	6
Evaporator Outlet	70/21	-5		-5		-5	
	80/27	-5		-2		-2	
	90/32	-2		-2		1	
	100/38	1		1		1	
HEAD PRESSURE	70/21	115	<u>8.1</u>	165	<u>11.6</u>	183	<u>12.9</u>
	80/27	115	<u>8.1</u>	165	<u>11.6</u>	183	<u>12.9</u>
	90/32	115	<u>8.1</u>	165	<u>11.6</u>	183	<u>12.9</u>
	PSIG kg/cm ² G	100/38	115	<u>8.1</u>	165	<u>11.6</u>	183
SUCTION PRESSURE	70/21	12	<u>0.8</u>	17	<u>1.2</u>	19	<u>1.3</u>
	80/27	12	<u>0.8</u>	17	<u>1.2</u>	19	<u>1.3</u>
	90/32	12	<u>0.8</u>	17	<u>1.2</u>	19	<u>1.3</u>
	PSIG kg/cm ² G	100/38	12	<u>0.8</u>	17	<u>1.2</u>	19

TOTAL HEAT OF REJECTION FROM CONDENSER 1850 BTU/h [AT 90°F (32°C) / WT 70°F (21°C)]

B. Wiring Diagrams

1. C-101BAH(-DS)(-AD)(-ADDS)

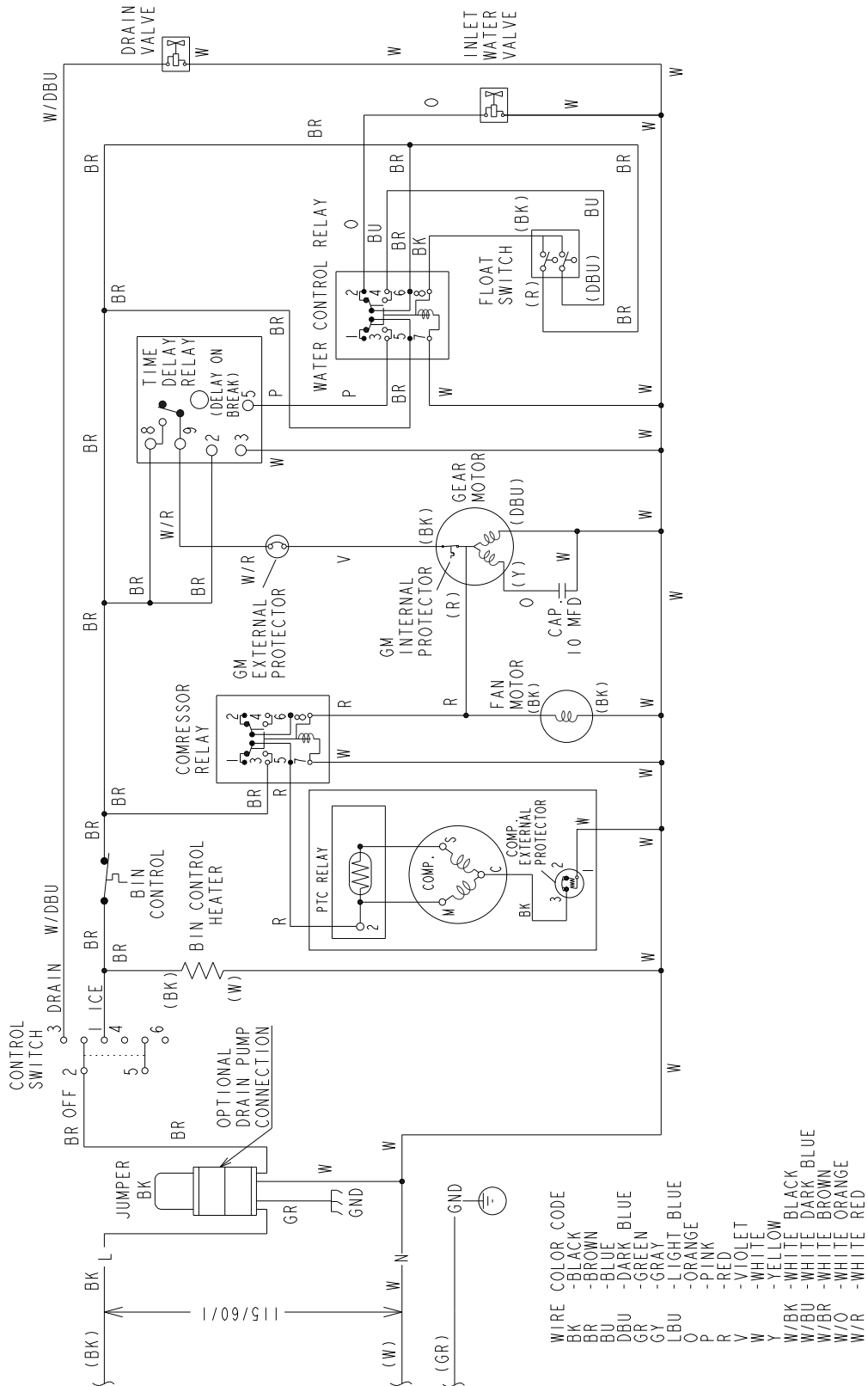

2. Optional Drain Pump HS-5061

