



HOSHIZAKI

Instruction Manual

Commercial Series
Refrigerated Kitchen Equipment

Models
Reach-In S-Series



hoshizakiamerica.com

Issued: 5-17-2016
Revised: 7-19-2016

⚠ WARNING

Only qualified service technicians should install and service the appliance. To obtain the name and phone number of your local Hoshizaki Certified Service Representative, visit www.hoshizaki.com. No installation or service should be undertaken until the technician has thoroughly read this Instruction Manual. Likewise, the owner/manager should not proceed to operate the appliance until the installer has instructed them on its proper operation. Failure to install, operate, and maintain the appliance in accordance with this manual may adversely affect safety, performance, component life, and warranty coverage. Proper installation is the responsibility of the installer. Product failure or property damage due to improper installation is not covered under warranty.

Hoshizaki provides this manual primarily to assist qualified service technicians in the installation, maintenance, and service of the appliance.

Should the reader have any questions or concerns which have not been satisfactorily addressed, please call, send an e-mail message, or write to the Hoshizaki Technical Support Department for assistance.

Phone: 1-800-233-1940; (770) 487-2331

Fax: 1-800-843-1056; (770) 487-3360

E-mail: techsupport@hoshizaki.com

HOSHIZAKI AMERICA, INC.

618 Highway 74 South

Peachtree City, GA 30269

Attn: Hoshizaki Technical Support Department

Web Site: www.hoshizaki.com

NOTE: To expedite assistance, all correspondence/communication **MUST** include the following information:

- Model Number _____
- Serial Number _____
- Complete and detailed explanation of the problem.

IMPORTANT

This manual should be read carefully before the appliance is installed and operated. Read the warnings and guidelines contained in this booklet carefully as they provide essential information for the continued safe use and maintenance of the appliance. Retain this booklet for any further reference that may be necessary.

CONTENTS

Important Safety Information	4
I. Installation Instructions	7
A. Location	7
B. Checks Before Installation.....	7
C. Setup.....	8
D. Door Reversal.....	9
E. Unit Leveling	9
F. Electrical Connection	10
G. Final Checklist	11
II. Operating Instructions.....	12
A. Important Notes About Usage	12
B. Startup	13
C. Controls and Adjustments	14
1. Temperature Display.....	14
2. Adjusting the Temperature Setpoint.....	14
3. Changing the Temperature Display Scale (°F or °C)	15
4. Light Switch for Glass Door Models.....	15
D. Control Module Icons	15
E. Defrost.....	16
F. Food Storage	16
G. Alarm Safeties.....	17
H. Safety Devices	18
I. Cooling Performance	18
J. Cabinet Condensation	18
III. Cleaning and Maintenance Instructions.....	19
A. Cleaning	19
1. Exterior.....	19
2. Cabinet Interior	19
3. Door Gaskets.....	19
4. Shelves	19
5. Glass Door.....	19
B. Maintenance/Troubleshooting	20
1. Condenser.....	20
2. Condensate Drain Boot	20
3. Power Supply Connection.....	21
IV. Preparing the Appliance for Periods of Non-Use	22
V. Disposal	23

Important Safety Information

Throughout this manual, notices appear to bring your attention to situations which could result in death, serious injury, damage to the appliance, or damage to property.

⚠ WARNING Indicates a hazardous situation which could result in death or serious injury.

NOTICE Indicates a situation which could result in damage to the appliance or property.

IMPORTANT Indicates important information about the use and care of the appliance.

⚠ WARNING

This appliance should be destined only to the use for which it has been expressly conceived. Any other use should be considered improper and therefore dangerous. The manufacturer cannot be held responsible for injury or damage resulting from improper, incorrect, and unreasonable use. Failure to install, operate, and maintain the appliance in accordance with this manual will adversely affect safety, performance, component life, and warranty coverage.

To reduce the risk of death, electric shock, serious injury, or fire, follow basic precautions including the following:

- Only qualified service technicians should install and service this appliance.
- This appliance must be installed in accordance with applicable national, state, and local codes and regulations.
- To reduce the risk of electric shock, do not touch the power switch or plug with damp hands.
- Make sure the power switch is in the "OFF" position before plugging in or unplugging the appliance to reduce the risk of electric shock.
- Before servicing, move the power switch to the "OFF" position. Unplug the appliance from the electrical outlet.
- This appliance requires an independent power supply of proper capacity. See the nameplate for electrical specifications. Failure to use an independent power supply of proper capacity can result in a tripped breaker, blown fuse, damage to existing wiring, or component failure. This could lead to heat generation or fire.
- **115VAC Models: THIS APPLIANCE MUST BE GROUNDED:** This appliance is equipped with a NEMA 5-15 three-prong grounding plug  to reduce the risk of potential shock hazards. It must be plugged into a properly grounded, independent 3-prong wall outlet. If the outlet is a 2-prong outlet, it is your personal responsibility to have a qualified electrician replace it with a properly grounded, independent 3-prong wall outlet. Do not remove the ground prong from the plug and do not use an adapter plug. Failure to follow these instructions may result in death, electric shock, or fire.

⚠ WARNING, continued

- **208-230VAC Models: THIS APPLIANCE MUST BE GROUNDED:** This appliance is equipped with a NEMA L14-20 four-prong locking, grounding plug  to reduce the risk of potential shock hazards. It must be plugged into a properly grounded, independent 4-prong wall outlet. If the outlet is a 3-prong outlet or a 4-prong non-locking outlet, it is your personal responsibility to have a qualified electrician replace it with a properly grounded, independent 4-prong locking wall outlet. Do not remove the ground prong from the plug and do not use an adapter plug. After plugging in, twist the plug clockwise to lock it into place. Failure to follow these instructions may result in death, electric shock, or fire.
- Do not use an extension cord.
- Do not use an appliance with a damaged power cord. The power cord should not be altered, jerked, bundled, weighed down, pinched, or tangled. Such actions could result in electric shock or fire. To unplug the appliance, be sure to pull the plug, not the cord, and do not jerk the cord. Before unplugging a 4-prong plug, rotate the plug counter-clockwise to unlock it.
- The GREEN ground wire in the factory-installed power cord is connected to the appliance. If it becomes necessary to remove or replace the power cord, be sure to connect the power cord's ground wire.
- Do not splash, pour, or spray water directly onto or into the appliance. This might cause short circuit, electric shock, corrosion, or failure.
- Do not make any alterations to the appliance. Alterations could result in electric shock, injury, fire, or damage to the appliance.
- This appliance is not intended for use by persons (including children) with reduced physical, sensory, or mental capabilities, or lack of experience and knowledge, unless they have been given supervision or instruction concerning use of the appliance by a person responsible for their safety.
- Children should be properly supervised around this appliance.
- Do not climb, stand, or hang on the appliance or door or allow children or animals to do so. Do not climb into the appliance or allow children or animals to do so. Death or serious injury could occur or the appliance could be damaged.
- Be careful not to pinch fingers when opening and closing the doors. Be careful when opening and closing the doors when children are in the area.
- Open and close the doors with care. Doors opened too quickly or forcefully may cause injury or damage to the appliance or surrounding equipment.
- Do not use combustible spray or place volatile or flammable substances in or near the appliance. They might catch fire.
- Keep the area around the appliance clean. Dirt, dust, or insects in the appliance could cause harm to individuals or damage to the equipment.
- Do not throw anything onto the shelves or load any single shelf with more than 120 lb. (54.5 kg) of product. They might fall off and cause injury.
- Do not place anything on top of the appliance. Foreign objects or moisture could enter the appliance and result in electric shock or fire.

⚠ WARNING, continued

- This appliance is designed only for storage of food. Employ sanitary methods. Use for any other purposes (for example, storage of chemicals or medical supplies such as vaccine and serum) could cause deterioration of stored items.
- Do not block the cabinet air inlet or outlet, otherwise cooling performance may be reduced.
- Do not tightly pack the cabinet. Allow some space between items to ensure good air flow. Also allow space between items and interior surfaces.
- Do not place any product on the floor of the cabinet. All product must be placed on properly installed shelves.
- Do not put warm or hot foods in the cabinet. Let them cool first, or they will raise the cabinet temperature and could deteriorate other foods in the cabinet or overload the appliance.
- All foods should be wrapped in plastic film or stored in sealed containers. Otherwise foods may dry up, pass their smells onto other foods, cause frost to develop, result in poor appliance performance, or increase the likelihood of cross-contamination. Certain dressings and food ingredients, if not stored in sealed containers, may accelerate corrosion of the evaporator, resulting in failure.
- Do not store items near the air outlet. They might freeze up and crack or break causing a risk of injury or contamination of other food.

NOTICE

- Protect the floor when moving the appliance to prevent damage to the floor.
- Keep ventilation openings, in the appliance enclosure or in the built-in structure, clear of obstruction. Do not place anything on top of the appliance. Blockage of airflow could negatively affect performance and damage the appliance.
- To prevent deformation or cracks, do not spray insecticide onto the plastic parts or let them come into contact with oil.
- To avoid damage to the gasket, use only the door handle when opening and closing.

I. Installation Instructions

⚠ WARNING

- This appliance must be installed in accordance with all applicable national, state, and local regulations.
- Appliance is heavy. Use care when lifting or positioning. Work in pairs when needed to prevent injury or damage.
- Do not tilt the appliance more than 45°.

A. Location

⚠ WARNING

- This appliance is not intended for outdoor use.
- Normal operating ambient temperature:
 - Refrigerators and Solid Door Freezers 45°F to 100°F (7°C to 38°C)
 - Glass Door Freezers 45°F to 80°F (7°C to 27°C)Operation of the appliance, for extended periods, outside of this normal temperature range may affect appliance performance.

For best operating results:

- The appliance should not be located next to ovens, grills, or other high heat producing equipment.
- The location should provide a firm and level foundation for the appliance.
- The appliance should not be located in a corrosive environment.
- Minimum Clearance:

Side	Top	Rear
3" (8 cm)	12" (31 cm)	1" (3 cm)

B. Checks Before Installation

⚠ WARNING

Refer to the nameplate for electrical specifications. The nameplate is located on the right side wall of the cabinet interior. For more electrical connection details, see "I.F. Electrical Connection." We reserve the right to make specification and design changes without prior notice.

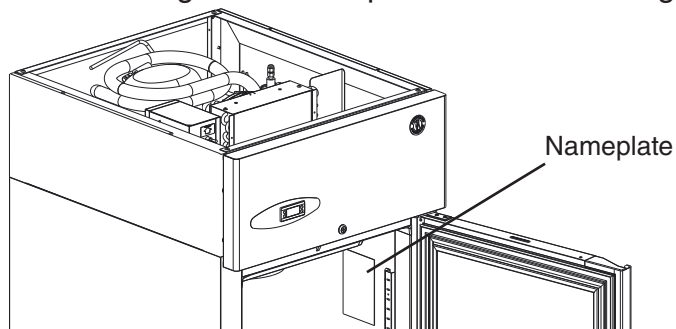

- Visually inspect the exterior of the shipping package and immediately report any damage to the carrier. Upon opening the package, any concealed damage should also be immediately reported to the carrier.
- Remove the shipping carton, tape, and packing material. Remove the protective plastic film from the exterior panels on all models and from the interior door panels on solid door models. If the appliance is exposed to the sun or to heat, remove the film after the appliance cools.
- Remove all accessory containers before discarding the packing materials. Dispose of all packing materials in a proper and environmentally responsible manner.
- Check for missing or damaged accessories.

C. Setup

1. Remove the Appliance from the Pallet and Install the Casters

- 1) Move as close to the final location as possible.
- 2) Remove the 2 bolts securing the unit to the pallet, then remove the unit from the pallet. Block the unit securely at a height of 8" (20 cm) off the floor. Do not lay the unit down. **NOTICE! Do not allow the door(s) to bear the weight of the appliance.**
- 3) Attach the casters to the bottom of the unit. Locking casters should be attached to the front of the unit. See Fig. 1.
- 4) While supporting the appliance to keep it from tipping, lower the casters to the floor.

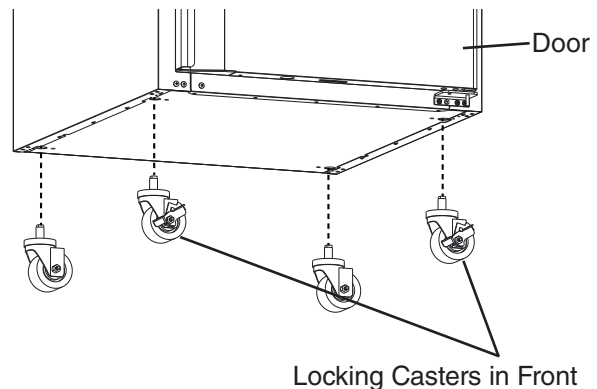

Fig. 1

2. Check the Refrigeration Circuit

- Visually check that the refrigerant lines do not rub or touch other lines or surfaces and that the condenser fan blade turns freely.
- Check that the compressor is snug on all mounting pads.

3. Position the Appliance and Lock the Front Casters

The front casters on the appliance are lockable. After positioning the appliance in its final location, lock the front casters.

4. Install the Shelves

Shelf support clips are provided in the accessory pack.

1. Place the shelf support clips into the pilasters (4 shelf support clips per shelf). Indexing holes are provided on the pilasters in evenly spaced intervals to assist you in positioning the support clips at the same height. See Fig. 2.
2. Place the shelves in position on the shelf support clips.

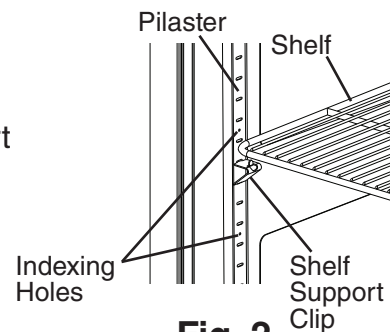

D. Door Reversal

This appliance is provided with a cabinet design which, after being delivered to the installation location, permits changing of the door swing from left to right or right to left. To change the door swing, an HS kit from your local Hoshizaki distributor is required. See the table below. **NOTICE! Improper installation of the HS kit may result in the doors not closing completely and/or the gaskets not sealing correctly.** For further details, contact your local Hoshizaki distributor or Hoshizaki Technical Support at 1-800-233-1940.



Door Type	Convert	HS Kit Number
Glass Full Door	Right Hinge to Left Hinge	HS-5177
	Left Hinge to Right Hinge	HS-5176
Solid Full Door	Right Hinge to Left Hinge	HS-3726
	Left Hinge to Right Hinge	HS-3725
Solid Half Door	Right Hinge to Left Hinge	HS-3725
	Left Hinge to Right Hinge	HS-3726

E. Unit Leveling

If necessary, use the shim kit and shim kit instructions provided to level the unit.

F. Electrical Connection

WARNING

- Electrical connection must meet national, state, and local electrical code requirements. Failure to meet these code requirements could result in death, electric shock, serious injury, fire, or severe damage to equipment.
 - This appliance requires an independent power supply of proper capacity. See the nameplate for electrical specifications. Failure to use an independent power supply of proper capacity can result in a tripped breaker, blown fuse, damage to existing wiring, or component failure. This could lead to heat generation or fire.
 - **115VAC Models: THIS APPLIANCE MUST BE GROUNDED:** This appliance is equipped with a NEMA 5-15 three-prong grounding plug  to reduce the risk of potential shock hazards. It must be plugged into a properly grounded, independent 3-prong wall outlet. If the outlet is a 2-prong outlet, it is your personal responsibility to have a qualified electrician replace it with a properly grounded, independent 3-prong wall outlet. Do not remove the ground prong from the plug and do not use an adapter plug. Failure to follow these instructions may result in death, electric shock, or fire.
 - **208/230VAC Models: THIS APPLIANCE MUST BE GROUNDED:** This appliance is equipped with a NEMA L14-20 four-prong locking, grounding plug  to reduce the risk of potential shock hazards. It must be plugged into a properly grounded, independent 4-prong wall outlet. If the outlet is a 3-prong outlet or a 4-prong non-locking outlet, it is your personal responsibility to have a qualified electrician replace it with a properly grounded, independent 4-prong locking wall outlet. Do not remove the ground prong from the plug and do not use an adapter plug. After plugging in, twist the plug clockwise to lock it into place. Failure to follow these instructions may result in death, electric shock, or fire.
 - To reduce the risk of electric shock, do not touch the power switch or plug with damp hands.
 - Make sure the power switch is in the "OFF" position before plugging in or unplugging the appliance to reduce the risk of electric shock.
 - Do not use an extension cord.
 - Do not use an appliance with a damaged power cord. The power cord should not be altered, jerked, bundled, weighed down, pinched, or tangled. Such actions could result in electric shock or fire. To unplug the appliance, be sure to pull the plug, not the cord, and do not jerk the cord.
 - The GREEN ground wire in the factory-installed power cord is connected to the appliance. If it becomes necessary to remove or replace the power cord, be sure to connect the power cord's ground wire.
- Usually an electrical permit and services of a licensed electrician are required.
 - The maximum allowable voltage variation is ± 10 percent of the nameplate rating.

G. Final Checklist

- 1) Is the appliance level?
- 2) Have the front casters been locked?
- 3) Is the appliance in a site where the ambient temperature is as specified below all year around?
 - Refrigerators and Solid Door Freezers 45°F to 100°F (7°C to 38°C)
 - Glass Door Freezers 45°F to 80°F (7°C to 27°C)

- 4) Have the minimum clearance requirements specified below been met?

Side	Top	Rear
3" (8 cm)	12" (31 cm)	1" (3 cm)

- 5) Have the shipping carton, tape, and packing material been removed from the appliance? Has the protective plastic film been removed from the exterior panels on all models and from the interior door panels on solid door models?
- 6) Have the appliance and accessories been checked for shipping damage?
- 7) Has the power supply voltage been checked or tested against the nameplate rating? Is the power supply a properly grounded, independent wall outlet? Does the electrical connection meet all national, state, and local code and regulation requirements.
- 8) Have the refrigerant lines been checked to make sure they do not rub or touch other lines or surfaces? Has the condenser fan blade been checked to make sure it turns freely? Is the compressor securely attached?
- 9) Have the shelves been properly installed?
- 10) Has the end user been given the instruction manual, and instructed on how to operate the appliance and the importance of the recommended periodic maintenance?
- 11) Has the end user been given the name and telephone number of an authorized service agent?
- 12) Has the warranty card been filled out and forwarded to the factory for warranty registration?

II. Operating Instructions

A. Important Notes About Usage

WARNING

- Only qualified service technicians should install and service this appliance.
- Failure to install, operate, and maintain the appliance in accordance with this manual may adversely affect safety, performance, component life, and warranty coverage.
- To reduce the risk of electric shock, do not touch the power switch or plug with damp hands.
- Do not splash, pour, or spray water directly onto or into the appliance. This might cause short circuit, electric shock, corrosion, or failure.
- This appliance is not intended for use by persons (including children) with reduced physical, sensory, or mental capabilities, or lack of experience and knowledge, unless they have been given supervision or instruction concerning use of the appliance by a person responsible for their safety.
- Children should be properly supervised around this appliance.
- Do not climb, stand, or hang on the appliance or door or allow children or animals to do so. Do not climb into the appliance or allow children or animals to do so. Death or serious injury could occur or the appliance could be damaged.
- Be careful not to pinch fingers when opening and closing the door. Be careful when opening and closing the door when children are in the area.
- Open and close the doors with care. Doors opened too quickly or forcefully may cause injury or damage to the appliance or surrounding equipment.
- Do not use combustible spray or place volatile or flammable substances in or near the appliance. They might catch fire.
- Keep the area around the appliance clean. Dirt, dust, or insects in the appliance could cause harm to individuals or damage to the equipment.
- Do not throw anything onto the shelves or load any single shelf with more than 120 lb. (54.5 kg) of product. They might fall off and cause injury.
- Do not place anything on top of the appliance. Foreign objects or moisture could enter the appliance and result in electric shock or fire.
- This appliance is designed only for storage of food. Employ sanitary methods. Use for any other purposes (for example, storage of chemicals or medical supplies such as vaccine and serum) could cause deterioration of stored items.
- Do not block the cabinet air inlet or outlet, otherwise cooling performance may be reduced.
- Do not tightly pack the cabinet. Allow some space between items to ensure good air flow. Also allow space between items and interior surfaces.
- Do not place any product on the floor of the cabinet. All product must be placed on properly installed shelves.

⚠ WARNING, continued

- Do not put warm or hot foods in the cabinet. Let them cool first, or they will raise the cabinet temperature and could deteriorate other foods in the cabinet or overload the appliance.
- All foods should be wrapped in plastic film or stored in sealed containers. Otherwise foods may dry up, pass their smells onto other foods, cause frost to develop, result in poor appliance performance, or increase the likelihood of cross-contamination. Certain dressings and food ingredients, if not stored in sealed containers, may accelerate corrosion of the evaporator, resulting in failure.
- Do not store items near the air outlet. They might freeze up and crack or break causing a risk of injury or contamination of other food.

NOTICE

- Protect the floor when moving the appliance to prevent damage to the floor.
- Keep ventilation openings, in the appliance enclosure or in the built-in structure, clear of obstruction. Blockage of airflow could negatively affect performance and damage the appliance.
- To prevent deformation or cracks, do not spray insecticide onto the plastic parts or let them come into contact with oil.
- To avoid damage to the gasket, use only the door handle when opening and closing.
- Do not leave the doors open.

B. Startup

⚠ WARNING

All parts are factory-adjusted. Improper adjustments may adversely affect safety, performance, component life, and warranty coverage.

IMPORTANT

At startup, there is a slight delay before the compressor starts.

- 1) Reach over the front panel to access the power switch—located on the front of the control box. See Fig. 3. Make sure the power switch is in the "OFF" position.

WARNING! To reduce the risk of electric shock, do not touch the power switch or plug with damp hands.

- 2) Plug the appliance into the electrical outlet.
- 3) Move the power switch to the "ON" position to start the cool-down process.
- 4) Allow the appliance to cool down prior to loading it with food products.

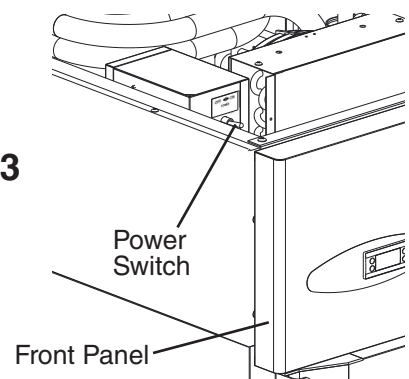

Fig. 3

C. Controls and Adjustments

1. Temperature Display

The cabinet temperature is displayed on the control module. See Fig. 4. The display default is °F, but it can be changed to read °C. To change, see "II.C.3. Changing the Temperature Display Scale (°F or °C)."

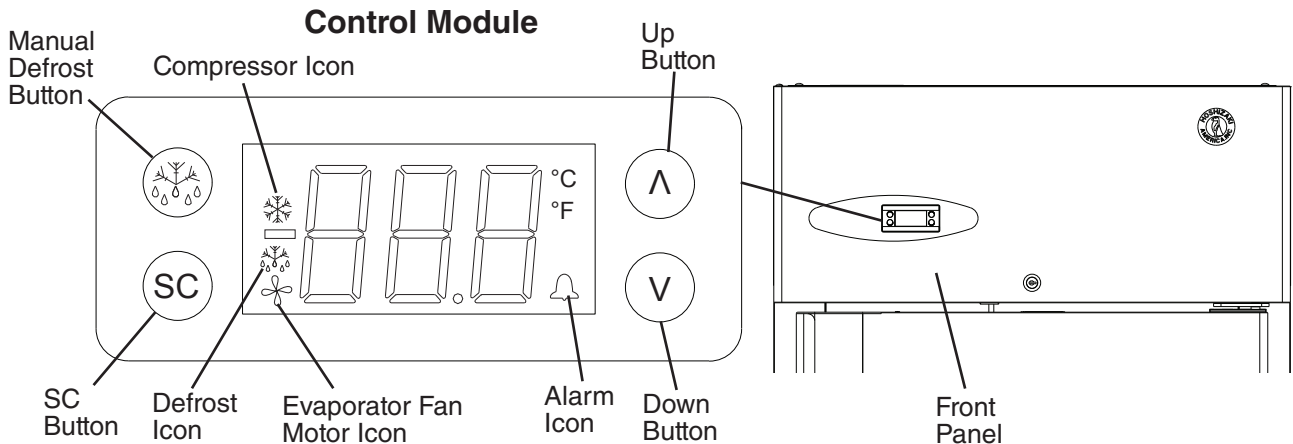

Fig. 4

2. Adjusting the Temperature Setpoint

The temperature setpoint is the value for the average cabinet temperature. The temperature differential for the compressor to turn on and off is $\pm 3^{\circ}\text{F}$ ($\pm 1.7^{\circ}\text{C}$) of the temperature setpoint. For example, for a refrigerator temperature setpoint of 36°F (2°C), the compressor comes on at 39°F (3.7°C), and the compressor goes off at 33°F (0.3°C). If necessary, adjust the temperature setpoint temperature as follows:

- 1) To change the temperature setpoint, press and hold the up button briefly and then release. The current temperature setpoint appears. Press the up or down button until the desired value is displayed. After a few seconds, the display returns to the current cabinet temperature and the temperature setpoint is saved. **NOTICE! Do not adjust the temperature setpoint more than 2°F (1°C) at a time. Allow the temperature to stabilize for a minimum of 8 hours before making further temperature setpoint adjustments.**
 - For refrigerators, the temperature setpoint is adjustable between 31°F and 52°F (-0.5°C and 11°C). The factory default is 33°F (1°C).
 - For freezers, the temperature setpoint is adjustable between -10°F and $+12^{\circ}\text{F}$ (-24°C and -11°C). The factory default is -4°F (-20°C).

3. Changing the Temperature Display Scale (°F or °C)

To change the temperature display scale, follow the steps below. The factory default is °F.

- 1) Press and hold both the up and down buttons for 5 seconds. "PAS" appears briefly in the display, then "000" appears.
- 2) Press the up button to change the display to "001".
- 3) Press the SC button. "EHE" appears in the display. Press the up or down button until "diS" is displayed.
- 4) Press the SC button. "CFu" appears in the display. Press the SC button again. The current temperature display scale setting appears. Press the up or down button to change the temperature display scale.
- 5) Press the SC button to save the setting. Wait 1 minute or press the manual defrost button twice to return to the temperature display.

4. Light Switch for Glass Door Models



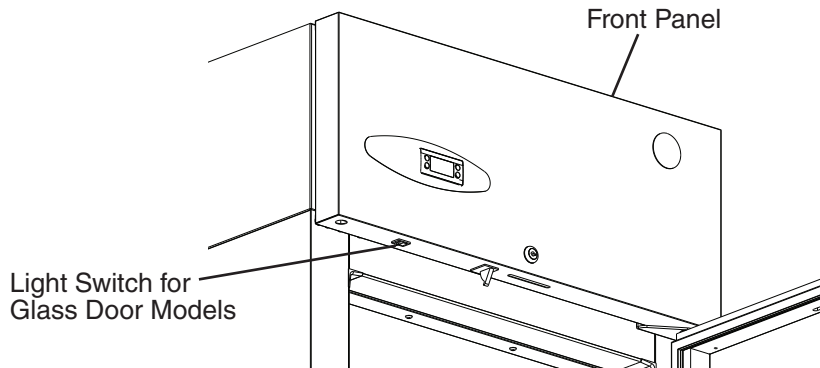

Glass door models feature lights that are controlled by a light switch located on the bottom of the front panel. See Fig. 5.

Fig. 5



D. Control Module Icons

Control module icons inform you of energized components and if the appliance is in alarm.

Control Module Icons	
Icon	Meaning
	Compressor Compressor running.
	Defrost Appliance is in defrost cycle. See "II.E. Defrost" for details.
	Evaporator Fan Motor Evaporator fan motor is running. Evaporator fan motor de-energizes when door is open.
	Alarm Appliance is in alarm. See "II.G. Alarm Safeties" for details.

E. Defrost

1. Refrigerators

Refrigerators use a time-initiated, off-cycle defrost and defrost once every 2 hours. As soon as power is turned on the 2-hr. defrost timer starts. Once the 2-hr. defrost timer terminates, defrost begins. When the defrost thermistor warms to 44°F (6.6°C), defrost terminates. The minimum defrost time is 20 minutes and the maximum defrost time is 1 hour. Cabinet temperature is displayed during defrost.

2. Freezers

Freezers use a cumulative compressor run time-initiated, heated defrost. Once the compressor energizes, the 5-hour cumulative compressor run timer starts. When the cumulative compressor run timer terminates, defrost begins. Cabinet temperature is not displayed during defrost; "dEF" is displayed in its place. When the defrost thermistor warms to 45°F (7.2°C), defrost terminates. A 3-minute compressor delay timer, a 7-minute evaporator fan motor delay timer, and an 18-minute temperature display delay timer start. As the delay timers terminate, the related components energize. Note that the 7-minute evaporator fan motor delay time is a maximum; if the defrost thermistor cools to 25°F (-3.9°C) before the 7-minute evaporator fan motor delay timer terminates, the evaporator fan motor will energize. Freezers have a minimum defrost interval of 5 hours. The minimum defrost time is 5 minutes and the maximum defrost time is 1 hour.

3. Manual Defrost

To initiate a manual defrost, press the manual defrost button.

F. Food Storage

WARNING

- This appliance is designed only for storage of food. Employ sanitary methods. Use for any other purposes (for example, storage of chemicals or medical supplies such as vaccine and serum) could cause deterioration of stored items.
- Do not block the cabinet air inlet or outlet, otherwise cooling performance may be reduced.
- Do not tightly pack the cabinet. Allow some space between items to ensure good air flow. Also allow space between items and interior surfaces.
- Do not place any product on the floor of the cabinet. All product must be placed on properly installed shelves.
- Do not put warm or hot foods in the cabinet. Let them cool first, or they will raise the cabinet temperature and could deteriorate other foods in the cabinet or overload the appliance.
- All foods should be wrapped in plastic film or stored in sealed containers. Otherwise foods may dry up, pass their smells onto other foods, cause frost to develop, result in poor appliance performance, or increase the likelihood of cross-contamination. Certain dressings and food ingredients, if not stored in sealed containers, may accelerate corrosion of the evaporator, resulting in failure.
- Do not store items near the air outlet. They might freeze up and crack or break causing a risk of injury or contamination of other food.

G. Alarm Safeties

Alarm signals are designed to protect the appliance and food product. These alarms give information or warnings in the event the appliance is operating out of acceptable parameters. Should one of the alarms occur, follow the instructions in the table below to address the alarm. The alarm code and alarm icon flash with audible alarm.

Alarm Signals		
Alarm Code	Problem	Corrective Action/Reset Details
E01	Cabinet Thermistor Malfunction Alarm Cabinet thermistor has failed.	Call a qualified service technician. Beeps for 10 seconds, then silent for 50 seconds. To silence the alarm, press and release the up button. Appliance cycles 5 min. on, 5 min. off.
E02	Defrost Thermistor Malfunction Alarm Defrost thermistor has failed.	Call a qualified service technician. Beeps for 10 seconds, then silent for 50 seconds. To silence the alarm, press and release the up button. Appliance cycles on and off with cabinet thermistor.
Hi	High Temperature Alarm Refrigerator: Cabinet temperature has remained above 57°F (13.9°C) for more than 2 hours. Freezer: Cabinet temperature has remained above 26°F (-3.3°C) for more than 2 hours.	If obvious corrections such as closing doors and cleaning the air filter and/or condenser do not bring temperature back in range, call a qualified service technician. Beeps for 10 seconds, then silent for 50 seconds. To silence the alarm and clear "Hi" from the display, press and release the up button. The alarm icon stays on. Automatically resets when temperature returns to normal.
Lo	Low Temperature Alarm Refrigerator: Cabinet temperature has remained below 26°F (-3.3°C) for more than 2 hours. Freezer: Cabinet temperature has remained below -23°F (-30.6°C) for more than 2 hours.	If obvious corrections do not bring the temperature back in range, call a qualified service technician. Beeps for 10 seconds, then silent for 50 seconds. To silence the alarm and clear "Lo" from the display, press and release the up button. The alarm icon stays on. Automatically resets when temperature returns to normal.

H. Safety Devices

1. Compressor External or Internal Overload

If combined temperature/amperage value is above the limit specified by the compressor manufacturer, the compressor overload operates independently to turn off the compressor. The compressor overload de-energizes the compressor until the temperature/amperage value returns to an acceptable level.

2. Short-Cycle Protection

There is a 2-minute minimum off-time and on-time for the compressor.

Note: Time may vary with compressor overload or high-pressure switch activation.

3. High-Pressure Switch

If pressure on the high-side of the appliance exceeds Hoshizaki specifications, the high-pressure switch activates and interrupts the compressor circuit, de-energizing the compressor until the pressure returns to an acceptable level.

I. Cooling Performance

Be sure the appliance is properly installed and located for optimum cooling performance. If cooling performance is not at its optimum level, check the following items:

- Door(s) opened too often.
- Door(s) left open. Close.
- Cabinet too tightly packed or cabinet air inlet/outlet blocked. Allow some space between items to ensure good air flow.
- Warm or hot foods inside. Take them out until they cool down more.
- Ambient temperature too high. Avoid installation near high heat producing equipment or exposure to direct sunlight.
- Temperature setpoint too high. Readjust it to a lower temperature.
- Appliance in defrost cycle. The cabinet temperature may rise temporarily during the defrost cycle, but this will not affect the food inside.

J. Cabinet Condensation

In the event condensation develops on the cabinet exterior, check the following items:

- Door(s) left open. Close.
- Ambient humidity too high. In high humidity areas it may be necessary to wipe off the cabinet frame occasionally.

III. Cleaning and Maintenance Instructions

A. Cleaning

⚠ WARNING

- Before cleaning the appliance, move the power switch to the "OFF" position and unplug the appliance to prevent electric shock by unexpected entrance of water into the appliance or injury by moving parts. To reduce the risk of electric shock, do not touch the power switch or plug with damp hands.
- Before cleaning the appliance, move all foods into another clean refrigerator or freezer.
- Do not splash water directly onto the appliance. This might cause short circuit, electric shock, corrosion, or failure.
- Carefully follow instructions provided with cleaning and sanitizing products.

NOTICE

- To prevent damage to the plastic surfaces, do not use the following: hot water, thinner, benzine, alcohol, petroleum, soap powder, polishing powder, alkaline cleaner, acid, scouring pad and especially those strong cleaners for use on a ventilating fan or a cooking range.
- To prevent corrosion and damage to stainless steel surfaces, use only products formulated for use on stainless steel appliances. Do not use steel wool, abrasive products, or products containing sodium hypochlorite (chlorine bleach).
- Use a clean cloth for cleaning.

1. Exterior

Wipe the exterior occasionally with a clean, soft cloth. Use a damp cloth containing a neutral cleaner to wipe off oil or dirt buildup. Clean any rust colored spots using a non-abrasive cleanser.

2. Cabinet Interior

Spills should be wiped up promptly to avoid unpleasant odors. The cabinet interior should be cleaned periodically with a mild soap or detergent and warm water. **NOTICE! Do not use hot water to clean the cabinet interior.**

3. Door Gaskets

Door gaskets should be cleaned regularly with mild soap and warm water to remove dirt and grease.

4. Shelves

Remove and clean regularly.

5. Glass Door

Wipe occasionally with a clean, soft cloth. Use a damp cloth containing a neutral cleaner to wipe off oil or dirt buildup.

B. Maintenance/Troubleshooting

The appliance must be maintained in accordance with the instruction manual. Consult with your local Hoshizaki Certified Service Representative about maintenance service. Failure to maintain the appliance in accordance with this manual may adversely affect safety, performance, component life, and warranty coverage.

WARNING

- Only qualified service technicians should service the appliance.
- Move the power switch to the "OFF" position and unplug the appliance before performing maintenance or troubleshooting to prevent electric shock or injury by moving parts. To reduce the risk of electric shock, do not touch the power switch or plug with damp hands.
- Before performing maintenance or troubleshooting, move all foods into another clean refrigerator or freezer.

Troubleshooting	
Problem	Possible Solution
Insufficient cooling; compressor protector or high-pressure switch tripping	See "II.I. Cooling Performance." If the items listed do not resolve the problem, clean the condenser. See "III.B.1 Condenser" below.
Water or ice in the bottom of the cabinet	Clean the condensate drain boot. See "III.B.2. Condensate Drain Boot" below.

1. Condenser

The condenser must be cleaned at least once a year. More frequent cleaning may be required in some conditions. Use a brush or vacuum cleaner to clean the condenser as required.

2. Condensate Drain Boot

The condensate drain boot must be cleaned at least once a year. More frequent cleaning may be required in some conditions to maintain proper flow. Follow the steps below.

- 1) Unplug the appliance from the electrical outlet. **WARNING! To reduce the risk of electric shock, do not touch the plug with damp hands.**
- 2) Remove the drain boot from the drain hose. See Fig. 6. **WARNING! On freezer models, be careful not to affect the position of the drain heater.**
- 3) Clean the drain boot.
- 4) Replace the drain boot in its correct position.
NOTICE! Be sure the drain boot is positioned into the condensate pan.
WARNING! On freezer models, be careful not to affect the position of the drain heater.
- 5) Plug the appliance back in.

Fig. 6

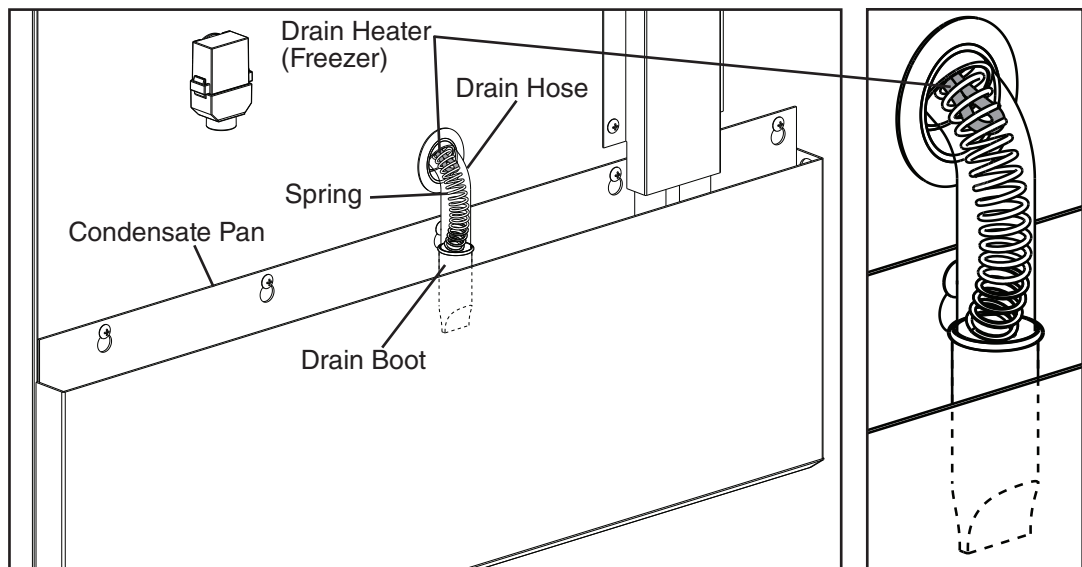

3. Power Supply Connection

If the plug or power cord is damaged, contact your local Hoshizaki service representative or local Hoshizaki distributor immediately and ask for repairs.

All other maintenance or service on this appliance should be performed in accordance with the Hoshizaki Service Manual by a qualified service technician.

IV. Preparing the Appliance for Periods of Non-Use

When shutting down the appliance for periods of non-use, follow the instructions below.

⚠ WARNING

Prevent the doors from closing to reduce the risk of children getting trapped.
--

<i>NOTICE</i>

Clean the appliance. See "III.A. Cleaning" for details.

- 1) Before shutting down the appliance, move the stored food into another refrigerator or freezer.
- 2) Move the power switch to the "OFF" position and unplug the appliance.
WARNING! To reduce the risk of electric shock, do not touch the power switch or plug with damp hands.

V. Disposal

When disposing of the appliance, follow the instructions below.

⚠ WARNING

Remove the door to reduce the risk of children getting trapped. Leave the shelves in place so that children may not easily climb inside.
--

This appliance contains refrigerant and must be disposed of in accordance with applicable national, state, and local codes and regulations. Refrigerant must be recovered by properly certified service personnel.

HOSHIZAKI AMERICA, INC.

618 Hwy. 74 South, Peachtree City, GA 30269 USA (P) 770.487.2331 (F) 770.487.3360 hoshizakiamerica.com 1A4187-012