



HOSHIZAKI

Instruction Manual

Commercial Series
Refrigerated Kitchen Equipment

Models
Refrigerated Prep Table with Raised Rail



hoshizakiamerica.com

Issued: 2-10-2017
Revised: 8-1-2018

⚠ WARNING

Only qualified service technicians should install and service the appliance. To obtain the name and phone number of your local Hoshizaki Certified Service Representative, visit www.hoshizaki.com. No installation or service should be undertaken until the technician has thoroughly read this Instruction Manual. Likewise, the owner/manager should not proceed to operate the appliance until the installer has instructed them on its proper operation. Failure to install, operate, and maintain the appliance in accordance with this manual may adversely affect safety, performance, component life, and warranty coverage. Proper installation is the responsibility of the installer. Product failure or property damage due to improper installation is not covered under warranty.

Hoshizaki provides this manual primarily to assist qualified service technicians in the installation, maintenance, and service of the appliance.

Should the reader have any questions or concerns which have not been satisfactorily addressed, please call, send an e-mail message, or write to the Hoshizaki Technical Support Department for assistance.

Phone: 1-800-233-1940; (770) 487-2331

Fax: 1-800-843-1056; (770) 487-3360

E-mail: techsupport@hoshizaki.com

HOSHIZAKI AMERICA, INC.

618 Highway 74 South

Peachtree City, GA 30269

Attn: Hoshizaki Technical Support Department

Web Site: www.hoshizaki.com

NOTE: To expedite assistance, all correspondence/communication **MUST** include the following information:

- Model Number _____
- Serial Number _____
- Complete and detailed explanation of the problem.

IMPORTANT

This manual should be read carefully before the appliance is installed and operated. Read the warnings and guidelines contained in this booklet carefully as they provide essential information for the continued safe use and maintenance of the appliance. Retain this booklet for any further reference that may be necessary.

CONTENTS

Important Safety Information	4
I. Installation Instructions	7
A. Location	7
B. Checks Before Installation.....	8
C. Setup.....	8
D. Door Reversal.....	12
E. Door/Drawer Reversal	16
F. Electrical Connection	23
G. Final Checklist	24
II. Operating Instructions.....	25
A. Important Notes About Usage	25
B. Startup	27
C. Controls and Adjustments	27
1. Temperature Display.....	27
2. Adjusting the Temperature Setpoint and Rail and Cabinet Cooling	28
4. Changing the Temperature Display Scale (°F or °C)	29
D. Control Module Icons	29
E. Defrost.....	29
F. Alarm Safeties.....	30
G. Food Storage	31
H. Safety Devices	31
I. Cooling Performance	32
J. Cabinet Condensation	32
III. Cleaning and Maintenance Instructions.....	33
A. Cleaning	33
1. Exterior.....	33
2. Cabinet Interior	33
3. Door/Drawer Gaskets	33
4. Shelves	33
5. Drawers	34
6. Cutting Board.....	34
7. Pans	34
8. Rail, Rail Dividers, and Rail Cover.....	34
9. Rail Air Duct.....	35
B. Maintenance.....	36
1. Condenser.....	36
2. Condensate Drain.....	37
3. Power Supply Connection.....	37
IV. Preparing the Appliance for Periods of Non-Use	38
V. Disposal	39

Important Safety Information

Throughout this manual, notices appear to bring your attention to situations which could result in death, serious injury, damage to the appliance, or damage to property.

⚠ WARNING Indicates a hazardous situation which could result in death or serious injury.

NOTICE Indicates a situation which could result in damage to the appliance or property.

IMPORTANT Indicates important information about the use and care of the appliance.

⚠ WARNING

The appliance should be destined only to the use for which it has been expressly conceived. Any other use should be considered improper and therefore dangerous. The manufacturer cannot be held responsible for injury or damage resulting from improper, incorrect, and unreasonable use. Failure to install, operate, and maintain the appliance in accordance with this manual will adversely affect safety, performance, component life, and warranty coverage.

To reduce the risk of death, electric shock, serious injury, or fire, follow basic precautions including the following:

- Only qualified service technicians should install and service the appliance.
- The appliance must be installed in accordance with applicable national, state, and local codes and regulations.
- Appliance is heavy. Use care when lifting or positioning. Work in pairs when needed to prevent injury or damage. Do not lift using the refrigeration area, the top section, or the doors/drawers.
- To reduce the risk of electric shock, do not touch the plug with damp hands.
- Unplug the appliance before servicing.
- The appliance requires an independent power supply of proper capacity. See the nameplate for electrical specifications. Failure to use an independent power supply of proper capacity can result in a tripped breaker, blown fuse, damage to existing wiring, or component failure. This could lead to heat generation or fire.
- **THE APPLIANCE MUST BE GROUNDED.** The appliance is equipped with a NEMA 5-15 three-prong grounding plug  to reduce the risk of potential shock hazards. It must be plugged into a properly grounded, independent 3-prong wall outlet. If the outlet is a 2-prong outlet, it is your personal responsibility to have a qualified electrician replace it with a properly grounded, independent 3-prong wall outlet. Do not remove the ground prong from the power cord and do not use an adapter plug. Failure to follow these instructions may result in death, electric shock, or fire.
- Do not use an extension cord.

⚠ WARNING, continued

- Do not use an appliance with a damaged power cord. The power cord should not be altered, jerked, bundled, weighed down, pinched, or tangled. Such actions could result in electric shock or fire. To unplug the appliance, be sure to pull the plug, not the cord, and do not jerk the cord.
- The GREEN ground wire in the factory-installed power cord is connected to the appliance. If it becomes necessary to remove or replace the power cord, be sure to connect the power cord's ground wire.
- Do not splash, pour, or spray water directly onto or into the appliance. This might cause short circuit, electric shock, corrosion, or failure.
- Do not make any alterations to the appliance. Alterations could result in electric shock, injury, fire, or damage to the appliance.
- The appliance is not intended for use by persons (including children) with reduced physical, sensory, or mental capabilities, or lack of experience and knowledge, unless they have been given supervision or instruction concerning use of the appliance by a person responsible for their safety.
- Children should be properly supervised around the appliance.
- Do not climb, stand, or hang on the appliance or doors/drawers or allow children or animals to do so. Do not climb into the appliance or allow children or animals to do so. Death or serious injury could occur or the appliance could be damaged.
- Be careful not to pinch fingers when opening and closing the doors/drawers or rail cover. Be careful when opening and closing the doors/drawers or rail cover when children are in the area.
- Open and close the doors/drawers and rail cover with care. Opening the doors/drawers or rail cover too quickly or forcefully may cause injury or damage to the appliance or surrounding equipment.
- Do not use combustible spray or place volatile or flammable substances in or near the appliance. They might catch fire.
- Keep the area around the appliance clean. Dirt, dust, or insects in the appliance could cause harm to individuals or damage to the equipment.
- Do not throw anything onto the shelves or load any single shelf with more than 120 lb. (54.5 kg) of product. They might fall off and cause injury.
- Do not load any single drawer with more than 150 lb. (68 kg) of product. Depending on the weight of product in the drawers, secure the unit as necessary to prevent it from overturning. Do not open more than one drawer at a time.
- The appliance is designed only for temporary storage of food. Employ sanitary methods. Use for any other purposes (for example, storage of chemicals or medical supplies such as vaccine and serum) could cause deterioration of stored items.
- Do not block air inlets or outlets, otherwise cooling performance may be reduced.
- Do not tightly pack the cabinet. Allow some space between items to ensure good air flow. Also allow space between items and interior surfaces.

⚠ WARNING, continued

- Do not put warm or hot foods in the cabinet. Let them cool first, or they will raise the cabinet temperature and could deteriorate other foods in the cabinet or overload the appliance.
- All foods in the cabinet should be wrapped in plastic film or stored in sealed containers. Otherwise foods may dry up, pass their smells onto other foods, cause frost to develop, result in poor appliance performance, or increase the likelihood of cross-contamination. Certain dressings and food ingredients, if not stored in sealed containers, may accelerate corrosion of the evaporator, resulting in failure.
- Do not store items near air outlets in the cabinet. Otherwise, items may freeze up and crack or break causing a risk of injury or contamination of other food.
- The entire rail must always be covered by rail dividers and pans. Otherwise, the appliance will not cool properly. Use only pans up to 6" (15 cm) deep. Do not use damaged rail dividers or pans.
- Ingredients must be pre-chilled to 37°F (3°C) or less before placing in rail.
- Keep the rail cover closed when not actively preparing food.
- The rail is for keeping ingredients cool while preparing food. If not actively preparing food for a long period such as overnight, seal pans with plastic wrap in addition to closing the rail cover. Depending on conditions, the cabinet temperature setting may need to be adjusted to prevent items from freezing. Alternatively, seal ingredients and store them in a refrigerator or freezer.
- For CPT46(-D) models, the anti-tip bracket must be properly installed and adjusted. Otherwise, the unit may tip, resulting in injury or damage.

NOTICE

- Protect the floor when moving the appliance to prevent damage to the floor.
- Keep ventilation openings, in the appliance enclosure or in the built-in structure, clear of obstruction. The factory-installed rear bumpers must be in place to ensure proper rear clearance. Blockage of airflow could negatively affect performance and damage the appliance.
- Do not allow the appliance to bear any outside weight.
- To prevent deformation or cracks, do not spray insecticide onto the plastic parts or let them come into contact with oil.
- To avoid damage to the gasket, use only the door/drawer handle when opening and closing.
- Do not leave the doors/drawers open.
- To avoid damage to the top seal, do not lift the appliance by the top section or remove the top section.
- Do not place anything on top of the rail cover and do not lift the appliance by the rail cover. The rail cover is not designed to bear any outside weight.
- Do not place anything on the air duct panels beneath the pans in the rail. The air duct panels are not load-bearing.

I. Installation Instructions

WARNING

- The appliance must be installed in accordance with all applicable national, state, and local regulations.
- Appliance is heavy. Use care when lifting or positioning. Work in pairs when needed to prevent injury or damage. Do not lift using the refrigeration area, the top section, or the doors/drawers.
- Do not tilt the appliance more than 45°.

A. Location

WARNING

- The appliance is not intended for outdoor use.
- Certified to maintain NSF temperatures between 45°F to 86°F (7°C to 30°C). Engineered to maintain NSF temperatures up to 100°F (38°C).
- Operation of the appliance, for extended periods, outside of these temperature ranges may affect appliance performance.

For best operating results:

- The appliance should not be located next to ovens, grills, or other high heat producing equipment.
- The location should provide a firm and level foundation for the appliance.
- The appliance should not be located in a corrosive environment.
- Allow 1" (3 cm) clearance at sides for proper air circulation. The factory-installed rear bumpers must be in place to ensure proper rear clearance. A minimum of 10" (25 cm) clearance above the rail should be provided to allow the rail cover to open.

B. Checks Before Installation

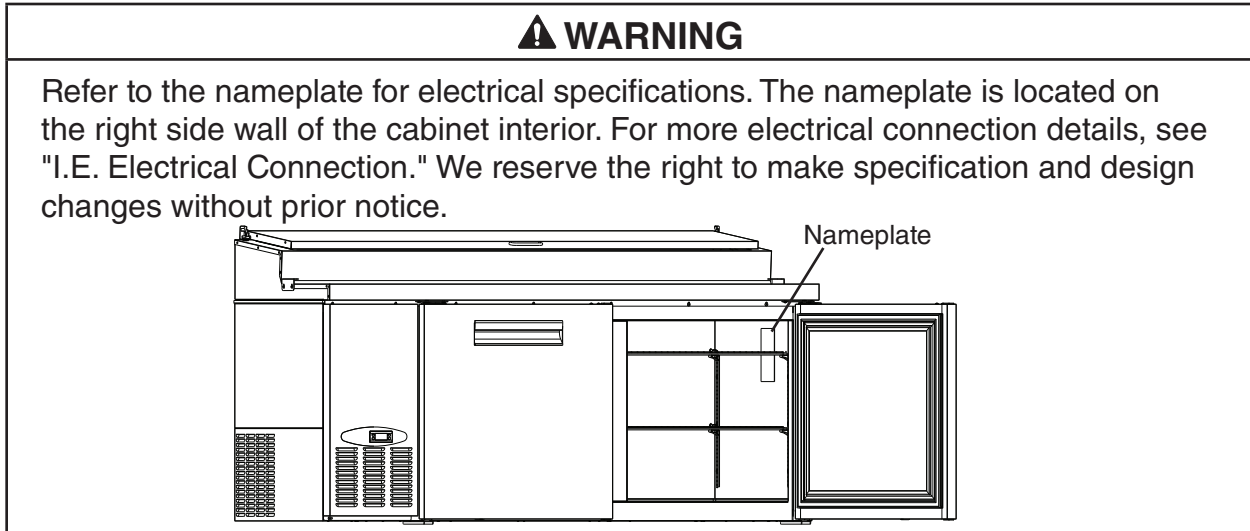

- Visually inspect the exterior of the shipping package and immediately report any damage to the carrier. Upon opening the package, any concealed damage should also be immediately reported to the carrier.
- Remove the shipping carton, tape, and packing material. Also remove the protective plastic film from both the exterior panels and the interior door/drawer panel. If the appliance is exposed to the sun or to heat, remove the film after the appliance cools.
- Remove all accessory containers before discarding the packing materials. Dispose of all packing materials in a proper and environmentally responsible manner.
- Check for missing or damaged accessories.

C. Setup

1. Remove the Appliance from the Pallet

- 1) Move as close to the final location as possible.
- 2) Remove the 2 bolts securing the appliance to the pallet, then remove the appliance from the pallet. Block the appliance securely at a height of 8" (20 cm) off the floor. **NOTICE! Do not place blocks under the refrigeration area or doors/drawers of the appliance. Do not lay the appliance down.**
- 3) Attach the casters to the bottom of the appliance. Locking casters should be attached to the front of the appliance. See Fig. 1. **NOTICE! Ensure casters are completely threaded into appliance and tight.**

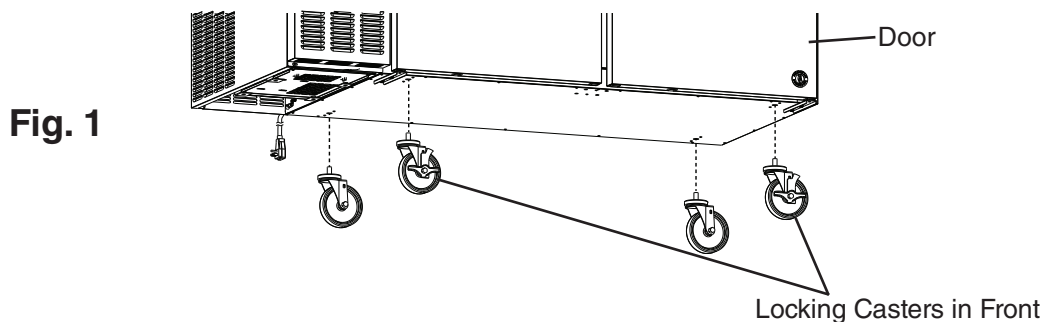

2. Check the Refrigeration Circuit

Visually check that the refrigerant lines do not rub or touch other lines or surfaces and that the condenser fan blade turns freely.

3. Position the Appliance and Lock the Front Casters

The front casters on the appliance are lockable. After positioning the appliance in its final location, lock the front casters.

4. For CPT46(-D) Models, Install the Anti-Tip Bracket

- 1) Attach the anti-tip bracket to the bottom of the appliance with the two 4x8 T2 screws provided. See Fig. 2.
- 2) Adjust the leg on the anti-tip bracket. The maximum gap between the leg and the floor is 1/2" (13 mm) **WARNING! The anti-tip bracket must be properly installed and adjusted. Otherwise, the unit may tip, resulting in injury or damage.**

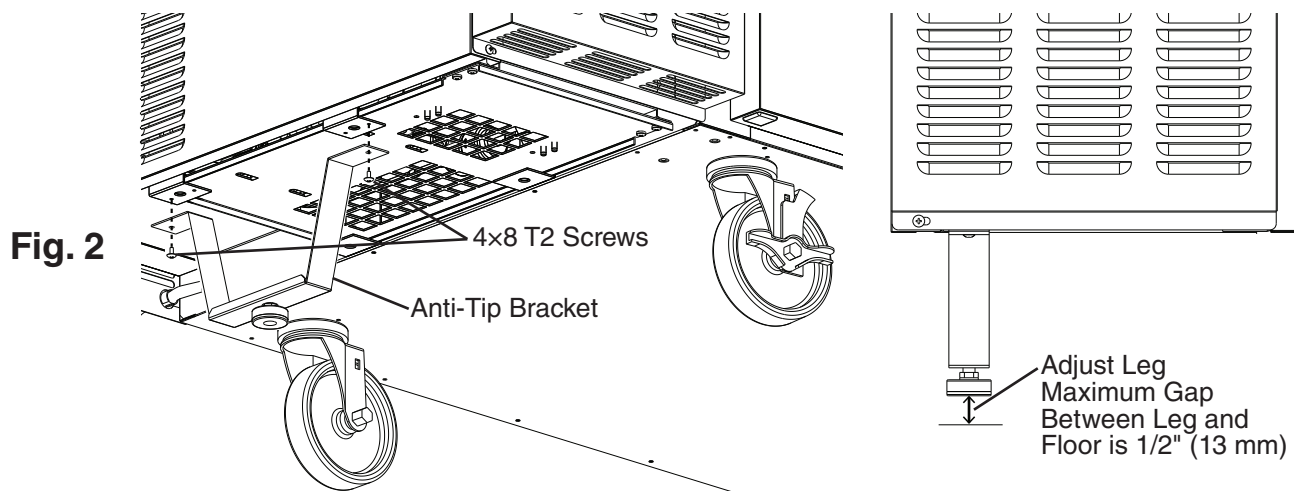

5. Install the Shelves

- 1) For each shelf, place the shelf support clips into the pilasters at the desired height (4 shelf support clips per shelf). See Fig. 3.
- 2) Place the shelves in position on the support clips.

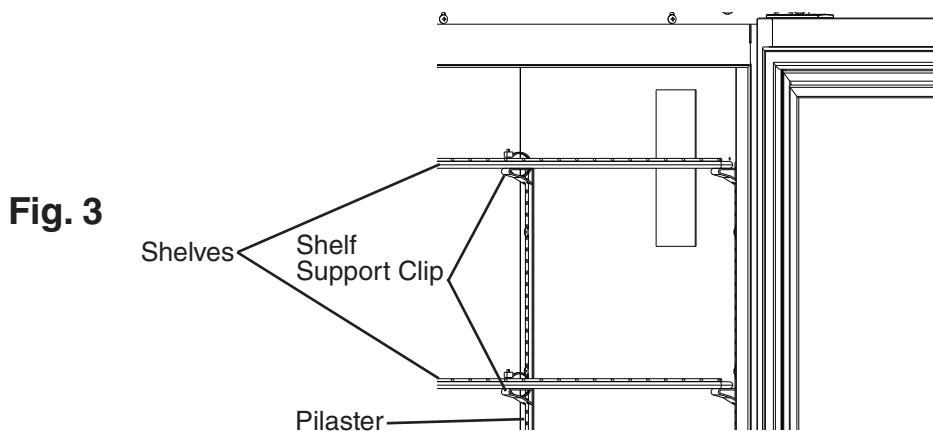

6. Confirm Rail Cover Operation

The rail cover's rear pins are inserted into the rear slots on both brackets. Use the rail cover's front pins and the notches on the brackets to place the rail cover in the open position. You can use either set of notches. The hollow side of the rail cover faces down. See Fig. 4. **WARNING! When the rail cover is open, make sure the rear pins on both sides of the rail cover are securely in the rear slots and the front pins are resting securely in the notches. Otherwise, the rail cover could close suddenly and cause injury.**

Fig. 4

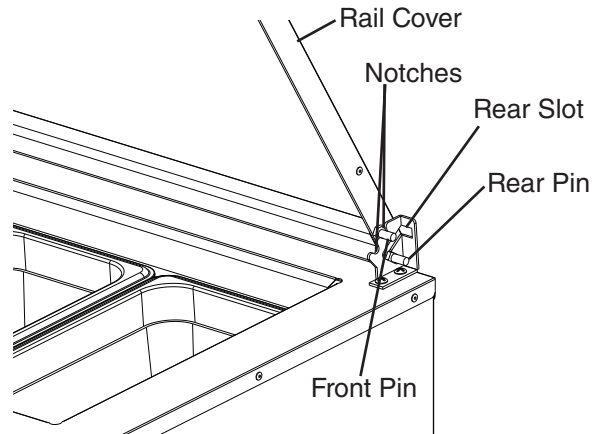

7. Confirm Rail Dividers and Pans are in Place

Confirm rail dividers and 1/3 size pans included with the appliance are in place. See Fig. 5.

- The entire rail must always be covered by rail dividers and pans. Otherwise, the appliance will not cool properly.
- Use only pans up to 6" (15 cm) deep. Do not use damaged rail dividers or pans.
- Wash the pans before use.
- At startup, leave the pans empty until the appliance cools down.
- On some models, an extra rail divider is included. Use the extra rail divider if a gap remains after all pans and all other rail dividers are in place. Some pans on the market are slightly larger and do not require the extra rail divider.

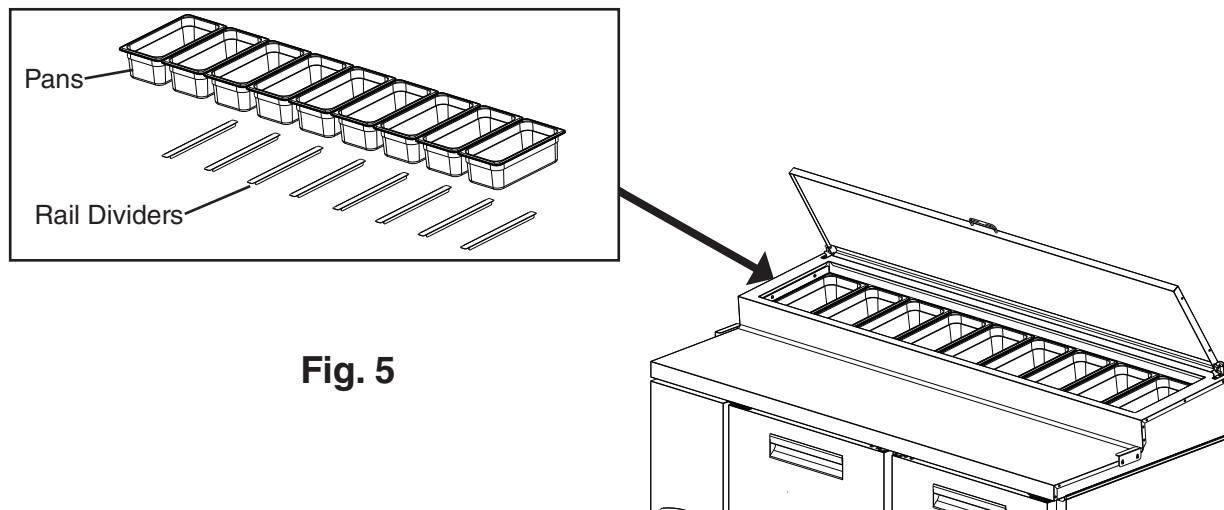

Fig. 5

8. Attach the Cutting Board

- 1) Loosen, but do not remove, the screws securing the cutting board brackets. See Fig. 6.
- 2) Slide the cutting board under the cutting board brackets, then tighten the screws.

WARNING! Make sure the cutting board brackets and cutting board are secure. Otherwise, the cutting board could come off and cause injury.

Note: Wash the cutting board before use.

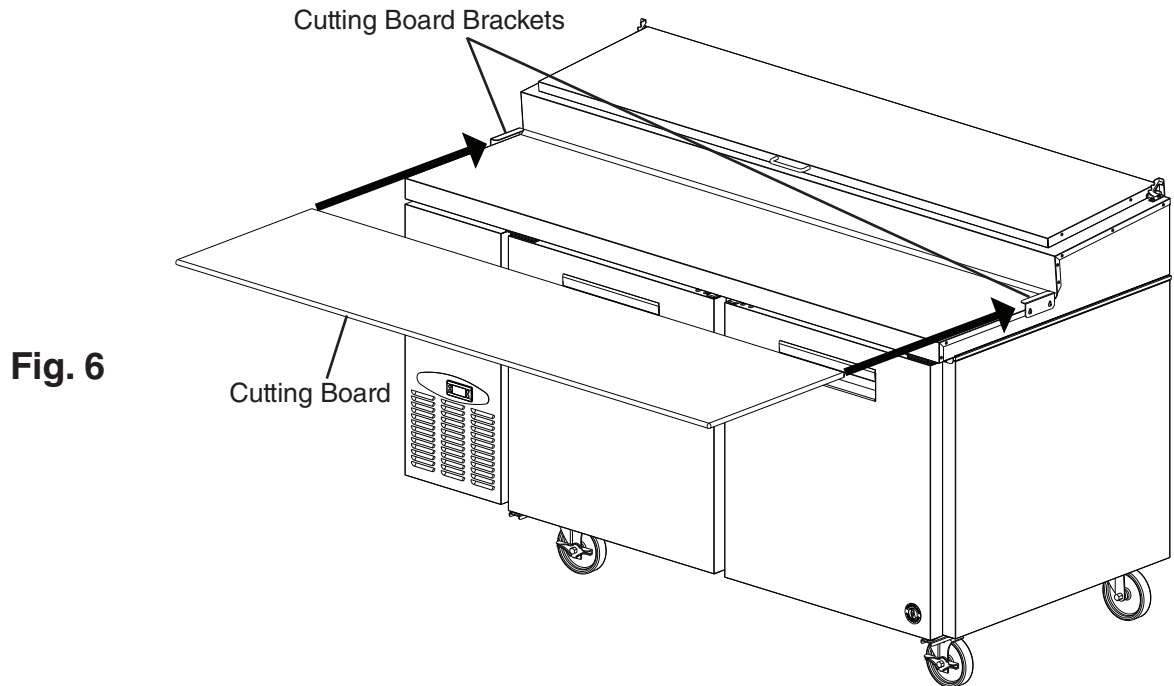

Fig. 6

D. Door Reversal

The appliance is provided with a cabinet design which, after being delivered to the installation location, permits changing of the door swing from left to right or right to left. To change the door swing, follow the steps below. Example shows change from right hinged to left hinged.

⚠ WARNING

- Wear proper PPE (personal protection equipment) when executing these procedures (safety glasses and gloves).
- Keep fingers away from edge of upper hinge bracket. Spring cartridge can cause the upper hinge bracket to move suddenly with extreme force.

Door and Lower Hinge Removal and Relocation

- 1) Remove all items from the appliance. Make sure the appliance is unplugged from the electrical outlet. Move the appliance out for ease of access then lock the casters.
- 2) With the door closed, loosen, but do not remove, the upper hinge bracket outer screw. See Fig. 7. Next, open the door to the fully open position and remove the upper hinge bracket inner screw. See Fig. 8.
- 3) Slide the upper hinge bracket out from under the outer screw and remove the door. **WARNING! Keep away from upper hinge bracket. Upper hinge bracket may spring closed.**
- 4) Replace the upper hinge bracket inner screw in its original position and tighten, then tighten the upper hinge bracket outer screw.

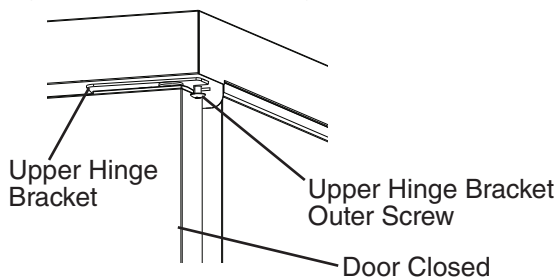

Fig. 7

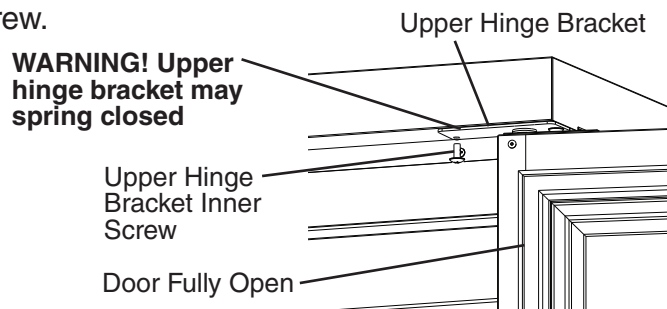

Fig. 8

- 5) Remove the lower hinge bracket. See Fig. 9. Be sure to leave the thrust washer in place.
- 6) Clear the foam from the lower hinge bracket mounting holes prior to securing lower hinge bracket in its new location. Install the lower hinge bracket in its new location. Be sure the lower hinge bracket is pushed all the way in and the thrust washer is in its original position.

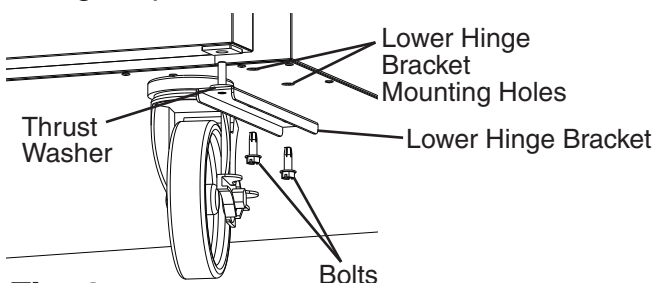

Fig. 9

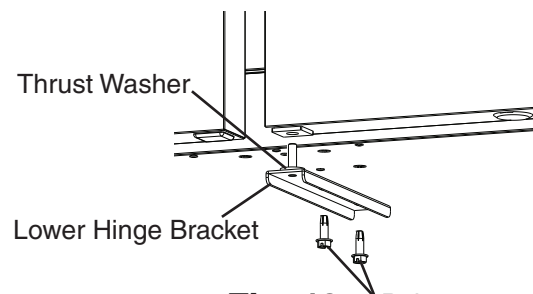

Fig. 10

Upper Hinge Bracket Removal and Spring Cartridge Relocation

- 7) While preventing the upper hinge bracket from rotating, remove the upper hinge bracket from the spring cartridge. See Fig. 11. Note which side of the upper hinge bracket is facing up.
- 8) Remove the filler cap, filler screws, and spring cartridge. See Fig. 12. Leave the thrust washers in place on the spring cartridge. **NOTICE! Spring cartridge may be difficult to remove. Be careful not to damage the finish.**

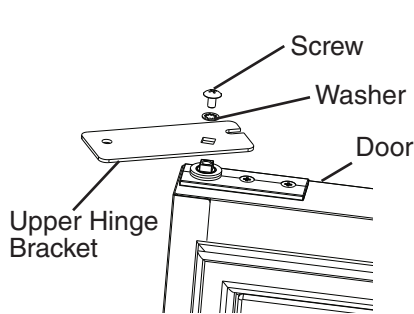

Fig. 11

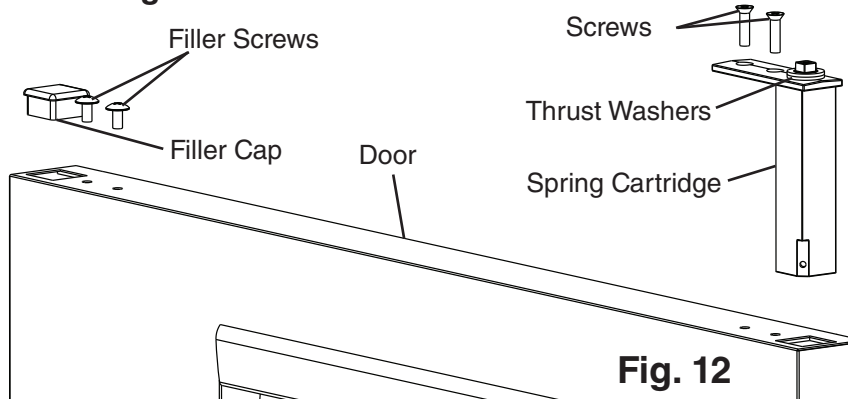

Fig. 12

- 9) Clear foam from the spring cartridge hole to allow for spring cartridge installation. See Fig. 13. Install the spring cartridge in its new location. Reinstall the filler cap and filler screws on the opposite side of the door.

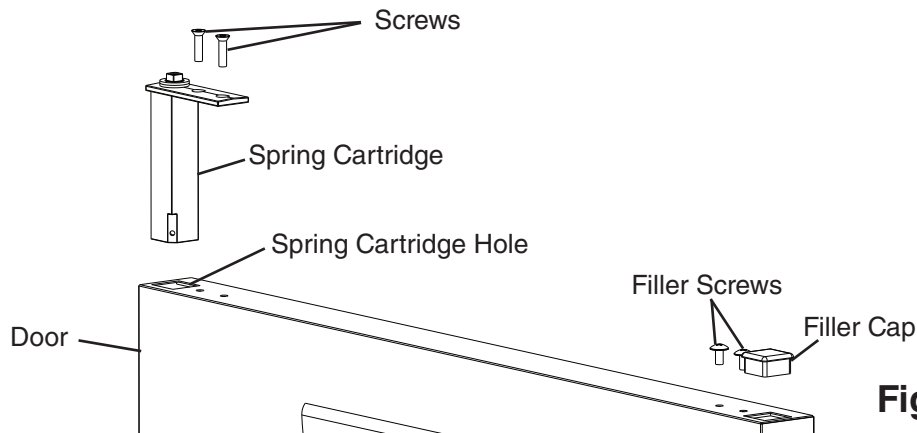

Fig. 13

Lower Door Prep and Upper Hinge Bracket Relocation

- 10) Remove the filler cap and nylon bearing from the bottom of the door. See Fig. 14. Reinstall on the opposite side.
- 11) Make sure the thrust washers are in place on the spring cartridge, then flip the upper hinge bracket over from its original position and install onto the spring cartridge in the door open position. See Fig. 15. The upper hinge bracket should be positioned as shown.

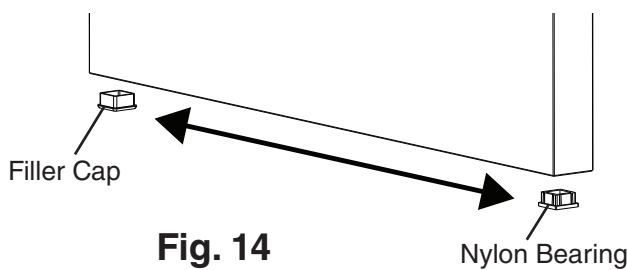

Fig. 14

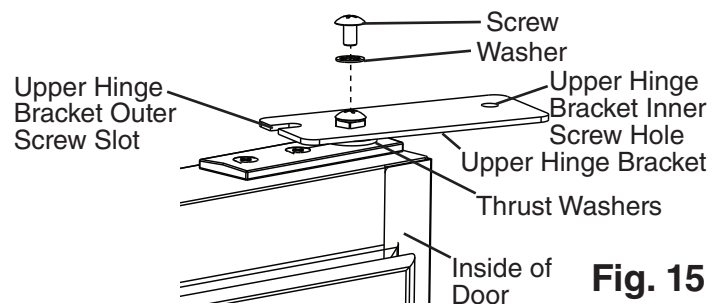

Fig. 15

Door Installation

- 12) Remove the black plastic filler cap located from the hole above where the spring cartridge screw will line up. Note: The black plastic filler cap is not reusable.
- 13) Remove the upper hinge bracket screws from the new location and apply Loctite Threadlocker Blue 242 or 243 to the threads. Next, start the upper hinge bracket outer screw into the appliance. Rotate a few threads into the appliance; do not tighten the screw. See Fig. 16.

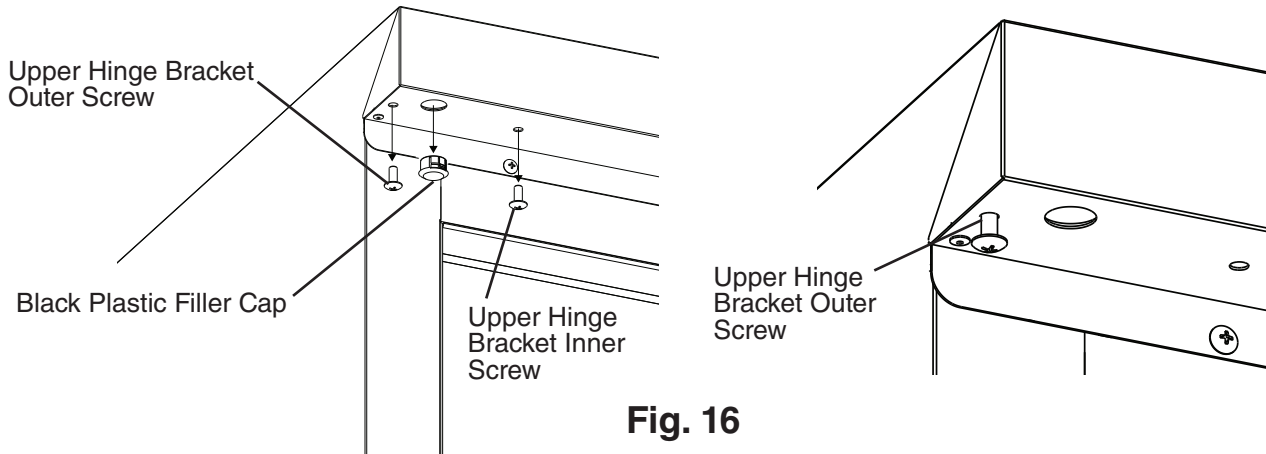

Fig. 16

- 14) Be sure the lower hinge bracket thrust washer is in place, then place the door on the lower hinge bracket in the fully open position. Slide the door upper hinge bracket outer slot onto the upper hinge bracket outer screw. See Fig. 17.
- 15) Install the upper hinge bracket inner screw and tighten.

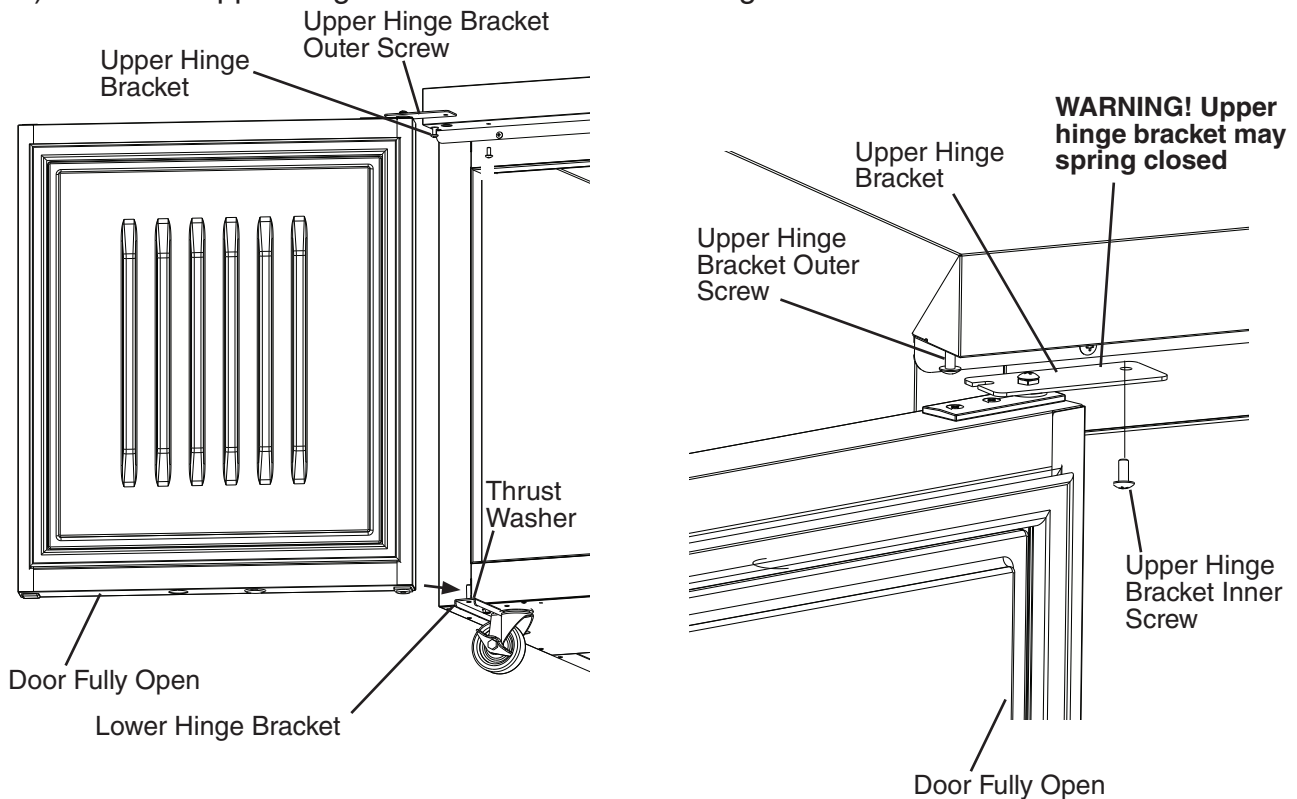

Fig. 17

16) Close the door and tighten the upper hinge bracket outer screw.
See Fig. 18.

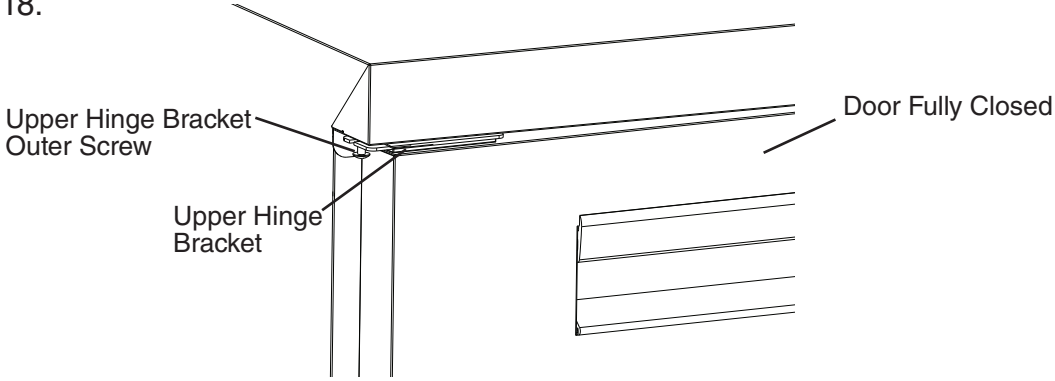

Fig. 18

- 17) Check the door operation to assure it opens and closes properly. Note: Hold door at 45° angle from closed position and release. Door should close on its own. If not, adjust hinge bracket.
- 18) Unlock the casters and move the appliance back into its original position. Lock the casters once in position, then plug the appliance back into the electrical outlet. Allow the appliance to cool down prior to putting product back in.

E. Door/Drawer Reversal

The appliance is provided with a cabinet design which, after being delivered to the installation location, permits changing of the drawer and door locations. To change the drawer and door locations, follow the steps below.

⚠ WARNING

- Wear proper PPE (personal protection equipment) when executing these procedures (safety glasses and gloves).
- Keep fingers away from edge of upper hinge bracket. Spring cartridge can cause the upper hinge bracket to move suddenly with extreme force.

Drawer and Drawer Cartridge Removal

- 1) Remove all items from the appliance. Make sure the appliance is unplugged from the electrical outlet. Move the appliance out for ease of access then lock the casters. See Fig. 19.
- 2) Remove the drawers. Pull the drawer out to its fully extended position. Open the safety clips (one on each side) by sliding them forward. Lift up slightly and remove them from the drawer cartridge. See. "III.A.5. Drawers" for reference. Be sure to note which is the upper drawer and which is the lower drawer.

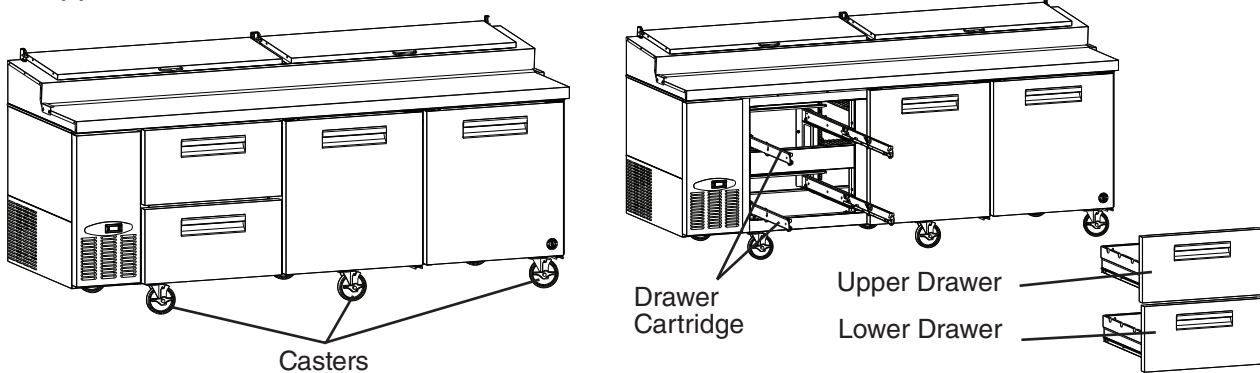

Fig. 19

- 3) Remove the 4 mullion screws, then cut the front mullion silicone loose and remove the mullion. See Fig. 20.

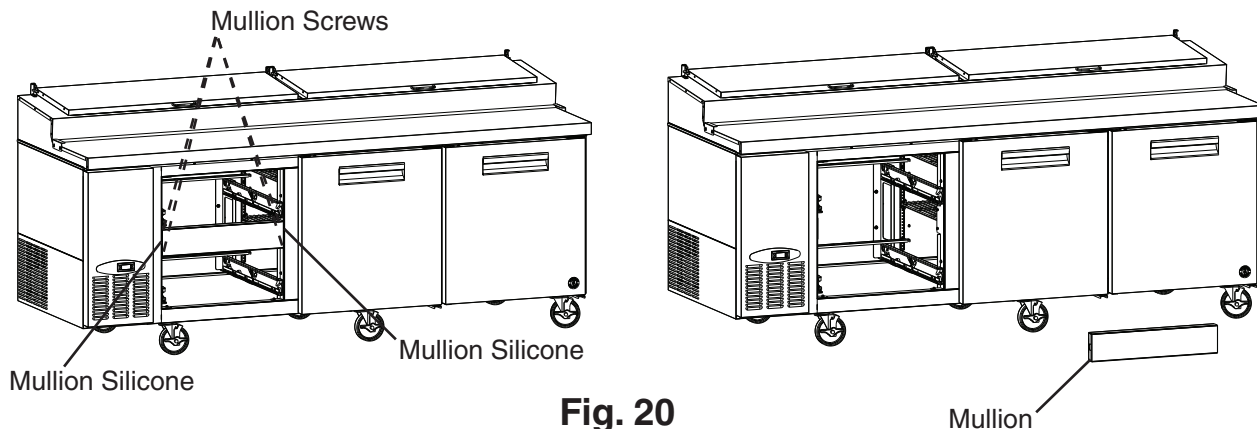

Fig. 20

- 4) Remove the 4 rear screws from the left and right drawer cartridge frames (2 per side). See Fig. 21.
- 5) Remove the 8 front screws from the left and right drawer cartridge frames (4 per side), then remove the cartridge frames from the unit.

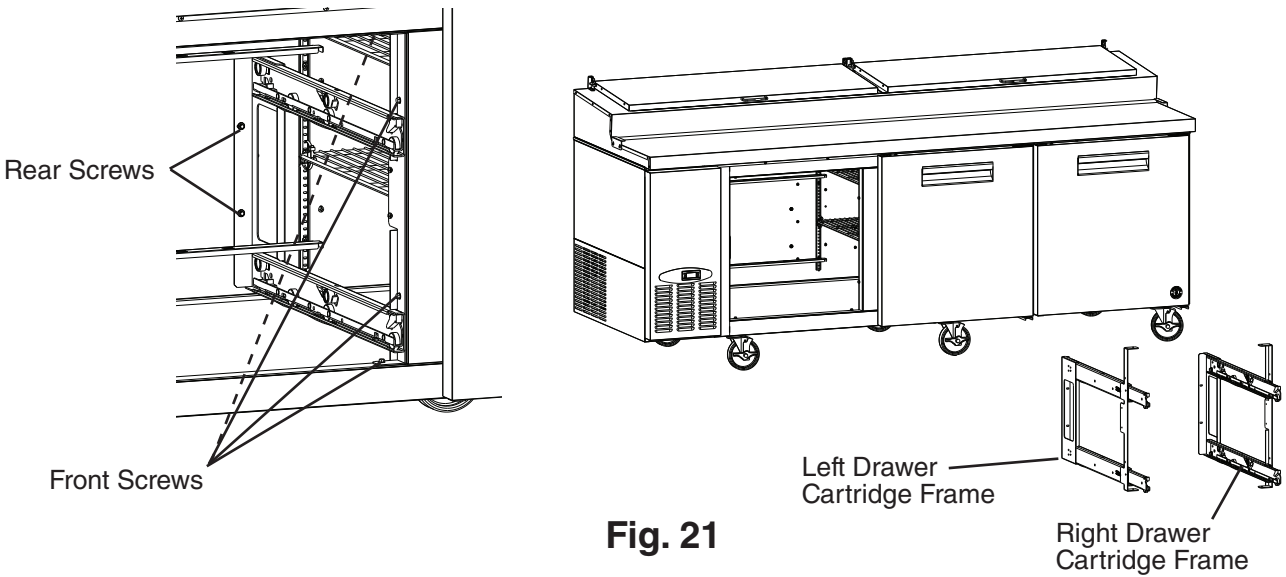

Fig. 21

Pilaster and Filler Screw Relocation

- 6) Remove the 12 pilaster filler screws from the current drawer section. See Fig. 22.

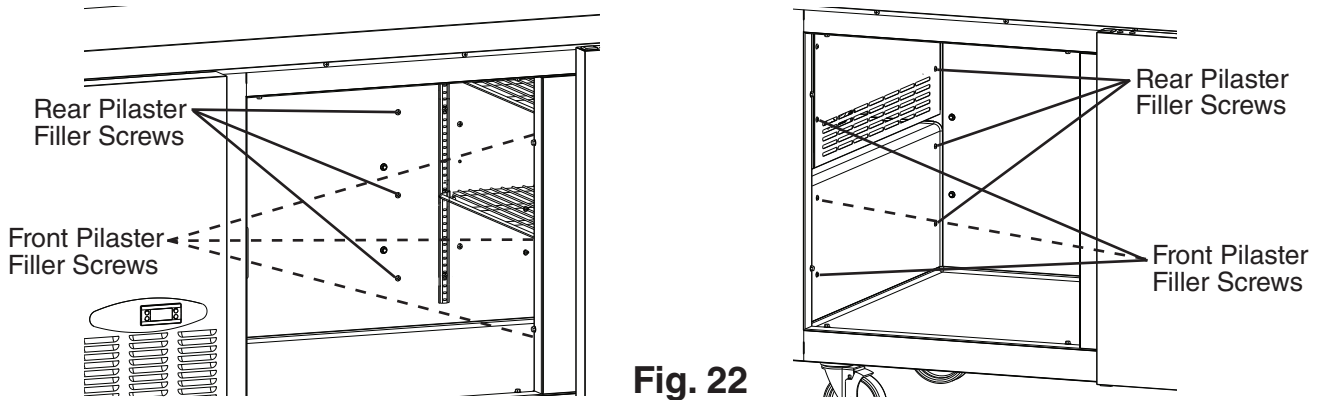

Fig. 22

- 7) Remove the shelves from the door section, then remove the pilasters and place and secure them in the new location (current drawer location). See Fig. 23. Note: Other than in a center location, outer pilasters mount on the side wall not the rear wall.
- 8) Place and secure the pilaster filler screws removed in step 6 into the new drawer location (current door location).

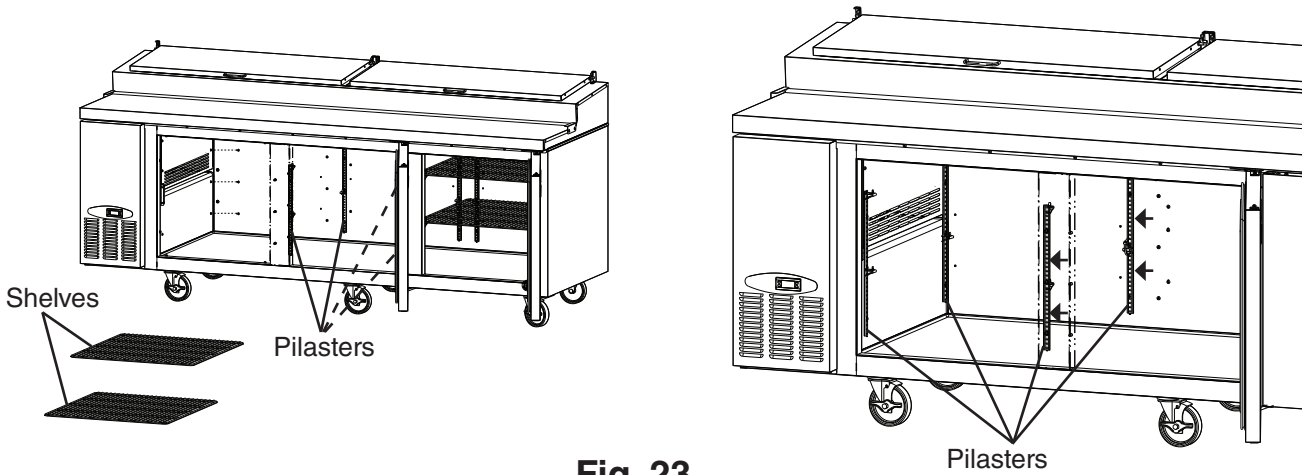

Fig. 23

- 9) Remove the drawer cartridge frame rear filler screws from the new location (current door location). Place the drawer cartridge frame filler screws in the new door location and tighten. Replace the shelves. See Fig. 24.

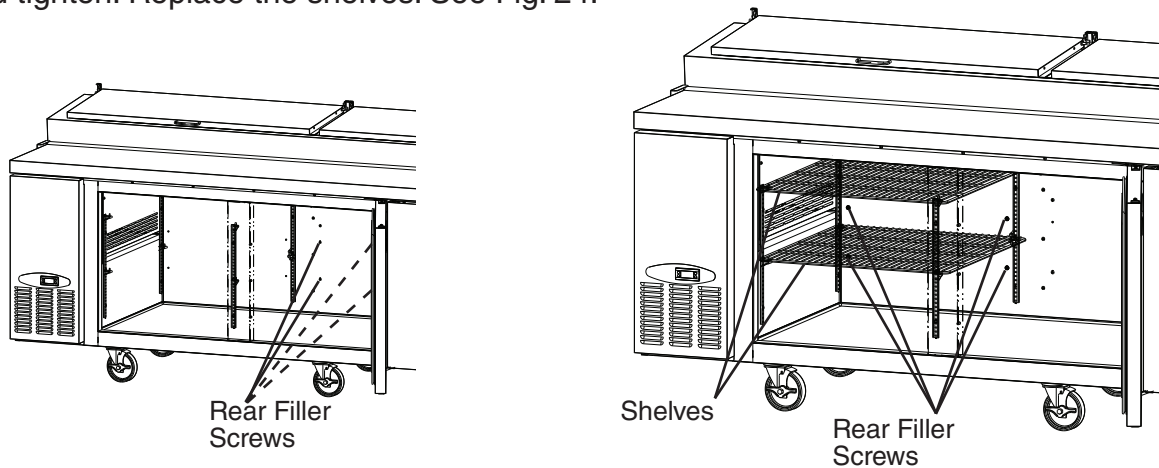

Fig. 24

Door Relocation

- 10) With the door closed, loosen, but do not remove, the upper hinge bracket outer screw. See Fig. 25. Next, open the door to the fully open position and remove the upper hinge bracket inner screw. See Fig. 26.
- 11) Slide the upper hinge bracket out from under the outer screw and remove the door. **WARNING! Keep away from upper hinge bracket. Upper hinge bracket may spring closed.**
- 12) Replace the upper hinge bracket inner screw in its original position and tighten, then tighten the upper hinge bracket outer screw.

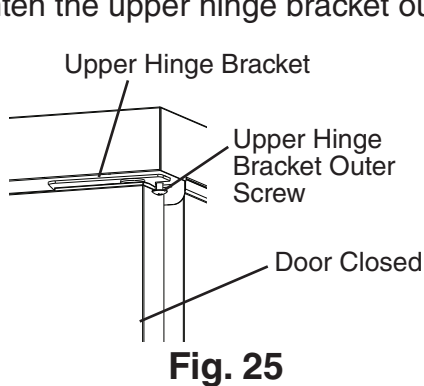

Fig. 25

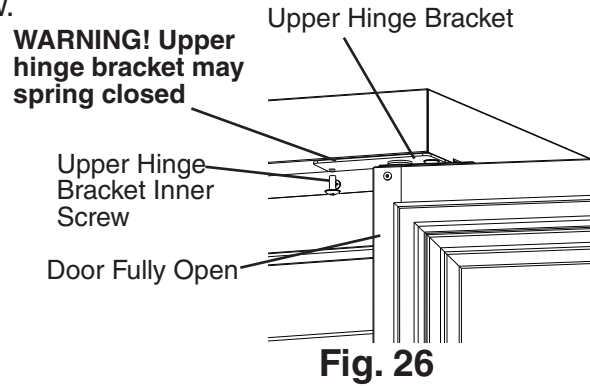

Fig. 26

- 13) Remove the lower hinge bracket. See Fig. 27. Be sure to leave the thrust washer in place.
- 14) Clear the foam from the lower hinge bracket mounting holes prior to securing the lower hinge bracket in its new location. Install the lower hinge bracket in its new location. Be sure the lower hinge bracket is pushed all the way in and the thrust washer is in its original position.

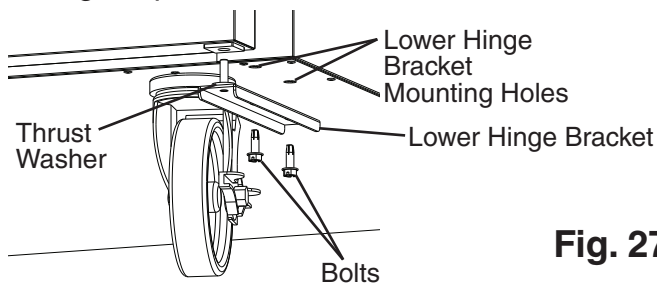
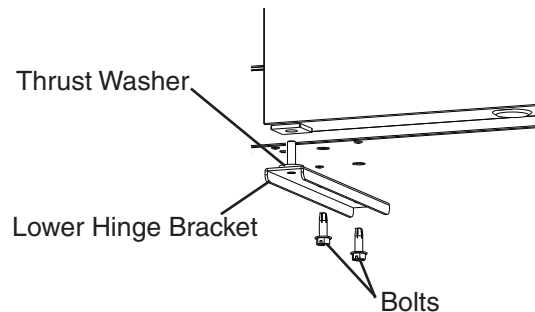

Fig. 27



- 15) Remove the black plastic filler cap located from the hole above where the spring cartridge screw will line up. Note: The black plastic filler cap is not reusable.
- 16) Remove the upper hinge bracket screws from the new location and apply Loctite Threadlocker Blue 242 or 243 to the threads. Next, start the upper hinge bracket outer screw into the appliance. Rotate a few threads into the appliance; do not tighten the screw. See Fig. 28.

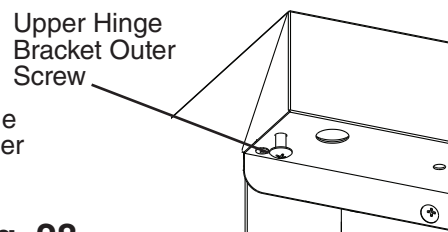
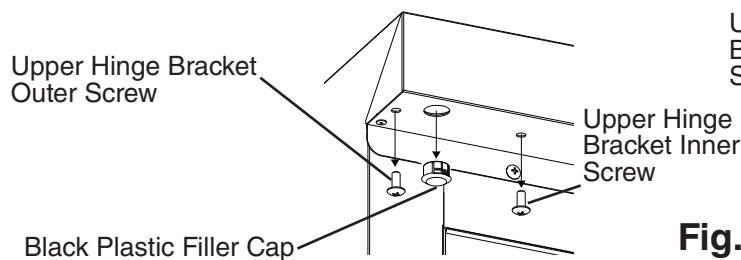

Fig. 28

17) Be sure the lower hinge bracket thrust washer is in place, then place the door on the lower hinge bracket in the fully open position. Slide the door upper hinge bracket outer slot onto the upper hinge bracket outer screw. See Fig. 29.

18) Install the upper hinge bracket inner screw and tighten.

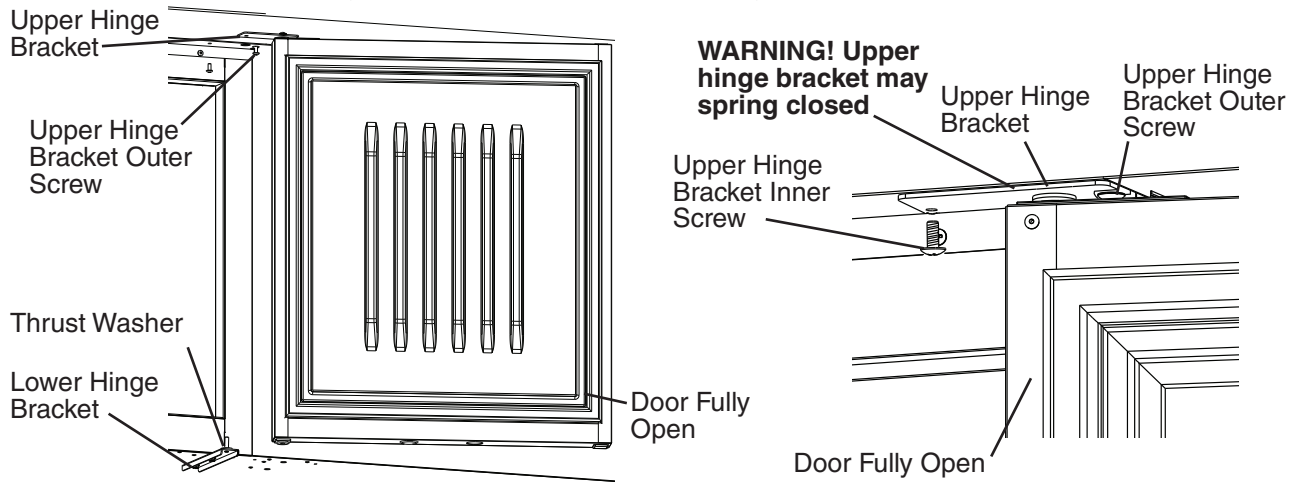

Fig. 29

19) Close the door and tighten the upper hinge bracket outer screw. See Fig. 30.

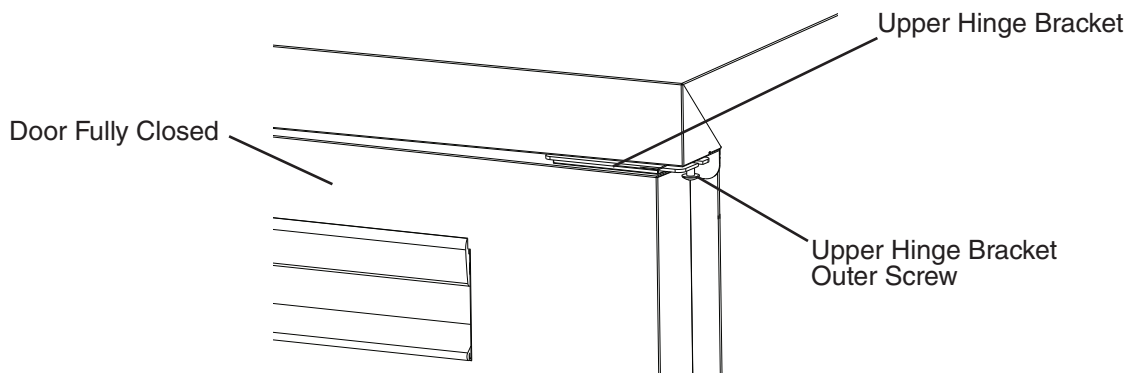
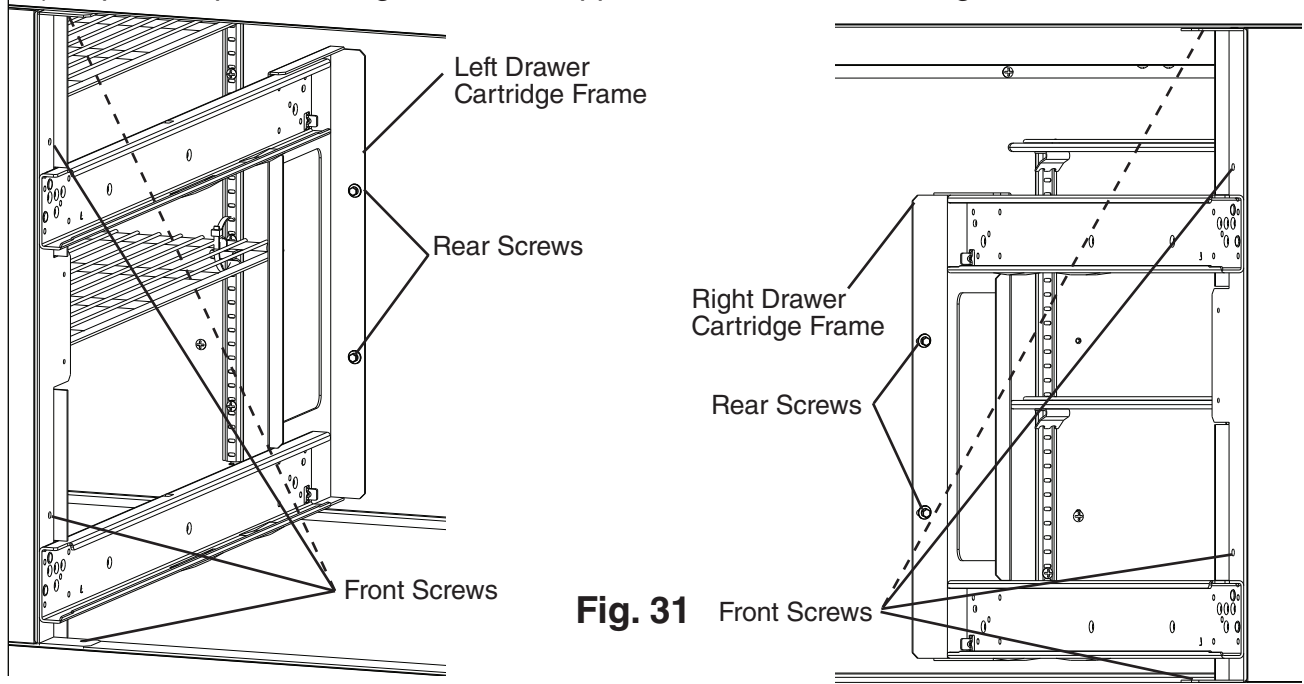

Fig. 30

20) Check the door operation to assure it opens and closes properly. Note: Hold door at 45° angle from closed position and release. Door should close on its own. If not, adjust hinge bracket.

Drawer Relocation

- 21) Place a drawer cartridge frame in place and secure to the rear panel with screws removed in step 4. See Fig. 31.
- 22) Using a 1/8" drill bit, drill pilot holes in all 4 front mounting holes.
- 23) Secure the drawer cartridge to the appliance with the the screws removed in step 5.
- 24) Repeat steps 21 through 23 for the opposite side drawer cartridge frame.



- 25) Place the mullion in its correct position and secure with screws removed in step 3.
- 26) Place a bead of food grade silicone down the 2 outside vertical gaps between the mullion and appliance. See Fig. 32.

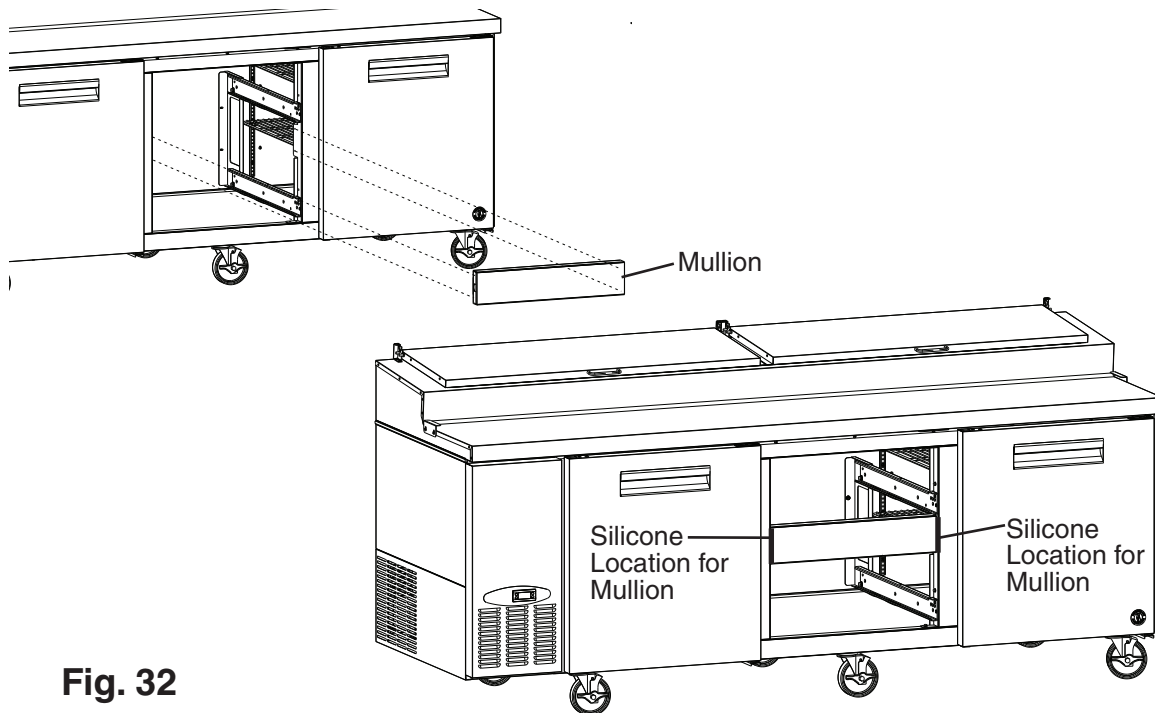

- 27) Place the lower drawer in the lower drawer slides and the upper drawer in the upper drawer slides. See Fig. 33. **WARNING! Be sure to close the safety clips when reinstalling the drawer.**
- 28) Make sure all gaskets are making good contact. Using a flashlight, check that there are no openings around all gaskets.
- 29) Unlock the casters and move the appliance back into its original position. Lock the casters once in position, then plug the appliance back into the electrical outlet. Allow the appliance to cool down prior to putting product back in.

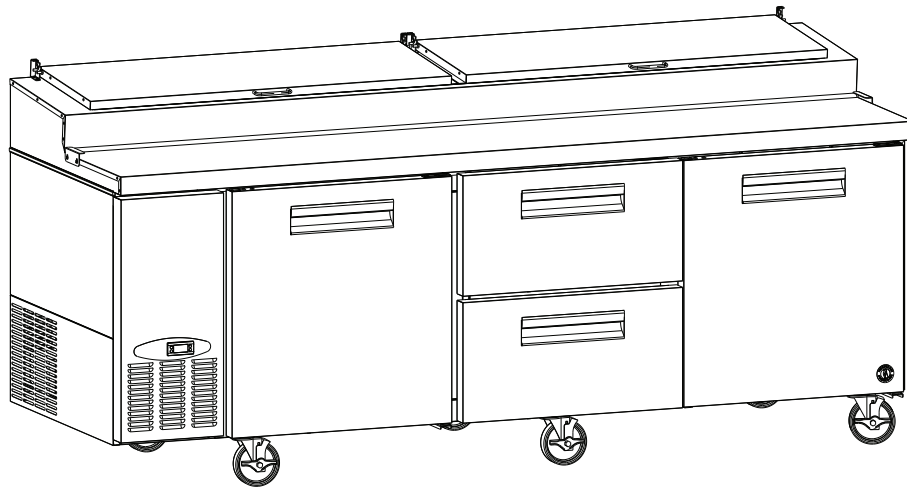



Fig. 33

F. Electrical Connection

WARNING

- Electrical connection must meet national, state, and local electrical code requirements. Failure to meet these code requirements could result in death, electric shock, serious injury, fire, or severe damage to equipment.
 - The appliance requires an independent power supply of proper capacity. See the nameplate for electrical specifications. Failure to use an independent power supply of proper capacity can result in a tripped breaker, blown fuse, damage to existing wiring, or component failure. This could lead to heat generation or fire.
 - **THE APPLIANCE MUST BE GROUNDED.** The appliance is equipped with a NEMA 5-15 three-prong grounding plug  to reduce the risk of potential shock hazards. It must be plugged into a properly grounded, independent 3-prong wall outlet. If the outlet is a 2-prong outlet, it is your personal responsibility to have a qualified electrician replace it with a properly grounded, independent 3-prong wall outlet. Do not remove the ground prong from the power cord and do not use an adapter plug. Failure to follow these instructions may result in death, electric shock, or fire.
 - To reduce the risk of electric shock, do not touch the plug with damp hands.
 - Do not use an extension cord.
 - Do not use an appliance with a damaged power cord. The power cord should not be altered, jerked, bundled, weighed down, pinched, or tangled. Such actions could result in electric shock or fire. To unplug the appliance, be sure to pull the plug, not the cord, and do not jerk the cord.
 - The GREEN ground wire in the factory-installed power cord is connected to the appliance. If it becomes necessary to remove or replace the power cord, be sure to connect the power cord's ground wire.
- Usually an electrical permit and services of a licensed electrician are required.
 - The maximum allowable voltage variation is ± 10 percent of the nameplate rating.

G. Final Checklist

- 1) Is the appliance level?
- 2) Have the casters been properly installed and have the front casters been locked? For CPT46(-D) models, has the anti-tip bracket been properly installed and adjusted?
- 3) Is the appliance in a site where the ambient temperature is constantly within 45°F to 86°F (7°C to 30°C)?
- 4) Have the shipping carton, tape, and packing material been removed from the appliance? Has the protective plastic film been removed from both the exterior panels and the interior door/drawer panel?
- 5) Have the appliance and accessories been checked for shipping damage?
- 6) Is there at least 1" (3 cm) clearance at sides for proper air circulation? Are the factory-installed rear bumpers in place to ensure proper rear clearance? Is there at least 10" (25 cm) clearance above the rail to allow the rail cover to open?
- 7) Have the rail dividers, pans, rail cover, cutting board brackets, and cutting board been properly installed?
- 8) Has the power supply voltage been checked or tested against the nameplate rating? Is the power supply a properly grounded, independent wall outlet? Does the electrical connection meet all national, state, and local code and regulation requirements.
- 9) Have the refrigerant lines been checked to make sure they do not rub or touch other lines or surfaces? Has the condenser fan blade been checked to make sure it turns freely? Is the compressor securely attached?
- 10) Have the shelves been adjusted to the desired height?
- 11) Has the end user been given the instruction manual, and instructed on how to operate the appliance and the importance of the recommended periodic maintenance?
- 12) Has the end user been given the name and telephone number of an authorized service agent?
- 13) Has the warranty card been filled out and forwarded to the factory for warranty registration?

II. Operating Instructions

A. Important Notes About Usage

WARNING

- Only qualified service technicians should install and service the appliance.
- Failure to install, operate, and maintain the appliance in accordance with this manual may adversely affect safety, performance, component life, and warranty coverage.
- To reduce the risk of electric shock, do not touch the plug with damp hands.
- Do not splash, pour, or spray water directly onto or into the appliance. This might cause short circuit, electric shock, corrosion, or failure.
- The appliance is not intended for use by persons (including children) with reduced physical, sensory, or mental capabilities, or lack of experience and knowledge, unless they have been given supervision or instruction concerning use of the appliance by a person responsible for their safety.
- Children should be properly supervised around the appliance.
- Do not climb, stand, or hang on the appliance or doors/drawers or allow children or animals to do so. Do not climb into the appliance or allow children or animals to do so. Death or serious injury could occur or the appliance could be damaged.
- Be careful not to pinch fingers when opening and closing the doors/drawers or rail cover. Be careful when opening and closing the doors/drawers or rail cover when children are in the area.
- Open and close the doors/drawers and rail cover with care. Opening the doors/drawers or rail cover too quickly or forcefully may cause injury or damage to the appliance or surrounding equipment.
- Do not use combustible spray or place volatile or flammable substances in or near the appliance. They might catch fire.
- Keep the area around the appliance clean. Dirt, dust, or insects in the appliance could cause harm to individuals or damage to the equipment.
- Do not throw anything onto the shelves or load any single shelf with more than 120 lb. (54.5 kg) of product. They might fall off and cause injury.
- Do not load any single drawer with more than 150 lb. (68 kg) of product. Depending on the weight of product in the drawers, secure the unit as necessary to prevent it from overturning. Do not open more than one drawer at a time.
- The appliance is designed only for temporary storage of food. Employ sanitary methods. Use for any other purposes (for example, storage of chemicals or medical supplies such as vaccine and serum) could cause deterioration of stored items.
- Do not block air inlets or outlets, otherwise cooling performance may be reduced.
- Do not tightly pack the cabinet. Allow some space between items to ensure good air flow. Also allow space between items and interior surfaces.

⚠ WARNING, continued

- Do not put warm or hot foods in the cabinet. Let them cool first, or they will raise the cabinet temperature and could deteriorate other foods in the cabinet or overload the appliance.
- All foods in the cabinet should be wrapped in plastic film or stored in sealed containers. Otherwise foods may dry up, pass their smells onto other foods, cause frost to develop, result in poor appliance performance, or increase the likelihood of cross-contamination. Certain dressings and food ingredients, if not stored in sealed containers, may accelerate corrosion of the evaporator, resulting in failure.
- Do not store items near air outlets in the cabinet. Otherwise, items may freeze up and crack or break causing a risk of injury or contamination of other food.
- The entire rail must always be covered by rail dividers and pans. Otherwise, the appliance will not cool properly. Use only pans up to 6" (15 cm) deep. Do not use damaged rail dividers or pans.
- Ingredients must be pre-chilled to 37°F (3°C) or less before placing in rail.
- Keep the rail cover closed when not actively preparing food.
- The rail is for keeping ingredients cool while preparing food. If not actively preparing food for a long period such as overnight, seal pans with plastic wrap in addition to closing the rail cover. Depending on conditions, the cabinet temperature setting may need to be adjusted to prevent items from freezing. Alternatively, seal ingredients and store them in a refrigerator or freezer.

NOTICE

- Protect the floor when moving the appliance to prevent damage to the floor.
- Keep ventilation openings, in the appliance enclosure or in the built-in structure, clear of obstruction. The factory-installed rear bumpers must be in place to ensure proper rear clearance. Blockage of airflow could negatively affect performance and damage the appliance.
- Do not allow the appliance to bear any outside weight.
- To prevent deformation or cracks, do not spray insecticide onto the plastic parts or let them come into contact with oil.
- To avoid damage to the gasket, use only the door/drawer handle when opening and closing.
- Do not leave the doors/drawers open.
- To avoid damage to the top seal, do not lift the appliance by the top section or remove the top section.
- Do not place anything on top of the rail cover and do not lift the appliance by the rail cover. The rail cover is not designed to bear any outside weight.
- Do not place anything on the air duct panels beneath the pans in the rail. The air duct panels are not load-bearing.

B. Startup

⚠ WARNING

All parts are factory-adjusted. Improper adjustments may adversely affect safety, performance, component life, and warranty coverage.

Allow the appliance to cool down prior to loading it with food products.

- 1) Wash the pans and cutting board before use.
- 2) Cover the entire rail with rail dividers and pans (up to 6" (15 cm) deep). See "I.C.7. Confirm Rail Dividers and Pans are in Place" for details. Leave the pans empty until the appliance cools down. **WARNING! When the rail cover is open, make sure the rear pins on both sides of the rail cover are securely in the rear slots and the front pins are resting securely in the notches. Otherwise, the rail cover could close suddenly and cause injury.**
- 3) Attach the cutting board. See "I.C.8. Attach the Cutting Board" for details. **WARNING! Make sure the cutting board brackets and cutting board are secure. Otherwise, the cutting board could come off and cause injury.**
- 4) Plug the appliance into the electrical outlet. **WARNING! To reduce the risk of electric shock, do not touch the plug with damp hands.** At startup, there is a slight delay before the compressor starts.
- 5) Allow the appliance to cool down prior to loading it with food products. The entire rail must be covered by rail dividers and pans (up to 6" (15 cm) deep) and the rail cover must be closed. Otherwise, the appliance will not cool properly.

C. Controls and Adjustments

1. Temperature Display

The cabinet temperature is displayed on the control module. See Fig. 34. The display default is °F, but it can be changed to read °C. To change, see "I.C.4. Changing the Temperature Display Scale (°F or °C)."

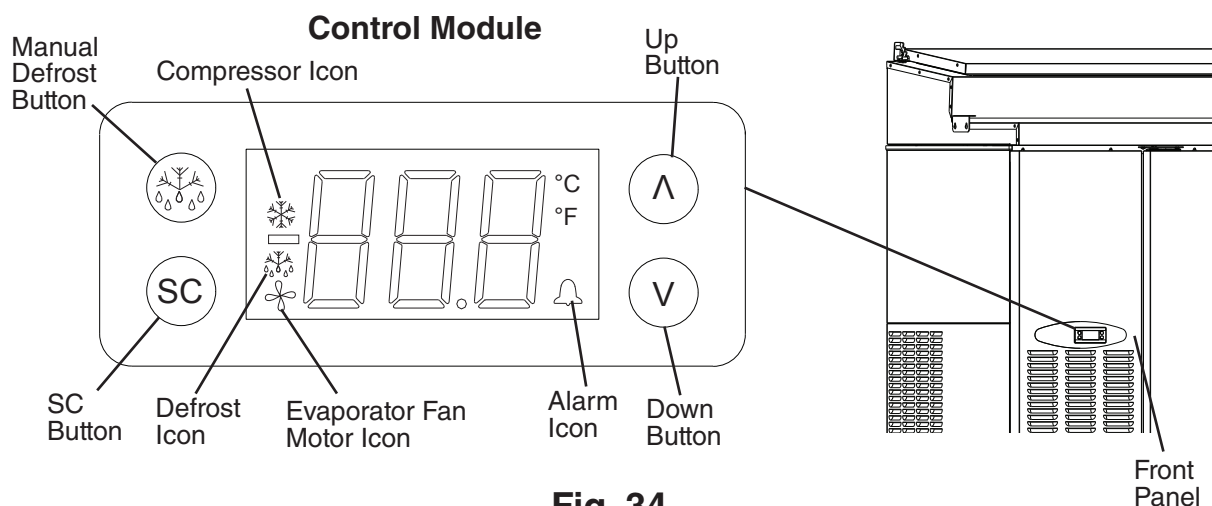

Fig. 34

2. Adjusting the Temperature Setpoint and Rail and Cabinet Cooling

The temperature setpoint and air baffle control are used to adjust the amount of cooling for both the cabinet and the rail.

- 1) To change the temperature setpoint, press and hold the up button briefly and then release. The current temperature setpoint appears. Press the up or down button until the desired value is displayed. After a few seconds, the display returns to the current cabinet temperature and the temperature setpoint is saved.

Temperature Setpoint Range: 14°F to 45°F (-10°C to 7°C)

Factory Default: 32°F (0°C)

Note: The temperature differential for the compressor to turn on and off is $\pm 3^{\circ}\text{F}$ ($\pm 1.7^{\circ}\text{C}$) of the temperature setpoint. For example, for a temperature setpoint of 33°F (1°C), the compressor comes on at 36°F (2.7°C), and the compressor goes off at 30°F (-.7°C).

- 2) To adjust the air flow balance between the rail and cabinet, slightly unscrew the air baffle control knob located inside the cabinet. See Fig. 35. Move the air baffle control clockwise to direct more air flow to the rail or counter-clockwise to direct more air flow to the cabinet. Once the desired position of the air baffle is attained, re-tighten the air baffle control knob to prevent inadvertent movement of the baffle during operation of the appliance.

Air Baffle Control Range: 0 (Colder Rail) to 3 (Colder Cabinet)

Factory Default: 1.5

Note for Extreme Conditions

For extreme conditions where more rail cooling is needed, follow the adjustments in the table below. The adjustments are listed from less extreme to more extreme.

NOTICE! The settings below are for use only when the rail is in active use in extreme conditions. Settings must be returned to factory defaults when the rail is not in active use. Otherwise, performance issues may occur.

Setpoint	Air Baffle Control Setting
23°F (-5°C) to 26°F (-3°C)	2
17°F (-8°C) to 22°F (-6°C)	1
14°F (-10°C) to 16°F (-9°C)	0

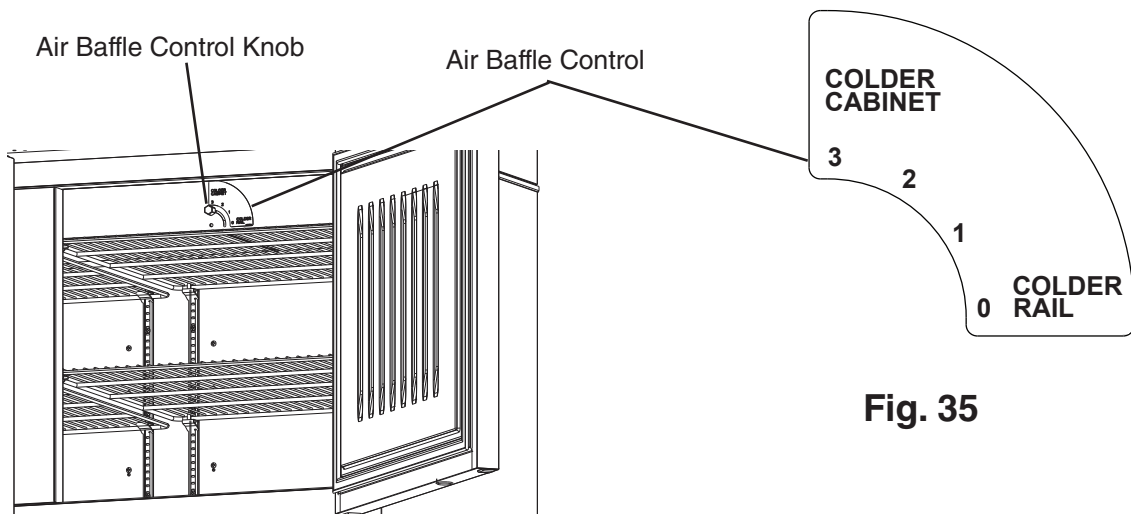

Fig. 35





4. Changing the Temperature Display Scale (°F or °C)

To change the temperature display scale, follow the steps below. The factory default is °F.

- 1) Press and hold both the up and down buttons for 5 seconds. "PAS" appears briefly in the display, then "000" appears.
- 2) Press the up button to change the display to "001".
- 3) Press the SC button. "EHE" appears in the display. Press the up or down button until "diS" is displayed.
- 4) Press the SC button. "CFu" appears in the display. Press the SC button again. The current temperature display scale setting appears. Press the up or down button to change the temperature display scale.
- 5) Press the SC button to save the setting. Wait 1 minute or press the manual defrost button twice to return to the temperature display.

D. Control Module Icons

Control module icons inform you of energized components and if the appliance is in alarm.

Control Module Icons	
Icon	Meaning
	Compressor Compressor running.
	Defrost Appliance is in defrost cycle. See "II.E. Defrost" for details.
	Evaporator Fan Motor Evaporator fan motor is running.
	Alarm Appliance is in alarm. See "II.F. Alarm Safeties" for details.

E. Defrost

1. Automatic Defrost

Defrost is heated and is time-initiated and temperature terminated.

2. Manual Defrost

To initiate a manual defrost, press the manual defrost button.

F. Alarm Safeties

Alarm signals are designed to protect the appliance and food product. These alarms give information or warnings in the event the appliance is operating out of acceptable parameters. Should one of the alarms occur, follow the instructions in the table below to address the alarm. The alarm code and alarm icon flash with audible alarm.

Alarm Signals		
Alarm Code	Problem	Corrective Action/Reset Details
E01	Cabinet Thermistor Malfunction Alarm Cabinet thermistor has failed.	Call a qualified service technician. Beeps for 10 seconds, then silent for 50 seconds. To silence the alarm, press and release the up button. Appliance cycles 5 min. on, 5 min. off.
E02	Defrost Thermistor Malfunction Alarm Defrost thermistor has failed.	Call a qualified service technician. Beeps for 10 seconds, then silent for 50 seconds. To silence the alarm, press and release the up button. Appliance cycles on and off with cabinet thermistor.
Hi	High Temperature Alarm Cabinet temperature has remained above 57°F (13.9°C) for more than 2 hours.	If obvious corrections such as closing doors/drawers and cleaning the air filter and/or condenser do not bring temperature back in range, call a qualified service technician. Beeps for 10 seconds, then silent for 50 seconds. To silence the alarm and clear "Hi" from the display, press and release the up button. The alarm icon stays on. Automatically resets when temperature returns to normal.
Lo	Low Temperature Alarm Cabinet temperature has remained below 26°F (-3.3°C) for more than 2 hours.	If obvious corrections do not bring the temperature back in range, call a qualified service technician. Beeps for 10 seconds, then silent for 50 seconds. To silence the alarm and clear "Lo" from the display, press and release the up button. The alarm icon stays on. Automatically resets when temperature returns to normal.
UHi	High Voltage Alarm (135VAC±5% or more)	Call a qualified service technician.
ULo	Low Voltage Alarm (96VAC±5% or less)	The compressor de-energizes if voltage protection operates. The voltage safeties automatically reset when voltage is corrected.

G. Food Storage

WARNING

- The appliance is designed only for temporary storage of food. Employ sanitary methods. Use for any other purposes (for example, storage of chemicals or medical supplies such as vaccine and serum) could cause deterioration of stored items.
- Do not block air inlets or outlets, otherwise cooling performance may be reduced.
- Do not tightly pack the cabinet. Allow some space between items to ensure good air flow. Also allow space between items and interior surfaces.
- Do not put warm or hot foods in the cabinet. Let them cool first, or they will raise the cabinet temperature and could deteriorate other foods in the cabinet or overload the appliance.
- All foods in the cabinet should be wrapped in plastic film or stored in sealed containers. Otherwise foods may dry up, pass their smells onto other foods, cause frost to develop, result in poor appliance performance, or increase the likelihood of cross-contamination. Certain dressings and food ingredients, if not stored in sealed containers, may accelerate corrosion of the evaporator, resulting in failure.
- Do not store items near air outlets in the cabinet. Otherwise, items may freeze up and crack or break causing a risk of injury or contamination of other food.
- The entire rail must always be covered by rail dividers and pans. Otherwise, the appliance will not cool properly. Use only pans up to 6" (15 cm) deep. Do not use damaged rail dividers or pans.
- Ingredients must be pre-chilled to 37°F (3°C) or less before placing in rail.
- Keep the rail cover closed when not actively preparing food.
- The rail is for keeping ingredients cool while preparing food. If not actively preparing food for a long period such as overnight, seal pans with plastic wrap in addition to closing the rail cover. Depending on conditions, the cabinet temperature setting may need to be adjusted to prevent items from freezing. Alternatively, seal ingredients and store them in a refrigerator or freezer.

H. Safety Devices

1. Compressor External or Internal Protector

If combined temperature/amperage value is above the limit specified by the compressor manufacturer, the compressor protector operates independently to turn off the compressor. The compressor protector de-energizes the compressor until the temperature/amperage value returns to an acceptable level.

2. Short-Cycle Protection

There is a 2-minute minimum off-time and on-time for the compressor.

Note: Time may vary with compressor overload or high-pressure switch activation.

3. High-Pressure Switch

If high-side refrigeration pressure exceeds Hoshizaki specifications, the high-pressure switch activates and de-energizes the compressor circuit until the refrigeration pressure returns to an acceptable level.

I. Cooling Performance

Be sure the appliance is properly installed and located for optimum cooling performance. If cooling performance is not at its optimum level, check the following items:

- Doors/drawers opened too often.
- Doors/drawers left open. Close.
- Cabinet too tightly packed or air inlets/outlets blocked. Allow some space between items to ensure good air flow.
- Warm or hot foods inside. Take them out until they cool down more.
- Ambient temperature too high. Avoid installation near high heat producing equipment or exposure to direct sunlight.
- Temperature setpoint not cold enough. Adjust to a colder setting. See "II.C.2. Adjusting the Temperature Setpoint" for details.
- Appliance in defrost cycle. The cabinet temperature may rise temporarily during the defrost cycle, but this will not affect the food inside.
- Pans and rail dividers not in place. The entire rail must always be covered by rail dividers and pans (up to 6" (15 cm) deep) or the appliance will not cool properly.
- Warm or hot ingredients inside rail. Only load ingredients that have been pre-chilled to 37°F (3°C) or less.
- Rail cover open when not actively preparing food. When not actively preparing food, close the rail cover.

J. Cabinet Condensation

In the event condensation develops on the cabinet exterior, check the following items:

- Doors/drawers left open. Close.
- Ambient humidity too high. In high humidity areas it may be necessary to wipe off the cabinet frame occasionally.

III. Cleaning and Maintenance Instructions

A. Cleaning

⚠ WARNING

- Unplug the appliance before cleaning to prevent electric shock by unexpected entrance of water into the appliance or injury by moving parts. To reduce the risk of electric shock, do not touch the plug with damp hands.
- Before cleaning the appliance, move all foods into another clean refrigerator or freezer.
- Wear proper PPE (personal protection equipment) when executing these procedures (safety glasses and gloves).
- Do not splash, pour, or spray water directly onto or into the appliance. This might cause short circuit, electric shock, corrosion, or failure.
- Carefully follow instructions provided with cleaning and sanitizing products.

NOTICE

- To prevent damage to the plastic surfaces, do not use the following: hot water, thinner, benzine, alcohol, petroleum, soap powder, polishing powder, alkaline cleaner, acid, scouring pad and especially those strong cleaners for use on a ventilating fan or a cooking range.
- To prevent corrosion and damage to stainless steel surfaces, use only products formulated for use on stainless steel appliances. Do not use steel wool, abrasive products, or products containing sodium hypochlorite (chlorine bleach).
- Use a clean cloth for cleaning.

1. Exterior

Wipe the exterior occasionally with a clean, soft cloth. Use a damp cloth containing a neutral cleaner to wipe off oil or dirt buildup. Clean any rust colored spots using a non-abrasive cleanser.

2. Cabinet Interior

Spills should be wiped up promptly to avoid unpleasant odors. The cabinet interior should be cleaned periodically with a mild soap or detergent and warm water.

3. Door/Drawer Gaskets

Door/drawer gaskets should be cleaned regularly with mild soap and warm water to remove dirt and grease.

4. Shelves

Remove and clean regularly.

5. Drawers

Drawers and drawer slides are removable.

- **To remove a drawer:** Remove all items from the drawer. Pull the drawer out to its fully extended position. Open the safety clips (one on each side) by sliding them forward. See Fig. 36. Lift up on the handle slightly, then pull to disengage the drawer. Be sure to support the rear and front of the drawer while removing it. **WARNING! Be sure to close the safety clips when reinstalling the drawer.**
- **To remove a drawer slide (center slide containing rollers):** Open the stop levers (one on each side) by sliding them to the rear. See Fig. 37. Lift up on the drawer slide slightly, then pull to disengage the drawer slide. **WARNING! Be sure to close the stop levers when reinstalling the drawer.** Drawer slides do not require lubrication, but drawer slides should be kept clean and free of food.

Note: Drawer slides are dishwasher safe.

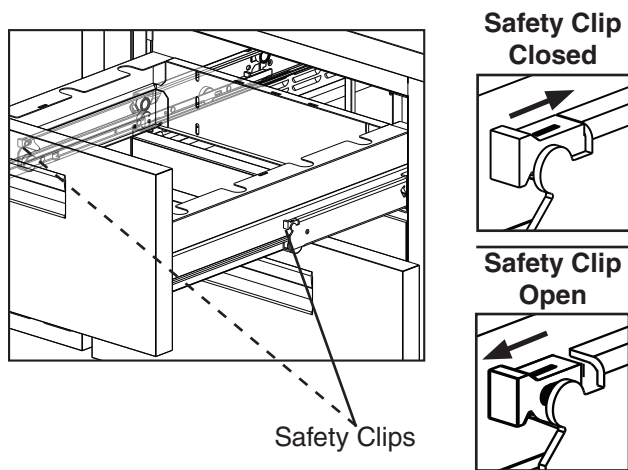

Fig. 36

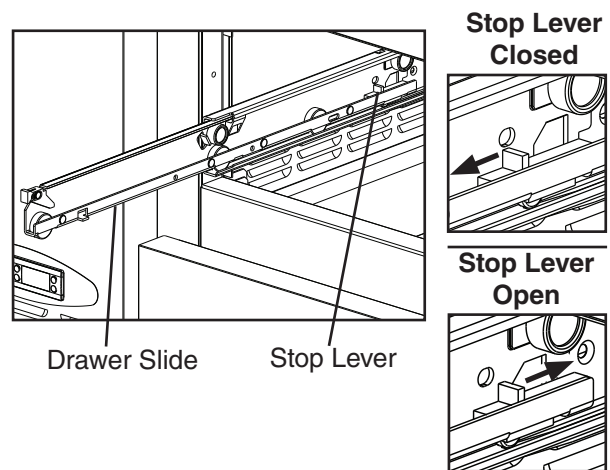

Fig. 37

6. Cutting Board

Remove and clean the cutting board as often as necessary to maintain a clean, sanitary work surface. Also clean the space underneath the cutting board as often as necessary to maintain a clean, sanitary surface. After cleaning, slide the cutting board back under the cutting board brackets. **WARNING! Make sure the cutting board brackets and cutting board are secure. Otherwise, the cutting board could come off and cause injury.**

7. Pans

Wash pans as often as necessary to maintain clean, sanitary conditions.

8. Rail, Rail Dividers, and Rail Cover

Spills and splashes should be wiped up promptly to avoid unpleasant odors. Wipe the rail area, rail dividers, and rail cover occasionally with a clean, damp sponge or cloth containing a neutral cleaner. Clean any rust colored spots using a non-abrasive cleanser. Do not pour or spray water into the rail area.

WARNING!

- **Support the rail cover when cleaning. Otherwise, the rail cover could close suddenly and cause injury.**
- **Metal edges can cause cuts. Use care and wear protective gloves when cleaning.**

9. Rail Air Duct

- 1) Move all foods into another clean refrigerator or freezer.
- 2) Unplug the appliance. **WARNING! To reduce the risk of electric shock, do not touch the plug with damp hands.**
- 3) Remove the pans and dividers from the rail. **WARNING! Support the rail cover when cleaning. Otherwise, the rail cover could close suddenly and cause injury.**
- 4) Air Duct Panel and Rail Area Cleaning: **WARNING! Metal edges can cause cuts. Use care and wear personal protective equipment (gloves and goggles) when cleaning.**
 - a) **Daily:** Wipe the air duct panels and rail area with a mild soap or detergent and warm water. After cleaning, wipe the air duct panels with water.
 - b) **Periodically:** Follow the steps below to remove and clean the air duct panels and rail area. The quantity of air duct panels varies by model. See Fig. 38.
 - (1) Remove the left and right air duct brackets, then remove the upper right air duct panel, upper center air duct panel (if applicable), and upper left air duct panel. Next, remove the lower air duct panel (CPT46(-D) and (CPT67(-D_)), lower right air duct panel, and lower left air duct panel (CPT93(-D_)).
 - (2) Wipe the air duct panels (top and bottom), rail area (sides and top), and surrounding mounting area with mild soap or detergent and warm water. Clean any rust colored spots using a non-abrasive cleanser. After cleaning, wipe the air duct panels with water.
 - (3) Replace the air duct panels in their correct positions starting from the right side. **WARNING! Air duct panels must be replaced in the proper location and orientation. See Fig. 38. Otherwise, cooling performance will be reduced.**
- 7) Place the rail dividers and pans (up to 6" (15 cm) deep) into their correct positions. Leave the pans empty until the appliance cools down.
- 8) Close the rail cover.
- 9) Plug the appliance into the electrical outlet.
- 10) Allow the appliance to cool down prior to loading it with food products. The entire rail must be covered by rail dividers and pans and the rail cover must be closed. Otherwise, the appliance will not cool properly. Leave the pans empty until the appliance cools down.

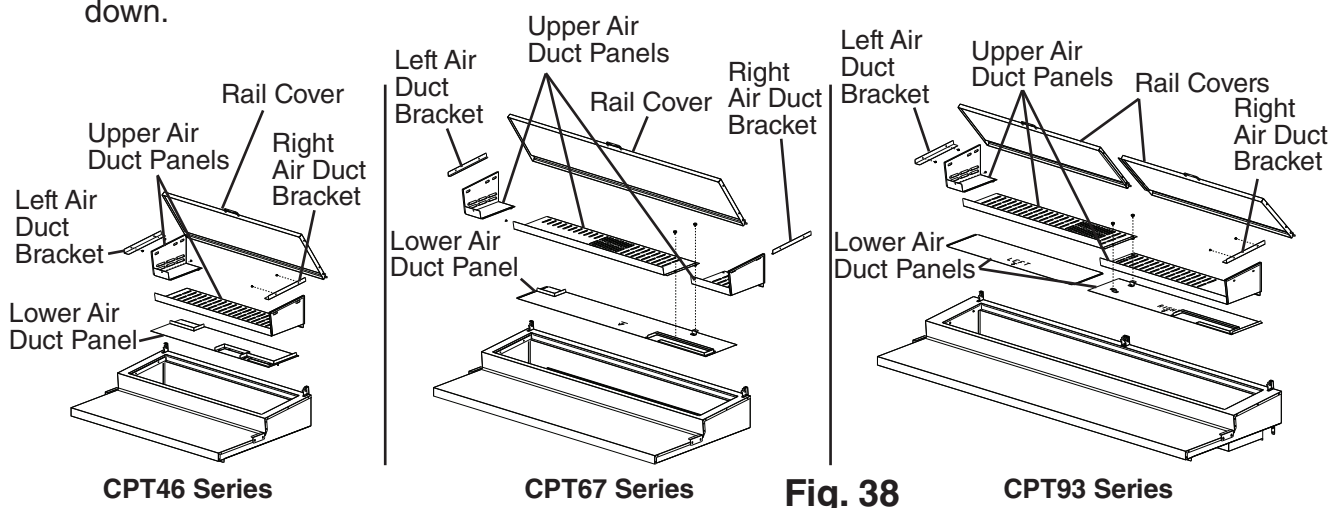

B. Maintenance

⚠ WARNING

- Unplug the appliance before performing maintenance to prevent electric shock or injury by moving parts. To reduce the risk of electric shock, do not touch the plug with damp hands.
- Before performing maintenance, move all foods into another clean refrigerator or freezer.

1. Condenser

Check the condenser once a year, and clean if required by following the steps below. More frequent cleaning may be required depending on location.

- 1) Unplug the appliance from the electrical outlet. **WARNING! To reduce the risk of electric shock, do not touch the plug with damp hands.**
- 2) Remove the screws securing the front panel, then pull and lift the front panel out slightly to remove it. See Fig. 39. **NOTICE! Be careful not to pull out the front panel too far because there are power wires and thermistor wires attached to the control module in the front panel.**
- 3) Without pulling on the wires, set the panel to the side.
- 4) Use a brush attachment on a vacuum cleaner to gently clean the condenser fins. Do not use too much force, otherwise the fins could be damaged. **WARNING! Condenser fins are sharp. Use care when cleaning.**
- 5) Replace the front panel in its correct position. Ensure that the screw is securely in place.
- 6) Plug the appliance back into the electrical outlet.

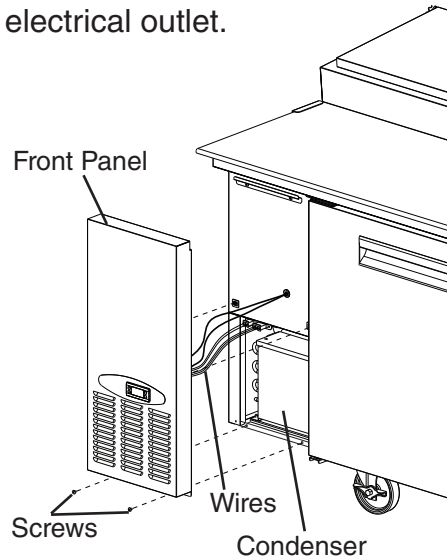

Fig. 39

2. Condensate Drain

Clean the condensate drain as often as necessary to maintain proper flow. Follow the steps below.

- 1) Unplug the appliance from the electrical outlet. **WARNING! To reduce the risk of electric shock, do not touch the plug with damp hands.**
- 2) Remove the screw securing the front panel, then pull and lift the front panel out slightly to remove it. See Fig. 40. **NOTICE! Be careful not to pull out the front panel too far because there are power wires and thermistor wires attached to the control module in the front panel.**
- 3) Without pulling on the wires, set the panel to the side.
- 4) Remove the screws securing the side panel, then slide the panel forward and down slightly and remove.
- 5) Remove the nylon tie, then remove the condensate drain hose and drain elbow. See Fig. 41. **NOTICE! Before removing the condensate drain hose, place a pan underneath the condensate drain pipe to catch any water.**
- 6) Clean the condensate drain hose, drain elbow, and condensate drain pipe with a neutral cleaner and warm water. Rinse thoroughly after cleaning.
- 7) Replace the removed parts in their correct positions. **NOTICE! Be sure the condensate drain hose is secured to the condensate drain pipe with a nylon tie and the condensate elbow is positioned correctly in the condensate pan.**
- 8) Replace the side and front panel in their correct positions. Ensure the screws are securely in place.
- 9) Plug the appliance back into the electrical outlet.

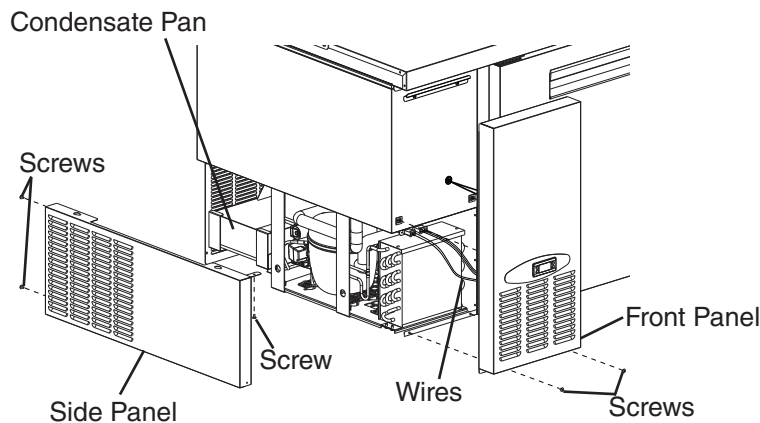

Fig. 40

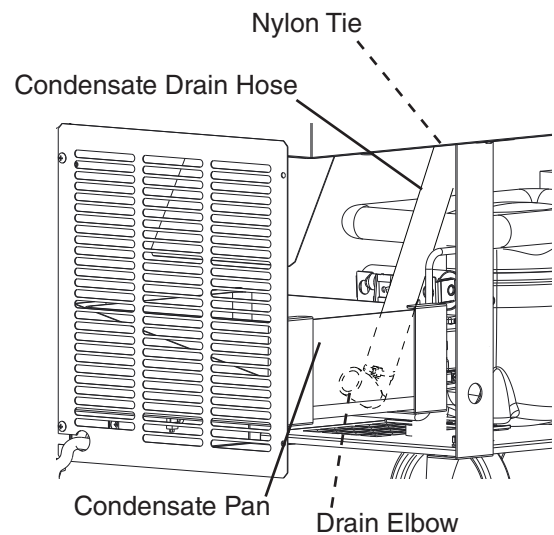

Fig. 41

3. Power Supply Connection

If the plug or power cord is damaged, contact your local Hoshizaki service representative or local Hoshizaki distributor immediately and ask for repairs.

All other maintenance or service on the appliance should be performed in accordance with the Hoshizaki Service Manual by a qualified service technician.

IV. Preparing the Appliance for Periods of Non-Use

When shutting down the appliance for more than one week, follow the instructions below.

⚠ WARNING

When preparing the appliance for long storage, prevent the doors/drawers from closing to reduce the risk of children getting trapped.

<i>NOTICE</i>

When preparing the appliance for long storage, clean the appliance. See "III.A. Cleaning" for details.
--

- 1) Before shutting down the appliance, move all foods into another clean refrigerator or freezer.
- 2) Unplug the appliance. **WARNING! To reduce the risk of electric shock, do not touch the plug with damp hands.**

V. Disposal

⚠ WARNING

When preparing the appliance for disposal, remove the doors/drawers to reduce the risk of children getting trapped. Leave the shelves in place so that children may not easily climb inside.
--

The appliance contains refrigerant and must be disposed of in accordance with applicable national, state, and local codes and regulations. Refrigerant must be recovered by properly certified service personnel.

HOSHIZAKI AMERICA, INC.

618 Hwy. 74 South, Peachtree City, GA 30269 USA (P) 770.487.2331 (F) 770.487.3360 hoshizakiamerica.com 1A4590-012